



ARL-TR-7807 • SEP 2016



# **A Limited Dynamic Investigation of Magnesium Alloy AZ31B in 3 Orientations**

**by Tyrone L Jones and John P Riegel III**

Approved for public release; distribution is unlimited.

## **NOTICES**

### **Disclaimers**

The findings in this report are not to be construed as an official Department of the Army position unless so designated by other authorized documents.

Citation of manufacturer's or trade names does not constitute an official endorsement or approval of the use thereof.

Destroy this report when it is no longer needed. Do not return it to the originator.



# **A Limited Dynamic Investigation of Magnesium Alloy AZ31B in 3 Orientations**

**by Tyrone L Jones**

*Weapons and Materials Research Directorate, ARL*

**John P Riegel III**

*R3 Technology, Inc., Springfield, Virginia*

**REPORT DOCUMENTATION PAGE**

*Form Approved  
OMB No. 0704-0188*

Public reporting burden for this collection of information is estimated to average 1 hour per response, including the time for reviewing instructions, searching existing data sources, gathering and maintaining the data needed, and completing and reviewing the collection information. Send comments regarding this burden estimate or any other aspect of this collection of information, including suggestions for reducing the burden, to Department of Defense, Washington Headquarters Services, Directorate for Information Operations and Reports (0704-0188), 1215 Jefferson Davis Highway, Suite 1204, Arlington, VA 22202-4302. Respondents should be aware that notwithstanding any other provision of law, no person shall be subject to any penalty for failing to comply with a collection of information if it does not display a currently valid OMB control number.

**PLEASE DO NOT RETURN YOUR FORM TO THE ABOVE ADDRESS.**

<b>1. REPORT DATE (DD-MM-YYYY)</b> September 2016		<b>2. REPORT TYPE</b> Technical Report		<b>3. DATES COVERED (From - To)</b> 1 August 2014–31 December 2015	
<b>4. TITLE AND SUBTITLE</b> A Limited Dynamic Investigation of Magnesium Alloy AZ31B in 3 Orientations				<b>5a. CONTRACT NUMBER</b>	
				<b>5b. GRANT NUMBER</b>	
				<b>5c. PROGRAM ELEMENT NUMBER</b>	
<b>6. AUTHOR(S)</b> Tyrone L Jones and John P Riegel III				<b>5d. PROJECT NUMBER</b>	
				<b>5e. TASK NUMBER</b>	
				<b>5f. WORK UNIT NUMBER</b>	
<b>7. PERFORMING ORGANIZATION NAME(S) AND ADDRESS(ES)</b> US Army Research Laboratory ATTN: RDRL-WMP-E Aberdeen Proving Ground, MD 21005-5066				<b>8. PERFORMING ORGANIZATION REPORT NUMBER</b>  ARL-TR-7807	
<b>9. SPONSORING/MONITORING AGENCY NAME(S) AND ADDRESS(ES)</b>				<b>10. SPONSOR/MONITOR'S ACRONYM(S)</b>	
				<b>11. SPONSOR/MONITOR'S REPORT NUMBER(S)</b>	
<b>12. DISTRIBUTION/AVAILABILITY STATEMENT</b> Approved for public release; distribution is unlimited.					
<b>13. SUPPLEMENTARY NOTES</b>					
<b>14. ABSTRACT</b> The work described in this report examines the ballistic characterization of the magnesium alloy AZ31B-H24 in 3 orientations: normal direction, transverse direction, and rolling direction. Semi-infinite impacts from penetrators in each direction are shown. The targets were sectioned and machined using electrical discharge machining in preparation for polishing and etching to determine the extent of plastic flow that can be seen.					
<b>15. SUBJECT TERMS</b> AZ31B, semi-infinite, penetration characterization, WAPEN, effective flow stress (EFS)					
<b>16. SECURITY CLASSIFICATION OF:</b>			<b>17. LIMITATION OF ABSTRACT</b>	<b>18. NUMBER OF PAGES</b>	<b>19a. NAME OF RESPONSIBLE PERSON</b>
<b>a. REPORT</b>	<b>b. ABSTRACT</b>	<b>c. THIS PAGE</b>			Tyrone L Jones
Unclassified	Unclassified	Unclassified	UU	18	<b>19b. TELEPHONE NUMBER (Include area code)</b> 410-278-6223

## **Contents**

---

---

<b>List of Figures</b>	<b>iv</b>
<b>List of Tables</b>	<b>iv</b>
<b>1. Introduction</b>	<b>1</b>
<b>2. Experimental Methodology</b>	<b>1</b>
<b>3. Ballistic Results</b>	<b>4</b>
<b>4. Conclusion and Future Considerations</b>	<b>7</b>
<b>5. References</b>	<b>9</b>
<b>Distribution List</b>	<b>10</b>

## List of Figures

---

---

Fig. 1	Plate fabrication orientation .....	1
Fig. 2	Sketch of 7.62-mm APM2 projectile .....	2
Fig. 3	Setup of the ballistic experiments .....	2
Fig. 4	Ballistic launch view .....	3
Fig. 5	Experimental target fixture with plate oriented in transverse direction for testing .....	3
Fig. 6	Initial penetration trends .....	5
Fig. 7	Normal direction, shot no. 12688, yaw = 1.85° .....	5
Fig. 8	Dimensionless outline of the penetrator core and target crater from shot no. 12688 with 1.85° of yaw .....	6
Fig. 9	Rolling direction, shot no. 12685, yaw 0.93° .....	6
Fig. 10	Shot no. 12685: penetration into normal direction channel showing jacket stripping and core rebound .....	7
Fig. 11	Transverse direction .....	7

## List of Tables

---

---

Table 1	Experimental data .....	4
---------	-------------------------	---

## 1. Introduction

---

Magnesium (Mg) is the lightest structural metal available. Historically, it has not been perceived to have properties suitable for armor applications. However, over the last decade, the US Army Research Laboratory has been examining Mg alloys for ballistic applications.<sup>1</sup> This work has improved the understanding of Mg properties, especially strength and ductility, important factors in the application of Mg in lightweight armors. This report continues the effort, exploring the ballistic performance of Mg as a function of the plate direction. Mg is known for showing significant variation in properties as a function of the loading direction.<sup>2</sup> However, in a search of the literature, we were unable to find work that carefully examined the ballistic performance as a function of plate direction. The directions evaluated are the rolling, also known as longitudinal, direction, normal direction, and transverse direction as shown in Fig. 1.

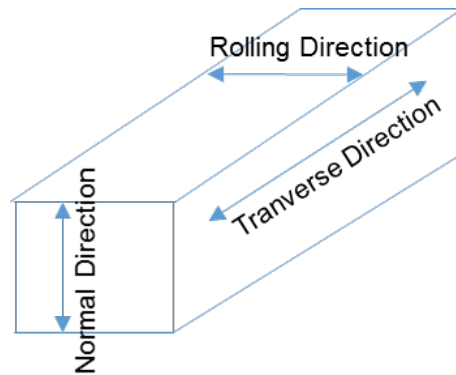

**Fig. 1 Plate fabrication orientation**

The goal of this effort was to develop experimental data comparing performance of AZ31B-H24 in the various orientations. It requires gathering experimental data to determine the variation in penetration as a function of the orientation of the target material relative to the rolling, normal, and transverse directions.

## 2. Experimental Methodology

---

The specific ballistic threat used to test the Mg alloy plate samples was the 7.62-mm APM2 armor-piercing projectile,<sup>3</sup> shown in Fig. 2. The projectile was fired at each face of the Mg AZ31B-H24 targets. The size of the targets were  $609.6 \times 76.2 \times 76.2$  mm thick.

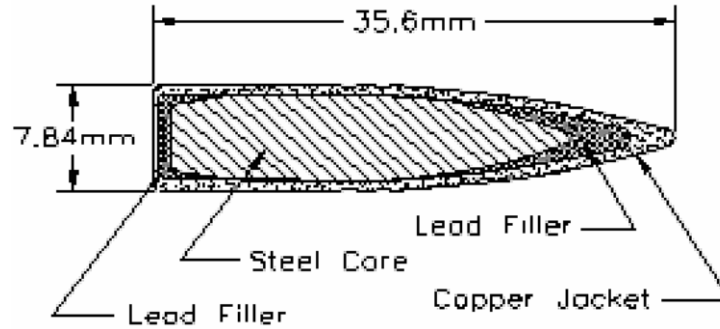

**Fig. 2 Sketch of 7.62-mm APM2 projectile**

Target impact with a total yaw less than one-half degree was desired. The pitch and yaw for each shot were determined by using orthogonal flash X-rays. The total yaw values obtained were typically between  $1^\circ$  and  $2^\circ$ . The potential degradation in penetration as a function of yaw has been previously discussed by Riegel<sup>4</sup> and Yaziv et al.<sup>5</sup> In short, the critical yaw angle is a function of the penetration crater diameter relative to the projectile diameter. For rigid penetration, the ratio of the crater diameter to the projectile diameter goes to 1. That translates to a critical total yaw of  $0^\circ$ . In practice, the amount of degradation depends on the material properties of the target, the shape of the projectile nose, and other factors, making it impossible to assume a simple relationship between penetration obtained with an unyawed projectile and that of a yawed projectile. Figure 3 illustrates the setup of the ballistic experiments.

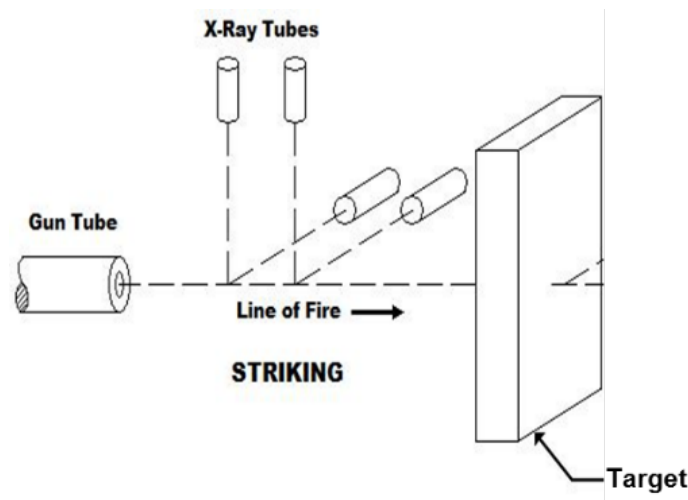

**Fig. 3 Setup of the ballistic experiments**

The distance from the muzzle of the gun barrel for the 7.62-mm APM2 projectile and the target face was 4.52 m (15 ft). The primary velocity measurement tool for the 7.62-mm APM2 projectile was 2 sets of orthogonal 150-kV flash X-rays in front of the target strike face. The spacing between the striking face X-rays was 254 mm

(10 inches) from center to center. The spacing from the center of the closest striking X-ray and the target face was 381 mm (15 inches). The flash X-rays capture orthogonal images of the projectile at 2 times. The images can be corrected to determine the actual distance traveled during the time interval between X-ray flashes. Analysis of the X-ray images includes the projectile orientation relative to the shot line in addition to locating the center of mass of the projectile in each image. These data determine the projectile velocity as well as the projectile pitch and yaw. The ballistic launch view is shown in Fig. 4. The experimental target fixture is shown in Fig. 5.



**Fig. 4 Ballistic launch view**



**Fig. 5 Experimental target fixture with plate oriented in transverse direction for testing**

Three Oehler Model 57 IR screens near the muzzle of the gun barrel were used as a backup system for the projectile velocity measurements. These instruments optically detect the passage of a projectile across a plane that is normal to the shot line. The separation between the light planes, coupled with the time that the light is interrupted, permits the projectile velocity to be computed but does not provide a method for determining pitch or yaw. Since the X-ray system worked for all tests, the data from this backup system were not used.

Semi-infinite penetration occurs when the projectile is fired into a target where the thickness is such that the rear surface is not deformed. The target is sectioned, and the penetration normal to the original impact face is measured. For each shot, the impact velocity, projectile pitch, projectile yaw, and depth of penetration into the AZ31B-H24 targets were recorded.

### 3. Ballistic Results

This first set of data was intended to be at a constant velocity of 457 m/s to capture the rigid mode of the penetrator. In practice, the impact velocities varied from 440 to 473 m/s. The desired limit for total yaw was 0.5°. The measured total yaw values ranged from 0.93 to 1.85°. Table 1 shows the data for this series of shots.

**Table 1 Experimental data**

Shot ID	Direction	Velocity (m/s)	Penetration (mm)	Yaw
12684	RD	444	21.5	1.28
12685	RD	458	26.2	0.93
12686	TD	473	27.7	1.39
12687	TD	440	23.5	1.22
12688	ND	466	24.3	1.85

Notes: RD = rolling direction, TD = transverse direction, and ND = normal direction.

It is interesting to note the difference in slope between the transverse direction shots and the rolling shots, as shown in Fig. 6.

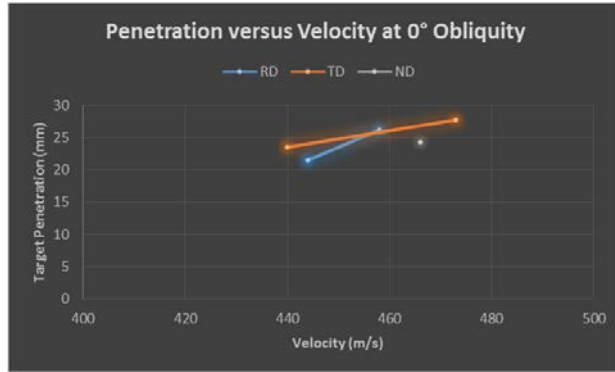

**Fig. 6 Initial penetration trends**

The highest-penetration rolling direction shot impacted at a total yaw of 0.93. The lower penetration rolling direction shot had a yaw of 1.28, and the 2 transverse direction shots had yaws of 1.28 and 1.22. From this data set, there is not sufficient data to draw conclusions regarding the role that yaw plays.

Figure 7 shows the sectioned target for shot no. 12688, fired in the normal direction orientation followed by Fig. 8, which shows an outline of the target crater and projectile core profiles. The outlines more clearly indicate that the crater is not symmetric, with a larger crater in the yaw direction. This is a direct indication that the loading on the projectile is not symmetric. For rigid projectiles impacting relatively soft low-density targets, this can result in shallower penetrations as the projectile deviates from the shot line. Riegel<sup>4</sup> showed how repeatable penetrations can be obtained with yawed impacts that are substantially shorter than penetrations with zero yaw impacts. Unlike eroding projectiles that form a crater in the target, rigid penetration results in a crater that is in contact with the projectile body.



**Fig. 7 Normal direction, shot no. 12688, yaw = 1.85°**

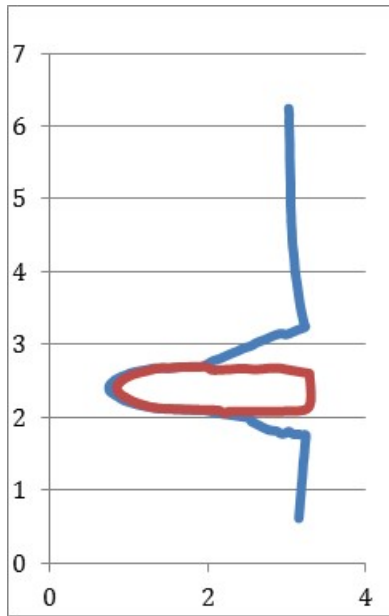

**Fig. 8** Dimensionless outline of the penetrator core and target crater from shot no. 12688 with 1.85° of yaw

The sectioned target for shot no. 12685 is shown in Fig. 9. That shot was fired in the rolling direction and was at the lowest yaw, 0.93°, obtained during the series. Figure 9 illustrates that the jacket is being stripped in a more symmetric manner than seen in shot no. 12688 and shows that the core has rebounded from the point of maximum penetration. The cross section implies that the projectile had a lower yaw, consistent with the yaw measurement. The targets were sectioned along the shot line so the depth of penetration could be more clearly visualized.



**Fig. 9** Rolling direction, shot no. 12685, yaw 0.93°

Figure 10 is an etched optical image of shot no. 12685, indicating the depth of plastic deformation or flow. The region is relatively constant, extending beyond the projectile.

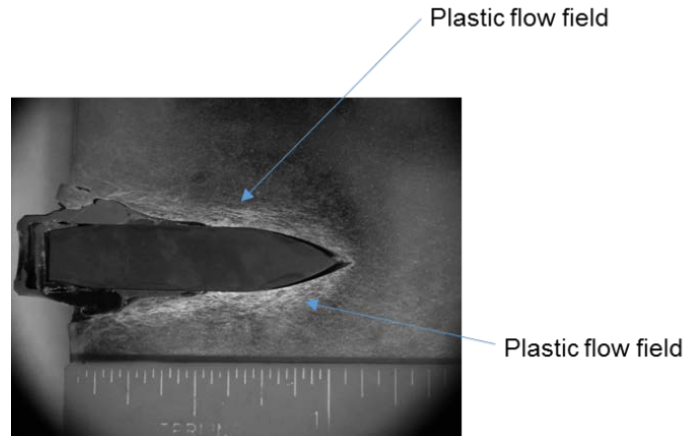

**Fig. 10 Shot no. 12685: penetration into normal direction channel showing jacket stripping and core rebound**

Figure 11 is the view of the penetration produced when the Mg was shot in the transverse direction. The jacket is being stripped in a more symmetric manner than seen in shot no. 12688, and the core has rebounded from the point of maximum penetration.

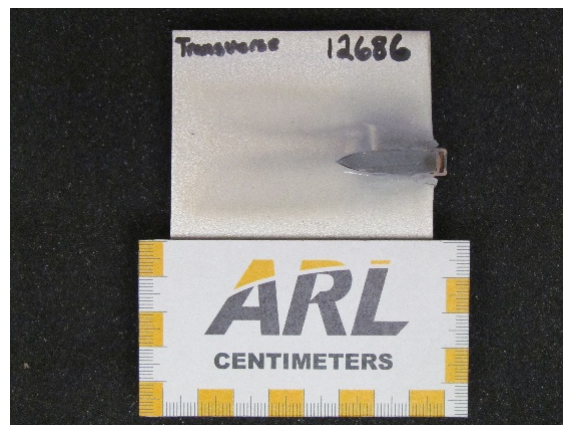

**Fig. 11 Transverse direction**

#### **4. Conclusion and Future Considerations**

---

The experiments conducted in this report are an examination into the effects of grain orientation on ballistic penetration. From our results, the following conclusions can be deduced:

- Yaw reliability was limited in consistently firing a small-arms projectile at  $0.5^\circ$  or less. There were not sufficient data to determine the effect of yaw on the penetration in the semi-infinite blocks.

- The shots fired here were intended to be replicated at the same velocity to establish the repeatability of the shots and determine the difference in penetration as a function of the material orientation. There was slightly more scatter than desired in the impact velocities.

For future considerations, impacts over a wider velocity regime should be considered to capture the spectrum of failure from the projectile into the semi-infinite Mg plate. The higher-velocity regimes will also provide data regarding how yaw affects penetration at those velocities.

Improvements to the experimental methodology or the use of a gas gun may be considered to control the variability of the yaw. Capturing the plastic flow fields in the microstructural analysis at the penetration zone will provide the extent of the material damage and will be the basis of future work.

## 5. References

---

1. Jones TL, DeLorme RD, Burkins MS, Gooch WA. Ballistic evaluation of magnesium alloy AZ31B. Aberdeen Proving Ground (MD): Army Research Laboratory (US); 2007 Apr. Report No.: ARL-TR-4077.
2. Powers B, Dwivedi A, Walter T, Williams C, Meredith C, Ligda J, Schuster B, Casem D. AMX602 – fundamental penetration experiments and basic mechanical characterization. Proceedings of AMX602 Interest Group Workshop; 2014 Oct; Aberdeen Proving Ground, MD.
3. Jones TL. Development of a ballistic specification for magnesium alloy AZ31B. Aberdeen Proving Ground (MD): Army Research Laboratory (US); 2008 Dec. Report No.: ARL-TR-4664.
4. Riegel JP III. The analysis and reporting of V50 – should we do better? Proceedings of the 27th International Symposium on Ballistics; 2013 Apr; Freiburg, Germany.
5. Yaziv D, Rosenberg Z, Riegel JP III. Penetration capability of yawed long rod penetrators. Proceedings of the 12th International Symposium on Ballistics; 29 Oct–1 Nov 1990; San Antonio, TX.

1 (PDF)	DEFENSE TECHNICAL INFORMATION CTR DTIC OCA	1 (PDF)	ARDEC J PARAS
2 (PDF)	DIRECTOR US ARMY RESEARCH LAB RDRL CIO L IMAL HRA MAIL & RECORDS MGMT	1 (PDF)	GALVOTEC S SHOOK
1 (PDF)	GOVT PRINTG OFC A MALHOTRA	1 (PDF)	AMSRD PEO ICE W EVERETT
1 (PDF)	BOEING D HECK	37 (PDF)	DIR USARL RDRL DPT J CRALEY RDRL WML P PEREGINO M ZOLTOSKI RDRL WML H L MAGNESS T EHLERS J NEWILL RDRL WMM M VANLANDINGHAM R DOWDING RDRL WMM C J LABUKAS B PLACZANKIS RDRL WMM D B CHEESEMAN R SQUILLACIOTI R CARTER M KORNECKI RDRL WMM F K DOHERTY J CHINELLA E KLIER S GREENDAHL E HORWATH M TSCHOPP RDRL WMP D LYON RDRL WMP B C HOPPEL RDRL WMP C J LLOYD C WILLIAMS C MEREDITH T BJERKE D CASEM J CLAYTON C MEREDITH R WORTHINGTON RDRL WMP D J RUNYEON D PETTY
1 (PDF)	OHIO STATE UNIV A LUO		
1 (PDF)	R3 TECH J RIEGEL		
3 (PDF)	TABER EXTRUSIONS J SODERA D MOORE A ANNIS		
1 (PDF)	NEW MEXICO INST OF MINING AND TECH J KIMBERLY		
1 (PDF)	SOUTHWEST RSRCH INST K DANNEMANN		
1 (PDF)	EPSON I OTSUKA		
1 (PDF)	OSAKA UNIV K KONDOH		
1 (PDF)	NATIONAL MTRL LP M TAKAHASHI		
2 (PDF)	PACIFIC SOWA H NAKASAWA O YOSHINORI		
1 (PDF)	EPSON ATMIX R NUMASAWA		
1 (PDF)	AEROPROBE N HARDWICK		
1 (PDF)	ORNL W PETER		

RDRL WMP E  
M BURKINS  
T JONES  
P SWOBODA  
RDRL WMP F  
N GNIAZDOWSKI  
RDRL WMS  
H MAUPIN

INTENTIONALLY LEFT BLANK.