



AFRL-RQ-WP-TM-2016-0150

**SLOTTED WAVEGUIDE ANTENNA STIFFENED
STRUCTURES (SWASS) DEVELOPMENT FOR
COMMERCIAL OFF-THE-SHELF (COTS) RADAR
(BRIEFING CHARTS)**

D. Zeppettella

**Structures Technology Branch
Aerospace Vehicles Division**

Steve Bucca and Thomas Gage

BerrieHill Research Corporation

OCTOBER 2016

**DISTRIBUTION STATEMENT A: Approved for public release.
Distribution is unlimited.**

See additional restrictions described on inside pages

**AIR FORCE RESEARCH LABORATORY
AEROSPACE SYSTEMS DIRECTORATE
WRIGHT-PATTERSON AIR FORCE BASE, OH 45433-7541
AIR FORCE MATERIEL COMMAND
UNITED STATES AIR FORCE**

NOTICE AND SIGNATURE PAGE

Using Government drawings, specifications, or other data included in this document for any purpose other than Government procurement does not in any way obligate the U.S. Government. The fact that the Government formulated or supplied the drawings, specifications, or other data does not license the holder or any other person or corporation; or convey any rights or permission to manufacture, use, or sell any patented invention that may relate to them.

This report was cleared for public release by the USAF 88th Air Base Wing (88 ABW) Public Affairs Office (PAO) and is available to the general public, including foreign nationals.

Copies may be obtained from the Defense Technical Information Center (DTIC)
(<http://www.dtic.mil>).

AFRL-RQ-WP-TM-2016-0150 HAS BEEN REVIEWED AND IS APPROVED FOR PUBLICATION IN ACCORDANCE WITH ASSIGNED DISTRIBUTION STATEMENT.

**//Signature//*

DAVID L. ZEPPEITELLA
Program Manager
Structures Technology Branch
Aerospace Vehicles Division

//Signature//

MICHAEL R. WIPPERMAN, Chief
Structures Technology Branch
Aerospace Vehicles Division
Aerospace Systems Directorate

//Signature//

TODD A. ENGELMAN
Senior Aerospace Engineer
Aerospace Vehicles Division
Aerospace Systems Directorate

This report is published in the interest of scientific and technical information exchange and its publication does not constitute the Government's approval or disapproval of its ideas or findings.

*Disseminated copies will show “//Signature//” stamped or typed above the signature blocks.

REPORT DOCUMENTATION PAGE				<i>Form Approved</i> OMB No. 0704-0188	
<p>The public reporting burden for this collection of information is estimated to average 1 hour per response, including the time for reviewing instructions, searching existing data sources, gathering and maintaining the data needed, and completing and reviewing the collection of information. Send comments regarding this burden estimate or any other aspect of this collection of information, including suggestions for reducing this burden, to Department of Defense, Washington Headquarters Services, Directorate for Information Operations and Reports (0704-0188), 1215 Jefferson Davis Highway, Suite 1204, Arlington, VA 22202-4302. Respondents should be aware that notwithstanding any other provision of law, no person shall be subject to any penalty for failing to comply with a collection of information if it does not display a currently valid OMB control number. PLEASE DO NOT RETURN YOUR FORM TO THE ABOVE ADDRESS.</p>					
1. REPORT DATE (DD-MM-YY) October 2016		2. REPORT TYPE Briefing Charts		3. DATES COVERED (From - To) 01 October 2014 – 01 October 2016	
4. TITLE AND SUBTITLE SLOTTED WAVEGUIDE ANTENNA STIFFENED STRUCTURES (SWASS) DEVELOPMENT FOR COMMERCIAL OFF-THE-SHELF (COTS) RADAR (BRIEFING CHARTS)				5a. CONTRACT NUMBER In-house	
				5b. GRANT NUMBER	
				5c. PROGRAM ELEMENT NUMBER 63211F	
6. AUTHOR(S) D. Zeppettella (AFRL/RQVS) Steve Bucca and Thomas Gage (BerrieHill Research Corporation)				5d. PROJECT NUMBER 4920	
				5e. TASK NUMBER	
				5f. WORK UNIT NUMBER Q06A	
7. PERFORMING ORGANIZATION NAME(S) AND ADDRESS(ES) Structures Technology Branch (AFRL/RQVS) Aerospace Vehicles Division Air Force Research Laboratory, Aerospace Systems Directorate Wright-Patterson Air Force Base, OH 45433-7541 Air Force Materiel Command, United States Air Force				BerrieHill Research Corporation 7735 Paragon Road Dayton, OH 45459	
9. SPONSORING/MONITORING AGENCY NAME(S) AND ADDRESS(ES) Air Force Research Laboratory Aerospace Systems Directorate Wright-Patterson Air Force Base, OH 45433-7541 Air Force Materiel Command United States Air Force				8. PERFORMING ORGANIZATION REPORT NUMBER AFRL-RQ-WP-TM-2016-0150	
				10. SPONSORING/MONITORING AGENCY ACRONYM(S) AFRL/RQVS	
11. SPONSORING/MONITORING AGENCY REPORT NUMBER(S) AFRL-RQ-WP-TM-2016-0150				12. DISTRIBUTION/AVAILABILITY STATEMENT DISTRIBUTION STATEMENT A: Approved for public release. Distribution is unlimited.	
				13. SUPPLEMENTARY NOTES PA Case Number: 88ABW-2016-0896; Clearance Date: 07 March 2016. The briefing was presented in March 2016. The U.S. Government is joint author of this work and has the right to use, modify, reproduce, release, perform, display, or disclose the work.	
14. ABSTRACT This slide show describes SWASS development.					
15. SUBJECT TERMS SWASS					
16. SECURITY CLASSIFICATION OF:			17. LIMITATION OF ABSTRACT: SAR	18. NUMBER OF PAGES 19	19a. NAME OF RESPONSIBLE PERSON (Monitor) David L. Zeppettella 19b. TELEPHONE NUMBER (Include Area Code) N/A
a. REPORT Unclassified	b. ABSTRACT Unclassified	c. THIS PAGE Unclassified			



Integrity ★ Service ★ Excellence

RQVS SWASS Development for COTS Radar

7 March 2016

**David Zeppettella
Electronics Engineer
AFRL/RQVS**



SWASS for ImSAR



- NanoSAR : 3 lb., 30 W
- Applications: SAR, FOPEN, MTI
- Frequencies: UHF, L, X, Ku
- Pod mount options: 7-19 lbs

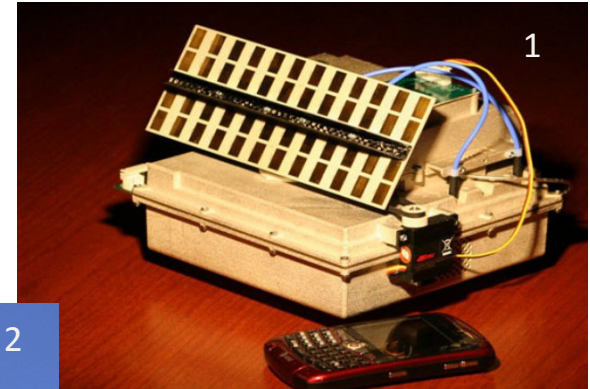

1

ImSAR Pods ₃



2



4

NanoSAR on Scan Eagle

- We have focused on X band SAR and MTI

1. <http://www.uasvision.com/2012/06/15/imsar-gets-24m-nano-sar-contract-for-uas-from-us-army/>
2. http://www.barnardmicrosystems.com/UAV/features/synthetic_aperture_radar.html
3. <http://www.imsar.com/pages/products.php?name=nanosar>
4. <http://www.defenseindustrydaily.com/Us-Army-Wants-a-Small-Radar-for-Small-UAVs-07408/>

Fundamental CLAS/SWASS Concept

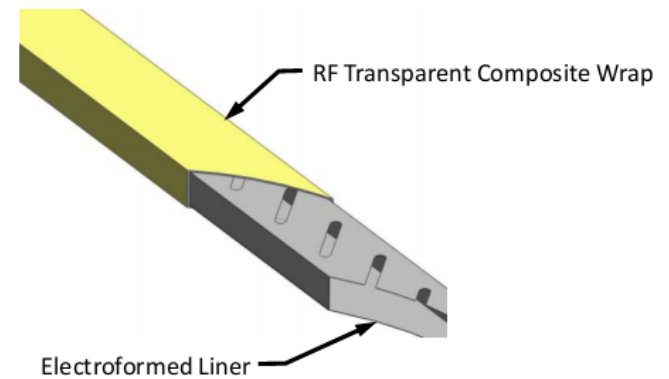
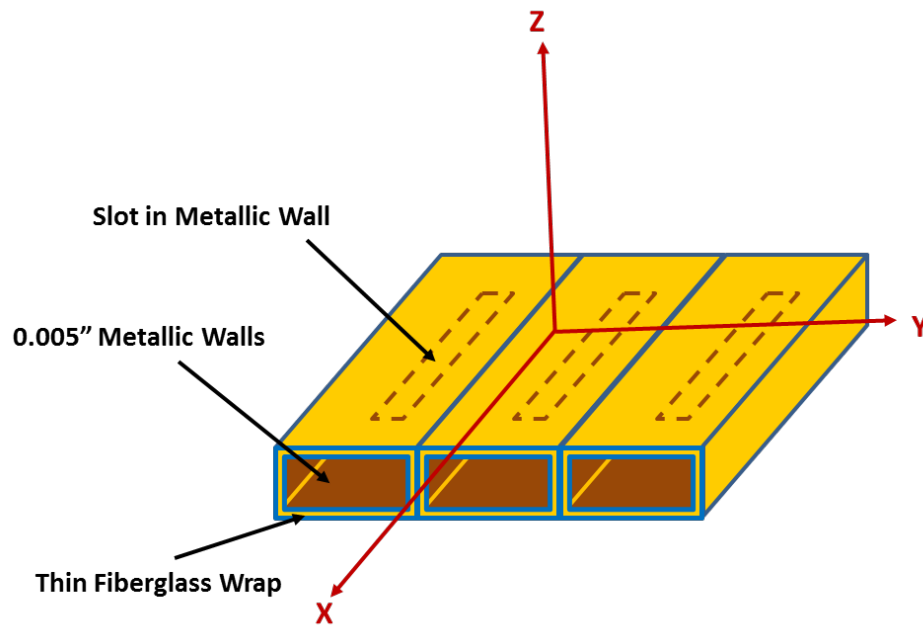

Electroformed Composite Wrapped Waveguide

Note: This is applicable for Astroquartz and Glass Fibers

- **Slotted Waveguide Antenna**
- **Lightweight**
- **Structural / Load Bearing**
- **Conformal with airframe body**

Potential CLAS/SWASS Airborne Implementations

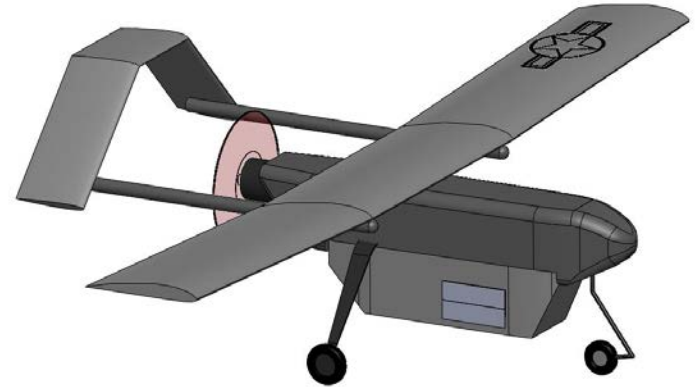
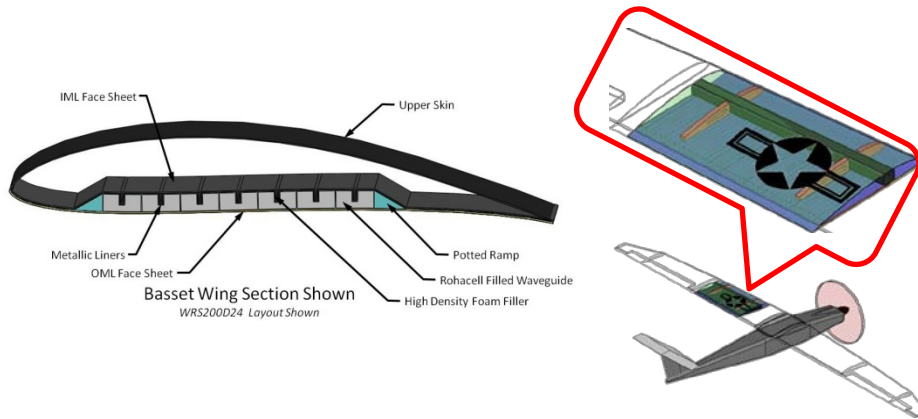

Body / Fuselage Implementation

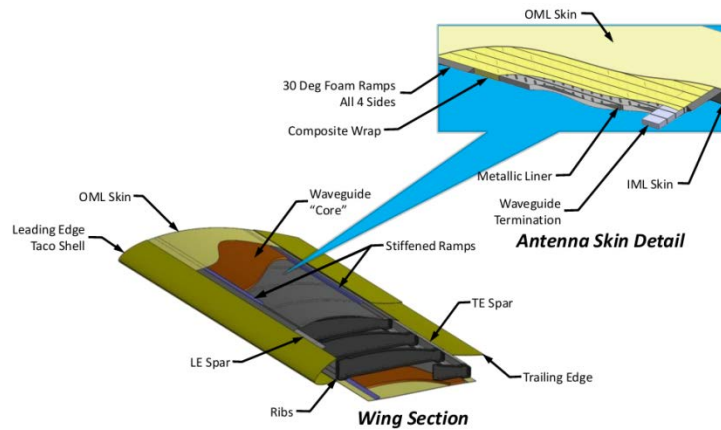

Wing Implementation

Coax Center-Fed Slotted Waveguide Antenna

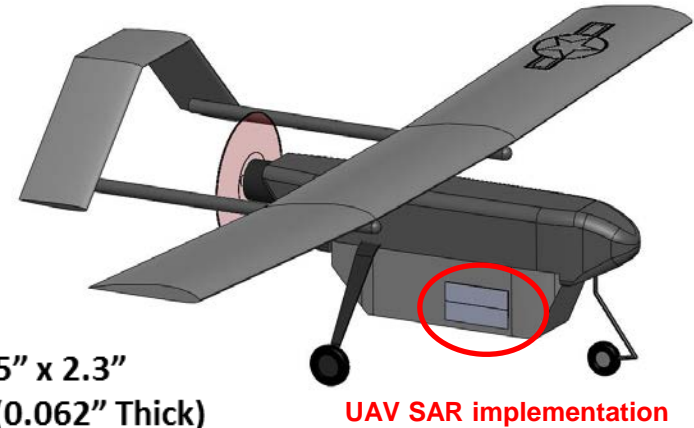
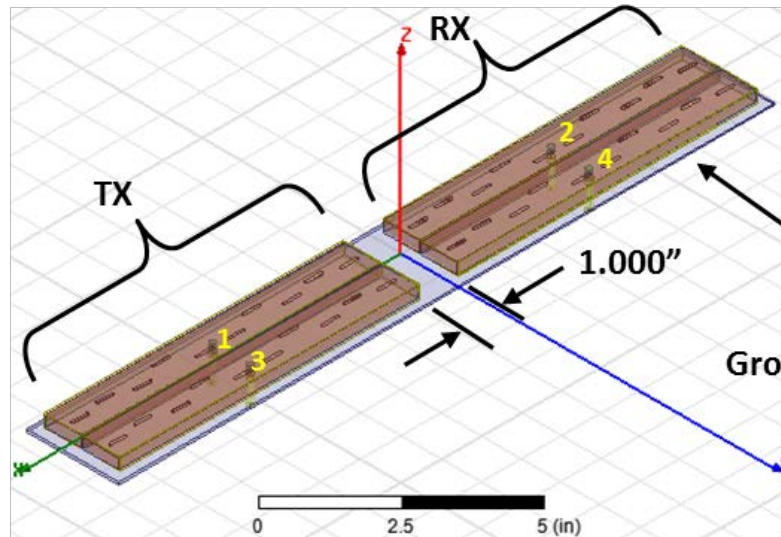

Potential Airborne Applications

- Radar (GMTI, SAR, MTI, FOPEN)

Advantages

- Low to moderate loss
- Little touch labor
- Decent control of side lobes
- Very low X-Pol
- Can be adapted for 1-D scanning
- Moderate to high power capability
- Ability to scale to large apertures

Disadvantages

- Narrow banded (5% to 10%)
- Lack of 2-D scanning capability
- Lossy combiner network (unless manufactured with waveguide technology)

BRC NanoSAR Demo

2 Sock, Epoxy Loaded Slots (190 probes, additional cleaning, internal sanding)

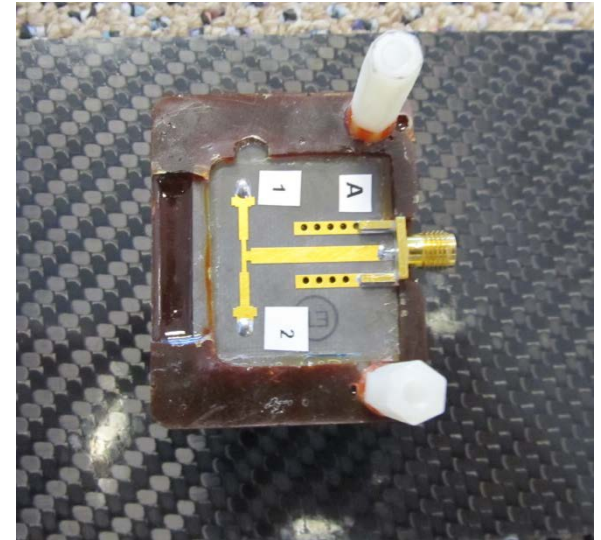

BRC NanoSAR Demo

2 Sock, Epoxy Loaded Slots (190 probes, additional cleaning, internal sanding)

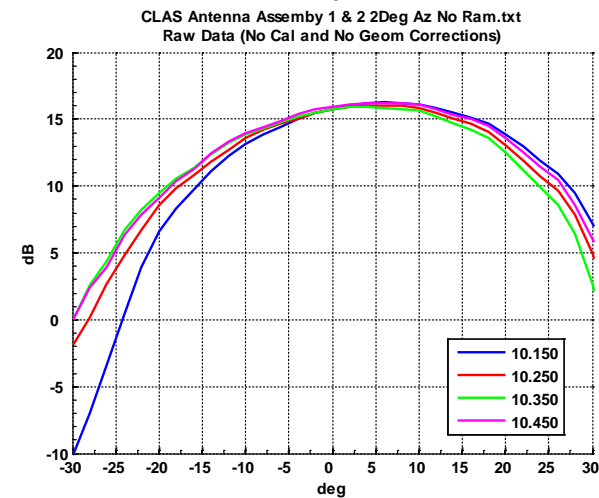
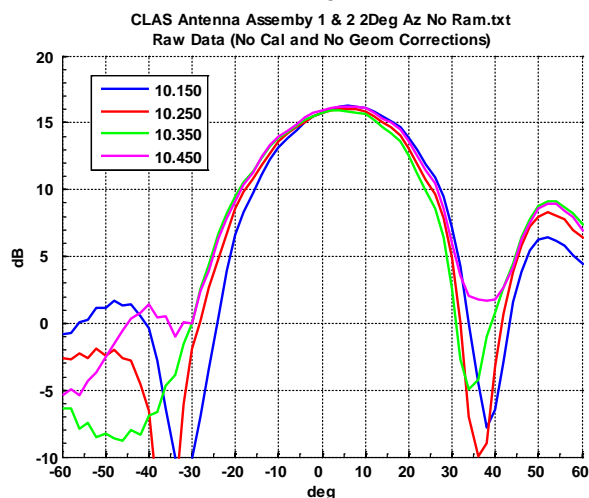
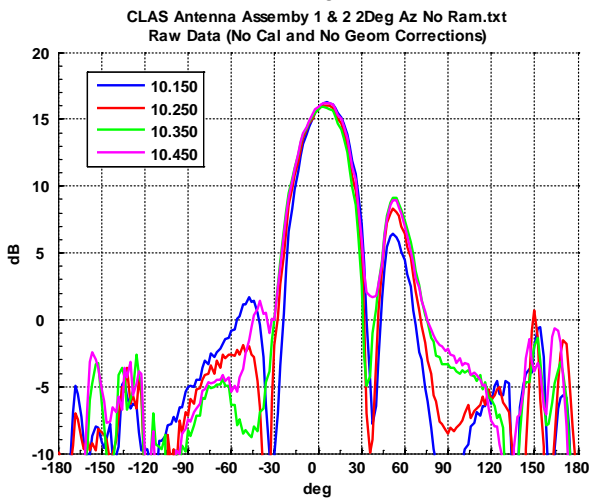
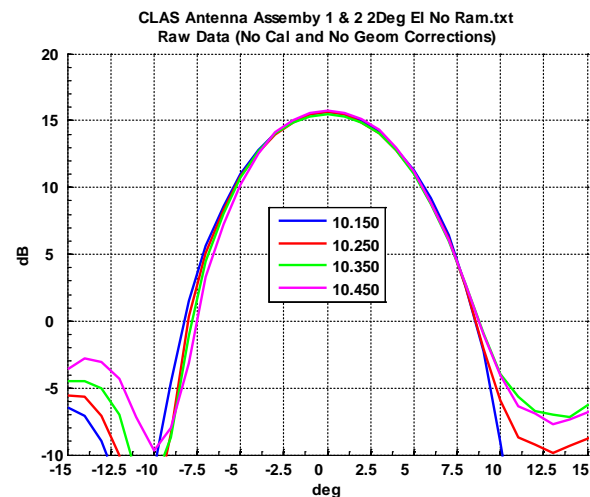
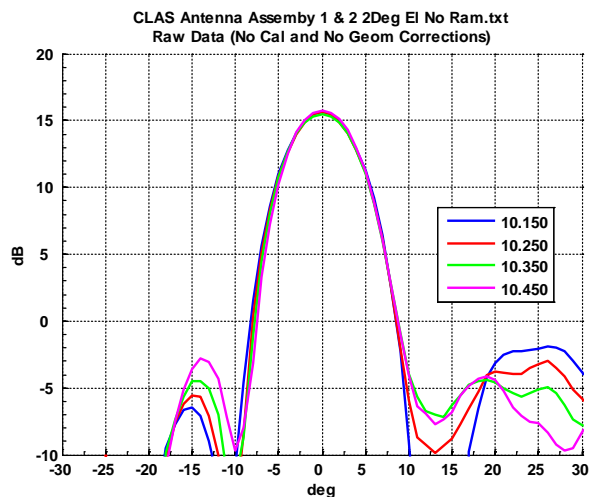
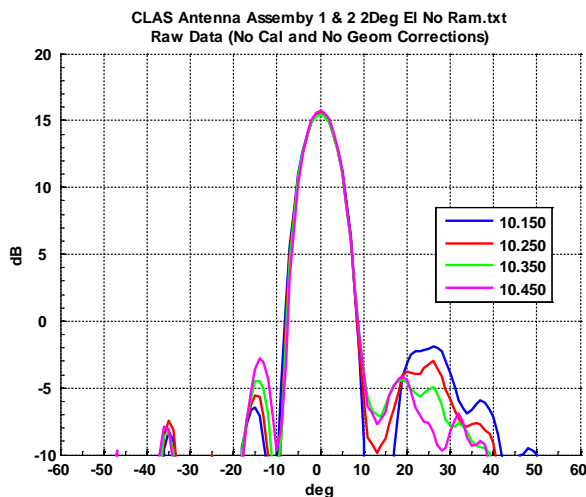

4-Stick, *No RAM* (Sticks 1+2)

BRC NanoSAR Demo

2 Sock, Epoxy Loaded Slots (190 probes, additional cleaning, internal sanding)

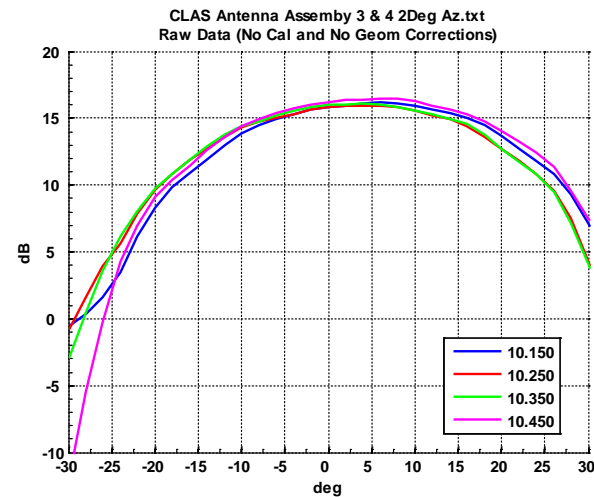
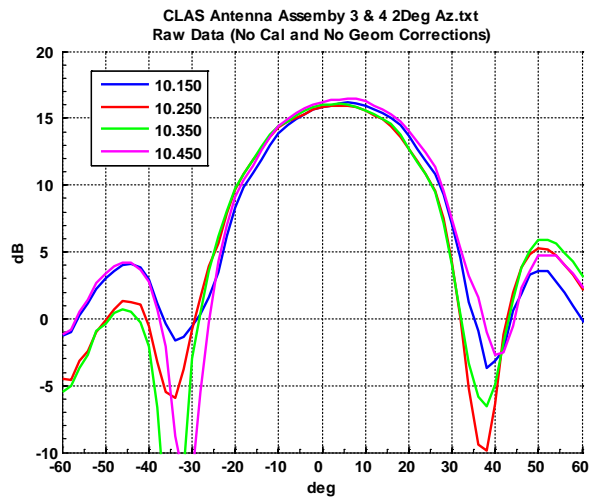
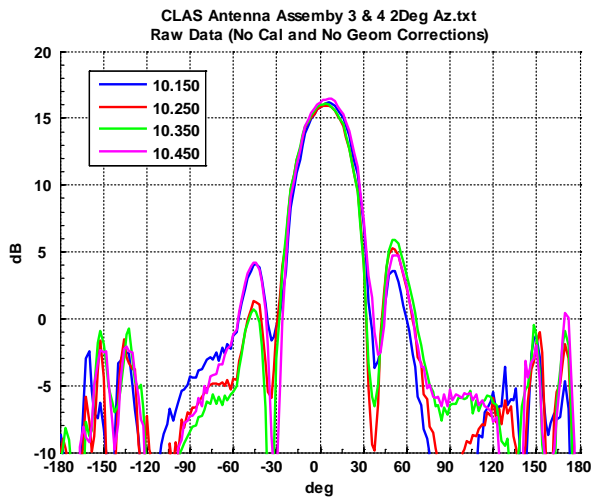
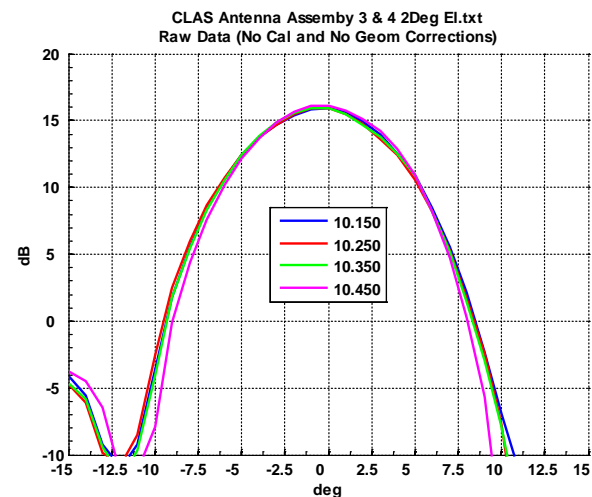
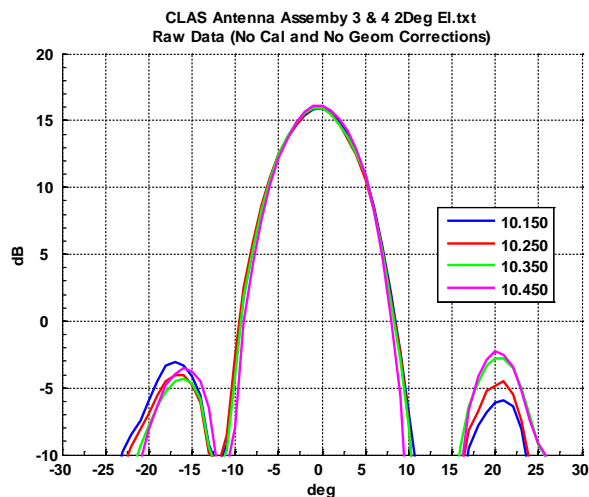
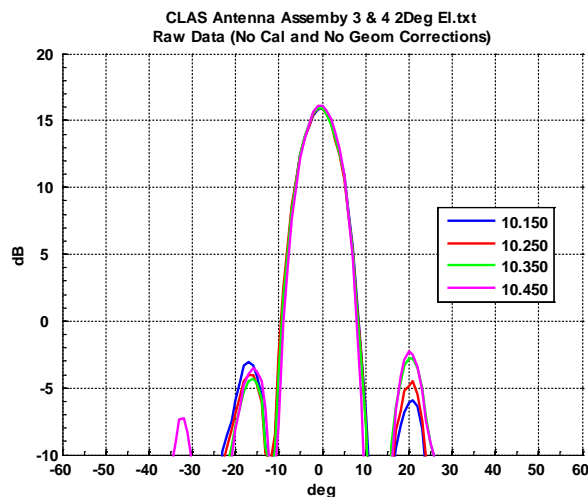

4-Stick, *No RAM* (Sticks 3+4)

BRC NanoSAR Demo

2 Sock, Epoxy Loaded Slots (190 probes, additional cleaning, internal sanding)

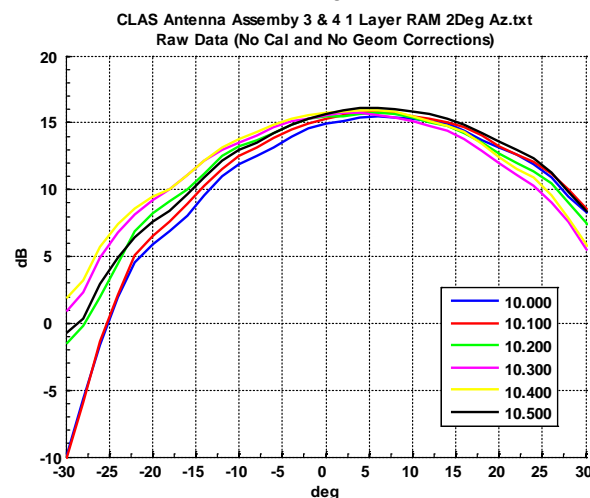
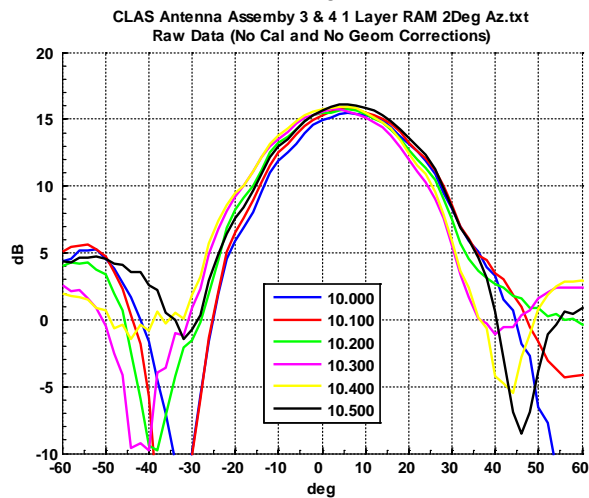
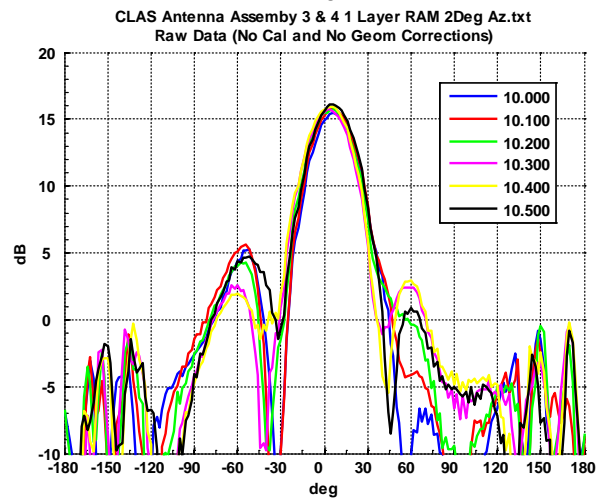
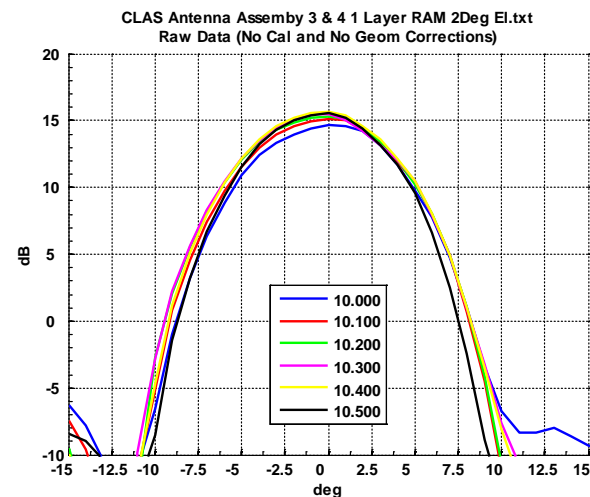
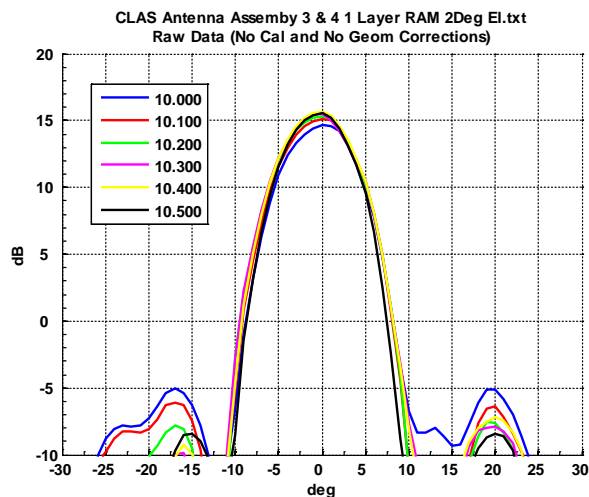
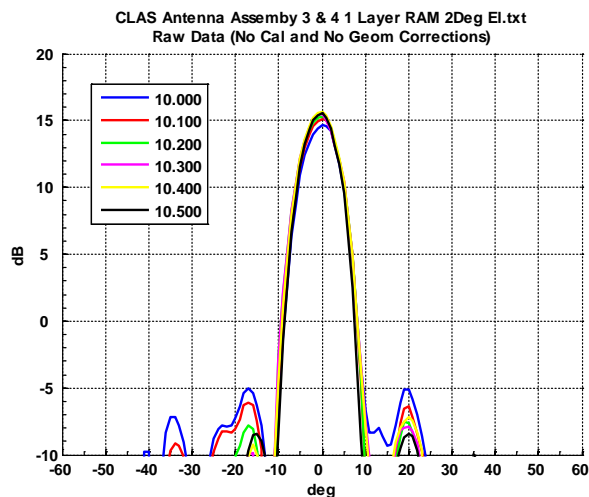

4-Stick, (Sticks 3+4 & 1 RAM Layer)

Sample Dual Slot Stick Configuration (Suitable for ImSAR Radar)

Substrate

- 10mil Thickness
- 13 mil Trace ($Z_0=51\Omega$)
- $Dk=6.15$ (e.g. Arlon TC600)
- ~ 0.38 dB Loss per inch

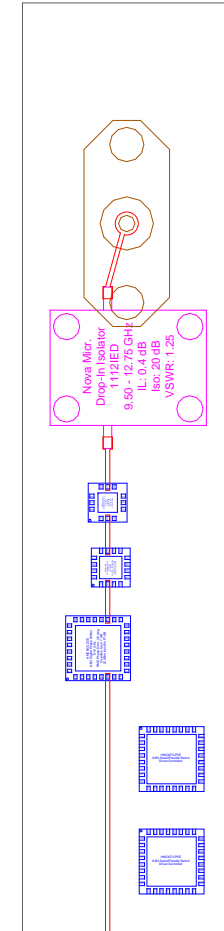
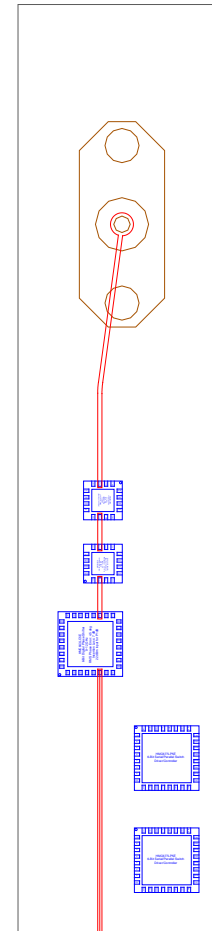
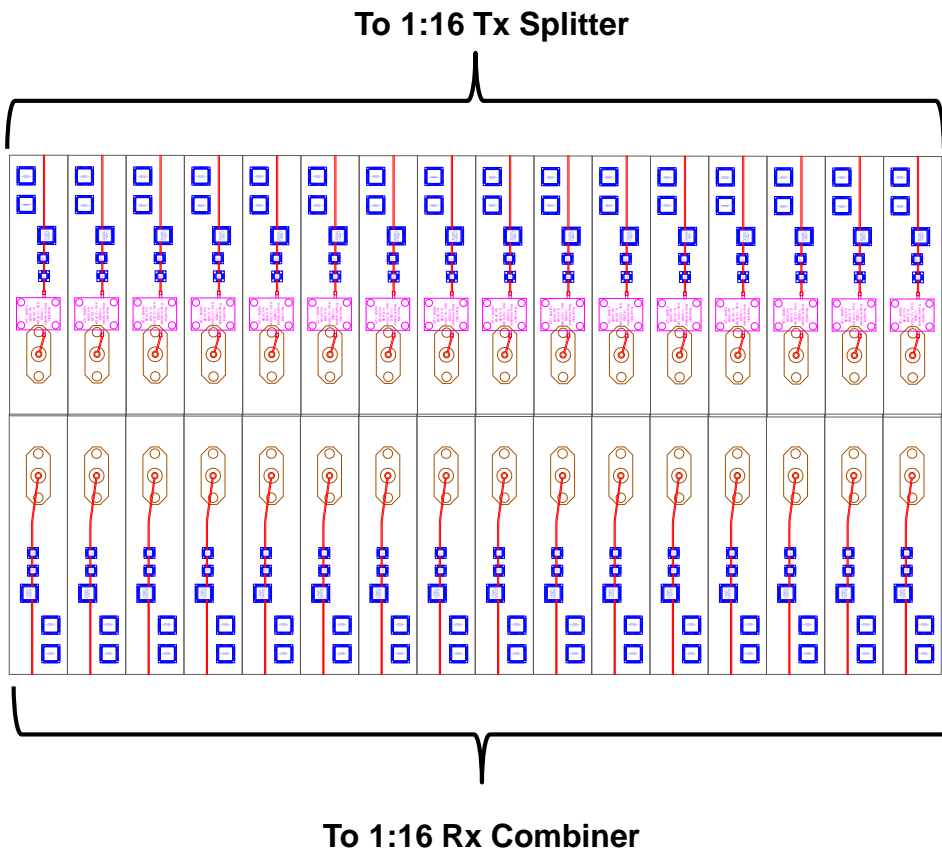

Quad Slot Sticks (16 Sticks) - 0° Azimuth Scan

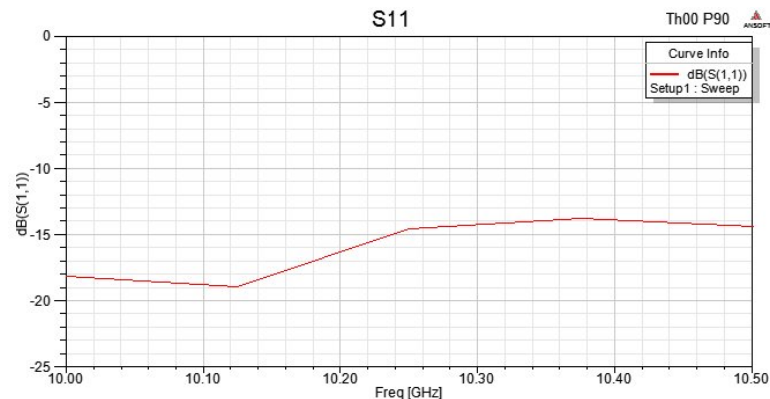
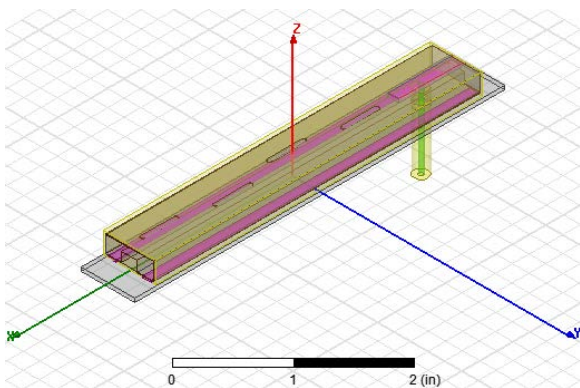

Active Impedance (0° Azimuth Scan)

Azimuth Side Lobes can be reduced via controlling the stick-to-stick power levels.

Elevation Pattern is likely too narrow for the ImSAR Radar

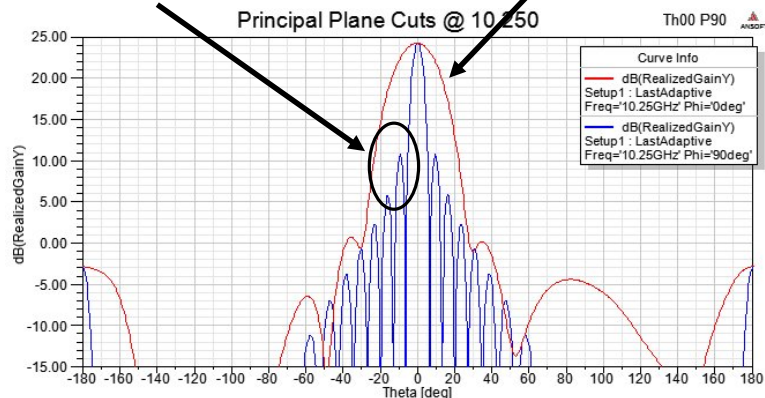

Principal Plane Patterns @ 10.250 GHz (0° AZ Scan)

Red: EL (X-Z Plane) Blue: AZ (Y-Z)

Pattern assumes 16 Sticks

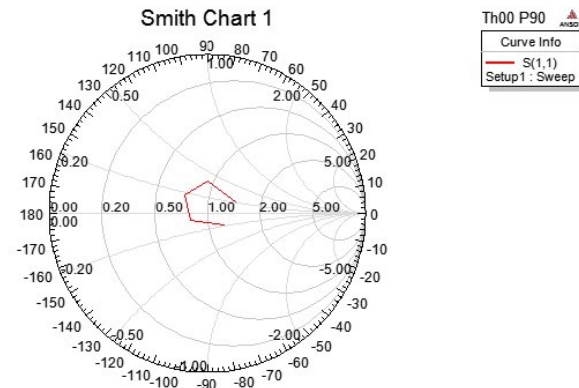

Active Impedance (0° Azimuth Scan)

Quad Slot Sticks (16 Sticks) - 20° Azimuth Scan

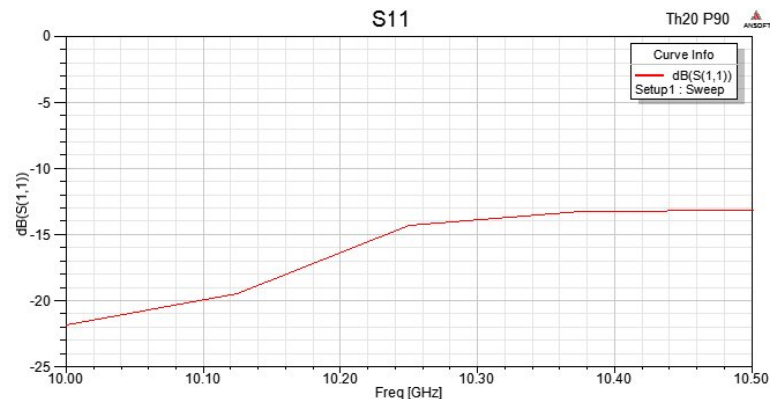
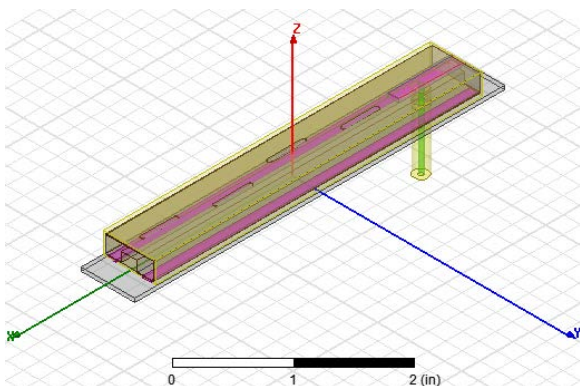

Active Impedance (20° Azimuth Scan)

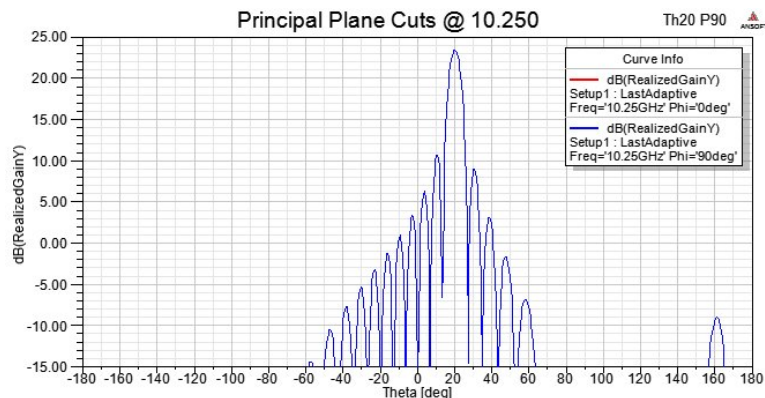

Principal Plane Patterns @ 10.250 GHz (20° AZ Scan)

Red: EL (X-Z Plane) Blue: AZ (Y-Z)

Pattern assumes 16 Sticks

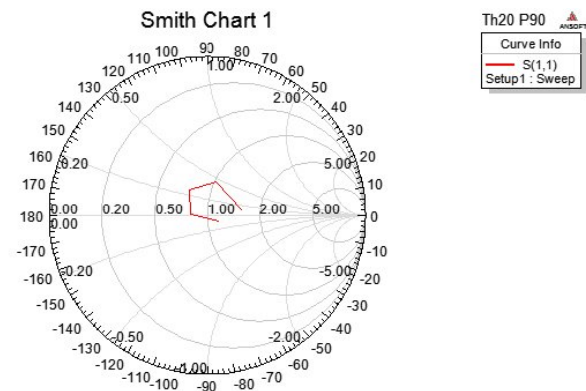

Active Impedance (20° Azimuth Scan)

Quad Slot Sticks (16 Sticks) - 30° Azimuth Scan

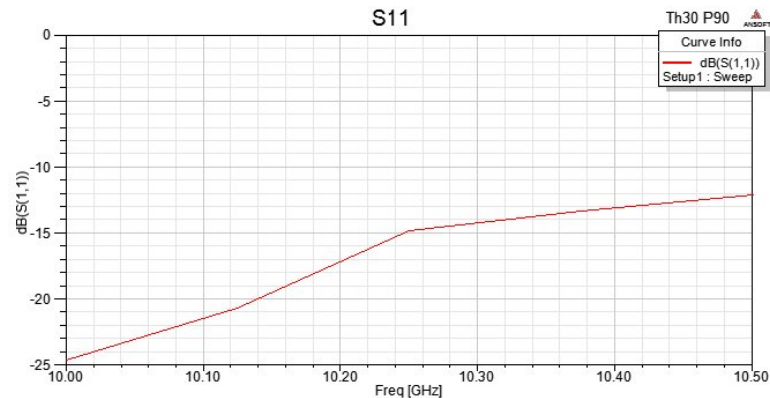
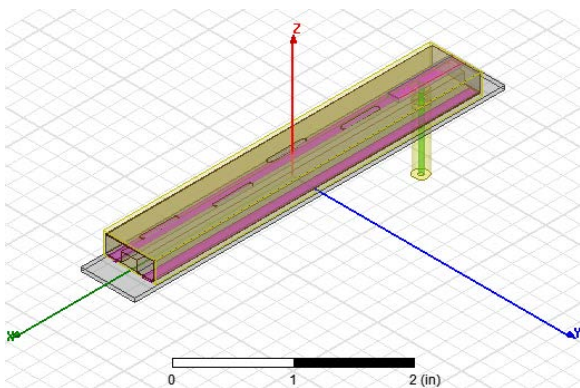

Active Impedance (30° Azimuth Scan)

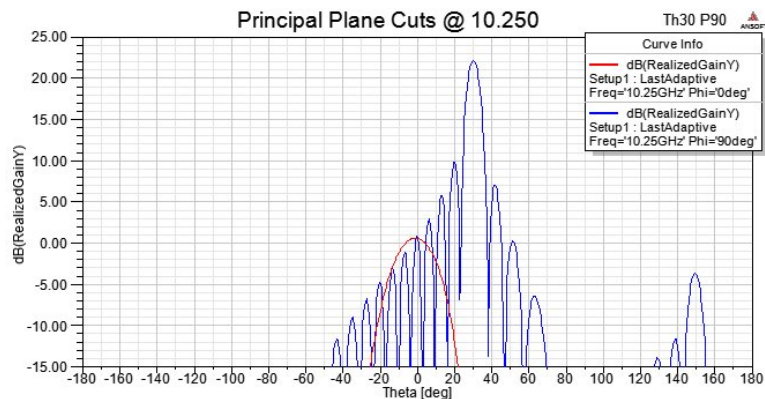

Principal Plane Patterns @ 10.250 GHz (30° AZ Scan)

Red: EL (X-Z Plane) Blue: AZ (Y-Z)

Pattern assumes 16 Sticks

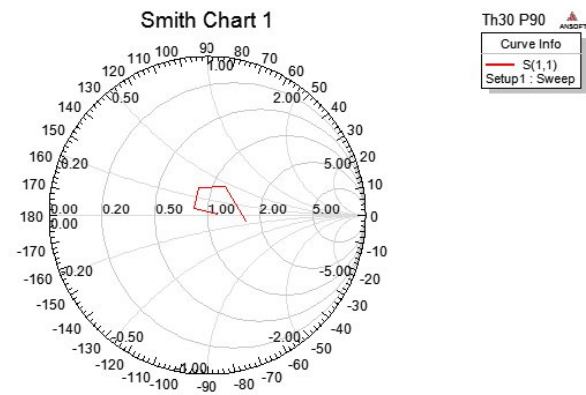

Active Impedance (30° Azimuth Scan)

Quad Slot Sticks (16 Sticks) - 40° Azimuth Scan

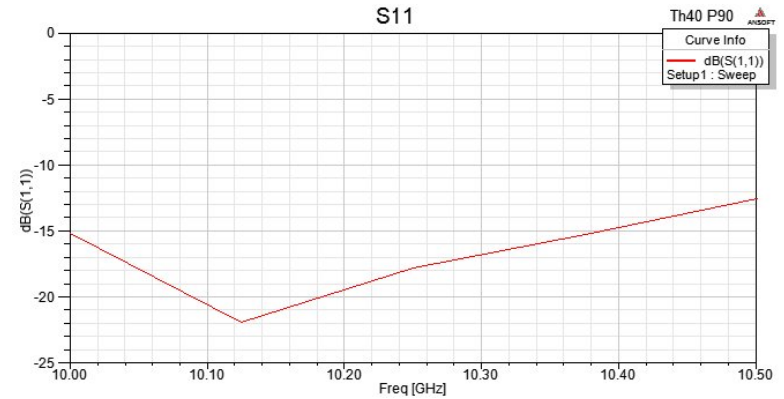
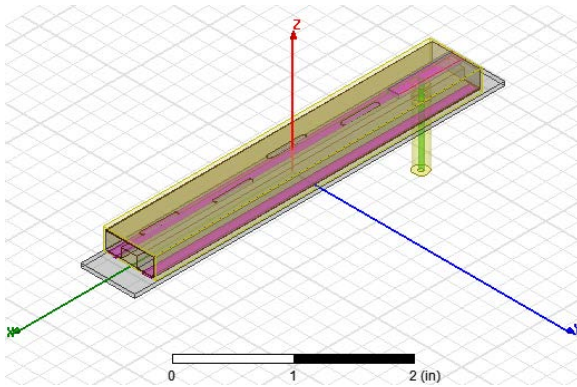

Active Impedance (40° Azimuth Scan)

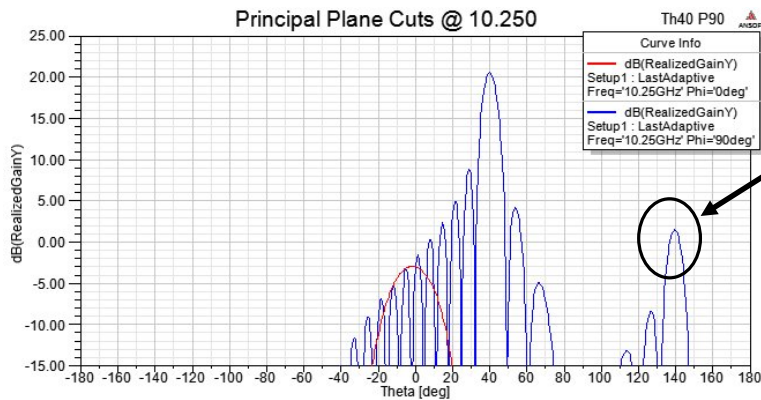

Principal Plane Patterns @ 10.250 GHz (40° AZ Scan)
 Red: EL (X-Z Plane) Blue: AZ (Y-Z)
 Pattern assumes 16 Sticks

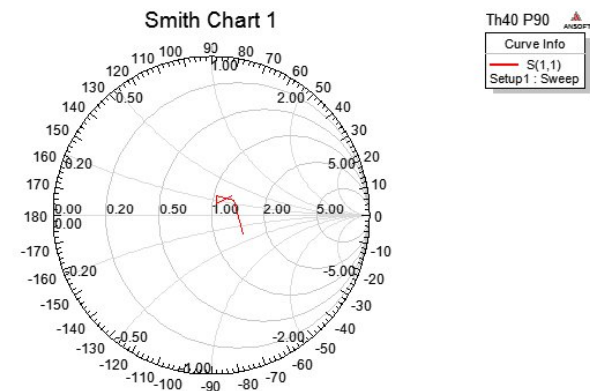

Active Impedance (40° Azimuth Scan)

Quad Slot Sticks (16 Sticks)

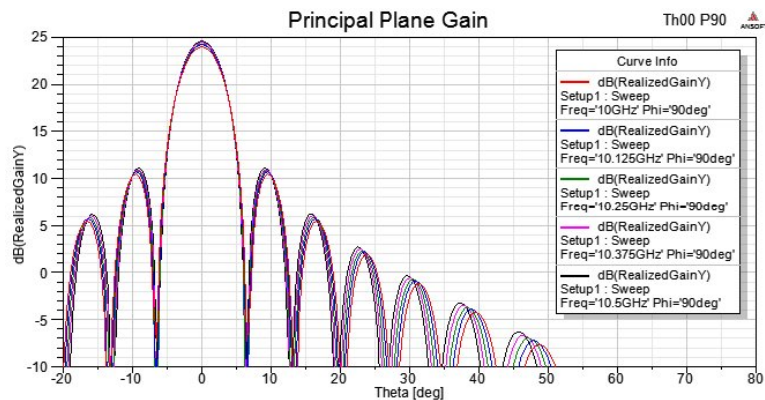

Azimuth Cuts at @ 0° AZ Scan
Pattern assumes 16 Sticks

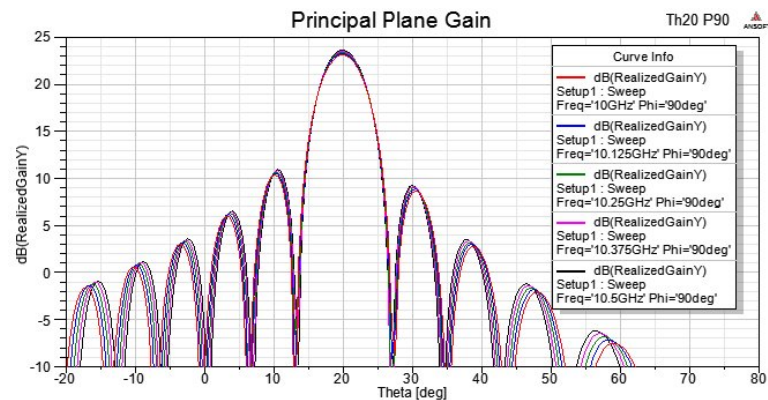

Azimuth Cuts at @ 20° AZ Scan
Pattern assumes 16 Sticks

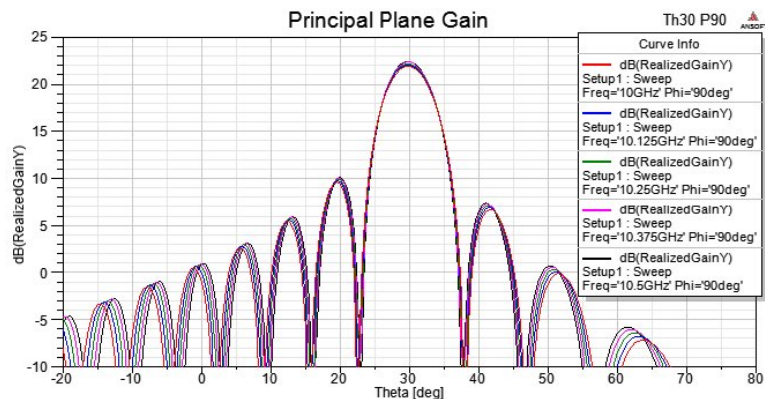

Azimuth Cuts at @ 30° AZ Scan
Pattern assumes 16 Sticks

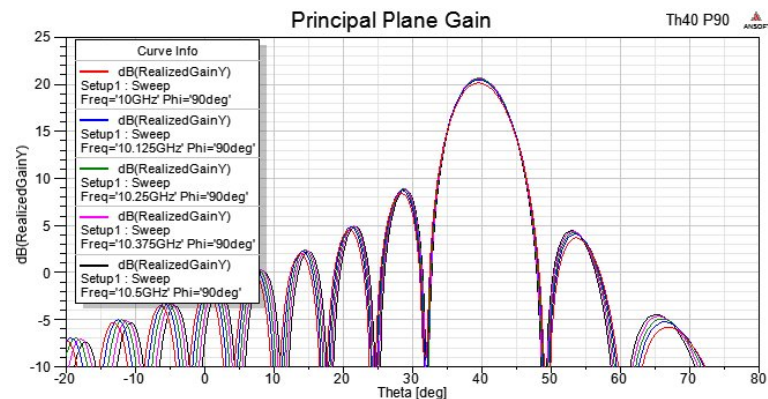

Azimuth Cuts at @ 40° AZ Scan
Pattern assumes 16 Sticks