**CRYOGENIC CERAMIC 277 WATT Yb: YAG THIN-DISK
LASER**

Natasa Vretenar, et al.

1 January 2012

Technical Paper

APPROVED FOR PUBLIC RELEASE; DISTRIBUTION IS UNLIMITED.



**AIR FORCE RESEARCH LABORATORY
Directed Energy Directorate
3550 Aberdeen Ave SE
AIR FORCE MATERIEL COMMAND
KIRTLAND AIR FORCE BASE, NM 87117-5776**

REPORT DOCUMENTATION PAGE			<i>Form Approved</i> OMB No. 0704-0188	
Public reporting burden for this collection of information is estimated to average 1 hour per response, including the time for reviewing instructions, searching existing data sources, gathering and maintaining the data needed, and completing and reviewing this collection of information. Send comments regarding this burden estimate or any other aspect of this collection of information, including suggestions for reducing this burden to Department of Defense, Washington Headquarters Services, Directorate for Information Operations and Reports (0704-0188), 1215 Jefferson Davis Highway, Suite 1204, Arlington, VA 22202-4302. Respondents should be aware that notwithstanding any other provision of law, no person shall be subject to any penalty for failing to comply with a collection of information if it does not display a currently valid OMB control number. PLEASE DO NOT RETURN YOUR FORM TO THE ABOVE ADDRESS.				
1. REPORT DATE (DD-MM-YYYY) 01-01-2012		2. REPORT TYPE Technical Paper		3. DATES COVERED (From - To) 01 January 2012
4. TITLE AND SUBTITLE Cryogenic Ceramic 277 watt Yb: YAG Thin-Disk Laser			5a. CONTRACT NUMBER	
			5b. GRANT NUMBER	
			5c. PROGRAM ELEMENT NUMBER	
6. AUTHOR(S) *Natasa Vretenar, Tim Newell, Tyler Carson, ***Phillip Peterson, ***Tim Lucas, William Latham, **Huseyin Bostanci, **Jennifer J. Huddler-Lindauer, **Benjamin A. Saarloos, **Dan Rini			5d. PROJECT NUMBER	
			5e. TASK NUMBER	
			5f. WORK UNIT NUMBER D010	
7. PERFORMING ORGANIZATION NAME(S) AND ADDRESS(ES) *University of New Mexico **RINI Technologies ***Boeing LTS Inc. 1313 Goddard SE 582 South Ecron Circle P.O. Box 5670 Albuquerque, NM 87106 Oviedo, FL 32765 Kirtland AFB, NM 87117			8. PERFORMING ORGANIZATION REPORT NUMBER	
9. SPONSORING / MONITORING AGENCY NAME(S) AND ADDRESS(ES) Air Force Research Laboratory 3550 Aberdeen Ave SE Kirtland AFB. NM 87117-5776			10. SPONSOR/MONITOR'S ACRONYM(S) AFRL/RDLT	
			11. SPONSOR/MONITOR'S REPORT NUMBER(S) AFRL-RD-PS-TP-2016-0018	
12. DISTRIBUTION / AVAILABILITY STATEMENT Approved for public release; distribution unlimited. 377ABW-2011-1229; 19 August 2011.				
13. SUPPLEMENTARY NOTES Accepted for publication in the 2012 Society of Photo-Optical Instrumentation Engineers (SPIE). [DOI: 10.1117/1.OE.51.1.014201. "Government Purpose Rights."]				
14. ABSTRACT A ceramic ytterbium:yttrium aluminum garnet (Yb:YAG) thindisk laser is investigated at 15°C (288 K) and also at 80 K, where it behaves as a four-level laser. We introduce a new two-phase spray cooling method to cool the Yb:YAG. One system relies on R134a refrigerant while the other uses liquid nitrogen (LN2). The use of two systems allows the same disk to be tested at the two temperatures. When the Yb:YAG is cooled from room to cryogenic temperatures, the lasing threshold drops from 155 W to near 10 W, while the slope efficiency increases from 54% to a 63%. A 277 W laser with 520 W of pump is demonstrated. We also model the thermal and structural properties at these two temperatures and estimate the beam quality.				
15. SUBJECT TERMS Laser Materials, Ytterbium Lasers, Solid-State Lasers, Diode-Pumped Lasers, Optical Materials.				
16. SECURITY CLASSIFICATION OF:			17. LIMITATION OF ABSTRACT SAR	18. NUMBER OF PAGES 10
a. REPORT Unclassified	b. ABSTRACT Unclassified	c. THIS PAGE Unclassified		
			19b. TELEPHONE NUMBER (include area code)	

Optical Engineering

SPIEDigitalLibrary.org/oe

Cryogenic ceramic 277 watt Yb:YAG thin-disk laser

Natasa Vretenar
Tim C. Newell
Tyler Carson
Phillip Peterson
Tim Lucas
William P. Latham
Huseyin Bostanci
Jennifer J. Huddle-Lindauer
Benjamin A. Saarloos
Dan Rini

Cryogenic ceramic 277 watt Yb:YAG thin-disk laser

Natasa Vretnar

University of New Mexico
Center for High Technology Materials
1313 Goddard SE
Albuquerque, New Mexico 87106

Tim C. Newell

Tyler Carson

Air Force Research Laboratory Directed Energy
Directorate
3550 Aberdeen Avenue SE
Kirtland Air Force Base, New Mexico 87117
E-mail: tim.newell@kirtland.af.mil

Phillip Peterson

Tim Lucas

Boeing LTS Inc.
P.O. Box 5670 MC RN-M1
Kirtland Air Force Base, New Mexico 87117

William P. Latham

Air Force Research Laboratory Directed Energy
Directorate
3550 Aberdeen Avenue SE
Kirtland Air Force Base, New Mexico 87117

Huseyin Bostanci

Jennifer J. Huddle-Lindauer

Benjamin A. Saarloos

Dan Rini

RINI Technologies
582 South Econ Circle
Oviedo, Florida 32765

Abstract. A ceramic ytterbium:yttrium aluminum garnet (Yb:YAG) thin-disk laser is investigated at 15°C (288 K) and also at 80 K, where it behaves as a four-level laser. We introduce a new two-phase spray cooling method to cool the Yb:YAG. One system relies on R134a refrigerant while the other uses liquid nitrogen (LN₂). The use of two systems allows the same disk to be tested at the two temperatures. When the Yb:YAG is cooled from room to cryogenic temperatures, the lasing threshold drops from 155 W to near 10 W, while the slope efficiency increases from 54% to a 63%. A 277 W laser with 520 W of pump is demonstrated. We also model the thermal and structural properties at these two temperatures and estimate the beam quality. © 2012 Society of Photo-Optical Instrumentation Engineers (SPIE). [DOI: 10.1117/1.OE.51.1.014201]

Subject terms: laser materials; ytterbium lasers; solid-state lasers; diode-pumped lasers; optical materials.

Paper 111032P received Aug. 24, 2011; revised manuscript received Nov. 1, 2011; accepted for publication Nov. 2, 2011; published online Feb. 9, 2012.

1 Introduction

Cryogenic solid-state laser materials offer many improvements in thermo/optical, structural, and lasing properties; all of which are noted in the following short literature review. Our first and foremost reference to the literature,¹ and perhaps one of the most relevant, pertains to the lasing properties of a relatively thick disk of 20-at.-%-doped Yb:YAG crystal. The maximum fiber coupled pump power was 12 W at a wavelength of 970 nm with a spot size of 0.4 mm. Kasamatsu, et al. studied various lasing characteristics over a temperature range of 80 to 300 K and noted a decrease in threshold and an increase in slope efficiency as the temperature decreases. Further, they demonstrated a maximum output lasing power at a temperature near 150 K. The next study² was a cryogenic Yb:YAG oscillator with a 15-mm, 5-at.-%-doped Yb:YAG crystal sandwiched between two undoped YAG caps maintained near 100 K. A 165 W output for an input of 215 W gave a slope efficiency of 85%, optical-to-optical efficiency of 76%, and a threshold near 22 W. Later the same institution³ returned to a similar configuration and measured a threshold

of 50 W, an optical-to-optical efficiency of 60%, and a pump power of 500 W that gave an output of around 300 W. In the intervening years⁴ a cryogenic sapphire-Yb:YAG sandwich yielded a 75 W output at a pump power of 106 W with an optical-to-optical efficiency of 70% and a slope efficiency of 80%. In a study initiated in 2007 and continued into subsequent years,^{5,6} multiple cryogenic sapphire-sandwiched Yb:YAG disks eventually gave an optical-to-optical efficiency of 42.2% with an output of 963 W for an input of 1871 W.⁷ The introduction of a total-reflection active mirror (TRAM) Yb:YAG disk sandwiched between a trapezoidal YAG prism and a liquid nitrogen (LN₂) bath gave 275 W, an optical-to-optical efficiency of 65%, and a slope efficiency of 72% at an absorbed power of 450 W.⁸⁻¹⁰ Finally, we note a paper on cryogenic Yb:YAG 10-at.-%-doped crystal at high peak and average power.¹¹ They obtained 0.5 J at a 1-kHz rate and in doing so measured the small signal gain and showed that it rolls over at a pump power of 200 to 300 W for a spot size of 6 mm.

In the following sections we report the improvement in extraction, threshold, and distortion of a cryogenic ceramic Yb:YAG thin-disk laser operating at initial temperatures near 80 K, as compared to the same system operating near 280 K.

These correspond to LN₂ and R134a coolants. We show that for the same resonator the threshold drops dramatically by a factor of 50 while the slope efficiency changes from 54% (280 K) to 63% (80 K). These changes are all, for the most part, manifestations of the differences between quasi three-level and four-level Yb:YAG.

In contrast to the study by Kasamatsu, et al.,¹ we are interested in the scalability of cryogenic thin-disk lasers, and so we use a disk 3.5 times thinner with a pump beam size 17.5 times larger. This design addresses thermal and structural issues as well as disk and bonding failures attendant with small spot sizes. Additionally, high-power pumping at low temperatures becomes more difficult due to absorption spectral narrowing, and so we have shifted to a pump wavelength from 969 nm to 940 nm.

2 Experimental

Figure 1 shows a 2-D cross section of our setup. The evaporative spray cooling (ESC) nozzle unit (S) directs coolant into the interior of the cooling cap (C). Yb:YAG is attached to the cap using a void-free thin layer of indium solder. The pump is introduced into the cavity through the lens train (L). The pump is actually out of plane and does not propagate through the mirror (M2). It reflects off the one-piece parabolic mirror (M3) and corner mirrors (M1 and M2) are shown, and two additional corner mirrors are perpendicular to the plane of the paper, onto the disk surface to image the light for 16 passes of absorption.¹¹) The laser cavity is defined on one end by the ion-beam sputtered HR (>99.9%) coatings applied to the Yb:YAG and the output coupler (OC $R = 95$ to 99%) on the other. The resonator is approximately 35 cm long.

To manage the high heat loads, an advanced two-phase ESC technique developed by the RINI Corporation (Oviedo, FL) is utilized. Two versions were constructed. R134a refrigerant is one coolant. This system can maintain the disk temperature from 268 to 290 K and is capable of removing heat fluxes of up to 200 W/cm² with a convective heat transfer coefficient of 125,000 W/m² K. The convective heat transfer coefficient h , is defined by $h = q''/\Delta T_{\text{sat}}$. q'' is the heat flux ($q'' = Q/A$ where Q is the total heat load and A is the heat transfer area) and ΔT_{sat} is the difference between the spray surface temperature and the coolant saturation temperature. A second system uses LN₂, allowing laser operation near 77 K. Traditional LN₂ cryostats are limited to heat fluxes on the order of 20 – 25 W/cm². The two-phase ESC technique consistently removes heat fluxes of 100 W/cm² and has even removed heat fluxes as high as 160 W/cm² with a convective heat transfer coefficient of 80,000 W/m² K. In order to put these heat transfer coefficient values in perspective,

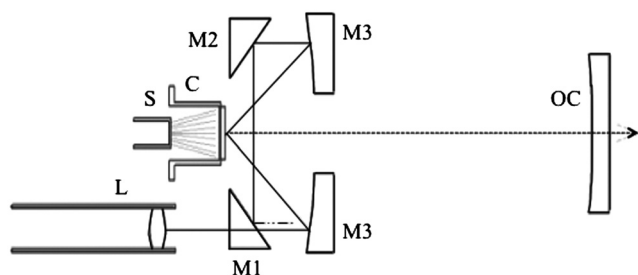

Fig. 1 Experimental setup.

other commonly utilized cooling technologies can be considered for their respective performance. A typical natural convection with gases provides only 25 W/m² K, while forced convection with liquids, such as jet impingement, could achieve 20,000 to 50,000 W/m² K. Besides its high heat transfer performance, ESC allows very efficient coolant usage and results in lightweight and compact thermal management schemes. The ESC system in this work features an open-cycle design comprised of a nozzle located at the bottom of a stainless steel reservoir mounted on a base. The reservoir is designed to vent excess bubbles generated by an ambient heat leak, thus enabling a consistent spray. Heat generated by the thin-disk is removed by the liquid droplets impinging on the inner surface of the interface cap and vaporizing that cools the crystal through a two-phase heat transfer process. The generated vapor and any remaining liquid exit an exhaust fitting on the base section of the reservoir/nozzle assembly.

In the laboratory experiments, the difference between the two systems is the cavity environment. For cryogenic operation, the entire thin-disk laser is placed within a vacuum chamber so as to eliminate the ambient humidity. Air in the chamber is initially evacuated, and then the dry gas overflow of LN₂ is introduced to create a slight overpressure. This setup is sufficient to prevent condensation on optical surfaces and to cool the optics. The pump light is coupled through a port, necessitating a different set of optics to effectively collimate and launch the pump light onto the thin-disk resonator. This resulted in a modest degradation in the cumulative beam that is incident on the disk surface. In either case, the laser pump power is increased slowly so as to allow a thermopile detector time to settle. For room temperature operation (R134a), a thermal camera is imaged onto the disk surface to track the surface temperature increase. The camera was not calibrated at cryogenic temperatures and not used when the disk was LN₂-cooled.

The thin disk is void-free indium soldered to the mounting cap. A fluxless indium soldering process was developed by Precision Photonics (Boulder, CO) and Enerdyne Solutions (North Bend, WA). The mounting worked well for both cryogenic and room temperature operation. Both capped and uncapped ceramic Yb:YAG thin-disk gain material were tested. The uncapped gain media is 200 μm thick, 9.8% Yb-doped, 14 mm in diameter provided by Konoshima Corporation (Japan). The gain media is coated with a high reflective coating on one end. Capped thin-disks have the gain media bonded to undoped and antireflection coated for 940/1030 nm YAG. Precision Photonics bonds them using the chemically activated direct bonding (CADB) technique.

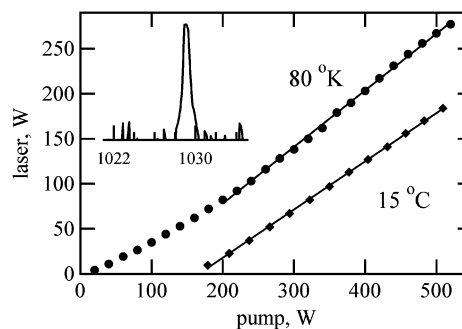

Fig. 2 Lasing power versus pump power at 15°C (288 K) and 80 K.

Figure 2 shows the lasing power versus the incident pump power at 15°C and 80 K. The inset spectral peak in Fig. 2 is the 80 K laser output and is centered near 1029.1 nm. At room temperatures this peak is near 1030.2 nm. The resonator uses a 98% reflective output coupler with a 2-m radius of curvature. The pump spot size is approximately 7 mm at room temperature with a nearly top hat profile. In the cryogenic case the profile is not an ideal flat top and has a spot size slightly greater than 7 mm. The room-temperature lowest lasing threshold is 155 W, at which point the disk surface temperature is 308 K. The slope efficiency is 54%, which remained linear throughout the pump range. At 510 W pump, the power reached 184 W.

In stark contrast to the R134a results, Fig. 2 shows that the cryogenic laser threshold plummets to near 10 W. This is a clear demonstration of the superiority of a four-level laser over the quasi three-level system. It also shows the improvement in emission and absorption cross sections at cold temperatures. For the cryogenic operation, the initial slope efficiency was only 43%. Above 200 W pump, the efficiency increased to 63% and remained linear beyond this point. At 520 W pump, the maximum power achieved was 277 W. We believe that this increase in slope efficiency can be traced to two factors. The first factor is the pump wavelength, which is just above 932 nm at low powers. The diode junction heats as the driving current increases, causing a wavelength red-shift of 0.0076 nm/W. At cryogenic temperatures the absorption cross-section increases substantially as the wavelength shifts from 932 to 935 nm. Thus the absorbed pump increases super-linearly with respect to the incident pump. Attempts to red-shift the light via the cooling water temperature were unsuccessful. In contrast, at room temperature the absorption profile increases slowly at these wavelengths. A second reason for the improvement is the lack of the ideal top hat shape of the pump spot. At powers very near threshold, the laser operates with few transverse modes oscillating. Yb at the center of the disk is inverted prior to the periphery. As the pump power increases, more modes reach the threshold condition and augment the total power. This effect is quite small but observable. Plotting the cryogenic laser power versus the absorbed pump would likely result in a linear slope with an efficiency superior to 63%. However, the resonator design prevented us from measuring the residual pump, and so the absorbed pump values would be an undesirable computed estimate.

Figure 3 shows the on-axis spontaneous emission when the thin disk is pumped with a low-power, 25-W, 915-nm pump source. No output coupler optic is in place. The material is ceramic Yb:YAG rather than crystal; the latter has been reported previously.³ The initial spectral sweep

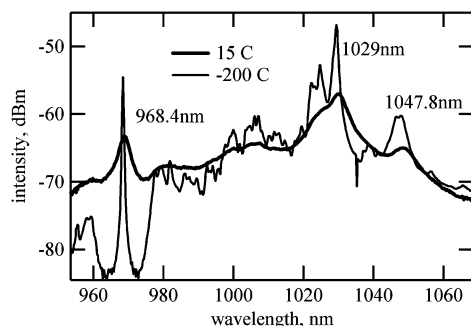

Fig. 3 Emission spectra at 15°C (288 K) and 80 K.

is taken at 15°C using a fiber probe positioned near the surface of the disk. The disk is subsequently cooled to 80 K and the measurement repeated. The integrated emission curves show that the emission at cryogenic temperatures is 1.8 times greater than the room temperature emission. Interestingly, there is a strong dip in the cryogenic emission spectra around the 968-nm zero-phonon line, which is due to the reduction in homogeneous broadening. The width of this dip is 8.2 nm on both sides of the line, and for ceramic thin disk the dip is not symmetrical. Note that the low temperature behavior around the zero phonon line is the major difference between ceramic and crystal emission spectra. Specifically, at low temperatures the crystal emission is symmetric and narrower than the asymmetric ceramic emission.

In the lasing situation, amplified spontaneous emission (ASE) emitted at a high angle (~ 80 deg) off of the optical axis of the disk was measured. This spectrum is not shown because it is very similar to the emission shown in Fig. 3. The emission peaks are amplified and narrowed. Instead of comparing ASE spectra between room and cryogenic cases, which is difficult due to different experimental arrangements and power levels, we examine the relative differences in the spectra in Fig. 3. For example, the collection angle of the fiber and its position is similar between the room and cryogenic experiments, but not identical due to a difference in the setup. Light is coupled into a 50- μm multimode fiber attached to an Agilent 86146B Optical Spectrum Analyzer. The pump laser power is 180 W, giving laser outputs of $P_{80^\circ\text{K}} = 72$ W, $P_{288^\circ\text{K}} = 7$ W. The predominant emission is scattered lasing light at 1030 nm (1029 nm at cryogenic). At 80 K there is a strong reduction in emission away from the laser line. The zero-phonon 969 nm line is 17.1 dB less than the 1029 nm peak while the peak at 1048.8 nm is 20.23 dB lower. In contrast, at room temperature the 969 nm and 1048.8 nm peaks are only 4.4 dB and 8.2 dB less than the laser peak intensity. As suggested in Fig. 2, there is a strong reduction in spurious ASE generated when Yb:YAG behaves as a four-level laser. Great effort has been spent on suppressing the ASE in the radial direction (undoped caps or beveled edges, for example). Broad band ASE is suppressed in the four-level case due to a sharpening of the emission lines. The large gain cross-section on the lasing line enhances stimulated emission into the lasing mode.

The 98% output coupler optic and 0.2-mm disk thickness are optimal for R134a or water cooling methods. It is not likely to be so for the cryogenic case. They were used here for direct comparison. Brown¹² computed pump absorption optimization at room and cryogenic temperatures as a function of pump wavelength and the optical thickness (doping density \times penetration distance), which can be applied here experimentally. Furthermore, Contag¹³ computed that the optical efficiency approaches $\sim 85\%$ at low temperatures regardless of the number of pump passes on the disk surface. Hence another parameter to consider is the number of pump passes. It is simpler and easier to experimentally align a few-pass resonator than the 8-pass one used here. These options make the cryogenic thin-disk laser an appealing system to simultaneously pursue very high power and efficient lasers.

We modeled our cryogenic disk/mount structure using the Finite Element Model (FEM) software COMSOL. Figures 4 and 5 show the temperatures and deformation of the disk/

mount for R134a (Fig. 4) and LN₂ (Fig. 5) cooling temperatures. Both figures show the outline of the undeformed disk (black lines): in Fig. 4 the topmost rectangle is the anti-ASE cap, while in Fig. 5 the topmost rectangle is the Yb gain

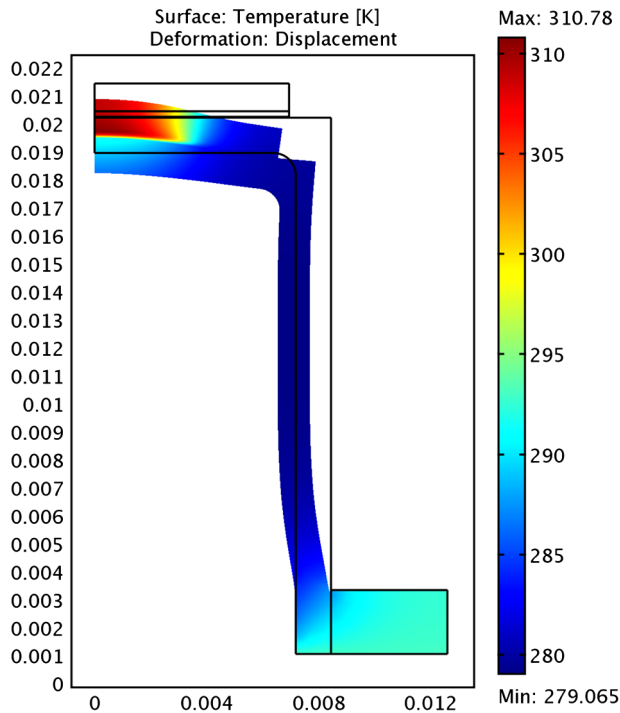

Fig. 4 Thermal and structural plot for R134a. The topmost rectangle is the anti-ASE cap. Note the outline in black line of the undeformed disk/mount.

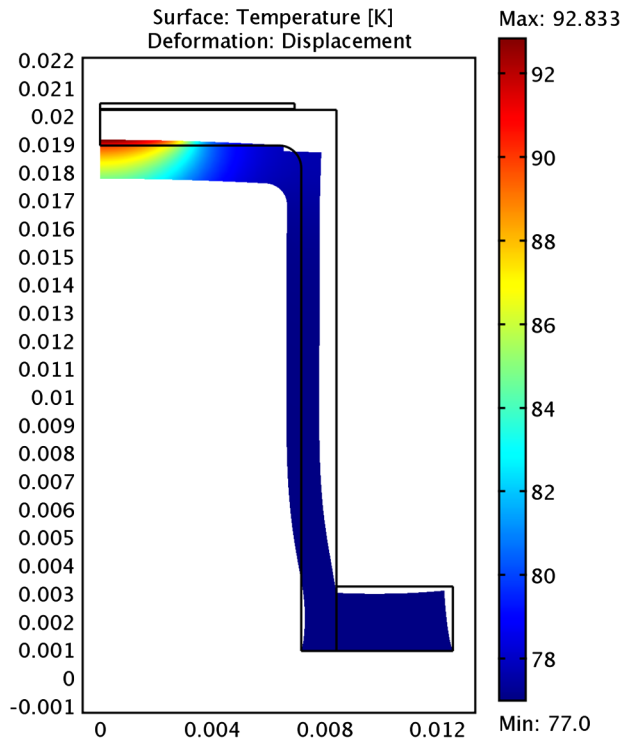

Fig. 5 Thermal and structural plot for LN₂ cooling. The topmost rectangle is the Yb:YAG gain medium. Note the outline in black line of the undeformed disk/mount.

medium. These figures are a cross-section of the rotationally symmetric disk/mount shown in Fig. 6. Further, the disk in Fig. 4 has a YAG anti-ASE cap while the disk in Fig. 5 is without a cap. The cap is a 1-mm YAG disk that is index-matched to the active 200 μm thick Yb:YAG. This reduces the trapped ASE rays in the doped region and hence decreases heating. These two disk configurations were determined by availability of disks and experimental constraints. The thermal/structural constants of Yb:YAG at these two temperatures are: R134a, $K = 5 \text{ W/m}^2\text{K}$, $E = 280 \times 10^9 \text{ Pa}$, $\alpha = 7.6 \times 10^{-6}/^\circ\text{K}$; LN₂, $K = 40 \text{ W/m}^2\text{K}$, $E = 311 \times 10^9 \text{ Pa}$, $\alpha = 2, 1 \times 10^{-6}/^\circ\text{K}$. K is the thermal conductivity, E is Young's constant, and α is the thermal expansion coefficient. For the Yb cap $K = 10 \text{ W/m}^2\text{K}$. A 33- μm layer of indium solder layer lies between the Yb:YAG and cap. Indium material parameters are determined by COMSOL default values.

For these experiments the maximum pump power is 520 W, which gives a pump intensity of 0.13 kW/cm² for a spot size of 7 mm. The photon efficiency is about 10% and for an absorption coefficient of 1000/m, the heat load is 1.3 kW/cm³. The dependence of this and ASE on pump power is discussed in Ref. 14. The absorbed heat load is modeled as a ninth order super-Gaussian profile. Returning to Figs. 4 and 5, note that in the figures the deformation is not to scale, but is generated as COMSOL's default value. The coloring in these figures shows the temperature distribution of the cross section. The R134a disk shows a maximum temperature at the center of 309 K with a decrease of 16 K at the edge of the spot size and a drop of 28 K across the entire disk. For the LN₂ case, the center temperature is 93 K to 84 K at the end of the pump spot size and a 15 K drop across the entire disk to 78 K. Thus, for the same heat load the cryogenic temperature variation across the disk surface is about half of the R134a temperatures. The deformation in Figs. 4 and 5 shows that the side of the mount caves in as the disk bends convexly. A more detailed view of the deformation is shown in Figs. 7 and 8 for the top and bottom of the 200- μm Yb:YAG gain layer. These surfaces are important because the bottom is the HR side and presents a curvature to the cavity. The difference between the top and bottom contribute to the dn/dT and stress phases. The major difference between Figs. 7 and 8 is that the entire disk is pulled down by 24 μm due to cooling of the mount at LN₂ temperatures;

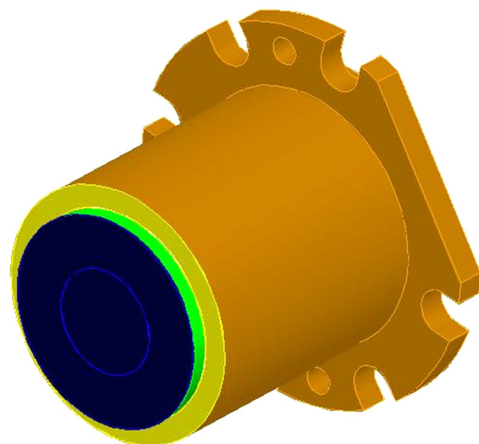

Fig. 6 CuW mount for the Yb:YAG disk.

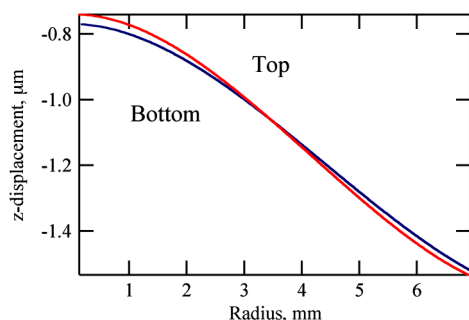

Fig. 7 Gain medium displacement for R134a cooling.

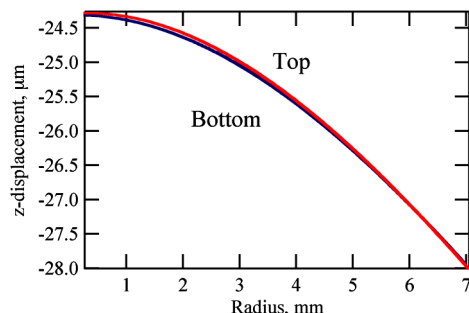

Fig. 8 Gain medium displacement for LN₂ cooling.

at R134a temperatures this does not occur. However, they show a sag of 0.2 μm for the R134a case and a 2- μm sag for the LN₂ case, both across the pump beam spot size. Finally, we briefly note the stresses. For the uncapped disk at cryogenic temperatures, both the radial and azimuthal stress is compressive and uniform, except at the edge. However, for the capped disk at near-room temperatures, the azimuthal stress is compressive up to the beam edge then tensile to the edge caused by the radial tensile stress in the unpumped gain volume. This nonuniformity can lead to disk and bonding failure.

Our thin-disk laser, as well as most others, is inherently multimode. An estimate for the beam quality M^2 is calculated by assuming that M is proportional to the radius of the pump spot r_p , divided by the lowest loss Gaussian beam radius on the thin disk surface w_o , thus $M^2 = (ar_p/w_o)^2$. For a thin-disk laser, Giesen¹⁵ sets $\alpha = 0.85$, which gives a M^2 value near 35. The beam quality can be further degraded by disk bowing or refractive index changes, dn/dT . Experiments were performed using a probe beam reflected from the surface of the disk and into a Shack-Hartmann wavefront analyzer. These revealed that in the lasing situation the disk can slightly bow with increasing laser power but that no thermal lensing occurs.

3 Summary

In summary, we demonstrated that cooling a 0.2-mm thick, 14-mm diameter, 9%-Yb-doped ceramic Yb:YAG thin-disk from 15°C (288 K) down to 80 K results in a laser threshold drop from 155 W to near 10 W. In concert, the cryogenic slope efficiency reached 63%, and the laser generated 277 W from a 520-W pump. A novel two-phase spray cooling method mitigates the heat produced within the Yb:YAG. Two systems, one using R134a and LN₂ for the other,

were built. Yb:YAG disks were indium-mounted to CuW caps that are interchangeable between the two systems. Hence the same disk was tested with cooling at 288 K (R134a) and also at 80 K (LN₂). Material damage due to cycling the temperature from room to 80 K was not observed. This is ostensibly due to the soft and thick indium layer that buffers the tensile strain of the cap on the disk. These initial cryogenic results can be readily improved with wavelength stabilized pump diodes, minor refinements to the pump coupling, and optimization of the material characteristics.

Acknowledgments

The authors would like to thank the High Energy Laser–Joint Technology Office (JTO-HEL) for support and Mr. M. Revak for technical assistance. Natasa Vretenar would like to thank the Air Force Office of Scientific Research (AFOSR) for support under grant FA9550-10-1-0463.

References

1. T. Kasamatsu, H. Sekita, and Y. Kuwano, "Temperature dependent and optimization of 970-nm diode-pumped Yb:YAG and Yb:LuAG lasers," *Applied Opt.* **38**(24), 5149–5153 (1999).
2. D. J. Ripin et al., "165-W cryogenically cooled Yb:YAG laser," *Opt. Lett.* **29**(18), 2154–2156 (2004).
3. T. Y. Fan et al., "Cryogenic Yb³⁺-doped solid-state lasers," *IEEE J. Sel. Top. Quantum Electron.* **13**(3), 448–459 (2007).
4. S. Tokita et al., "Sapphire end-cooling of high-power cryogenic Yb:YAG disk laser," *2005 Conference on Lasers and Electro-Optics Europe, CTu3-4* (2005).
5. D. C. Brown et al., "Innovative high-power CW Yb:YAG cryogenic laser," *Proc. SPIE* **6552**, 65520D-1 (2007).
6. D. C. Brown et al., "Kilowatt class high-power CW Yb:YAG cryogenic laser," *Proc. SPIE* **6952**, 69520K (2008).
7. D. C. Brown et al., "High sustained average power cw and ultrafast Yb:YAG near-diffraction-limited cryogenic solid-state laser," *Opt. Express* **18**(24), 24770–24792 (2010).
8. H. Furuse et al., "Total-reflection active-mirror laser with cryogenic Yb:YAG ceramics," *Opt. Lett.* **34**(21), 3439–3441 (2009).
9. H. Furuse et al., "Thermal effect of cryogenic Yb:YAG total-reflection active-mirror laser," *Proc. SPIE* **7578**, 75780I (2010).
10. J. Kawanaka et al., "Highly efficient cryogenically-cooled Yb:YAG laser," *Phys. of Lasers* **20**(5), 1079–1084 (2010).
11. I. Mukhin et al., "Cryogenic disk laser with high peak and average power," in *High Intensity Lasers and High Field Phenomena*, OSA Technical Digest, Optical Society of America, paper HThE4 (2011).
12. D. C. Brown, "Yb:YAG absorption at ambient and cryogenic temperatures," *IEEE J. Sel. Top. Quantum Electron.* **11**(3), 604–612 (2005).
13. K. Contag et al., "Theoretical modeling and experimental investigations of the diode-pumped thin-disk Yb:YAG lasers," *Quant. Elect.* **29**(8), 697–703 (1999).
14. P. Peterson et al., "ASE in thin disk lasers: theory and experiment," *Opt. Express* **19**, 25672–25684 (2011).
15. Adolph Giesen, Dausinger + Giesen GmbH, Stuttgart, Germany, private communication (2005).

Natasa Vretenar received her PhD from the University of New Mexico in December 2011. She has also worked in industry as an optical engineer.

Tim C. Newell earned his PhD in 1994 from the University of North Texas, and has performed research in semiconductor quantum well and quantum dot lasers, narrow linewidth fiber amplifiers, and Yb:YAG thin-disk lasers.

Tyler Carson earned his BS in Physics from the University of Northern Colorado in 2009. He currently is a graduate student in the University of New Mexico Optical Science & Engineering program. Graduate work takes place at the Air Force Research Laboratory where he is involved in the development of solid-state lasers.

Phillip Peterson has over 60 refereed publications in areas such as parametric mixing, Raman scattering, Brillouin scattering, fiber lasers, and solid state lasers.

Tim Lucas received his M.S. degree in Electrical Engineering from New Mexico State University in 1990. His expertise is in optical design and laser resonators.

William P. Latham completed his PhD in physics at the University of North Texas in 1976. He is presently a senior research physicist at the Air Force Research Laboratories with 160 published papers and reports. He is a Fellow of the Optical Society of America, a Fellow of the SPIE, the International Society for Optical Engineering, a Fellow of the Laser Institute of America, and a Fellow of the Directed Energy Professional Society.

Huseyin Bostanci is a lead research engineer at RINI Technologies for Evaporative Spray Cooling (ESC) and miniature refrigeration technologies used to cool laser systems. He received his BS in Mechanical Engineering from Istanbul Technical University in 1998, MS in Nuclear Engineering from the University of New Mexico in 2001, and was awarded his PhD in Mechanical Engineering for his Thermal Fluids and ESC research from the University of Central Florida in 2010.

Jennifer J. Huddle-Lindauer conducts research in the areas of Evaporative Spray Cooling (ESC), Thermal Energy Storage (TES), and miniature refrigeration technologies at RINI Technologies. She attended the University of Central Florida where she received her BS in Aerospace Engineering in 1999 and MS in Mechanical Engineering, Thermal Fluids for her research in spray cooling laser diode arrays in 2000.

Benjamin A. Saarloos is the Director of Engineering for RINI Technologies and is responsible for the advancement of all technical development. Mr. Saarloos received his BS in Engineering from Dordt College in Sioux Center, Iowa, and his MS in Mechanical Engineering from the University of Illinois at Urbana-Champaign (UIUC), for his research related to solid propellant fuels with a special emphasis on the thermodynamic and heat transfer properties.

Dan Rini founded RINI Technologies in 2000 to develop advanced spray cooling and thermal energy storage technologies for cooling high-energy lasers. Dr. Rini attended the University of Central Florida where he received his BS in Aerospace Engineering in 1995, his MS in Mechanical Engineering in 1997, and his PhD in Mechanical Engineering—Thermal Fluids for his spray cooling research in 2000.

DISTRIBUTION LIST

DTIC/OCP 8725 John J. Kingman Rd, Suite 0944 Ft Belvoir, VA 22060-6218	1 cy
AFRL/RVIL Kirtland AFB, NM 87117-5776	1 cy
Timothy Newell Official Record Copy AFRL/RDLT	1 cy