



**NDIA**  
NATIONAL DEFENSE INDUSTRIAL ASSOCIATION



---

---

*Files are in Adobe Acrobat 3.0 format.*

---

---

**45th Annual Fuze Conference  
16-18 April 2001  
Table of Contents**

**Tuesday, April 17, 2001**

**SESSION II**

[A Viewpoint from OSD](#) by Anthony J. Melita, OUSD(AT&L)/S&TS,M

[Fuzing at Dahlgren](#) by Michael A. Till, NSWC, Dahlgren

[Naval Air Systems Command Fuzing Overview](#) by Steven E. Fowler, Naval Air Warfare Center

[Ordnance Fuzing/Safety & Arming Programs Overview](#) by Anh N. Duong, NAVSEA, Indian Head

[Fuzes for Air Force Unguided and Precision Guided Weapons](#) by Frank Robbins, Air Armament Center, Eglin AFB

[PEO Tactical Missiles Overview](#) by COL Jody Maxwell, PEO Tactical Missiles

[Army Perspective](#) by COL(P) Vincent Boles, U.S. Army Materiel Command

**SESSION III**

[The Evolving Fuze or When a Fuze is not just a Fuze](#) by COL Richard Hulmes, UK Defence Ordnance Safety Group

[The Reactive Bridge: A Novel Solid-State Low Energy Initiator](#) by Dr. Thomas A. Baginski, Auburn University and David Fahey, Quantic Industries

[Innovative Digital Proximity Fuze for 76/62 mm Gun \(Microwave, Programmable\)](#) by Antonio Carriero, Simmel Difesa, Italy

[Optronic Mortar Proximity Fuze PX581](#) by Peter Becker, Dr. Gerhard Nowicki, Dr. Ulrich Obbarius and Frank Kienzler, Junghans Feinwerktechnik

[A Modular Approach to Electronic Fuze Development](#) by Mike Tucker, Fuchs Electronics, South Africa

[Storage Reliability of Reserve Batteries](#) by Jeff Swank and Allan Goldberg, Army Research Laboratory

[Miniature Thermal Batteries for Low-Current Applications](#) by Frank C. Krieger, Army Research Laboratory

[Common Precision Munitions Safety & Arming Device](#) by Richard Dirks, KDI Precision Products, Inc.

[FMU-160B: 105mm Proximity Fuze for the AC130 Gunship](#) by Bob Hertlein, Dave Lawson, KDI Precision Products, Inc. and Telly Manolatos, Electronics Development Corp.

**Wednesday, April 18, 2001**

#### **SESSION IV-A**

[Design and Development of a new Electronic Time \(ET\) Fuze for Mortars](#) by Anthony Pergolizzi and Dennis Ward, TACOM-ARDEC Fuze Division

[Electronic Design for XM784/XM785 Mortar Time Fuze](#) by Tom Walker and Andy Leschyshyn, TACOM

[JAMI Flight Termination System: A Cooperative Development Between NAWC/CL and KAMAN](#) by Dale Spencer and Andy Yuenger, Kaman Aerospace

[Design Methodology for Safe & Arm Devices](#) by Friedrich Sauerlander, Naval Air Warfare Center

[New Development in Sensitivity Testing](#) by Dr. Barry T. Neyer, PerkinElmer Optoelectronics

[Air Bursting Munition ABM Medium Calibre Applications](#) by Allan Buckley and Pierre Freymond, Oerlikon Contrayes Pyrotec AG

[Spin Rate Sensor for Fuzing Applications, Theory and Test Results](#) by Dale Spencer, Kaman Aerospace

#### **SESSION V-A**

[Guided MLRS USA and Foreign Partners](#) by Ted Lewis and Thomas Nickolin, KDI Precision Products, Inc.

[Low Cost, Shock Hardened Recorder](#) by Gabriel Soto, Naval Air Warfare Center

[MK432 Electronic Time Fuze - A New Fuze for the US Navy](#) by Chad Finch, Naval Surface Warfare Center and Dave Mengel, Bulova Technologies, L.L.C.

[Fuze for Global Interoperability](#) by Brad Biggs, Alliant Techsystems

[Precision CMOS Clock Oscillator for HI-G Applications](#) by Fred Mirow, Micro Oscillator, Inc. and Dick Mabry, Air Force Research Laboratory

[GIF Guidance Integrated Fuze](#) by Keith Lewis, Harold Wendt and Mark Engel, Naval Surface Warfare Center

[Mitigation of FMU-139 Component Obsolescence](#) by John N. Minnich and Ted Lewis, KDI Precision Products, Inc.

[Mechanical Packaging of the EX 433 Proximity Fuze for Submunitions](#) by Eugene Marquis, Naval Surface Warfare Center



# Low Cost, Shock Hardened Recorder

Gabriel Soto

Fuze Development Branch

China Lake, CA 93555

SotoGH@navair.navy.mil

760-939-7775

Approved for public release; distribution is unlimited

# Overview

- Low cost data recorder with non-volatile memory, capable of operation through high shock environments
- User configurable input modes
- Simple serial data interface for downloading stored data

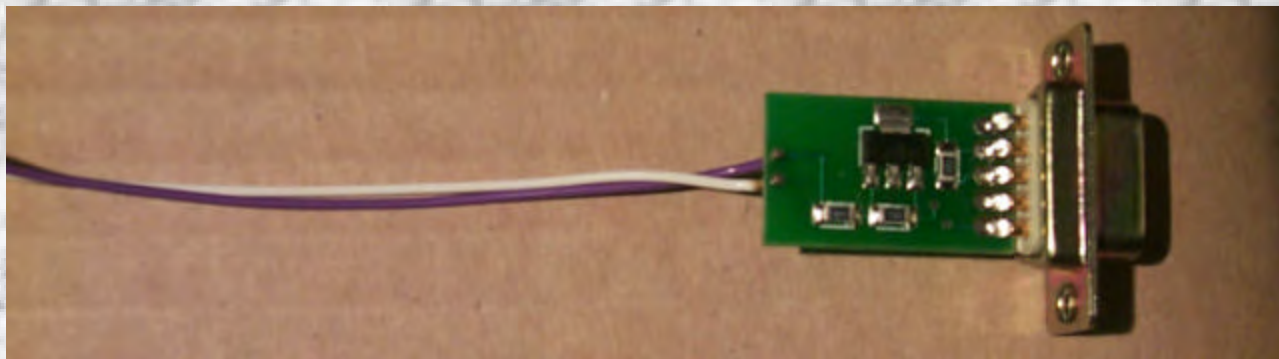

# Features & Benefits

- Non-Volatile Memory
  - 100 Year Data Retention Over Industrial Temperature Range (-55 to +150 storage, -40 to +85 operational)
  - Auto Recall During Power Up
  - Auto Store During Power Down
  - SRAM and EEPROM
  - 16 x 32k data storage

# Features & Benefits

- Configurable
  - Single 16-bit Analog Channel
  - Single 12-bit Analog Channel and 4 Digital Channels
  - Single 8-bit Analog Channel and 8 Digital Channels
  - Jumper Selectable Sample Rate

# Features & Benefits

- Easy to use 5-Wire Interface
  - RS-232 Serial Connection for Download
  - Wide Input Supply Voltage (7 to 35 Volts)
  - Single Wire for Trigger/Mode Input
  - Data Stored in Spreadsheet Format by Reader Software

# Features & Benefits

- Alternative Configurations
  - Expanded Memory Version (4x)
  - Low Voltage Version (2 to 9 Volts)
  - On-Board Signal Conditioning Version
    - Differential Input
    - Programmable Gain Stage
    - Low Pass Filter ( $f_c = 1/10$  Sample Rate)
  - Serial Data Capture Version

# Applications

- Parachute Drop Testing
  - Low Cost
  - Compact and Light Weight
  - Simple

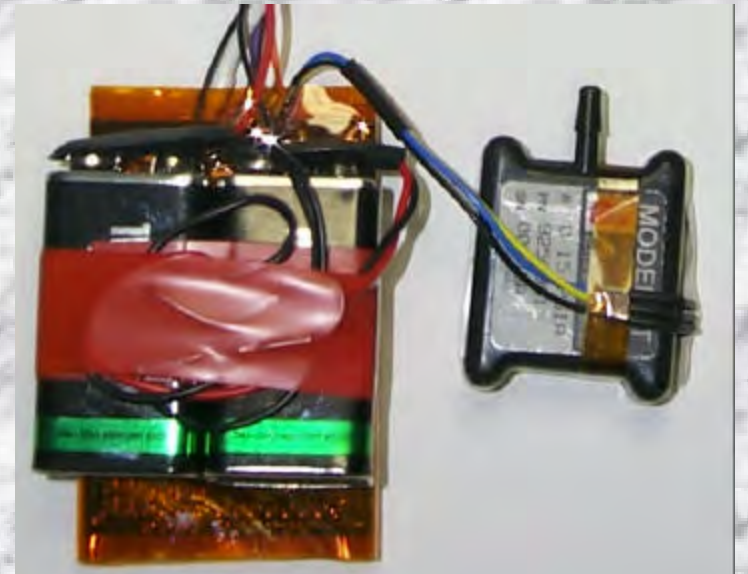
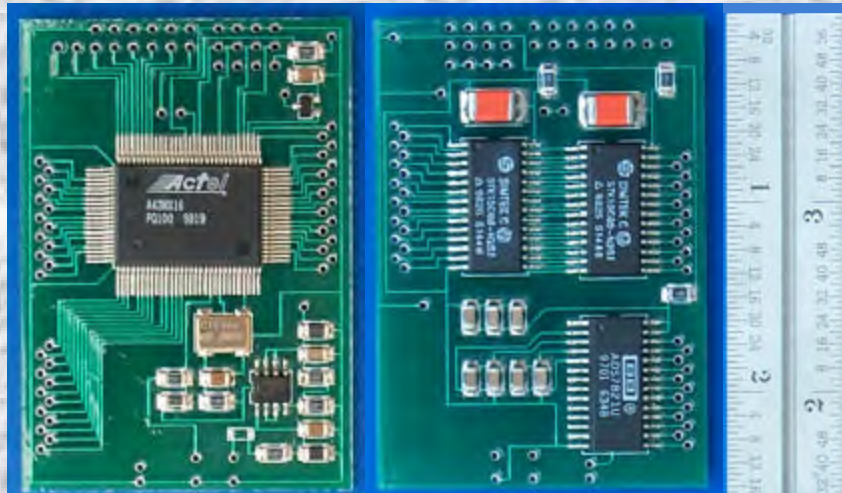

# Applications

## ■ Drop Test Data



# Applications

## ■ Air Gun Test

- Shot into honeycomb aluminum
- Velocity: approximately 150 ft/sec
- Diameter of ball: ~ 6 inches



# Applications

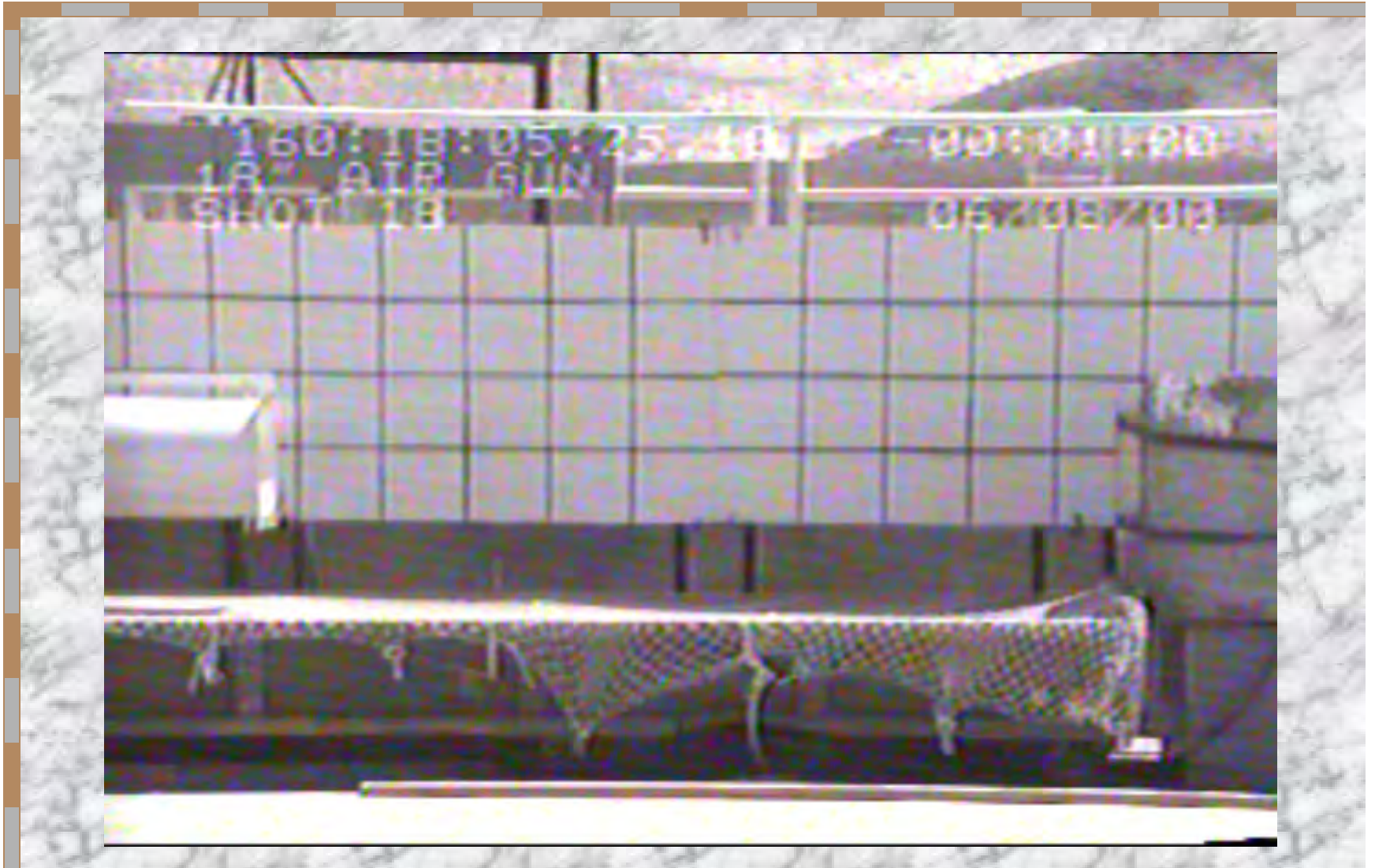

# Applications

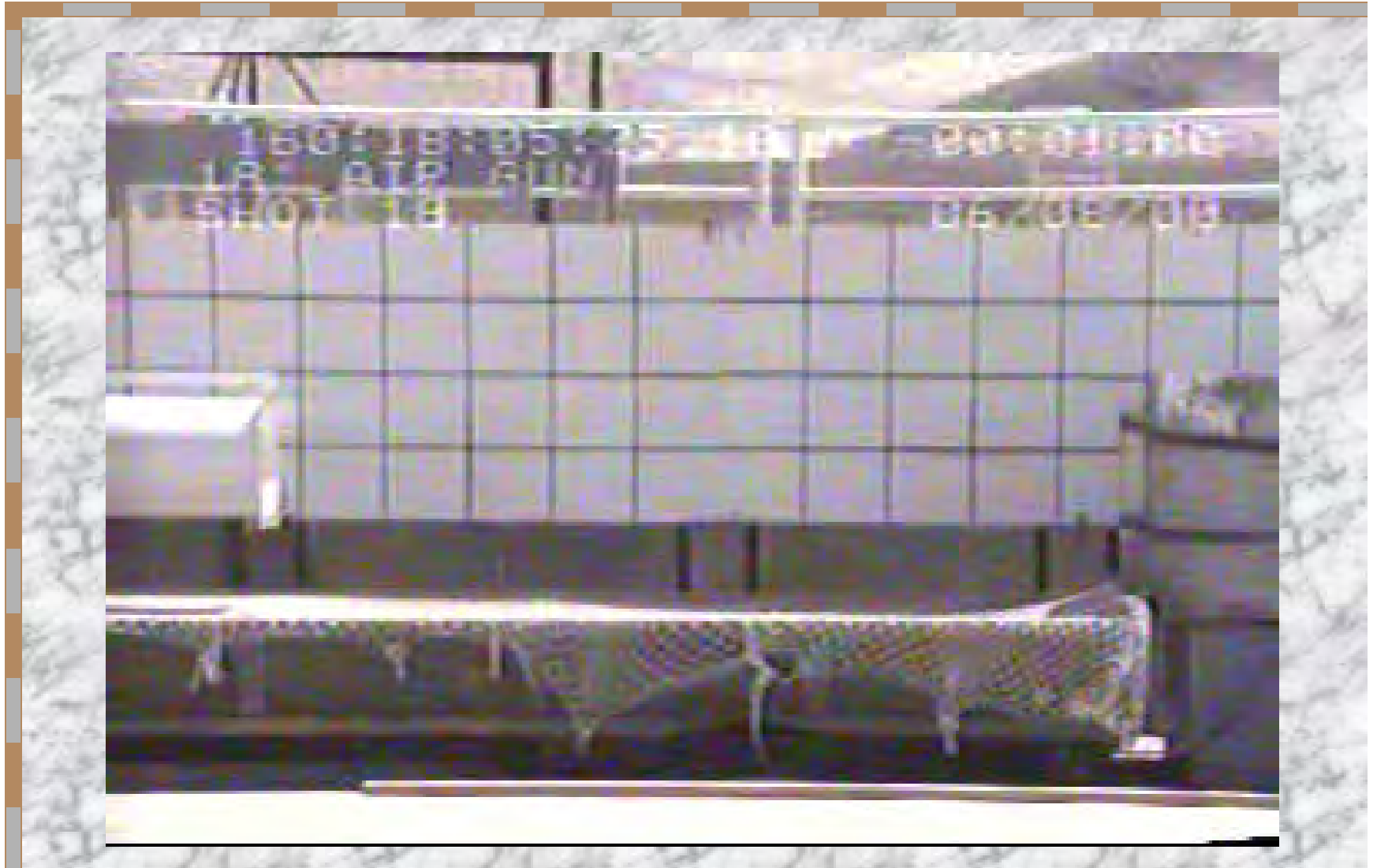

# Applications

## ■ Air Gun Test Data

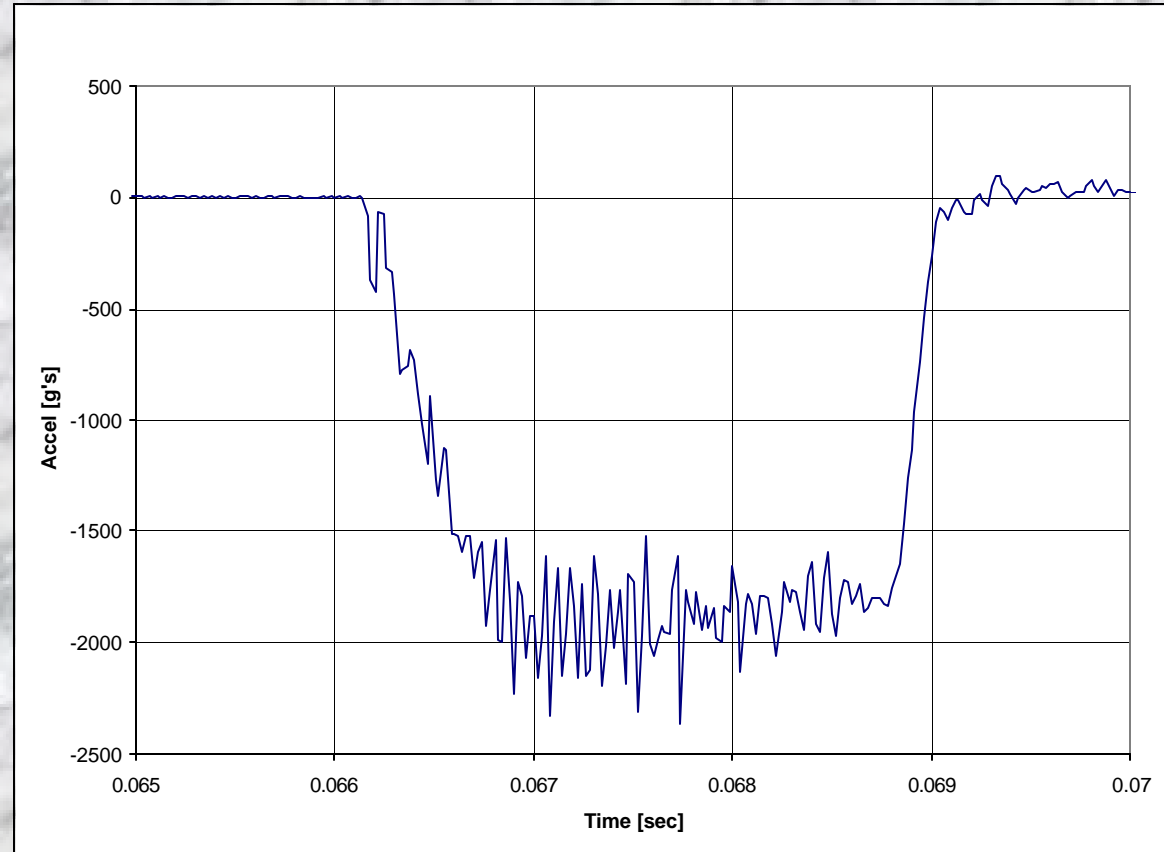

# Applications

- Penetration Testing
  - Scaled Model
  - Super-Sonic
  - Multiple Media



# Specifications

- Memory: 16 x 32k, Non-Volatile.
- Sample Rate: 100k, 10k, 1k, 100 samples per second
- Record Time: 0.328 s, 3.28 s, 32.8 s, 5.44 min
- Input Signal Voltage: 0 to 5 V
- Current Draw: 500  $\mu$ A (sleep)/ 60 mA (active)
- Data Sheet Available Upon Request

# Parts Cost

- Parts cost is \$200 to \$250 per unit in small quantities.
  - Analog to Digital Converter - \$35
  - Field Programmable Gate Array - \$30
  - Non-Volatile Memory - \$30
  - Printed Circuit Boards - \$25
  - Oscillator - \$8 to \$15

# Future Plans

- Smaller Size
- Lower Power

- ASIC Version

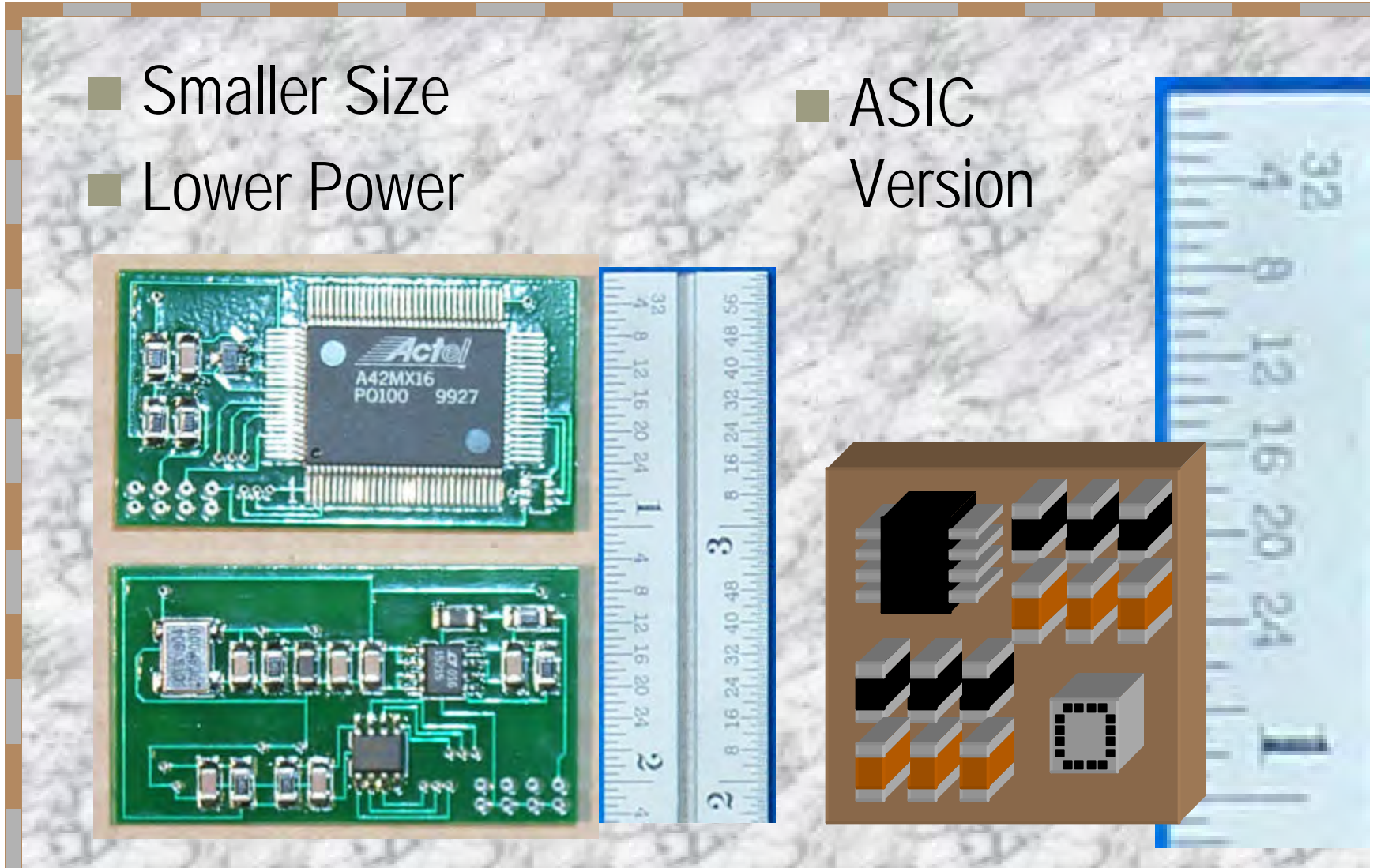

# Summary

- Survives Shock of Penetration
- Easy to Use Interface
- Low Cost
- Versatile
- Simple

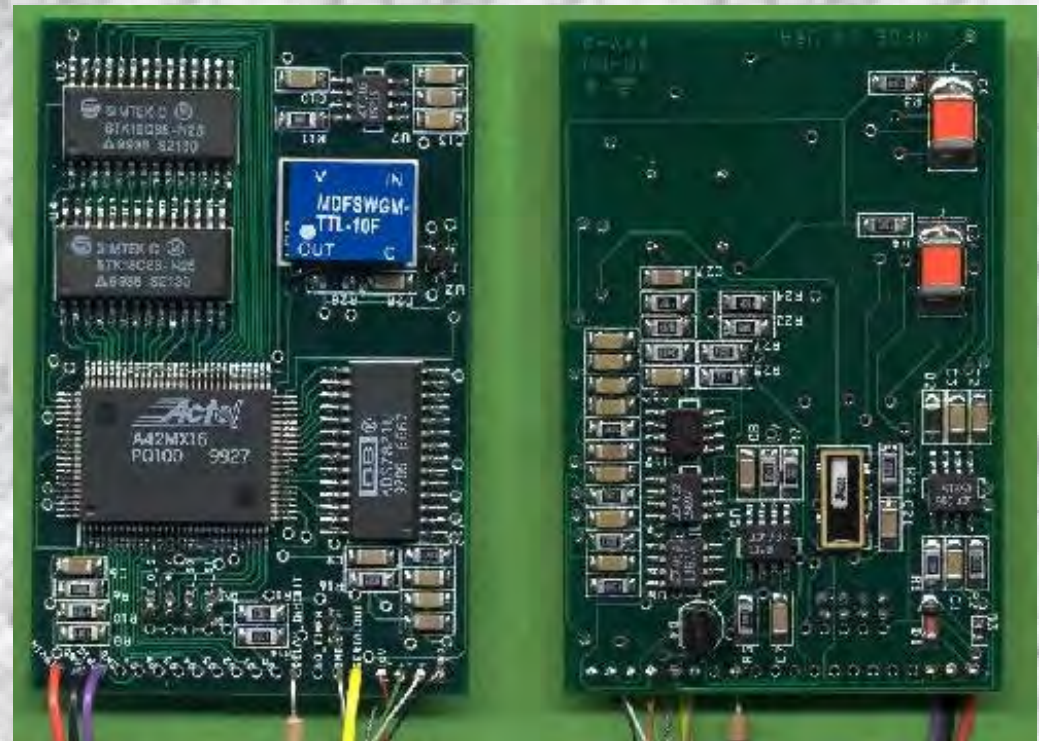

# Precision CMOS Clock Oscillator for HI-G Applications

Presented by  
Fred Mirow  
Chief Engineer  
Micro Oscillator,  
Inc.

Co Author  
Dick Mabry  
AFRL/MNMF  
Eglin AFB

***WEB SITE:***

***MICRO-OSCILLATOR.COM***

# Summary of Discussion

- ◆ MOI-1000 CLOCK OSCILLATOR
- ◆ COMPARISON OF OSCILLATOR TYPES
- ◆ SBIR AF98-220
- ◆ MOI-2000 CLOCK OSCILLATOR
- ◆ Proposed 32.7KHZ Oscillator
- ◆ Summary & Recap

# MOI-1000 Clock Oscillator

- *Smallest*
- *Fastest Turn On*
- *Most Rugged*
- *Lowest Power*



# OSCILLATOR CIRCUIT

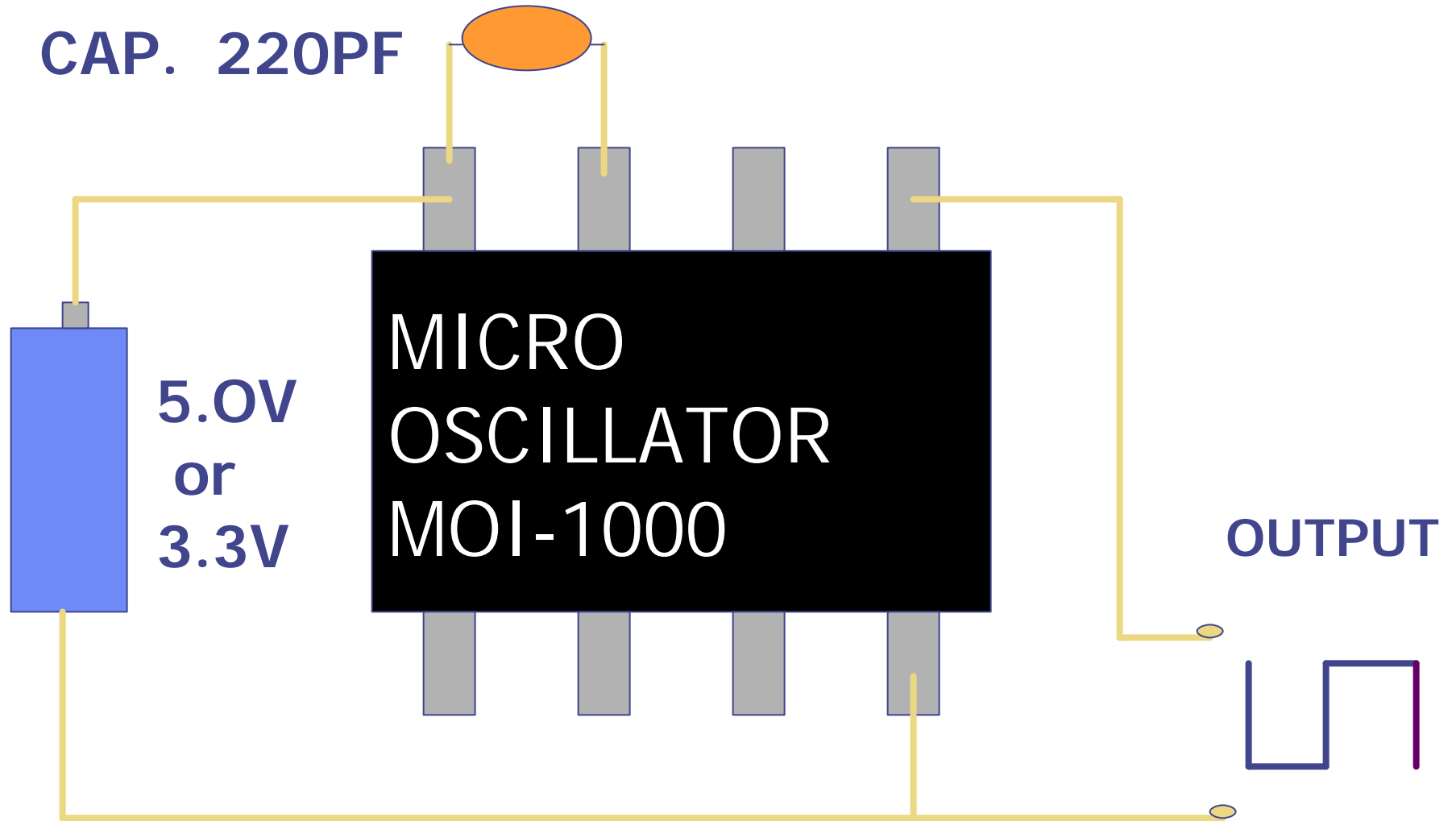

# MOI-1000 SPECIFICATION

## CMOS IC

SIZE	1.7 X .9 MM
FREQUENCY	16, 20, 24 MHz
FREQUENCY ACCURACY (Temp. & Voltage, Etc.)	
INDUSTRIAL TEMP	0.5%
MILITARY TEMP	1.0%
OPERATING POWER	(5.0V) 25 mW (3.3V) 10 mW
OUTPUT, SQUARE WAVE SYMMETRY	55/45%
SHOCK, OPERATIONAL	> 80,000 G
PACKAGE	SO-8, MSO-8 or Bare Die

# MOI-1000 ACCELERATION TEST (UNIT OPERATING)

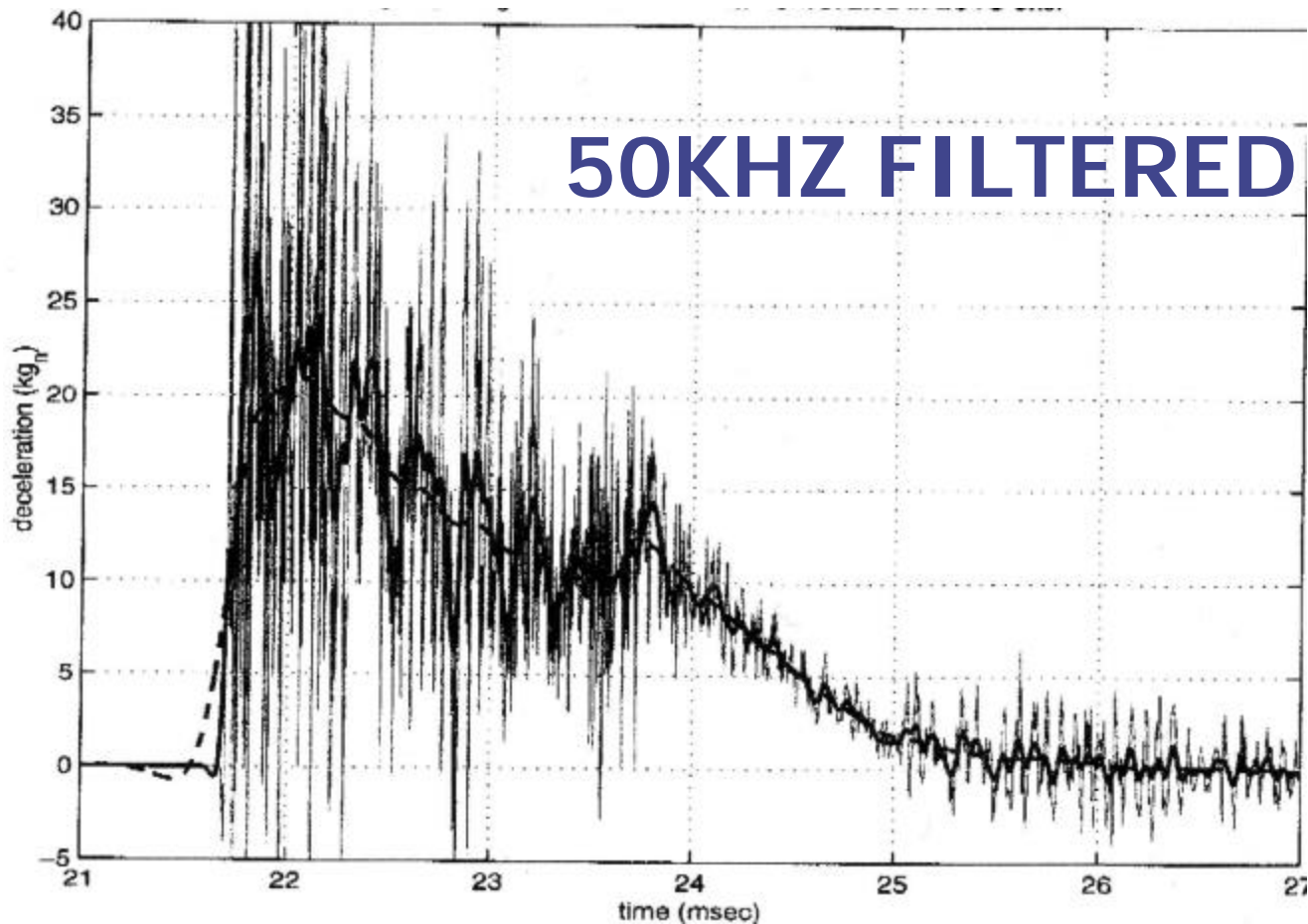

**155 MM HOWITZER, CONCRETE WALL**  
**PLOT CURTESY OF AFRL/MNMF**

# MOI-1000 ACCELERATION TEST (UNIT OPERATING)

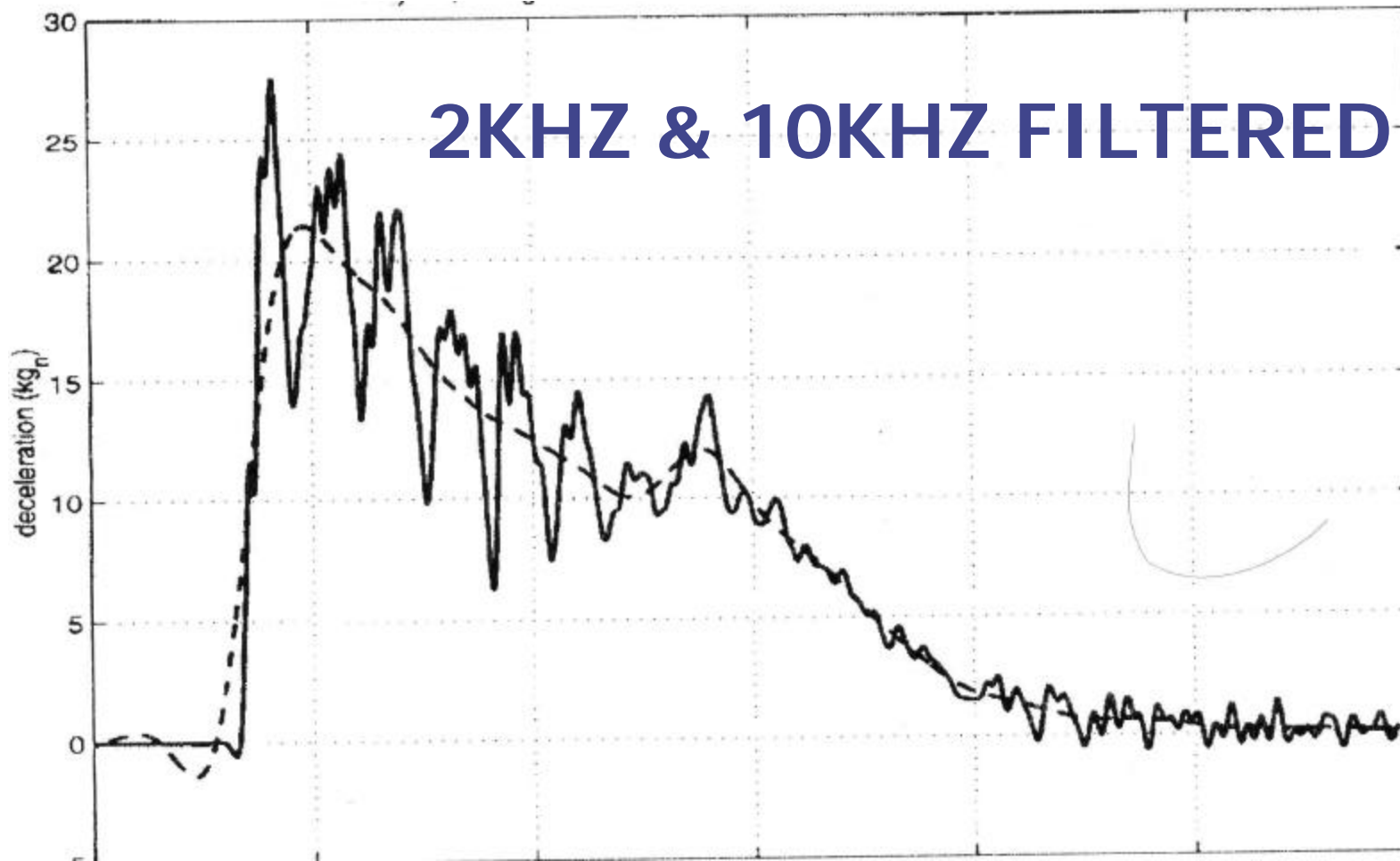

**155 MM HOWITZER, CONCRETE WALL  
PLOT CURTESY OF AFRL/MNMF**

# MOI-1000 CLOCK OSCILLATOR SYSTEM BLOCK DIAGRAM

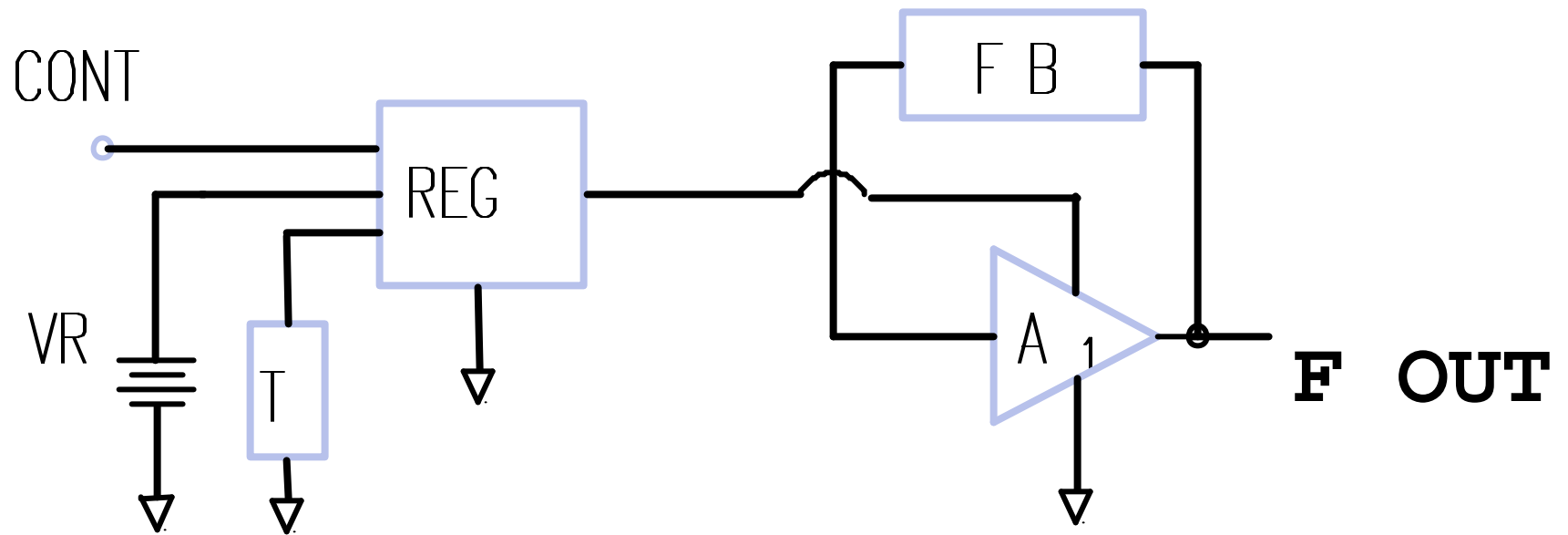

# PROPAGATION DELAY TIME VARIATIONS

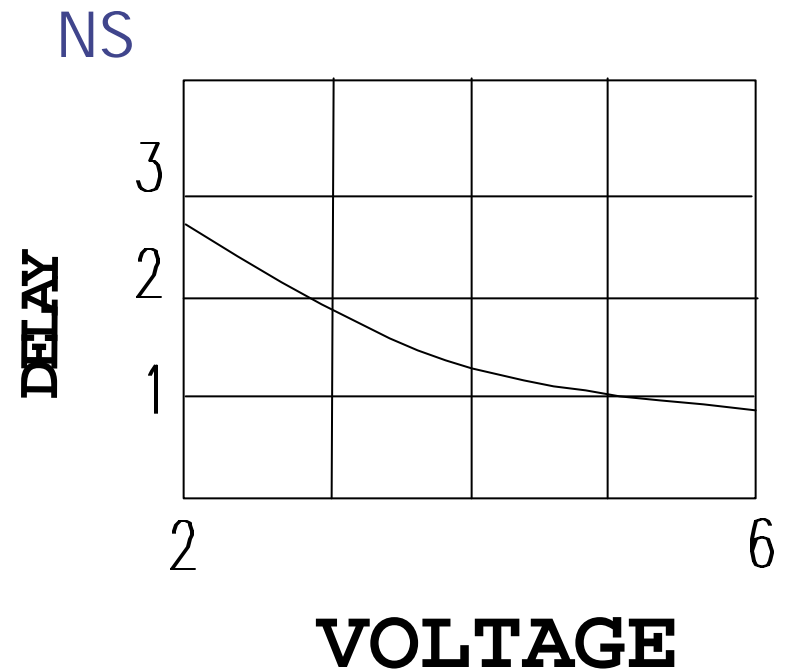
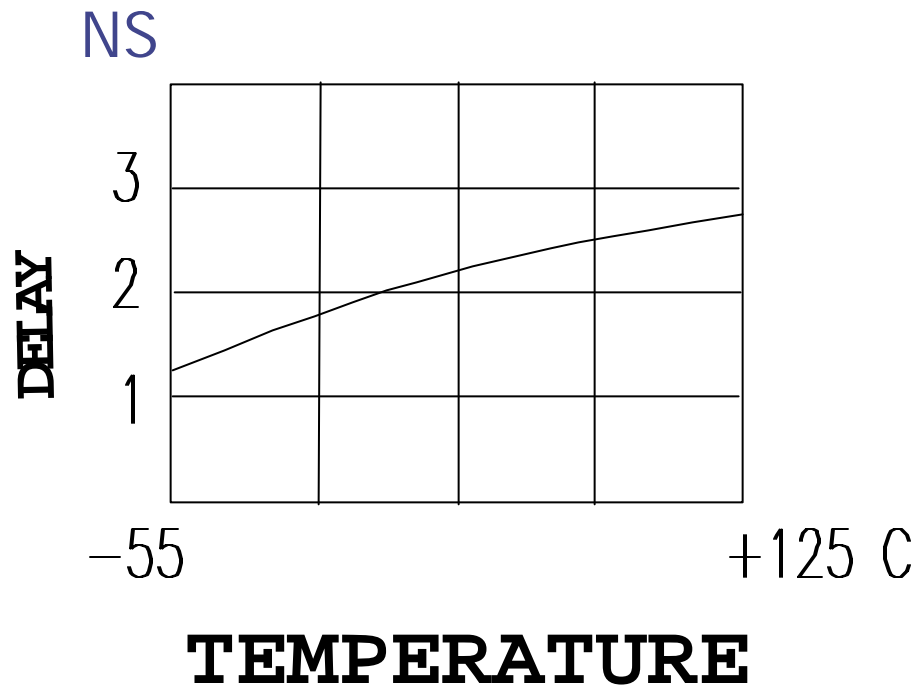

# CLOCK OSCILLATOR COMPARISON CHART

	MICRO OSCILLATOR	CRYSTAL CLOCK	CERAMIC RESONATOR
FREQ. TOL.	MEDIUM	HIGH	MEDIUM
SIZE (mm)	.9 x 1.7	5 x 7	2.8 x 6.5
HYBRID	YES	NO	NO
RUGGEDNESS	VERY HIGH	LOW	MEDIUM

## MOI-1000 ADVANTAGES

- 1: COMPLETE CLOCK OSCILLATOR
- 2: SMALL SIZE, BARE DIE OR S0-8
- 3: NO START UP PROBLEMS
- 4: NO FREQUENCY JUMPING
- 5: 3.3 V OR 5.0 V AVAILABLE
- 6: +/- 0.5% TOLERANCE INDUSTRIAL
- 7: +/- 1.0% TOLERANCE MILITARY

## MOI-1000 DISADVANTAGES

- 1: NOT AS ACCURATE AS CRYSTAL

# EXISTING APPLICATIONS

## **PROGRAMMABLE PROJECTILE FUZE**

CRITICAL REQUIREMENTS MET-

OPERATIONAL IN HIGH G ENVIRONMENT

FAST TURN ON TIME

BARE DIE FOR HYBRID PACKAGING

LOW OPERATING POWER

## **HARD TARGET FUZING**

CRITICAL REQUIREMENTS MET-

OPERATIONAL IN HIGH G ENVIRONMENT

LOW OPERATING POWER

# SBIR AF98-220

## PURPOSES:

### 1) IMPROVE MOI-1000:

REDUCED OPERATING POWER  
WIDER FREQUENCY RANGE

### 2) DEVELOP 32.7KHZ VERSION

# SBIR TIMER BASE SYSTEM SPECIFICATION

	<b>SYSTEM 1</b>	<b>SYSTEM 2</b>
VOLTAGE	5V +/-5%	3.3V +/-5%
CURRENT	1 MA MAX	1 MA MAX
FREQ. TOL.	+/-1% ABSOLUTE	+/-1% ABSOLUTE
FREQ. RANGE SINGLE FREQ.	14.0 TO 20.0 MHZ	3.5 TO 5.0 MHZ
OPERATING TEMP.	-55 TO 125 °C	-55 TO 125 °C
OUTPUT DRIVE	2 HC CMOS	2 HC CMOS

# MOI-2000 CLOCK OSCILLATOR SYSTEM BLOCK DIAGRAM

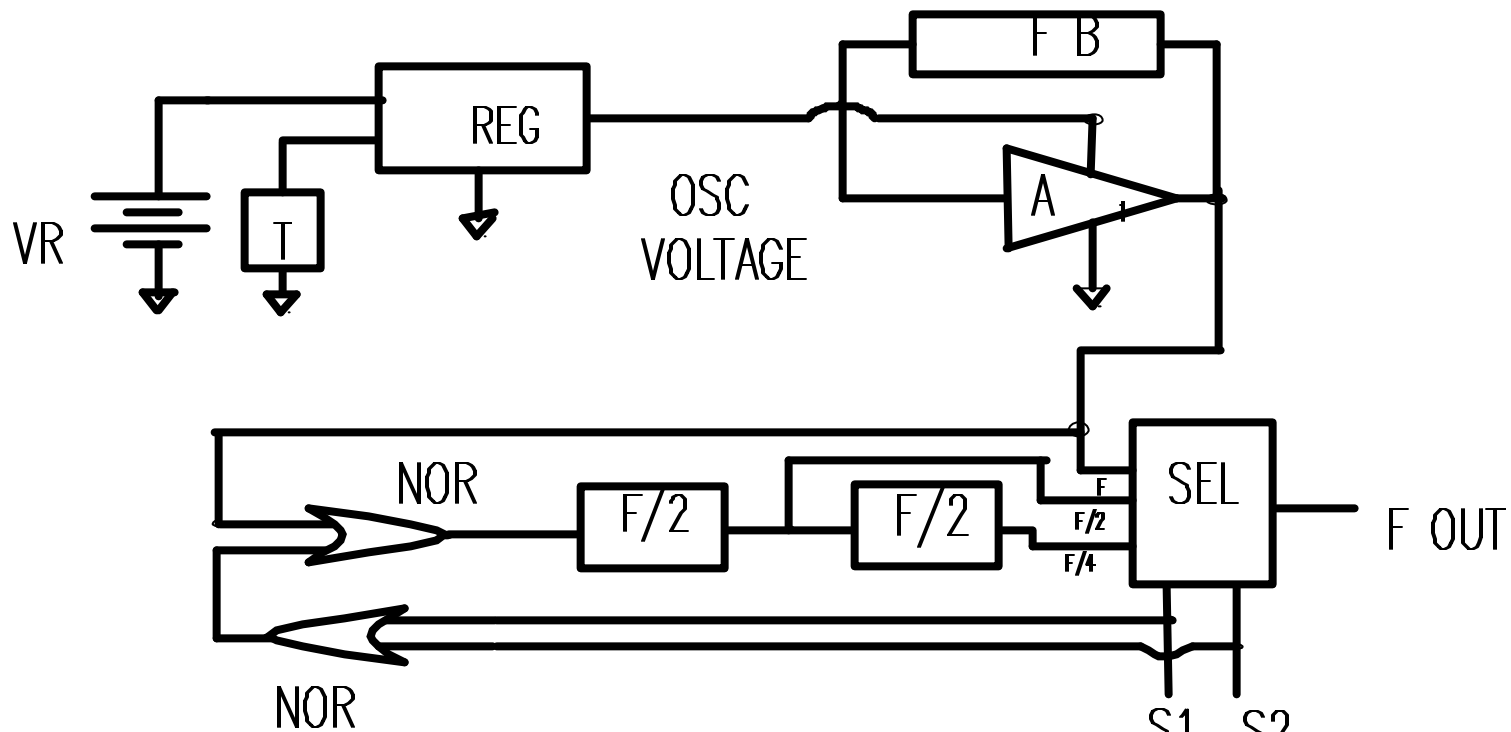

S1	S2	F OUT
0	0	F
1	0	F/2
0	1	F/4

COMPARISON  
OF  
MOI-1000 TO MOI-2000

MOI-1000

MOI-2000

FREQ.

14 to 24MHz

4 to 20 MHz

CURRENT

5.0 VOLTS

5mA

1.6mA

3.3 VOLTS

3mA

1ma

TOL.

+/-1%

+/-1%

# MOI-2000 PREPRODUCTION MEASURED PERFORMANCE

VOLTAGE	5	3.3
CURRENT	2.2 Ma	1.4 Ma
FREQUENCY	16 MHz	10 MHz
FREQ. TOL. -55 - 125°C	± 1.0%	± 1%

# MOI-2000 OSCILLATOR OUTPUT 3.3V 12PF LOAD, 53/47% DUTY CYCLE

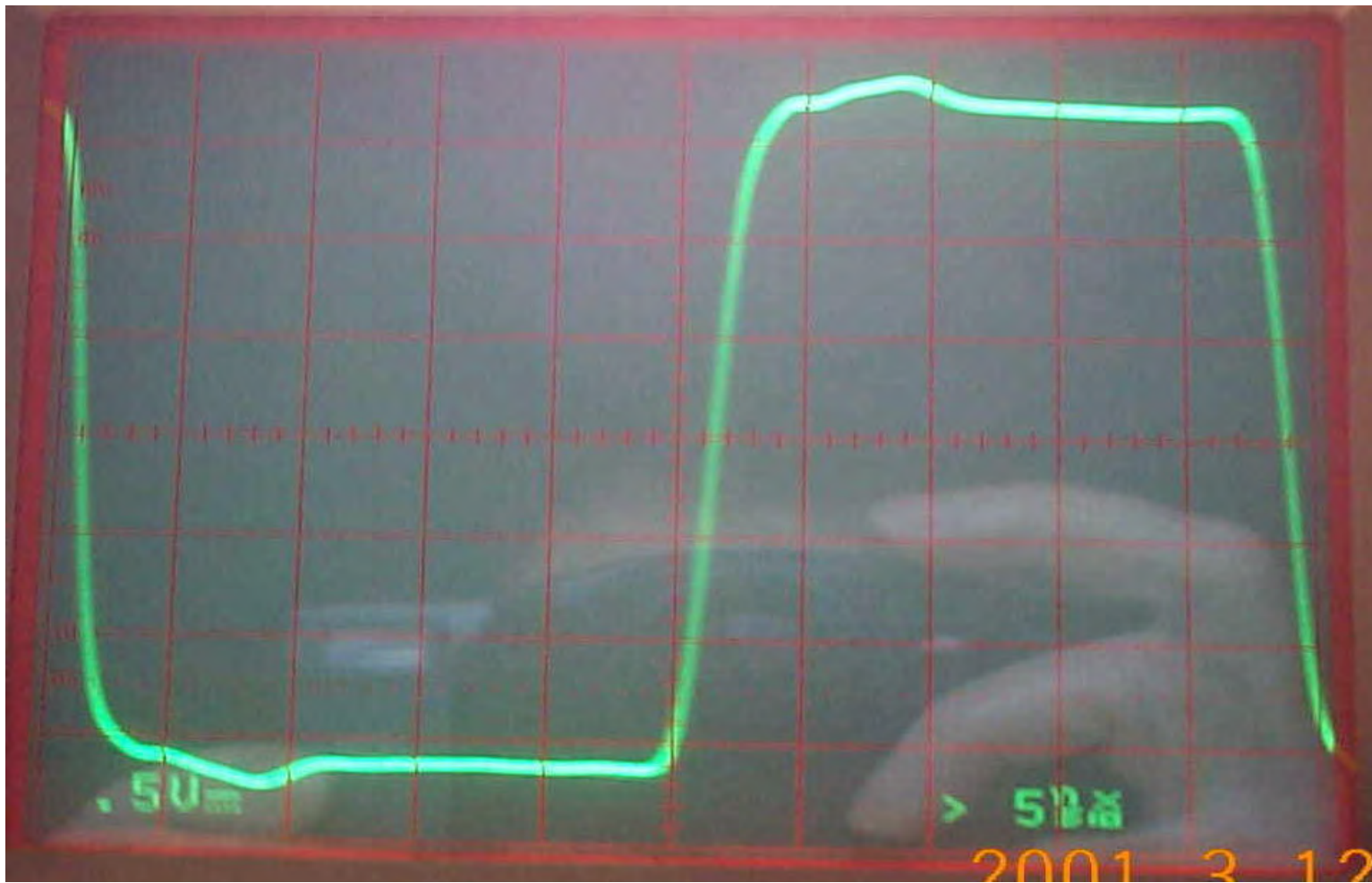

MOI-2000 OSCILLATOR OUTPUT  
3.3V 12PF LOAD, 2 NSEC/DIV

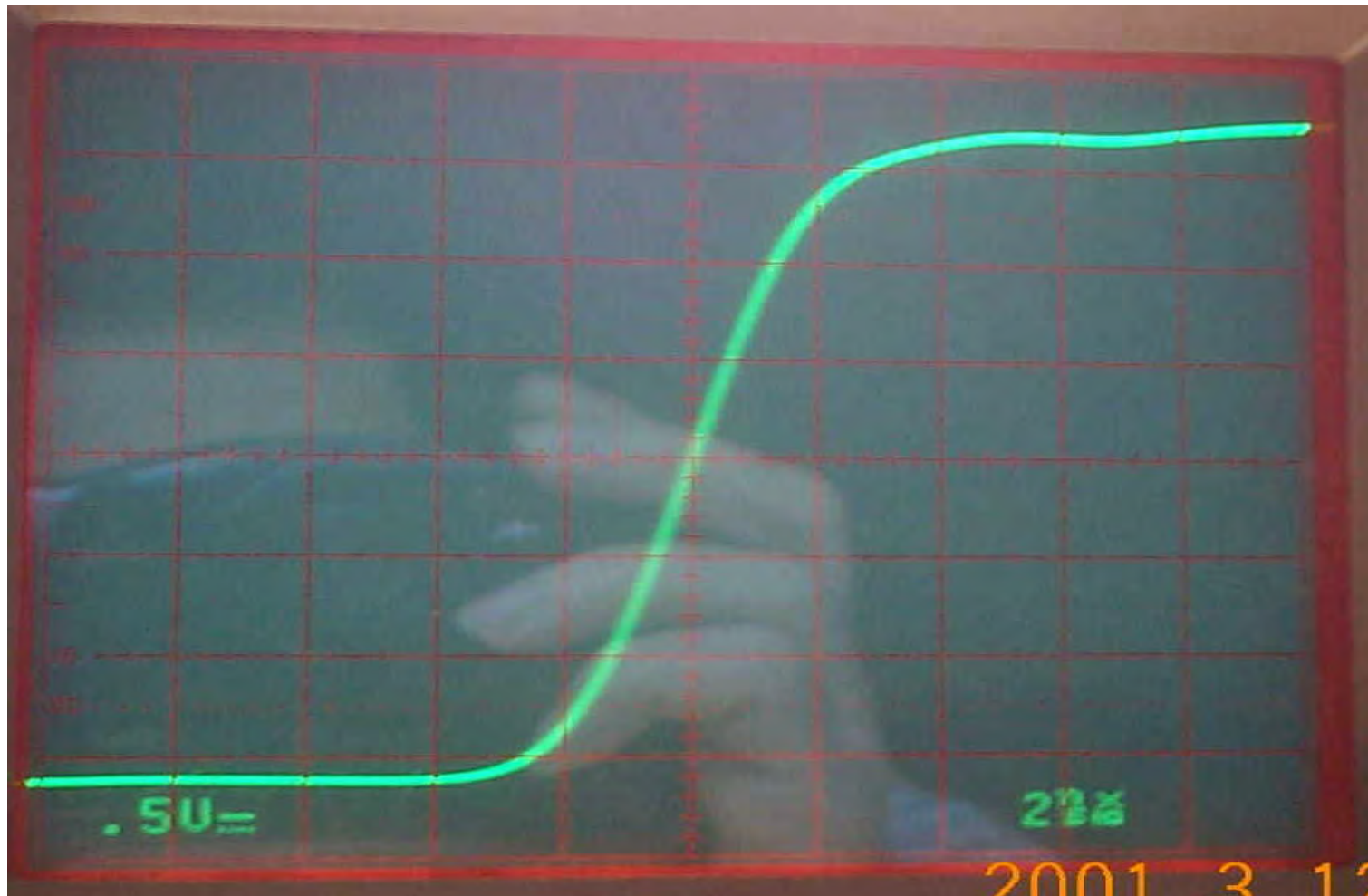

# MOI-2000 OSCILLATOR OUTPUT DELAYED 3.3V 12PF LOAD

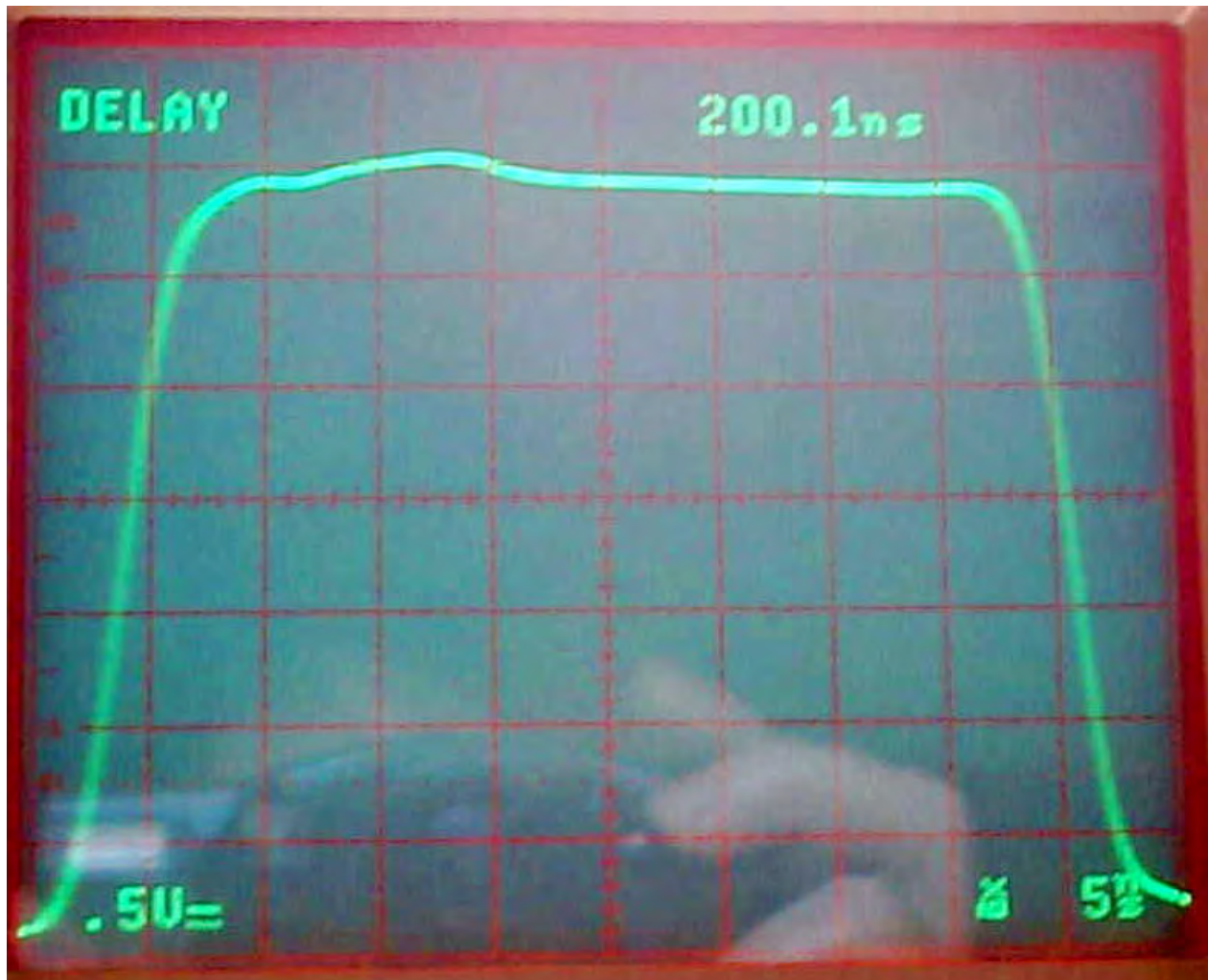

# 32.7 KHz TIME BASE SYSTEM SBIR SPECIFICATION

Operating Voltage	3.3v or 5V 5%
Operating Current	0.2 ma max
Frequency Tol.	+/- 1%
Frequency	32.7 KHz
Operating Temp.	-55 to 125 c
Package	S0-8

# OSCILLATOR AVAILABILITY SCHEDULE

**MOI-2000**

**5V**

**JULY 2001**

**3.3V**

**NOW**

**32 .7KHz**

**JULY 2002**

# Summary & Recap

## MOI-1000

5 YEARS OF PROVEN  
PERFORMANCE IN  
HI-G APPLICATIONS

## MOI-2000

SAME PROVEN TECHNOLOGY AS  
MOI-1000 AT A MUCH LOWER  
OPERATING POWER LEVEL



# TEAM FUZING

---

**SEI**

**DAYRON**

**KDI**

**RAYMOND**

[www.teamfuzing.com](http://www.teamfuzing.com)



# TEAM FUZING

## Programme Objectives

- Obsolescence
- Tooling
- Test Gear
- Safety
- Reliability
- Qualification
- 1<sup>st</sup> Article
- Production



SEI

DAYRON

KDI

RAYMOND





# TEAM FUZING

## Qualification Programme

### Sub System Tests

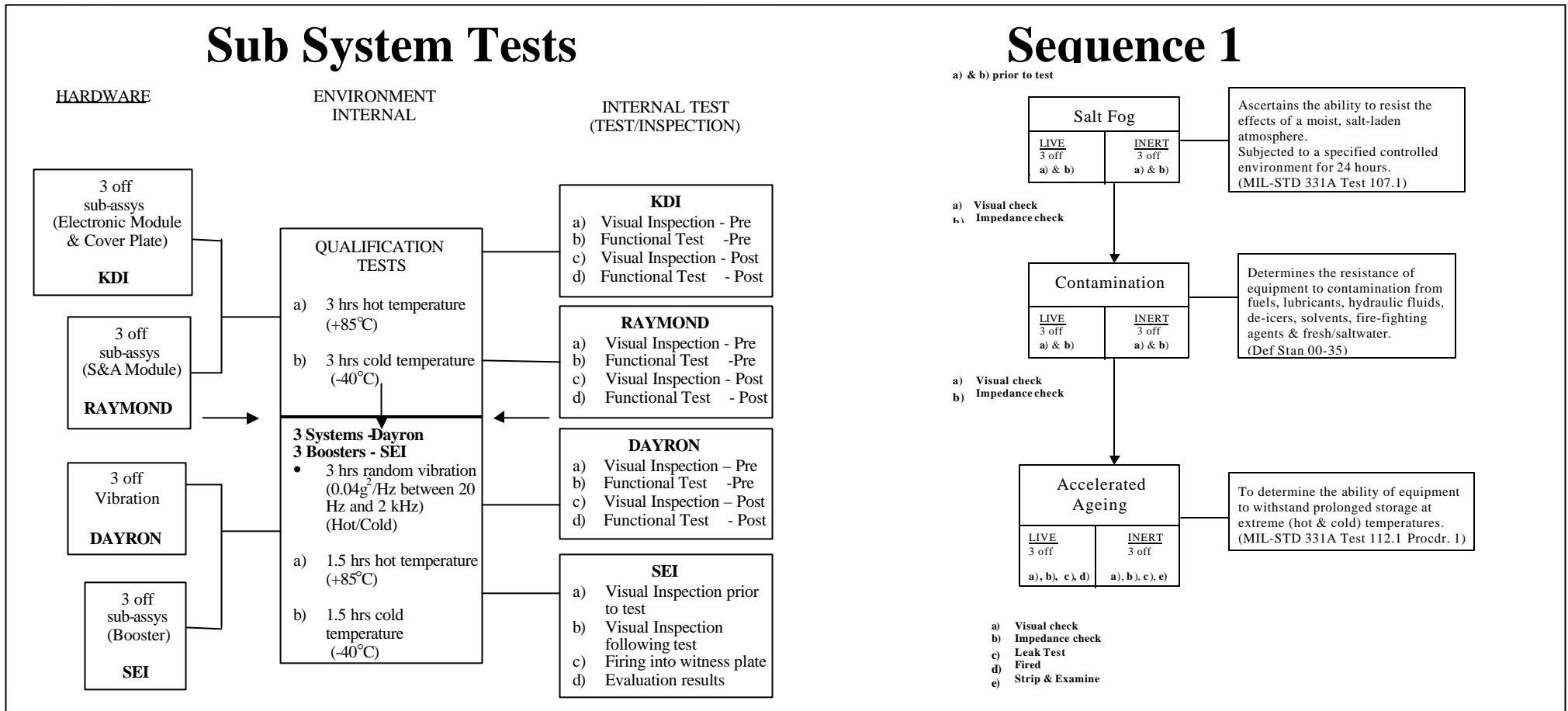

SEI

DAYRON

KDI

RAYMOND





# TEAM FUZING

## FMU-139B/B

- Further contract for 3000 FMU139B/B fuzes for a European country.
- Need to address the Power consumption issue to meet the FFCS requirement for the Navy.
- Potential further orders for other European and Middle/Far East Countries.



SEI

DAYRON

KDI

RAYMOND





# TEAM FUZING

FMU-139 B/B



SEI

DAYRON

KDI

RAYMOND



# Mitigation of FMU-139 Component Obsolescence

John N. Minnich, KDI Electrical Engineer

Ted Lewis, KDI Sr. Staff Engineer



SEI

DAYRON

KDI

RAYMOND



# FMU-139 Chronology

- FMU-139A/B
  - Full scale procurement commenced in 1985
  - Last procurement was in 1993
- SAU - A FMU-139A/B derivative
  - Original build circa 1989-1992
  - Team Fuzing awarded contract in 1999, delivered units in 2000.



SEI

DAYRON

KDI

RAYMOND



# Two Major Design Challenges

- Replacing the obsolete 4-bit microcontroller.
  - Reverse engineering the logic without source code.
- Improving the operating duration when powered in FFCS mode.



SEI

DAYRON

KDI

RAYMOND



# Replacing the Microcontroller

- FMU-139 A/B based upon COP320C
  - 4 bit, CMOS design
  - Industrial temp range (-40 °C to 85 °C )
  - Low current: 100  $\mu$ A at 5V with  $f_{clk} = 32$  KHz
- KDI evaluated 8-bit  $\mu$ controllers and FPGAs
  - Architecture A: 8-bit  $\mu$ controller + ASIC
  - Architecture B: Two FPGAs / ASICs



SEI

DAYRON

KDI

RAYMOND



# Reverse engineering the fuze logic.

- Drawing package did not include source code.
  - ROM Object code available as printed media only !
- KDI attempted to reverse assemble this ROM
  - Output is uncommented assembly code.
  - Output appeared to have reverse assembly errors.
- KDI abandoned the  $\mu$ controller approach due to these issues.



SEI

DAYRON

KDI

RAYMOND



# What legacy documentation was available to KDI?

- FMU-139A/B Mil. spec. MIL-F-85815A(AS)
  - FFCS and Turbine operating modes
  - High & low drag arm times
  - Impact or proximity detection requirements
  - Impact or Prox function delay timing
- Navy DWG package 1379ASxxx
- SAU DWG package SK105xxxx



SEI

DAYRON

KDI

RAYMOND



# What information was missing ?

- Drawing package did not include source code.
  - Internal self tests
  - Detailed DUD logic requirements
  - Digital filtering / signal conditioning of inputs

To address these “holes” KDI requested a Commercial Service Agreement with the Navy



SEI

DAYRON

KDI

RAYMOND



# SAU Implementation

- 2 FPGAs replace the  $\mu$ controller and ASIC
  - FPGA, U<sub>402</sub> initiates Gag rod and DET circuitry
  - FPGA, U<sub>401</sub> initiates Bellows circuitry
- Switching regulator based on FMU-139 A/B  
“JANTX” implementation rather than SAU
- Components are predominantly “through-hole”



SEI

DAYRON

KDI

RAYMOND



# FPGA Partitioning

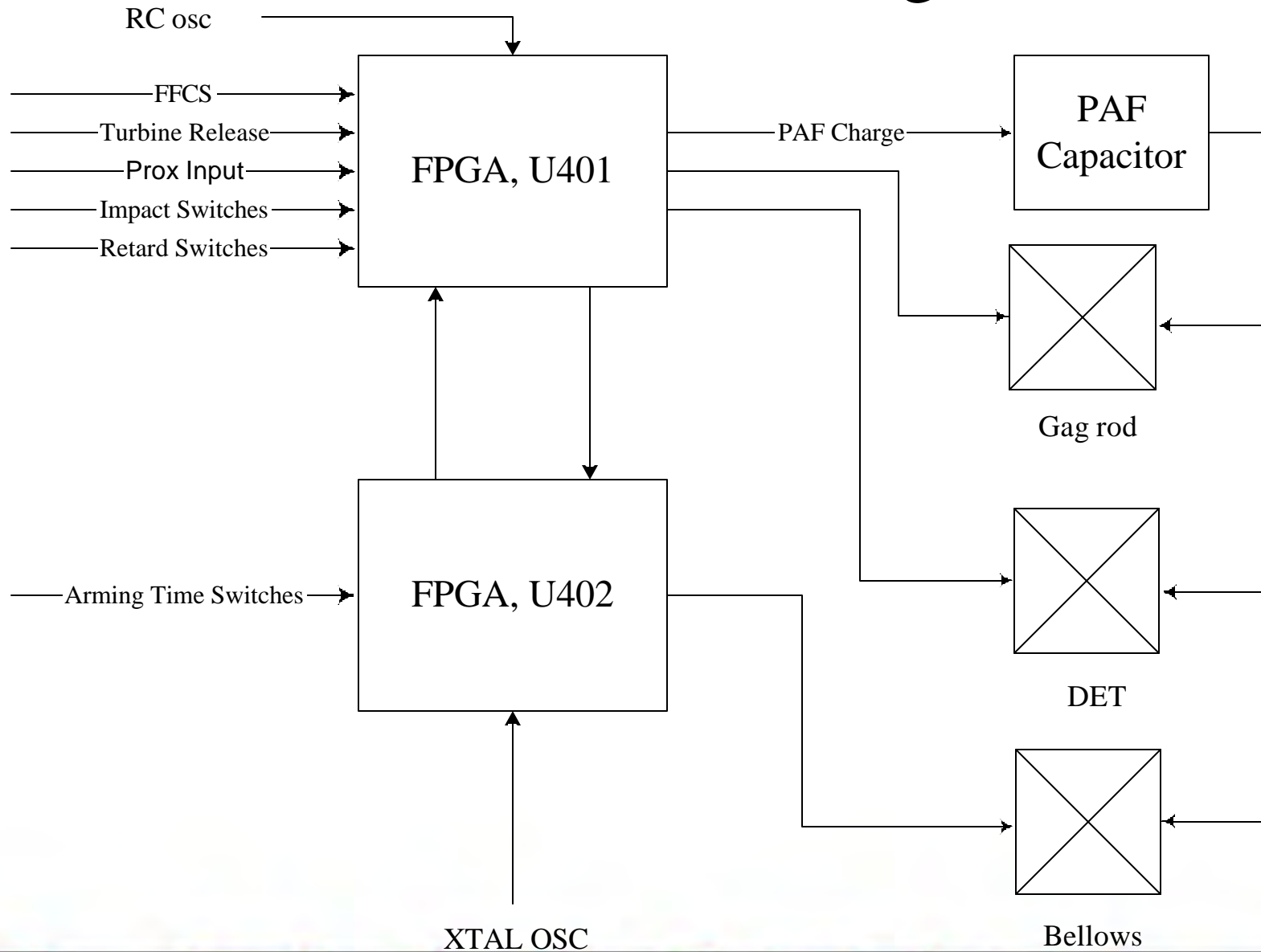

SEI

DAYRON

KDI

RAYMOND



# SAU Production Panel

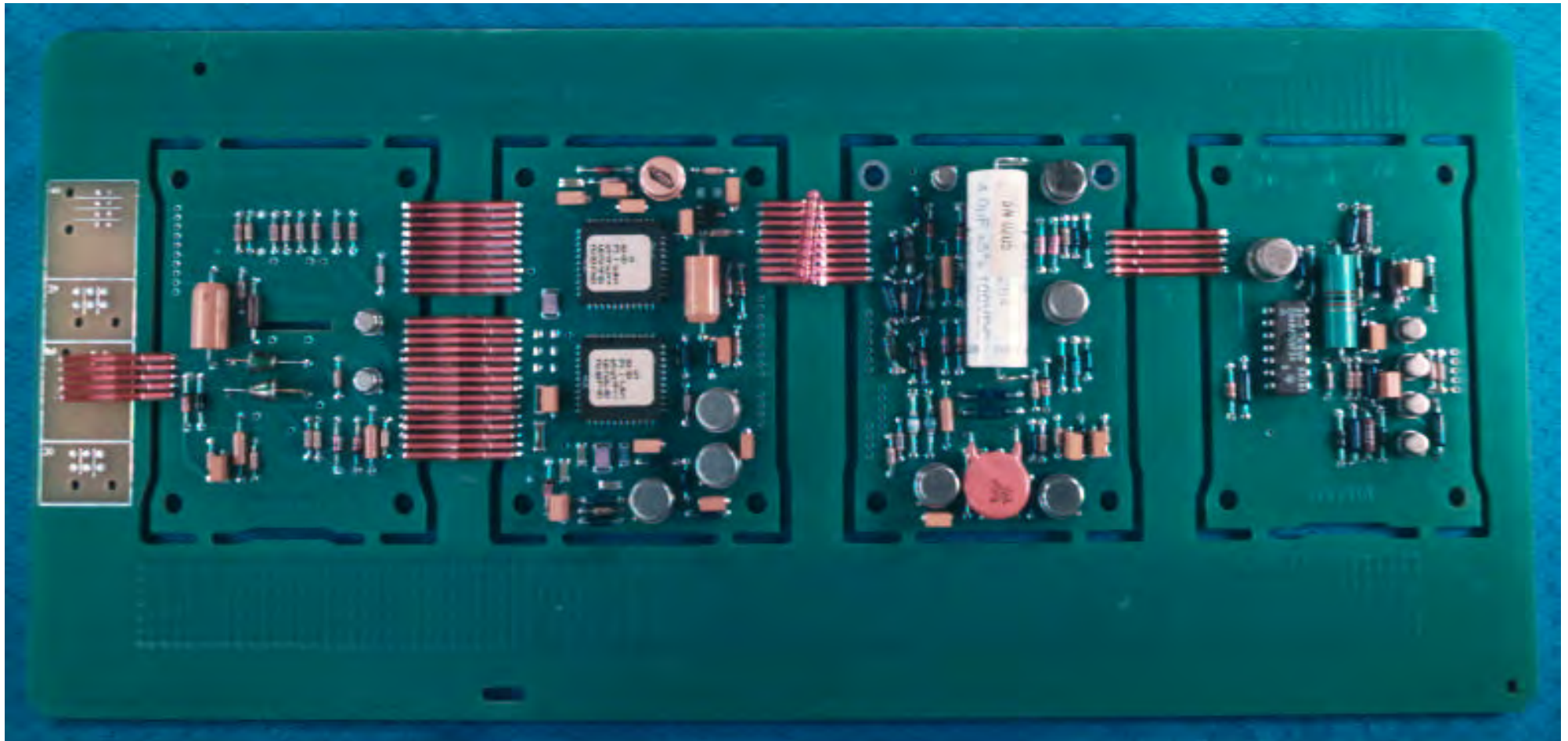

SEI

DAYRON

KDI

RAYMOND



# FMU-139B/B Implementation

- 2 ASICs replace the SAU FPGAs
- KDI improved the switching regulator
  - Higher efficiency toroidal inductor
  - All 3 select resistors eliminated
- Components are predominantly surface mount



SEI

DAYRON

KDI

RAYMOND



# FMU-139 B/B Prototype Panel

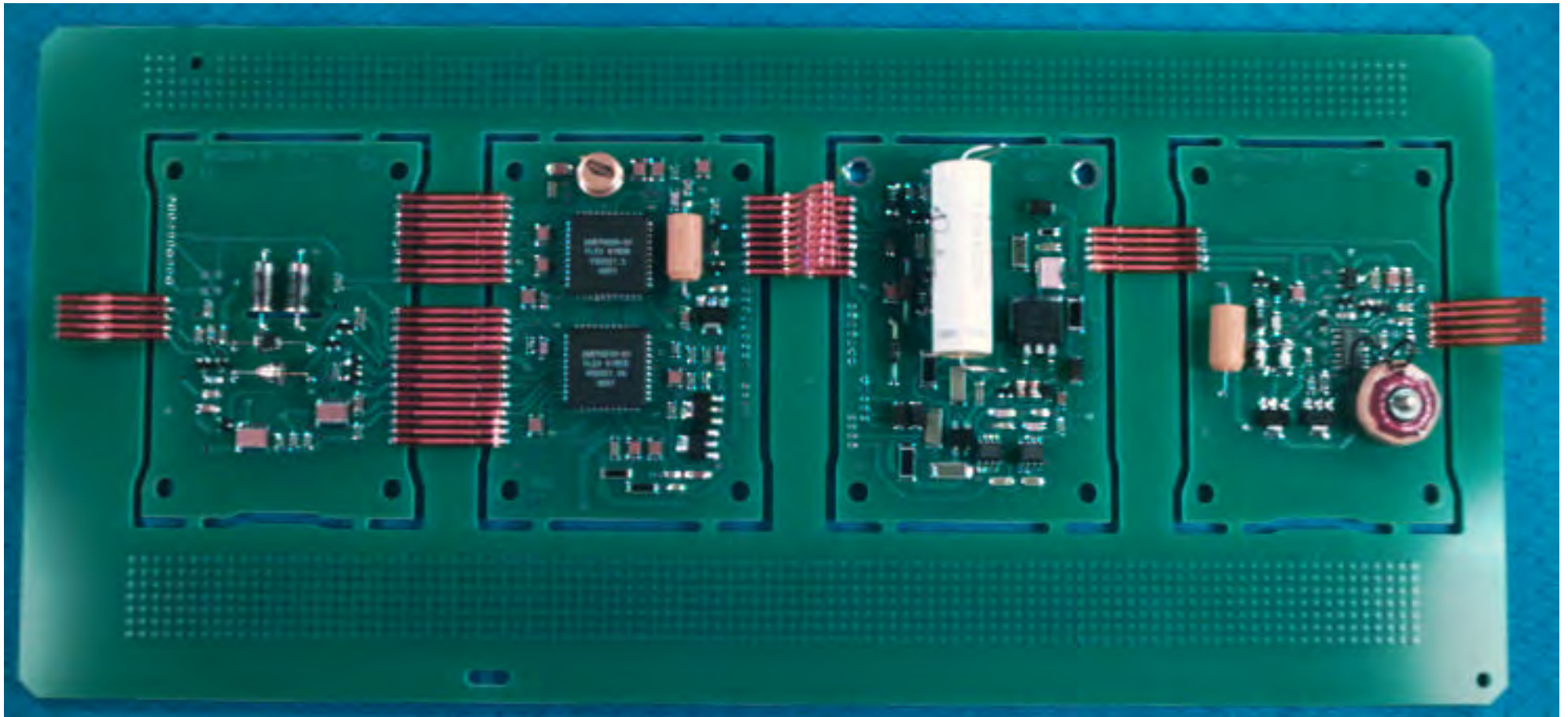

SEI

DAYRON

KDI

RAYMOND



# FFCS Mode Energy Balance

$$\frac{1}{2} C_1 V_1^2 = \frac{3}{2} C_2 V_2^2 + (V_{\text{bus}}) (i_{\text{ave}}) (t)$$

C1 → Main energy storage capacitor

C2 → PAF capacitor

Let:  $C_1 = 4.0 \mu\text{F}$ ,  $C_2 = 47 \mu\text{F}$

$V_1 = 195$ ,  $V_2 = 9$ ,  $V_{\text{bus}} = 3.8$

For:  $t = 60$  seconds,  $i_{\text{ave}} = 308 \mu\text{A}$



SEI

DAYRON

KDI

RAYMOND





# TEAM FUZING

## Benefits of the Team Fuzing Design Changes

- Operating duration when powered in FFCS mode exceeds the original FMU-139 A/B
- Extended operating duration facilitates higher altitude bomb release
- Modern and reliable manufacturing process.
- Potential cost reduction.
- Based on proven design.



SEI

DAYRON

KDI

RAYMOND





# 45<sup>th</sup> Annual NDIA Fuze Conference



## Mechanical Packaging of the EX 433 Proximity Fuze for Submunitions



18 April 2001

**Eugene Marquis**

**NSWCDD G34**

**Fuze Branch**





MK 45 MOD 4  
Gun Mount

EX 3 Submunition  
w/ EX 433 Proximity  
Fuze



ERGM: Extended Range Guided Munition





# M80 PIP Objective

- To package the electronics and mechanical components of the Proximity Fuze in the shape and size of the current M234 SD Slider for the M80 Submunition for ERGM
  - One-for-One replacement of current Slider

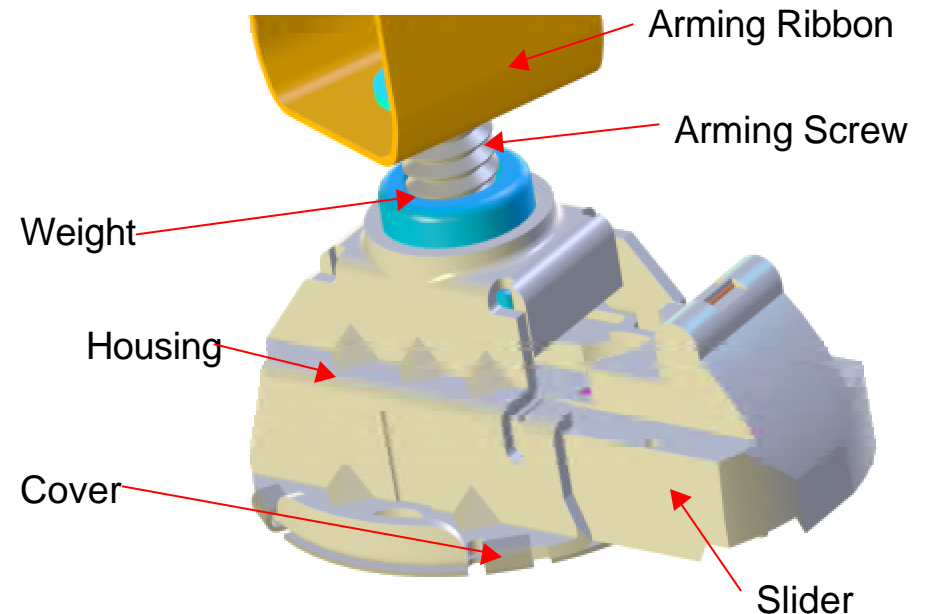
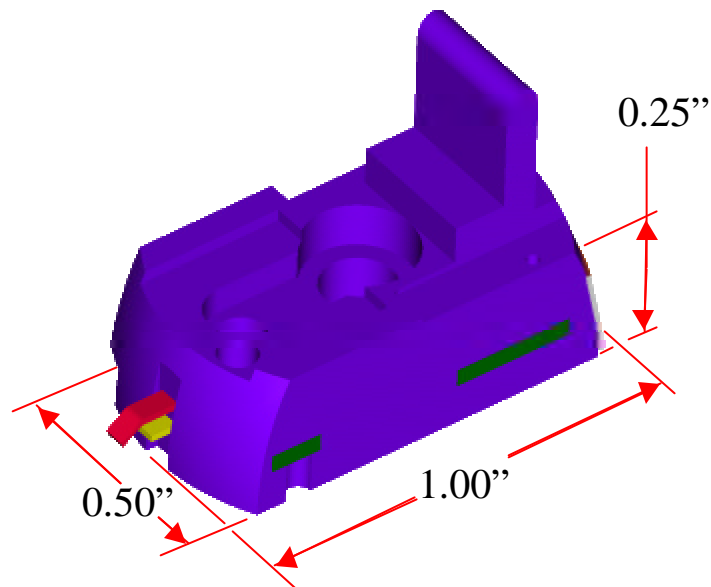



# M234 Self-Destruct Fuze



M80 w/  
M234

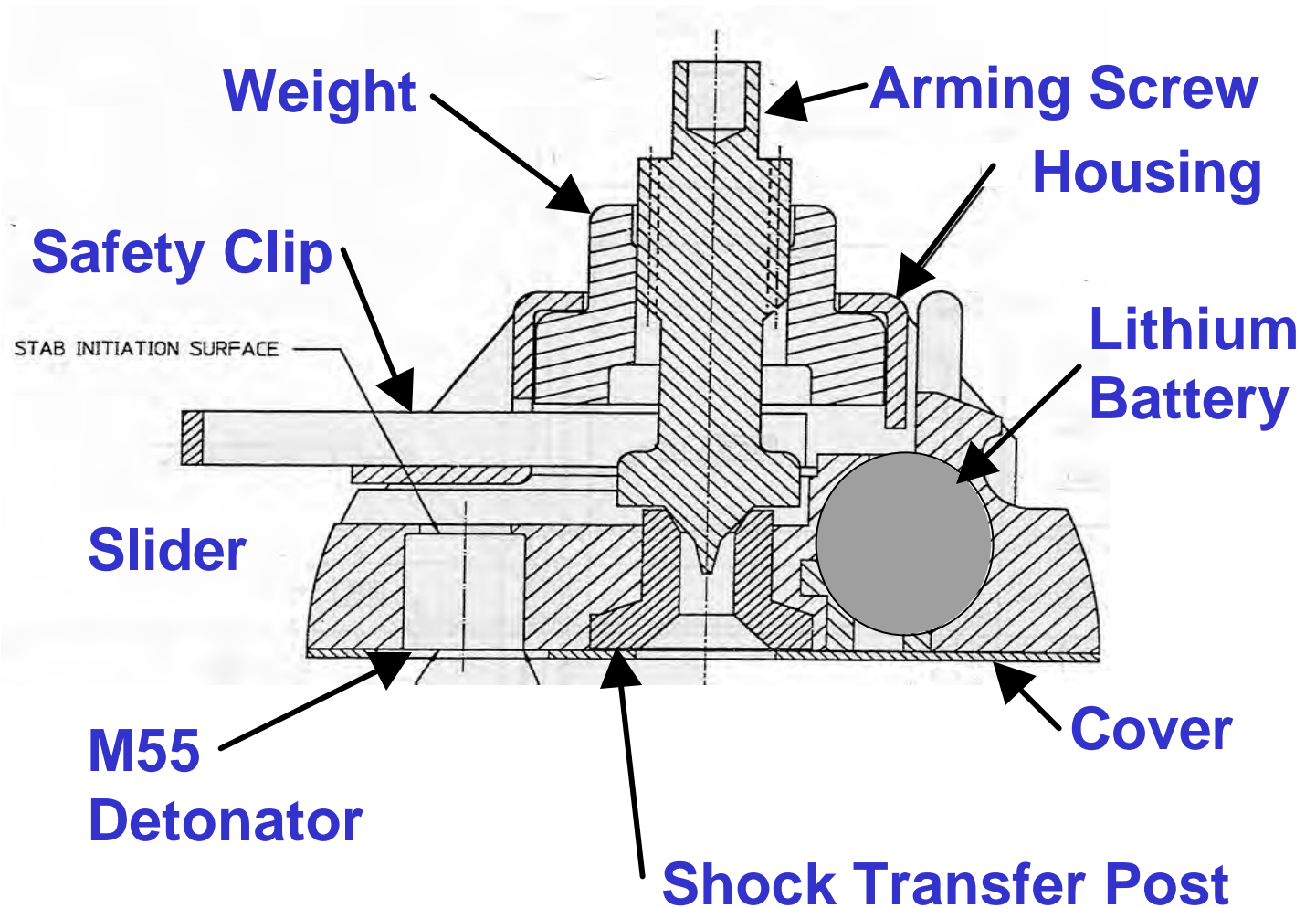



# Parts removed from M234

- **Battery Activation System removed**

- Spring
- Lever (hammer)
- Pivot
- Spiral Ribbon Assy
- Ball

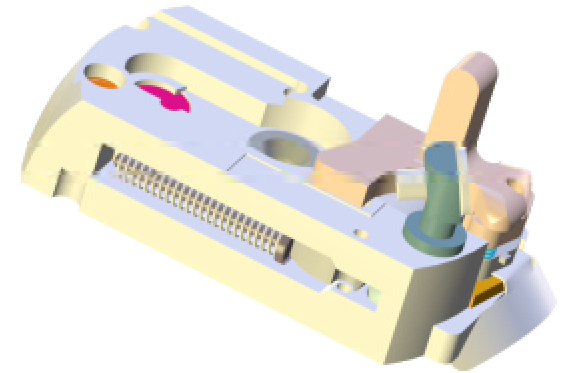
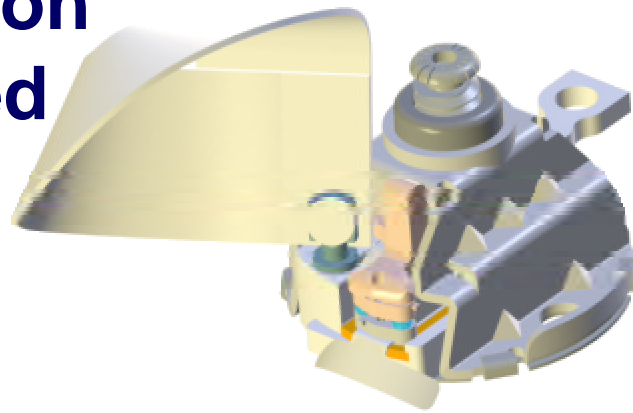

- **Shunt and Safety Pin removed**

- **Battery Cover removed**

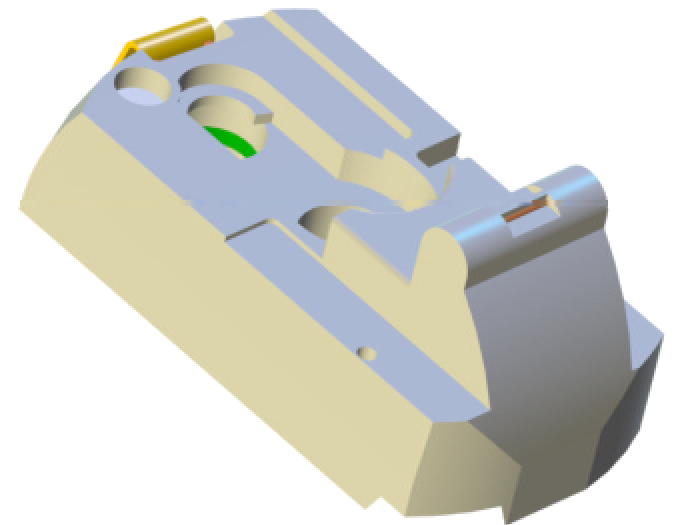



# Functions

---

---

- **Primary Mechanical Safety And Arming Features of the M234 SD Fuze Retained**
  - Impact Firing System is now the backup
- **Prox Fuze electronics will use two timers**
  - Separation Timer
    - Ensures proper event sequence
      - Battery activation and unnesting
  - Self-Destruct Timer
    - Provides the current cleanup capabilities of M234 SDF
      - Self-Neutralization or Self-Destruct



# Major Components Layout

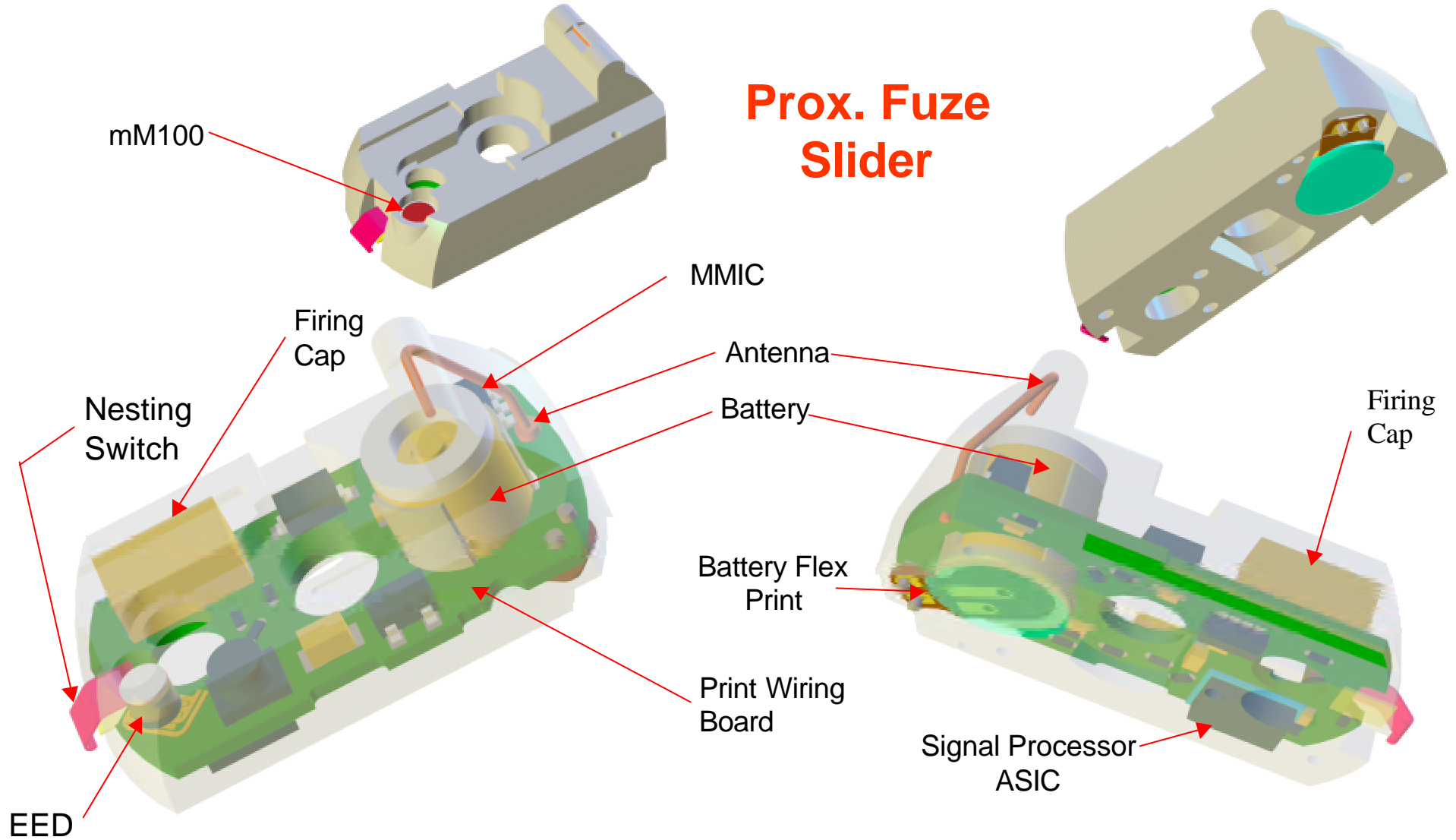



---

---

A cutaway diagram of a battery, showing internal components like the electrolyte, electrodes, and separator. The battery is shown in a perspective view, with a transparent outer casing. The internal components are colored in shades of blue, green, and yellow. The battery is mounted on a grey base.

# Battery

## Nesting Switch

### mM100



# Battery

**Nesting Switch**

**mM100**





MK45 MOD4

**Direction of Flight**



ERGM



EX-3



Slider



Prox. Fuze Battery

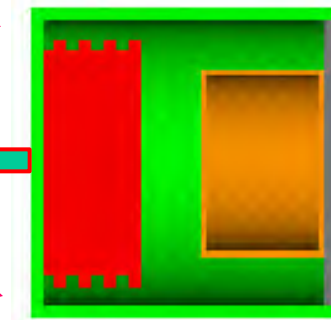

Force

Battery slides during Set Back



# Battery

- Requires a small nub to be molded into the plastic or a feature on the Battery
- Flex Print connection to Print Wiring Board
- Weight may be added to increase activation energy

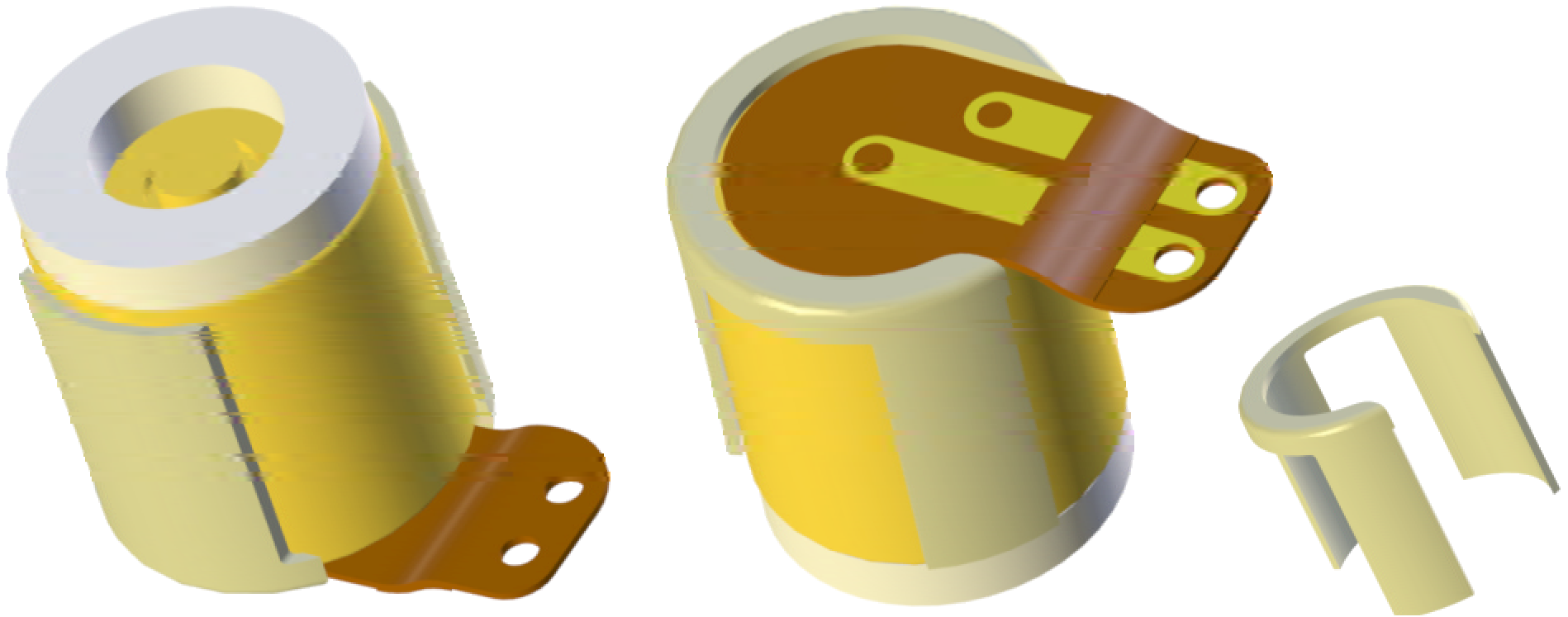



# Taller Slider

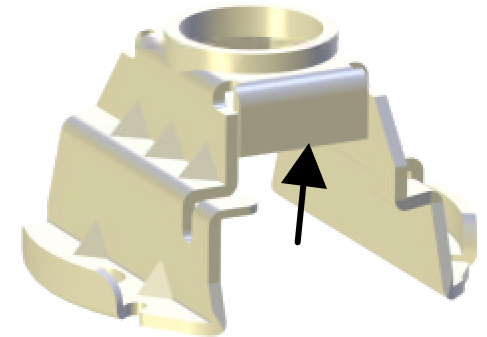
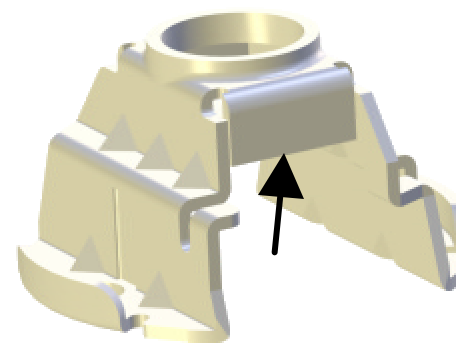
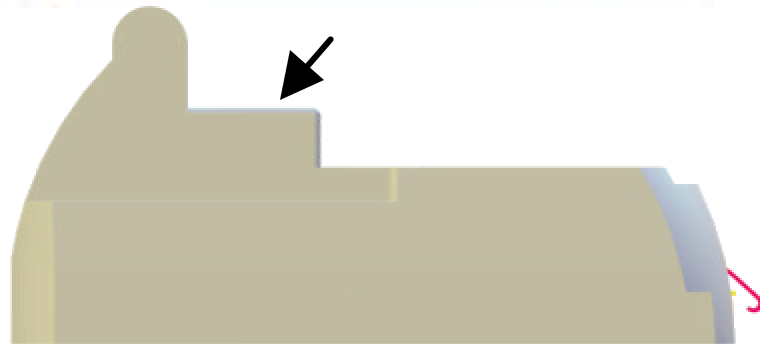
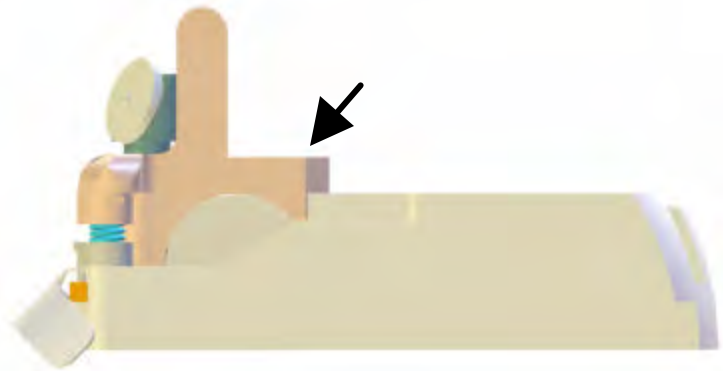

- **Slider height increased to allow maximum room for Battery**

- **Tab on front of M234 Housing has been shortened**



**Battery**

**Nesting Switch**

**mM100**

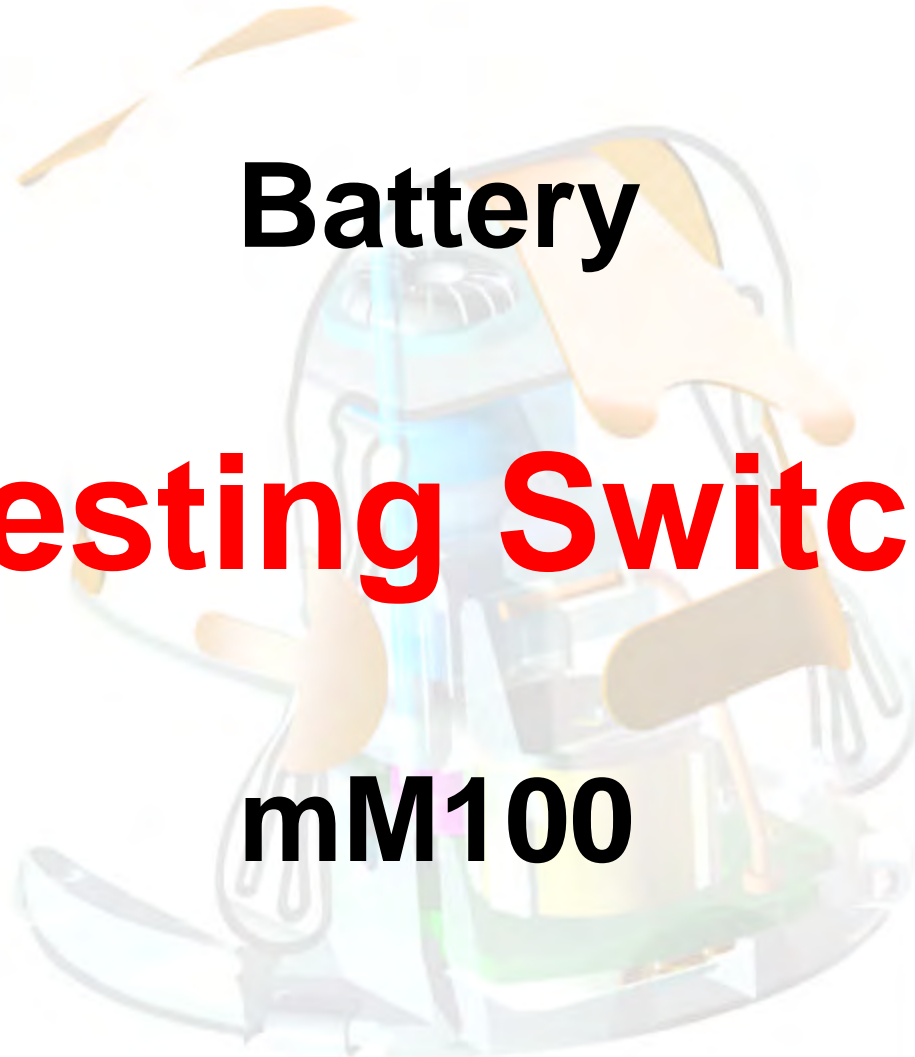



# Nesting Switch

- **Description**

- Replaces the function of the Shunt on the M234 SDF
  - Self-Destruct timer
  - Room needed for Antenna, Battery, & electronic components
- Prox. Fuze Sensor off line until submunitions dispensed
  - Reduces power consumption until M80's dispensed
- Closed while the submunitions are nested in the payload

- **Allows Self-Destruct time to be reduced from 3 minutes to 60 seconds - desired by Marines**



# Nesting Switch

## Nesting of grenades closes switch contacts

- **Fault Tree Analysis**
  - Shows the use of the Nesting Switch to be as safe as the Shunt
- **Safety Analysis**
  - Lone Star Army Ammunition Plant Concurs

**Nested Submunitions**

Nesting Switch compressed by stacked submunition



**Flight Time  
48 sec. to 8 min.**

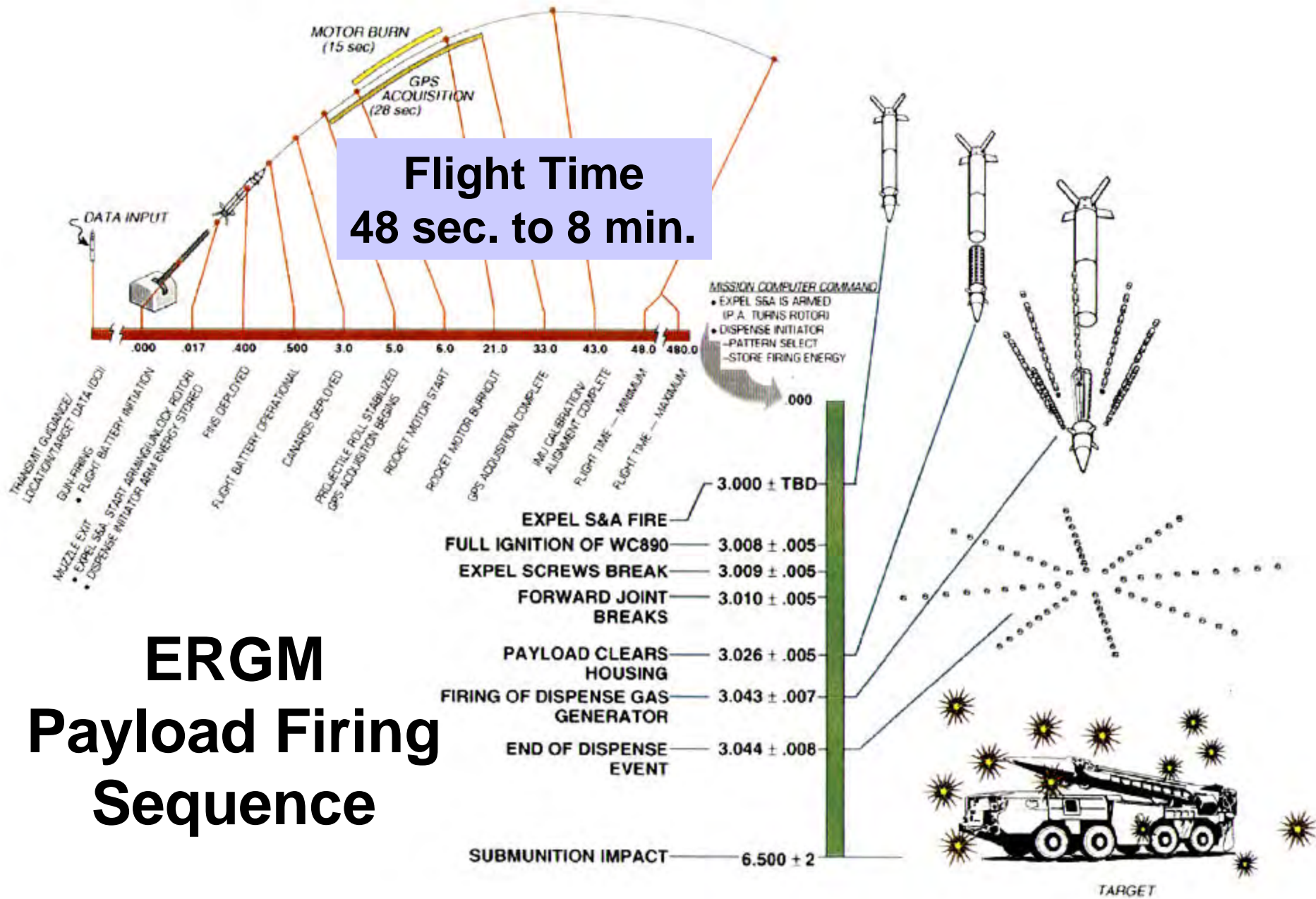



# Accident Scenario

- **Assumption:**

- The accident in some way has activated the Battery and the electronics are powered up
  - Drop, Accidental Expulsion

- **Safety Logic:**

- The Signal Processor IC will compare the Nesting Switch condition and Separation Timer (Battery activation time)
  - If the Nesting Switch is opened within 30 seconds of Battery activation the Prox. Fuze will safe itself
  - If the Nesting Switch is closed in the nested state and the Battery has been activated for 10 minutes the Prox. Fuze will safe itself

**\* Point Detonate Safety Issue still a concern**



# Nesting Switch Concept #1

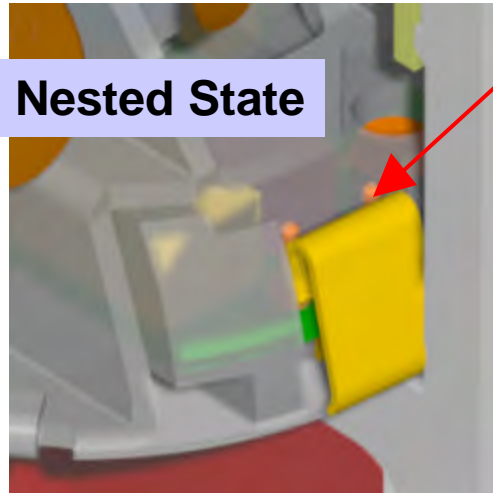
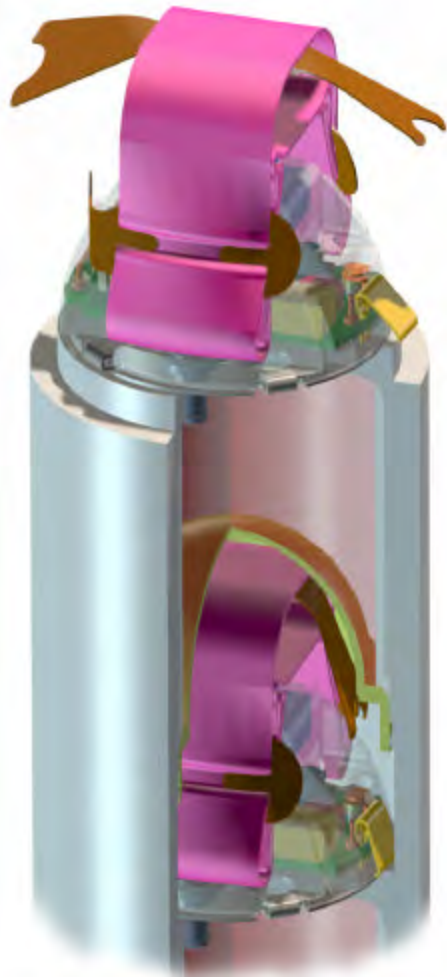

Nested State

Note: NO Gap

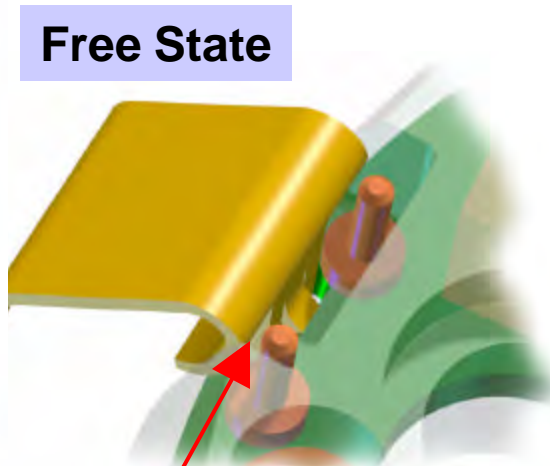

Free State

Note: Gap

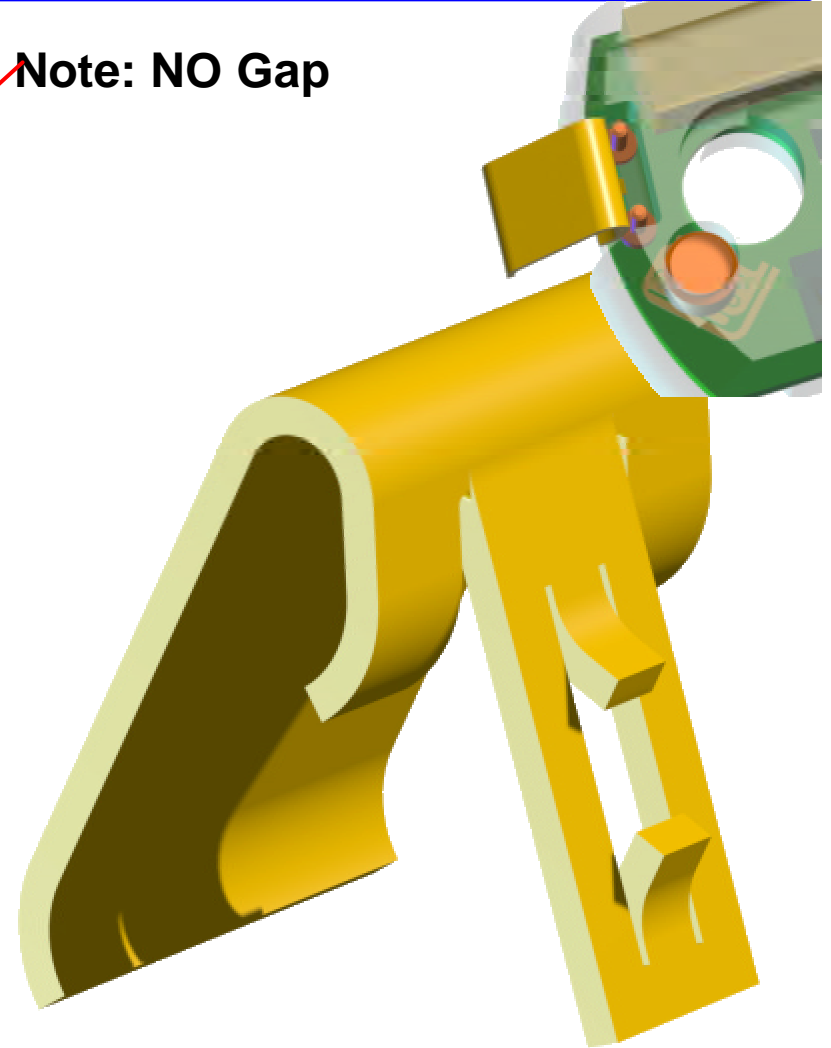



# Nesting Switch Concept #2

- The PWB is molded to form the Slider
- The two Nest Switch leaves are molded together
- Then soldered to the Slider Sub-Assembly

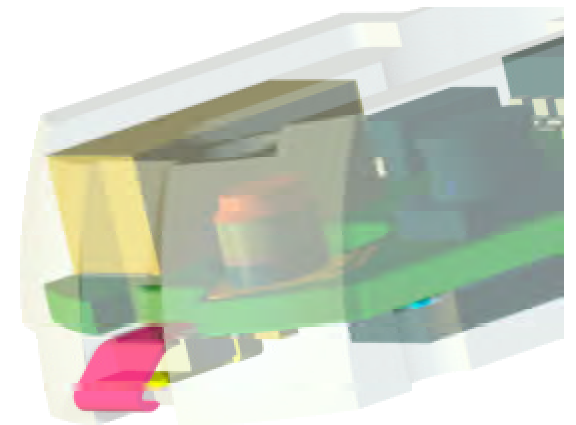
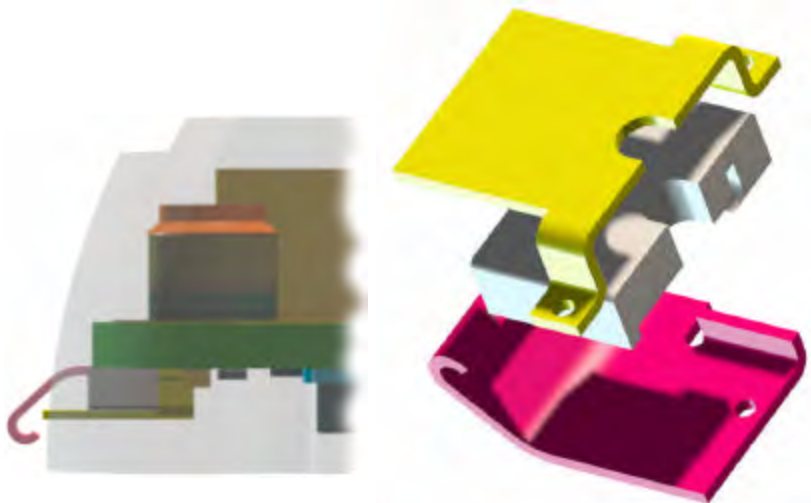
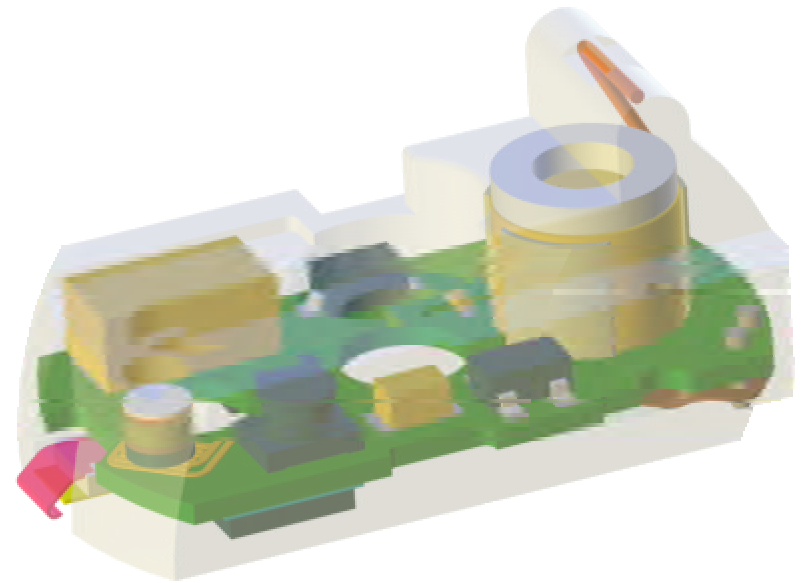

A 3D cutaway illustration of a battery, showing internal components like the electrolyte, electrodes, and a central separator. The battery is shown in a perspective view, with a light blue and green color scheme. The text is overlaid on this image.

# Battery

## Nesting Switch

### mM100



# EED vs. mM100

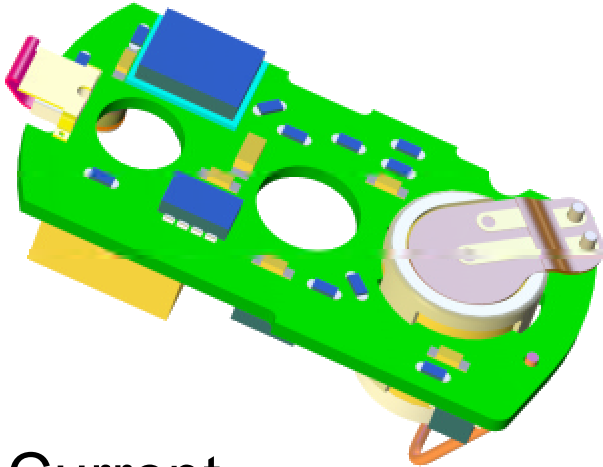

Current  
M234 EED  
Version

- mM100 design offers
- Reduced component count
  - Reduced component sizes
  - Reduced testing
  - Single sided PWB
  - Reduced PWB costs
  - Increase reliability

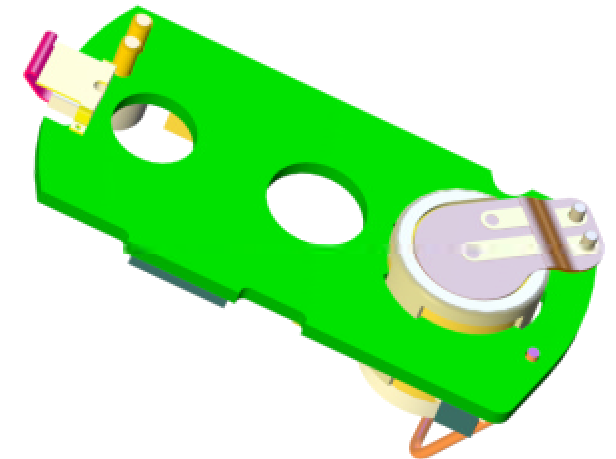

mM100  
Version

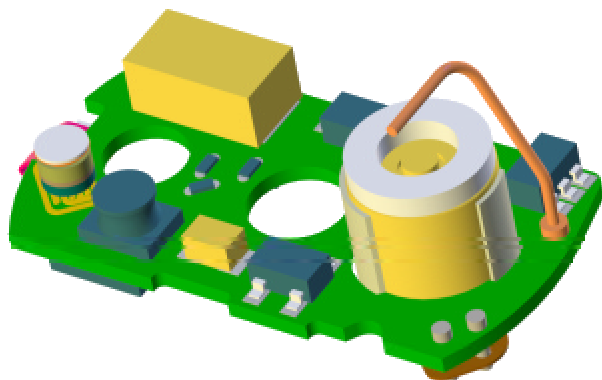

- No impact on battery
- Either Nesting Switch concept

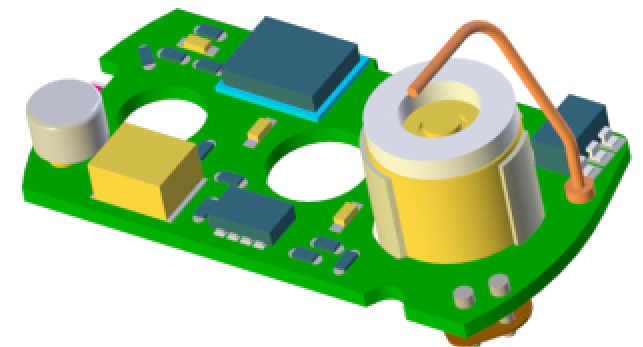



# Summary



- **Teamwork**

- Government and Contractor
- Battery, Electronics, and Mechanical Packaging Teams

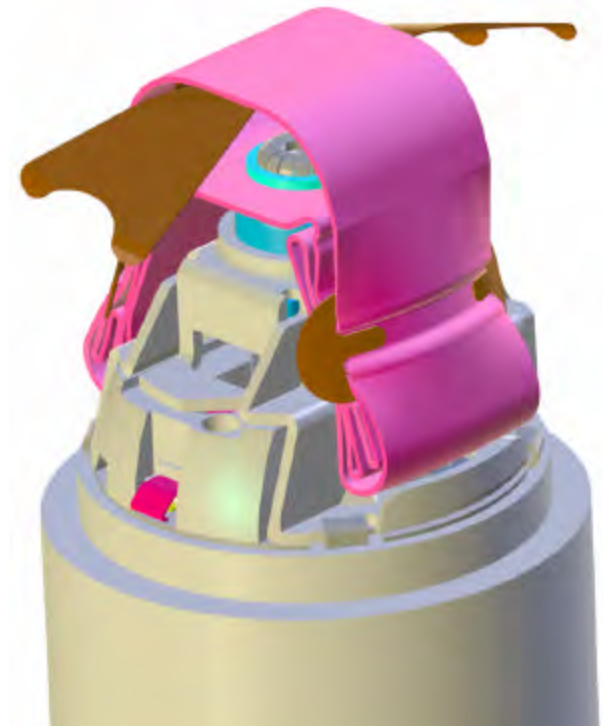
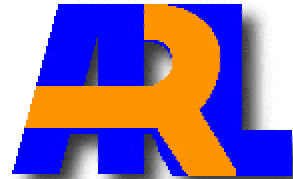

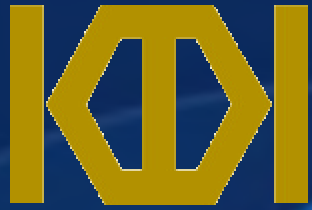

# KDI Precision Products, Inc.

An ISO 9001 Registered Company

## 45th Annual Fuze Conference

"The Evolving Nature of Value Added Fuzing"



Presented by: Mr Ted Lewis

[www.kdi-ppi.com](http://www.kdi-ppi.com)



# GUIDED MLRS USA AND FOREIGN PARTNERS



# KDI PROGRAM TEAM

- Mike Buckhanan - Program Manager
- Ted Lewis - Electrical Project Engineer
- Cory Hatch - Electrical Engineer
- Tony Zucker - Mechanical Project Engineer
- Mike Sowder - Test Equipment Electrical Engineer
- Steve Gemperline - Quality Engineer, CQE
- Bob Garrett - Reliability Engineer
- Tom Moore - Manufacturing Engineer
- Bob Butts - Configuration Management



# GMLRS OPERATION

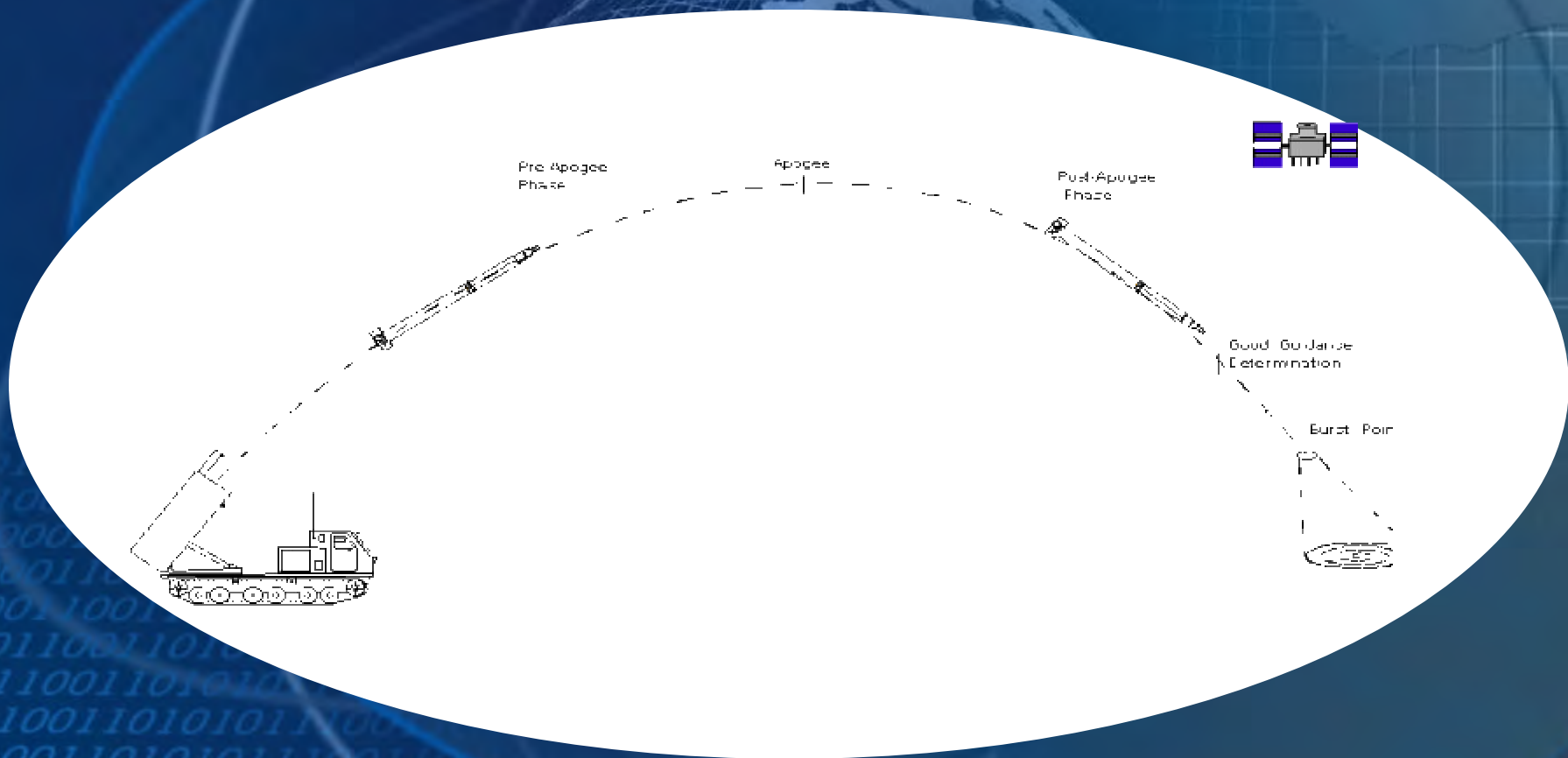

# GMLRS ROCKET

- The GMLRS Rocket Is Nominally a Ballistic Round
- The Maximum Off-axis Shot Is 4° Degrees
- The Canards Are Used Only for Trimming the Trajectory During the Flight

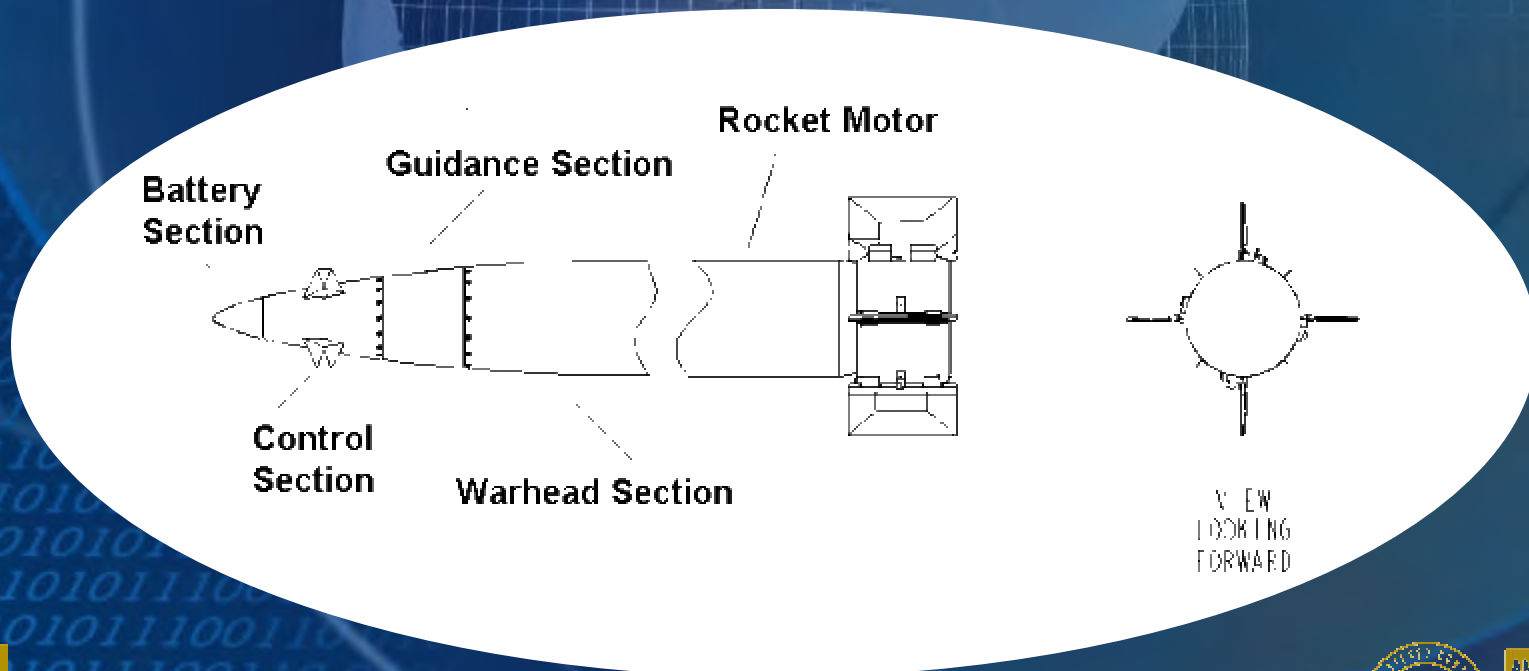

# GUIDANCE AND CONTROL SECTION

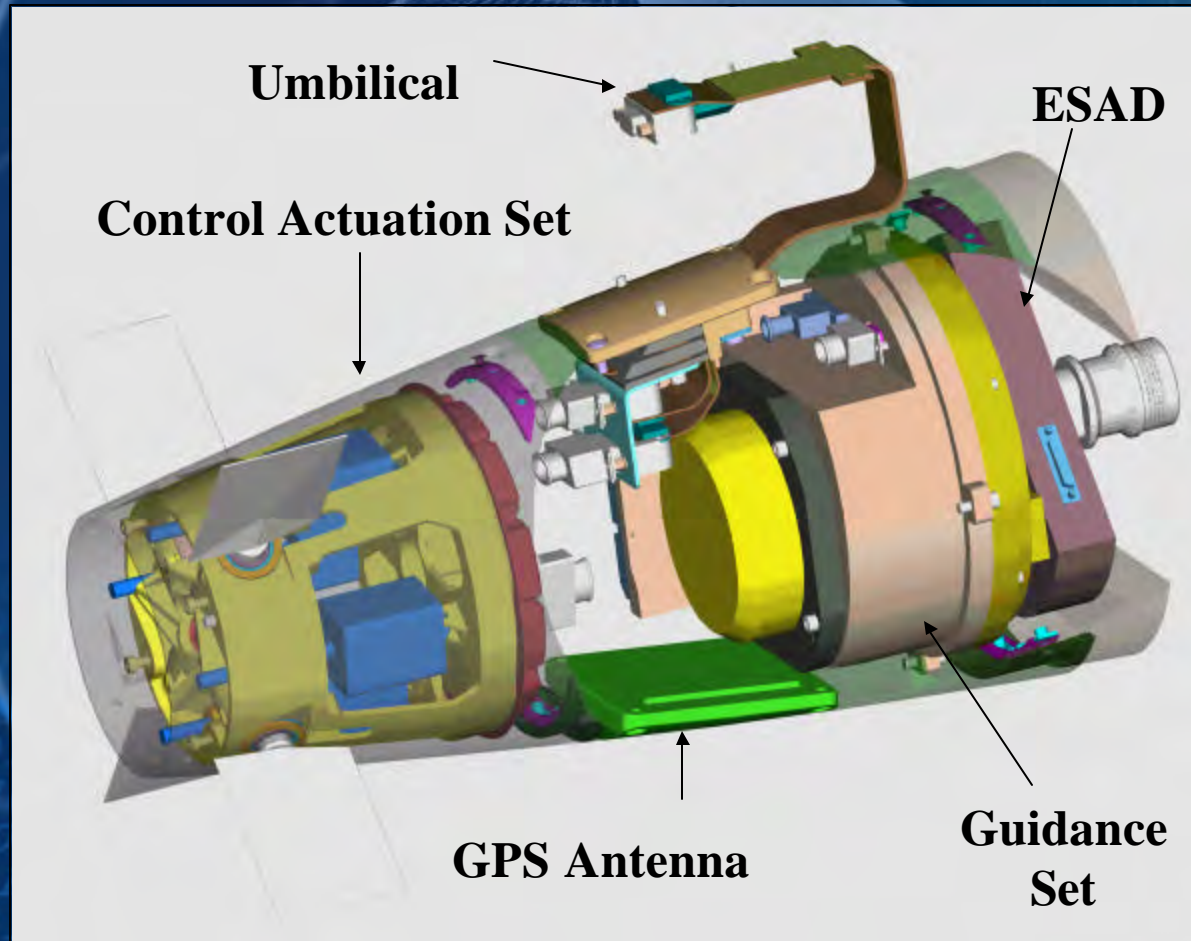

# HOUSING

- Material: 304L Stainless Steel
- Function
  - Interfaces to LEEFI Adapter Assembly
  - Interfaces With Rocket
  - Alignment Feature Incorporated
  - Hermetic Environment
  - Supports Printed Wiring Board (PWB)



# SEALING

- The ESAD Will Be Hermetically Sealed and Tested to Meet a Leak Rate of  $1 \times 10^{-6}$  cc/sec He/Mass Spectrometer at 1 Atmosphere Pressure Differential
- Laser Welding Will Be Used to Seal the Housing, Similar to the Other Qualified Programs at KDI
- The GMLRS ESAD Will Be Back-filled With Nitrogen With A Trace Of Helium Through A Fill Plug



# EXPLODED VIEW

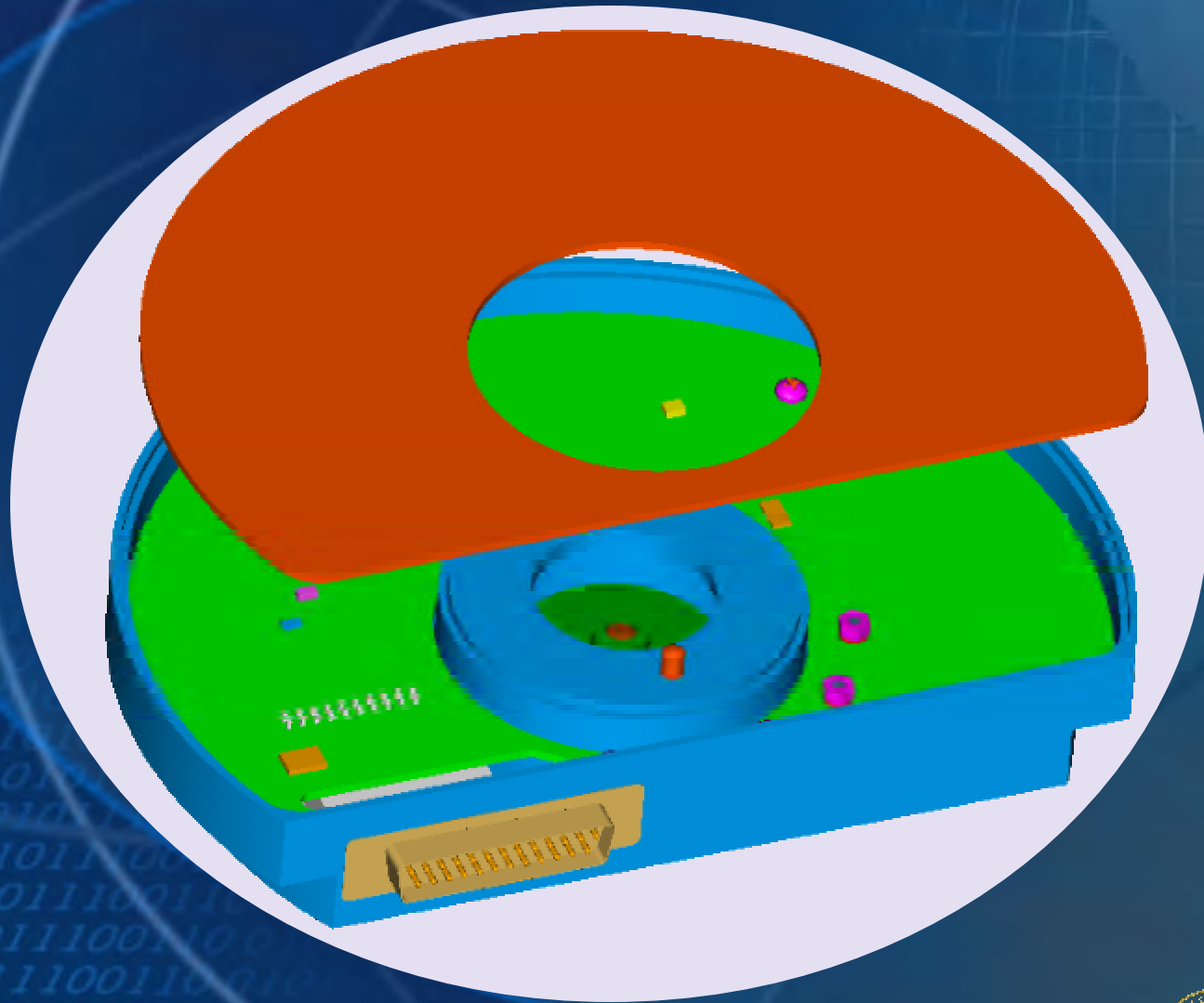

[www.kdi-ppi.com](http://www.kdi-ppi.com)



# LEEFI ADAPTER ASSEMBLY

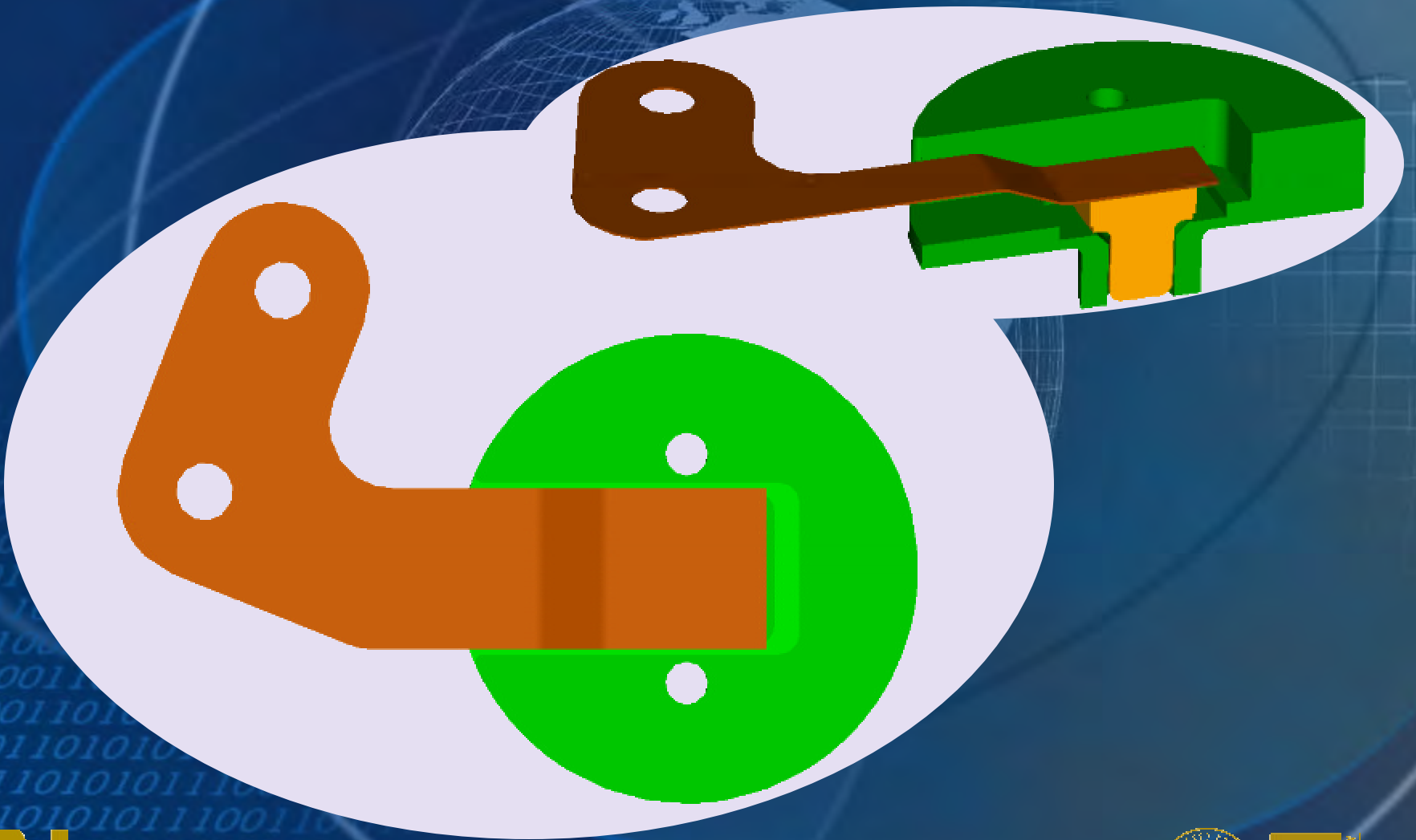

[www.kdi-ppi.com](http://www.kdi-ppi.com)



# GMLRS ESAD WITH LEEFI ADAPTER ASSEMBLY

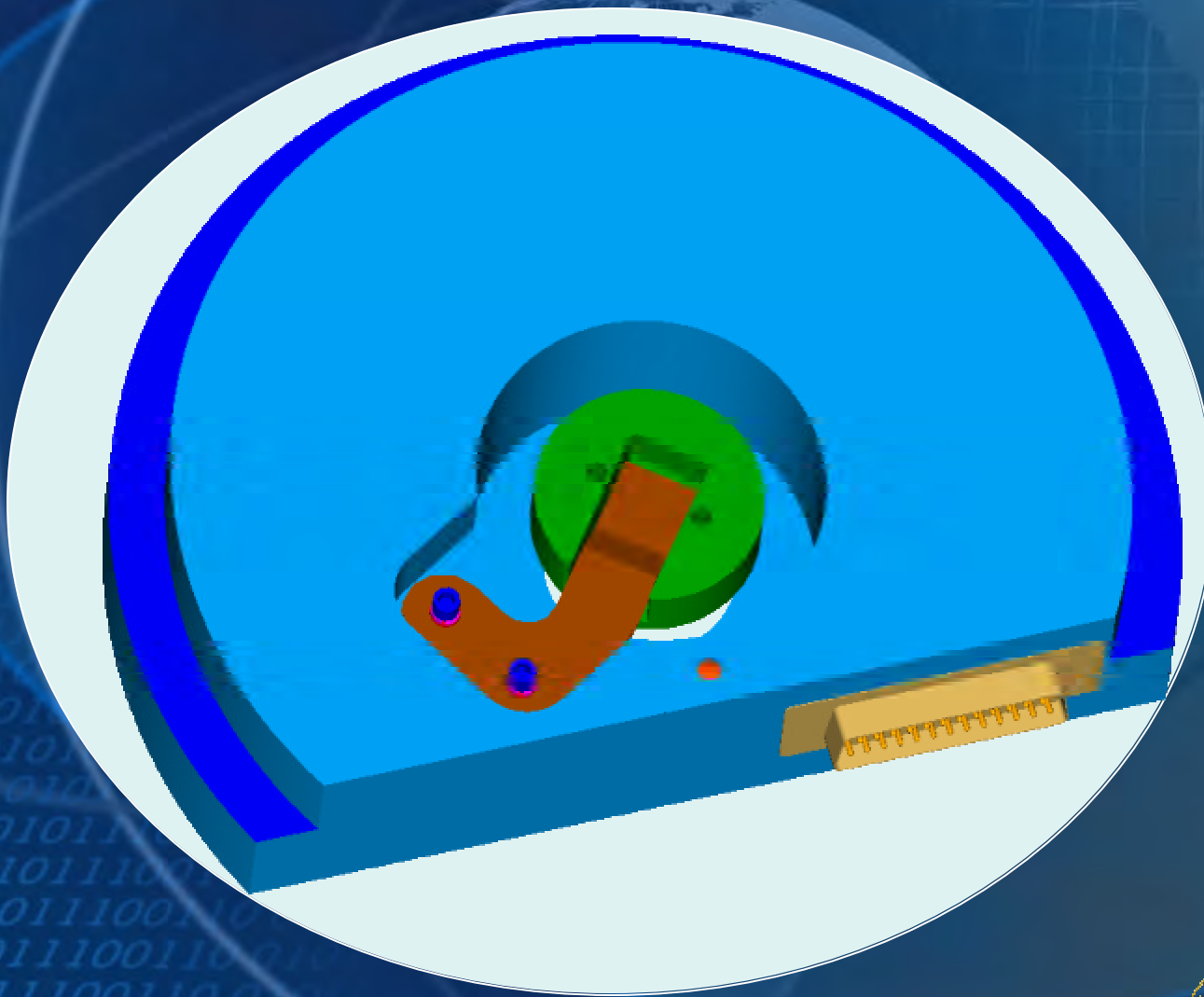

[www.kdi-ppi.com](http://www.kdi-ppi.com)



# DETAILED BLOCK DIAGRAM

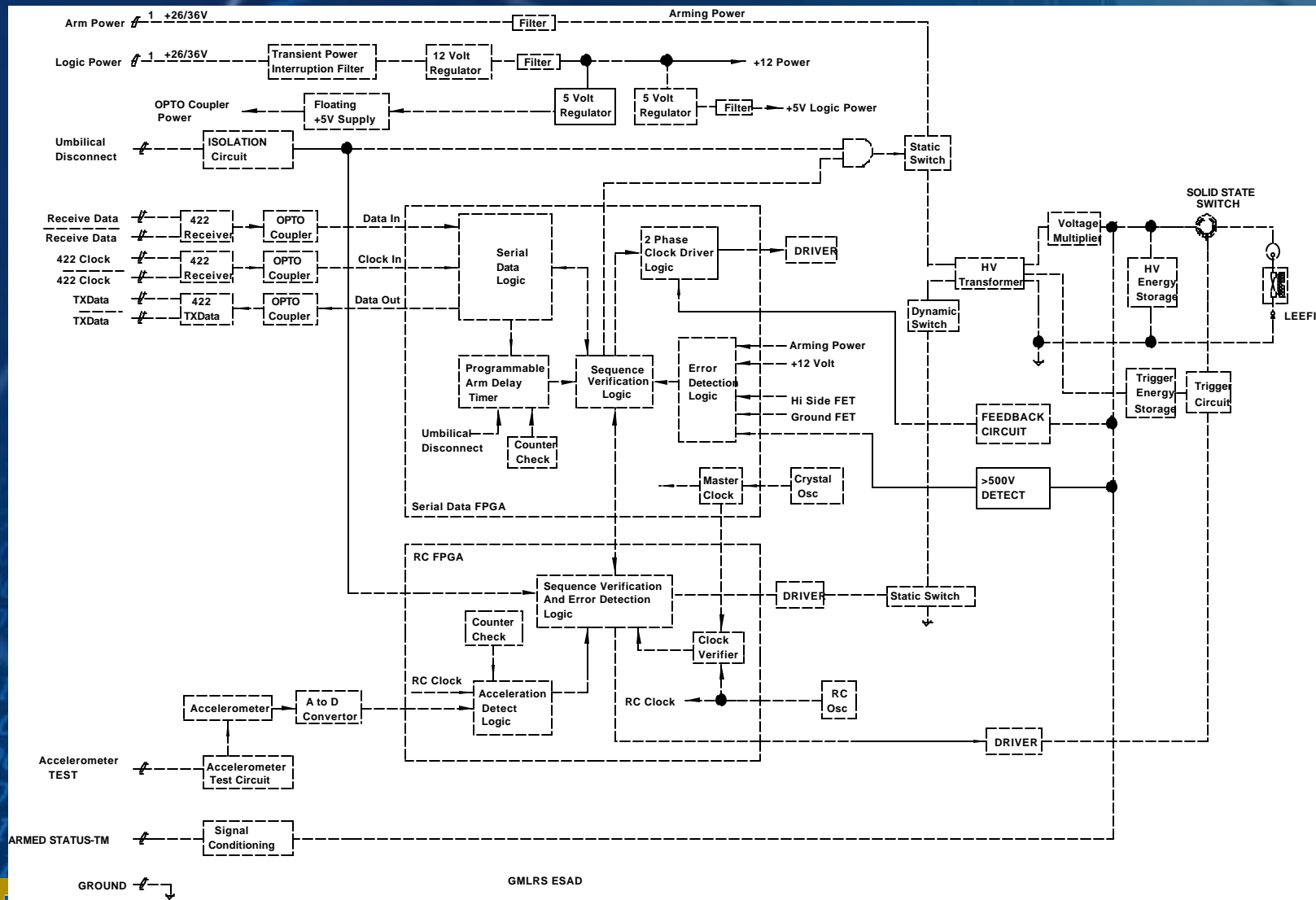

# TIMING DIAGRAM

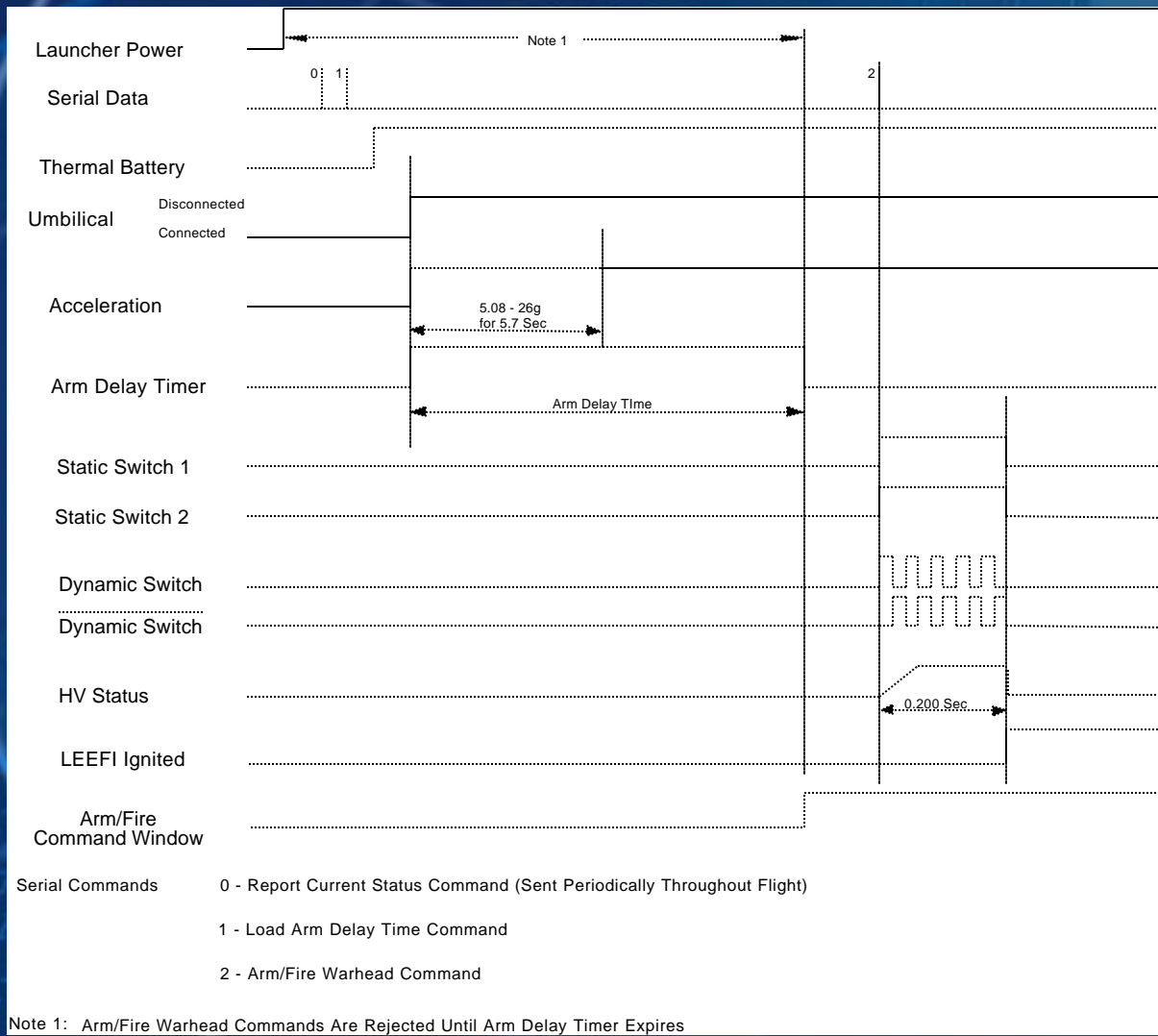

# SERIAL INTERFACE

- 442 Drivers/Receivers
- SDLC Message Formats

Guidance to ESAD  
Message

48 BITS

- 8 BIT Start Word
- 8 BIT Command Word
- 8 BIT Delay Time
- 16 BIT CRC
- 8 BIT Stop Word

ESAD to Guidance Message  
64 BITS

- 8 BIT Start Word
- 20 BIT Command Word
- 4 BIT Delay Time
- 8 BIT Timer Status
- 16 BIT CRC
- 8 BIT Stop Word



# ACCELERATION PROCESSING

- Motorola MMA1201P Analog Accelerometer
  - $\pm 40g$  Capacitive, Micromachined Accelerometer
  - Output Sensitivity =  $50 \pm 2.5$  mV/g
- Accelerometer Readings Are Taken Every  $340\mu S$
- Accelerometer Output Level Checked During BIT
- Accelerometer Output Level “Nulled” When Battery Power is Applied
- Specification Requirements:
  - 1st Motion =  $5.08g$  for 6 msec Within 0.5s From Umbilical Disconnect
  - Safe Separation =  $5.08g$  for  $5.7 \pm 0.1$  Seconds



# LEEFI ASSEMBLY

- Designed in Unison by China Lake, Reynolds Systems and Silicon Designs
- The LEEFI Has Been Qualified by China Lake IAW MIL-STD-331, Test G1
- Specific Tests Designed to Demonstrate the Initiator Meets a Reliability of 0.99 at a 95% Confidence Level Were Performed



# MCT SEMICONDUCTOR DISCHARGE SWITCH

- N-Type MOS-Controlled Thyristor
- 1400 Volt
- 4ka Surge Current
- Silicon Power Corporation
- Tested in KDI IRAD Program
  - > 20,000 Discharges



# PROGRAM STATUS / SCHEDULE

- Initial AFSRB Presentation - Completed 19 Dec 2000
- PDR - Completed 1-2 Feb 2001
- Engineering Tests - 15 Nov 2000 To 31 Mar 2001
- CDR - 27-28 Mar 2001
- Qualification - 30 May 2001 To 17 Jul 2001
- Flight Hardware Delivery 1 June -28 Sept 2001



# QUALIFICATION TESTING

- Twenty ESADS Will Be Subjected to Qualification Testing
- The Qualification Test Environments Will Consist Of:
  - Thermal Shock
  - Tactical Vibration
  - Launch Shock
  - High Temperature Operation
  - Low Temperature Operation
  - Acoustic Noise and Flight Simulation
- Electromagnetic Environment





# GIF

## *Guidance Integrated Fuze*

### NSWCDD G34 Fuze Branch

Mark Engel

Keith Lewis

Howie Wendt

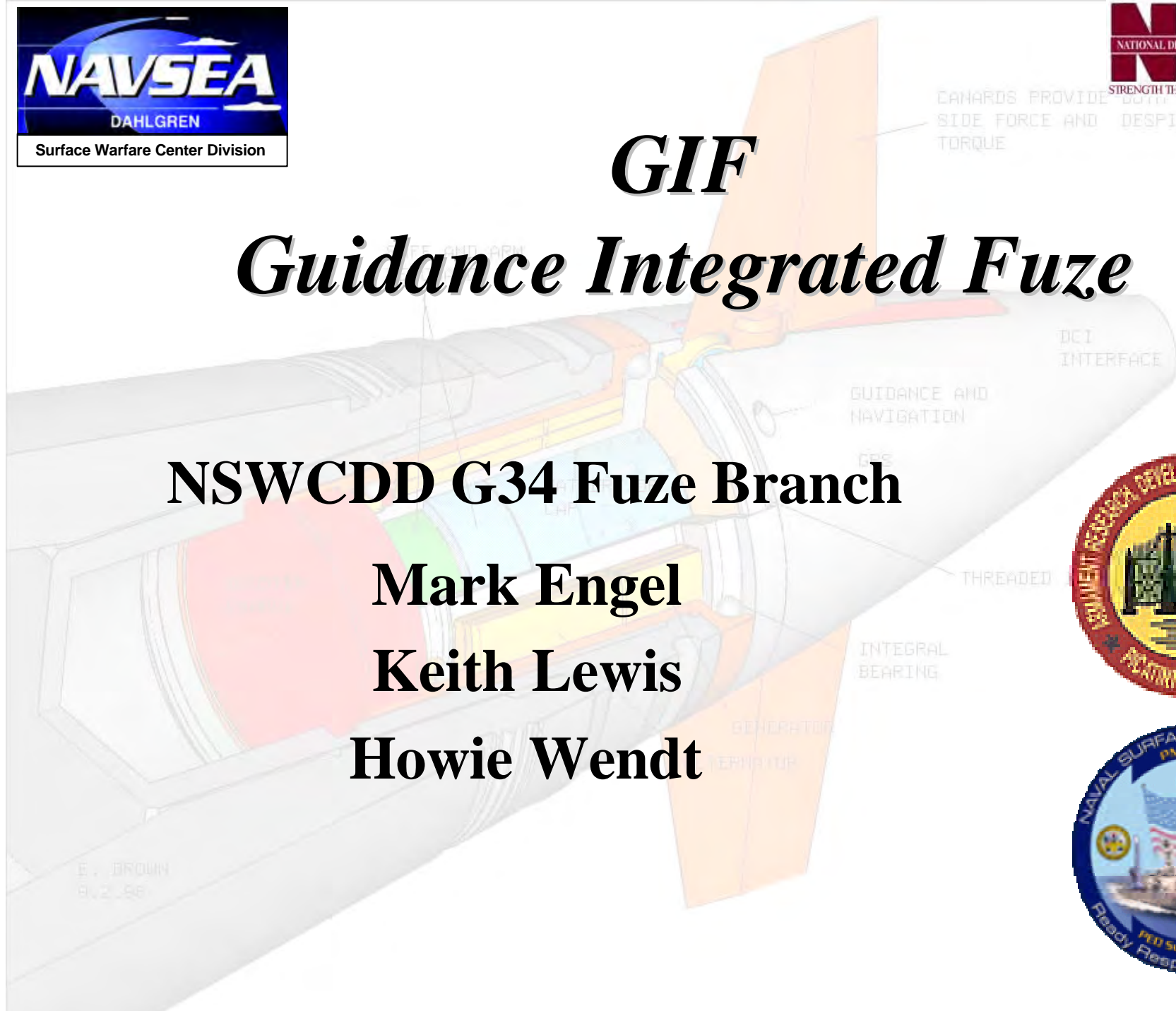



# Inaccuracy

---

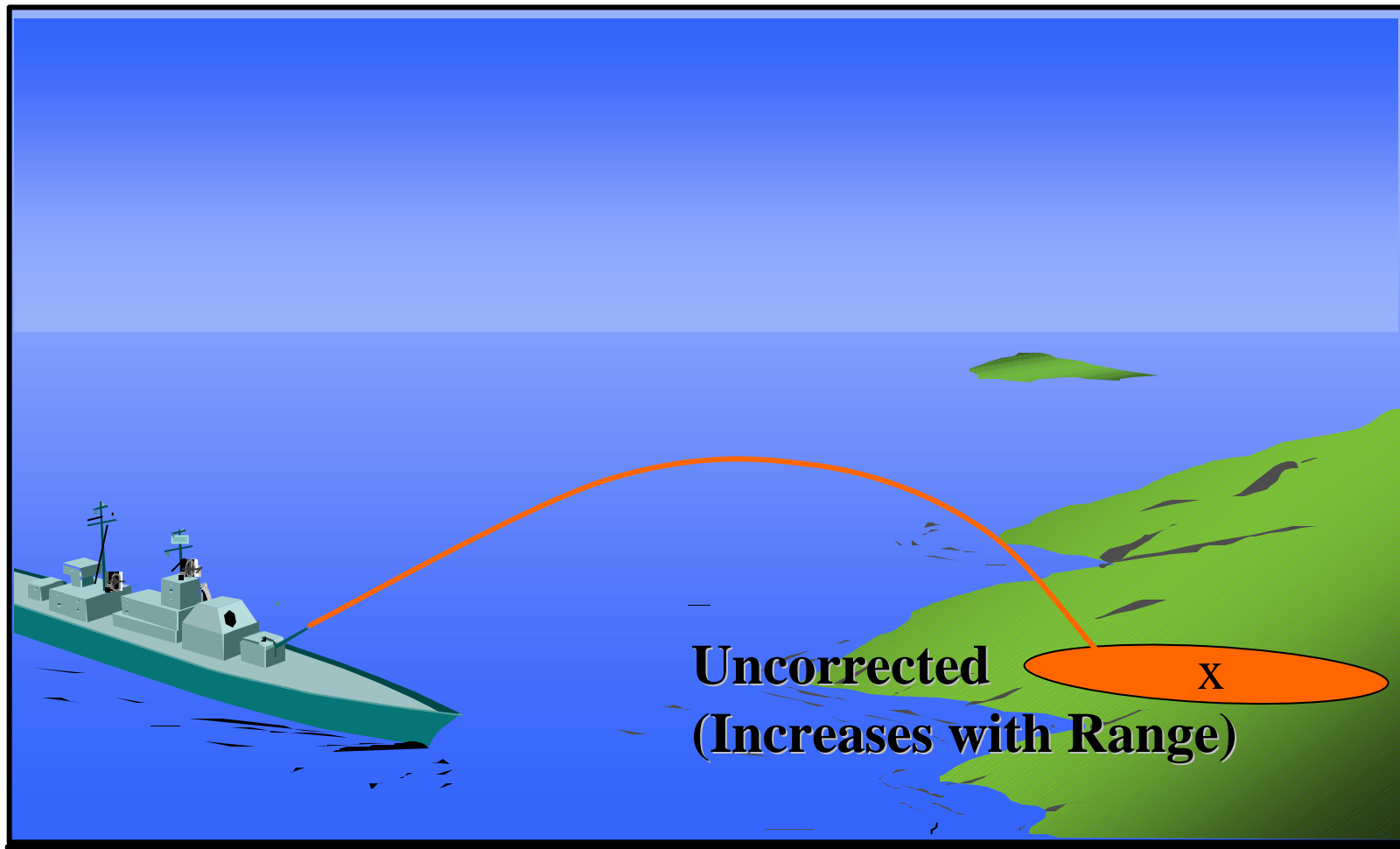



# Background

---

- Why? Improved Accuracy
- Who?
  - US Army, US Navy, Foreign Services
  - Industry
- Other Guided Projectiles:
  - CMATD
  - TCM
  - STAR
  - ERGM & LCGEU
  - XM-982
  - ANSR
  - Barrage



# 1-D vs. 2-D

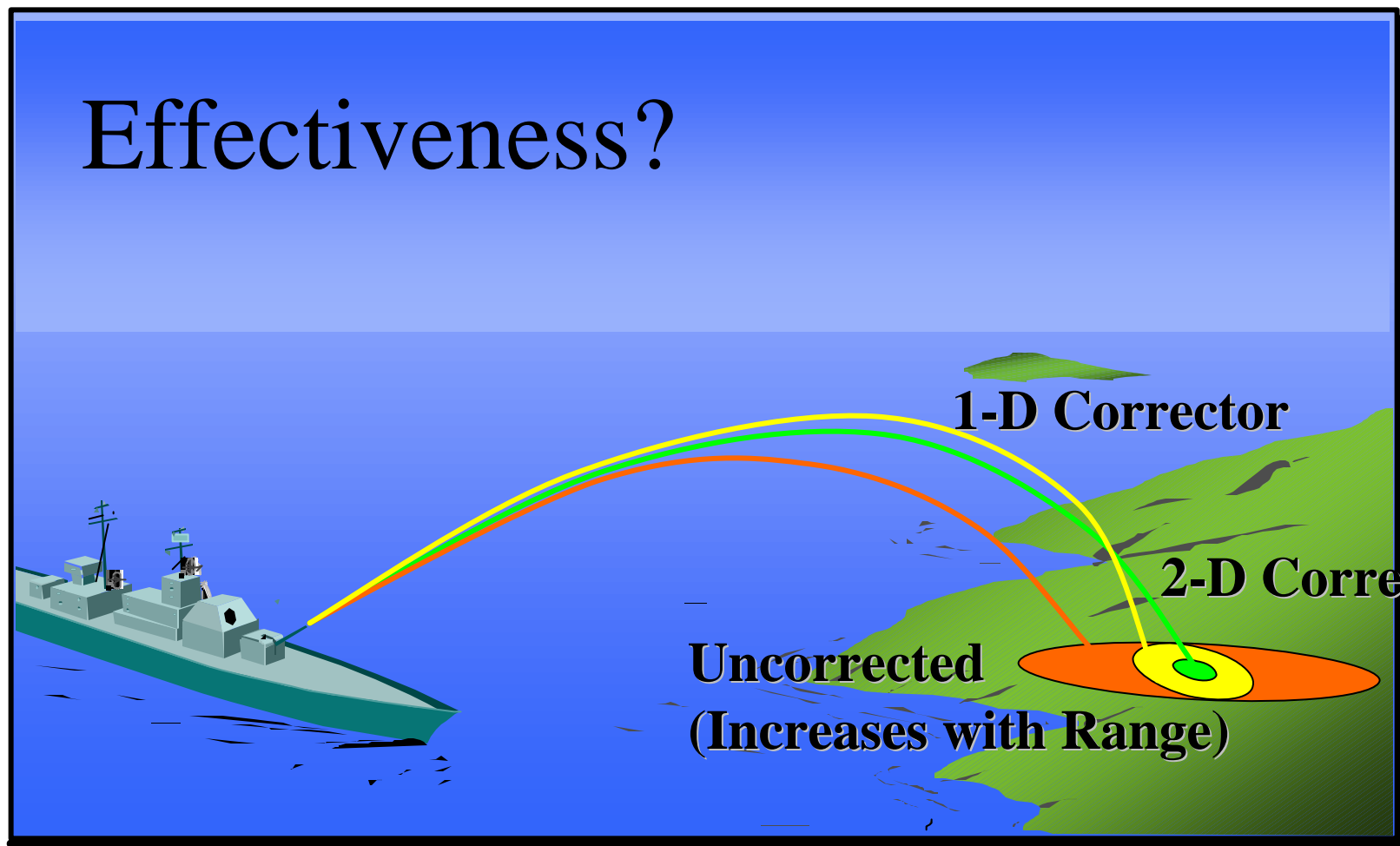



# Approach

---

- 1-D vs. 2-D? Team Star examining 1-D
- Can Canards Give Acceptable Control Authority?
- Will it Fit?



# Control Authority?

---

## ARDEC (Picatinny) Analyzing Trajectories with Canards



- ✓ Incorporated CMATD Aero into 7-DOF
- ✓ Compared Sample Runs with Draper 7-DOF
  
- ! Implementing Closed-Loop CMATD Guidance Algorithms
  - Simulate CMATD Flights for Check
  - Incorporate GIF Canards
  - Simulate GIF Flight for Maximum Control Authority

# First Step - Canards

- Canards
- Actuators

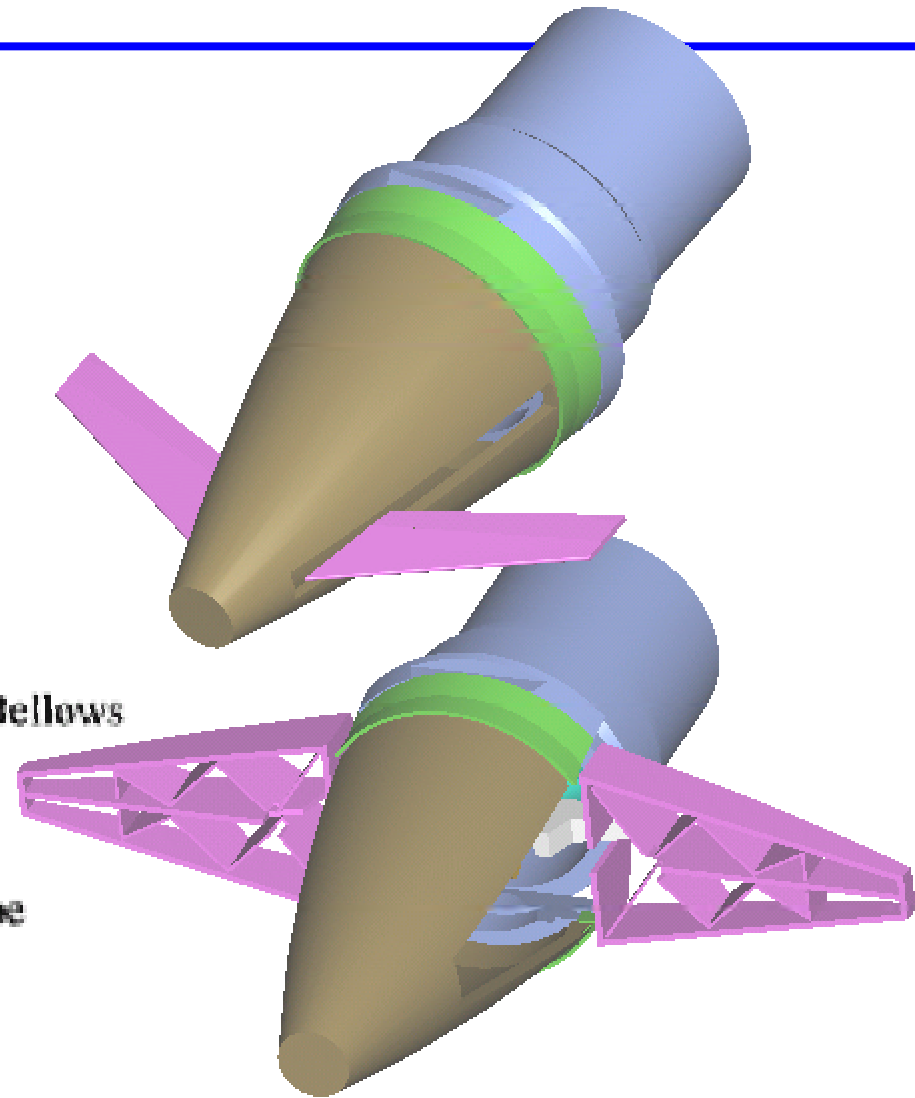
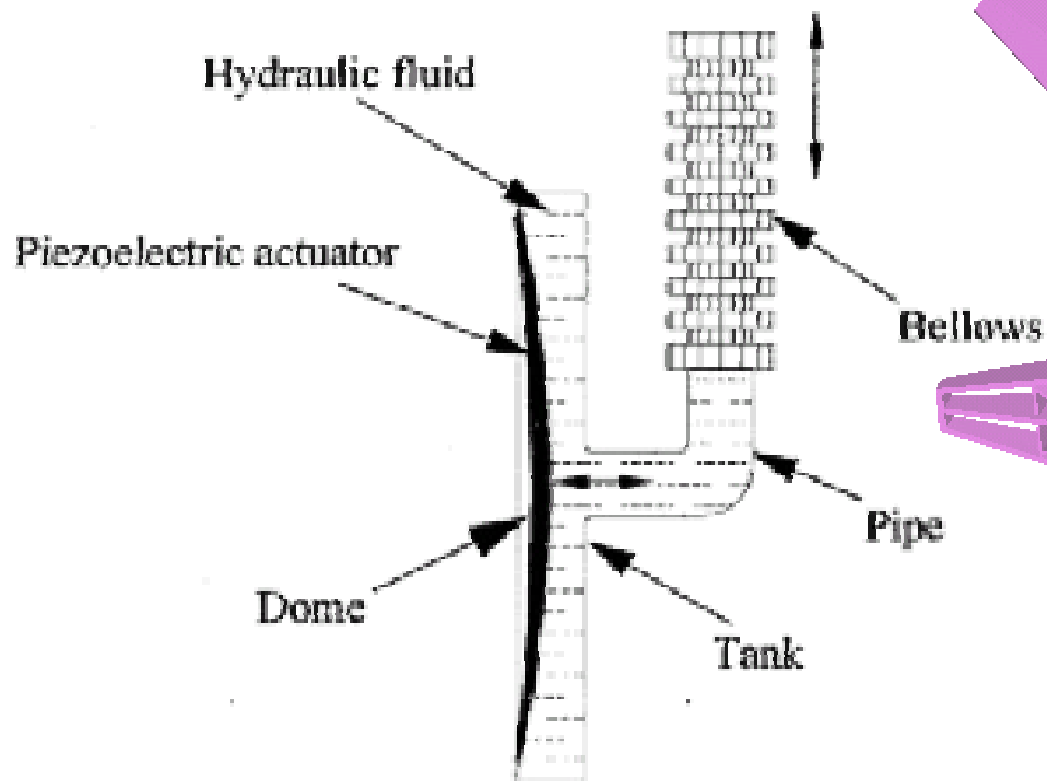

# Fit It In 9 Cubic Inches

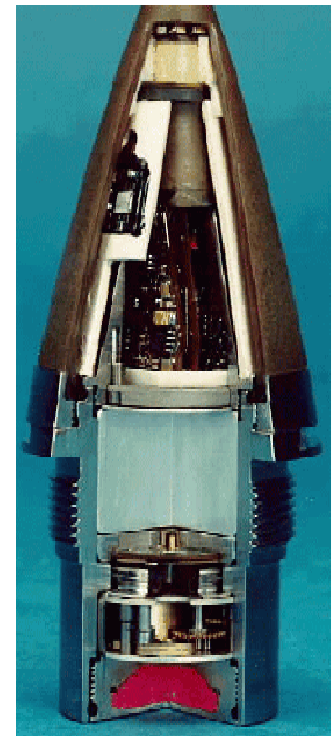
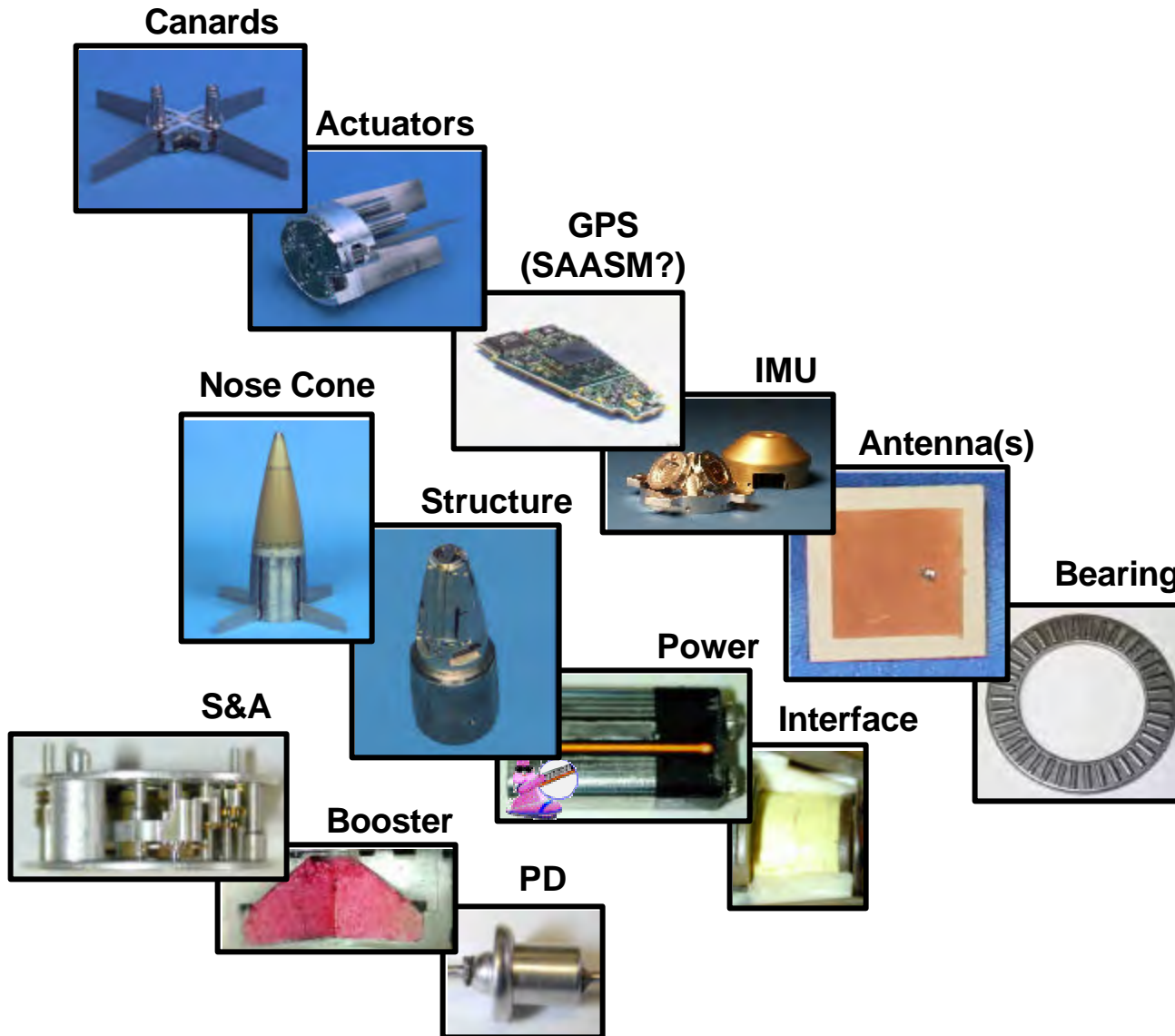

**NATO Standard Fuze**

# GPS/INS

- Looking for Existing Technology
- Looking for Future Technology

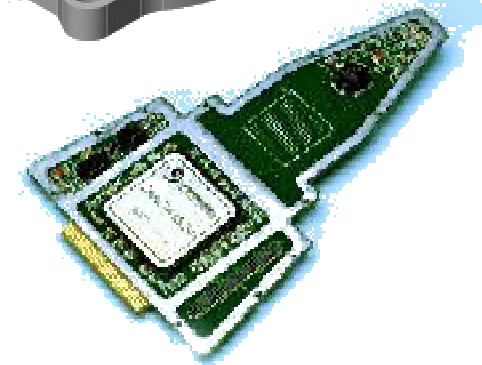
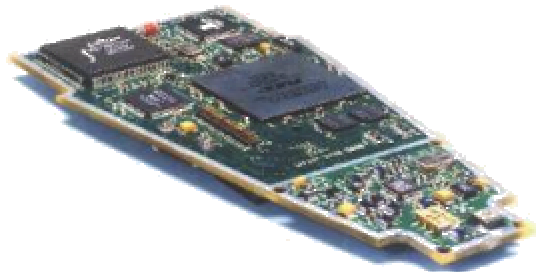
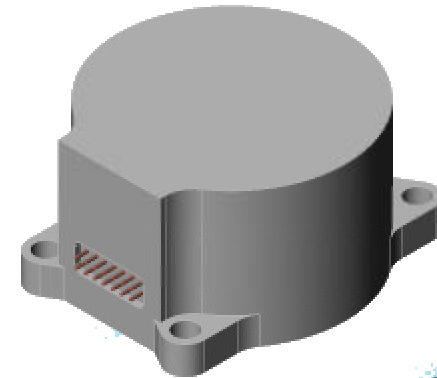
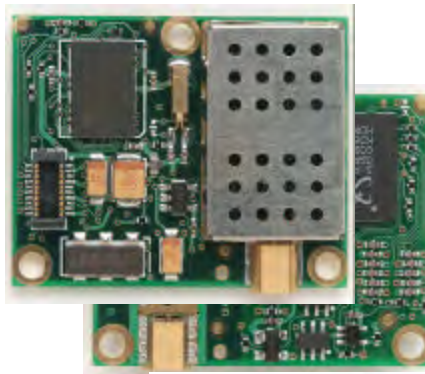



# Other Issues

---

- Battery vs. Generator
- MEMS S&A (but micro detonators?)
- Rolling Canards
- Single vs. Multiple Antennas
- Power Before Flight



# Near Term Plan

---

- Trajectories to Determine Control Authority
- Realistic Volume Allocation
- Options for Power and Rolling Canards
- Collect Data on GPS, INS, Actuators

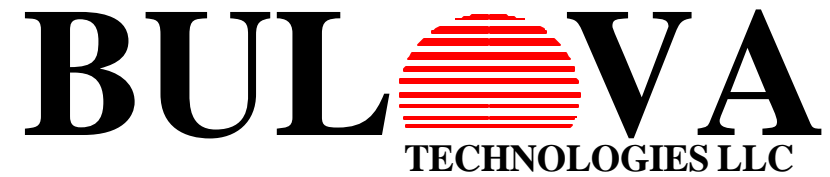

# MK 432 ELECTRONIC TIME FUZE

## *A New Fuze for the US Navy*

Chad Finch, G34 Fuze Branch

Dave Mengel, Bulova Tech



**TACOM**

*Mobility and Firepower  
for America's Army*





# Navy 5" Cargo Projectile EX 172 HE-ICM

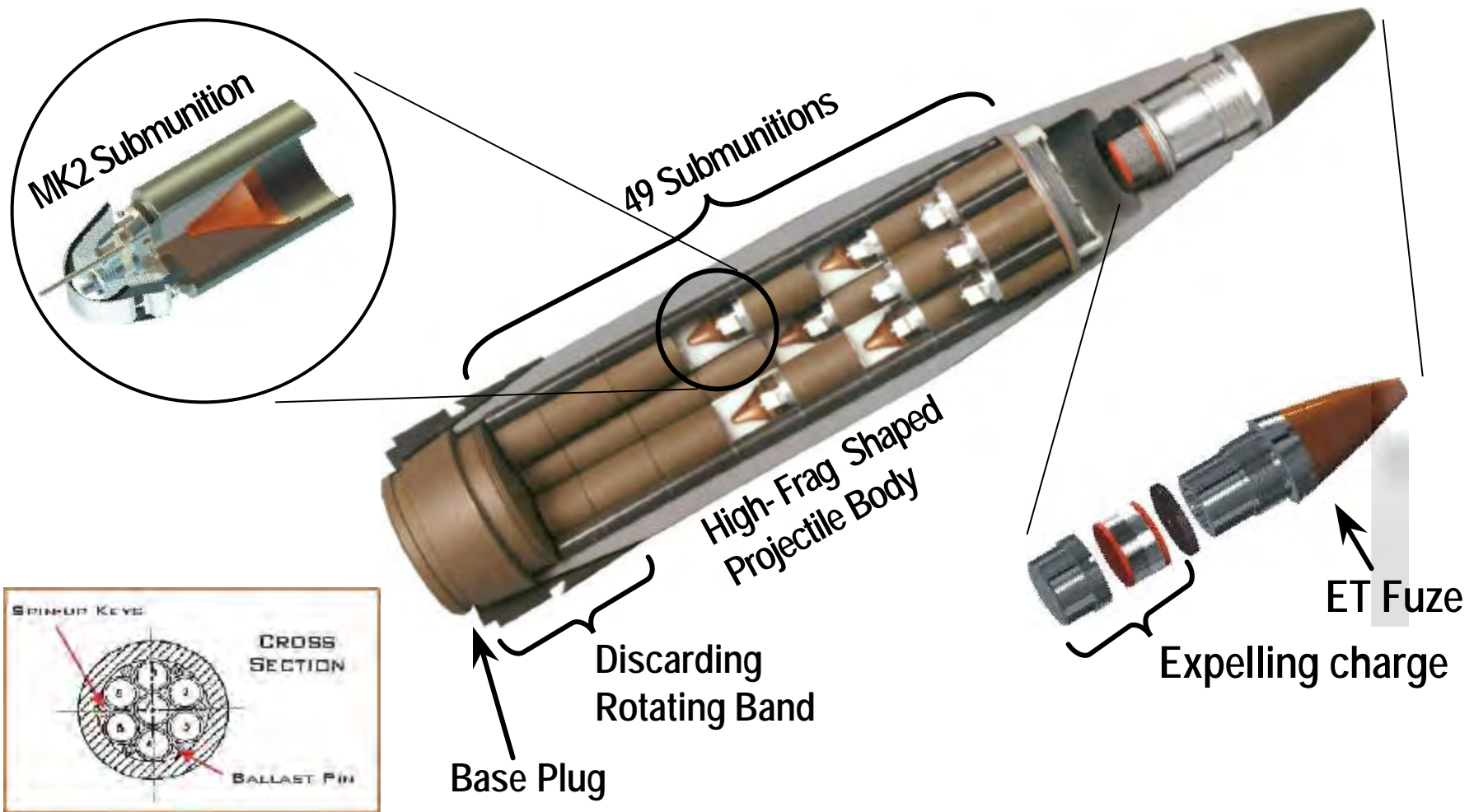

NDIA, 4/18/01, cfinch



# Fuze Alternatives

	<b>MK 429 MFF</b>	<b>Simplified MK 429</b>	<b>Modified MOFA</b>	<b>Modified M762A1</b>
<b>Development Cost</b>	<b>None</b>	<b>\$1,000,000+</b>	<b>\$1,000,000+</b>	<b>\$1,000,000+</b>
<b>Projectile Compatibility</b>	<b>Proven</b>	<b>Proven</b>	<b>TBD</b>	<b>Proven</b>
<b>Overhead Safety</b>	<b>Acceptable</b>	<b>Acceptable</b>	<b>TBD</b>	<b>Excellent</b>
<b>Unit Cost</b>	<b>High</b>	<b>Medium</b>	<b>Low</b>	<b>Lowest</b>
<b>Total Cost 14,600 Fuzes</b>	<b>High</b>	<b>High</b>	<b>Medium</b>	<b>Low</b>



# Team Approach

- Take Advantage of M762A1 MCP in Process
- Amended Army's MCP Contract on May 2000

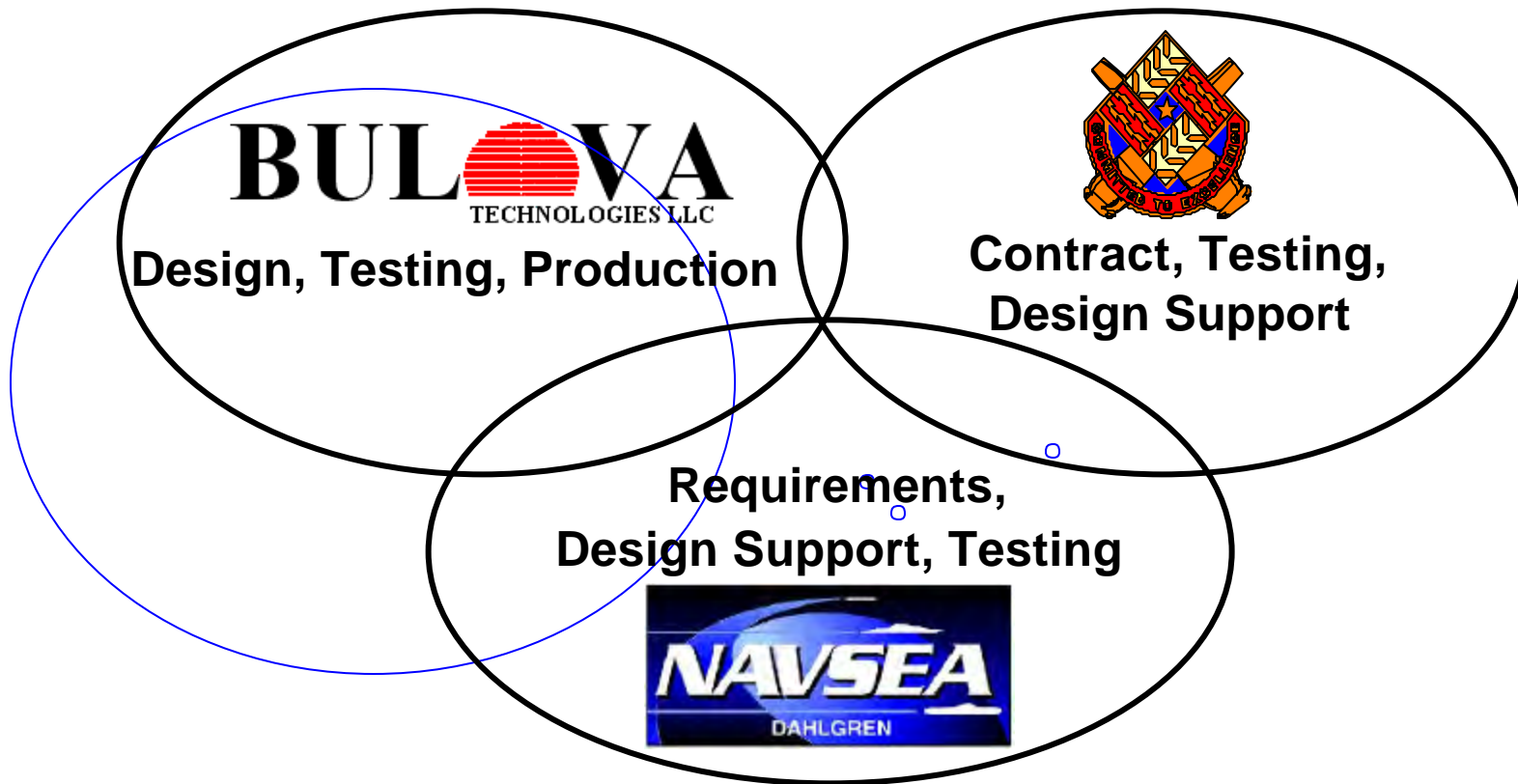



# Requirements

---

- **Three Major Changes to M762A1 Fuze:**
  - **Compatibility w/ Gun Weapon System**
    - **Inductive Set Changes**
  - **Battery Activation**
    - **From Activate on Set to Activate at Gun Launch**
  - **Targets**
    - **Increased Timer Precision**



# Inductive Set Changes

---

## M762A1

- **PIAFS Setter**
- **19 Bit Message**
- **Single Set Mode**
- **Time Resolution**
  - **0.1 Second**

## MK 432

- **MK 34 Setter**
- **26 Bit Message**
- **Continuous Set Mode**
- **Time Resolution**
  - **0.01 Second**



# Inductive Set Changes

## M762A1



## MK 432

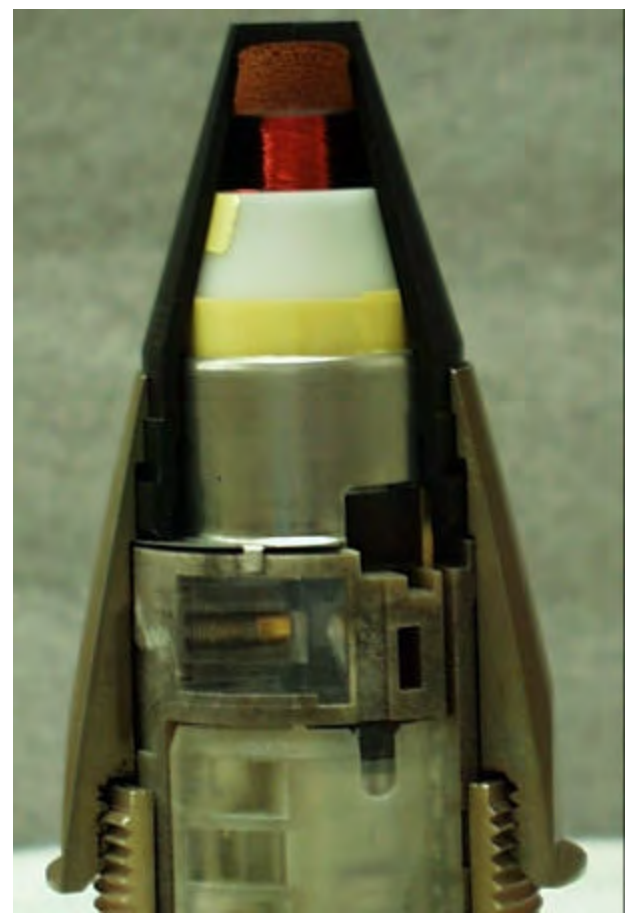



# Battery Activation

---

- **M762A1**
  - **Activation on Set (Manual or Inductive)**
- **MK 432**
  - **Activation at Gun Launch Required**
  - **Redundant Activation Methods:**
    - **Electrical Activation**
      - **Spin Switch Closure Initiates Battery Primer**
    - **Mechanical Activation**

# Battery Activation

- **Mechanical Activation**
  - **Modified Actuating Rod Release Stab Pin Via Setback Force**
  - **Stab Pin Has Less Mass**
  - **Entire Stab Assembly Lubricated**
  - **Design Proven in Vertical Recovery Tests**

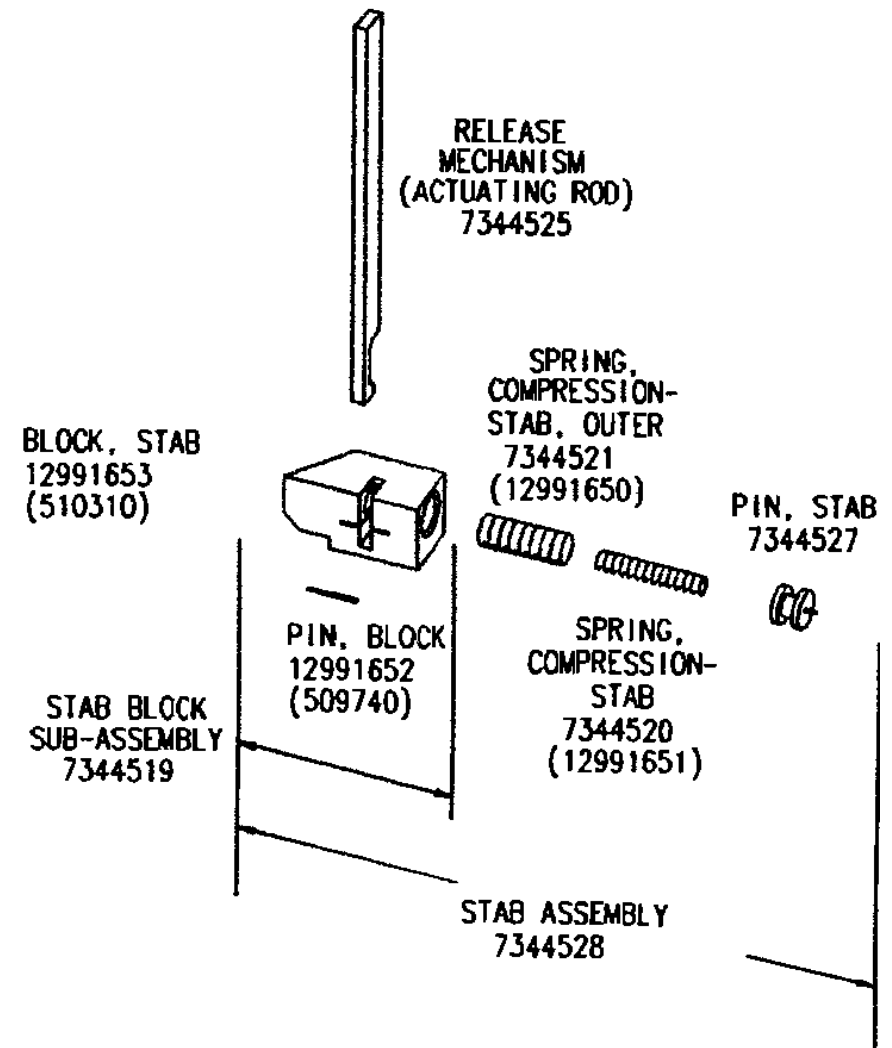



# Timer Precision

---

- **M762**
  - **Settable to 199.9s**
  - **Set Resolution of 0.1 Seconds**
- **MK 432**
  - **Settable to 327.66s**
  - **Set Resolution of 0.01 Seconds**
  - **Greater Precision Needed for SuW Targets**
  - **System Errors Reduce Benefit at Long Range**



# Other Changes

---

- **Eliminated Manual Set Capability**
- **Eliminated Point Detonating Backup Mode**
  - **MK 432 Will Dud in the Event of a Primary Mode Failure**
- **New Carbon Filled Ogive**
  - **Added Protection During Electromagnetic Environmental Effects**



# Qualification

---

- **400 Fuzes Completed on 30 March**
- **First 10 Gun Fired at Yuma on 21 March**
  - **Only 10 Months from Contract Award**
  - **9 Successful Firings, 1 No Test**
- **60 Fuzes for EEE Testing**
- **102 Fuzes for MIL-STD-331B**
- **Qualification Completed Summer 2001**



# Production

---

- **Scheduled to Begin July 2001**
- **14,600 Fuzes Delivery October 2001**
- **Old Fashion Build to Print Contract**
  - **No Performance Specification**
- **On Schedule for a Record Setting Delivery**
  - **16 Months from PIP Contract to Completion of Production**

# Fuzing for Global Interoperability

---



- **Cockpit Programming to Reduce Logistics**
- **Distributed Arming Systems for Missiles**
- **Tolerant Burst Point Control**

# Future Cockpit Programming

---



## Present programming

- Mission planning tools program a PCMCIA card
- PCMCIA card sent to fuze programming site or Mission data sent to fuze programming site and program a PCMCIA card
- Setter unit programs fuze on ground
- Fuze's program checksums hand written on weapon
- Weapon loaded onto specific location of aircraft
- In-flight, fuze mission data can be reprogrammed
- Pilot selects proper weapon from aircraft stores
- Launch weapon

## Future programming

- Mission planning develops mission data
- Mission data sent to aircraft
- Aircraft programs fuze, including weapon type
- Launch weapon

# Cockpit Programming Improvements

---



- **Reduce Tactical Response Time by eliminating Ground Programming Processes**
- **Increase Reliability of Launching Proper Weapon from Aircraft. Prevent Launching Weapon with Wrong Mission Data at a Target, when can't Interrogate Weapon on Aircraft**
- **Eliminate Hardware, I.e. Ground Setter Unit**
- **Eliminate Training, I.e. Ground Setter Unit Training**
- **Eliminate Maintenance I.e. Ground Setter Unit Maintenance**
- **Increase Fuze Connector Life and Reliability**
  - **Reduce Number of Connections to Fuze**

# Cockpit Programming Plan

---



- **Develop System Safety Approach to program Mission and Weapon Type Parameters**
- **Obtain Safety Board Approval of Approach**
- **Implement Approach**
- **Obtain Safety Board Approval of Design**

# Distributed Arming Systems

---



- **Reason for a Distributed Arming System**
  - **Fuze does not have access to Arming Environments, like when Fuze is buried in a Missile**
- **Core Requirements for Distributed Arming System**
  - **MIL-STD-1316 requires Two Independent Arming Environments that Independently Control Arming**
    - **Hardware only (No Software) in at Least One Arming Environment Path**
  - **Unique Code for Arming**

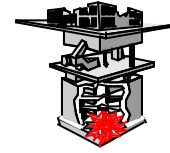

# Examples of Distributed Arming Systems

---

- **Free-Flight and Guided Bomb Systems**
  - **FMU-139 and FZU-48**
  - **FMU-152 and FZU-55**
  - **HTSF and FZU-60**
- **BAT: Umbilical Separation, Air Stream Sensing, and ESAD**
- **TTPV with a HTSF**
- **CALCM with a HTSF**
- **Others**

# FZU Distributed Arming Systems

---



- **FZU detects Two Independent Arming Environments**
  - **Lanyard Pull**
    - **Minimum Lanyard Pull Force**
    - **FZU Time Windows the Turbine Release Arming Environment**
  - **FZU Powers Fuze with Post Launch Air Stream**
- **Unique Power & Turbine Release Signals from FZU-48 & FZU-55**
  - **Positive for Power**
  - **Negative for Turbine Release**
- **FZU-60 Power and Turbine Release Frequencies verified with HTSF & MEHTF**

# Missile Distributed Arming Systems

---



- **Missile programs Fuze**
- **Missile detects Arming Environments**
- **Missile builds Unique Arm Code with Arming Environment Data**
- **Missile provides Arming Power to Fuze**
- **Missile provides Unique Arm Code to Fuze**
- **Fuze arms after**
  - **Timing out Arm Time**
  - **Detecting Unique Arm Code**

# Unique Arm Code



- 
- **Probability of Occurrence << One in a Million to meet MIL-STD-1316's Less than One in a Million arm before launch for System**
  - **Ignores Common signals**
    - Common power: DC, 110Vac. 60hz; 110Vac, 400hz
    - Low Frequency Guidance Signals
  - **Provides Immunity to Electromagnetic Environments**  
(HERO, EMV, Other)
  - **Built using arming environments like**
    - Launch
    - Deployment of Air Surfaces
    - Post Launch Air Stream or Engine Power
    - Other

# Tolerant Burst Point Control

---



- **Void Detection of HTSF and MEHTF provide Accurate Depth of Burial for**
  - **Varying Overburden**
  - **Multiple Voids**
  - **Unknown Void Lengths**



# HTSF & MEHTF Void Burst Point Control

- Void depth of burial makes target defeat economical with Tolerant burst point control
- DOB from void entry fires warhead in void without accurate target intelligence
  - Prevents fires before and after voids
  - Reduces DOB errors from variations in overburden, impact angles, angle of attack, impact velocity, and warhead turning during penetration

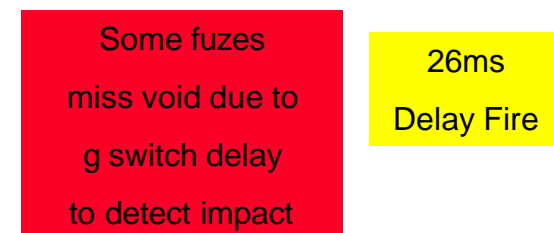
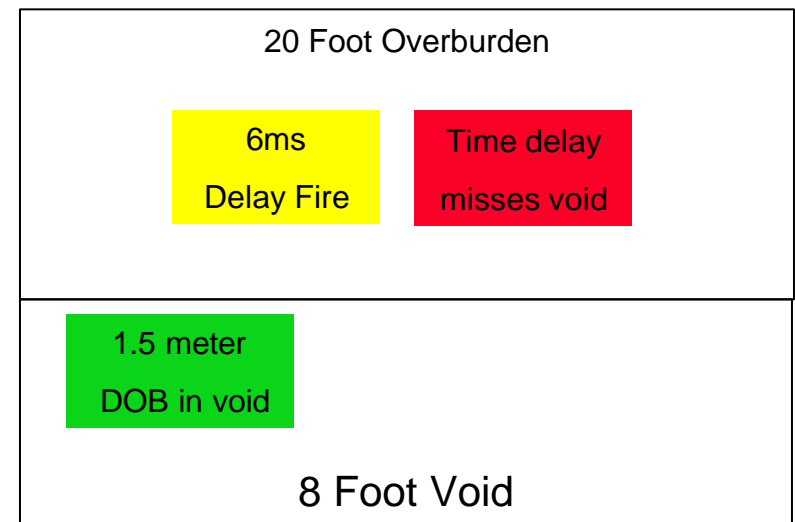



# **Air Bursting Munition ABM Medium Calibre Applications**

Allan Buckley & Pierre Freymond  
Oerlikon Contraves Pyrotec AG  
CH-8050 Zurich / Switzerland  
[ocp-marketing@ocag.ch](mailto:ocp-marketing@ocag.ch)

# ABM Fuze Components

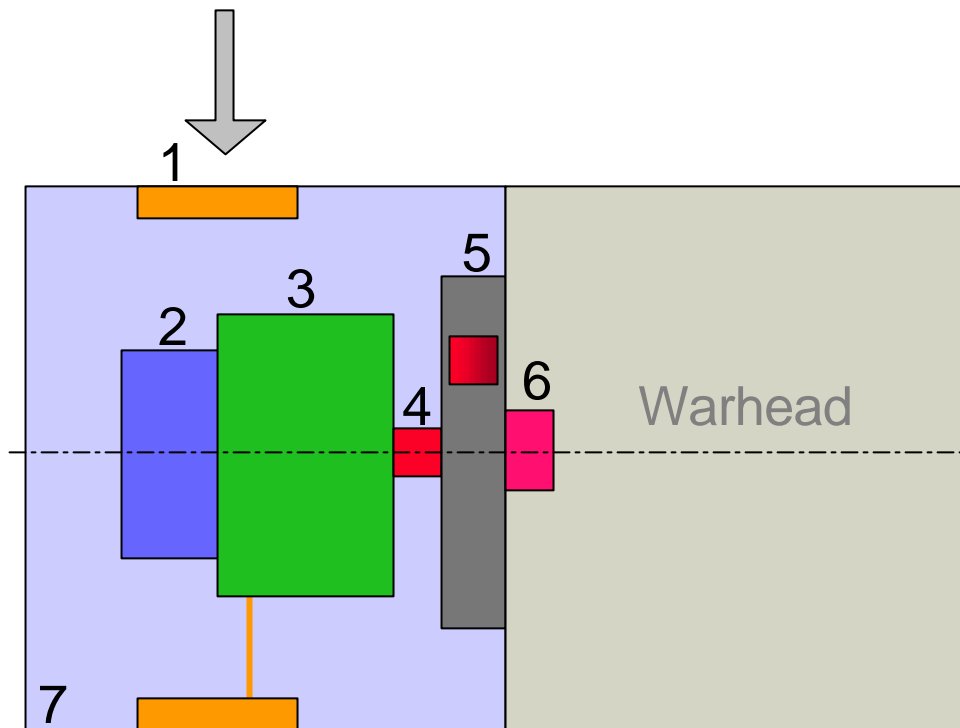

↑ Contactless  
Programming  
at Gun Muzzle

Fuze Components:

1 Receiving Coil

2 Setback Generator

3 Electronic Timer  
Module

4 Squib

5 Safe & Arm

6 Booster, Ejection Charge

7 Base-Fuze Housing



# ABM Programming System With On-Line Compensation of MV-Variation

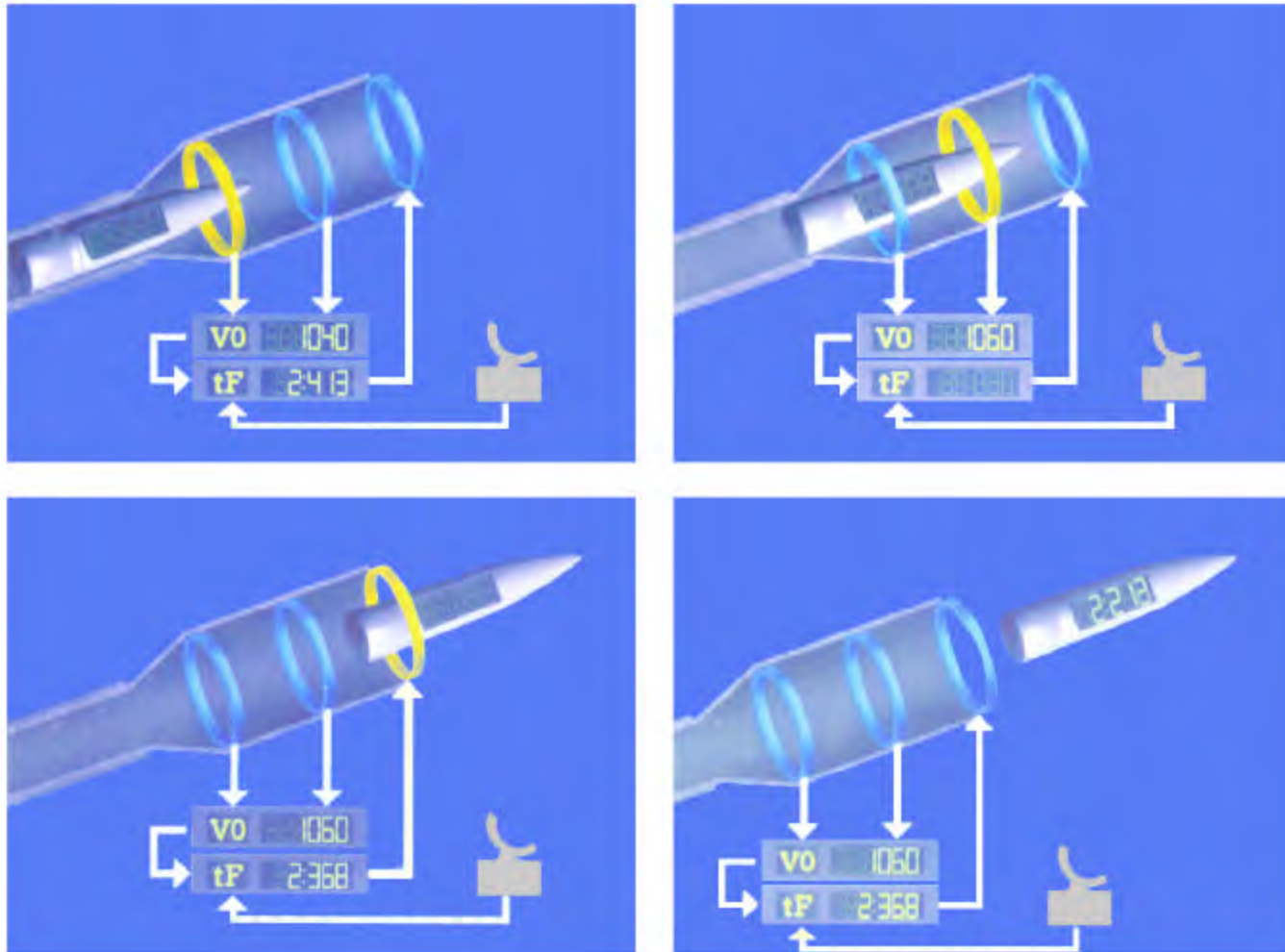

# ABM KETF

## Subprojectile Payload Delivery

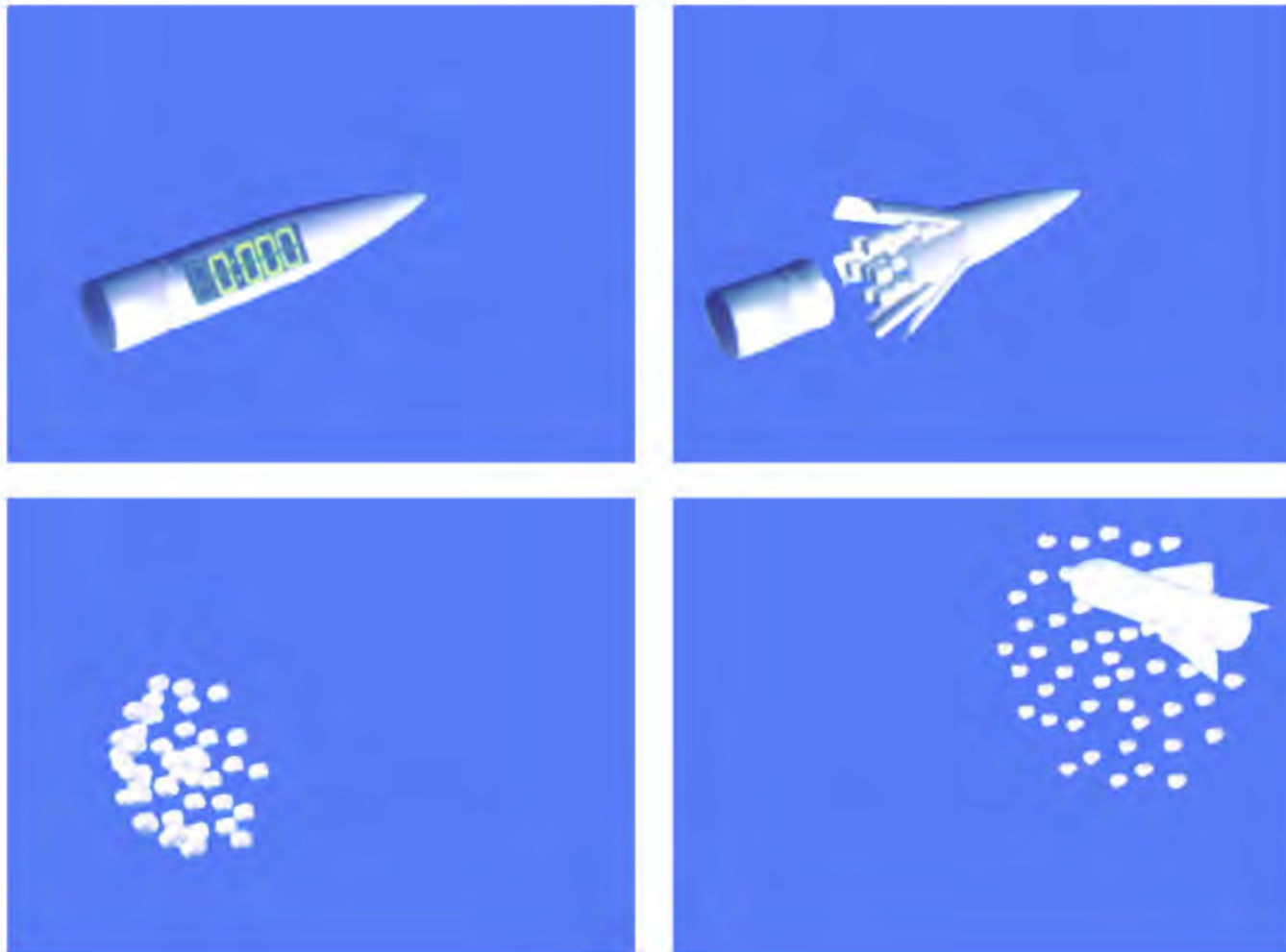

# Fuze Challenge!

## Programmable Payload Delivery

Precise Time Space Payload Delivery up to 5000 rd/min!

10 Rds between 1200 m & 300 m  
every 100 m!



10th Rd:  
300 m

1st Rd:  
1200 m



„String of Pearls“ at 550 Rd/min of 35mm Ahead-HETF Ammunition

# Fuze Programming without & with Compensation of Muzzle Velocity Variation



7 Rd Burst 35mm Ahead-HETF Ammunition at 1600 m Range

# ABM Family of Oerlikon Contraves

35mm x 228  
Ahead  
NATO Qual.



30mm x 173  
selected for  
AAAV - FCT



40mm x 53  
selected in  
Sweden for  
evaluation



Other studies on  
following calibers:  
25mm x 137  
27mm x 145  
up to 140 mm

# One ABM Fuze System (Ahead) - Two Different Warhead Systems

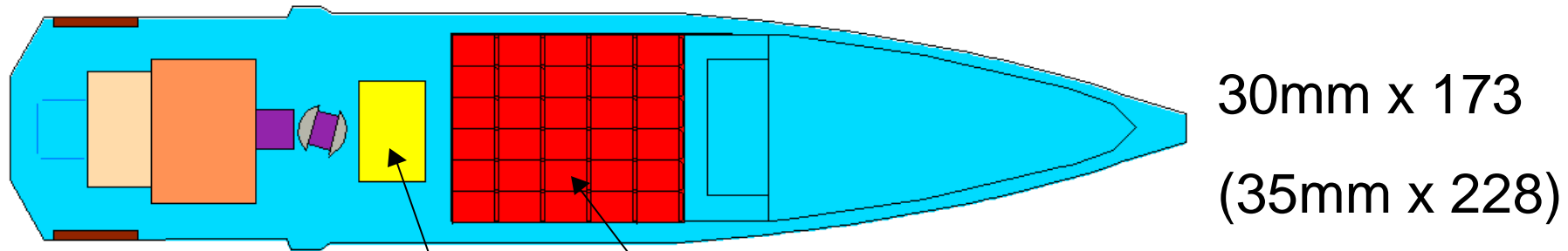

Ejection  
Charge

**Subprojectile Warhead  
(KETF: Kinetic Energy Time Fuze)**

Programmable  
Base Fuze

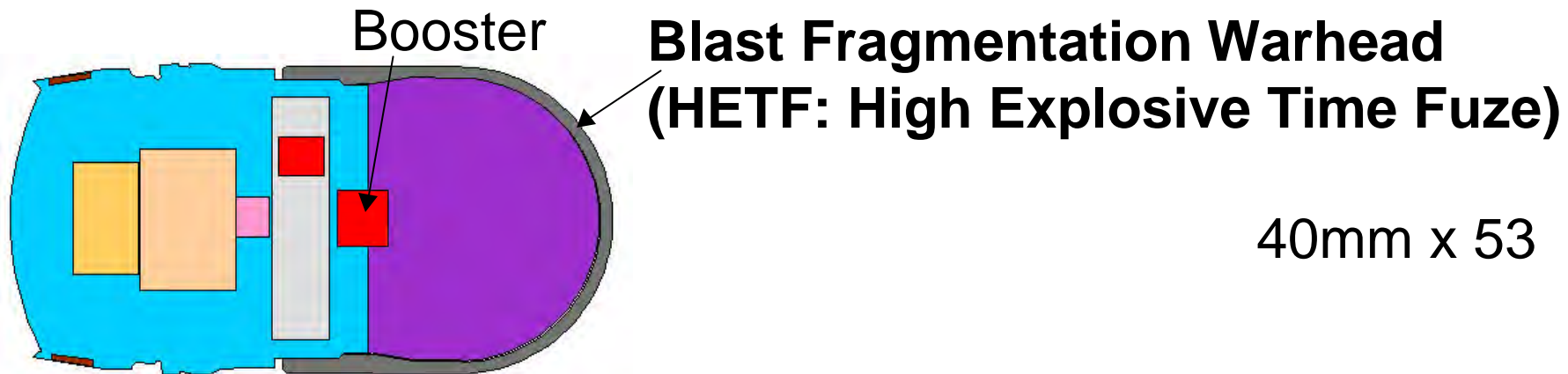



# ABM KETF

## Subprojectile Payload Ejection

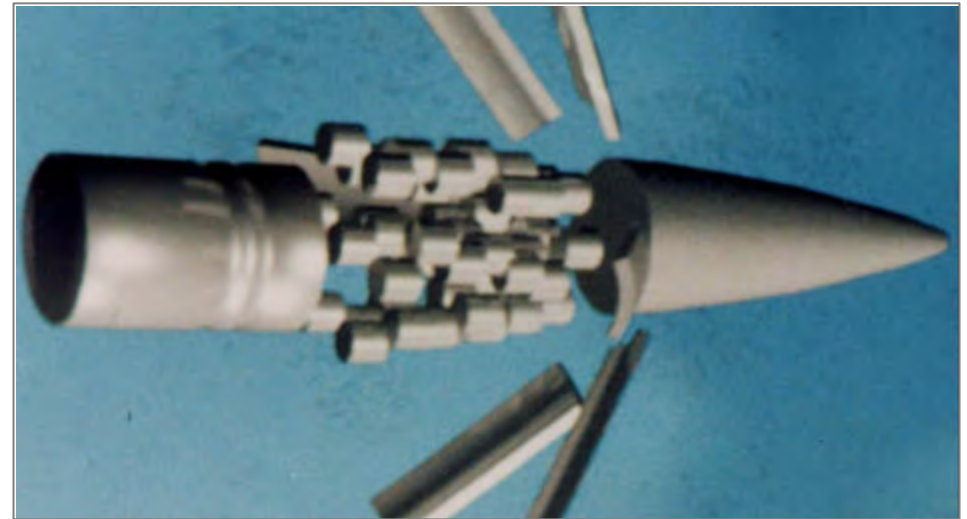
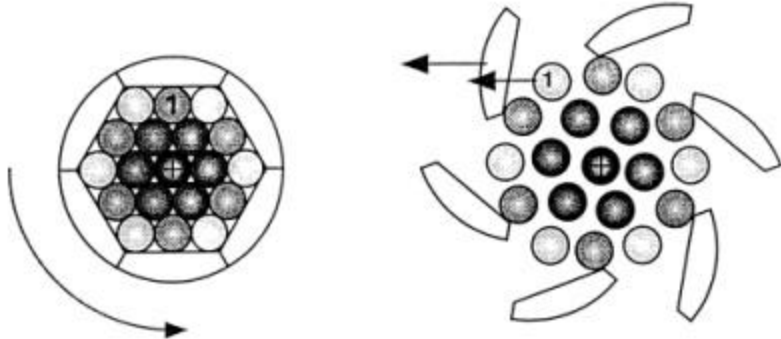
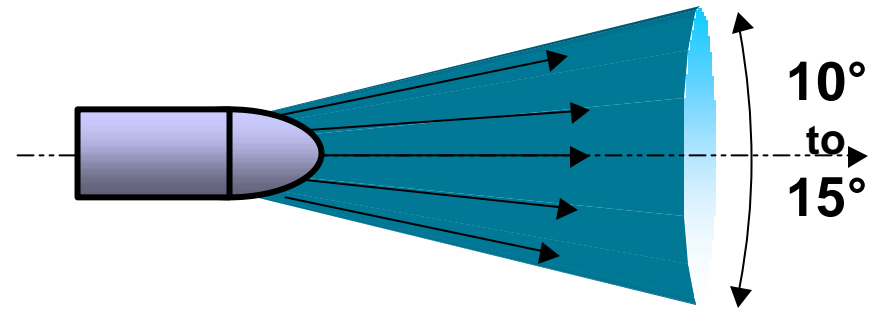

# ABM KETF 30mm x 173 Payload Ejection Dynamics

135 Subprojectiles at 1.5 g each

5 Layers at 27 Subprojectiles

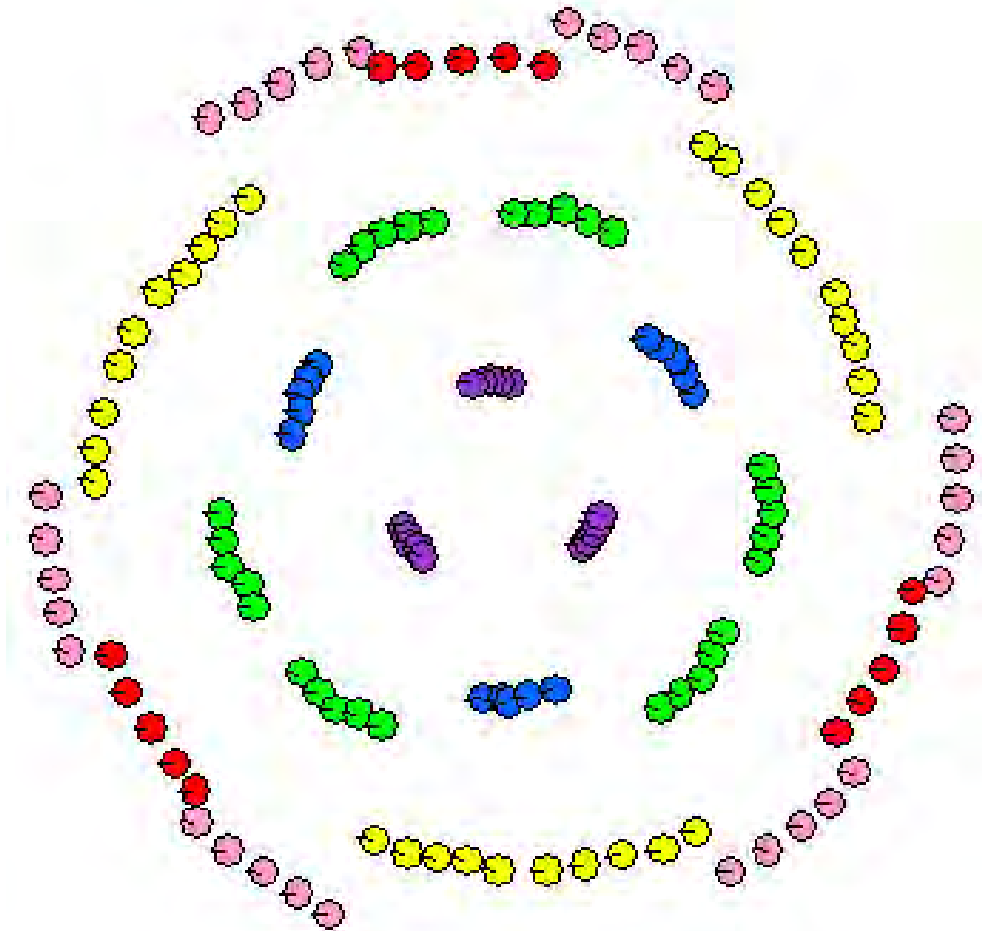
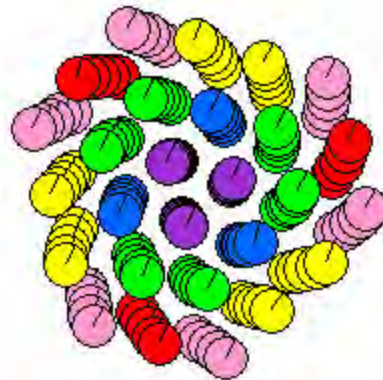
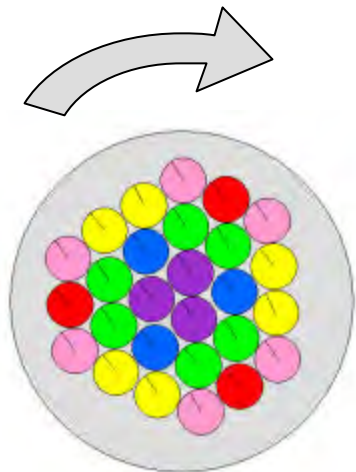

Time: 0  $\mu\text{s}$

100  $\mu\text{s}$

500  $\mu\text{s}$

# ABM KETF 30mm x 173 against ATGW-Bunker at 1 Km Range

Results: Numerous Full Perforations/100% Damage (Demo: Dec.1999)



# ABM (KETF & HETF) 35mm x 228 against ATGW-Bunker

Lethality of a  
3 Rd Burst  
against an  
ATGW Bunker  
at 1500 m

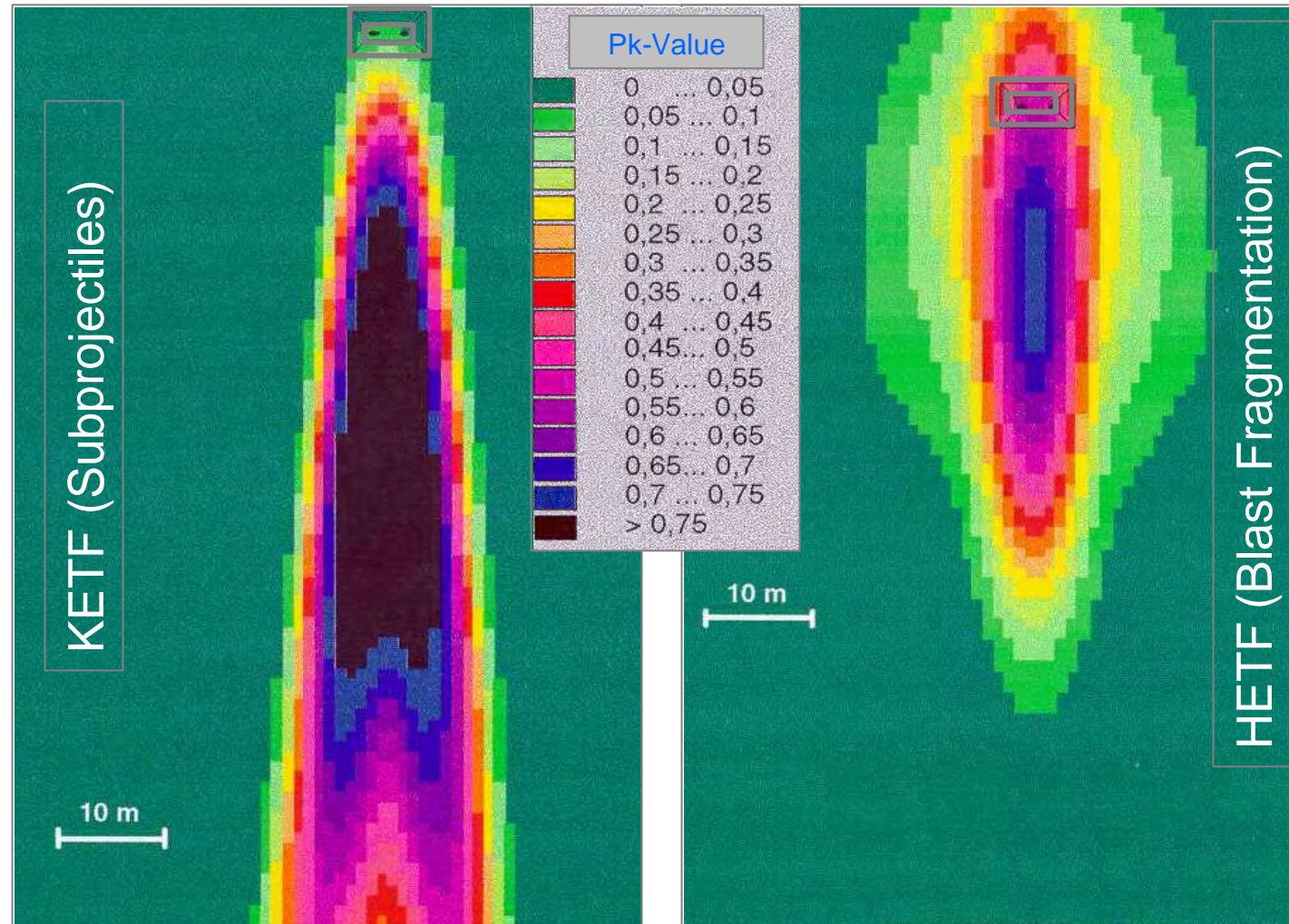

# ABM KETF 30mm x 173 against Urban Target (Unprogrammed Fuze)

Target: 20 cm Concrete Wall with double Steel-Structure Reinforced  
Results: Target Fully Penetrated



# ABM KETF 35mm x 228 Ahead Simulated Lethality > 2 km Range

Target: Maverick Missile

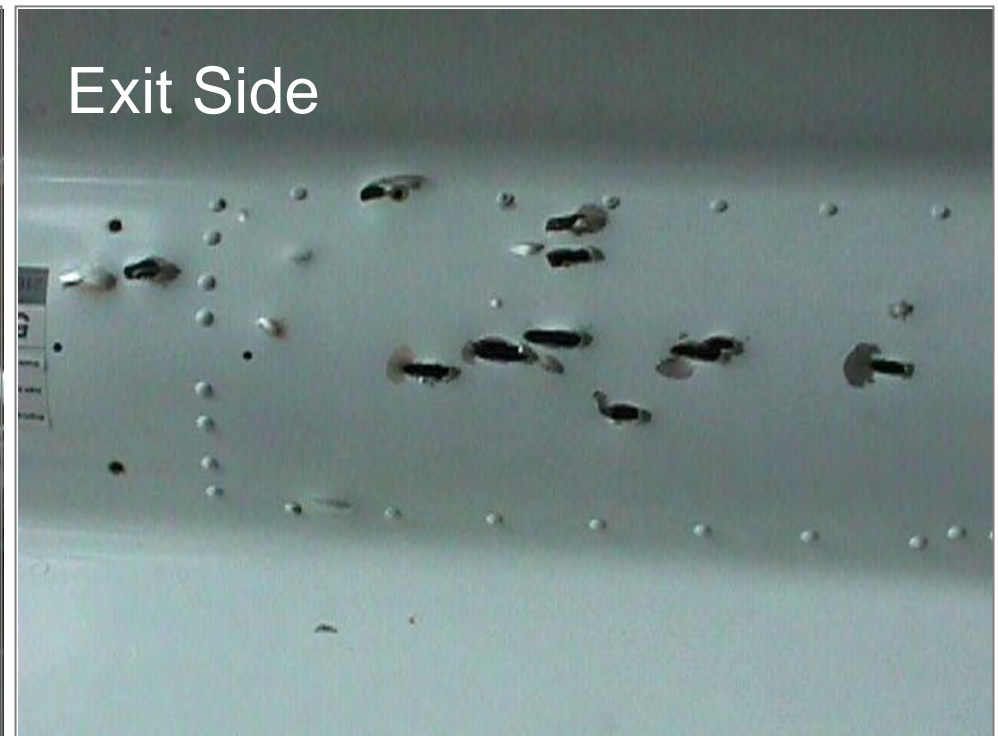

Subprojectile Graze Angle Impact <math>< 10^\circ</math>

# ABM HETF Basic Concept for 40mm x 53 Automatic Grenade Launcher AGL

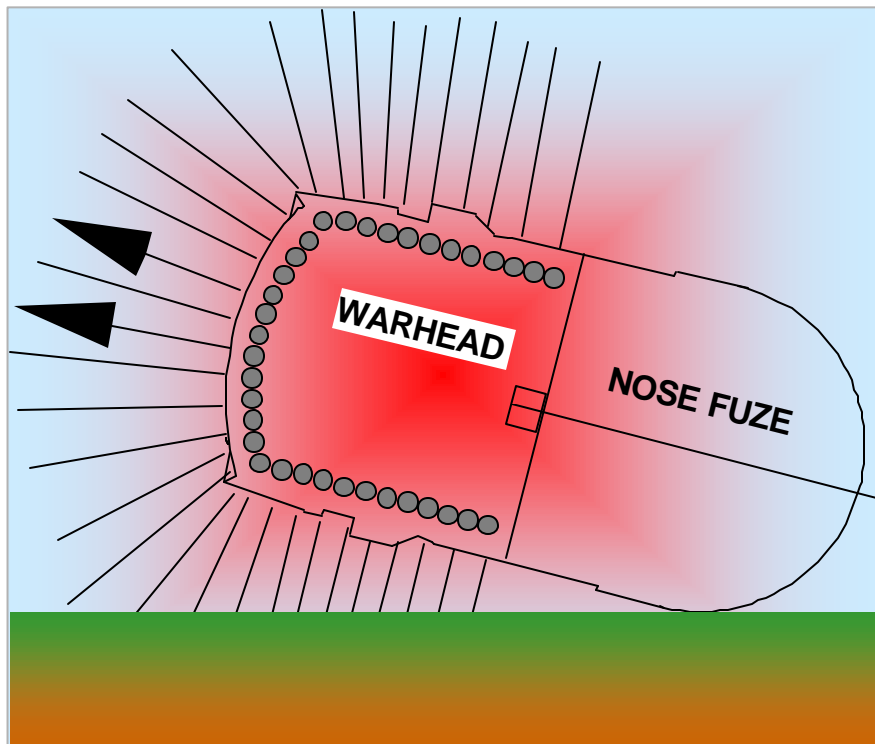

Conventional HE Round  
(PD-Fuze)

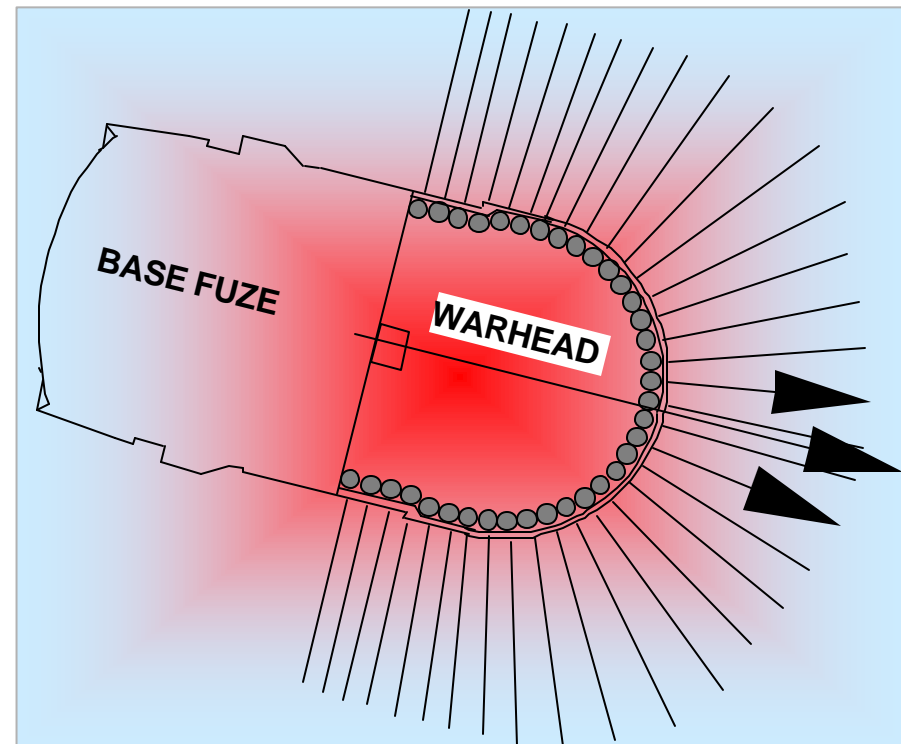

Optimum for  
Air Burst Munition

TARGET

# ABM HETF 40mm x 53 for AGL

## Round Parameters

• Round Length	max. 112 mm	
• Round Volume	approx. 130 cm <sup>3</sup>	
• Round Mass	350 g	
• Projectile Mass	245 g	
• High Explosive Mass	> 35 g	
• Muzzle Velocity	245 m/s	
• Time of Flight	500 m	2.3 s
	1000 m	5.3 s
	1500 m	9.3 s
	2000 m	15.3 s

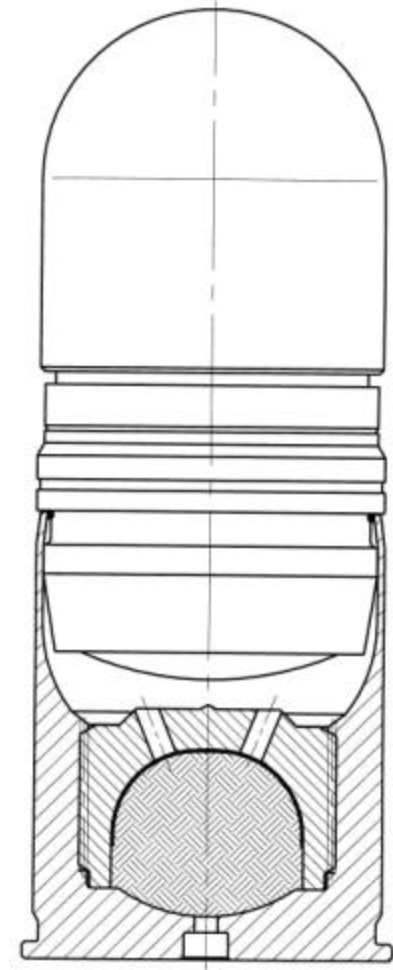

# ABM HETF 40 mm x 53 Muzzle Programming Device

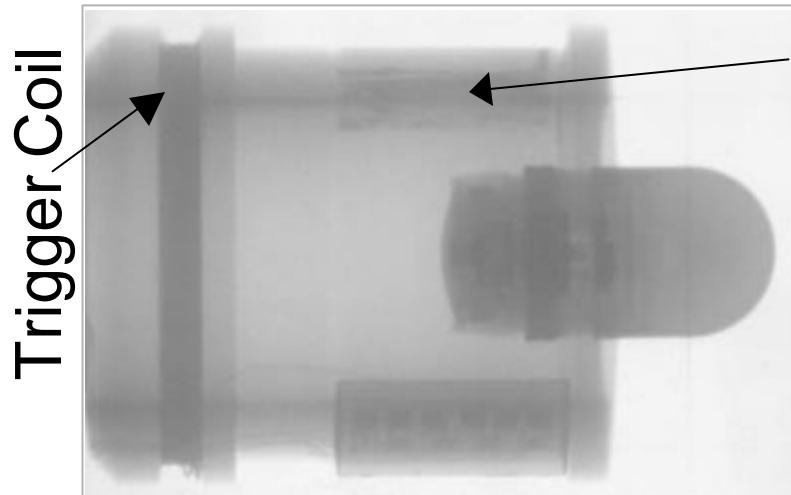

Programming Coil

Ammunition Programming Phase in  
Muzzle Programming Device

(X-Ray Picture)

Ammunition Programmer & Projectile

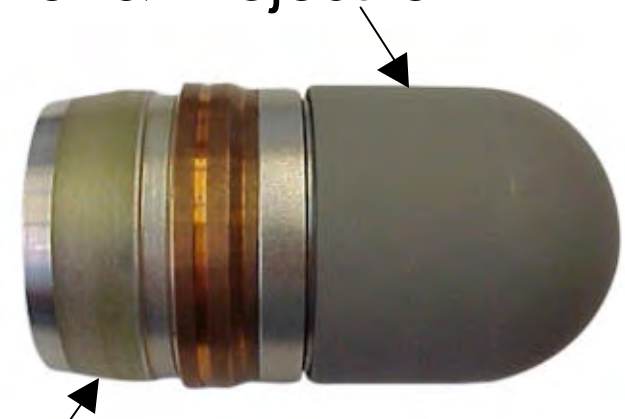
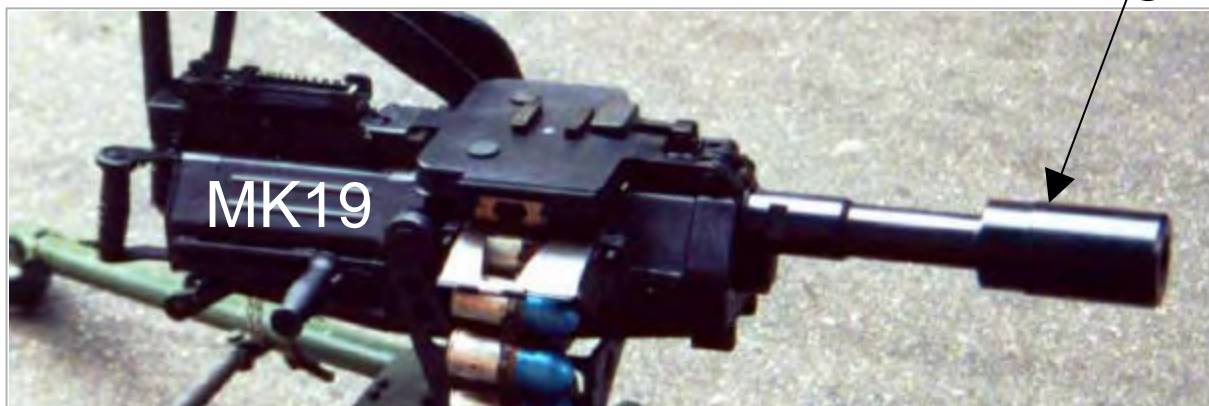

Receiving Coil

# ABM HETF 40 mm x 53 Firing Trials

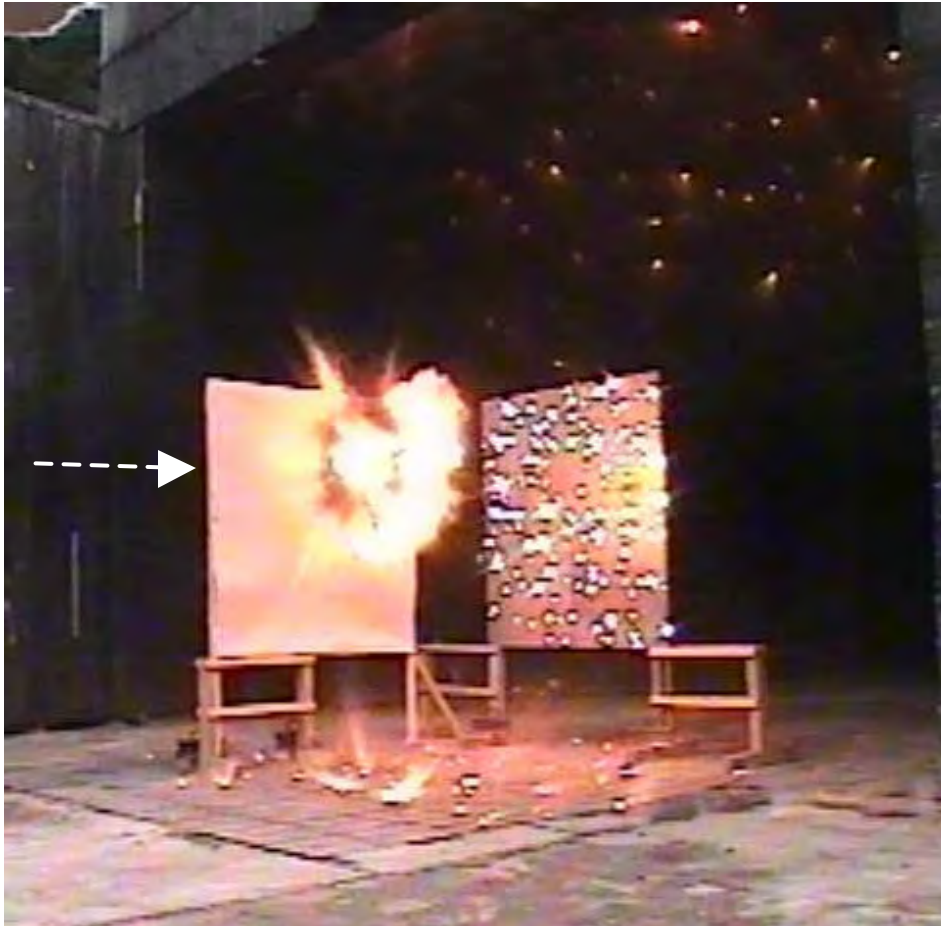

Range 200 m



Range 1000 m



# ABM Fuze (Ahead): Main Features

- 1 Total modularity of components: easy manufacturing, testing & assembly
- 2 Autonomous power supply (no battery, no storage problems)
- 3 Allows rapid new fuze developments (recently: 30 mm x 173 & 40 mm x 53)
- 4 Fuze running time temperature compensated
- 5 Each bit programmed with double pulse
- 6 Completeness check on programmed message
- 7 Reliable component functions at very high g launch (> 100'000 g)
- 8 Absolutely ECM safe
- 9 Applicable to all calibers 25 mm upwards, rifled or smooth bore
- 10 High calculated system reliability (> 97%) confirmed by years of experience



# ABM System (Ahead): Main Advantages

- 1 Smart technology simple and safe in use
- 2 No rate of fire limitation due to fuze programming
- 3 Inductive fuze programming at muzzle (not in the gun)
- 4 On-line compensation for muzzle velocity variation
- 5 Easy system upgrade: no weapon modification
- 6 Absolute gun unload safety
- 7 Insensitive to mud, humidity & other environmental factors
- 8 Firing through bushes (impact sensor switched off)
- 9 If no fuze programming required, self-destruct automatically on
- 10 Lethality level of each round adjustable



# ELECTRONIC DESIGN FOR XM784/XM785 MORTAR TIME FUZE

PRESENTED TO THE NDIA FUZE SYMPOSIUM  
APRIL 18, 2001

TOM WALKER  
ANDY LESHCHYSHYN



Tank-automotive & Armaments COMmand

# INTRODUCTION TO IN-HOUSE EFFORT

- Electronic design
- Schematic
- Breadboard
- PWB
- Software
- Battery
- LCD
- 2nd environment

# MORTAR TIME FUZE

- Hand-settable
  - ogive inc/dec switch
  - enter switch
  - backlight LCD
- 5 - 99.9  $\pm$  0.1 sec
- Dual micros
- Dual XTAL timebases
- EEPROM data recorder
- Built in test (BIT)
- Dual watchdog timers
- 30 day battery life
- Sleep mode
- Inductive set
- EOD batt discharge
- PD backup



# ELECTRONICS

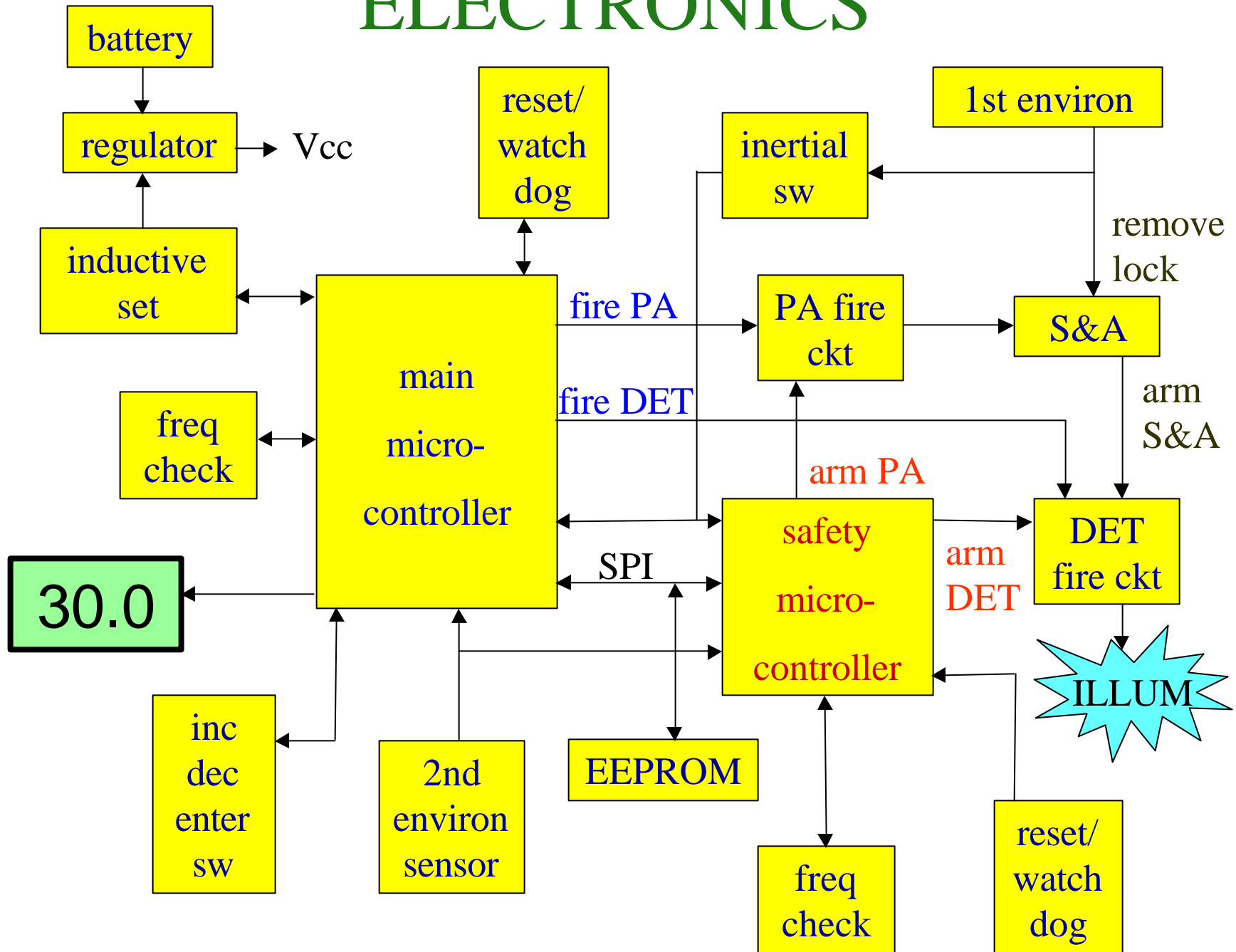

# CUSTOM BREADBOARD

- PWR & GND plane
- Surface mount IC footprints
- Two PIC emulators

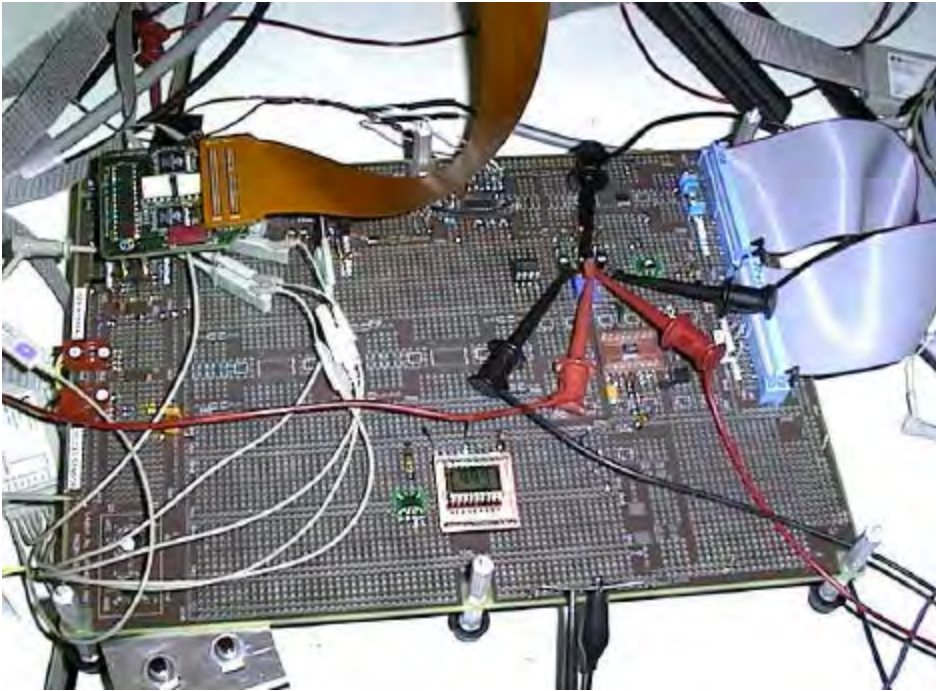

# PROTOTYPE PWB

battery, inc/dec sw interface

2nd environ.

regulator

safety micro

inductive

main micro

LCD

fire ckts

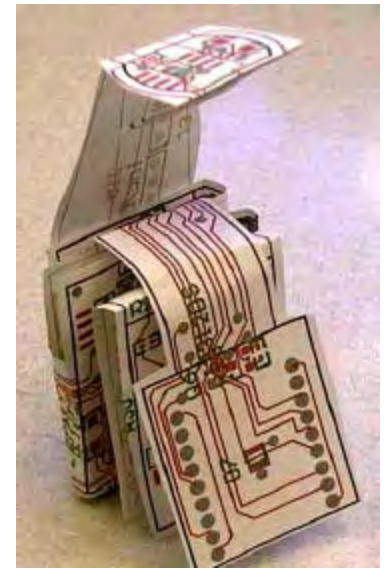

# CROSS-SECTION VIEW

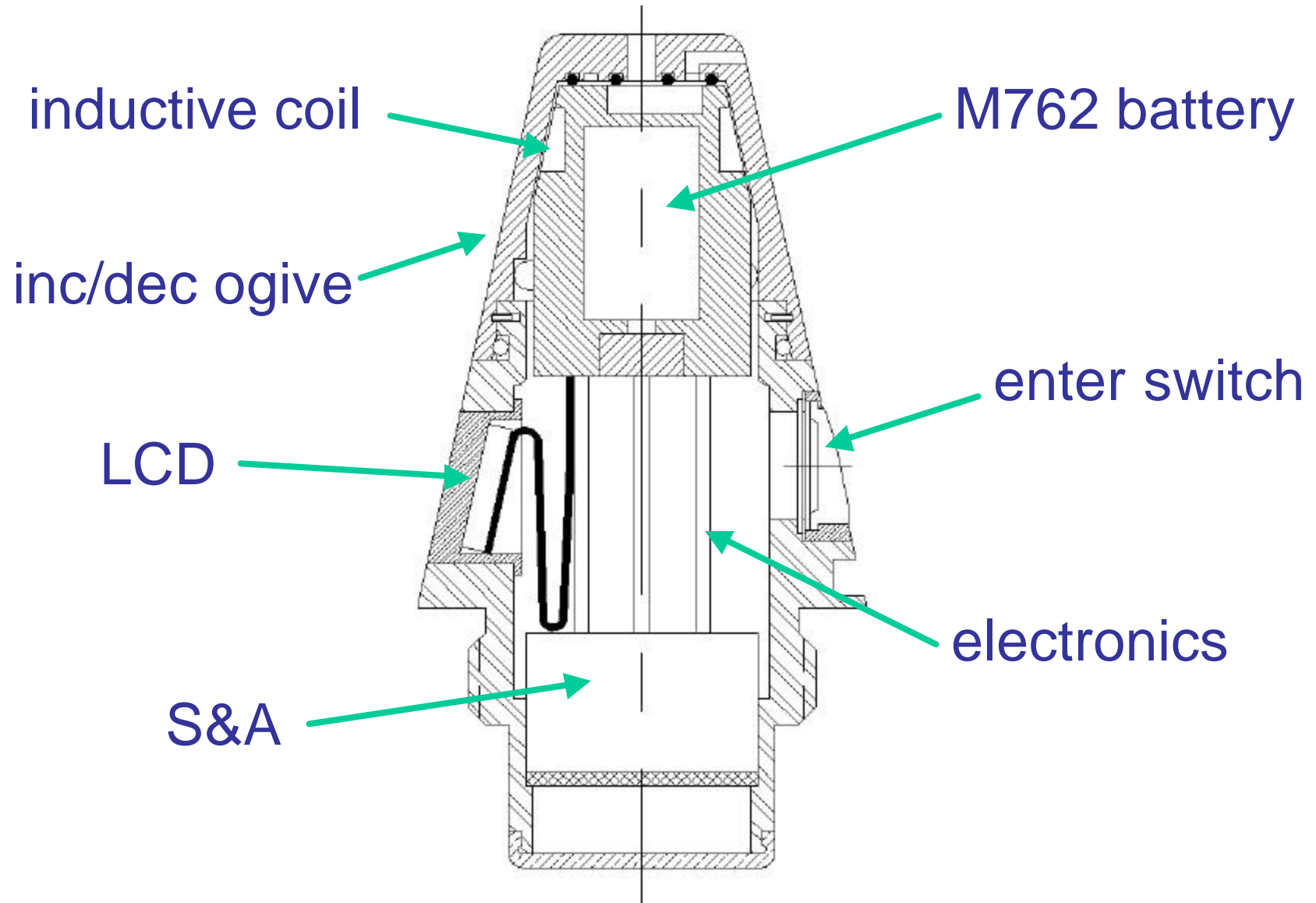

# SOFTWARE DEVELOPMENT



# MAIN FLOWCHART

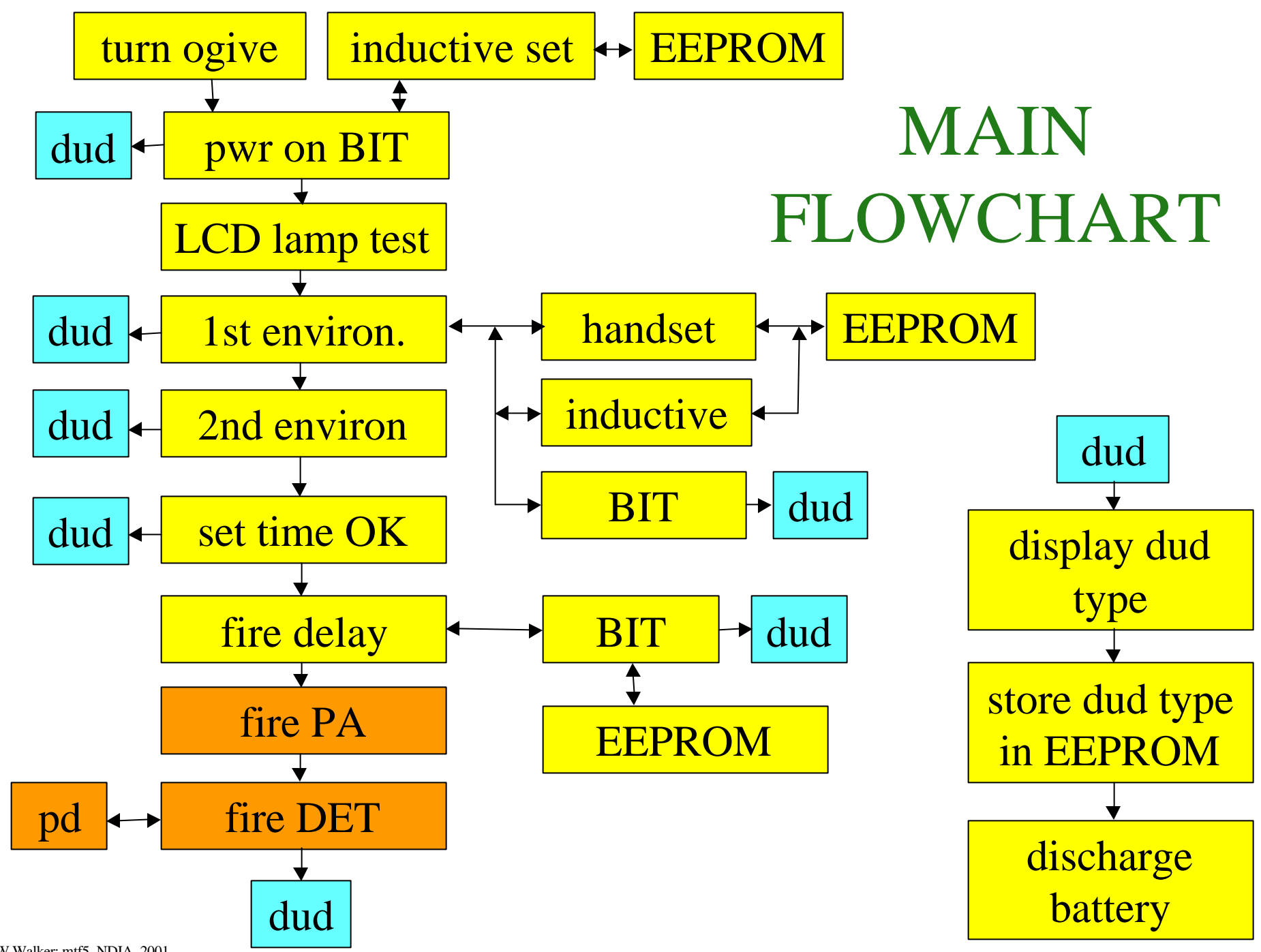

# SAFETY FLOWCHART

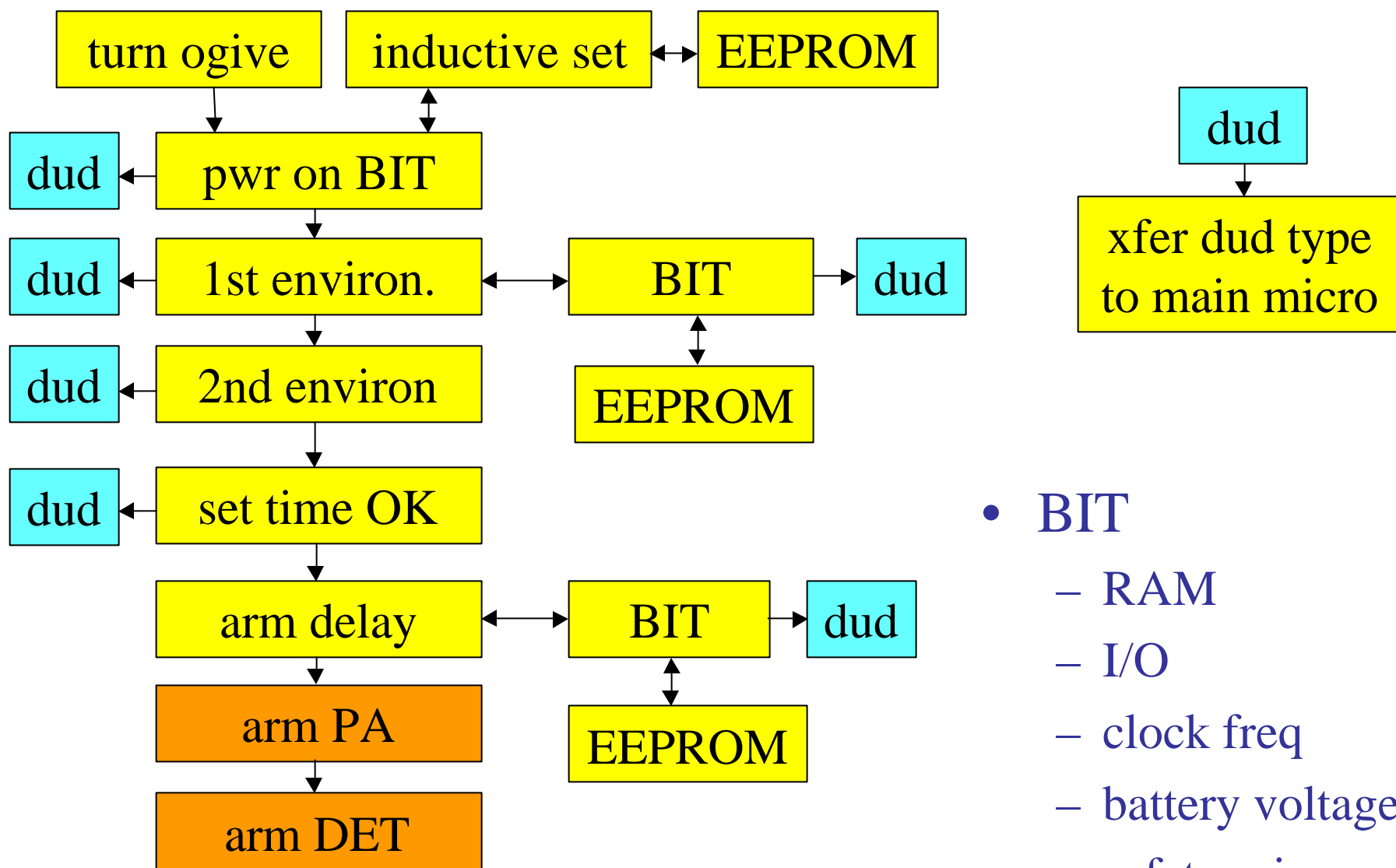

- BIT
  - RAM
  - I/O
  - clock freq
  - battery voltage
  - safety micro

# POWER CONSUMPTION

- Electronics
  - 33 mW active
  - 0.5 mW sleep
- Backlight = 7 mW
- 2nd environment
  - 45 mW gun muzzle
  - 5 mW pressure
- Fire ckts = 1 mW

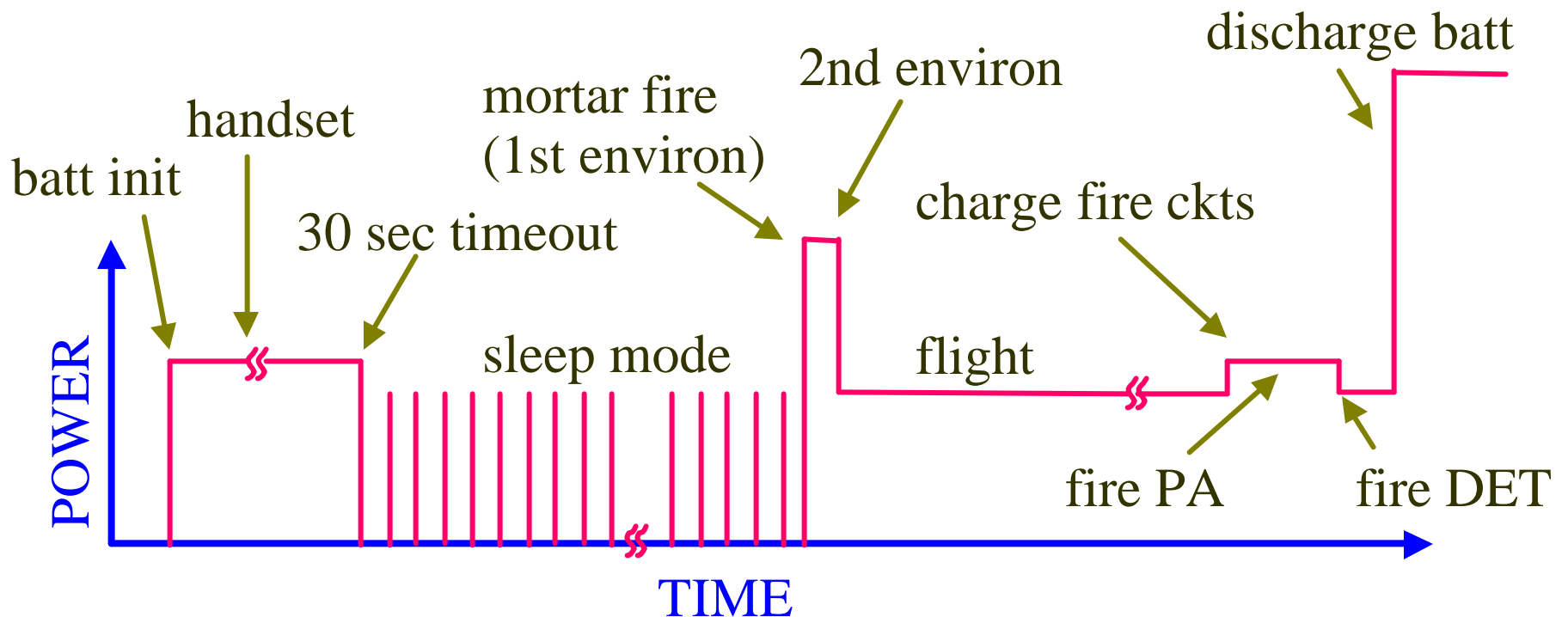

# BATTERY

- 3 day requirement
- M762 battery
- 3.6 volt lithium thionyl chloride

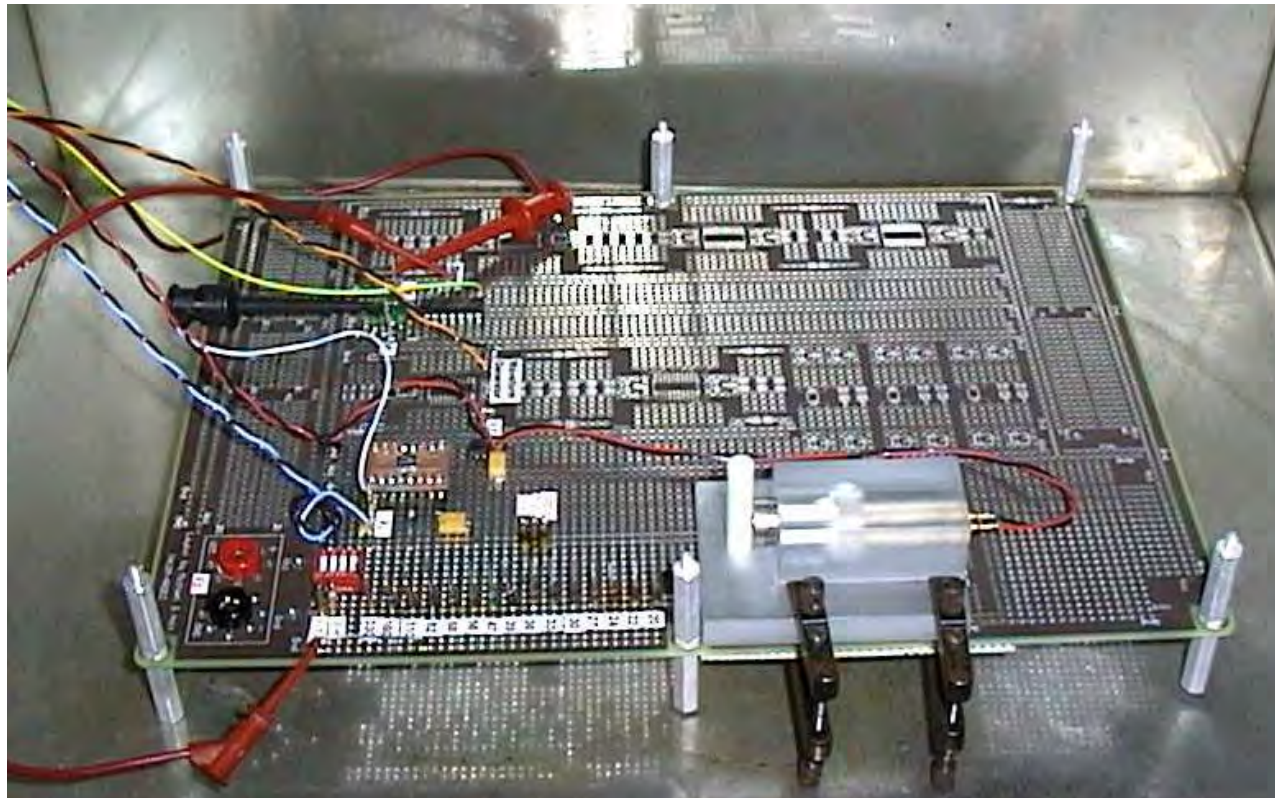

# BATTERY TESTS

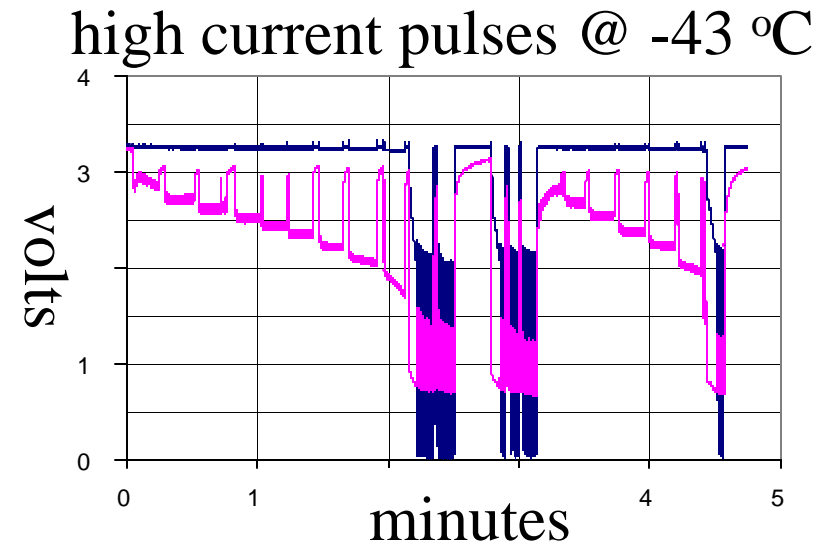
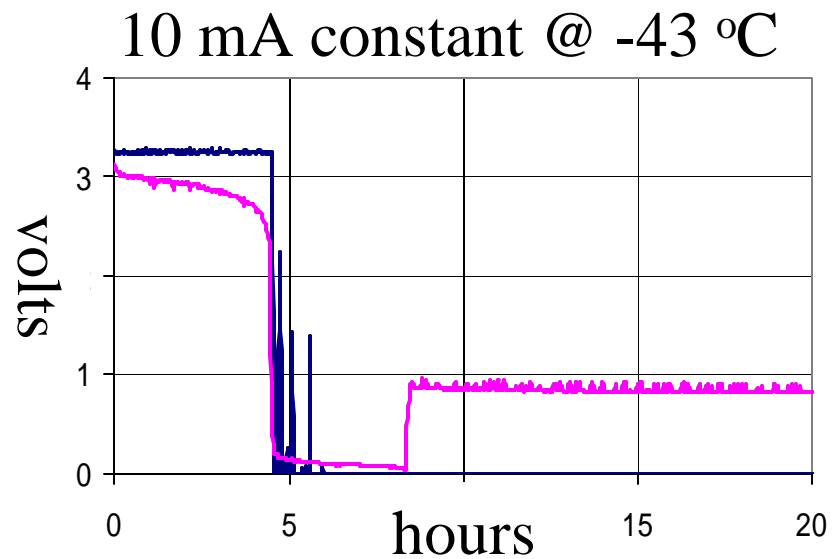
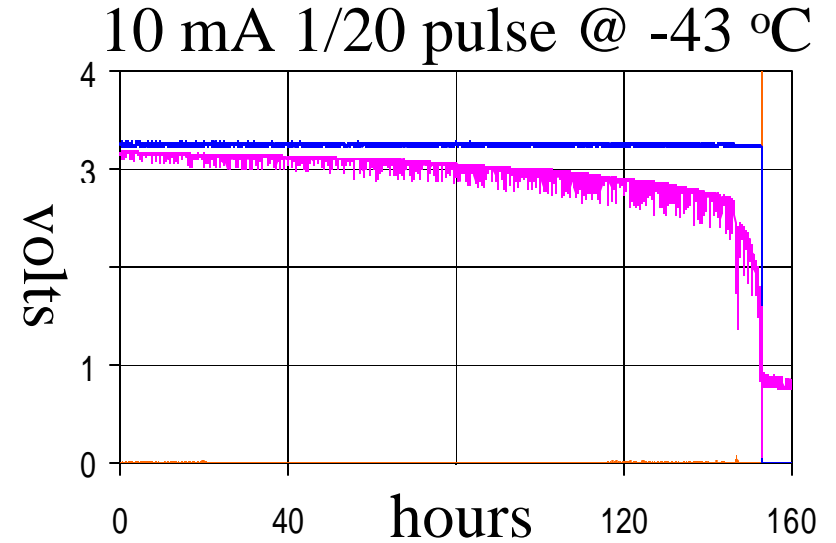
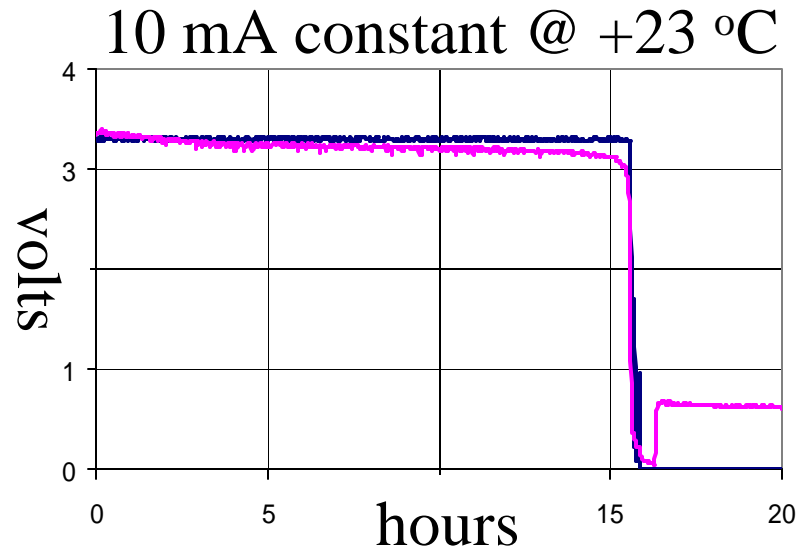

# BATTERY TEST RESULTS

actual			
TEST	TEMP (°C)	TIME (hrs)	CAPACITY (mA hrs)
10 mA constant	+63	17	170
10 mA constant	+23	15	150
10 mA constant	-43	5	50
10 mA @ 1/20 duty cycle	-43	150	75
10 mA @ 1/10,000 duty cycle	-43	3,125 days	75
extrapolated			

# LCD

- 2:1 multiplex
- Adj backplane voltage over temp
- PWM backlight: 30 sec turnoff
- M762 derivative

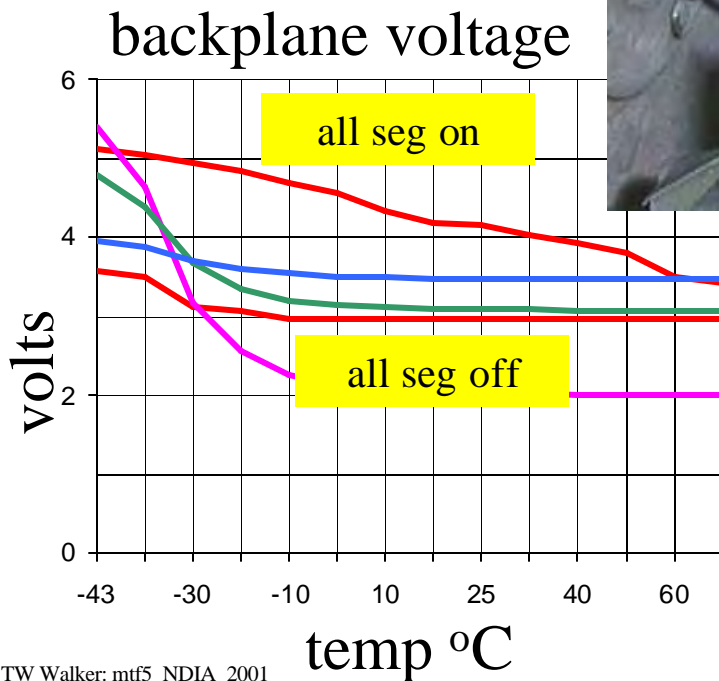
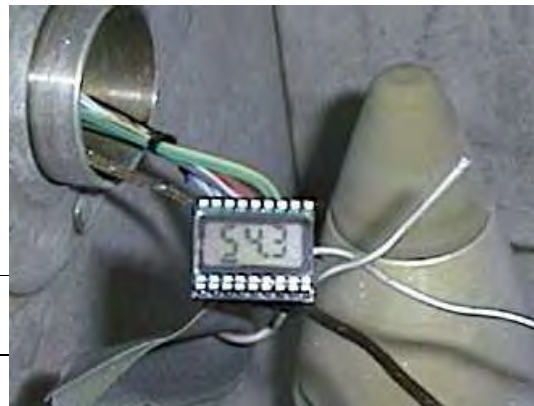
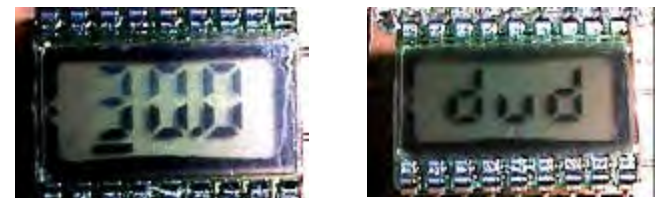
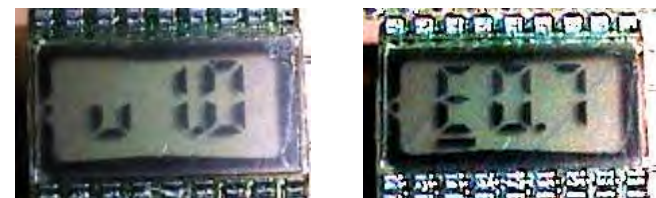
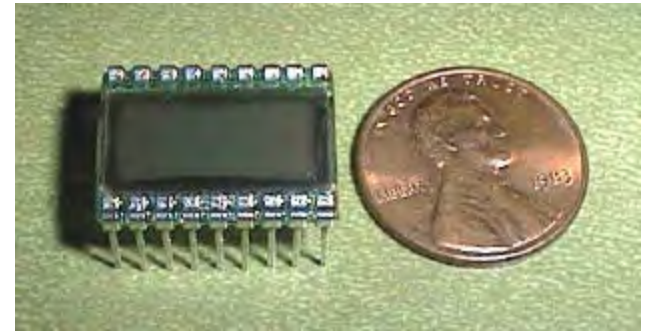

# 2nd ENVIRONMENT

- Gun muzzle exit sensor
  - 3 gun tubes

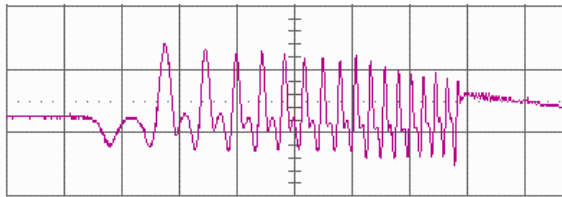

- Flight pressure sensor
  - low charge

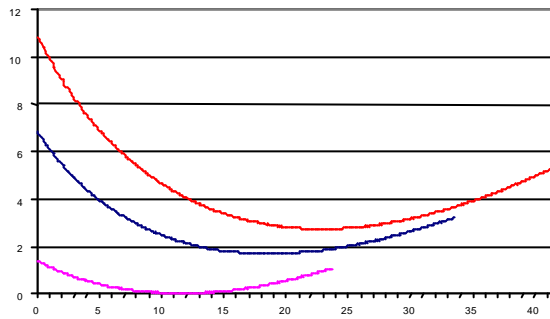

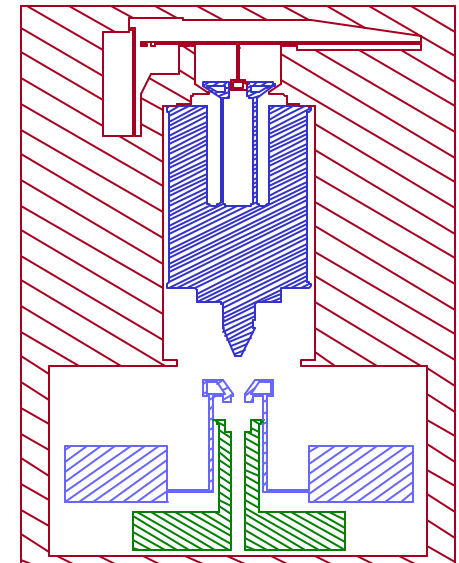

# FUTURE WORK

- Conduct safety review of system electronics
- Continue evaluation of 2nd environ sensors
- Design MEMS inertial switch
- Fabricate handset models
- Obtain user feedback
- Award EMD contract

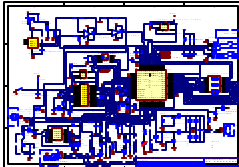
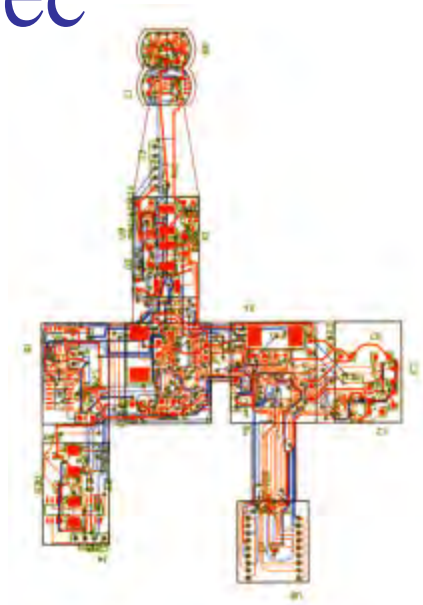

# CONCLUSION

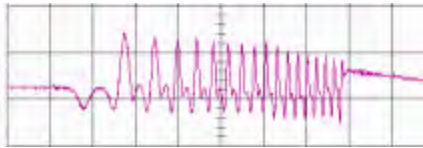
- In-house electrical design meets spec
- Fully functional breadboard
- Schematic 
- Prototype flex-circuit PWB 
- Software program for both micros
- M762 battery 
- LCD 
- 2nd environment prototypes 



**JAMI**  
**Flight Termination System**  
**A Cooperative Development**  
**Between**  
**NAWC/CL and KAMAN**

Dale Spencer, Presenter  
Andy Yuenger, Co-Author

**45<sup>th</sup> Annual Fuze Conference**  
**Long Beach, California**  
**April 18<sup>th</sup> , 2001**



# Overview



- **Joint Advanced Missile Instrumentation**
  - **Roles**
  - **System**
- **FTSA**
  - **Requirements**
  - **Features**
  - **Block Diagram**
  - **Design/Implementation**
  - **Test Results**
  - **Status**
  - **Plans**



## DEVELOPMENT UNDER CRADA



- Cooperative Research and Development Agreement
  - Raymond Engineering Operations (REO)
  - Signed 12 April 1999
  - Division of Responsibilities
    - **China Lake**
      - **Electrical/Explosive Design and Development**
      - **Environmental Testing**
    - **REO**
      - **Packaging**
      - **Hardware Manufacturing**



# JAMI FTS TEAM



- **Program Dir :** **Mr. Don Scofield, NAWCWD, China Lake**
- **Navy Deputy:** **Mr. Dave Powell, NAWCWD, Pt Mugu**
- **Project Engr:** **Mr. Andy Yuenger, NAWCWD, China Lake**
- **EE Design (Past):** **Mr. Mike Haddon, NAWCWD, China Lake**
- **EE Design (Present):** **Mr. Gabe Soto, NAWCWD, China Lake**
- **Analyst:** **Mr. Jim McVay, NAWCWD, China Lake**
- **Industry Partner: Kaman Aerospace Corporation/ Raymond Engineering**
  - **ME Design:** **Mr. Robert Spooner**
  - **FCDC Interface:** **Mr. Ted Horbacewicz**
  - **Test Engineer:** **Mr. Mario Fasulo**
  - **Reliability & Safety:** **Mr. Pete Rohner**
  - **Firmware:** **Mr. Pete Solari**
  - **Project Engineer:** **Mr. Dale Spencer**



# JAMI System



## WEAPON INSTRUMENTATION

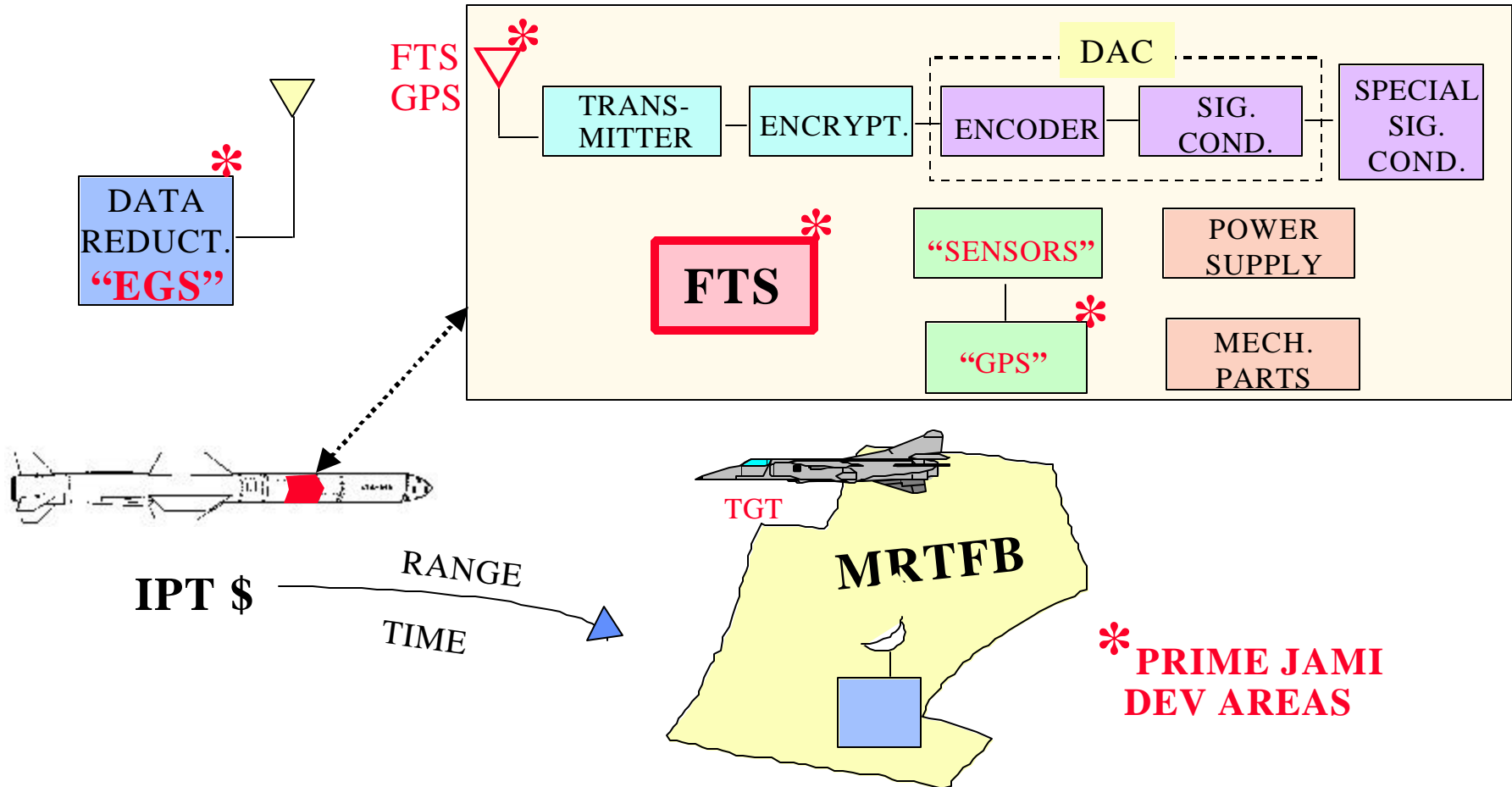

\* PRIME JAMI  
DEV AREAS



# FTSA in JAMI System

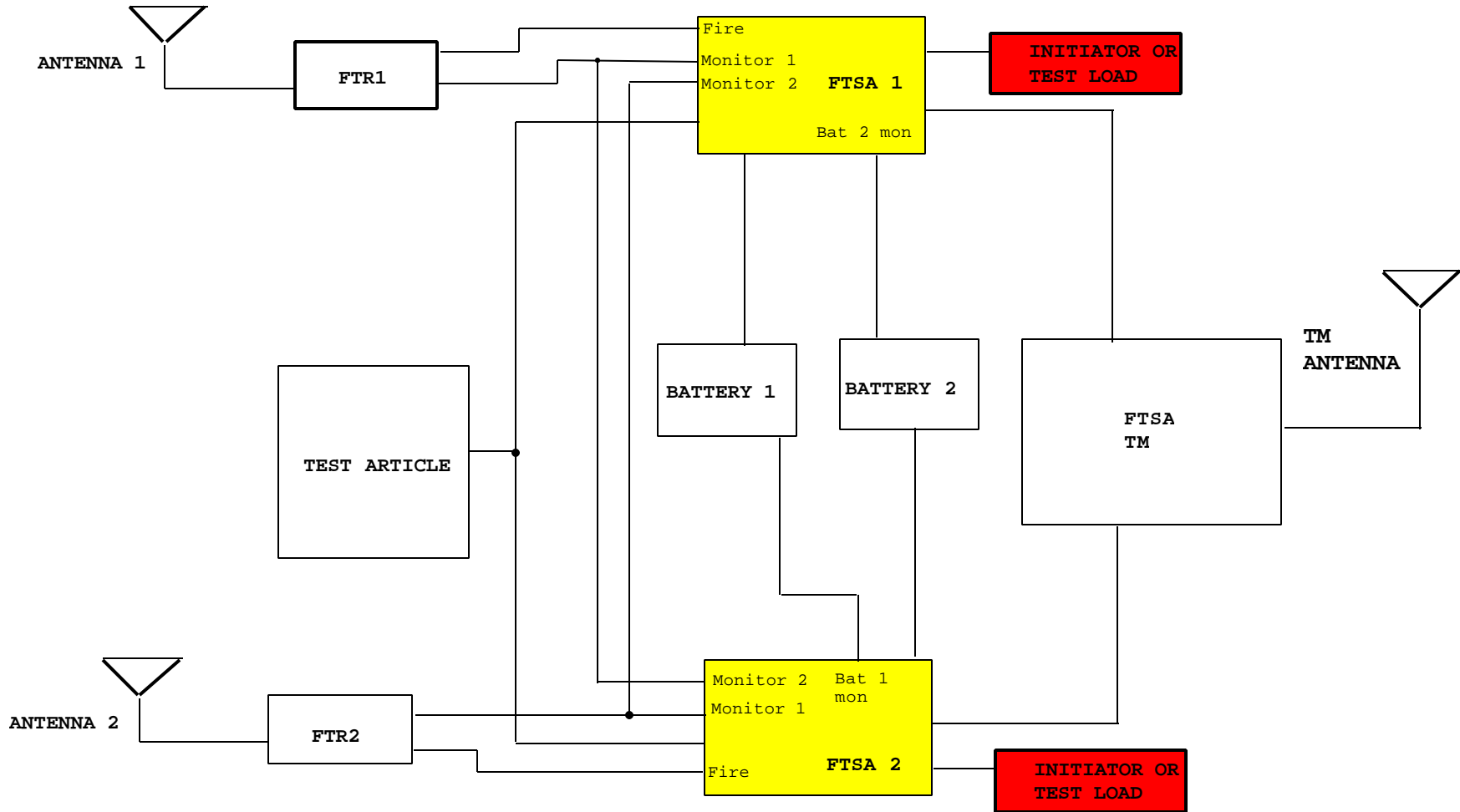



## FTSA VS S&A



- FTSA
  - Overriding Concern is to Not Allow the Weapon to Go Outside the Range Footprint
  - Defining Specification is RCC 319-99
- S&A
  - Overriding Concern is to Not Allow Unintended Initiations
  - Defining Specification is Mil-Std-1316



# JAMI FTSA BENEFITS



- Standardization
- Off-the-shelf availability
- Low Unit Cost
- Small Size & Weight



## JAMI FTSA Requirements



- Compliant With **RCC 319-99**
- **Programmable** For Multiple Applications (at test facility)
- **Small Size** (< 9 in<sup>3</sup>/unit)
- **Low Cost** (~\$2000/unit)
- Qualified To “**Worst Case**” **Environmental** Levels
  - Based on Environments of Potential Users
- **Removable Explosives** (LEEFI, Etc.)
- Fully **Testable** (Including HV Output)



# Block Diagram of JAMI FTSA

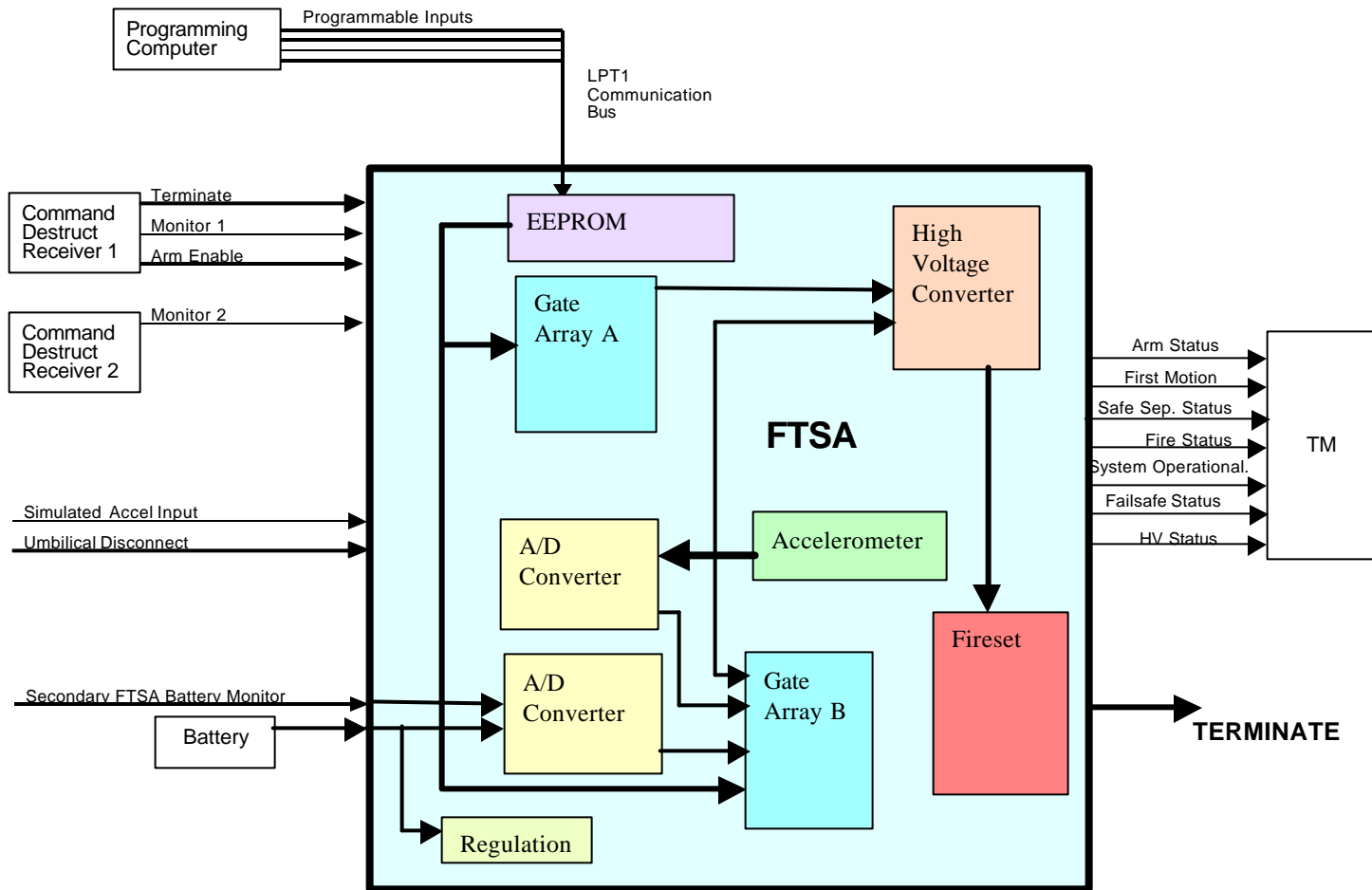



# INPUTS & OUTPUTS



- **Programmable Inputs**

- **Failsafe Enable**
  - Loss of Monitor (tone)
  - Loss of Power
- **First Motion Enable**
  - First Motion Valid Time
- **Acceleration Enable**
  - Axis of Acceleration
  - Acceleration Level
- **Umbilical Disconnect Enable**
- **Safe Separation Time**
- **Arm Enable**

- **Non-Programmable**

- **Terminate Command**

- **OUTPUTS**

- **Flight Destruct (Explosive)**
- **Safe/Arm Status**
- **Fire Status**
- **Safe Separation Status**
- **First Motion Status**
- **System Operational**
- **Failsafe Status**



# Logic Circuits

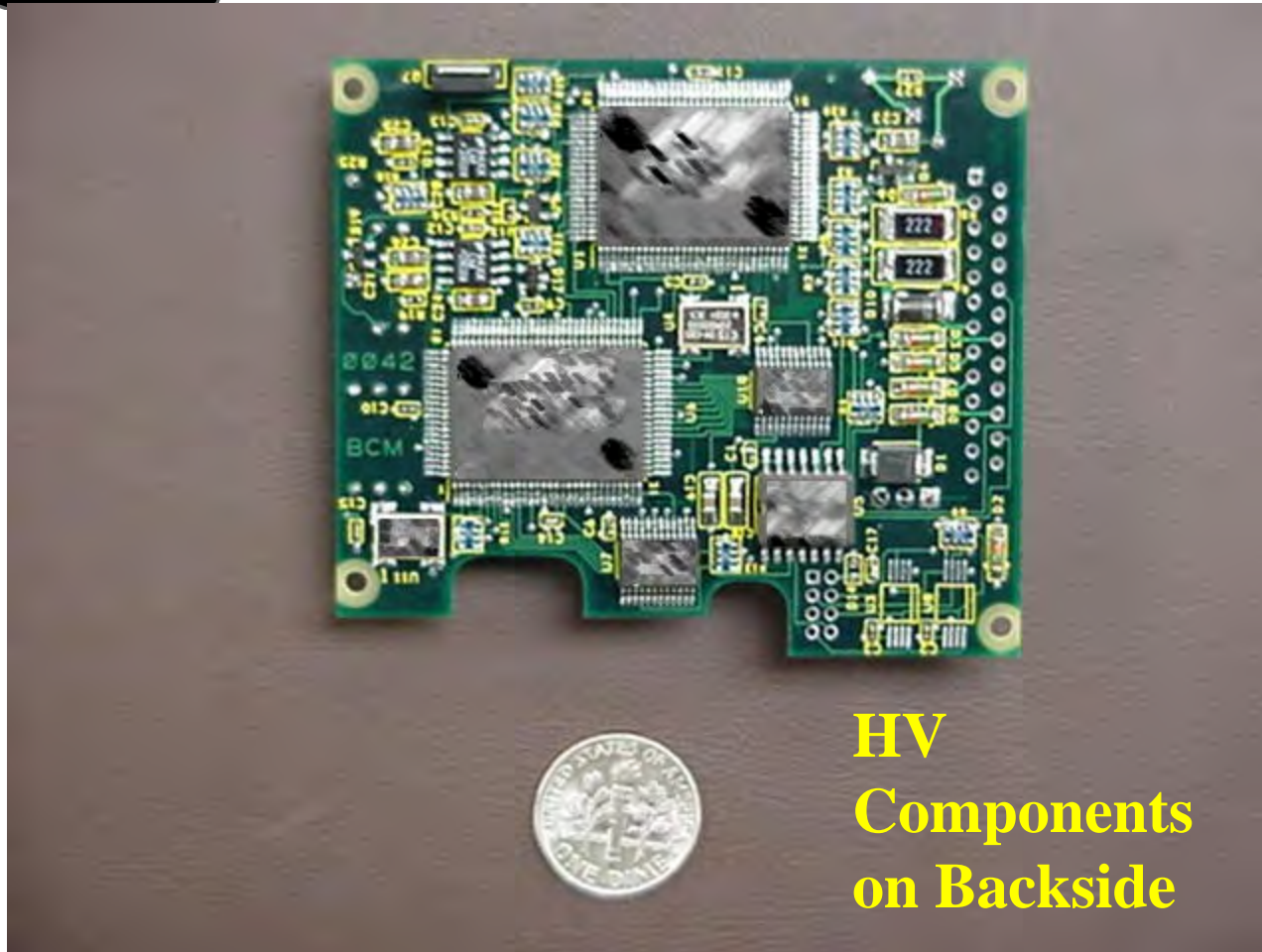

**HV  
Components  
on Backside**



# FTSA Housing Model

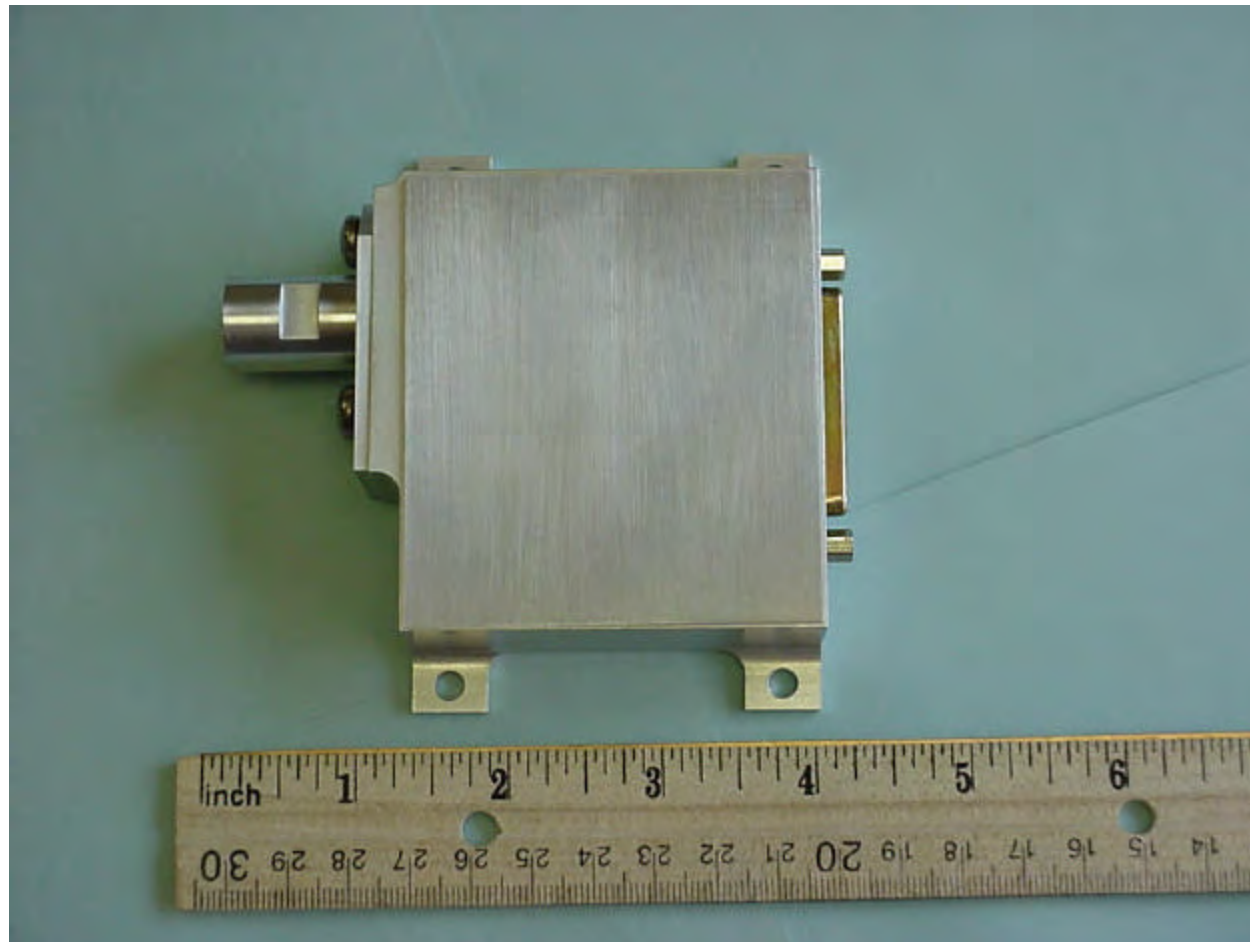



# FCDC Components

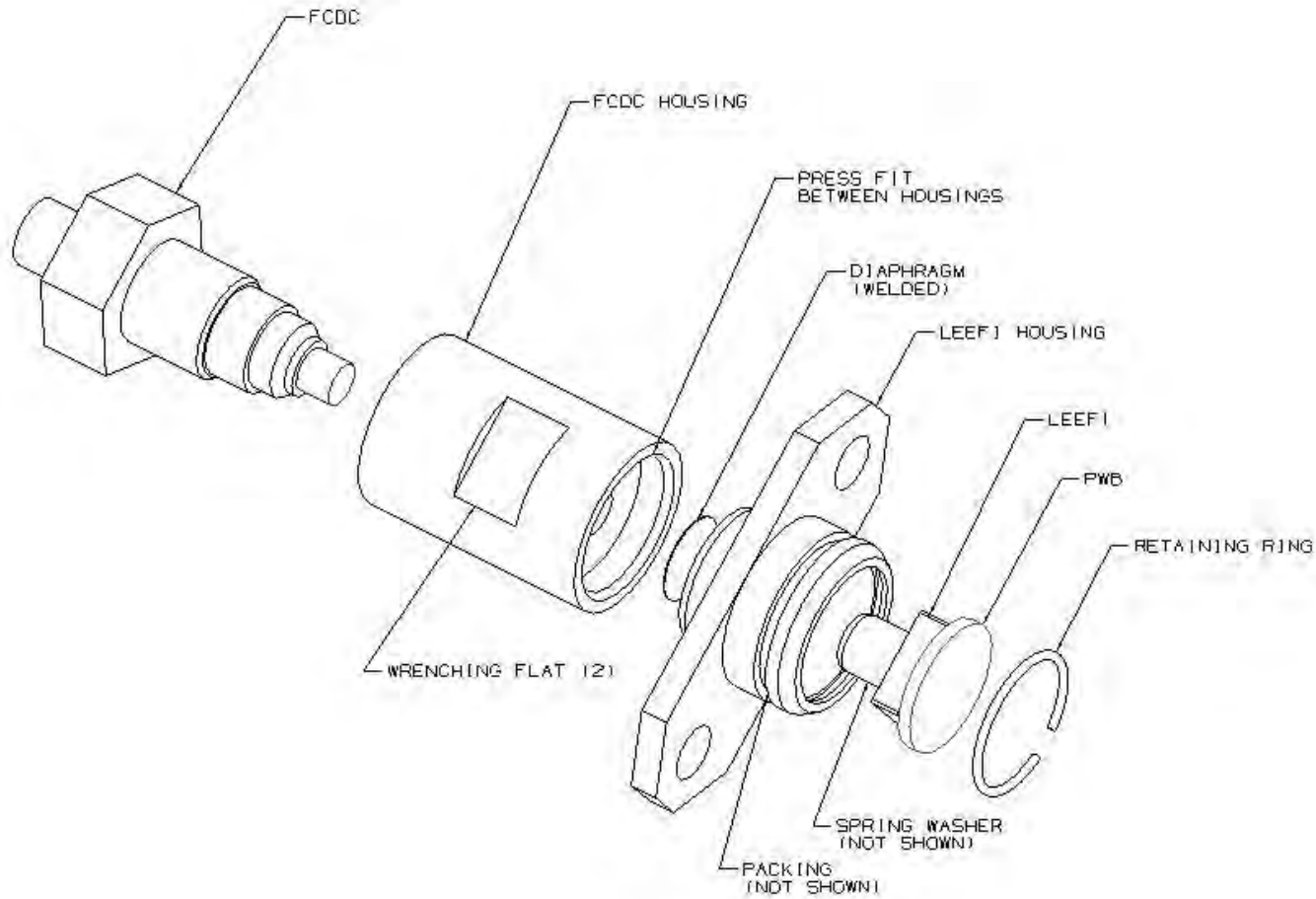



# JAMI FTSA FIRESET



- Novel Design
- Small In Size
- Low In Cost (<\$20)
- High Reliability
  - 3200 shots @ 1500A
- No Unique Parts
  - All COTS

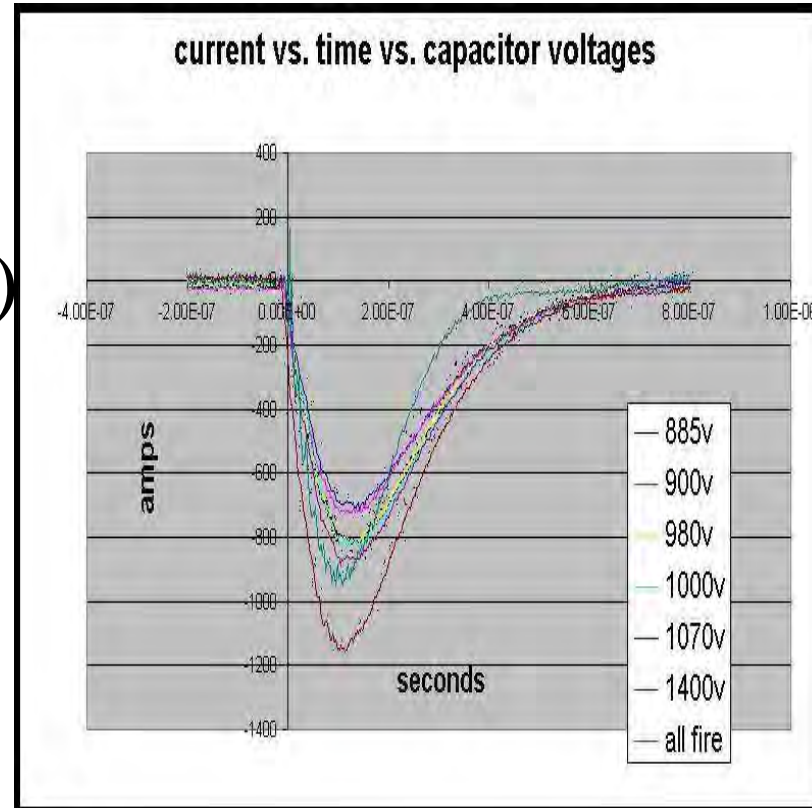



## TEST ENVIRONMENTS



- Range Safety Document RCC 319-99
  - May be First FTSA Fully Qualified to New Document
- Database of Environmental Profiles of Numerous Weapons Systems



## STATUS



- **Specification Completed**
- **Housing Design Complete**
- **FCDC Interface Complete**
- **Electrical Design Complete**
- **Prototype Board built and tested**
- **Fireset Studies Complete**
- **Pre-production**
  - **Design Update in final stage**
  - **Boards planned**
  - **Pre-Qualification tests to be run to find “weak points”**
  - **Expect Qualification Completion Second Qtr 2002**



# Developmental Testing Summary



- Fireset
- Logic Circuits
  - Functional Test of Disable Parameters
  - Programmable Time and Thresholds Verification
- Temperature Range Tests



# Developmental Test Errata



- **Electrical Corrections**
  - Q1 pins 3 & 4 Reversed
  - R19& R25 Resistance Value Change for Specified Threshold
    - 47.5k to 68k
  - Missing Run from R21 Node 6 to node 5
  - Missing Pad R17
  - Maxim A/D MAX154 no longer std. production item
  - 2SK2663 (HV Transistor) no longer in production.
- **Mechanical Corrections**
  - Component interference with Tactical Connector
  - Q7 on wrong side of board, through hole reverse placement
  - Component Height



# Design Analysis Summary



- **Tolerance**
  - Preliminary circuit tolerance analysis performed with pre-production design
- **Stress**
  - Design performed with TE000-AB-GTB-010 as a guideline
- **Fault Tree**
  - Design performed to preclude single point failure and implement desired modes of operation.
- **Final Analysis, including FMECA, to be completed in conjunction with pre-production evaluation testing.**



## Fire Circuit Tests



- **Established All-Fire Voltage**
  - Explosive Tests forthcoming
- **Temperature Cycled  $-30^{\circ}\text{C}$  to  $+92^{\circ}\text{C}$** 
  - Output Current degraded 5% maximum
- **Range Safety Requirement for 50% Energy Margin Exceeded** by 105 milli-joules threshold (predicted), 203 milli-joules available. Based on nominal capacitor value.



**KAMAN**



# Functional Verification Tests



## First Motion Valid

Programmed Time	Measured Time	% Error
5 Seconds	5.017	0.3
10 Seconds	10.017	0.2
155 Seconds	154.90	0.06
160 Seconds	160.03	0.02

## Safe Separation

Programmed Time	Measured Time	% Error
0.1 Seconds	0.10000	0
10 Seconds	10.2	0.19
25 Seconds	25.6	2.3



# Functional Verification Tests



## Loss of Power Threshold

Programmed Time	Measured Voltage	% Error
21 Volts	20.74	1.2
22 Volts	21.22	3.7
23 Volts	22.27	3.3
24 Volts	23.6	1.7
25 Volts	24.9	0.4
26 Volts	25.7	1.1
27 Volts	27.2	0.7
28 Volts	28.5	1.7

## Loss of Tone

Programmed Time	Measured Time	% Error
1 Second	1.02	2.0
2 Seconds	2.04	2.0
31 Seconds	31.7	2.2
32 Seconds	32.79	2.4



# Plans



- **Qualification Plan in Process**
- **Number of units under CRADA is 12**
  - **2 Pre-qualification Engineering**
  - **10 Range Qualification Units**

MILESTONE	00	01	02	03
• Prototype built & tested.....D	▲			
• Pre-production boards .....D built and tested				
• CDR.....D				
• Qualification Hardware built...D				
• Qualification.....D				



## FTSA Feedback



- Your Comments, Questions or Concerns



# Spin Rate Sensor for Fuzing Applications, Theory and Test Results

Presented by: Dale Spencer, Kaman

Co-Authors:

Tim Tiernan, TPL Inc.

Pete Solari, Kaman

Fred Piering, Dayron

Sponsor: W. Konick, ARDEC





# Overview

- Theory
  - Magnetic Field Sensor
  - Application
- Test
  - Methodology
  - Hardware
  - Set Up
  - Results
- Conclusions
- What's Next





# Roles

- Army Sponsor
  - **Ultra Sensitive Integrated Magnetic Field Sensors For Fuze Applications, Army Contract Number: DAAE30-99-C-1068**
- TPL, Inc **SBIR Phase II Contactor**-- Sensor
  - Kaman Subcontractor – Data Recorder and Packaging
  - Dayron -- 40 mm projectile, Range, Test





# Spin Rate Sensor Test Team



Dale Spencer , Tim Tiernan , William Konick, Carlos Tessonniere, Jim Nasternak , Kenny LaClair , Wes Sprouse , Pete Solari



4/18/2001

Page 4

D. Spencer/ T. Tiernan

**KAMAN**



# Theory -- Magnetic Sensor

- Giant Magnetoresistive material.
- The sensor can detect the ambient magnetic field of the earth with a high signal to noise ratio.
- The response of a GMR sensor is strongly related to its orientation with respect to a magnetic field.
- As the munition spins,
  - the sensor mounted inside changes direction with respect to the earth's magnetic field.
  - a sinusoidal waveform is output by the sensor as it moves from alignment to disalignment with the earth's magnetic field with each revolution of the munition.



# Theory Applied

- Application Theory  
Developed by TPL, Inc
  - Resolve shell dynamic rotations
  - Rotations for fixed rifling equal distance
  - Multiply rotations to obtain distance

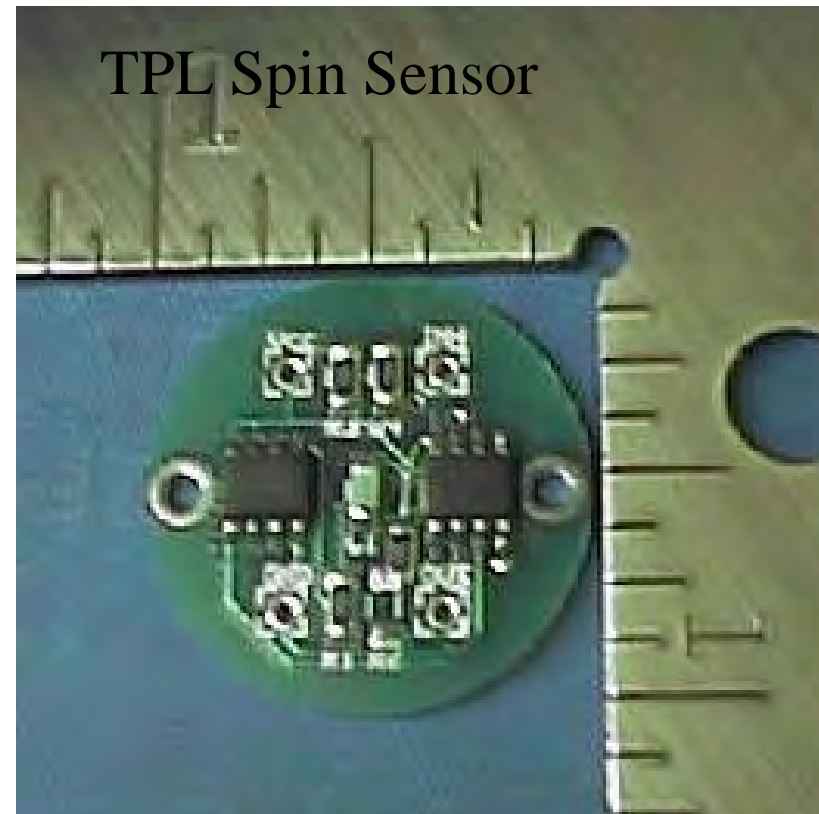

4/18/2001

Page 6

D. Spencer/ T. Tiernan

**KAMAN**

# Test Methodology

- Dynamic Firing Test
  - Validate Theory through live fire demonstration
  - Build Sensor
  - Integrate Sensor and Data Recorder into projectile.
  - Fire Projectile in Gun with known rifling
  - Measure projectile velocity
  - Compare Projectile turns per second with velocity

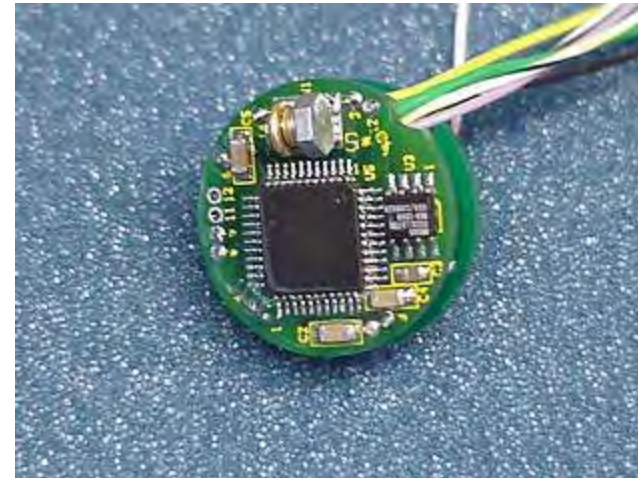

KAMAN Data Recorder

Integrated with TPL  
Spin Sensor



4/18/2001

Page 7

D. Spencer/ T. Tiernan

**KAMAN**



# Conceptual Package for Test

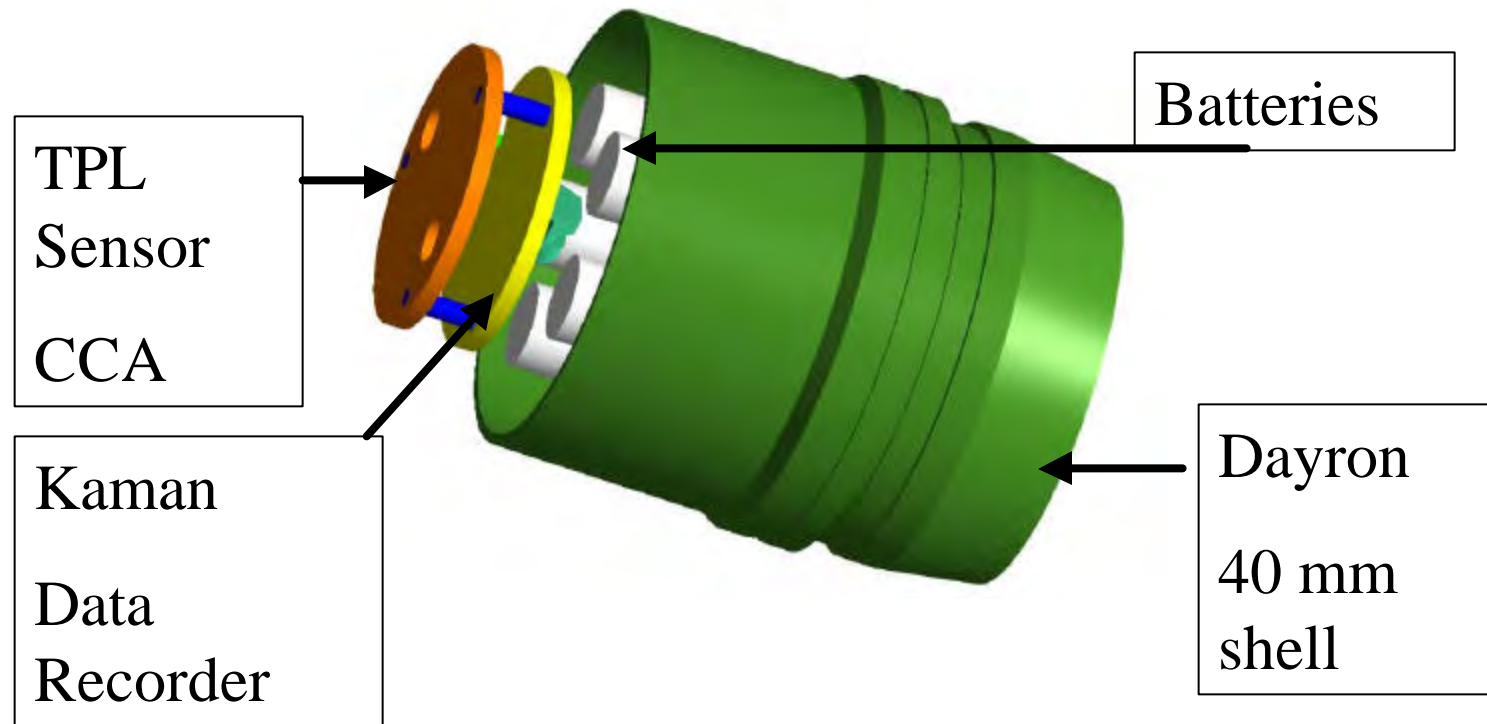

3-D Packaging by R. Spooner, Kaman





# Test Projectiles



Note: Rifling Grooves, this projectile has been fired and recovered



# Data Interface

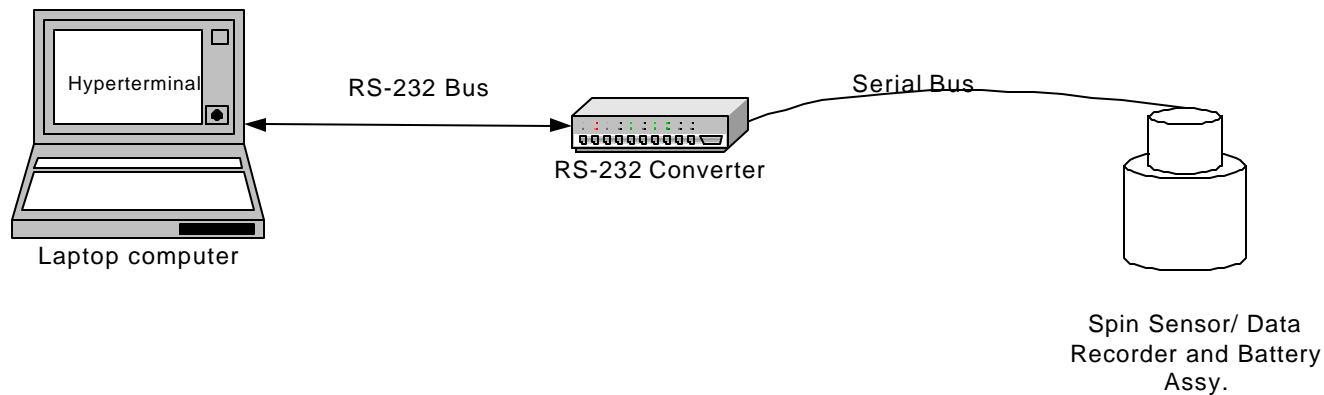

- PC Running Hyperterminal
- Arming Parameters Set Via RS-232 Port
- Data Downloadable To PC's Via RS-232 Port
- All Code Embedded in Recorder
- No peculiar PC software



4/18/2001

Page 10

D. Spencer/ T. Tiernan

**KAMAN**



# Bench Test

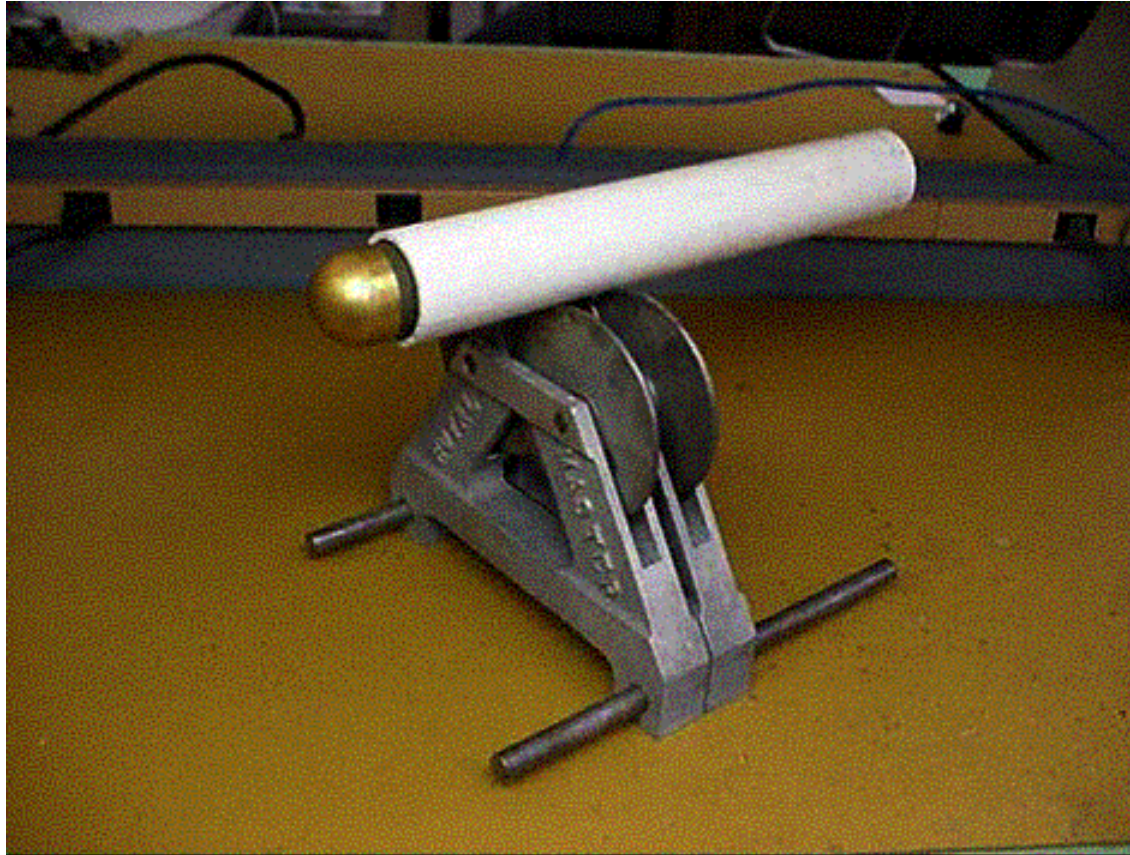



# Bench Test

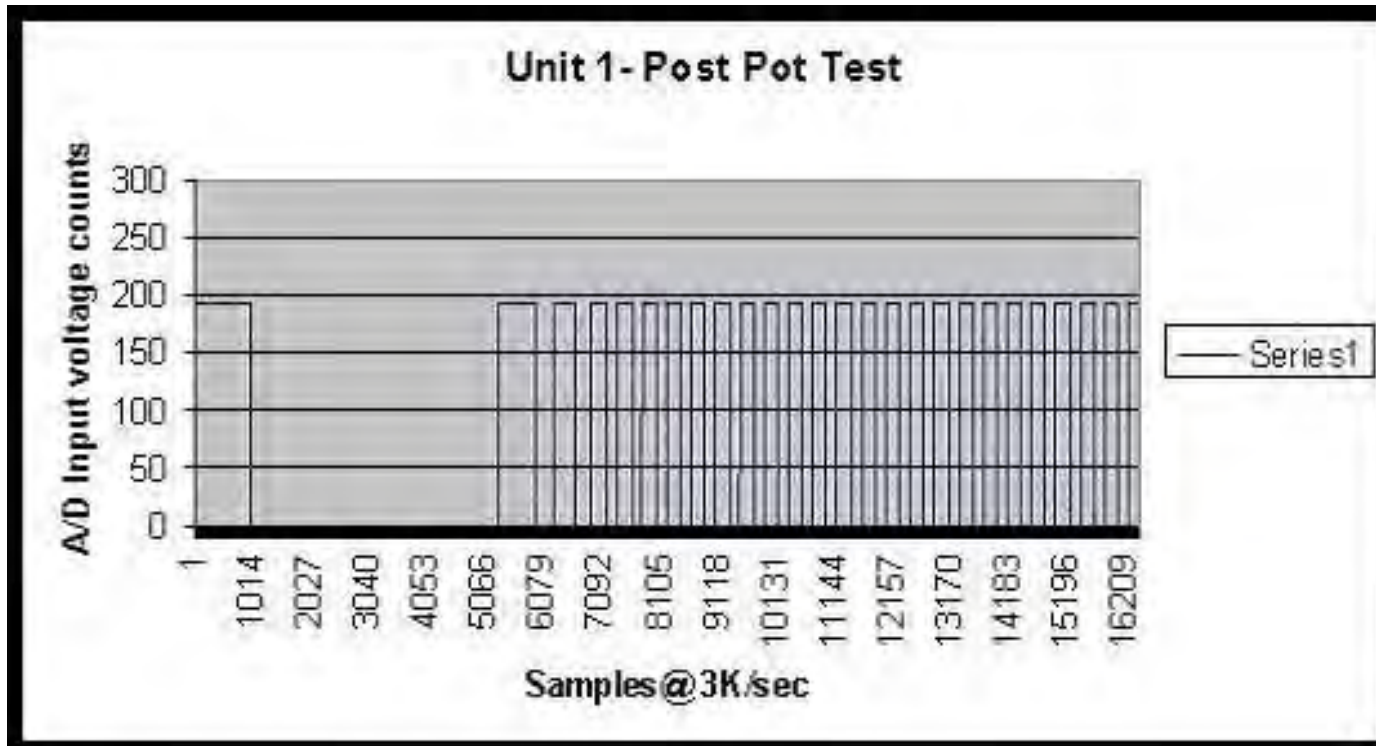

Spin up rate as expected

Transition from low to high as expected





# Test Range



# Shot # 1 Results

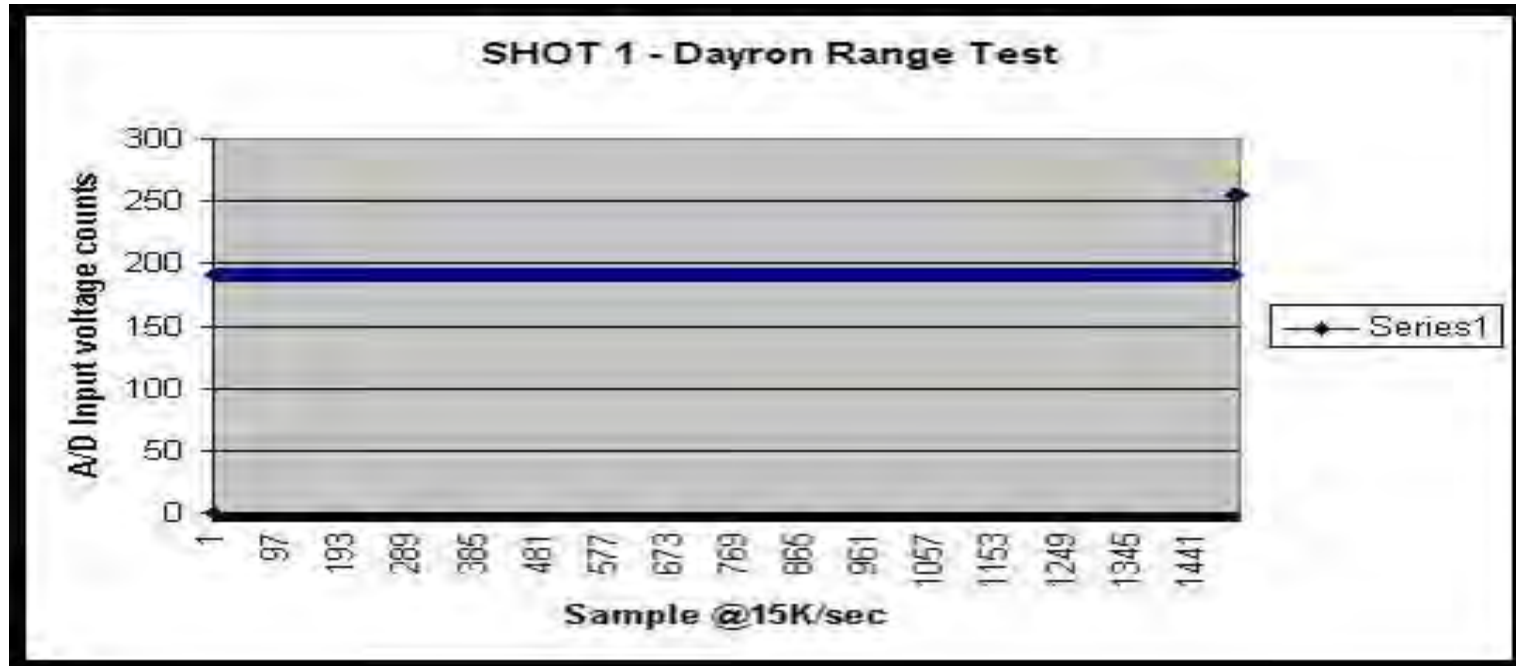

- Flat Line Indicated Problem in First Test
  - First Bit Low and Last High Indicated Recorder OK
  - Digital Value Corresponded to Saturation



# Shot # 2 Results

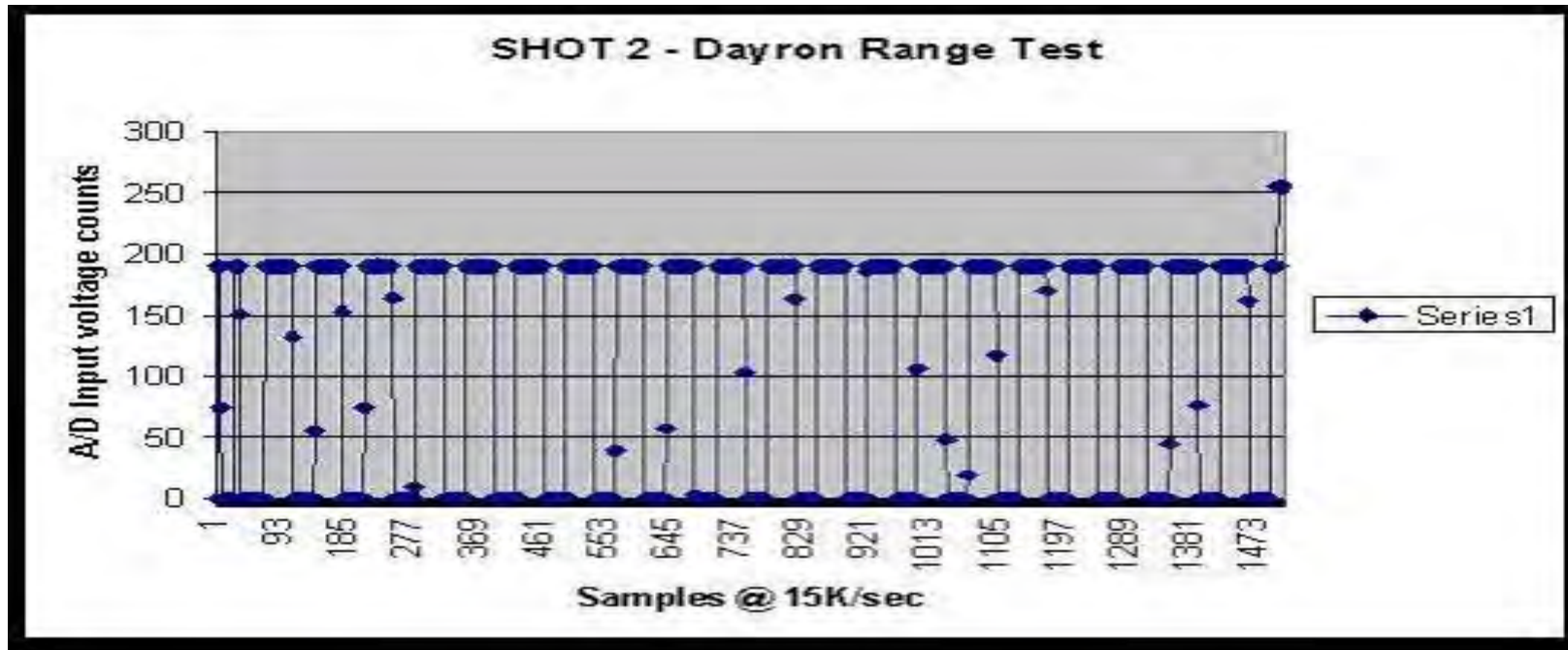

- Interesting Data
  - Calculated velocity higher than expected
  - Decide to measure velocity with laser diode velocimeter for next shot



# Test Shot #3

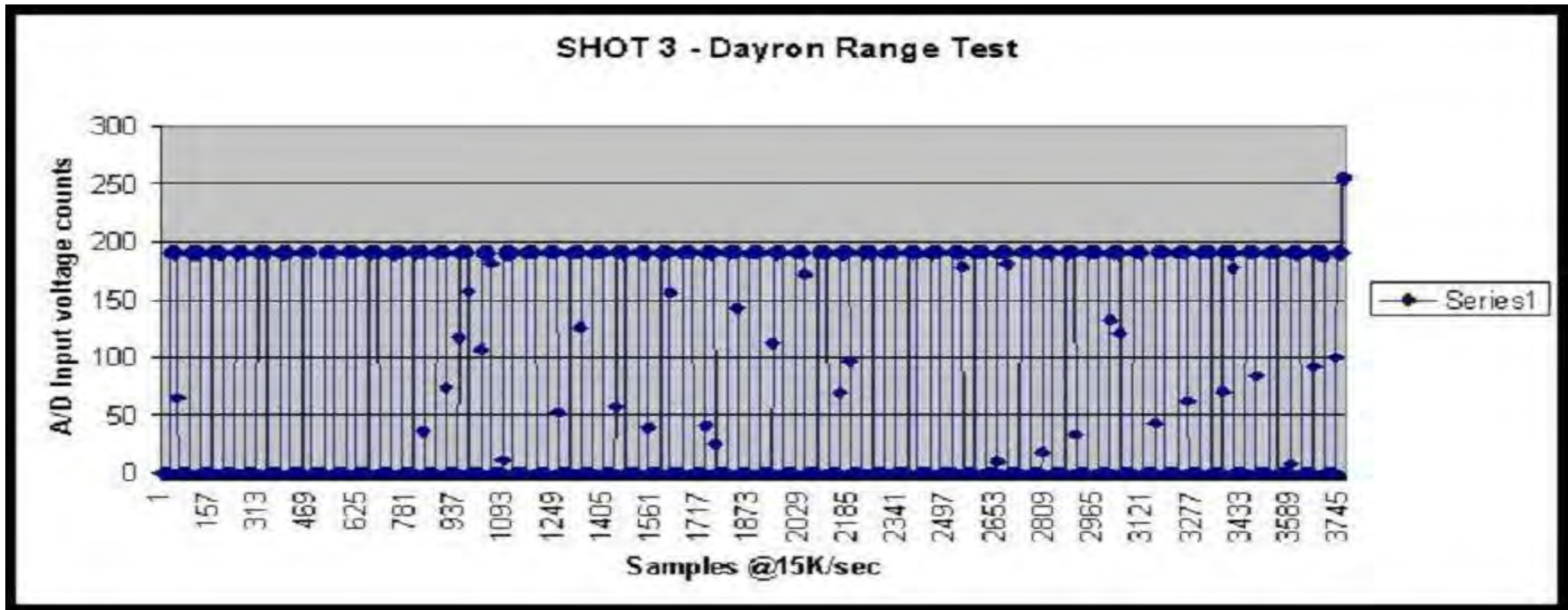

- Good Data
- Measured Velocity = Spin Rate Velocity < 1% error



4/18/2001

Page 16

D. Spencer/ T. Tiernan

**KAMAN**



# Test Results

Shot #3	Measured Muzzle Exit Velocity (ft/sec)	Weight (lb)	Number of Turns	Predicted Flight Distance @ 0.25sec Flight Time (ft)	Turns Calculated Flight Distance (ft)	Error (%)
Dayron Round	813	0.740		203.25		
SR Round	831	0.722	51.5	207.75	206.00	0.84

**Predicted Flight Distance == Muzzle Velocity \* Flight Time = 831 \* 0.25 = 207.75 ft**

**Turns Calculated Flight Distance = # of Turns \* 4 ft/Turn = 51.5\* 4 = 206.0 ft**

**% Error = ((Predicted Flight Distance - Turns Calculated Flight Distance) / Predicted Flight Distance) \* 100 = ((207.75 - 206)/207.75) \* 100% = 0.84%**





# Conclusions

- Test was a success
- Sensor capable of resolving spin rate accurately
- Sensor is survivable and working immediately upon exit from barrel
- Recorder is survivable and working prior to exit from gun barrel





## ***Design Methodology for Safe and Arm Devices***

---



# ***Design Methodology for Safe & Arm Devices***

Dipl.-Phys. Friedrich Sauerländer



# Design Methodology for Safe and Arm Devices



## Who am I?



**NAWC WPNS**  
Ordnance Systems  
Division  
China Lake, CA



**BWB**  
WF I 5  
Koblenz, Germany





## **Outline**

- **S&A Development Process**
  - Steps to a safe S&A
  
- **Fault Tree Analysis**
  - How to do it right

*Full Report available from: [FowlerSE@navair.navy.mil](mailto:FowlerSE@navair.navy.mil)*



# Design Methodology for Safe and Arm Devices



## Where to start?



## Structure of S&A Design

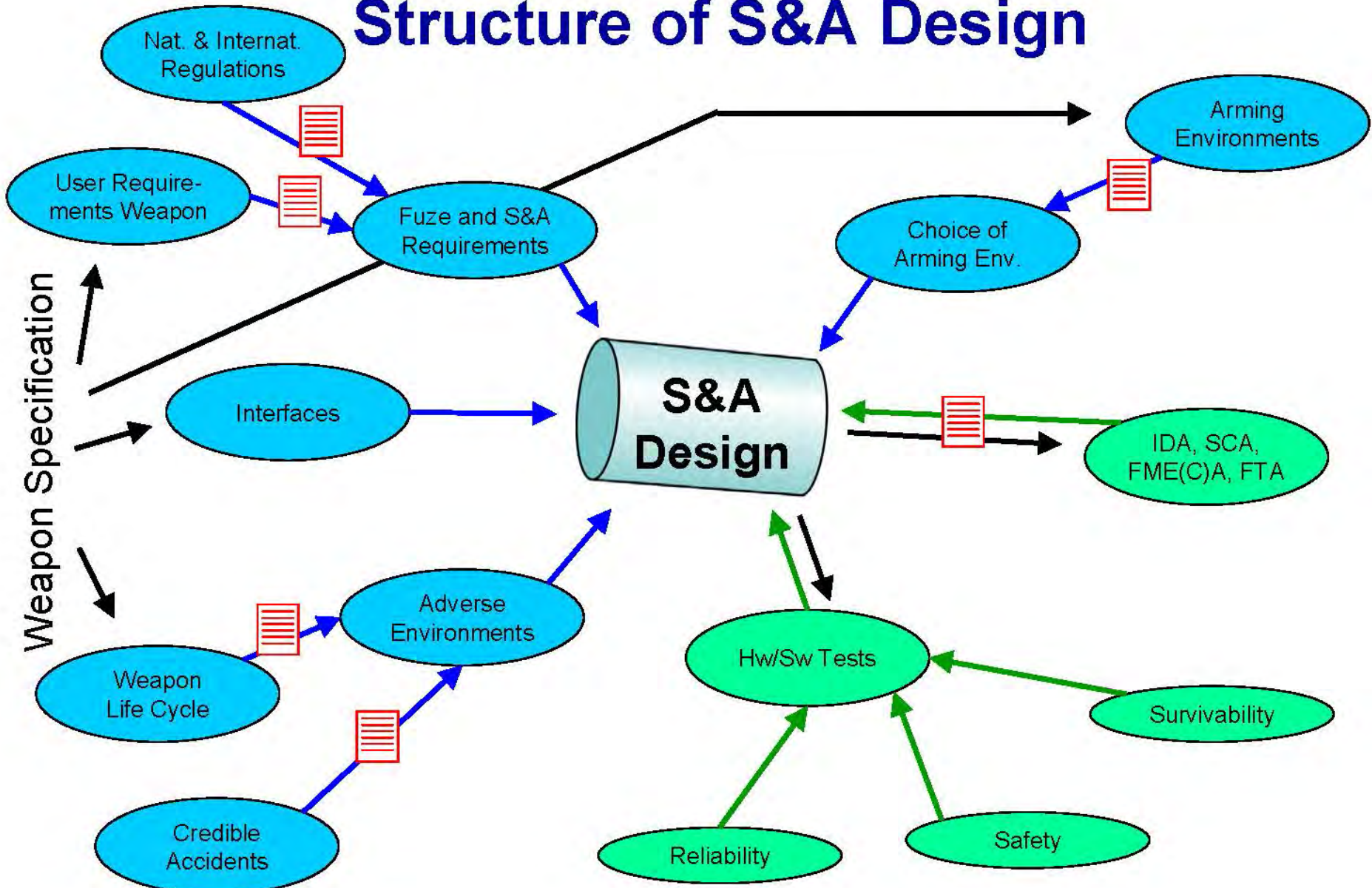



## S&A Design Process

### Given Parameters

- basic requirements
- interfaces
- adverse environm.
- chosen arming environments
- ...

### Design Variables

- arming environments
- arming logic/sequence
- basic S&A type
- explosive train
- fail safe features
- materials/parts
- internal signal processing
- ...

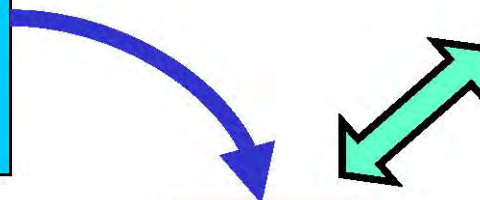

PHA

S&A Design

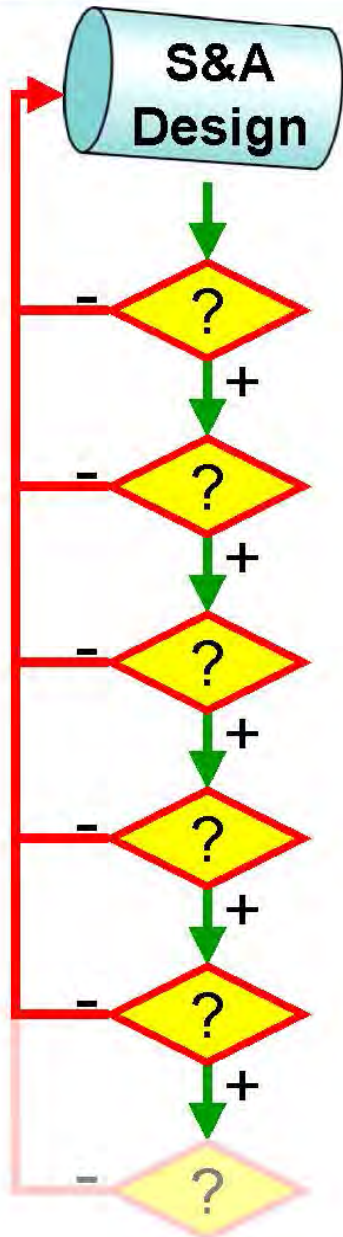

## S&A Design Process

- 1) Design can be simplified
- 2) Design is fail safe
- 3) Preliminary FTA
- 4) Hazard Analysis
- 5) Sneak Circuit Analysis
- 6) ...

## S&A Design Process

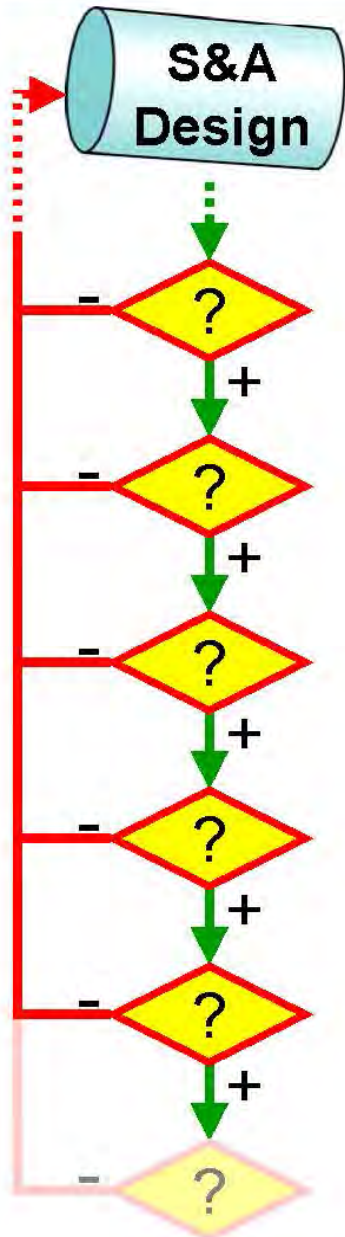

6) Producability

7) Integrated Design Analysis (OL tree, ...)

8) FME(C)A

9) FTA

10) Reliability

11) ...

## S&A Design Process

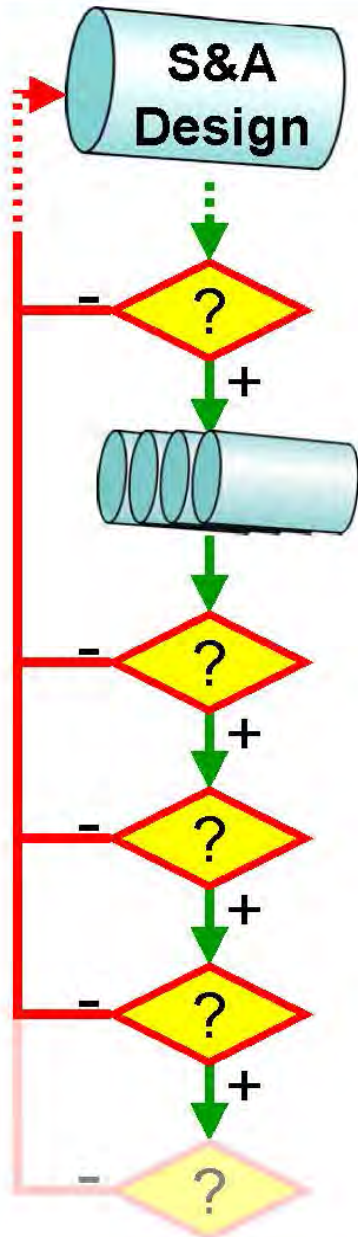

11) Component Tests

*Production of Test Samples*

12) Function Tests

13) Qualification Level Tests

14) Test to Failure

15) ...

## S&A Design Process

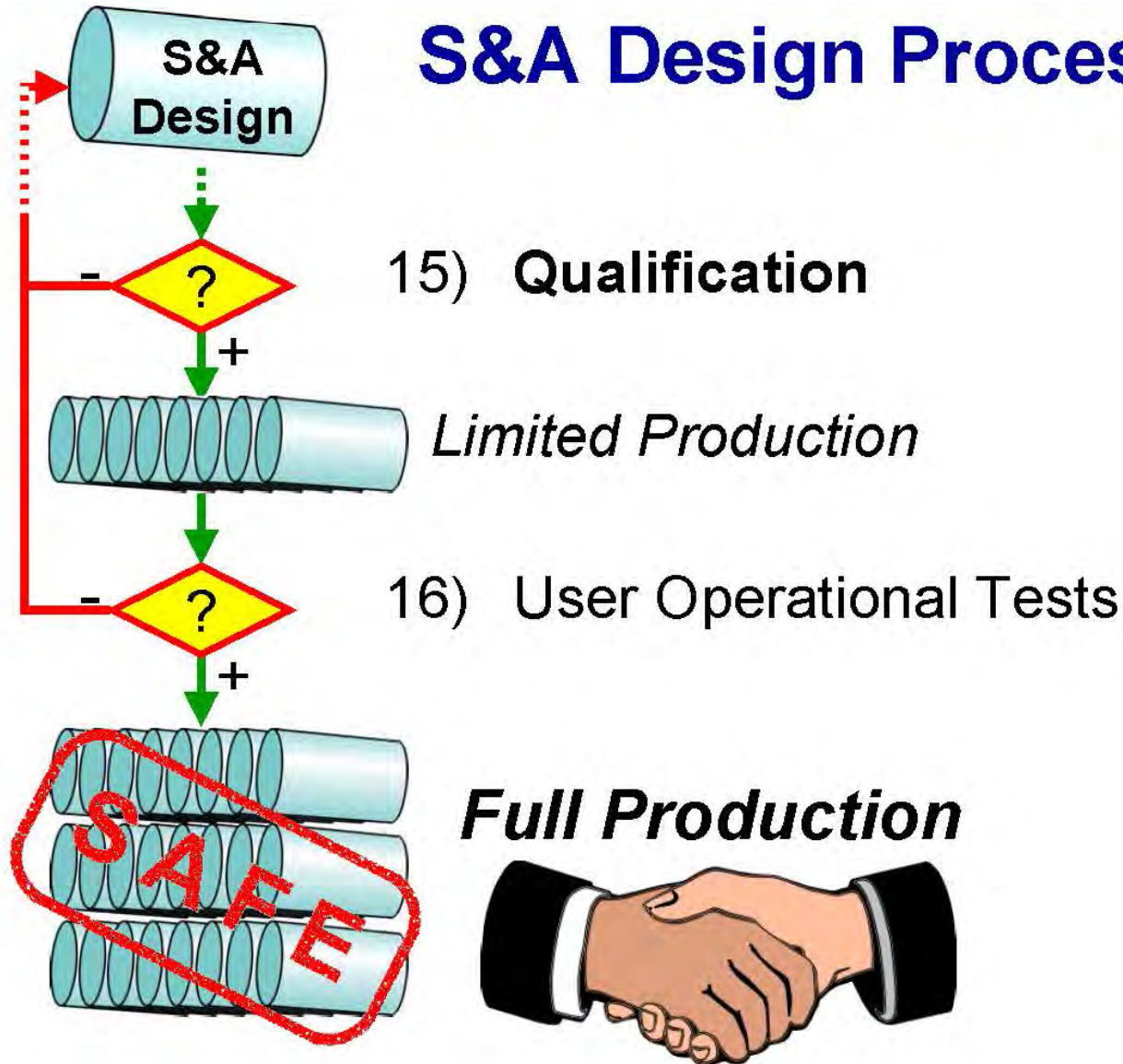



## **Outline**

- **S&A Development Process**
  - Steps to a safe S&A
- **Fault Tree Analysis**
  - How to do it right





## Fault Tree Analysis

- FTA is basis for quantification of risk (target:  $1:10^6$ )

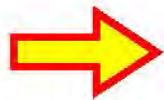

**FTA is critical for safety evaluation**

Fault Tree  
Structure

Probabilities of  
Primary Events



# FTA - Tree Structure

- top events are Premature Arming and Early Burst
- the Fault Tree must be build on and verified at least against:
  - (P)HA
  - FME(C)A
  - drawings & schematics
  - Operation Logic Tree (from IDA)
  - SCA
- a FTA must include Primary, Secondary and Command Faults (e.g. credible accidents, errors during manufacture)



# **FTA - Tree Structure**

- the Fault Tree should be developed into a level, where every fault from the FME(C)A and other analyses is mentioned
- subsequent deletion of limbs must be mentioned and explained



# FTA - Quantitative Analysis

- provide the origin of all used data, scaling factors and expressions and explain, why they are applicable
- provide all raw data necessary to duplicate the analysis (e.g. type component, failure rate, quality level, environmental factors)
- **for ESAD** the following standard sources of failure rates should be used (as of 04/2001)
  - EPRD-97
  - NPRD-95
  - NONOP-1
  - MIL-HDBK 217(F)



## FTA - Quantitative Analysis

- pooling of data:
  - if - for a part only a limit of failure rate is given (“> ...”)
  - and - for similar parts the failure rates are well defined,the following expression may be used for pooling (EPRD-97):

$$\lambda_{pool} = \left( \prod_{i=1}^{n'} \lambda'_i \right)^{\frac{1}{n'}} \cdot \left( \frac{\sum_{i=1}^{n'} h'_i}{\sum_{i=1}^n h_i} \right)$$

$\lambda_{pool}$ : resultant failure rate  
 $\lambda'_i$ : failure rate of part  $i$  with failure  
 $h_i$ : time of part  $i$   
 $h'_i$ : time of part  $i$  with failure  
 $n$ : pooled parts  
 $n'$ : pooled parts with failure



# FTA - Quantitative Analysis

- apply a safety factor of 5 to all probabilities (to compensate for statistical uncertainties and deviations of actual parts)
- probability of failure is accumulated over all phases of weapon life cycle
  - storage (ground, field, mobile,...);  $\Sigma = 20$  years
  - logistic transportation
  - mounted on weapon or A/C carriage
  - launch & flight/fall

$$P(\lambda, t) = \sum_i \lambda_i \cdot t_i$$

$P$  : probability of failure  
 $\lambda_i$  : failure rate in environment  $i$   
 $\lambda_i = MTBF_i^{-1}$   
 $t_i$  : duration of environment  $i$



## FTA - Quantitative Analysis

### Example 1:

Electronic part, highly reliable but sensitive to environment

Environment	Time	$\lambda$ [ $10^{-6}/h$ ]	$P(\lambda,t)$	%
Ground Storage (GB)	20 yrs. = 170,265 h	0.001	$1.7 * 10^{-4}$	53
Field Storage (GF)	6 months = 4,383 h	0.01	$4.4 * 10^{-5}$	14
Transportation (GM)	21 days = 504 h	0.05	$2.5 * 10^{-5}$	8
A/C carriage (AUF)	7 days = 168 h	0.5	$8.4 * 10^{-5}$	26
Launch & Flight (ML)	120 s = 1/30 h	5	$1.7 * 10^{-7}$	0.05
			<b><math>3.2 * 10^{-4}</math></b>	



## FTA - Quantitative Analysis

### Example 2:

Electronic part, less reliable, less sensitive to environment

Environment	Time	$\lambda$ [ $10^{-6}/h$ ]	$P(\lambda, t)$	%
Ground Storage (GB)	20 yrs. = 170,265 h	0.05	$8.5 * 10^{-3}$	92
Field Storage (GF)	6 months = 4,383 h	0.1	$4.4 * 10^{-4}$	5
Transportation (GM)	21 days = 504 h	0.2	$1.0 * 10^{-4}$	1.1
A/C carriage (AUF)	7 days = 168 h	0.8	$1.3 * 10^{-4}$	1.5
Launch & Flight (ML)	120 s = 1/30 h	2	$6.7 * 10^{-8}$	0.001
			<b><math>9.2 * 10^{-3}</math></b>	



## **Conclusion**

### **I have tried to show**

- “Best Practice” Way of S&A Development
  - General Step-By-Step List
- “Best Practice” for FTA
  - highlighted points for FTA structure
  - guidelines for quantitative analysis

based on experiences in Germany, USA and with NATO AC/310, SG II.

*Full Report available from: [FowlerSE@navair.navy.mil](mailto:FowlerSE@navair.navy.mil)*



# **NDIA**

## **45<sup>th</sup> Annual Fuze Conference**

### ***Design and Development of a new Electronic Time (ET) Fuze for Mortars (XM784/XM785)***

**18 April 2001**

**TACOM-ARDEC Fuze Division  
Anthony Pergolizzi and Dennis Ward**

**T**ank-automotive & **A**rmaments **COM**mand



# XM784 / XM785 Electronic Time Fuze for Mortars



- Background
- Need
- Requirements Overview
- Programmatic Approach
- Schedule
- Technical Approach





# **XM784 / XM785 ET Fuze for Mortars**

## ***Background***

---



- **No US Fielded ET Fuze for Mortars Exists**
  - **US Requirements Filled By Foreign Source**
  - **M776 / M772 Diehl/Junghans (Germany)**
    - **Under Waiver From US Safety Standards**
- **User Persistently Indicated Need For a US ET Fuze (Since Mid '80's)**
- **No NDI Design Solution Exists**
  - **Foreign Comparative Studies**
  - **Engineering Studies**
  - **Contractor Studies**



# XM784 / XM785 ET Fuze for Mortars *Need*



- **Army Safety Standards**
  - **No Current Time Fuze Meets Standards**
- **Need For Increased Timing Accuracy**
  - **Poor Fuze Accuracy**
  - **Adversely Effects Cartridge Performance**
- **Three Fuze Types**
  - **PROX: (M734A1 Multi-Option Fuze)**
  - **PD / Delay: (XM783)**
  - **Time: (XM784 (60 / 120 mm) & XM785 (81 mm))**
- **Legacy Fuzes Require a Wrench To Set**
  - **Difficult to Read**
  - **Require External Lighting**
- **Mortar Time Fuze Modernization**



# **XM784 / XM785 ET Fuze for Mortars**

## *Requirements*

---



- **Safety Per MIL-STD-1316 (Dual Environ Safety)**
- **Cartridge Compatibility:**
  - 60 mm (M721 Illum & M767 IR Illum)
  - 81 mm (M853A1 Illum, XM816 IR Illum & M819 RP Smoke)
  - 120 mm (XM930 Illum, XM983 IR Illum)
- **Hand Settable Required (Inductive Set Desired)**
  - Self Illuminating
- **Accuracy 98%**
- **Set Time 5 – 99.9 Seconds (0.1 Sec Increments)**
- **Cannot Significantly Degrade Cartridge Range**
- **20 Year Shelf Life (Controlled Environment)**



# **XM784 / XM785 ET Fuze for Mortars**

## ***Programmatic Approach***

---



- **Systems Engineering / IPT Approach**
- **Initial Gov't Eng Activity – Risk Mitigation Effort**
- **Solicit Contractor – Competitive / Cost Plus Type**
  - **Phase 1: Develop & Demo Design Solutions (Award Fee)**
  - **Phase 2: Production Qualification / TC (Award Fee)**
    - **Conduct Government Ballistic Tests**
    - **TC Standard**
  - **Phase 3: Low Rate Initial Production (Incentive Fee)**
    - **LRIP Effort (22k – 60k fuzes)**
      - **FAAT**
      - **Three Production Lots to MR**



# XM784/ XM785 ET Fuze for Mortars

## Schedule

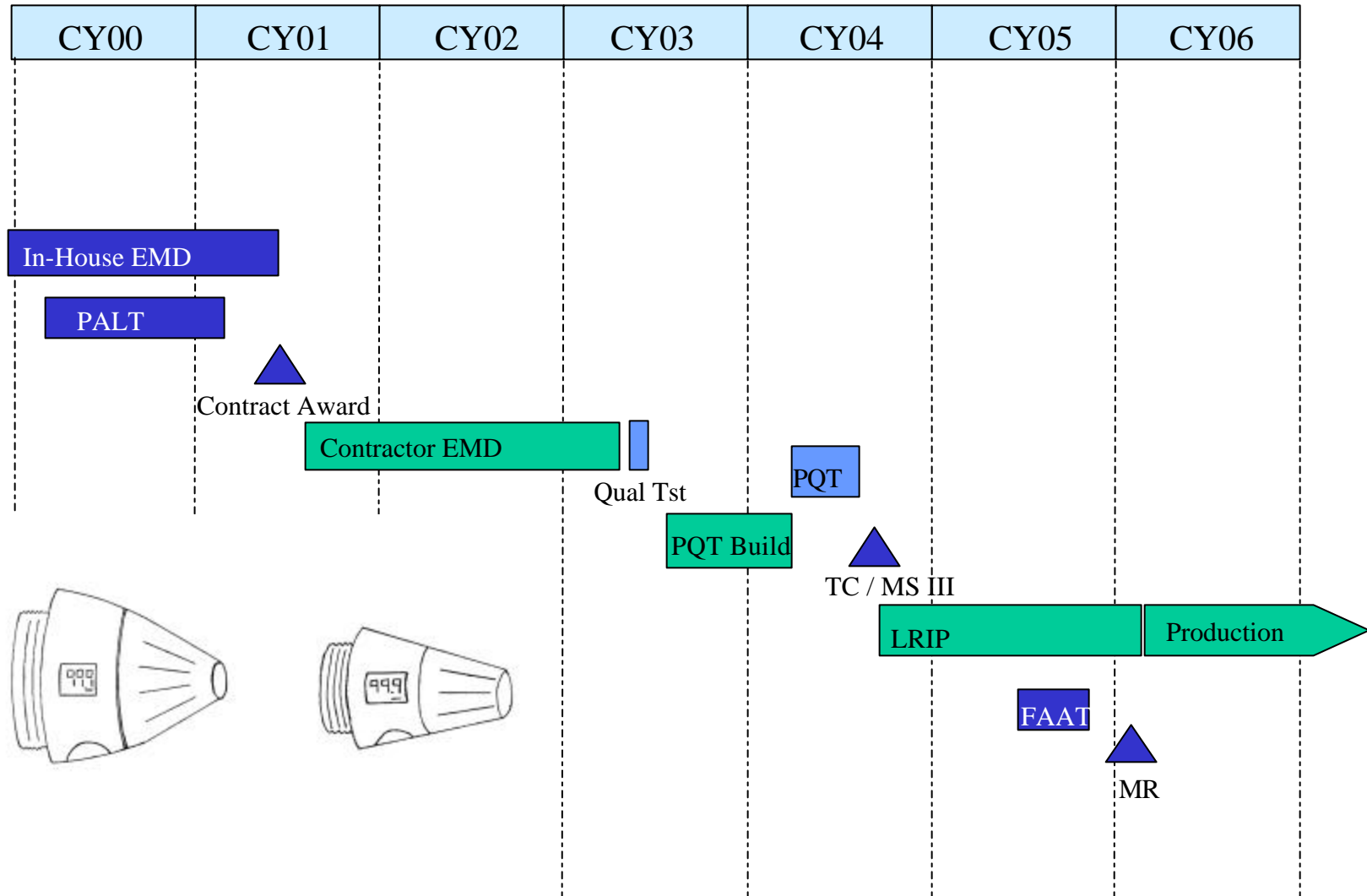



# **XM784/ XM785 ET Fuze for Mortars**

## *Technical Approach*



- **Maximize Use of NDI Components**
  - **Minor Modifications**
- **Initial In-House EMD**
  - **Develop Expertise For Source Selection**
  - **Development / Technology Exploration**
    - **Fuze Electronics**
    - **Power Source**
      - **Pre & Post Launch Battery Solutions**
      - **Non-Battery Solutions**
    - **Safety & Arming Device (incl 2nd Env Sensor)**
      - **Pressure Sensor**
      - **Muzzle Exit Sensor**
      - **Air Flow Sensor**
    - **Explosive Train**
    - **Packaging and Hand Setting**



# **XM784/ XM785 ET Fuze for Mortars**

## *Electronics*

---



- **Developed a power budget**
- **Evaluated the tradeoffs of an ASIC vs a microcontroller**
- **Designed and fabricated generic surface mount breadboard**
- **Uses a lithium reserve battery (M762 style)**
- **Developed schematic diagrams, safety logic, flow charts, and block diagrams have been developed**
- **Uses an inertial “T<sub>0</sub>” switch and impact sensor**
- **Developed logic software for the main and safety microcontrollers**
- **Interfaced the logic software with the breadboard and conducted bench tests**



# XM784/ XM785 ET Fuze for Mortars

## *Power Supply*



- **Studied candidate solutions:**

### Electro-chemical

M80  
SD Fuze  
OICW  
M762  
Active lithium  
thermal

### Non-chemical

Piezo-electric  
Electro-magnetic  
Setback generator  
Fluidic generator  
Turbine alternator

- **Capacitor cost / performance trade-offs may prohibit non-chemical initiatives**
- **Evaluated both an Evans Capattery and M762 battery for operation with our circuit**



# **XM784/ XM785 ET Fuze for Mortars**

## *Second Environment Sensor*

---



- **Researched several approaches:**
  - Pressure / Force
  - Muzzle Exit (Mag, ESS, RF)
  - Air Flow (Turbine driven lock)
- **Conducted RF sensor free fall drop tests**
  - 60mm, 81mm and 120mm tubes
- **Generated pressure profile plots**
- **Adapted a COTS pressure sensor**
  - Evaluated via laboratory flow-controller tests
- **Conducted aeroballistic tests in wind tunnel**



# XM784/ XM785 ET Fuze for Mortars

## *Second Environment Sensor*

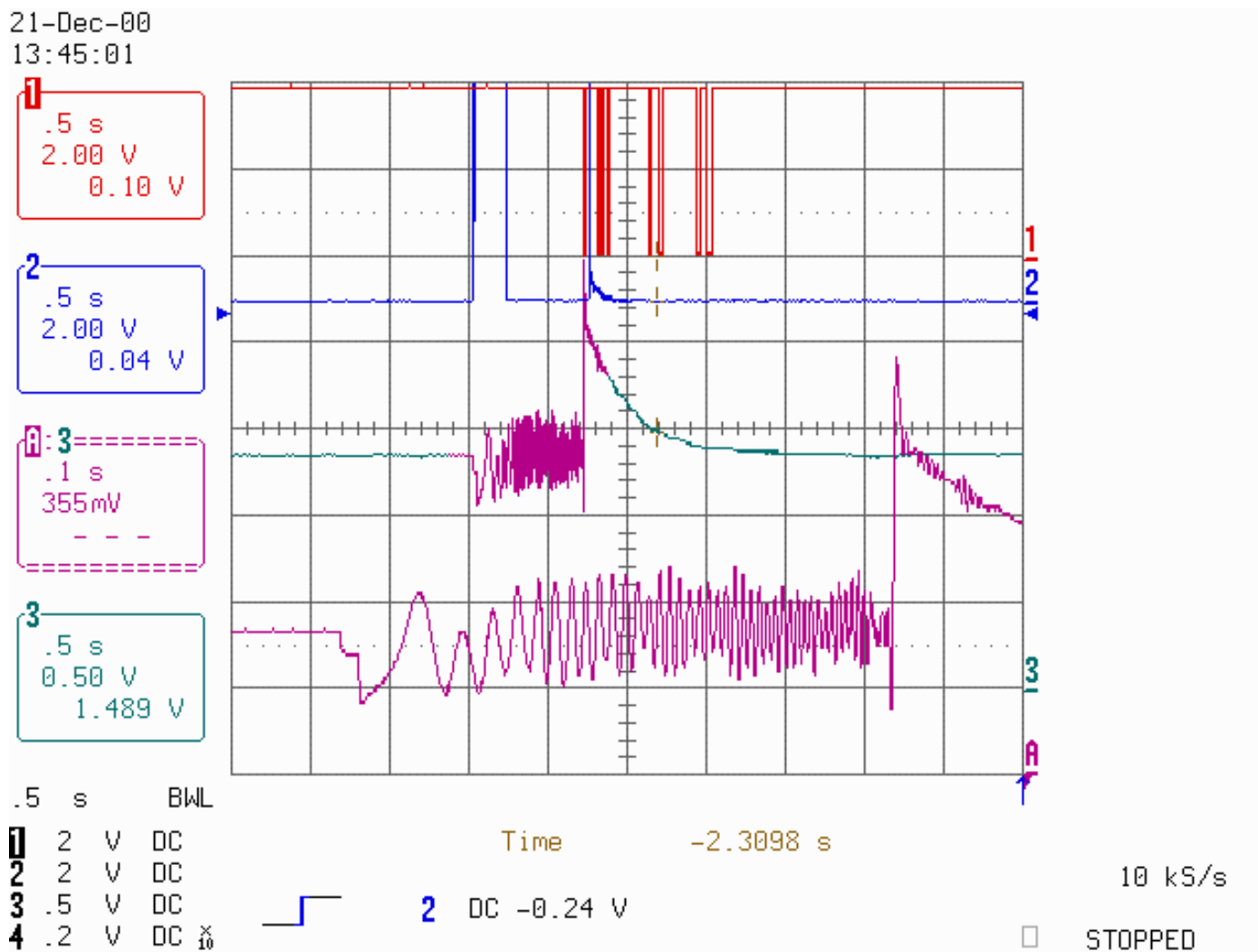



# XM784/ XM785 ET Fuze for Mortars

## *Second Env Sensor*



Calculated Pressure vs Time

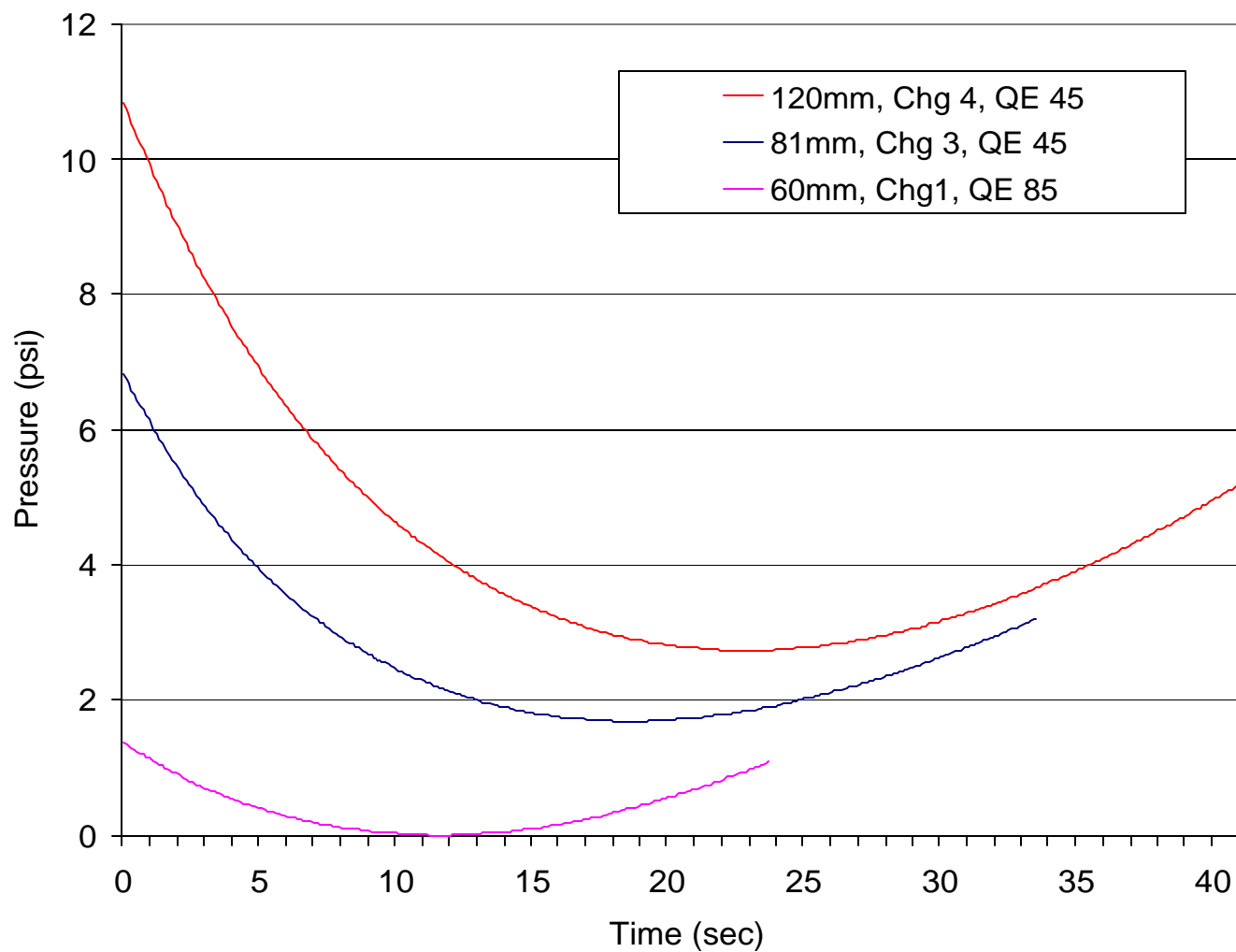



# XM784/ XM785 ET Fuze for Mortars

## *Second Env Sensor*



*(Calculated Pressure - First 3 secs of Flight)*

Calculated Pressure vs Time

Chg @ QE45	Press Range (psi)
60mm	1 1.4 - 0.9
	2 2.7 - 1.7
	3 4.2 - 2.7
	4 5.8 - 3.7
81mm	1 2.1 - 1.4
	2 4.2 - 3.0
	3 6.8 - 4.8
	4 9.7 - 6.8
120mm	1 2.5 - 1.8
	2 4.7 - 3.5
	3 7.4 - 5.6
	4 10.8 - 8.2

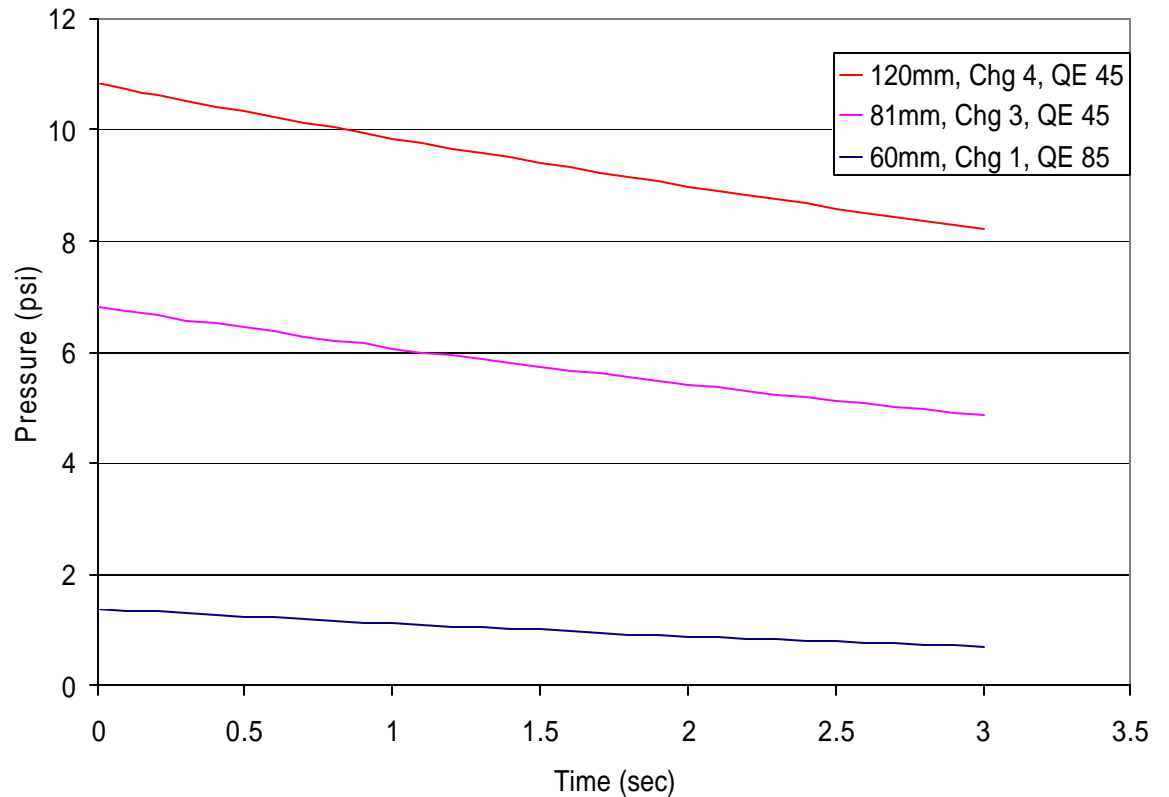



# XM784/ XM785 ET Fuze for Mortars

## *Second Env Sensor*



P-Sensor Output vs Time  
60mm, Chg 1, QE85

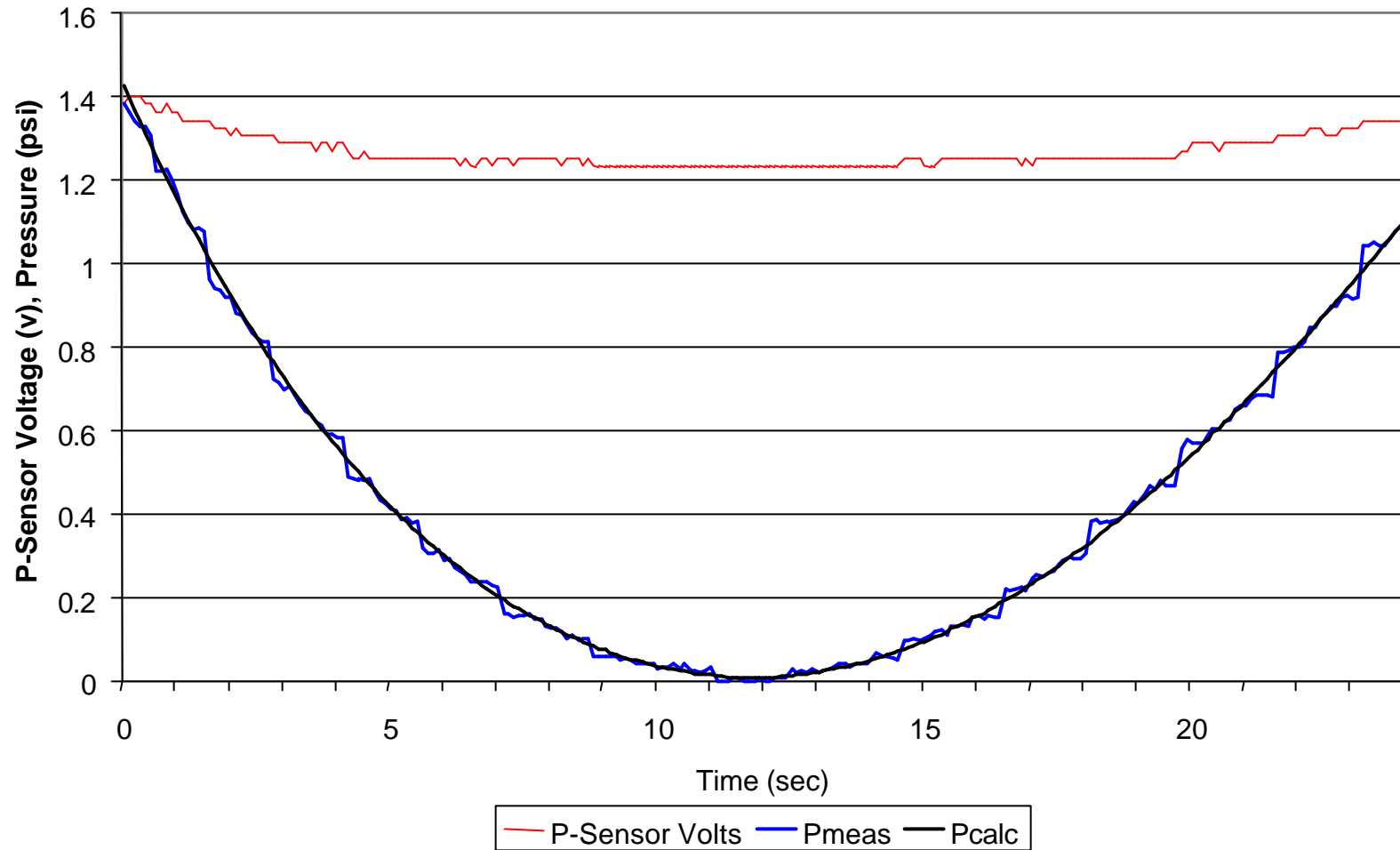



# XM784/ XM785 ET Fuze for Mortars

## *Safe and Arm Device*

---



- **Design approaches:**
  - **Command arm w/ piston actuator (stored energy)**
  - **Evaluated air powered arming**
    - removing a lock then spring driven in-line
    - directly arming the fuze
- **Zig-zag setback lock with switch closure**
- **Designed both barrier and rotor approaches**
- **Develop PRO-E layout to generate SLA hardware**



# Safety Logic Diagram - ET Fuze for Mortars

(Version B)

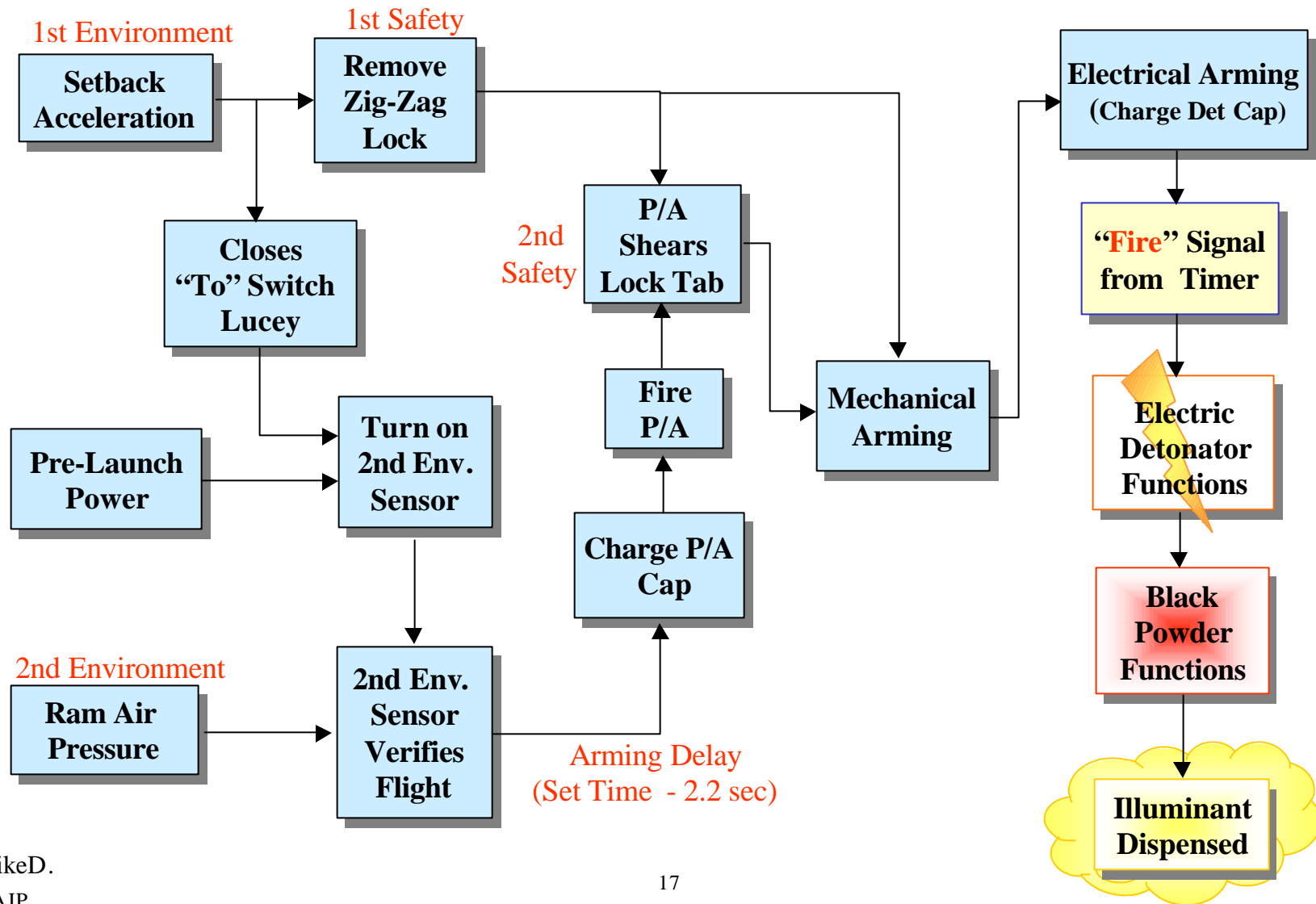



# XM784/ XM785 ET Fuze for Mortars

## S&A (safe position)

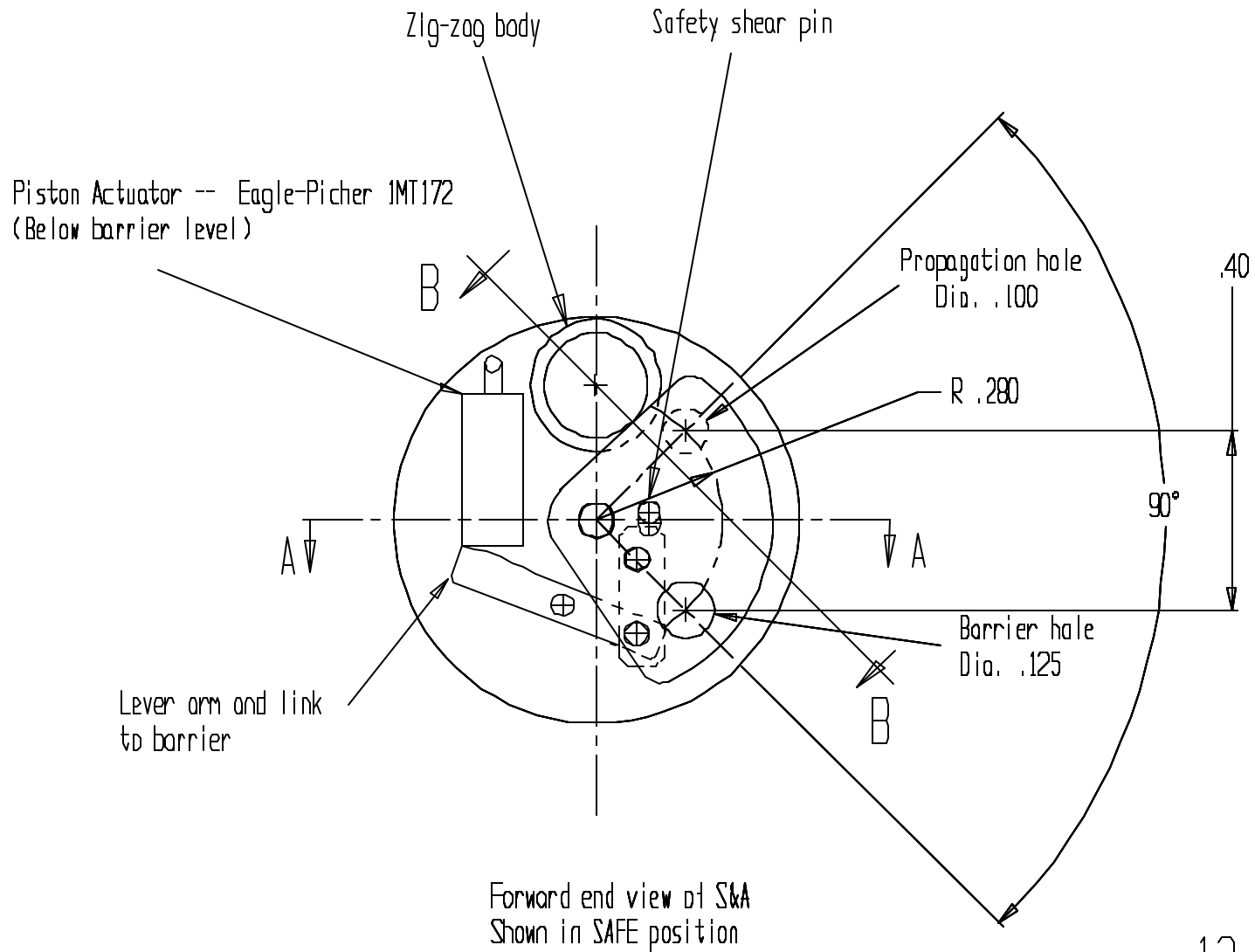



# XM784/ XM785 ET Fuze for Mortars

## S&A (armed position)

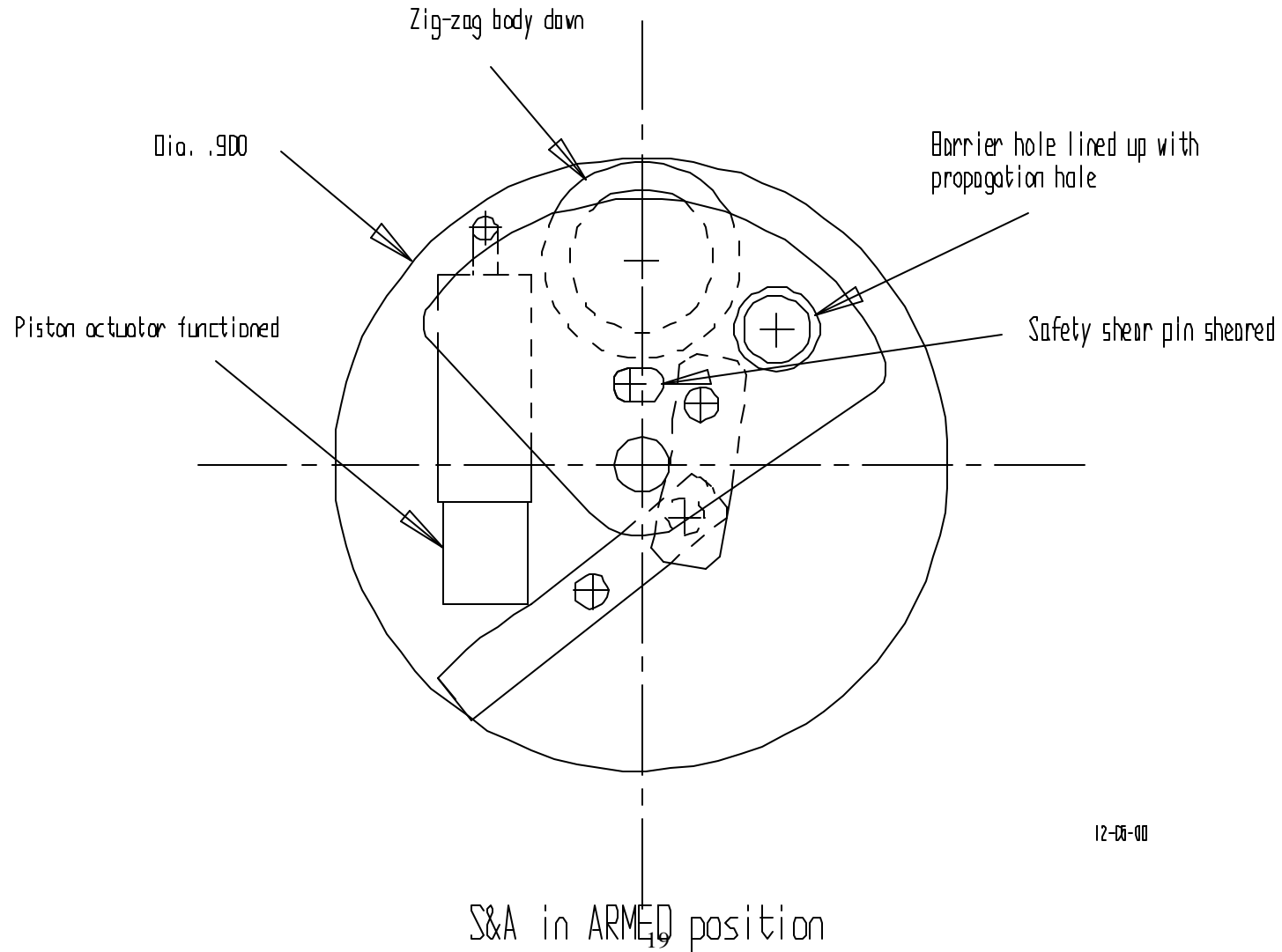

# XM784/ XM785 ET Fuze for Mortars

## S&A (zig-zag)

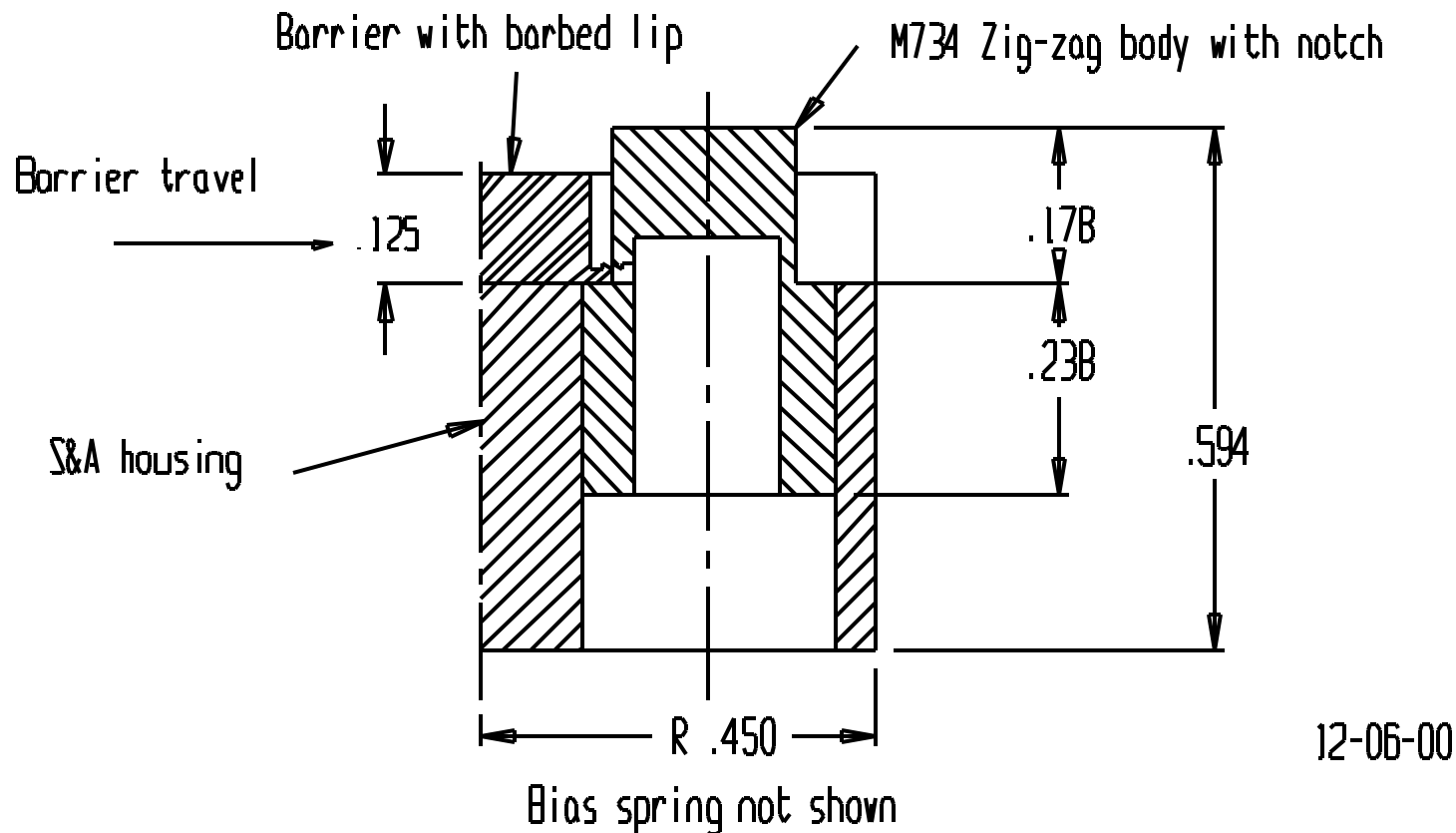

Fig. 3 Half-Section of Fail-Safe Latching Barrier for Angular, Out-of-Plane S&A Layout



# **XM784/ XM785 ET Fuze for Mortars**

## *Explosive Train*

---



- **Utilized explosive experts**
  - **Generated a matrix of possible candidates**
- **Identified a possible on-shore source for black powder**
  - **M10 to be considered as a replacement**
- **Concepts to initiate black powder:**
  - **Electric detonator or primer initiates powder directly**
  - **Electric match initiates intermediate chg (environmental stability a concern)**
- **Conduct explosive tests with candidate initiators**



# **XM784/ XM785 ET Fuze for Mortars**

## *Packaging and Hand Setting*

---



- **Generated Packaging Layouts**
  - Vertical and Horizontal Circuit Boards
  - Utilizing flex circuit concept
- **Handset scheme similar to M762**
- **Used NDI / custom LCD's (M762 Based)**
- **Developed a PRO-E model**
  - Handset concept (SLA prototype)



# XM784/ XM785 ET Fuze for Mortars

## *Packaging Model*

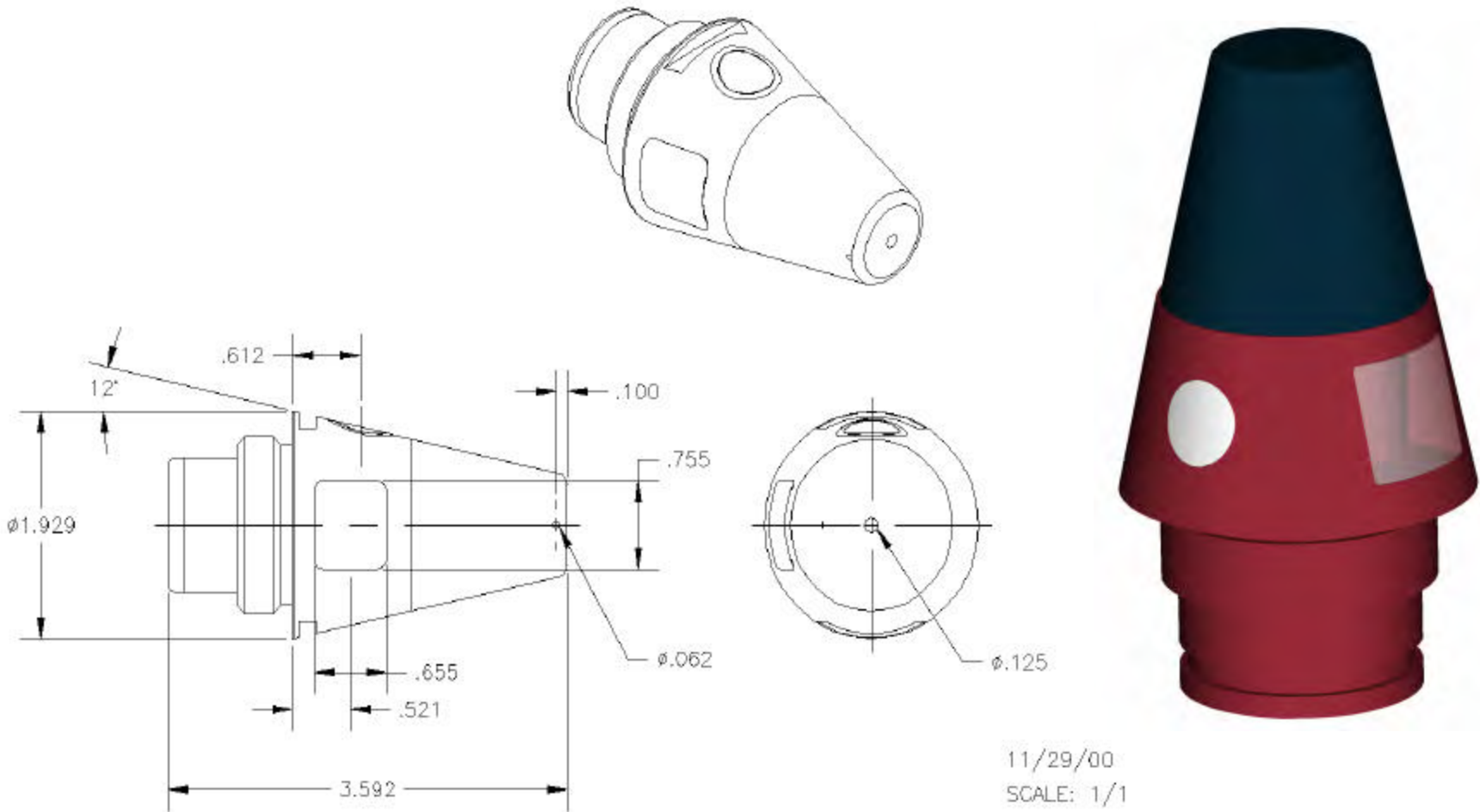

11/29/00  
SCALE: 1/1



# XM784/ XM785 ET Fuze for Mortars

## *Packaging Concept*

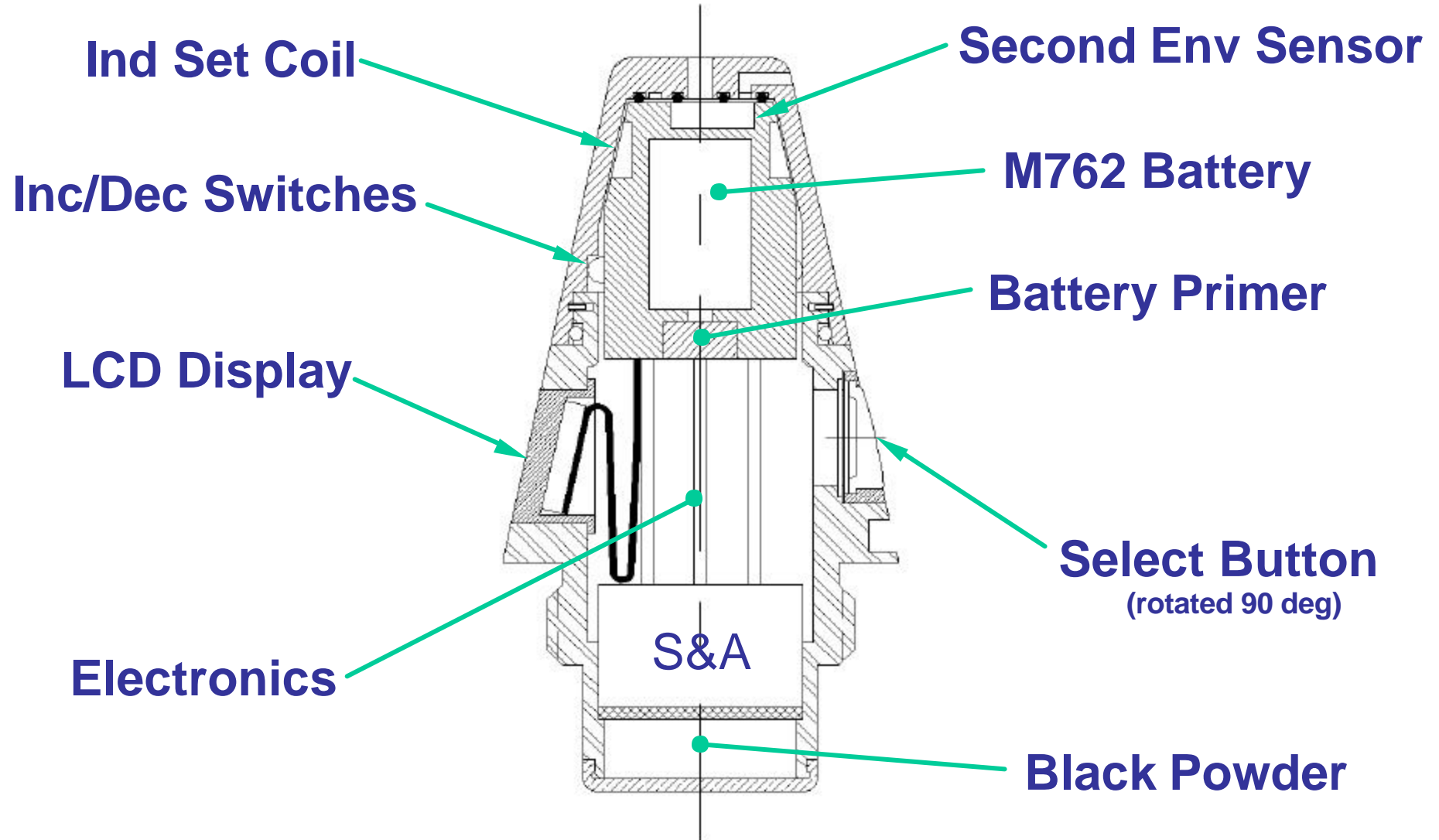



# XM784/ XM785 ET Fuze for Mortars

## *Summary*

---



- Planning Contract Award In June 2001
  - Design & Development
  - Test & Type Classify
  - First Article & Materiel Release
- Developed Initial In-House Design Concept
- Will Use Best (Cost Effective) Design Approach
  - Proposed Contractor Solution
  - Government Design
- Gov't Electronics Design Approach Follows....

# New Developments in Sensitivity Testing

---

Dr. Barry T. Neyer  
Director of Research and Development  
PerkinElmer Optoelectronics  
PO Box 529  
Miamisburg, OH 45343

NDIA Fuze Conference  
April 16-18, 2001

# Lessons Learned from Studying Birds and Bunnies Applied to Building a Better Bomb

---

Dr. Barry T. Neyer  
Director of Research and Development  
PerkinElmer Optoelectronics  
PO Box 529  
Miamisburg, OH 45343

NDIA Fuze Conference  
April 16-18, 2001

# Talk Outline

---

- Review of sensitivity testing
- Old and optimal sensitivity test designs
- Non sequential designs
- Simulation Results
- Practical Uses of New Techniques

# How Do You Test Explosive Sensitivity?

- Assume each explosive has a unique threshold:
  - » Hit it harder: explosion; hit it softer: no explosion.
- Can't measure detonator initiation threshold, only determine if a stress is smaller or larger than given a detonator's threshold.
- Can only test each sample once:
  - » Exploded samples gone; unexploded samples changed.

# A True Sensitivity Test has These Characteristics:

---

- Can test each sample only once.
- There is a unique threshold for each sample.
  - Larger stress always leads to response.
  - Smaller stress always leads to no response.
- Function of the thresholds follow known (normal distribution).
- *No duds.*

# Sensitivity Test & Analysis Used in a Wide Variety of Fields.

---

- Explosive sensitivity
- Strength of materials
- Toxicity
- Oxygen deprivation
- Pharmaceutical testing
- Radiation tolerance

# It is Easy to Determine If Simple Devices Meet Interface Requirement.

Simple Device

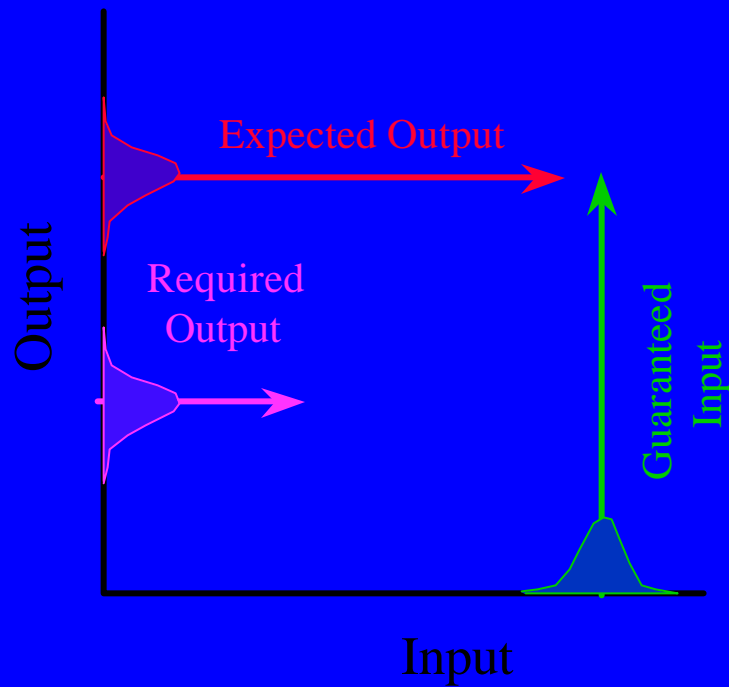

Complex Device

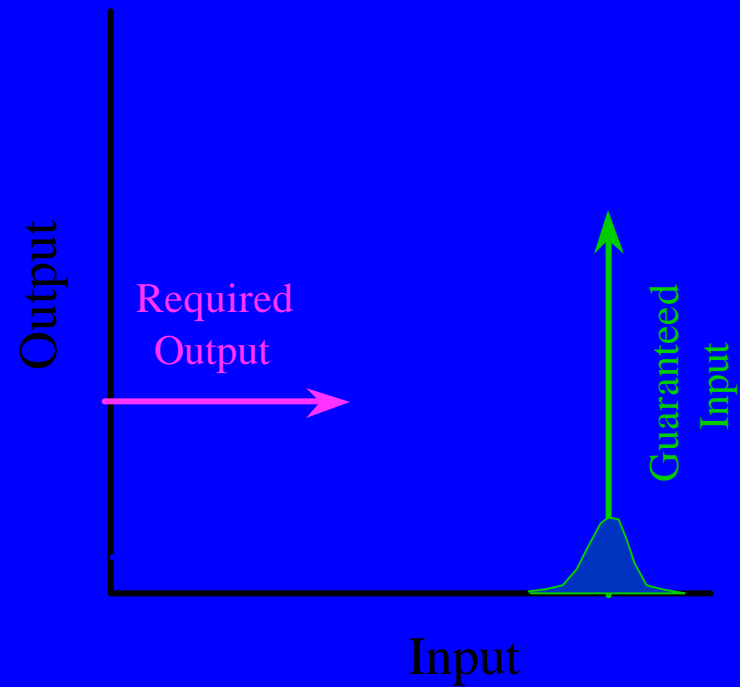

# Components Respond If the Stress is Larger Than the Threshold.

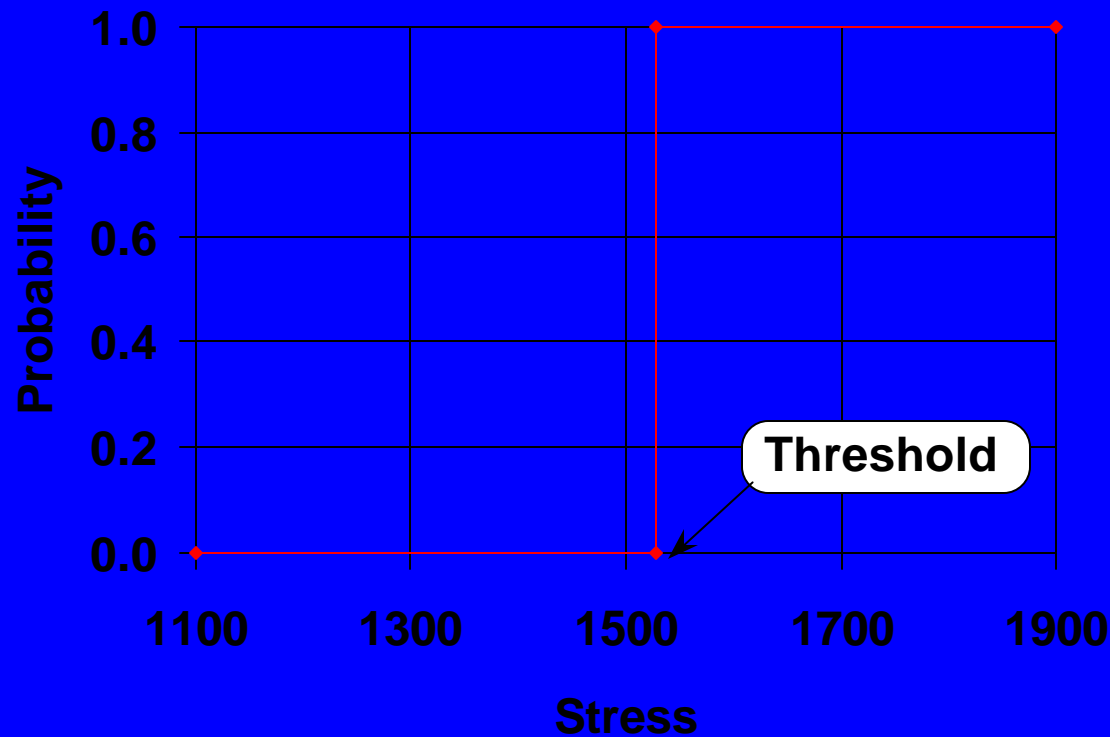

# If Component Thresholds Follow the Normal Distribution:

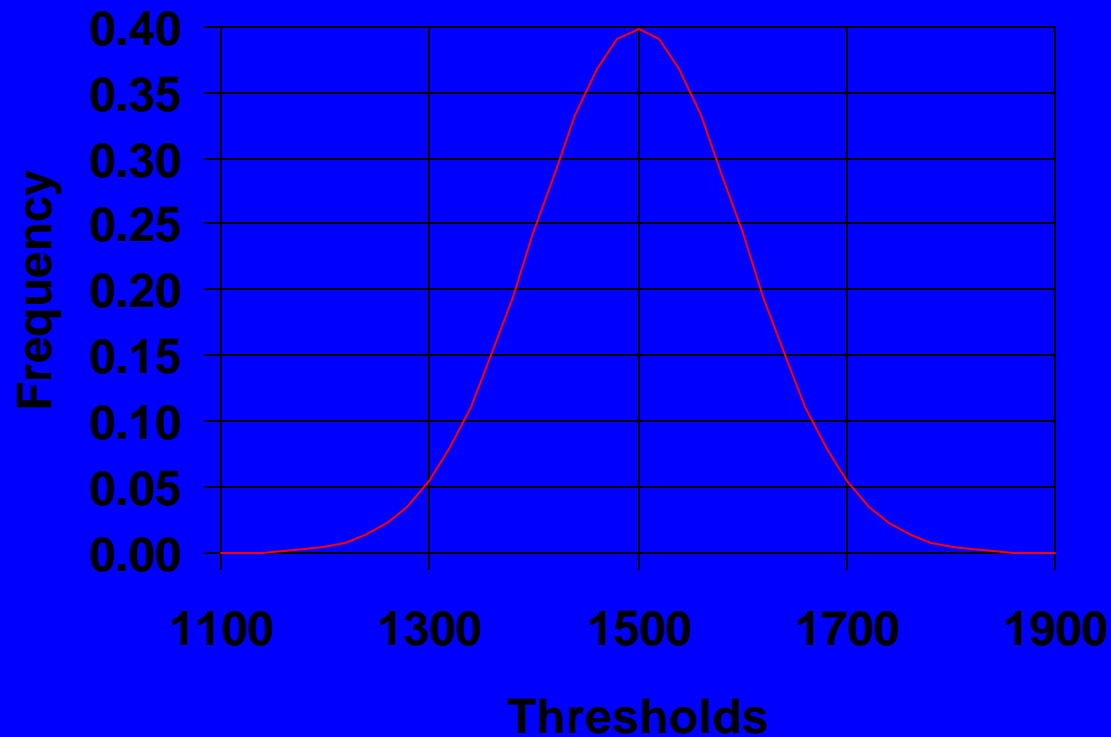

# The Probability that a Component Chosen at Random Will Respond is:

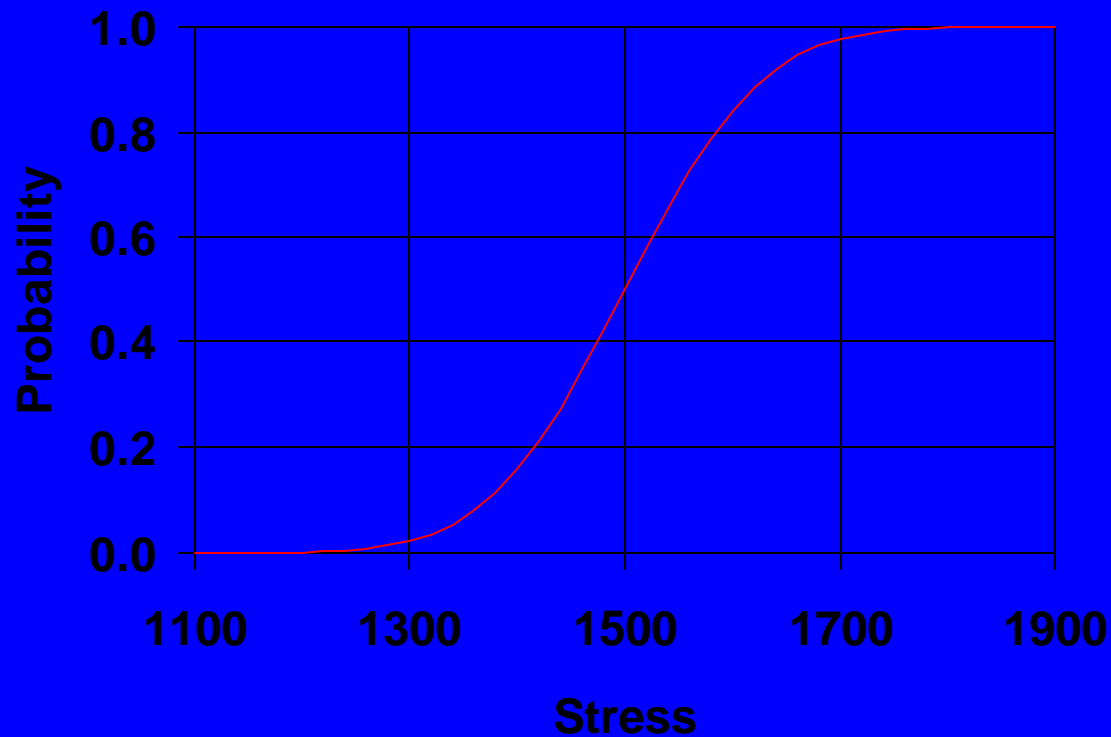

# What is an Optimal Design?

---

- All tests not created equal.
- If all responses or failures, you learn nothing.
- Amount of knowledge gained for each test is a function of test level.
- Need to pick test levels to maximize knowledge.
- If you learn the maximum amount statistically possible, it is an optimal design.

# Other Tests Were Designed Many Years Ago.

---

- Probit Test (1900). Fixed design requires many samples.
- Bruceton (1940). Designed to allow easy computation of estimates of the parameters.
- Delayed Robbins-Monro (1950). Designed to home in on mean of the population.
- Langlie (1960). Designed to give better estimates of sigma when initial knowledge was uncertain.

# The D-Optimal Test Uses a Three Step Procedure.

- Use a modified binary search to find the mean.
  - » Get 1 success and 1 failure as quickly as possible.
  - » Close in on mean.
  - » Check convergence if needed.
- Use guess for Sigma and test for maximum information.
  - » Decrease guess for Sigma until overlap.
- Update knowledge of Mu and Sigma and continue to test for maximum information.

## Most Often Explosive Components are Tested Sequentially

---

- Test equipment is expensive.
- Can only test one component at a time.
- Easy to vary stimulus level.
- Know the results instantly.
  
- Use knowledge of all N results to pick test level N+1.

# Explosive Transfer Studies are More Complicated

---

- Vary the donor or acceptor to establish the transfer reliable.
  - VariDrive or VariComp
- Must build components with different explosive density, length, etc.
- Large time delay between knowledge of requirement and delivered hardware.
- Sequential test designs not currently used.

# Similar Test Complications Exist in Biological Experiments

---

- Instead of supplying the critical energy that is sufficient to cause the device to explode, biologists supply the critical dose that is sufficient to cause the animal to die.
- It often takes days or weeks for the effects of the dose to kill the animal.
- Sequential test designs not currently used.

# Work with Groups Studying Test Designs for Birds and Rabbits Led to New Test Design

---

- The critical factor is the ability to choose several test levels at a time:
  - Time to determine effects of biological experiments
  - Time to manufacture explosive components
- Design a test that maintains advantages of present D-Optimal design, but allows choosing multiple test levels at one time.

# Modification to D-Optimal Method Allows for Choosing Multiple Test Levels

---

- Use same three population estimates, MuMin, MuMax, SigmaGuess
- First time(s) through spread out test levels uniformly
- When close to SigmaGuess spread out between 2 D-Optimal points
- When levels overlap, place levels at 2 D-Optimal points

# Simulation Shows that Modified D-Optimal Method is Very Efficient

- Perform simulation with realistic knowledge of Mu and Sigma
  - Know Sigma within a factor of 2
  - Know Mu within 2 standard deviations
- Look at Mu, Sigma, and All-Fire estimates
- Variance of estimates indicates efficiency
  - Variance has  $1/N$  dependency

# Simulations of 1000 Repetitions Were Performed for 27 Cases

Mu Relative Standard Deviation

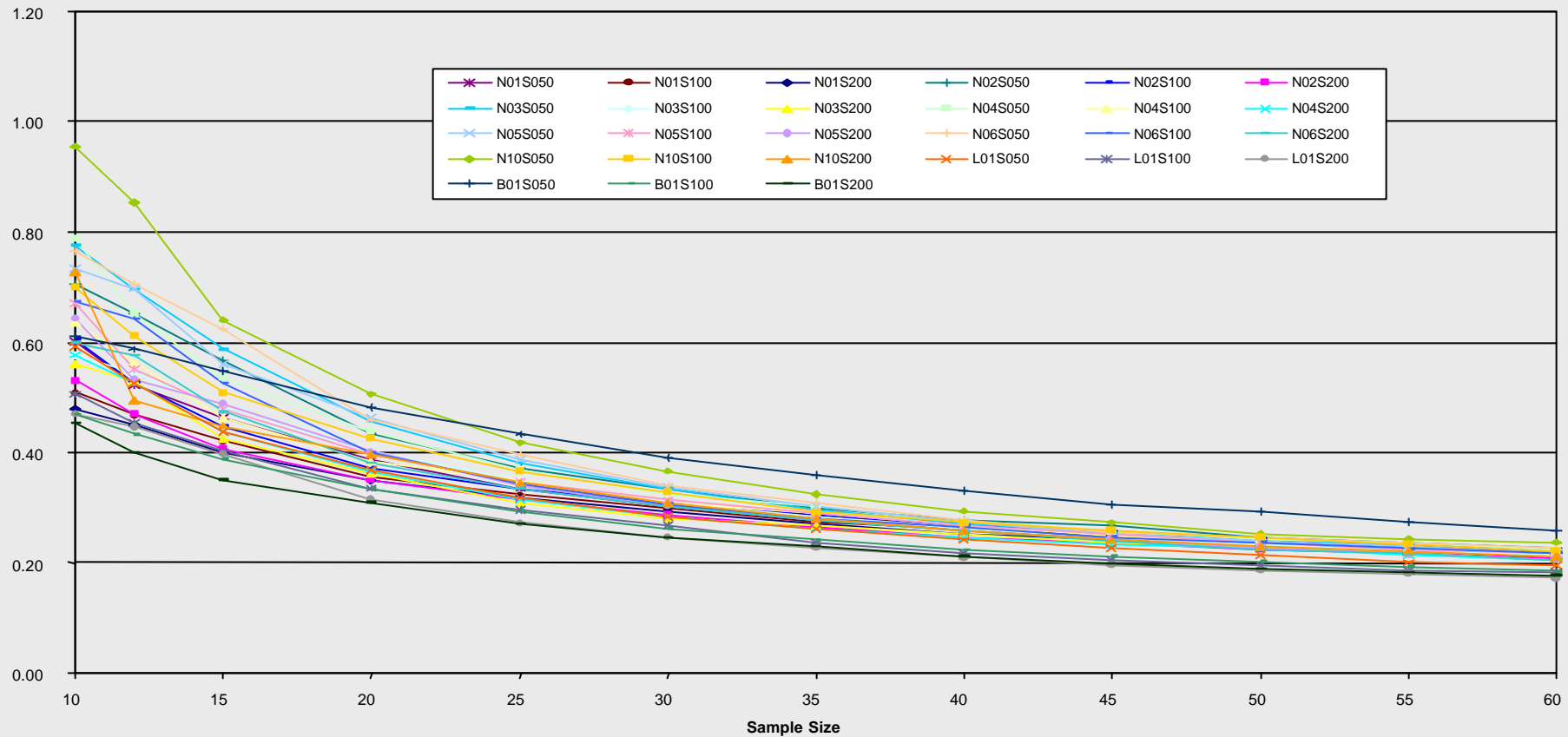

# Little Change in Mu Efficiency when Picking Up to 10 Tests Simultaneously

Minimum Inverse Mu Relative Variance

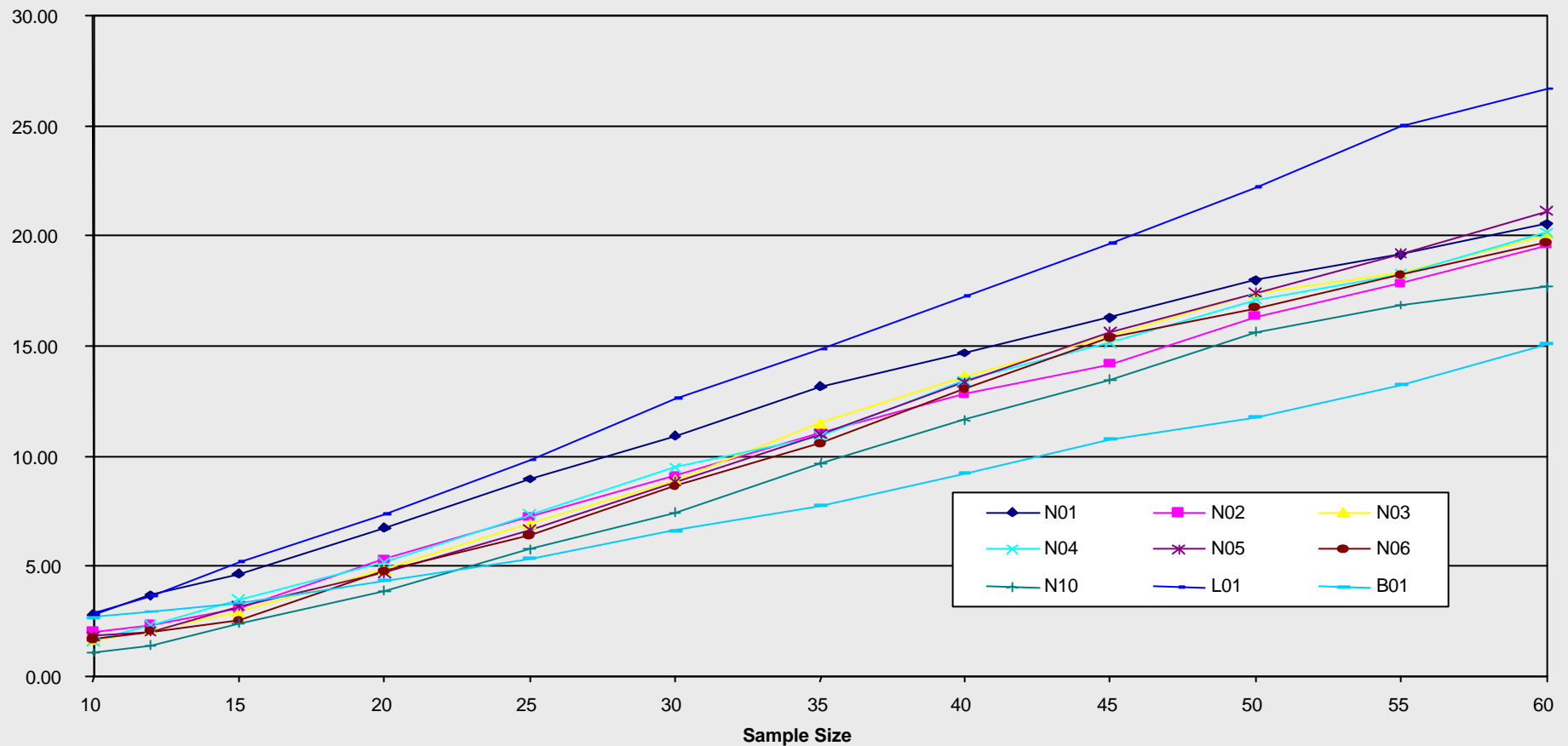

# Little Change in Sigma Efficiency when Picking Up to 10 Tests Simultaneously

Minimum Inverse Sigma Relative Variance

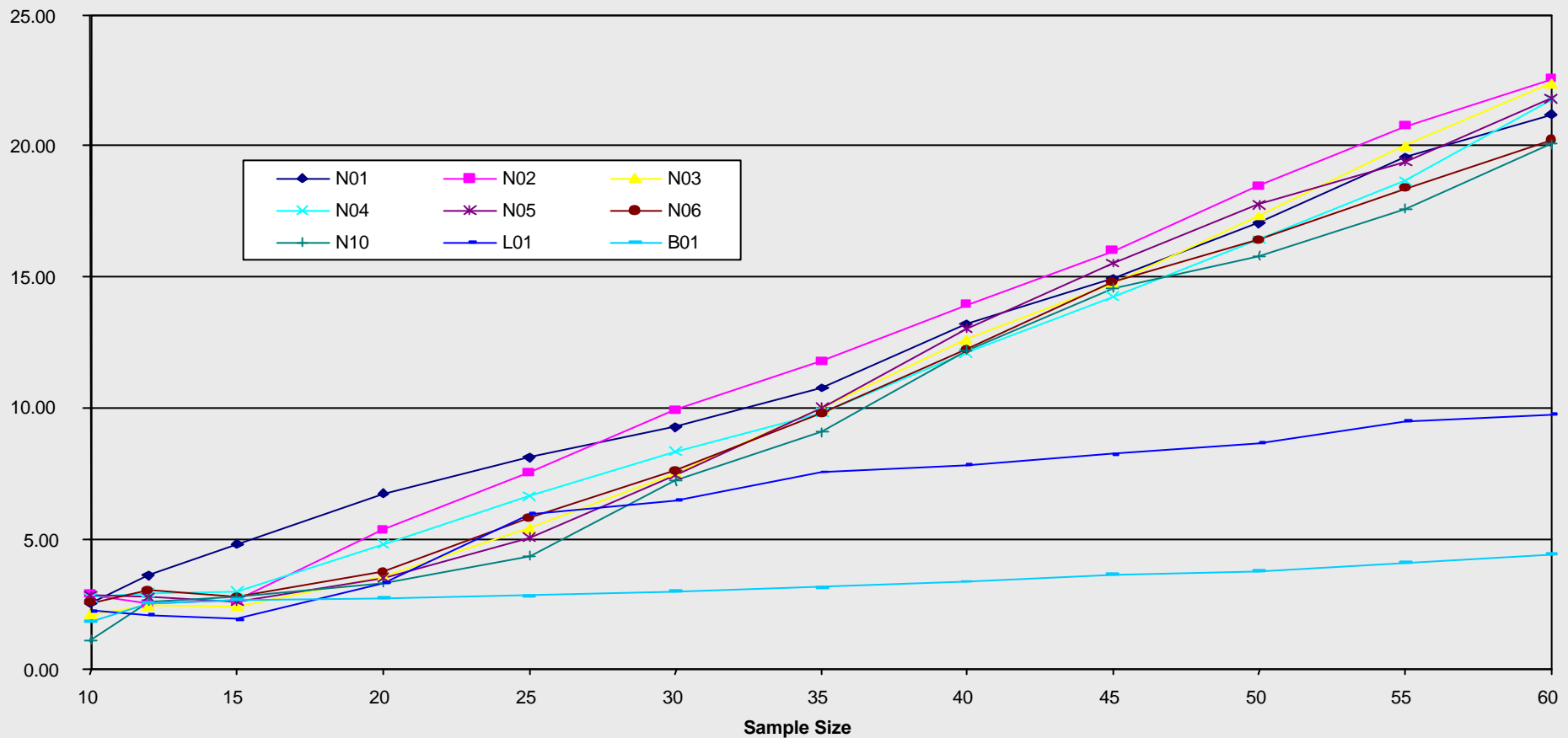

# Little Change in All-Fire Efficiency when Picking Up to 10 Tests Simultaneously

Minimum Inverse Probability Relative Variance

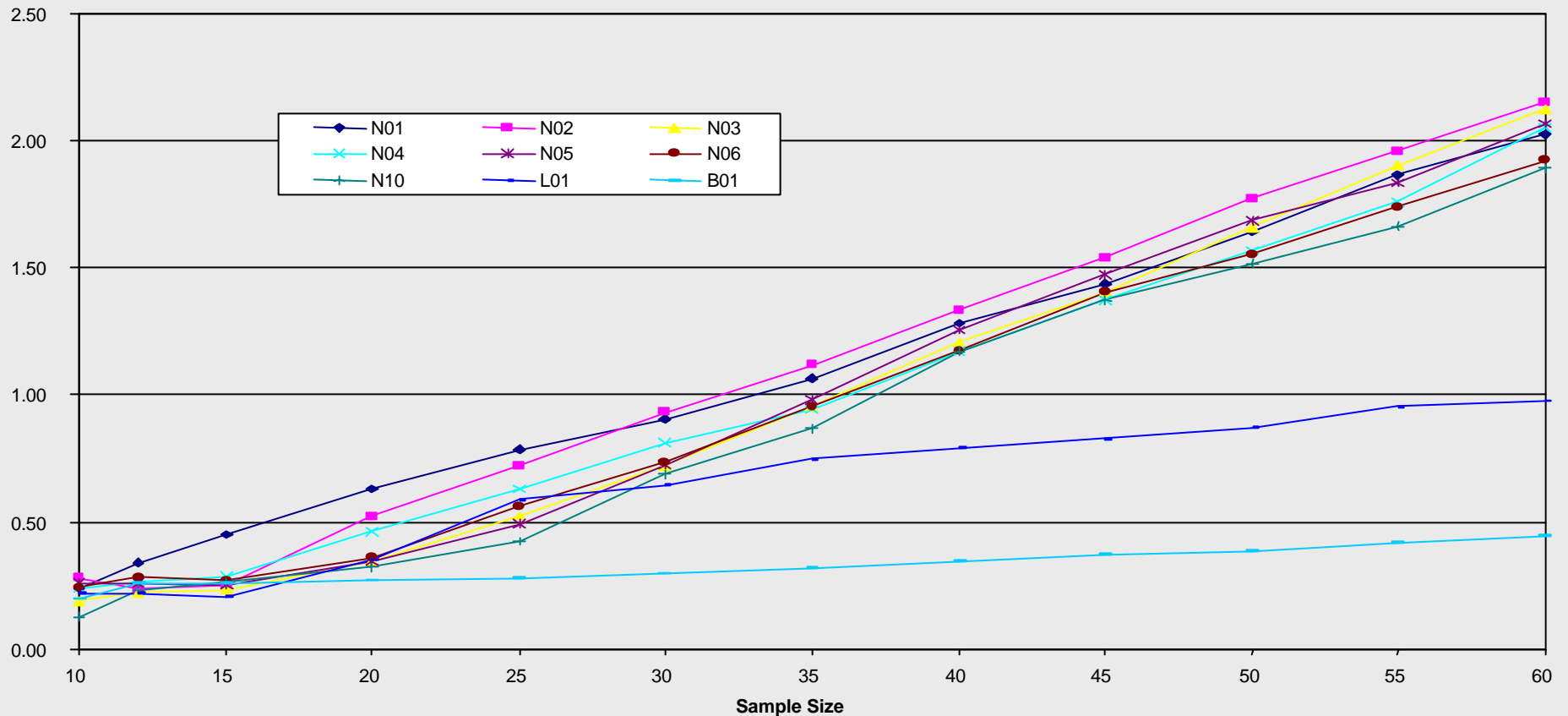

# The Decrease in Efficiency Can Be Estimated

- As long as there are at least 4 steps (stages)
  - Simultaneously testing  $S$  units at a time gives similar results to testing  $S-1$  less units. (Testing 25 units picking 5 test levels at a time gives similar results to testing 21 one at a time.)
- Mu, Sigma, and All-Fire levels are all better when picking test levels 1 or a few at a time.
  - More simulation with 10,000 repetitions needed to fine tune result

# The Modified D-Optimal Test Method Can Be Used In Many Applications

---

- Whenever it takes time to produce the test levels
  - VariDrive and VariComp experiments
- Whenever the test results are not known for some time
  - Maximum no damage current tests

# A MODULAR APPROACH TO ELECTRONIC FUZE DEVELOPMENT

MIKE TUCKER



# PRESENTATION CONTENTS

- Company Background
- International Fuzing Trends
- Customized Fuze Features
- Risk Areas in Artillery Fuze Development
- Development Approach
- Fuze Components
  - Customized Features
- Derived Range of Fuzes
- Future Possibilities
- Summary
- Conclusion



# FUCHS ELECTRONICS - BACKGROUND

- Privately owned South African Company
- Designs and Manufactures Electronic Fuzes for Tube-Launched Ammunition
  - Artillery Fuzes
  - Rocket fuzes
  - Naval Fuzes
  - Mortar Fuzes
  - Fuze Setting Systems
- Staff of Approx. 280
- Supplies Internationally to Ammunition Suppliers and end-users
- Almost 100% of Production is Exported



# FUZE PRODUCTION PERCENTAGES BY PRODUCT TYPE \*

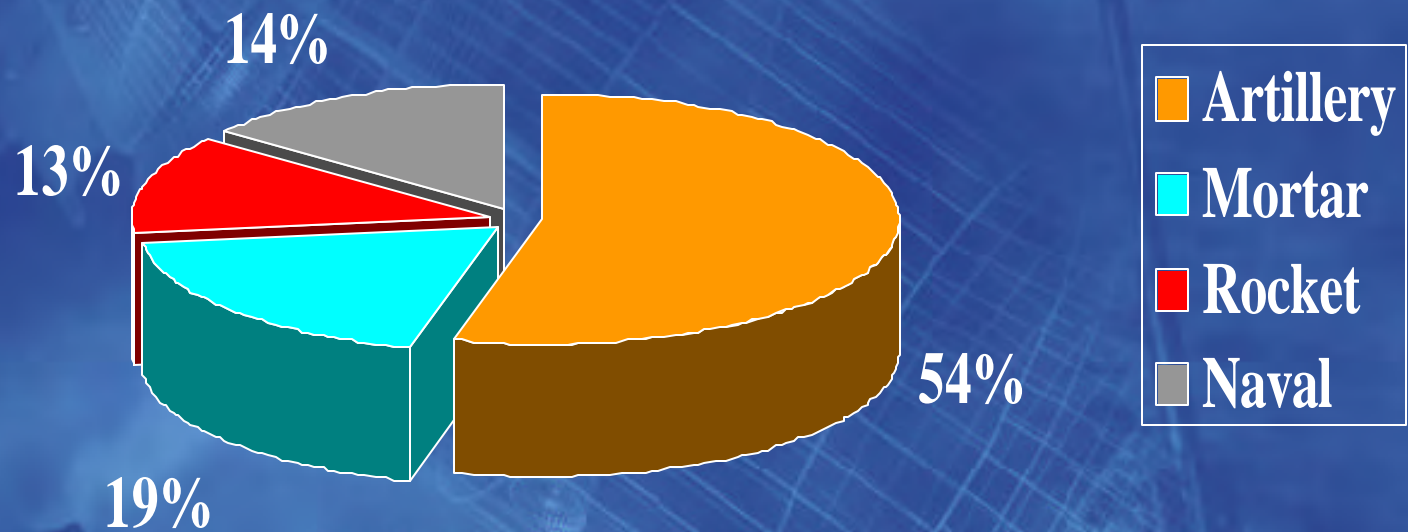

\* Based on sales of past 20 Years

# International Artillery Fuzing Trends

- Customer Requirements:
  - Short Timescales – Typically 4 to 6 months to Production
  - Reduced Production Volumes
  - Customized Features
  - Proven Safety, Reliability and Qualification Status
  - Very High Probability of Project Success



# Customized Fuze Features

- Safety Times
- Burst Heights
- PD Backup feature and its Arming time
- Multi Role Usage e.g. Proximity, Time, PD, PD Delay
  - With or Without Delay Function
  - Post Impact Delay Time
- Function Switch
- Inductive Settable Features
- On-Board Displays of e.g. Time Set
- Delivery Timescales are always shorter than needed for a full development cycle !



# Risk Areas in Artillery Fuze Development

- Component breakage due to launch stresses at Highest Charges
- Survival of in-flight temperatures and pressures
- Trajectory Bursts due to:
  - Noise effects
  - Vibration
  - Ammunition instability
- Compatibility with Rocket Assisted or Base bleed Ammunition
- High Cost of Dynamic Proofing
- Lead times of Electronic components

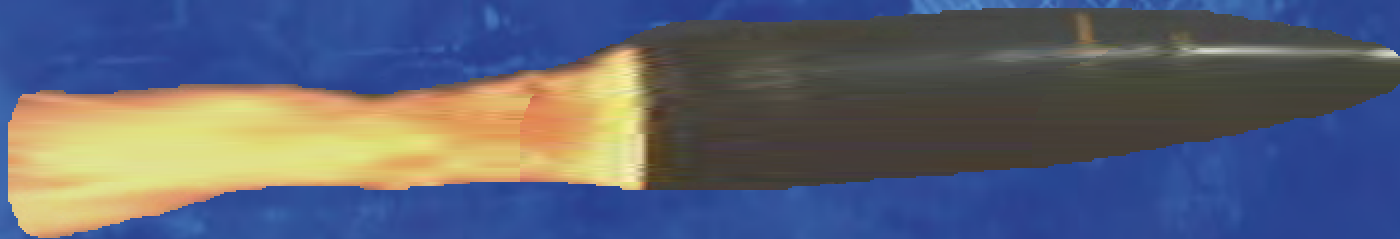

# Development Approach

- To satisfy the requirements, the following approach has been adopted successfully:
  - Use Integrated Development Teams within the company:
    - Electronics Engineers
    - Mechanical Engineers
    - Pre-Production Representatives
    - Instrumentation Development Engineers
    - Quality Control Engineers

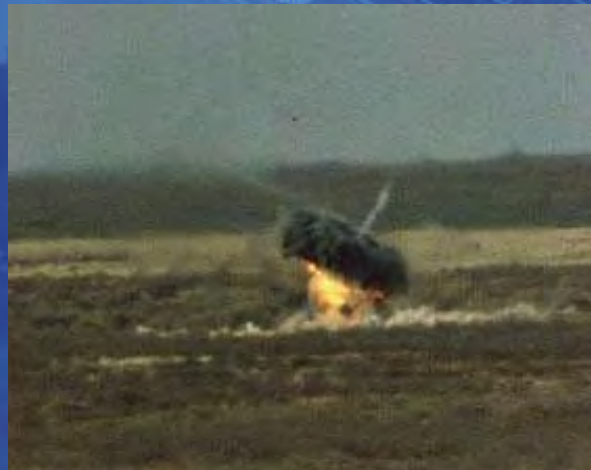

# Development Approach - II

- Use of proven “Building Blocks”
- In-house Prototype Manufacturing Department
- Regular Dynamic Proofing
  - Use of In-Flight Telemetry
  - Easy access to well instrumented Proof Ranges
- Development of Dedicated Test Instrumentation

```
Sync. No. 7989 L9  
Fuze No. 0065535  
Mode:PX Hi 200.0  
Count Down: 108s  
Volts=27.2 SFM04  
Delta=05 Gain=00
```



**FUCHS**  
ELECTRONICS

# Typical electronic fuze components

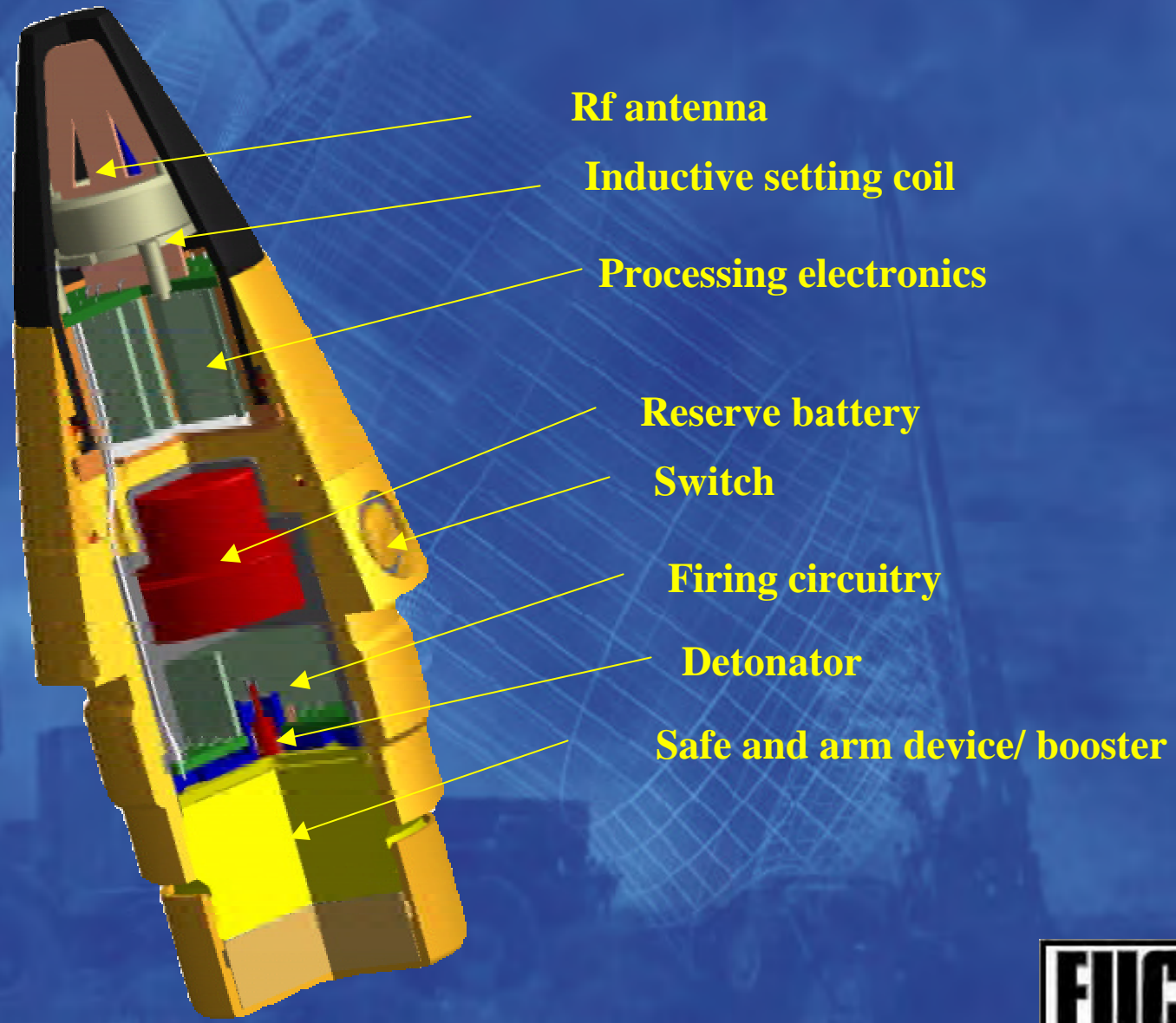

# Electronic head assembly

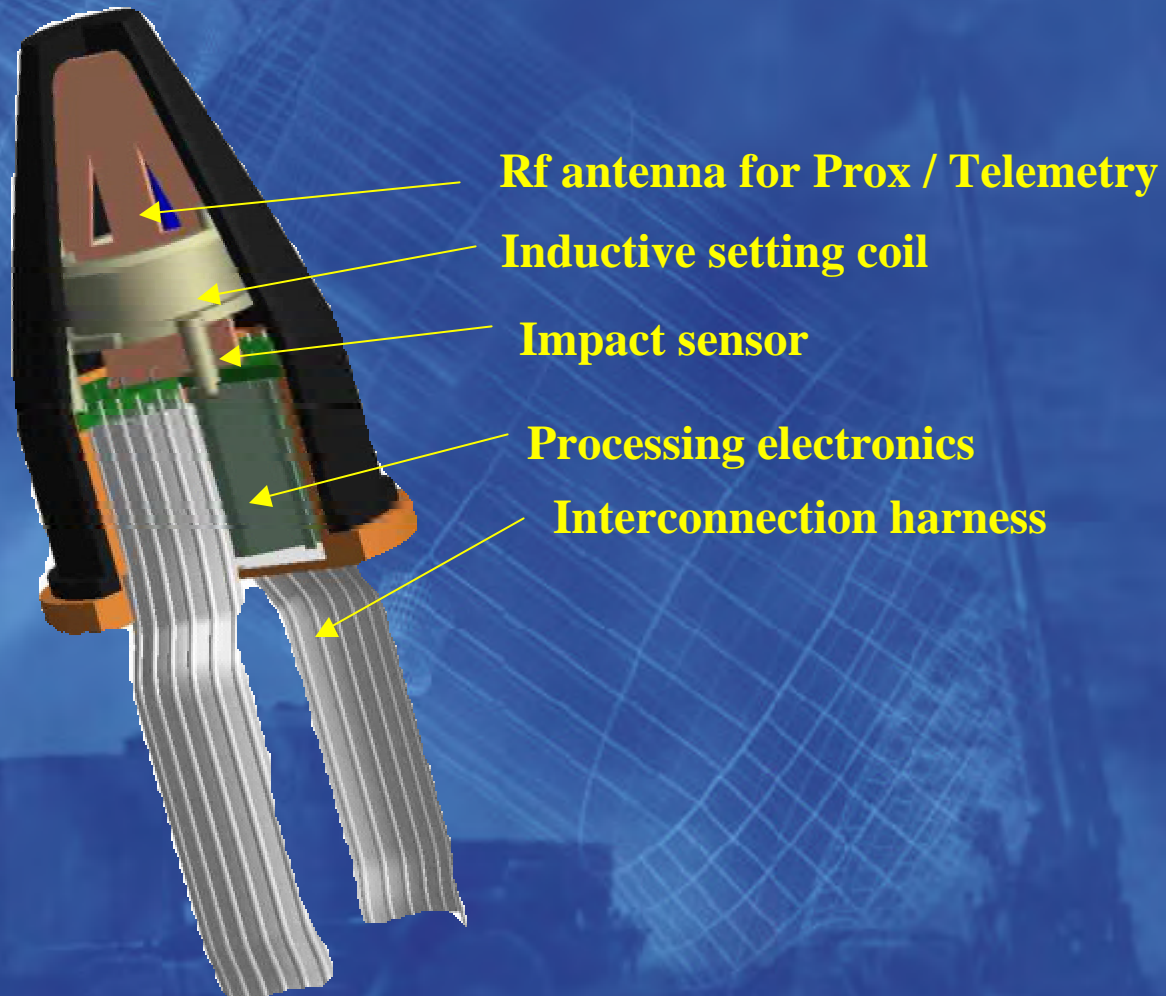

# Electronic Head Assembly

- **STANDARD FEATURES:**
  - Microprocessor Controlled
    - Software programmed during final assembly
  - Inductively Settable or Factory Set Only
  - DATA stored in EEPROM
    - Re-Writeable via Inductive coil interface
    - Mission Settings, e.g. Proximity with 6.5 sec Safety time

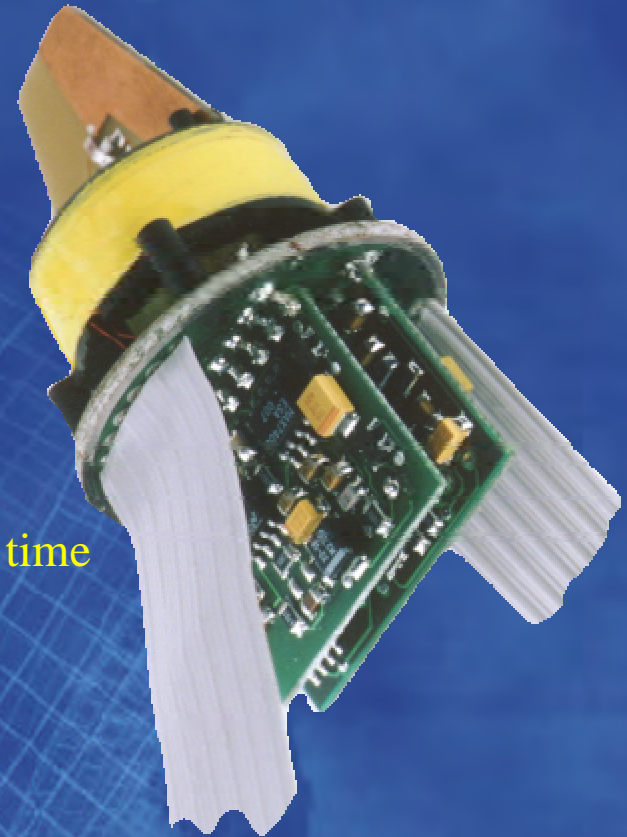

# Electronic Head Assembly

- CUSTOM FEATURES
  - Proximity / Time / PD Functions
    - Safety Time for PD Backup
    - Proximity Enable / Safety Time
    - Proximity Algorithm
    - Burst Heights
  - Switch Setting
  - Production / Engineering Settings
    - RF Transmission Characteristics
    - Signal Processor Characteristics
    - Telemetry Features



# Lower module assembly

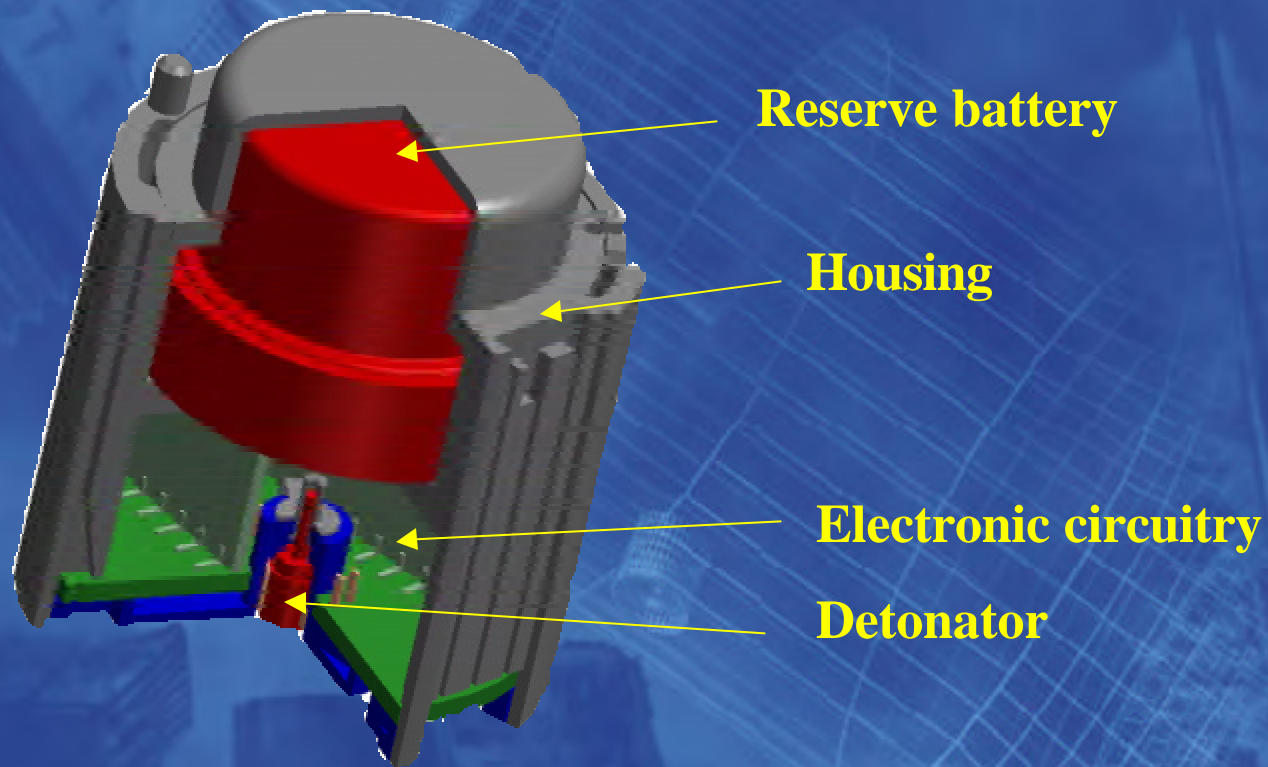

# Lower Module Assembly

- FEATURES:
  - Fire circuitry
  - Power supply circuitry
  - Detonator interface
  - Interface to switches or displays
- CUSTOM FEATURES
  - Fire circuit safety times
  - Post impact delay time

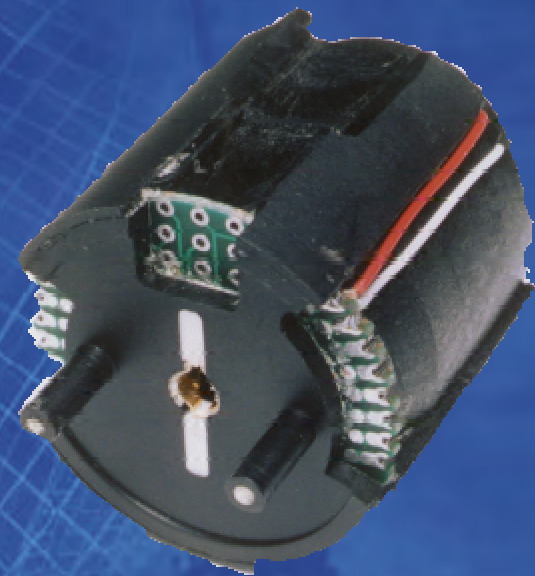
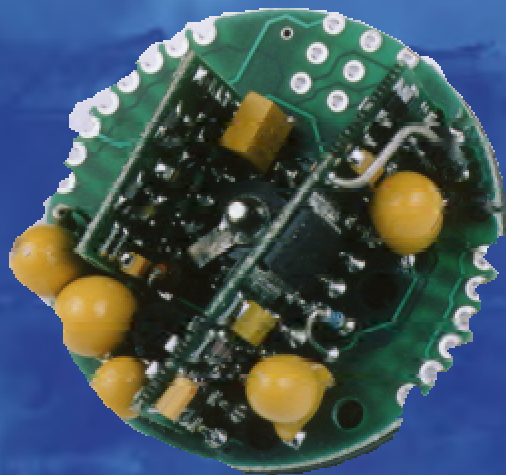

# General construction



Nose cone

Fuze body

Push buttons

Display

Safe and arm device



Display



Mode switch

# General Construction

- FEATURES:
  - Houses all sub-assemblies
- CUSTOM FEATURES
  - Switches for MOFA or PROX/PD
  - Buttons for time fuze setting
  - Display for time fuze setting
  - Safe and arm device
    - 40m or 200m Options



DISPLAY

SAFE AND ARM DEVICES



# Derived Range of Artillery Fuzes



ARTILLERY PROXIMITY,  
ELECTRONIC PD / DELAY

AND MOFA FUZES

FUZE SETTER

ARTILLERY TIME FUZES

**FUCHS**  
ELECTRONICS

# Future Possibilities

- Further Enhance Flexibility by:
- Mid – Life Software Upgrade to Fuzing Systems
  - Depot Modification of Microprocessor code via Inductive Setting Coil
  - (Currently done by hard wiring at final production stage)
- Examples:
  - Convert Proximity Fuzes to Multi-Role Fuzes
  - Upgrade ECCM features as a software retrofit
  - Improve reliability by use of improved signal processing



# Summary

- Benefits of a modular development approach:
  - Significantly reduced number of Dynamic Firings
  - Reduced Development Time
  - Reduced Technical Risk
  - Increased Manufacturing Flexibility
    - Different Fuzes can be produced with the same material
  - Reduced Life cycle cost
    - Software only Mid-life upgrades
  - Re-work or Re-use of fuzes without physical disassembly



# CONCLUSION

A modular approach to electronic fuze development assists in reducing 'time to market' and development costs as well as reducing risks involved in adopting untested hardware

**FUCHS**  
ELECTRONICS  
Dependable Fuze Technology

**FUCHS**  
ELECTRONICS



# **Storage Reliability of Reserve Batteries**

**Jeff Swank and Allan Goldberg  
Army Research Laboratory  
Adelphi, MD  
301-394-3116  
[jswank@arl.army.mil](mailto:jswank@arl.army.mil)**



# At Issue

- Items developed for munitions have a 20-year shelf life requirement over a wide temperature range
- Developers need to “prove” storage reliability
  - Actual documentation preferred
- Science can be difficult, time-consuming, and costly

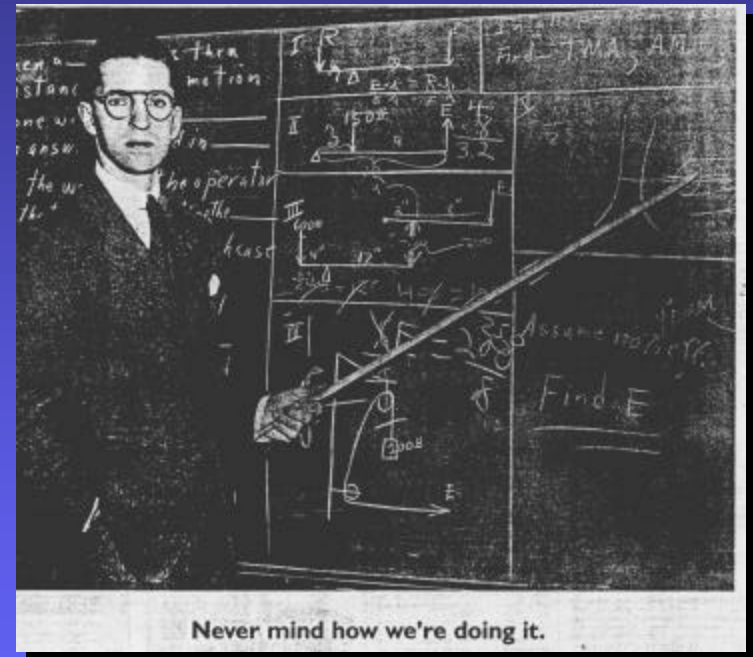



# Reservoir Evolution

- **Army and Navy used Pb/HBF<sub>4</sub>/PbO<sub>2</sub> reserve batteries with glass reservoirs**
- **Over time it was discovered that batteries became more sensitive to activation when dropped**
- **Glass was being attacked by the aqueous electrolyte**
- **Drove change to copper dash-pot design**



# Reservoir Evolution



**PS112 Ampoule**

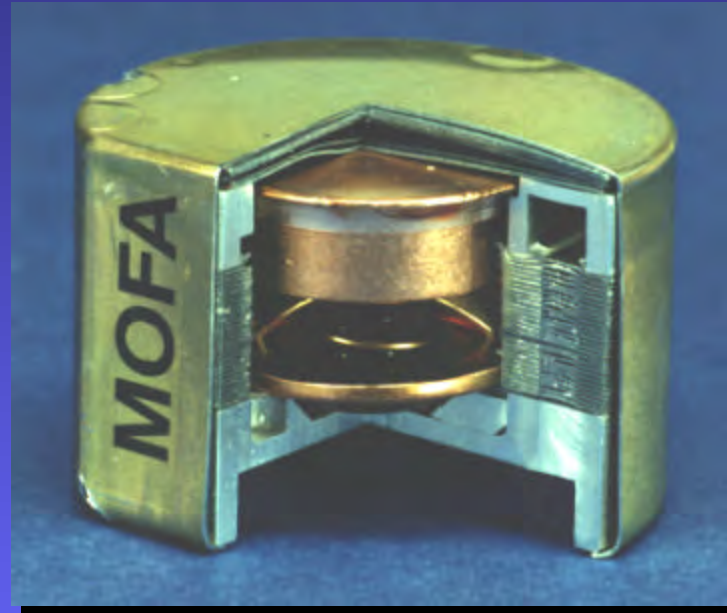

**ARL MOFA battery  
(sectioned)**



# A Common Approach

- **Put samples in high-temperature storage**
  - **Rule-of-Thumb: reaction rates double with every 10°C increase**
    - **1 year at 65°C = 16 years at 25°C**
- **Periodically pull samples and test battery performance**
- **Analytical work kept to a minimum**



# Potential Drawbacks

- Previous slide predicts aging at 25°C
- How to accelerate aging at high temp conditions?
  - Increase beyond 74°C (165°F), but risk introducing new effects or reactions
  - Increase study time
- Might miss subtle changes that indicate trouble
- Might mask problem altogether



# PS115: A Case Study

- **Dual-fluid, copper reservoir design**
  - **Fluoboric acid electrolyte**
  - **Methylene bromide (non-conductive, more dense)**
  - **Sequenced release of fluids**
- **Developed in 1964, used in M732 fuze starting in 1978**
- **Initial studies of reservoir/electrolyte materials indicated they were compatible**
- **Accelerated aging at 71°C (160°F) indicated no problem**



# PS115 Section

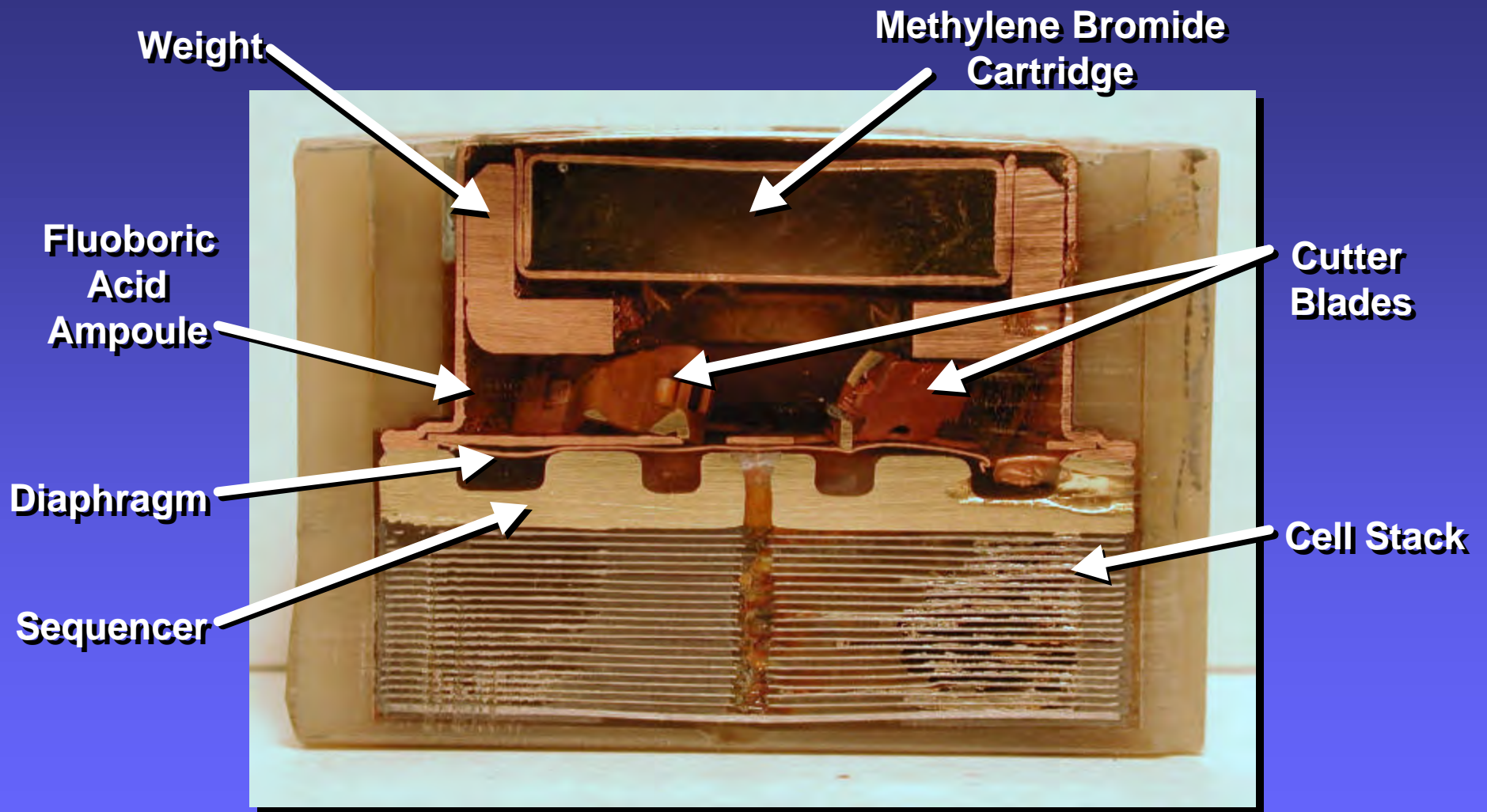



# PS115: Problems Detected

- Production began in 1978
- Five years later, leakage was noticed in engineering samples at HDL
- Further investigation revealed that virtually every lot produced prior to Nov 1980 contained leaking batteries

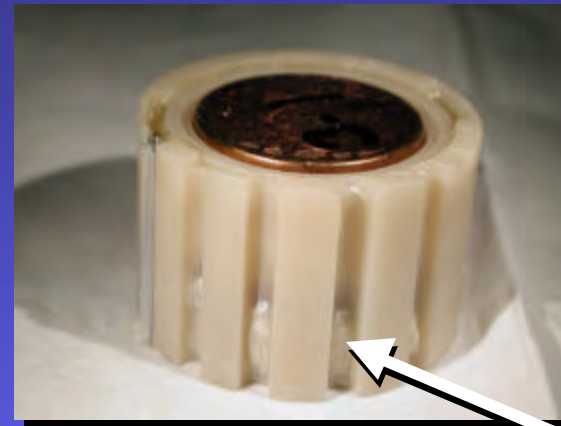



# PS115: Investigation Results

- Leakage started earlier and affected a larger percentage of units as temperature increased up to about 60°C (140°F)
- Beyond 60°C, incidents of leakage decreased sharply, essentially reaching zero at about 71°C (160°F)
- Methylene bromide fueled a complex series of reactions with the other reservoir materials
- Above 71°C, increased solubility of copper salts prevented the unique circumstances that caused pitting corrosion and leakage
- High-temp bake-out of reservoir was initial “cure”



# A Better Approach

- Store at at least three temperatures
  - determine reaction rates
  - detect changes in behavior
- Use analytical chemistry and optical techniques to measure physical changes
- Determine what is happening, and how fast

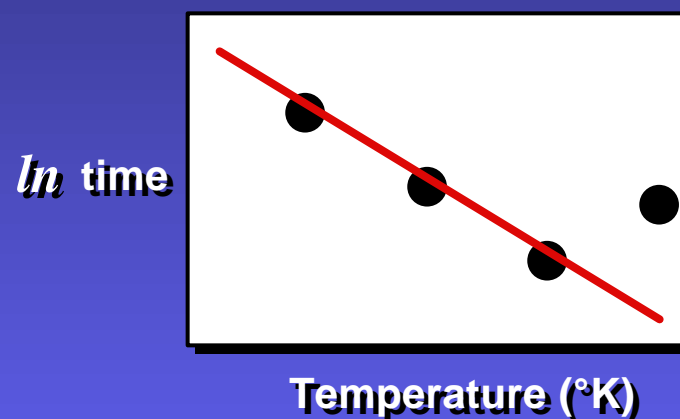



# Change in Chemistry

- **Lead is pretty much history in munitions batteries**
  - Environmental concerns, lack of business
  - Non-availability of some critical materials
- **Lithium Oxyhalides are systems of choice**
  - Good history with single-cell, glass reservoir (barrier munitions, M762 time fuze)
  - Starting to see metal reservoirs in artillery applications (MOFA)
  - Missiles use metal reservoirs
    - 10-year shelf life?
    - Treated better?



# Concerns with Oxyhalide Electrolytes

- **Very few materials are compatible**
- ***Extremely* moisture sensitive**
  - Reaction products include HCl, SO<sub>2</sub>, Cl<sub>2</sub>, H<sub>2</sub>SO<sub>4</sub>
- **Some additives/constituents can cause problems**
- **Can also be affected by light and heat**
- **Issues have been raised on several current programs**
  - **Solid forming in electrolyte?**



# From the Literature

- ***Generally speaking, several metals exhibit good corrosion resistance to neutral electrolytes (LiAlCl<sub>4</sub> in thionyl chloride and sulfuryl chloride)***
- **Using AlCl<sub>3</sub> creates a much more corrosive environment (acid electrolyte)**
- **Of concern in metal containers:**
  - heat-treated (welded) areas
  - stressed areas
  - crevice regions
  - metal couples



# Some Lessons

- **General information is nice, but best to evaluate specific designs**
- **Great care is required to collect and prepare samples for analysis**
- **Electrolyte additives should be thoroughly studied prior to implementation**



# Recommendations

- **Start thorough compatibility studies as early as possible, using representative hardware**
- **Assume studies will take some time and careful planning and execution; quick results likely to be bad news**
- **Need to understand potential failure mechanism(s): PS115**



# ARL's Contribution

- **Retain in-house Government expertise**
- **Support contractor's development efforts**
- **Conduct complementary testing and analysis**
- **Work to ensure the product meets the Government's requirements**
  - **Need to independently assess the proposed technology**
  - **Government needs to be an educated buyer**



# **Miniature Thermal Batteries for Low-Current Applications**

**Frank C. Krieger  
301-394-3115  
fkrieger@arl.army.mil**

**Army Research Laboratory  
17 April 2001**



# Present Thermal Battery Technology



1. Thermal batteries have been miniaturized for high-current (1 to 4 A/cm<sup>2</sup>) operation.

- Nuclear applications.
- Missiles.
- Artillery applications (high spin).
- **Volumetric energy density of high spin thermal batteries has been increased by a factor of 8 since FY96 at ARL.**



2. High reliability and mature technology could be applied to low-current operation.



# Low-Current Thermal Battery Goals



- **Small size.** 0.1 cm<sup>3</sup> – (0.2 in. dia. x 0.2 in. tall)  
0.8 cm<sup>3</sup> – (0.4 in. dia. x 0.4 in. tall)
- **Low current.** (50 mA to 20 mA, 3 to 10 V)
- **Moderate lifetime.** (5 to 10 minutes)
- **High reliability.** (0.9990 at 95% confidence)
- **Long shelf life.** (20 years)



# Miniaturization Method

1. Heat transfer is a major problem.
  - High temperature molten salt electrochemistry.
  - Control heat loss rates.
  - Control cell heat generation rates.
2. Optimize a low-current battery design.
  - Calculate thermal lifetime.
  - Operating cell temp. range is 325 to 700° C.
  - Ambient temp. range is -43 to +63° C.
  - 4 thermal cells (7.2 V to 5.4 V at 1.5 mA).

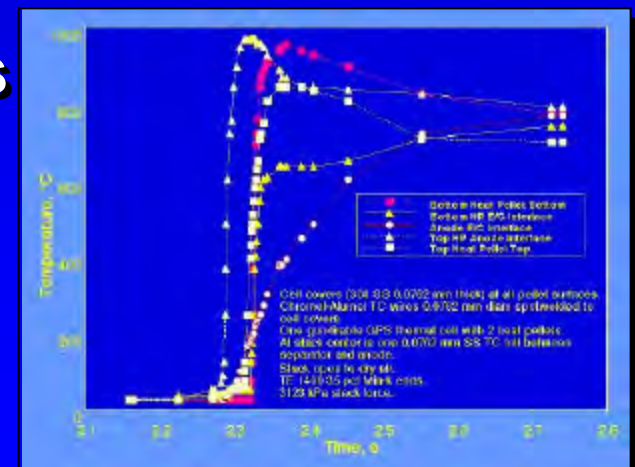



# Heat Transfer Considerations



**1. Thermal conductivities could be reduced by a factor of 8 in production thermal batteries.**

- Improved commercial insulators.
- Improved chemical processing.
- Use of gas gettering agents.

**2. Construction improvements facilitate miniaturization.**

- Single pellet thermal batteries.
- Control of heat generation.
- New electrochemical systems.





# Present Miniaturized Thermal Battery

- Volume 9.38 cm<sup>3</sup>.
  - case is 0.90 inch diameter x 0.90 inch long
  - thermal cell diameter is
- Energy density at 1.5 mA drain 0.090 Wh/l.
  - **320 s thermal lifetime**
- Present battery pellets, gas environment, chemical exothermic reactions.
- Cells contain 72.0 times required electrochemical capacity at 1.5 mA drain.

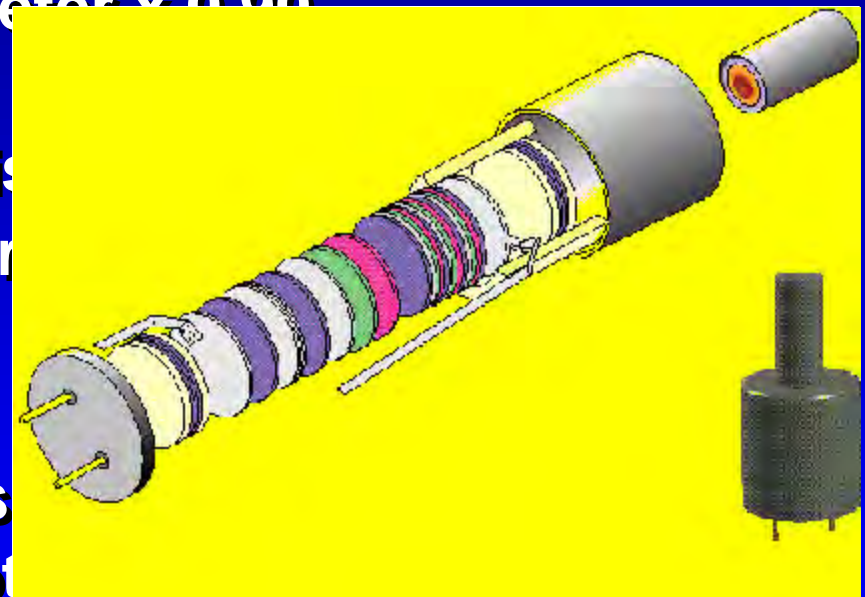



# Miniaturized Thermal Battery (2 to 5 Years)

- Volume 0.552 cm<sup>3</sup>.
  - case is 0.35 inch diameter x 0.35 inch long
  - thermal cell diameter is 0.2 inch
- Energy density 1.61 Wh/l at 1.5 mA drain.
  - **338 s thermal lifetime**
- Multi-pellet construction, improved gas environment from improved chemical processing, some gas gettering.
- Cells contain 3.41 times required electrochemical capacity at 1.5 mA drain.



# Miniaturized Thermal Battery (5 to 10 Years)

- Volume 0.129 cm<sup>3</sup>.
  - case is 0.20 inch diameter x 0.25 inch long
  - thermal cell diameter is 0.12 inch
- Energy density 11.5 Wh/l at 1.5 mA drain.
  - **566 s thermal lifetime**
- Single pellet battery construction, improved chemical processing and gas gettering, along with increased internal heat generation.
- Cells contain 1.10 times required electrochemical capacity at 1.5 mA drain.



# Energy and Power Densities

	Present Thermal	Thermal 2 to 5 Years	Thermal 5 to 10 Years	Present SDF Battery
Wh/l	0.090	1.61	11.5	0.744
Wh/kg	0.061	0.738	4.19	0.159
W/l	1.01	17.1	73.4	9.92
W/kg	0.685	7.85	26.6	2.11
cm <sup>3</sup>	9.38	0.552	0.129	0.128

Thermals operate at 7.2 to 5.4 V and 1.5 mA.



# Lifetime and Pulse Characteristics

	Present Thermal	Thermal 2 to 5 Years	Thermal 5 to 10 Years	Present SDF Battery
Life (s)	320	338	566	270
Pulse (kW/l)	2.10	8.97	13.8	0.027
Over-design (Ratio)	72.0	3.41	1.10	

Thermals operate at 7.2 to 5.4 V and 1.5 mA.



# Thermal Battery Starters Require Miniaturization

1. Inertial White starter is 0.312 inch diameter x 1.05 inch long (**1.32 cm<sup>3</sup>** and 6.5 g).
2. Inertial M42 C-1 primer is 0.175 inch diameter x 0.120 inch long (**0.0473 cm<sup>3</sup>** and 0.20 g).
3. Inertial M42 C-1 primer starter is similar in size and mass to the White starter. **One primer starter might be used for several inertial primers.**
4. Electrical squib is 0.205 inch diameter x 0.185 inch long (**0.100 cm<sup>3</sup>** and 0.56 g).





# Conclusions

- 1. Small thermal batteries can be made the size of present thermal battery squib initiators.**
- 2. Thermal batteries the size of present squib initiators can operate for several minutes at  $\mu\text{A}$  and  $\text{mA}$  current drains.**
- 3. Low-current thermal batteries can be used in miniaturized fuzes where they can supply large pulse currents.**



# The Evolving Fuze or When a Fuze is not just a Fuze

Colonel Richard Hulmes  
AD Land Manoeuvre Division  
UK Defence Ordnance Safety Group



# DELIVERING FUZE SAFETY

## NATO SAFETY STANDARDS

### AC310 Sub Group 2

### FUZES



# *SAFETY*

## *THE GENERAL BUSINESS*

### *CASE*

- 💣 OBVIOUS - ENVIRONMENTAL AND PUBLIC PRESSURE
- 💣 POLITICAL WILL (eg LANDMINES)
- 💣 LEGISLATION - UK HSWA 1974 s6(1)
- 💣 LITIGATION



# *SAFETY*

## *THE DEFENCE BUSINESS*

### *CASE*

- 💣 CONFIDENCE IN EQUIPMENT
- 💣 PROTECT OUR SERVICE PERSONNEL
- 💣 STANDARD SAFETY TESTING
- 💣 INTERNATIONAL COMPATIBILITY
- 💣 OFF THE SHELF PROCUREMENT



# NATO International Safety Standards

## STANAG 4187

Fuzing Systems - Safety Design Requirements

## AOP 16

Fuzing Systems - Guidelines for STANAG 4187

## AOP 42

Integrated Design Analysis for Munition Initiation Systems and other Safety Critical Systems



# Definitions

## Fuzing System (STANAG 4187)

A system designed to:

- ❗ Provide as a primary role safety and arming functions in order to preclude munition arming before the desired position and time
- ❗ Sense a target or respond to one or more prescribed conditions, such as elapsed time, pressure or command
- ❗ Initiate an explosive train in a munition



# FUNDAMENTAL SAFETY DESIGN REQUIREMENTS - STANAG 4187

9.1.1 Fuzing systems shall include at least two safety features, the operation of which are, wherever possible, functionally isolated from other processes within the munition system ...



# Processes which may use but are not considered part of Fuzing systems in normal operation

- 💣 Course Correction
- 💣 Flight Termination\*
- 💣 Remote Control (sensor)
- 💣 Anti - Dud
  - 💣 (Unexploded Munition = Landmine)
- 💣 Demilitarisation/Disposal\*
- 💣 ?

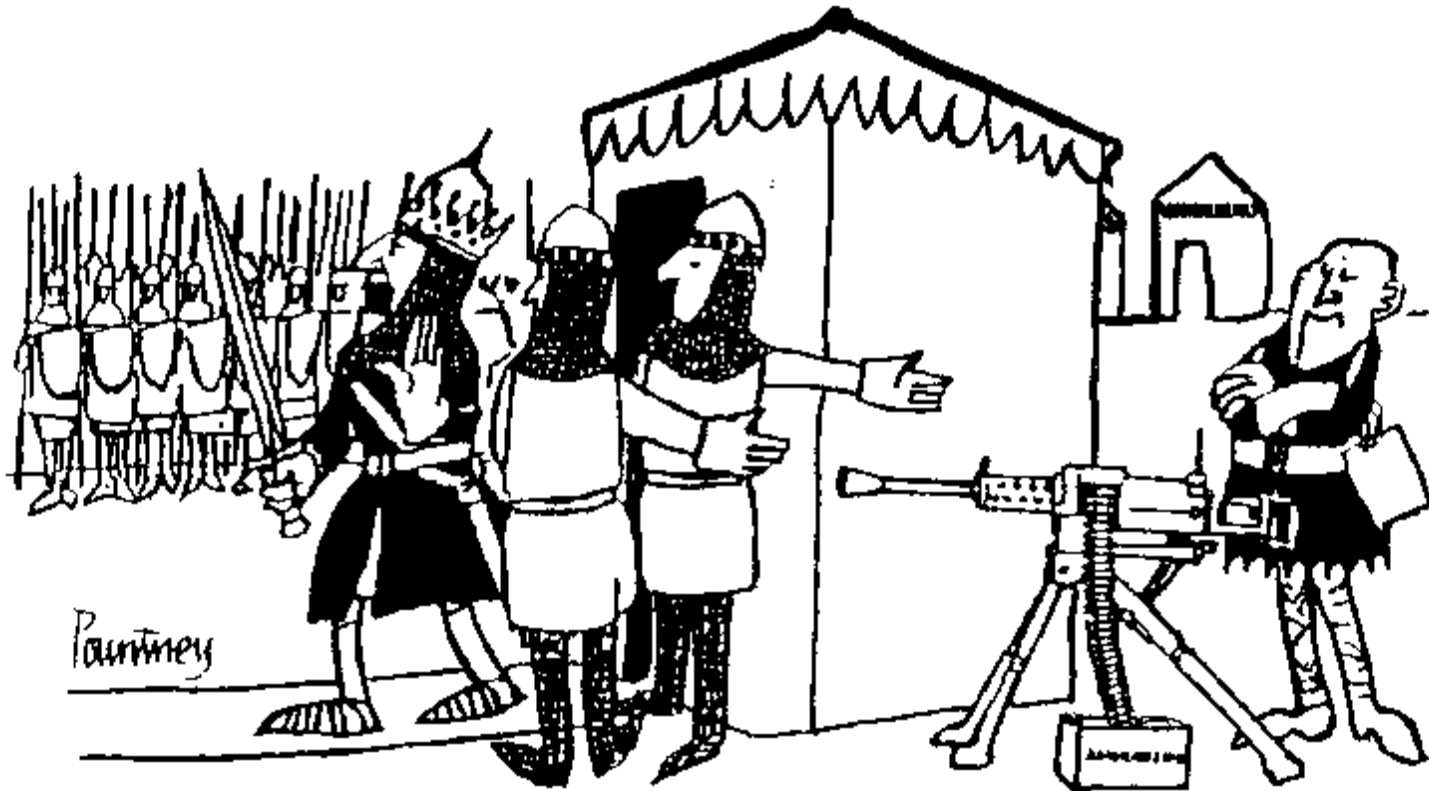

**Tell him that unless it complies with STANAG 4187  
I don't care how good it is!**



# Some Principles

- 💣 Must not compromise intrinsic safety
- 💣 Add-ons should be independent
- 💣 Novel solutions considered - supported by Design Analysis
- 💣 Use STANAG 4187, AOP 16 & 42
  - ➔ National Safety Approving Authority



# Concept Approval - Recommendations

- 💣 Hazard Analysis
- 💣 Fault Tree Analysis
- 💣 Design Logic
- 💣 Integrated Design Analysis (AOP 42)



Colonel Richard Hulmes

➤ [dosglm-ad@dpa.mod.uk](mailto:dosglm-ad@dpa.mod.uk)

Major David Parrott

➤ [dosglm3a@dpa.mod.uk](mailto:dosglm3a@dpa.mod.uk)



# Any Questions?

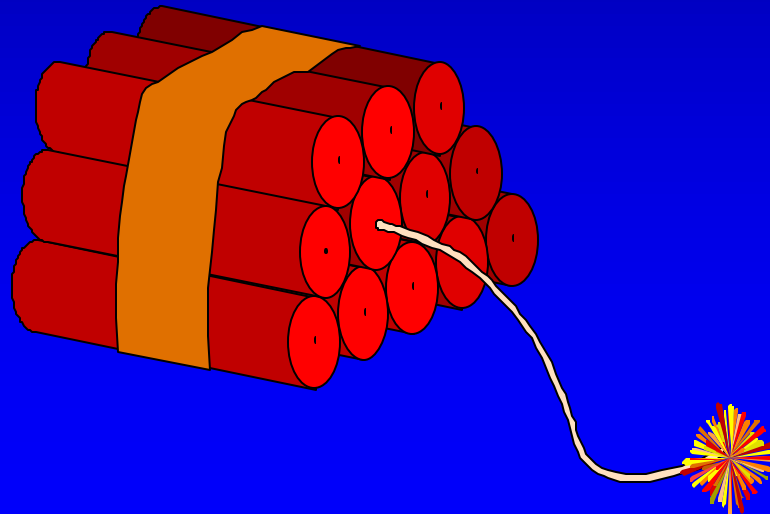



# FMU-160B: 105mm PROXIMITY FUZE FOR THE AC130



*45th Annual Fuze Conference*



Bob Hertlein, Dave Lawson  
KDI Precision Products, Inc.

Telly Manolatos  
Electronics Development Corp

**KDI Precision Products, Inc.**  
An ISO 9001 Registered Company

<http://www.kdi-ppi.com>



# Presentation Outline



- **Application**
- **Need for Improved Proximity Fuze**
- **Design Goals**
- **Design Approach**
  - ✧ **RF Front End**
  - ✧ **Signal Processor**
  - ✧ **Battery**
  - ✧ **S&A**



# Application



## ➤ AC-130 Gunship

- ✧ Air Force Special Operations Command (AFSOC)
- ✧ Modified M137 105mm Cannon





# Need for Improved Proximity Fuze



- **High Fragmentation (HF) Version of HE M1 (MOD) Cartridge**
  - ✧ **Maximum effectiveness requires precise HOB regardless of target reflectivity and approach angle**
  - ✧ **Proximity fuzes currently available are not optimized for the HF round**
    - ◆ **Wide HOB variation**
    - ◆ **Average HOB not optimum**
    - ◆ **Insufficient reliability**



# Design Goals



- **Tight HOB Control**
  - ✧ **Nominal HOB = 15 ft**
- **Impact Back-up Mode**
- **Highly Reliable**
- **Surface Mount Technology**
- **Maximum Commonality to Existing Designs**
  - ✧ **Proven Reliability**
  - ✧ **Reduced Cost**



# Design Approach

- **RF Front End**
- **Signal Processor**
- **S&A**
- **Battery**



# RF Front End



- **Based on Highly Successful M734A1 Multi-Option Fuze for Mortars (MOFM)**
  - ✧ **MMIC Transceiver**
  - ✧ **Circular Patch Antenna**
    - ◆ **Wide Bandwidth**
    - ◆ **Broad Coverage**
  - ✧ **Additional IF Gain Stage**



# Signal Processor



- **Same Signal Processor as the M734A1 MOFM**
- **Utilizes DDR Technology**
  - ✧ **Accurate HOB Control**
  - ✧ **Robust Anti-jamming Performance**
- **Highly Integrated**
  - ✧ **Single Chip Solution**
  - ✧ **High Reliability**
  - ✧ **Low Cost**



# TYPICAL PERFORMANCE



M734A1 - 120mm Prox Mode, Charge 0, -40°F, 1500 QE  
HOB Histogram

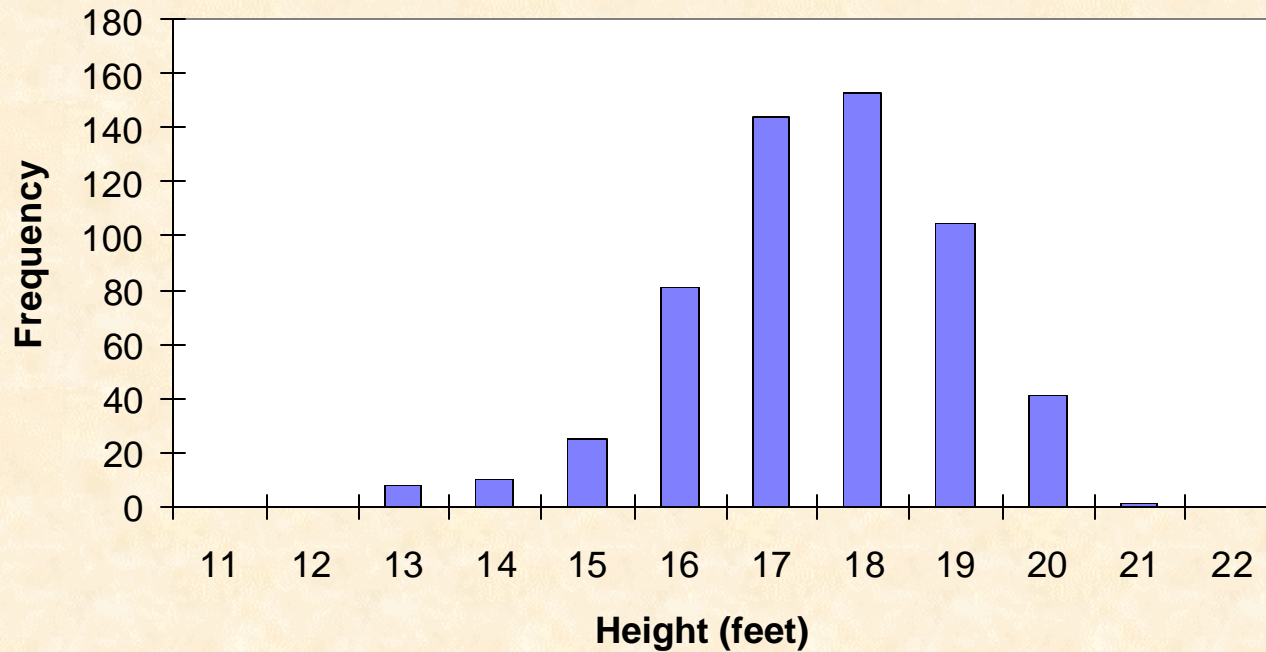



**S&A**



- **MK41 is a Qualified Design**
- **Low Cost**
- **Performance Parameters:**
  - ✧ **Setback g Level: 26,000 g**
  - ✧ **Spin Rate: 410 rps**
  - ✧ **Velocity: 3075 ft/sec**



# Battery



- **Manufactured the Netherlands by Thales Munitronics**
  - ✧ **Formerly Signaal USFA**
- **Chemistry: Lithium**
- **Proven Design for Artillery**
- **Performance Parameters:**
  - ✧ **Operational Life: 150 seconds min**
  - ✧ **Current: 150 mA**
  - ✧ **End of Life Voltage: 5.5 Volts min**
  - ✧ **Rise Time: 100 mSec max**
  - ✧ **Required Setback: 2000 g's min**
  - ✧ **Required Spin: 2500 rpm min**
  - ✧ **Operating Temperature: -40F to +145F**



# Photo of FMU-160/B





# Summary

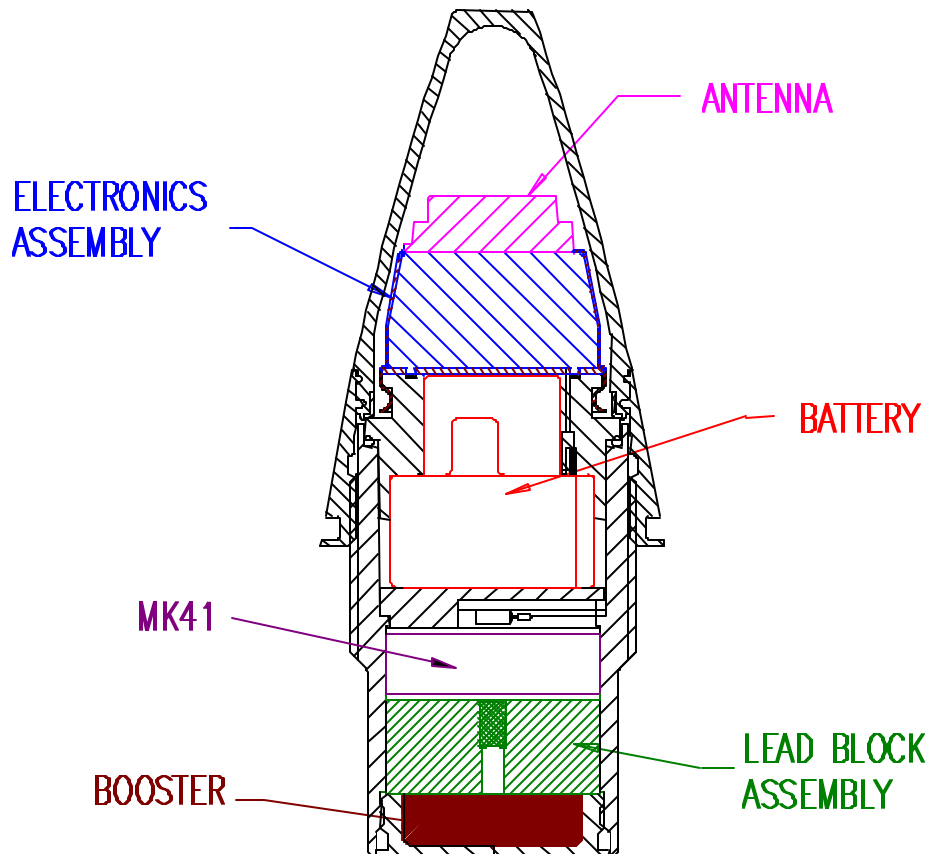

➤ **ACCURATE**

➤ **RELIABLE**

➤ **AFFORDABLE**



# KDI Precision Products, Inc.

An ISO 9001 Registered Company

## Common Precision Munitions Safety & Arming Device

**45th Annual Fuze Conference**

"The Evolving Nature of Value Added Fuzing"



Presented By: Mr. Richard Dirks

[www.kdi-ppi.com](http://www.kdi-ppi.com)



# OUTLINE

- ERGM System Overview
- ERGM Payload Sequence
- XM982 System Overview
- XM982 Payload Sequence
- ERGM S&A Location
- XM982 S&A Location
- S&A Technical Requirements
- MIL-STD-1316D Compliance
- S&A Mechanical Design
- S&A Electrical Design
- S&A Integration
- S&A Event Sequence, Outputs, and Capabilities
- Program Test Results / Milestones



# EX171 ERGM OPERATIONAL CONCEPT

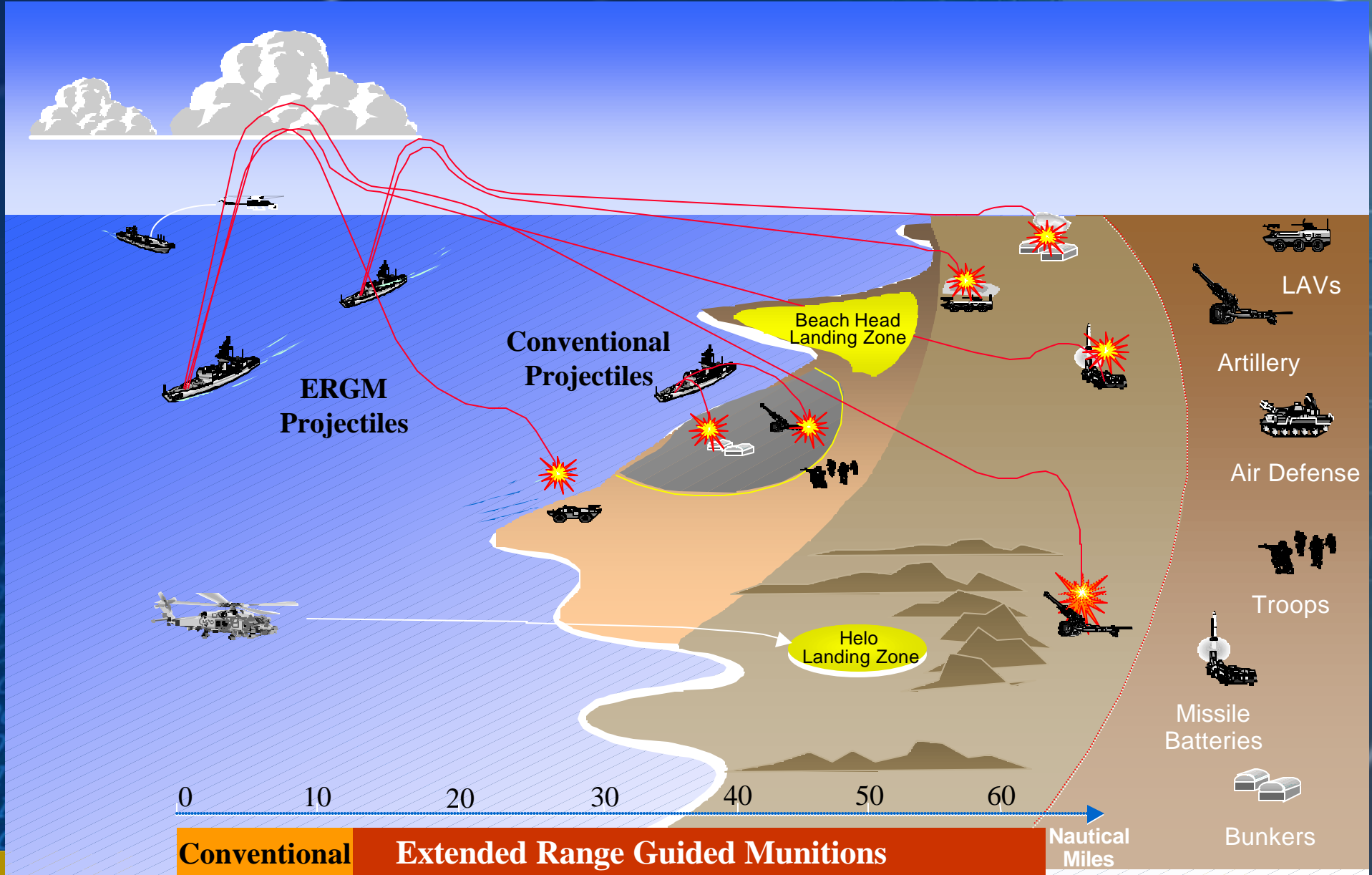

# ERGM SUBMUNITION EXPEL & DISPENSE

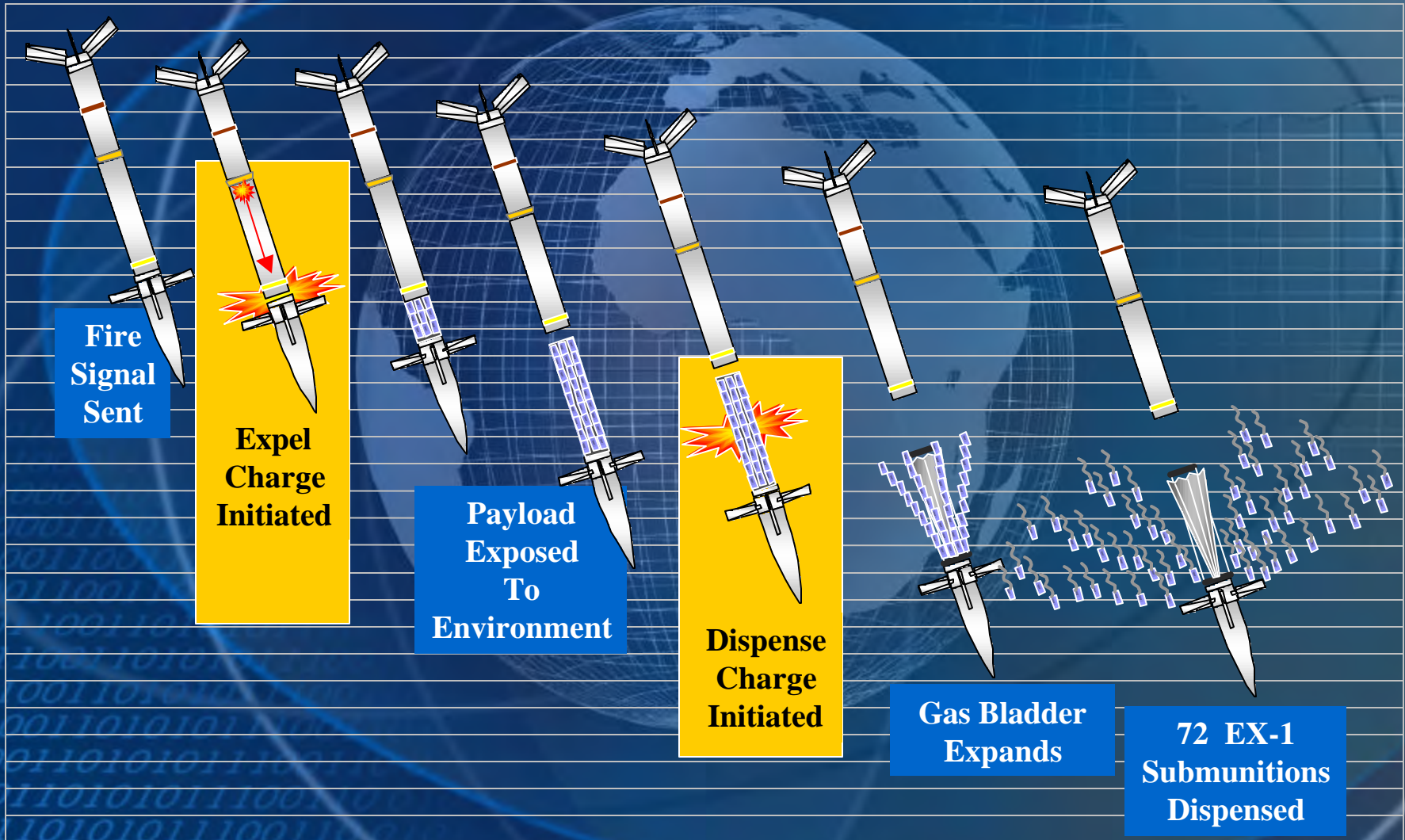

# EXCALIBUR OPERATIONAL CONCEPT

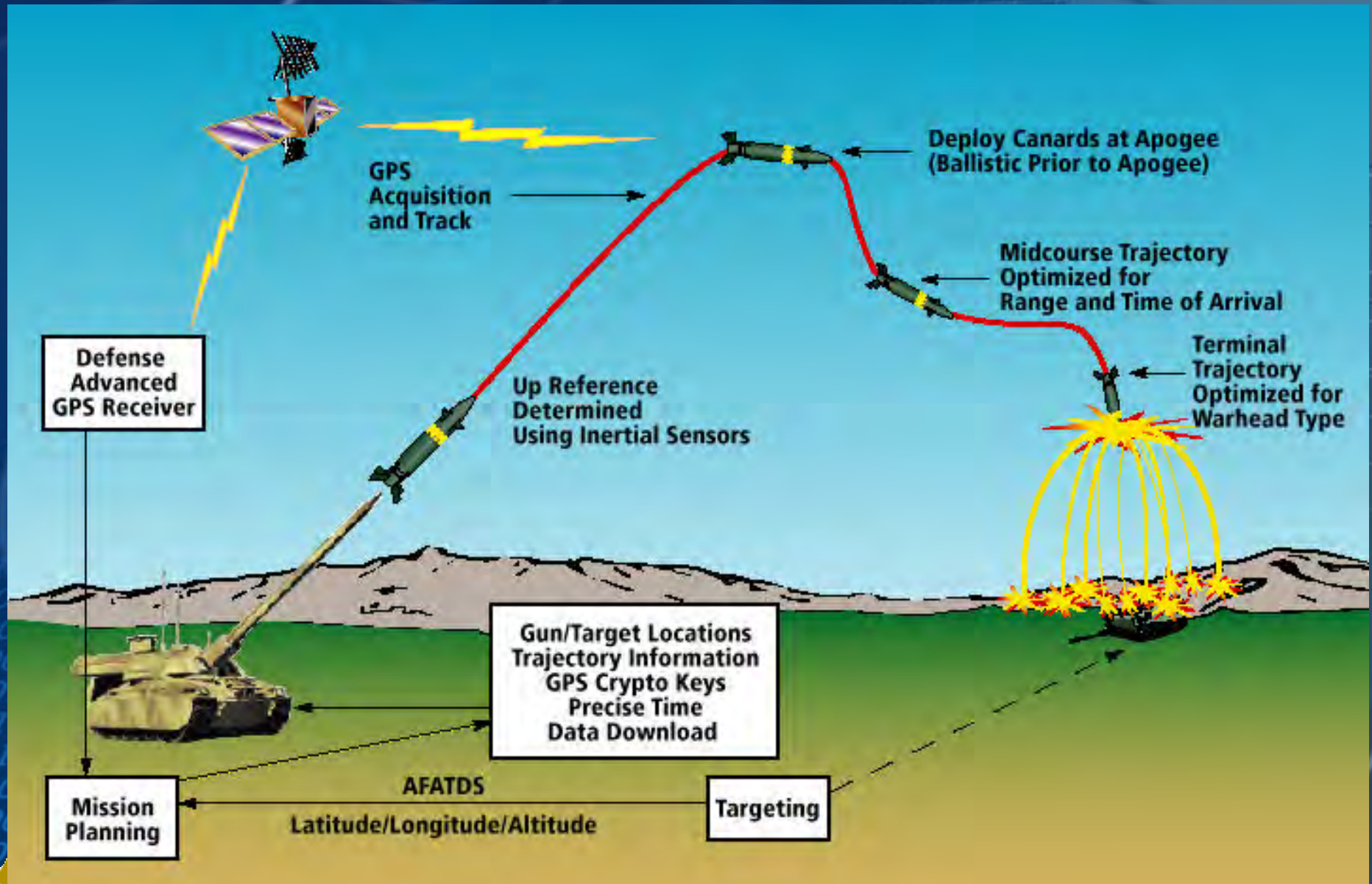

# EXCALIBUR SUBMUNITION EXPEL & DISPENSE

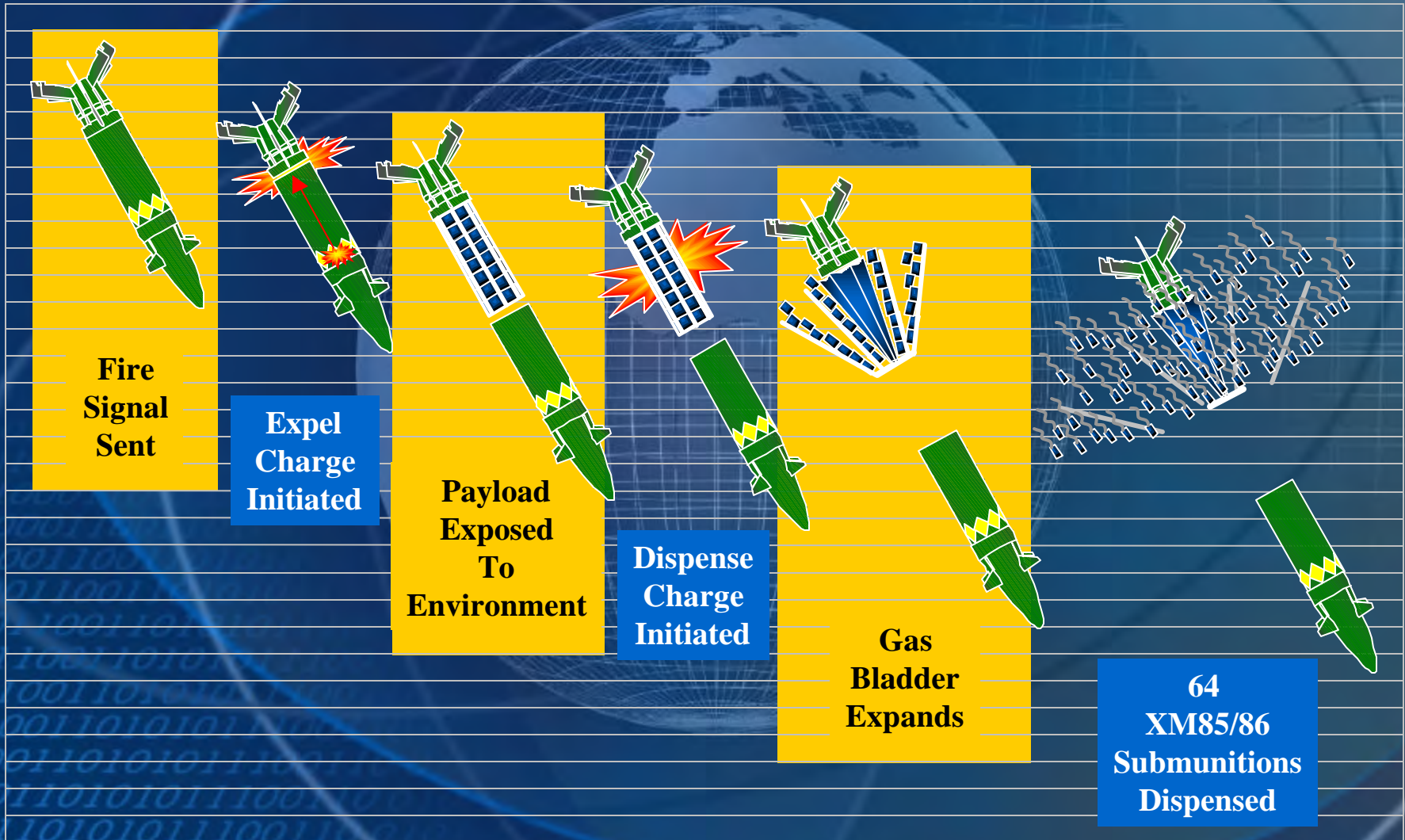

# ERGM EX87 S&A DEVICE AND LOCATION

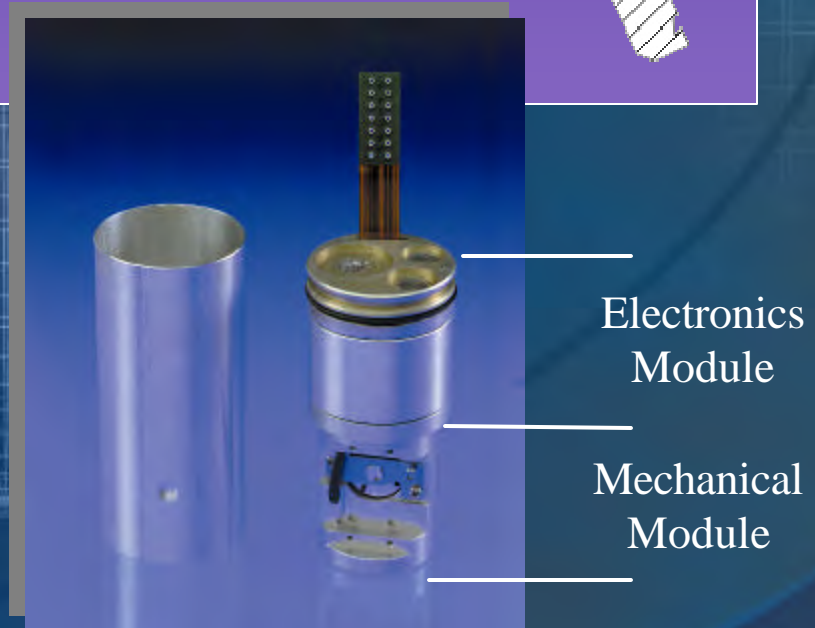
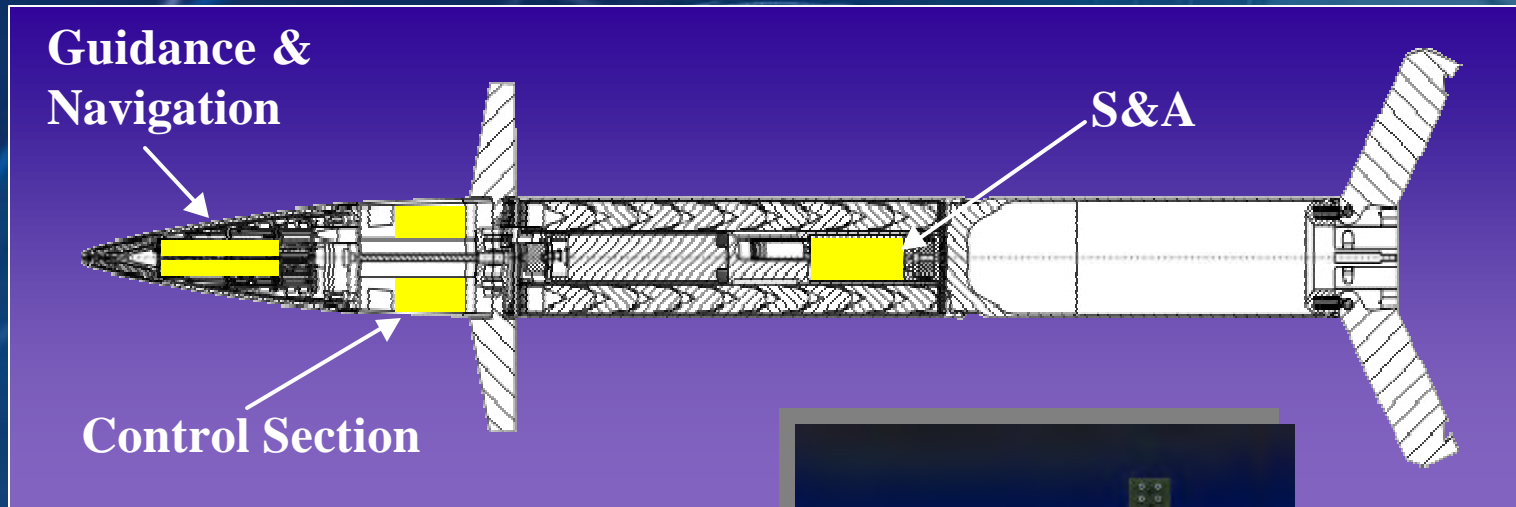

# XM982 S&A DEVICE AND LOCATION

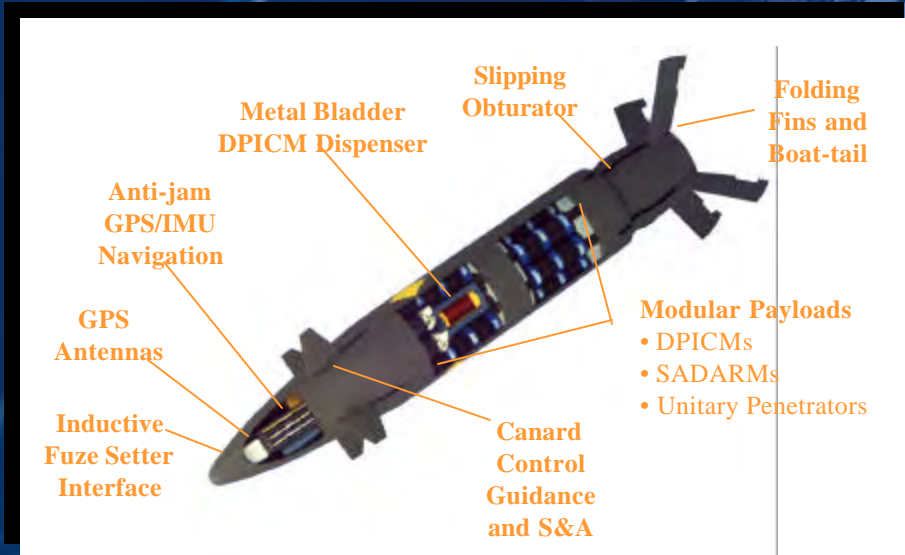

# S&A REQUIREMENTS

- Projectile Application
  - All Arm - 1,250 G's
  - No Arm - 300 G's
- No Spin
- Interface With GN&C
- MIL-STD-1316D Compliant
- Seal Against “Expel” Pressure
- ERGM Unique
  - Support “Dispense” Forces
  - User Selectable Output
  - Autonomous “End Game” Operation



# MIL-STD-1316D COMPLIANT

## ERGM/XM982

- Two Independent Locks
- Enhanced Overhead Safety
- Set Back
- Anti-Malassembly Feature
- GN&C
- Launch Derived Rotor Drive Energy
- Sequence Dependent
- Selectable Output (ERGM Only)

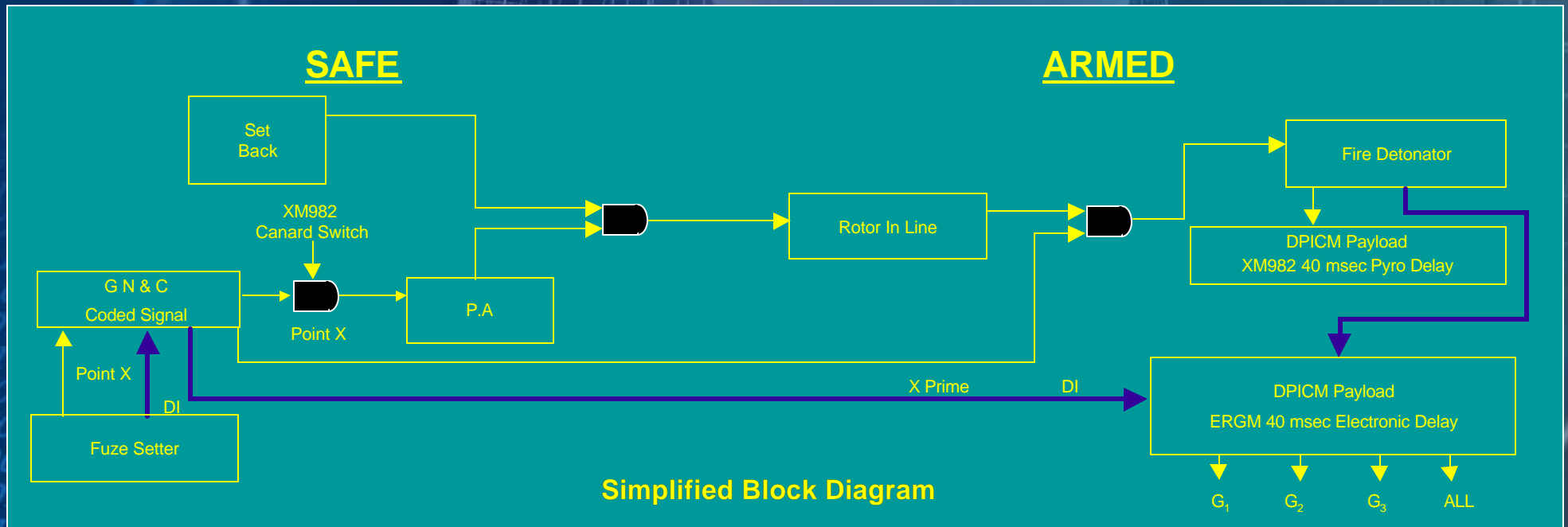

# S&A MECHANICAL DESIGN APPROACH

- Mechanical S&A Design Approach
  - Modified MK18 S&A
    - Higher G Loads
    - AFT Detonation Output
    - Switches Indicate Rotor Position
    - Integrated Electronics Control
  - Three (3) Leaf Set Back Mechanism

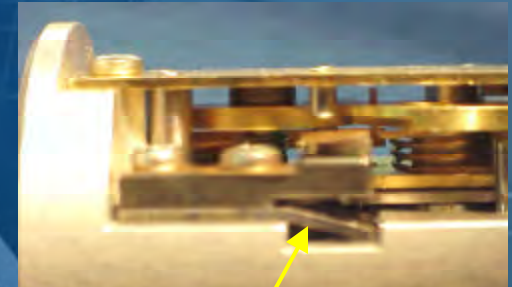

Second Rotor Lock (Safe)

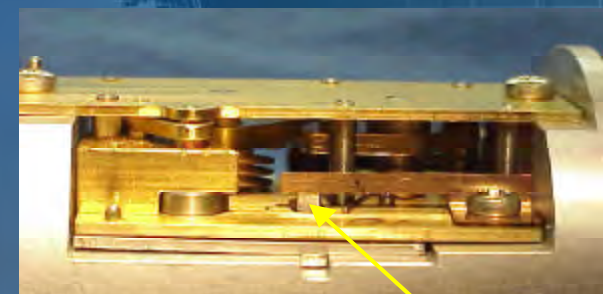

Rotor Lock (Arm)

Leaf Lock

Rotor Drive Spring

First Rotor Lock (Safe)

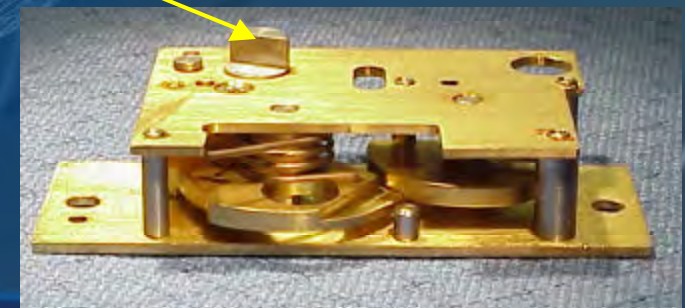
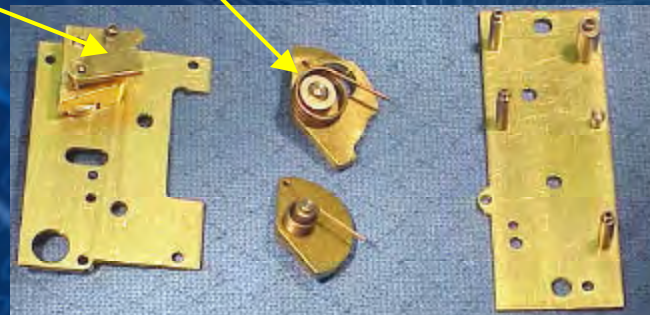

# S&A ELECTRICAL DESIGN APPROACH

- S&A Electronics
  - RS232 Serial Communication Link
  - Codeword Controls Function

GN&C  
Second Rotor Lock W/PA

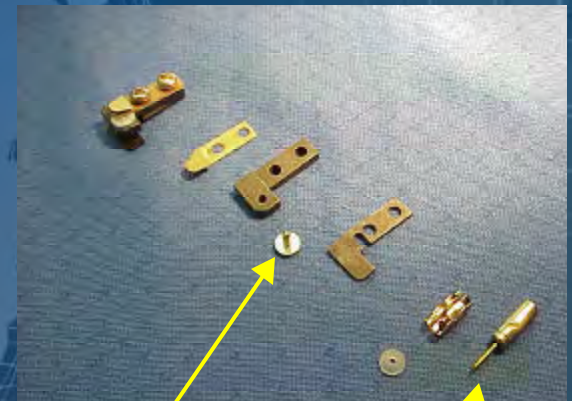

Safety Button

Piston Actuator

Second Safety & Arm Lock



Set Back Lock

Rotor W/Switches & M84 Detonator



# ELECTRONICS PACKAGE

- Electronics Design
  - Flexible PWB
  - SMT
  - Glass Bead Fill
  - Mosfet Circuitry
    - Independent Timer (10 sec)
    - FPGA
  - Energy Storage
    - Autonomous Operation
    - Two Stage Timed Function

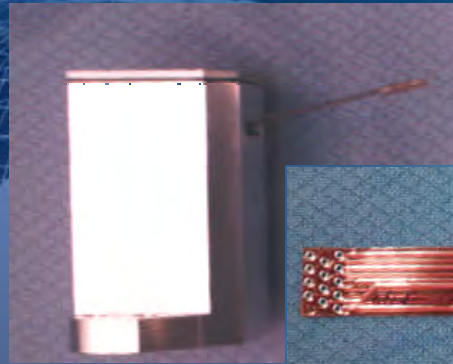

XM982

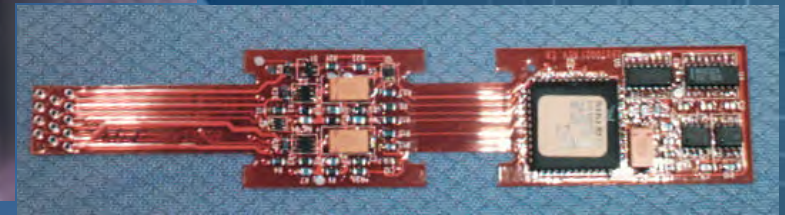

ERGM



# S&A OUTPUTS

- Energetic
  - M84 Electric Detonator Initiates Expel Charge
    - Solder Sealed Enclosure
    - Platinum Bridgewire
- ERGM Dispense Module
  - Initiate Cartridge Primers (44 magnum, 45-70, and 10 gauge)
- XM982 Dispense Module
  - Pyrotechnic Delay

XM982

ERGM

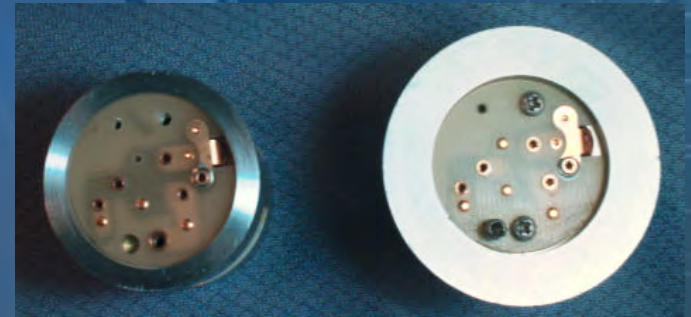

ERGM



# S&A INTEGRATION

XM982 S&A

- Centrally Located
  - Seal Against Pressure
  - Support Structural Load
  - S&A weight Less Than 1 Lb. (Less Expel Liner)
  - Integral Cabling To GN&C

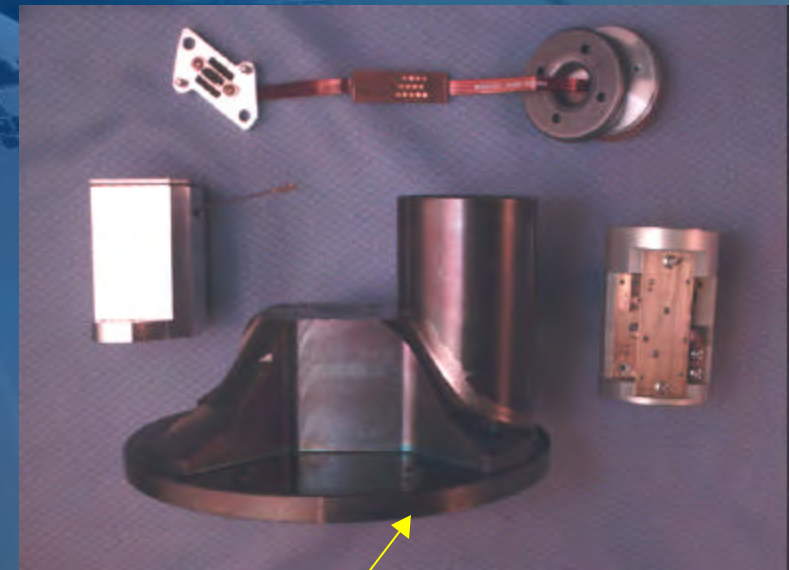

Expel Liner



ERGM EX 87 S&A



# S&A DESIGN SUMMARY

- Resulting Capabilities
  - Meets MIL-STD-1316D
  - Interactive W/ GN&C
  - Maximized Overhead Safety
    - Independent Timer
    - Arm Command issued Just Prior to Endgame
  - Variable Outputs ERGM Only



ERGM



XM982



# S&A PROGRAM MILESTONES

- ERGM EX 87 S&A
  - Piston Actuator Qualification - May & June '01
  - EX87 S&A Qualification - July thru September '01
- XM982 S&A
  - Completed Design Analysis Phase, Ready for Verification Testing
  - At present - On Hold



**Microwave Fuze**

**INNOVATIVE DIGITAL PROXIMITY FUZE  
FOR 76/62 mm GUN  
(Microwave, Programmable)**



 Odobreda Division

 **Alenia**  
DIFESA

*Companies*



**SIMMEL DIFESA**

*Marco BROGI  
Maurizio CALEO*

*Authors*

*Antonio CARRIERO*

45th Fuze Conference, Long Beach, CA, April 16-18 2001

**Microwave Fuze**

# ITALIAN NAVY

awarded the development contract

**ALENIA DIFESA**

**OTOBREDA DIV.**

(former OTO Melara)

- computer modeling
- $\mu$ W sensor
- signal processor
- firing tests

**SIMMEL DIFESA SpA**

(heritage from Borletti and BPD)

- fuze integration
- impact sensor
- post-impact delay
- battery
- S&A
- pyrotechnic chain

 OtoBreda Division

 **Alenia**  
DIFESA



**SIMMELDIFESA**

## *Microwave Fuze*

# FUZE MAJOR FEATURES

- PROGRAMMABILITY OF OPERATING MODES  
from the FCS through a setter
- 5 OPERATING MODES
  - PROXIMITY vs SEA SKIMMER (default mode)
  - PROXIMITY vs FIXED WING AIRCRAFT
  - PROXIMITY vs ROTARY WING AIRCRAFT
  - PROXIMITY vs SURFACE TARGETS
  - DELAYED IMPACT vs REINFORCED TARGETS
- 2 BACK-UP MODES (not available if delayed impact is selected)
  - UNDELAYED IMPACT
  - SELF DESTRUCTION



**SIMMEL DIFESA**

## FUZE MAJOR FEATURES continued

- SAFETY SYSTEM
  - COMPLIANT WITH STANAG 4187
  - SAFE SEPARATION DISTANCE (MECHANICAL ARMING) > 100 m
- OPERATING TEMPERATURE RANGE  $-31^{\circ}\text{C} \div +63^{\circ}\text{C}$
- STORAGE TEMPERATURE RANGE  $-40^{\circ}\text{C} \div +71^{\circ}\text{C}$

## Microwave Fuze

# ELECTRONIC SETTING SYSTEM FOR 76 mm PROXIMITY FUZE

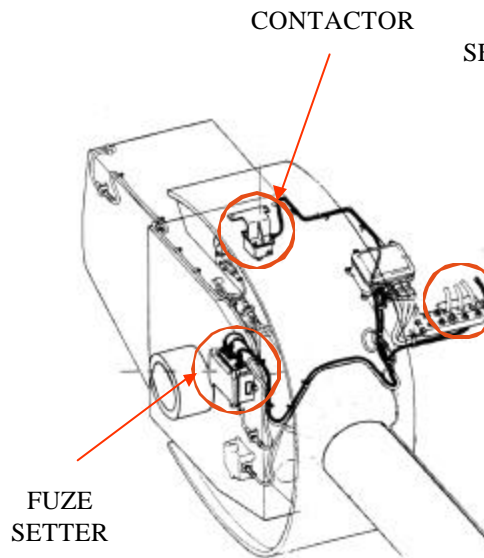

**INSTALLATION ON GUN ELEVATING MASS**

## FUNCTIONAL BLOCK DIAGRAM

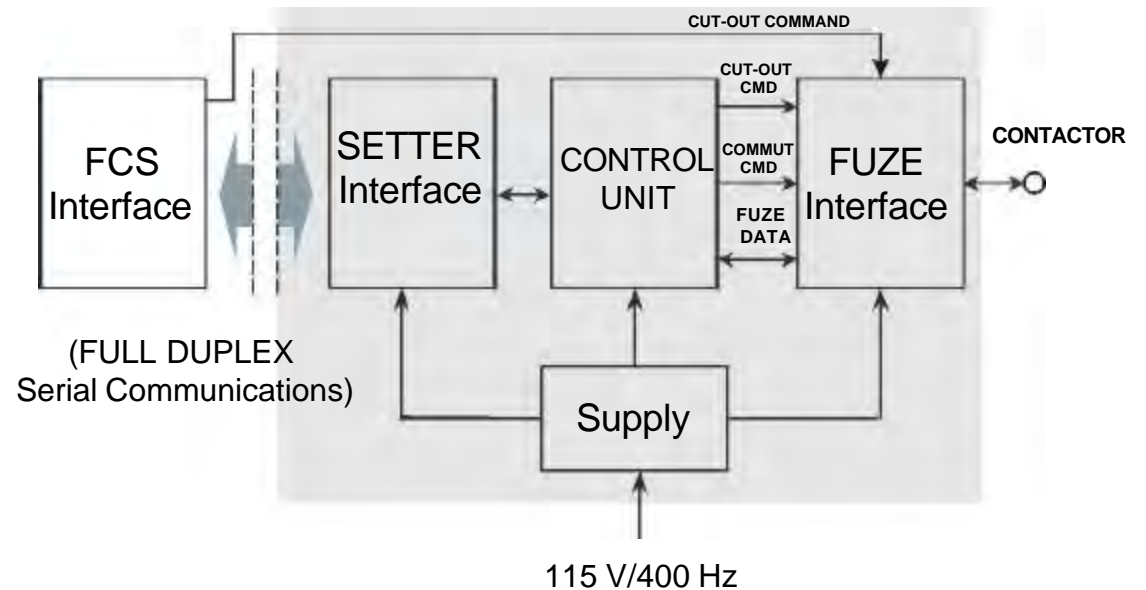

*Microwave Fuze*

## ELECTRONIC SETTER FOR 76 mm PROXIMITY FUZE



- DEVELOPMENT COMPLETED
- 4 SYSTEMS ORDERED BY ITALIAN NAVY FOR NEW FPB's
- 18 SYSTEMS WILL BE INSTALLED ON EXISTING SHIPS

 Odobreda Division

 **Alenia**  
DIFESA



**SIMMEL**DIFESA

*Microwave Fuze*

## **ELECTRONIC SETTER FOR 76 mm PROXIMITY FUZE**

### **FUNCTIONS**

- **SELECT THE OPERATING MODE (PROXIMITY/DELAYED IMPACT).**
- **ENABLE FUZE RECEIVER JUST BEFORE TARGET INTERCEPT.**
- **OPTIMIZE PROXIMITY PERFORMANCE AGAINST DIFFERENT KINDS OF TARGETS BY SELECTING DEDICATED SOFTWARE.**
- **RETAIN THE COMPATIBILITY WITH IN-SERVICE FUZES**

 **Odobreda Division**

 **Alenia**  
DIFESA



**SIMMEL DIFESA**

## Microwave Fuze

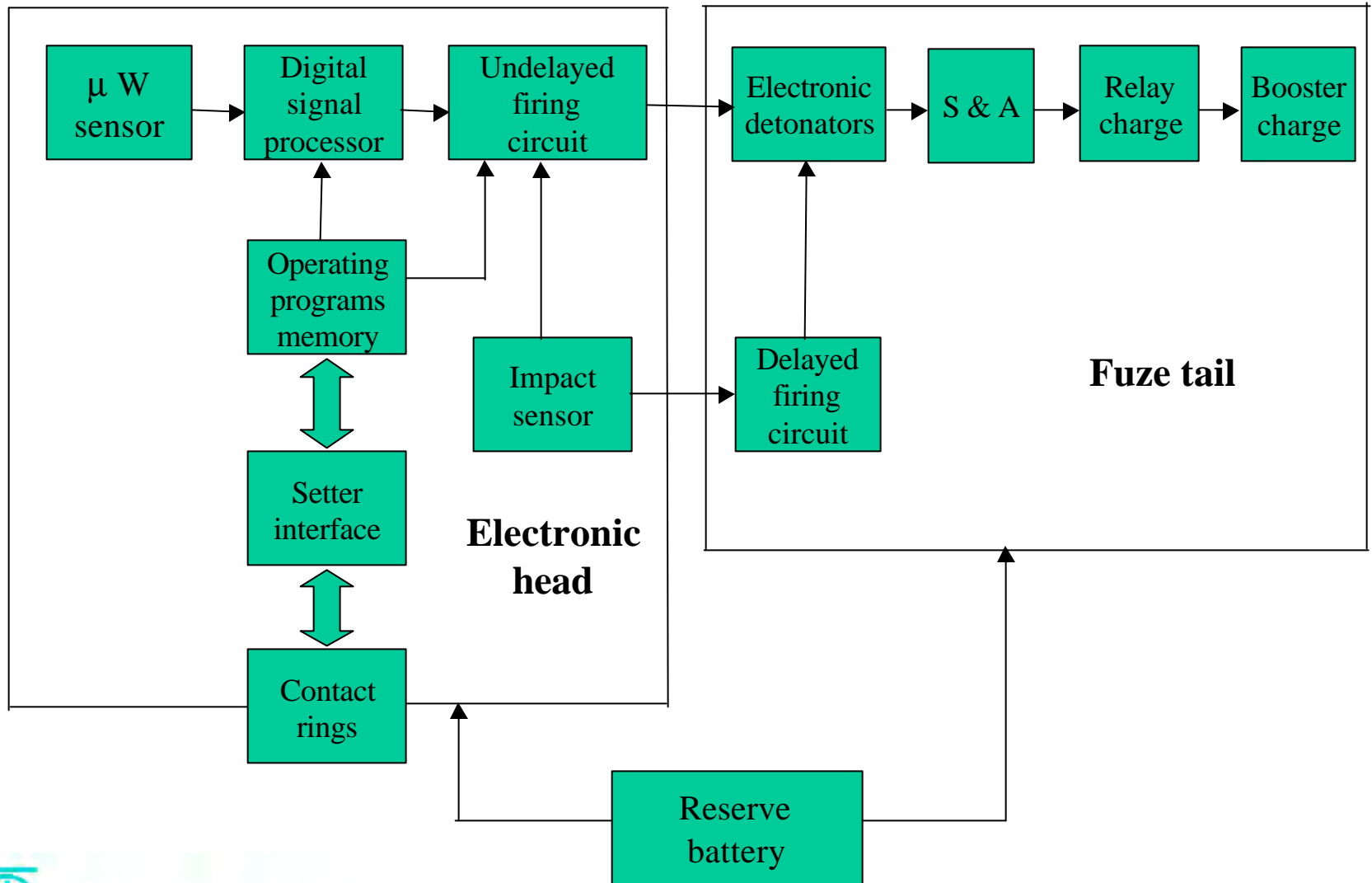

**Microwave Fuze**

# Fuze layout

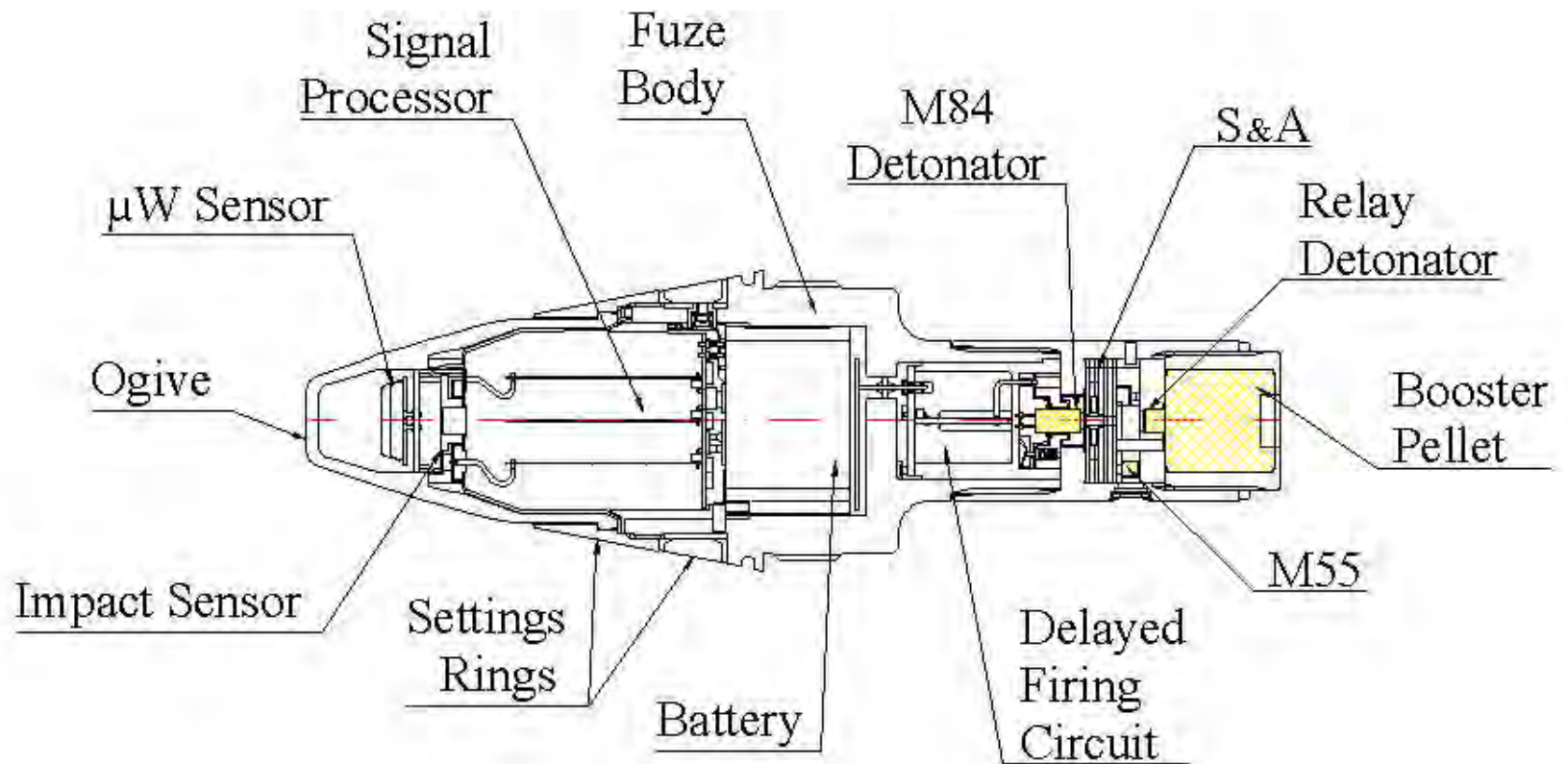

*Microwave Fuze*



**Microwave Fuze**

# FUZE TECHNICAL DESCRIPTION

## ELECTRONIC HEAD BREAKDOWN

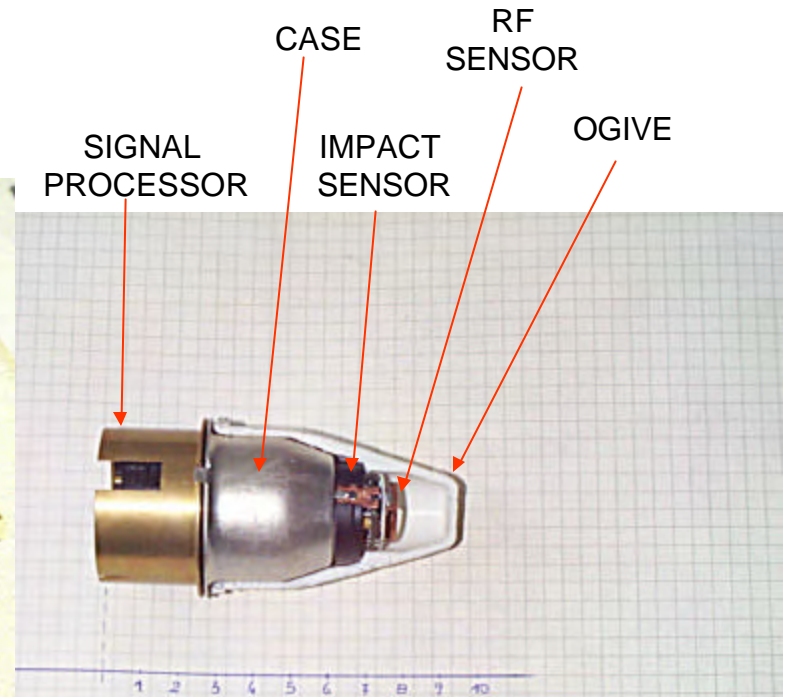
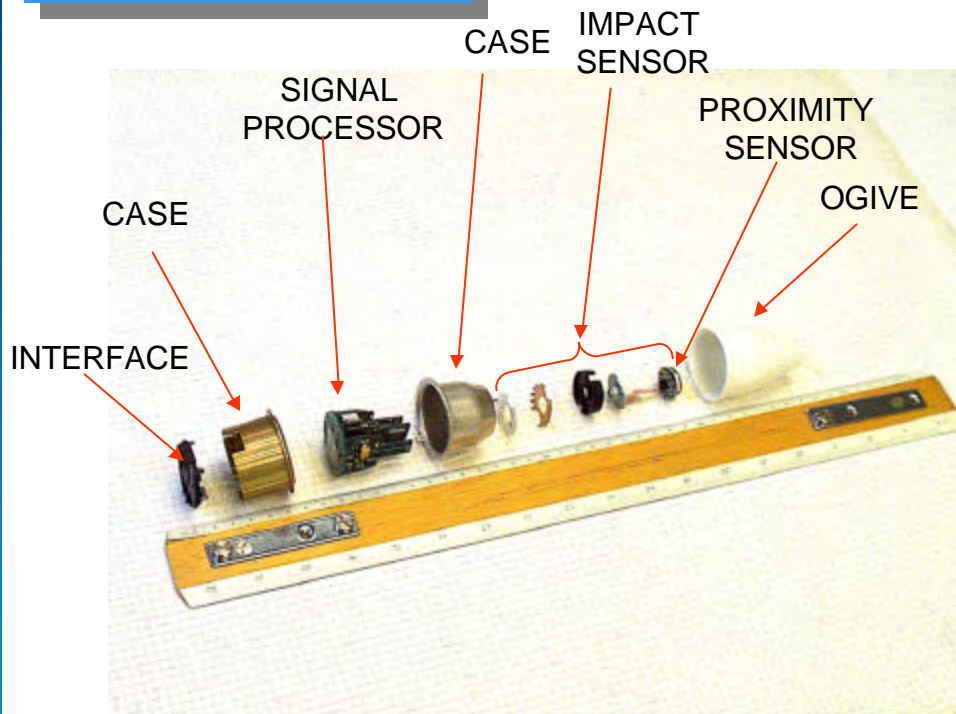

## ELECTRONIC HEAD ASSEMBLY

**Microwave Fuze**

## TELEMETRY PROJECTILE FOR IN FLIGHT TEST

USED DURING FUZE DEVELOPMENT



FUZE UNDER TEST

TELEMETRY  
EQUIPMENT

- 2 A.C. CHANNELS FOR SENSORS SIGNALS (WIDEBAND)
- 2 D. C. CHANNELS FOR POWER SUPPLY CHECK
- 1 TRIGGER CHANNEL FOR DETONATION CHECK

TELEMETRY  
ANTENNA

Otobreda Division

**Alenia**  
DIFESA



**SIMMEL**DIFESA

## Microwave Fuze

# WHY A NEW FUZE

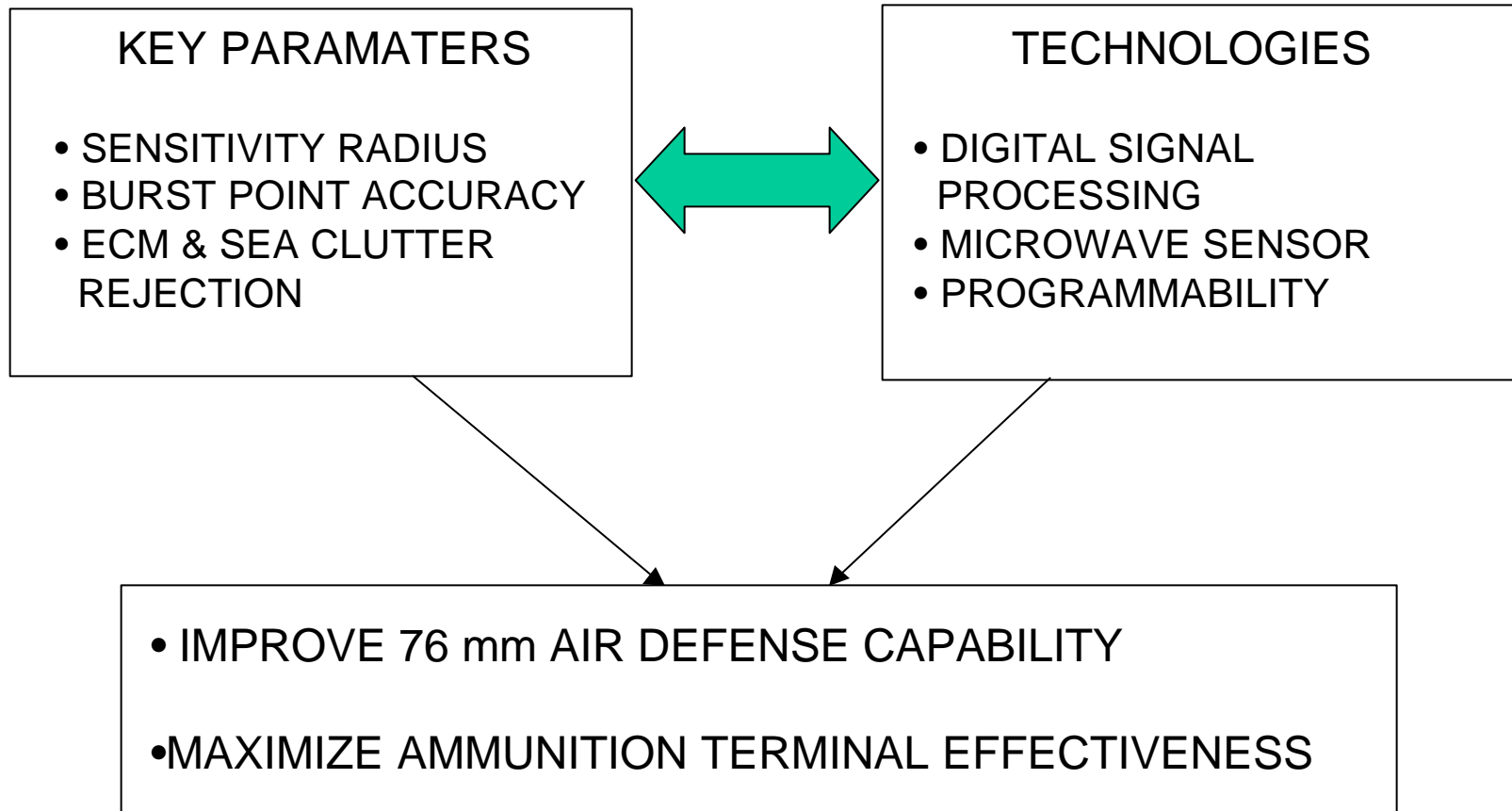

# CHARACTERISTICS OF THE NEW MICROWAVE FUZE

USEFUL BURST ZONE FOR AMMUNITION TERMINAL EFFECTIVENESS

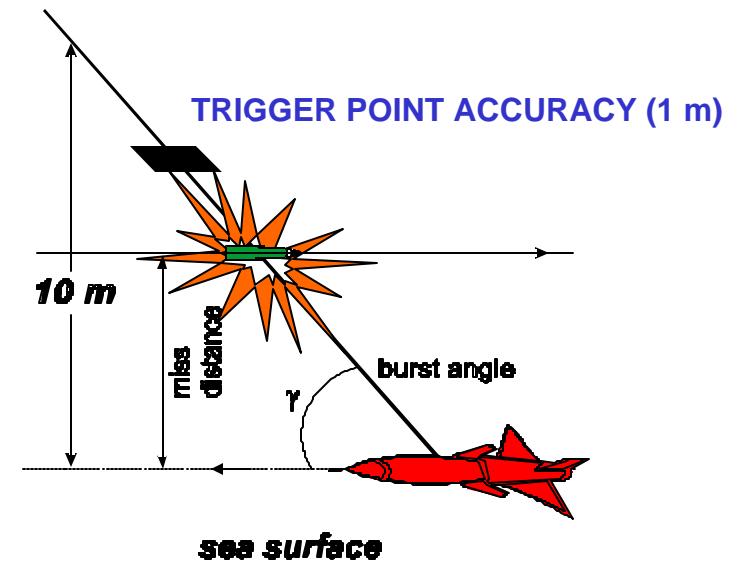
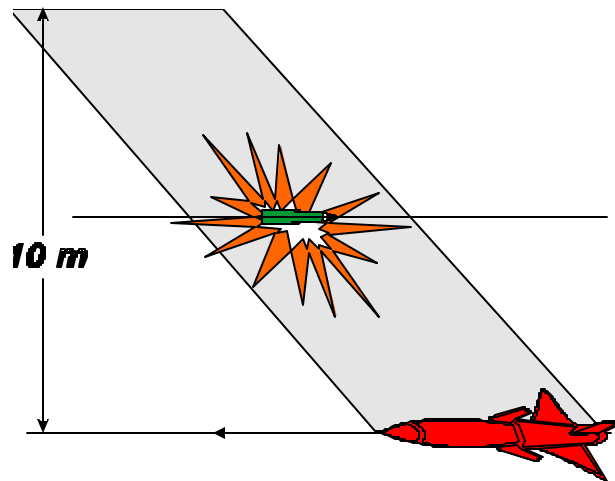

- BURST POINT OPTIMIZATION ACCOUNTING FOR MISS DISTANCE AND RELATIVE INTERCEPTION SPEED
- INSENSITIVE TO SEA CLUTTER
- ECM PROTECTION

# HIGH SENSITIVITY RADIUS

**ACHIEVED BY**

- LOW NOISE SENSOR
- HIGH COMPUTATION CAPABILITY DIGITAL SIGNAL PROCESSOR
- FFT AND PATTERN MATCHING ALGORITHMS

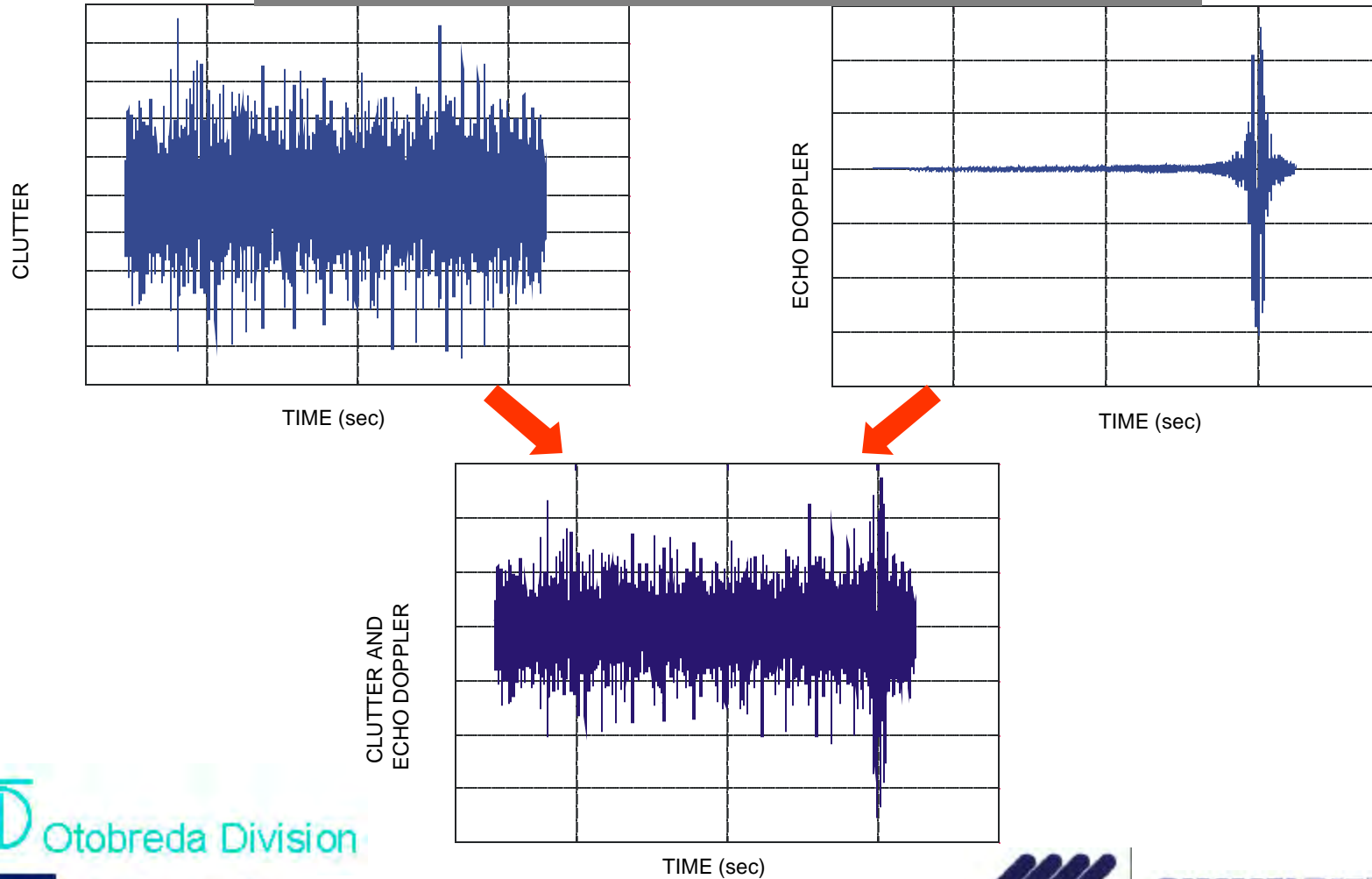

## Microwave Fuze

# REJECTION OF SEA CLUTTER NOISE AND IMPROVEMENT TO TARGET DETECTION RANGE

### BODY ANTENNA FUZE

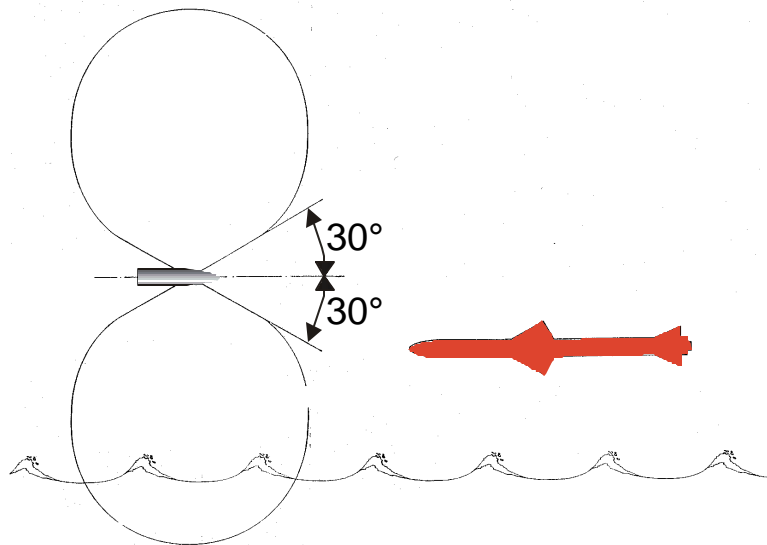

### NEW MICROWAVE FUZE

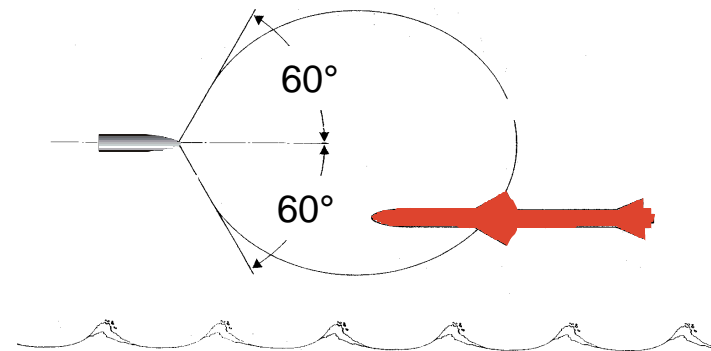

- INCREASE TARGET DETECTION RANGE
- REDUCE CLUTTER NOISE

*Microwave Fuze*

# REJECTION OF SEA CLUTTER NOISE

ACHIEVED BY

- OPERATING NARROW BANDWIDTH ANALYSIS TO SEPARATE TARGET SIGNAL FROM CLUTTER NOISE
- INCREASING FUZE RF FREQUENCY TO INCREASE THE TARGET/CLUTTER SEPARATION

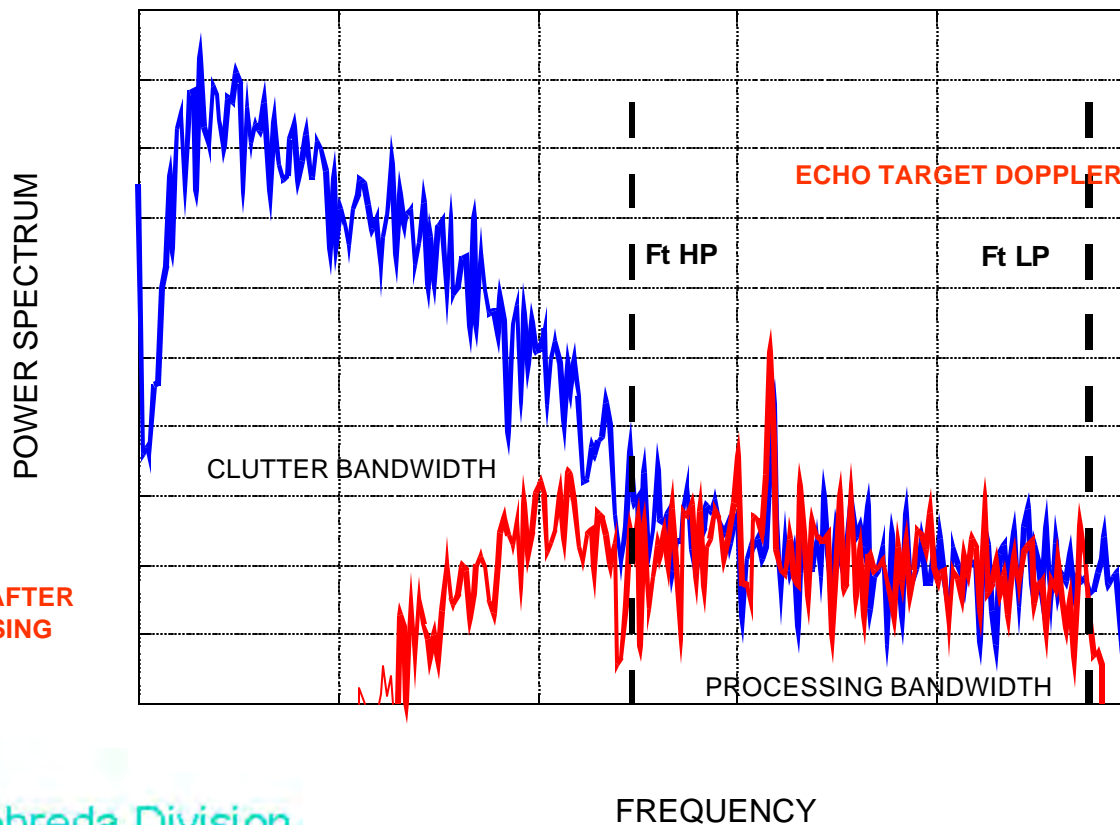

SPECTRUM OF SIGNAL (CLUTTER AND ECHO DOPPLER) RECORDED ABOUT 90 m BEFORE TARGET INTERCEPT

*Microwave Fuze*

## LOW SENSITIVITY TO EM ENVIROMENT

### ACHIEVED BY

- AN ELECTRONIC SETTER MOUNTED ON THE GUN WHICH ENABLES THE FUZE PROXIMITY MODE ONLY IN VICINITY OF TARGET
- USING NARROW BANDWITH SENSOR, ROBUST DIGITAL SIGNAL PROCESSING, ADVANCED SW LOGICS

 Odobreda Division

 **Alenia**  
DIFESA



**SIMMEL**DIFESA

**Microwave Fuze**

## PERFORMANCES IN PRIMARY ROLE

Primary Role	: ANTIMISSILE
Radial Sensitivity	: > 10 m
Action Probability	: > 95%
Level on sea	: down to 2 m

 OtoBreda Division

 **Alenia**  
DIFESA



**SIMMEL**DIFESA

**Microwave Fuze**

# IMPROVEMENTS TO THE “76/62 GUN BASED” SYSTEM

## COMPARISON BETWEEN NEW MICROWAVE FUZE AND BODY ANTENNA FUZES (SEA SKIMMING MISSILE)

	MICROWAVE	BODY ANTENNA
RADIAL SENSITIVITY	> 10 m	3 m
TRIGGERING ACCURACY	1 m	2 m
DETONATION POINT OPTIMIZATION	ACCURATE (1)	COARSE
SEA CLUTTER REJECTION	VERY HIGH	MEDIUM
ECM PROTECTION	VERY HIGH	LIMITED

(1) Function of relative speed and miss distance

*Microwave Fuze*

## FIRING TEST AGAINST LOW ALTITUDE TARGET



TEST LOCATION:  
BALIPEDIO  
"COTTRAU"

LA SPEZIA  
15 JUNE 2000

*8 ROUNDS  
FIRED WITH  
MISS  
DISTANCES  
BETWEEN  
3 AND 6 m*

MOVIE SHOWING 8 FIRINGS

 Odobreda Division

 **Alenia**  
DIFESA



**SIMMEL**DIFESA

# ACCURACY OF BURST POINT

ACHIEVED BY

- HIGH SPEED COMPUTATION FOR SIGNAL FREQUENCY ANALYSIS
- TRIGGER DECISION MADE BY ADVANCED SIGNAL PROCESSING INSTEAD OF TIME/AMPLITUDE ANALOG PROCESSING

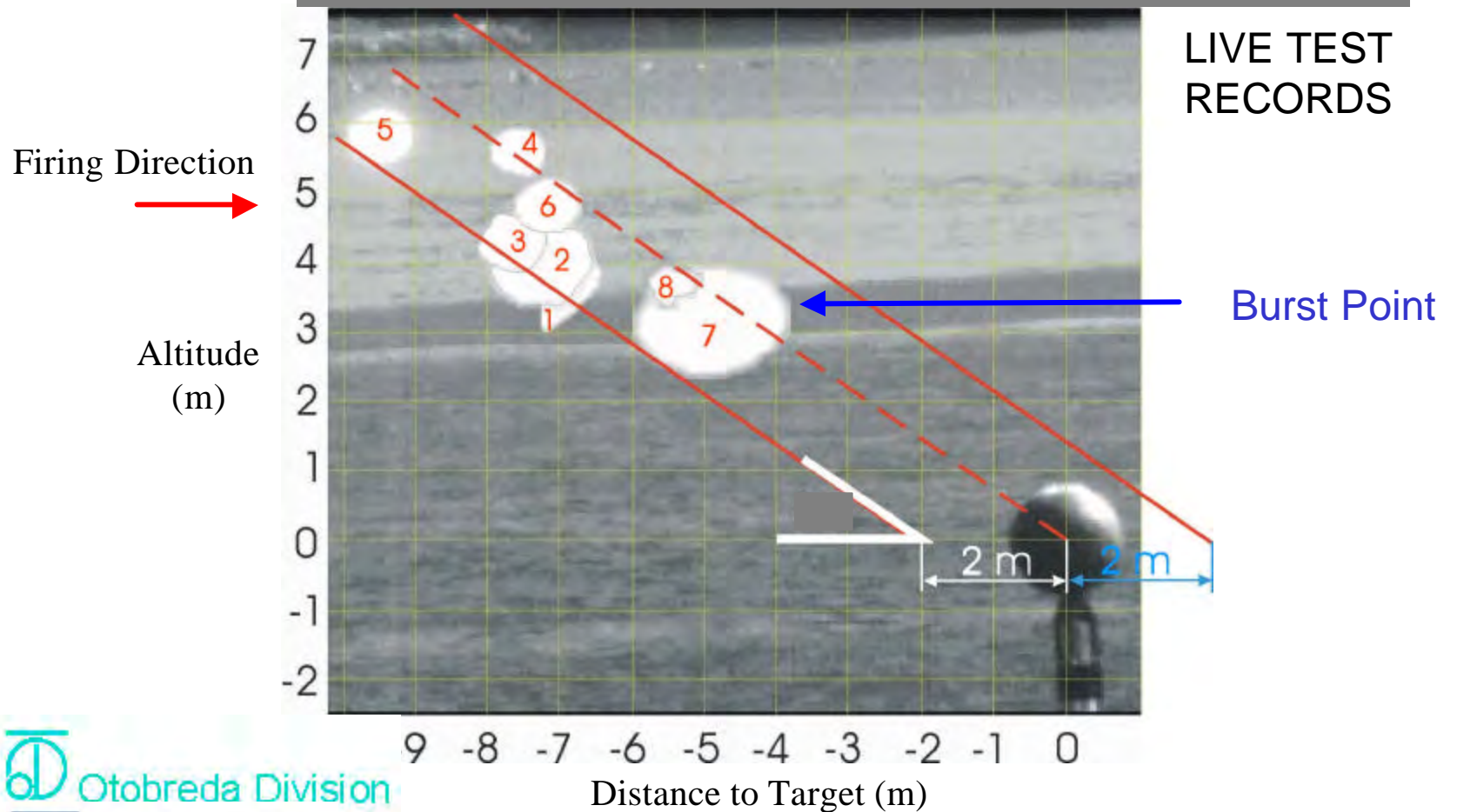

**Microwave Fuze**

**DEVELOPMENT PROGRAM AND INDUSTRIALIZATION**

Nr.	PHASE	96-97	1998	1999	2000	2001	2002	2003	2004	
1	DEVELOPMENT									
2	INDUSTRIALIZATION AND QUALIFICATION									
3	EARLY DELIVERIES									



# **JUNGHANS** Feinwerktechnik



# **Optronic Mortar Proximity Fuze PX581**

**Presentation for 45th Annual Fuze Conference  
April 17, 2001  
Long Beach, CA**

**by Peter Becker\*, Dr. Gerhard Nowicki,  
Dr. Ulrich Obbarius, Frank Kienzler**



# Cooperation Noptel – JUNGHANS



**noptel**

**JUNGHANS**  
Feinwerktechnik



## Basis of the cooperation NF2000M



**noptel**



**JUNGHANS**  
Feinwerktechnik



## Reason for the cooperation

Adjoining the technical specialities of JUNGHANS and Noptel



- Optronic distance measurement



- Fuze design
- Safety concept
- Mechanics
- Fuze assembly





## Product Program

Fuzes for  
Medium Caliber Ammunition

Mortar Fuzes

Fuzes for  
Tank Gun Ammunition

Fuzes for  
Rockets and Missiles

Artillery Fuzes

Fuzes for  
AT-Weapon Ammunition

Safety and  
Arming Devices

Miscellaneous Products

# Mortar Fuze



**DM93 / M776**

**MTSQ Fuze**

**M772**

**MTSQ Fuze**

**DM111A4**

**PD Fuze**

**DM111A5**

**PD Fuze**

**PX581**

**PROX Fuze**

## PX581 Optronic Proximity Fuze



- PROX (backup SQ and delay)
- 60, 81, 120 mm HE, SMK bombs
- Preset height 1, 2, 3, 4 or 5 m
- MIL STD 1316D
- Muzzle safety distance  $\geq 100\text{m}$
- Trajectory safety: APEX
- $\geq 98\%$  reliability (95% prob.)
- $-40^{\circ}\text{C}$  ( $-46^{\circ}\text{C}$ ) to  $+63^{\circ}\text{C}$



# PX581 Optronic Proximity Fuze

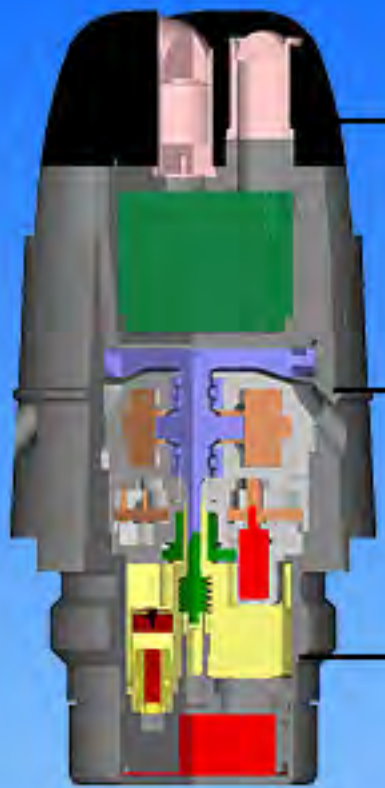

**Optronics & SQ-Switch  
Evaluation Electronic**

**Wind Turbine  
Energy Generator**

**S&A  
Explosive Chain**



Product Program	Product Group	Product	Components	Animation
Status	Trajectory			

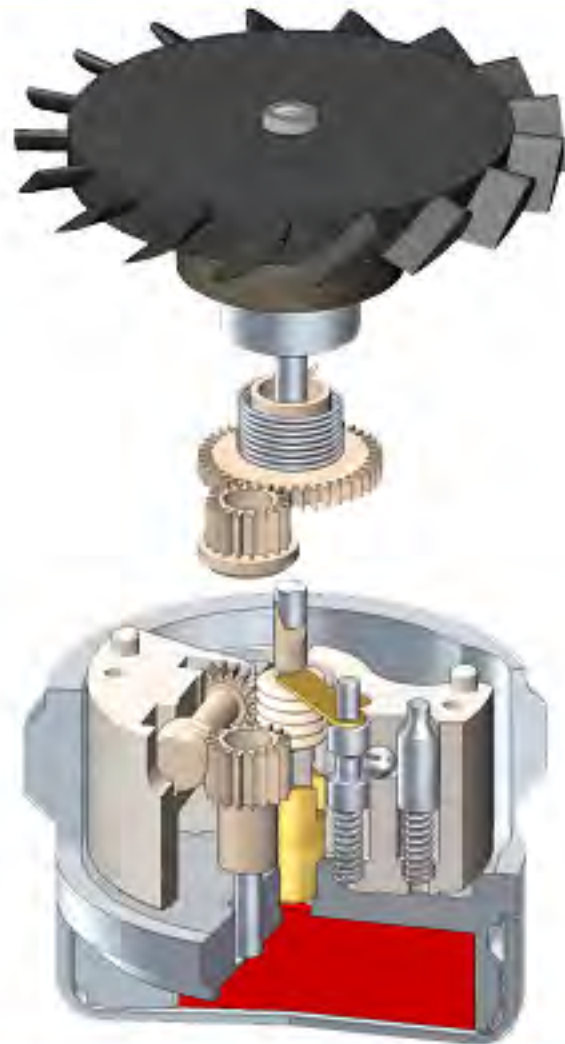

S&A  
Proximity / PDSQ  
PD-Backup



Product Program	Product Group	Product	Components	Animation
Status	Trajectory			

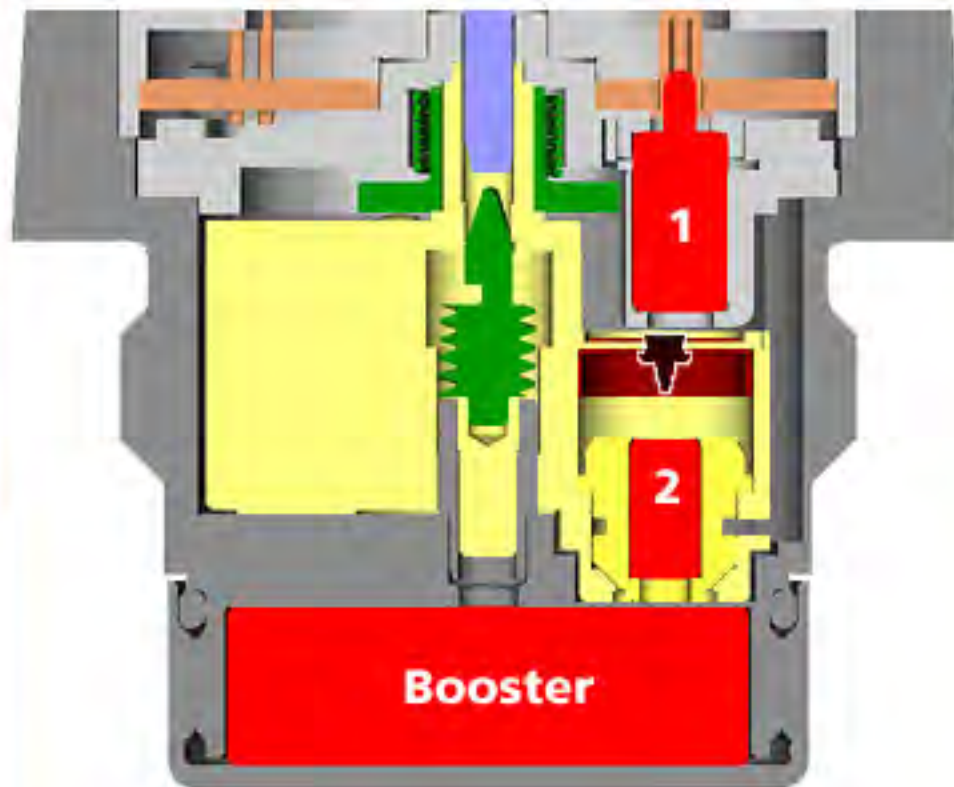

S&A

Proximity

PD

Product Program

Product Group

Product

Components

Animation

Status

Trajectory

A Company of  
Diehl VA Systeme

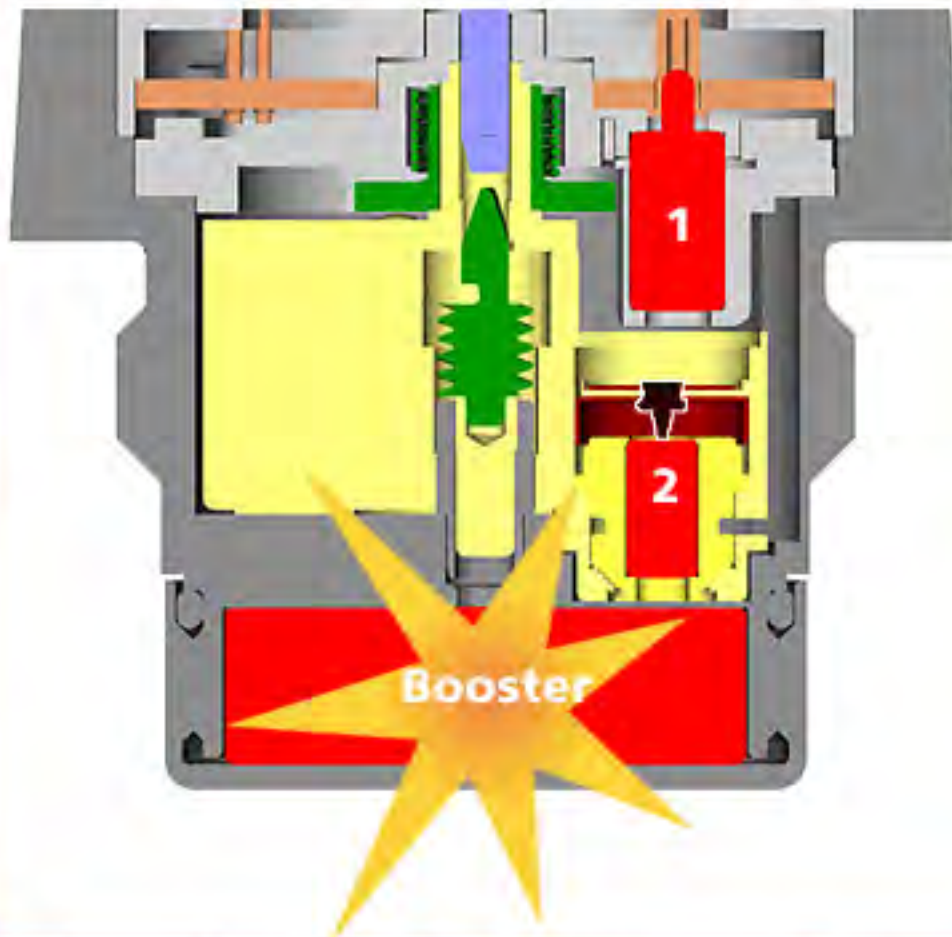

- S&A
- Proximity
- PD



Product Program	Product Group	Product	Components	Animation
Status	Trajectory			

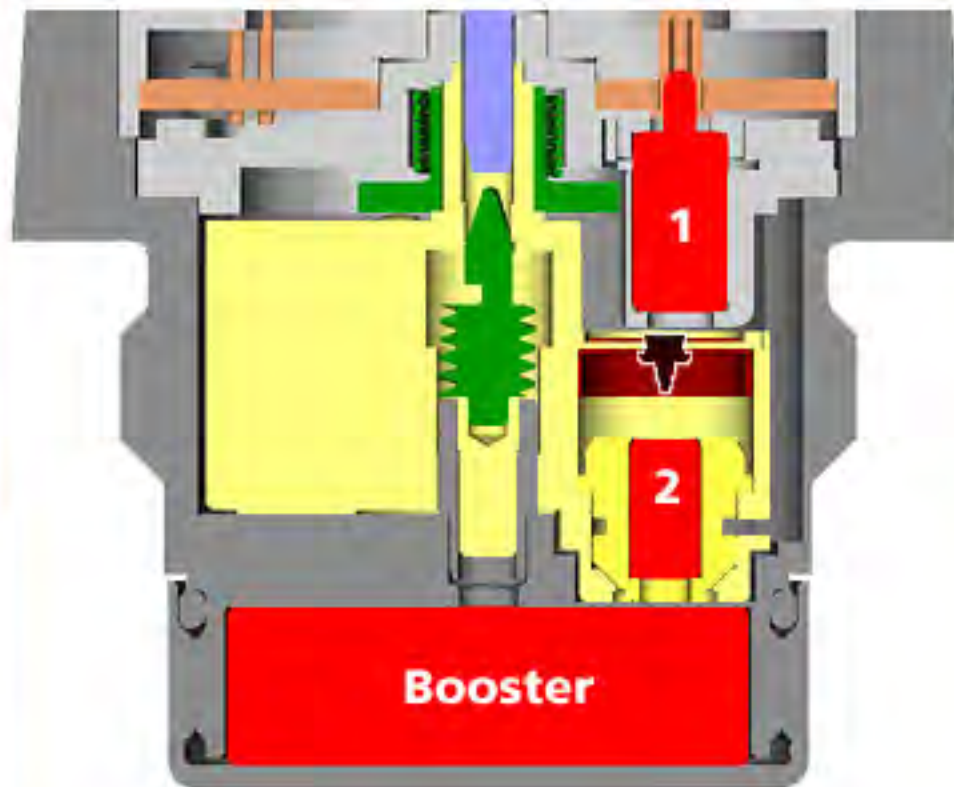

S&A  
Proximity  
PD

Product Program    Product Group    Product    Components    Animation  
Status    Trajectory

A Company of  
Diehl VA Systeme

# IMPACT!

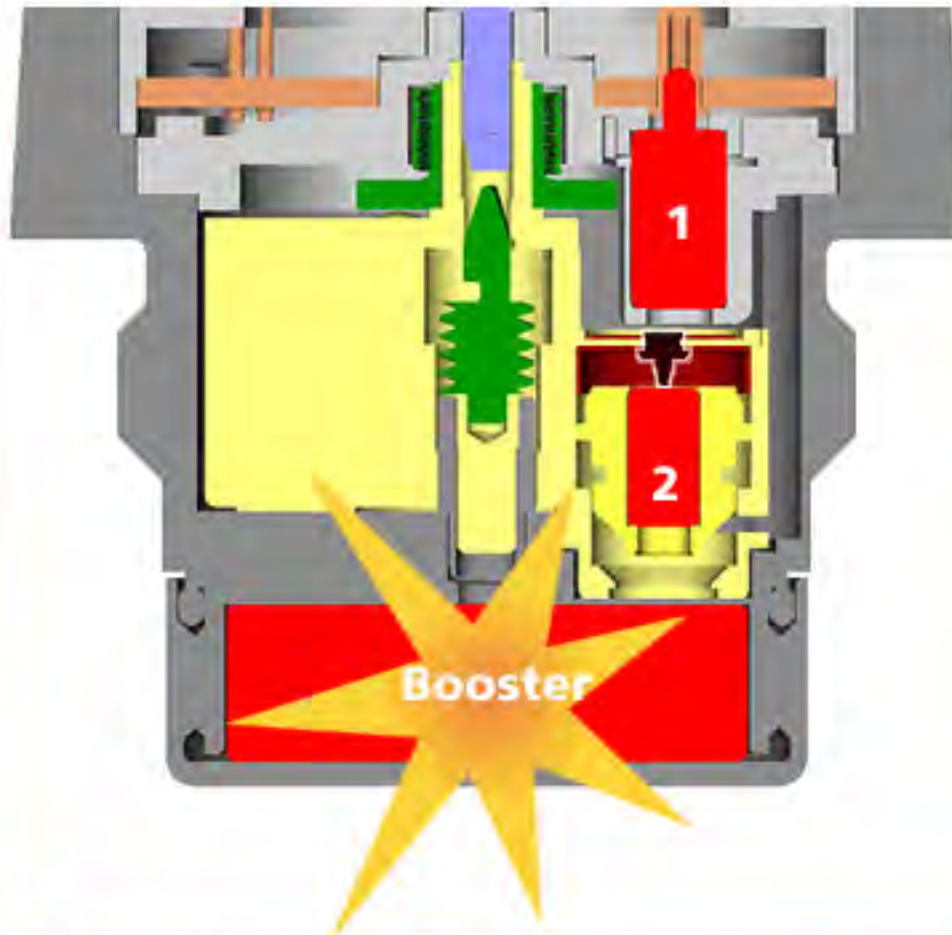

- S&A
- Proximity
- PD



Product Program	Product Group	Product	Components	Animation
Status	Trajectory			

# PX581 Optronic Proximity Fuze

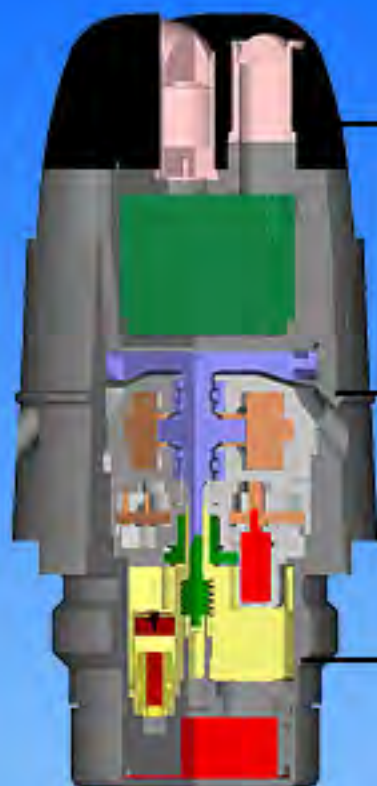

**Optronics & SQ-Switch  
Evaluation Electronic**

**Wind Turbine  
Energy Generator**

**S&A  
Explosive Chain**



# PX581 Optronic Proximity Fuze

■ Optronics &  
SQ-switch  
Evaluation  
electronic



**Preset heights  
ex works**

**1, 2, 3, 4,  
or 5 meters  
± 1 meter**



Product Program

Product Group

Product

Components

Animation

Status

Trajectory

A Company of  
Diehl VA Systeme

# PX581 Optronic Proximity Fuze

- Optronics & SQ-switch Evaluation electronic



Preset heights  
ex works

1, 2, 3, 4,  
or 5 meters  
 $\pm 1$  meter



Product Program	Product Group	Product	Components	Animation
Status	Trajectory			

# PX581 Optronic Proximity Fuze



■ **Distance measurement with IR beam**



Product Program	Product Group	Product	Components	Animation
Status	Trajectory			



# PX581 Optronic Proximity Fuze



■ Distance measurement with IR beam



Product Program	Product Group	Product	Components	Animation
Status	Trajectory			

# PX581 Optronic Proximity Fuze



**Not jammable**

--	--	--	--	--

■ Distance measurement with IR beam



Product Program	Product Group	Product	Components	Animation
Status	Trajectory			

# PX581 Optronic Proximity Fuze

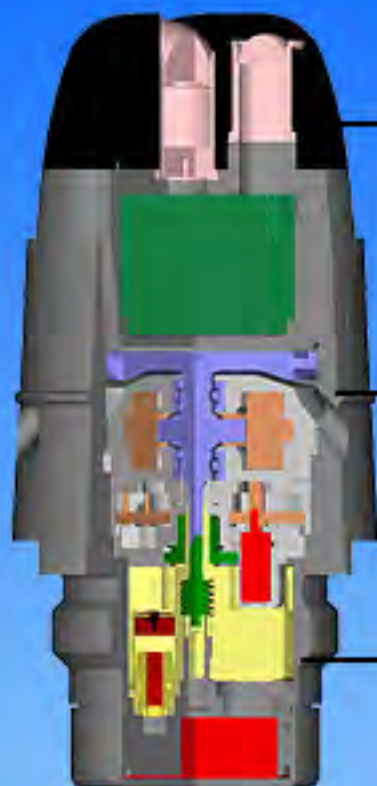

**Optronics & SQ-Switch  
Evaluation Electronic**

**Wind Turbine  
Energy Generator**

**S&A  
Explosive Chain**



# PX581 Optronic Proximity Fuze

■ Wind turbine  
Energy  
generator

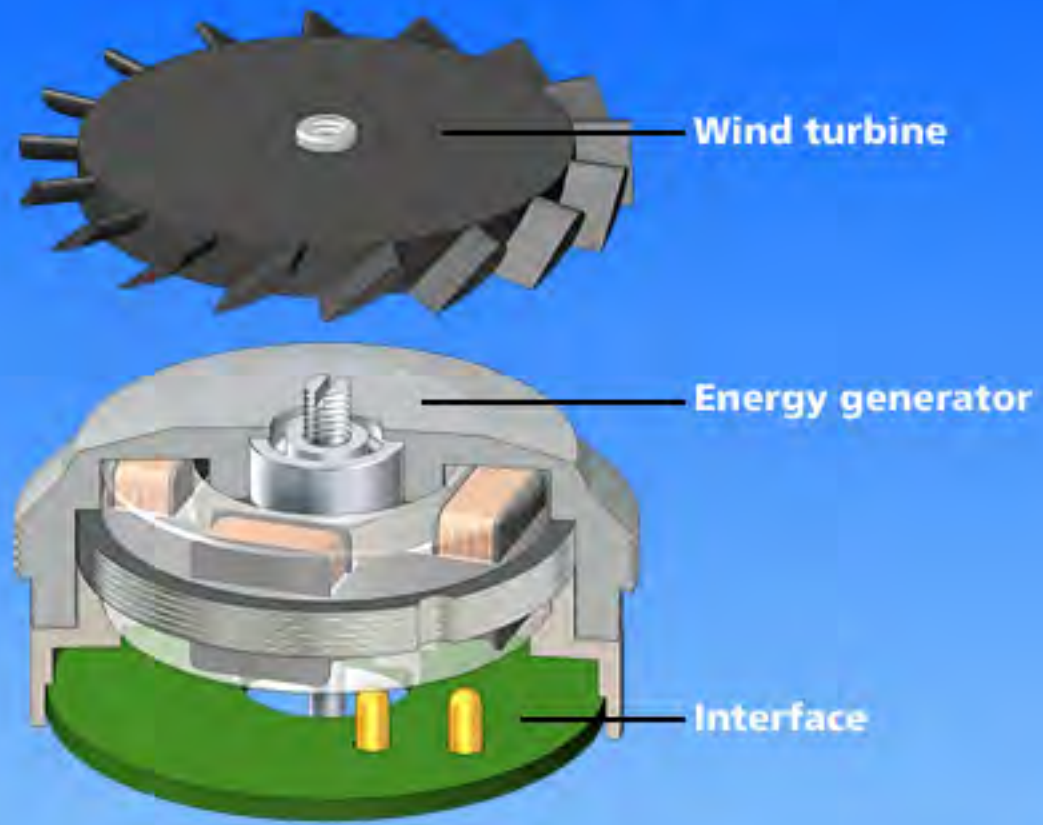

Product Program	Product Group	Product	Components	Animation
Status	Trajectory			

# PX581 Optronic Proximity Fuze

100 m  
mechanical  
safety

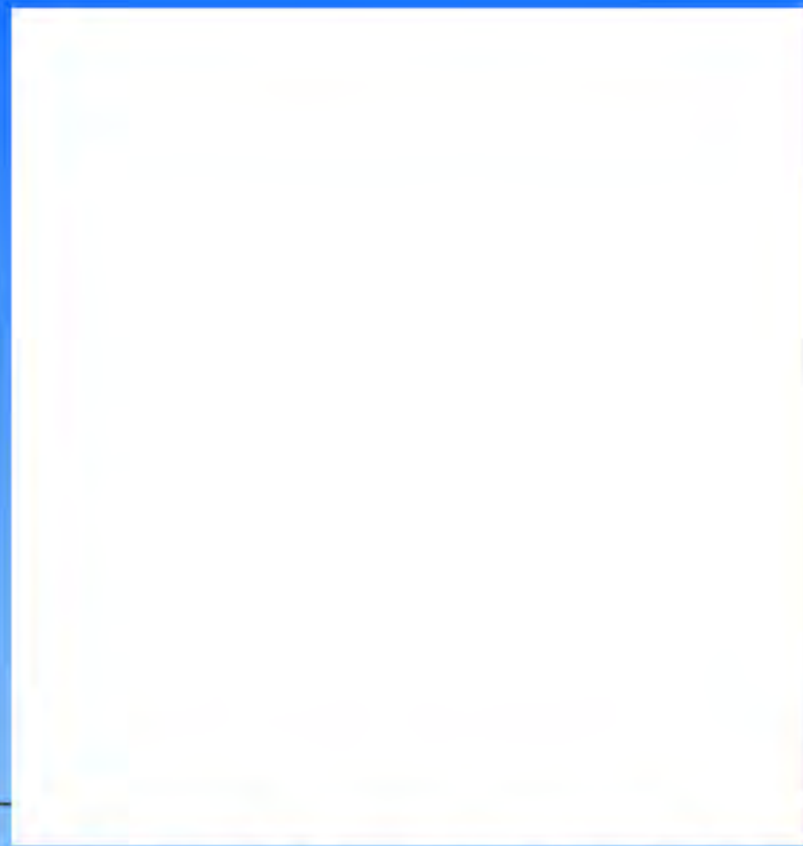

Product Program	Product Group	Product	Components	Animation
Status	Trajectory			

# PX581 Optronic Proximity Fuze

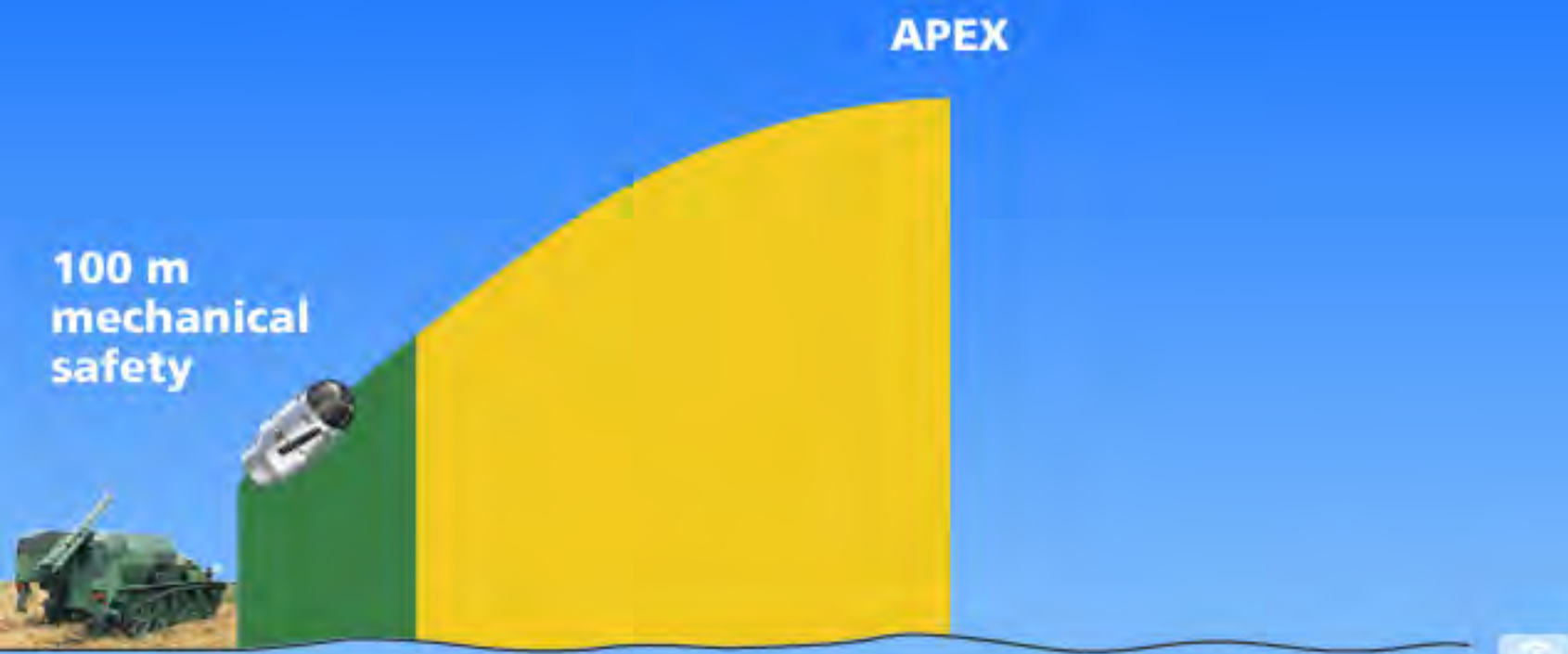

Product Program	Product Group	Product	Components	Animation
Status	Trajectory			

# PX581 Optronic Proximity Fuze

**Not jammable**



**APEX**

**100 m  
mechanical  
safety**



Product Program	Product Group	Product	Components	Animation
Status	Trajectory			

# PX581 Optronic Proximity Fuze

## Status

- **Development**  
various subassembly and firing tests: until 06/2001
- **Company qualification: 10/2001**
- **Start of series production: 04/2002**



Product Program	Product Group	Product	Components	Animation
Status	Trajectory			

# Conclusion



- **Most modern fuze design**
- **Usable with  
60 / 81 / 120 mm Ammo**
- **Highly precise distance  
measurement**
- **Not jammable**
- **No stored energy**
- **Two independent  
safety criteria**
- **In production from 2002 on**



*The Reactive Bridge: A Novel  
Solid-State Low Energy Initiator*



Dr. Thomas A. Baginski (Auburn University)

David Fahey (Quantic Industries)

# *EED Structure*

- Conductive Pins
- Header and Cup
- Bridgewire
- Primary Charge
- Output Charge

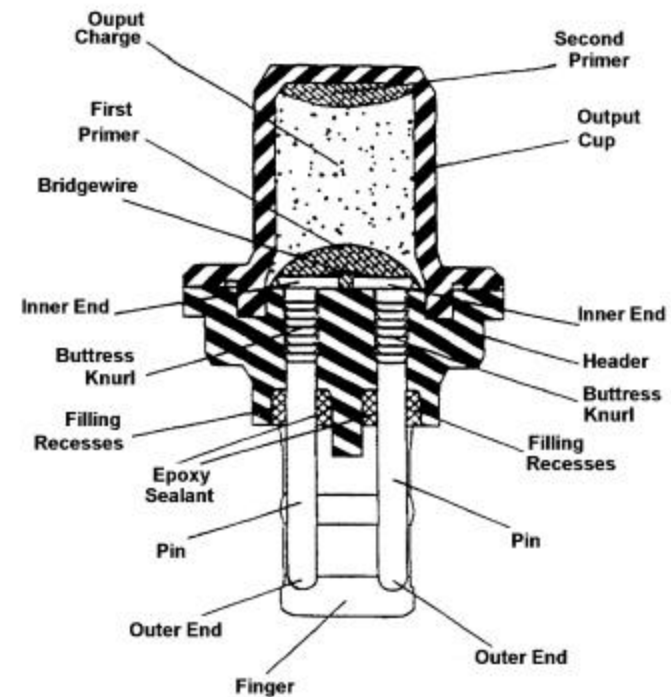

# *Reactive Bridge vrs. Bridgewire*

- Faster Actuation ( $<5\mu\text{sec}$ )
- Lower Firing Energy ( $<30\mu\text{J}$ )
- Smaller Dimensions (Feature size  $<20\mu\text{ms}$ )
- Reliable Ignition Across Airgap
- Insensitive to ESD
- Fabricated with Conventional Microelectronic Processes

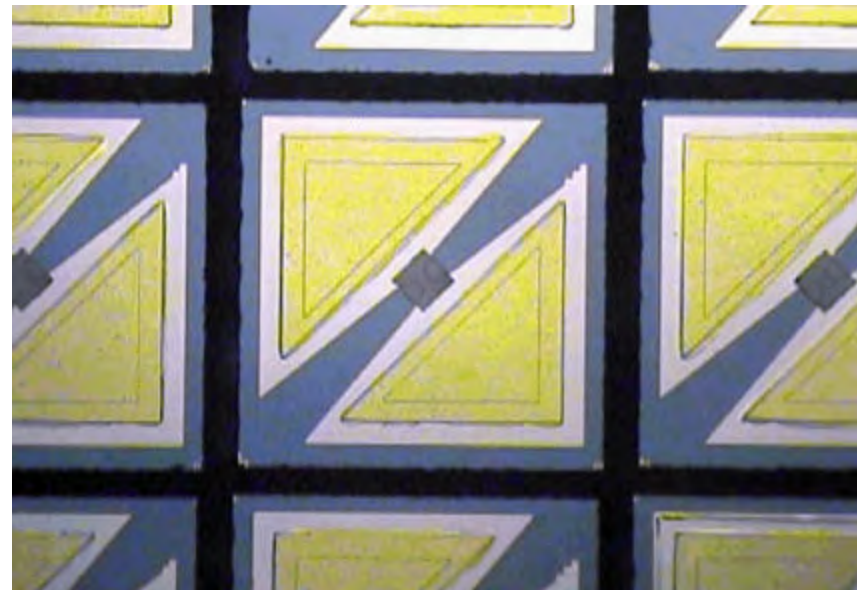

# *Design Model*

- Resistive Heating Element ( $1\Omega - 10\Omega$ )
- Two PN Junction Diodes in Parallel for ESD Protection (Breakdown Voltage  $\sim 4V \Leftrightarrow 20V$ )

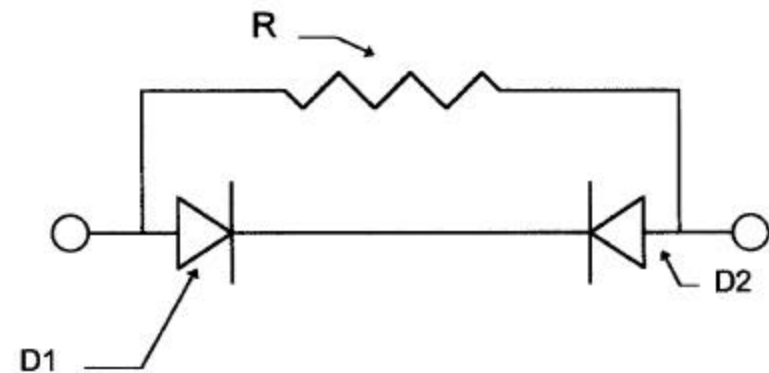

# *Composite Reactive Bridge Fabrication*



- Utilizes Basic Fabrication Techniques
- Photolithography
- Wet Chemical Etching
- Sputtering and E-beam Metal Deposition
- Liftoff Process

# *Implant and Diffusion*

- Etch Oxide Window using BOE
- Typical Ion Implant
  - B
  - $Q = 5E15/cm^2$
  - Energy = 50keV
- Typical Drive-In
  - 1000°C, N<sub>2</sub>
  - 15 minutes

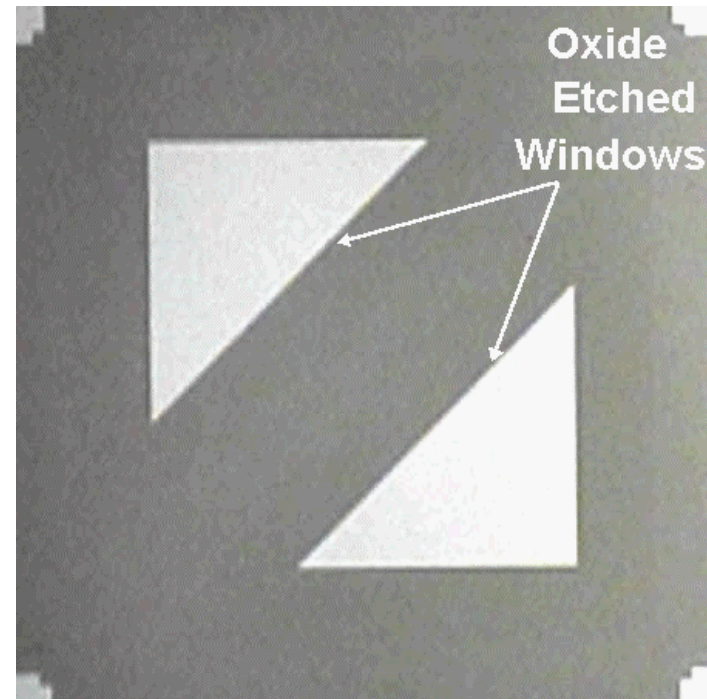

# *Aluminum Deposition*

- Sputter  $\sim 12,000\text{\AA}$  of Si/Al
- Mask off Window
- Etch Al with PAE
- Etch Residual Si
- Alloy Al at  $450^\circ\text{C}$  for 30 minutes

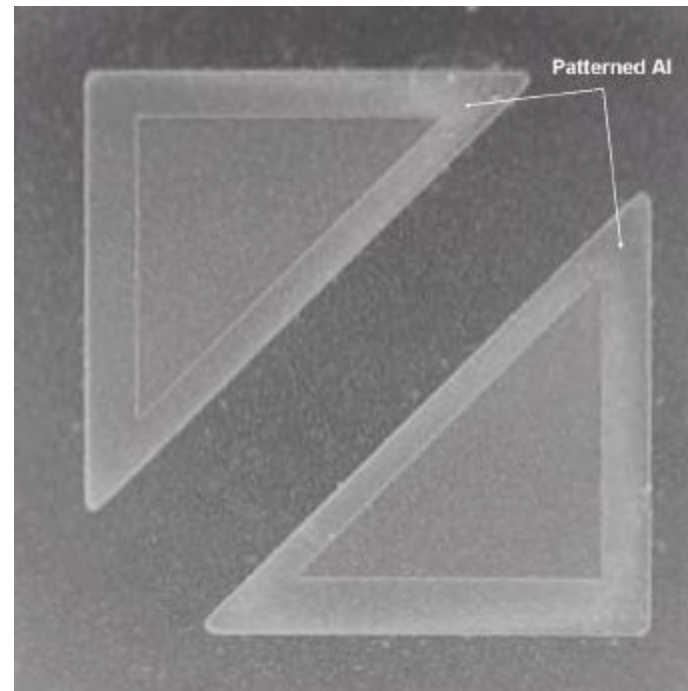

# *Palladium Deposition*

- Mask and Develop
- Deposit
  - 500Å of Ti
  - 2000Å of Pd
- Liftoff
  - Ultrasonic and Acetone

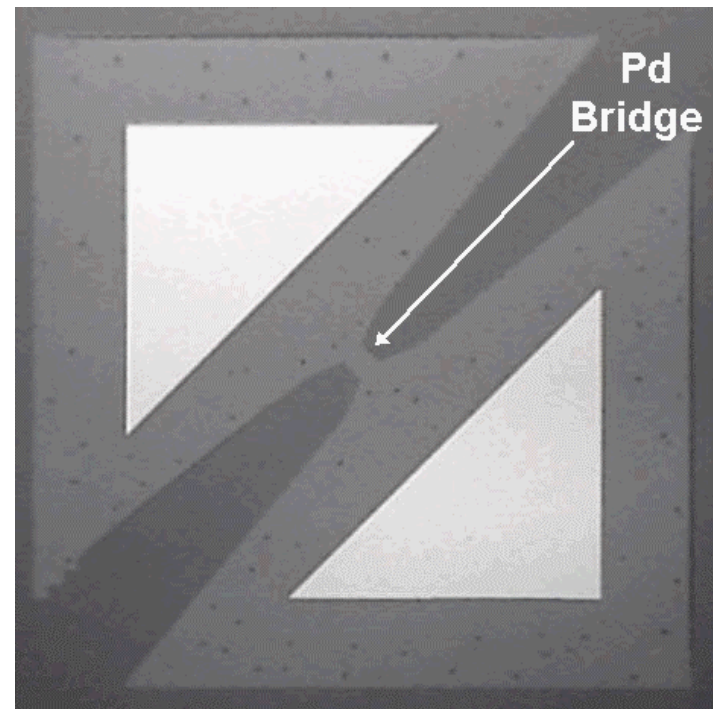

# *Gold Deposition*

- Mask and Develop
- Deposit
  - 500Å of Ti
  - 1000Å of Ni
  - 2000Å of Au
- Liftoff
  - Ultrasonic and Acetone

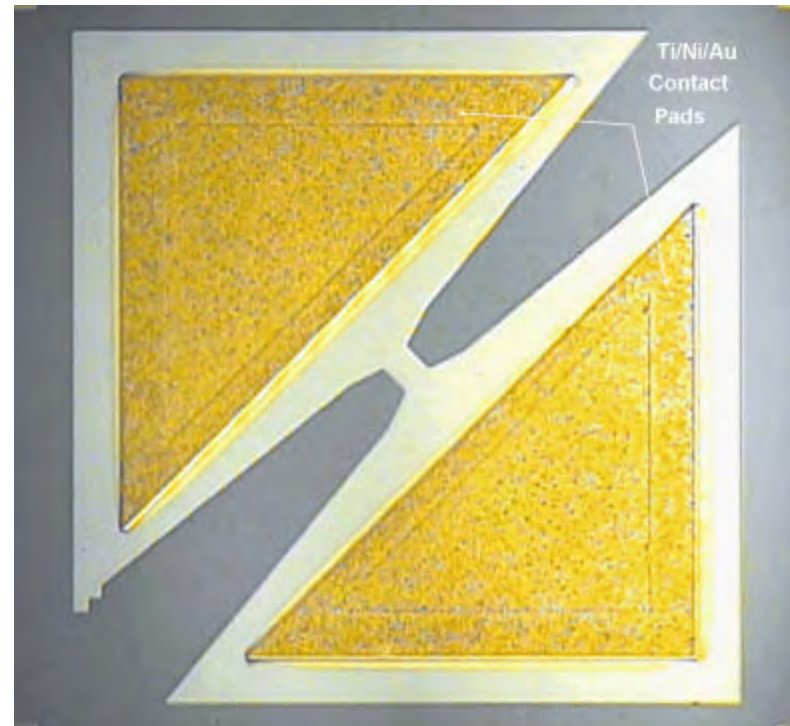

# *Zirconium Deposition/Reactive Overcoat*

- Mask and Develop
- Deposit
  - 500Å of Ti
  - 10,000Å of Zr
- Additional Mass for Plasma Formation
- Chemically Reactive
- Liftoff
  - Ultrasonic and Acetone

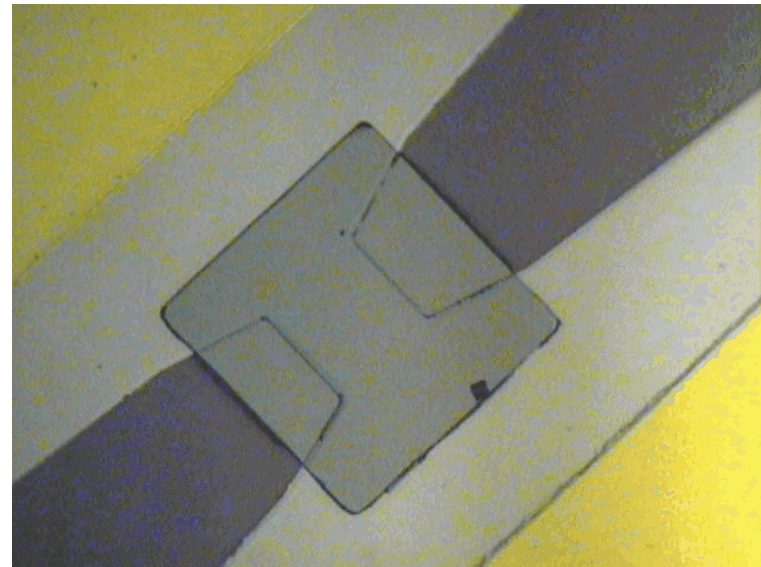

# Typical Dimensions

- ~1mm x 1mm, overall size
- $15\mu\text{m}^2$  -  $40\mu\text{m}^2$ , varying bridge size
- $100\mu\text{m}^2$ , overcoat size

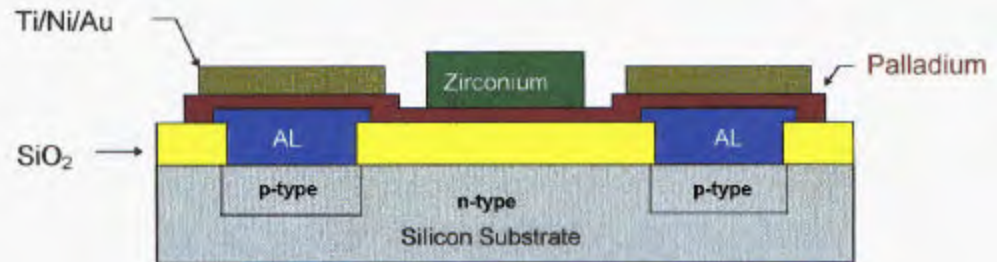
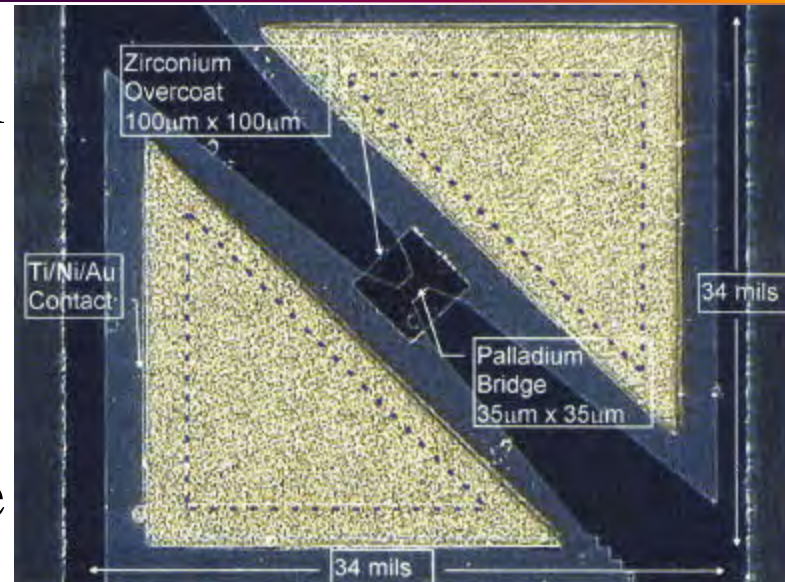

# Packaging

- ValoxDR48 Plastic Header
- Conducting Pins
- Output Cup



# *Design Validation Testing*

- Firing Current  
Proportional to Bridge  
Size

- Firing Energy,

$$Q = \int_0^t (I^2 R) dt$$

- I = Firing Current
- R = 2Ω (bridge)
- t = .1msec

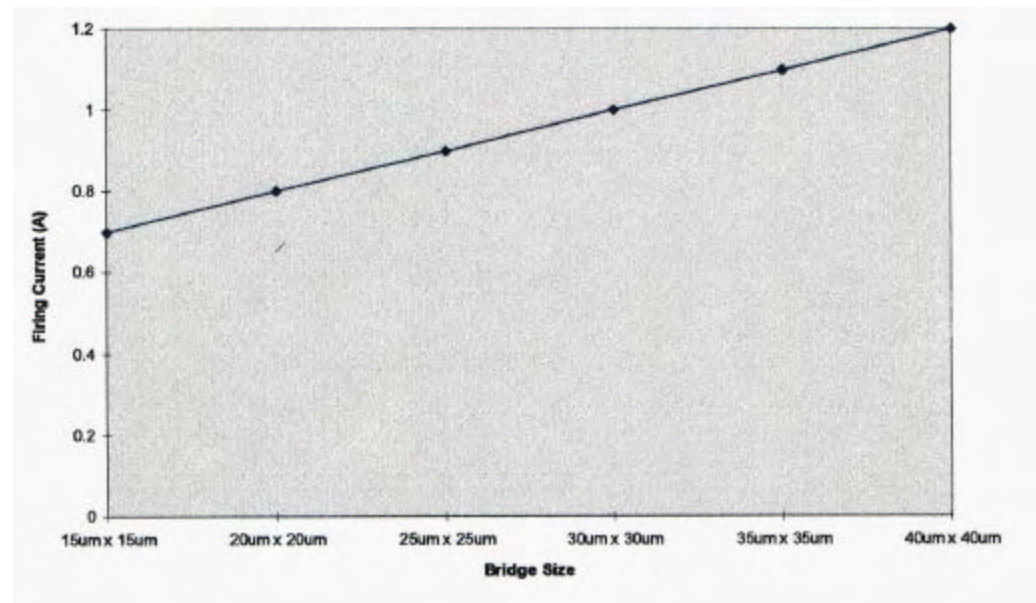

*Firing Results With  
Without Overcoat 2mF @ 30V*

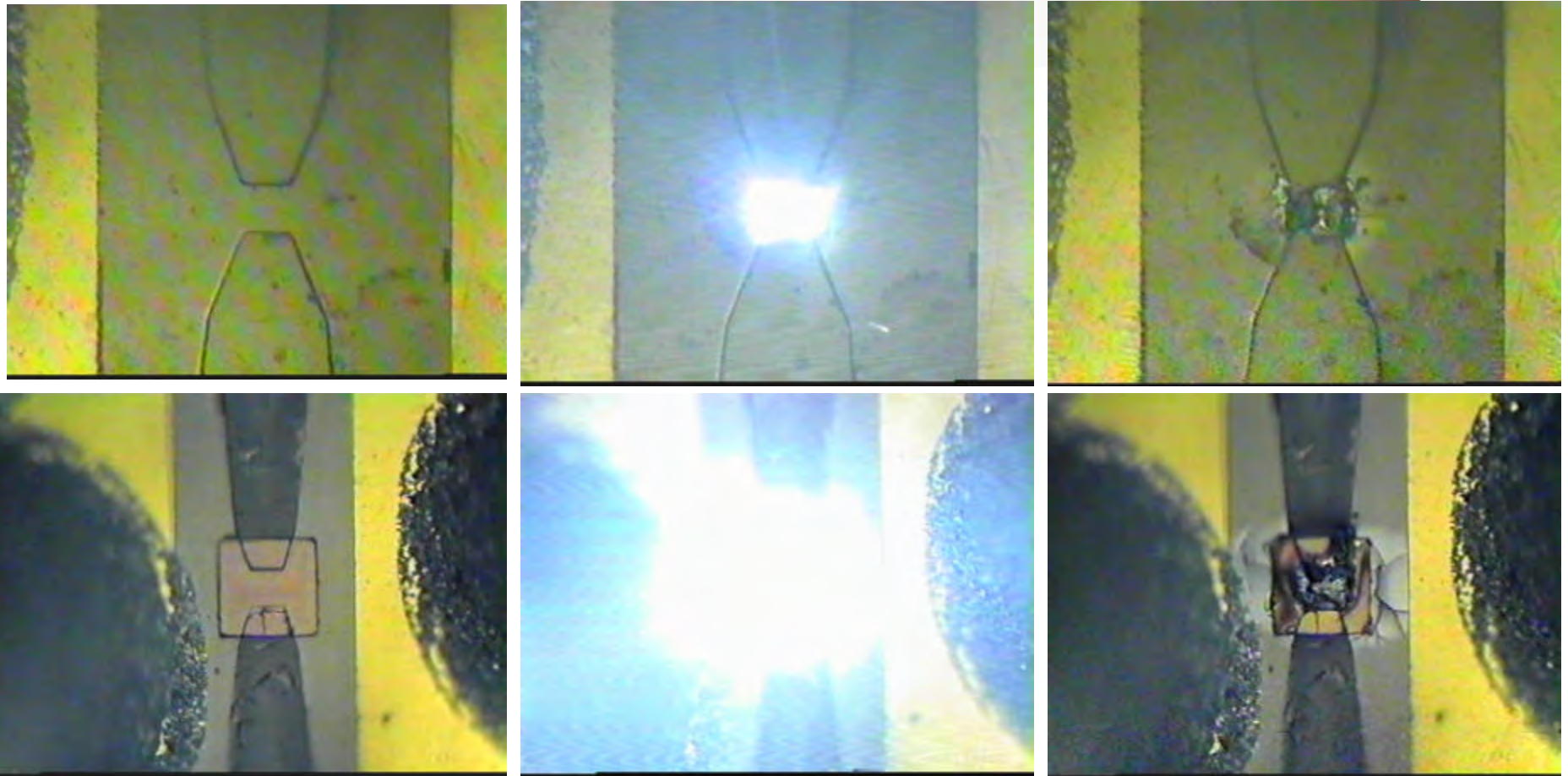

# *ESD Test Setup*

- 150pF Capacitor Charged to 25kV
- Series Resistor of 150Ω
- Close Switch
- Repeat 5 times

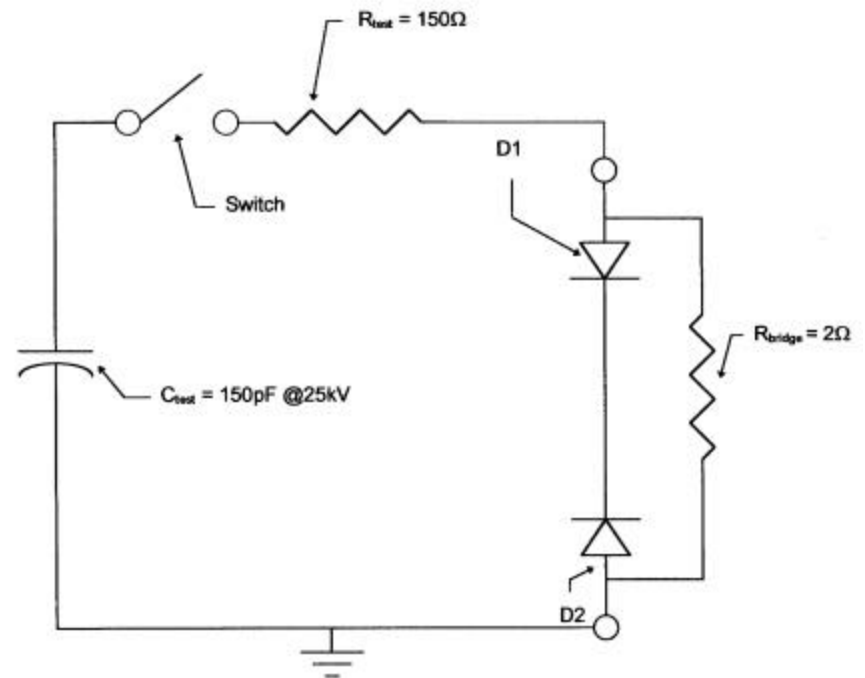

# *Environmental Test Setup*



- 320 Parts
- High Temp, 144 hrs @ 107°C
- Thermal Shock and Humidity
  - 6 cycles(-40°C and 107°C) for 12 hrs
- Random Vibration
  - Method S14:4 category I
  - 3 perpendicular axis, -40°C, 21°C, and 90°C

# All Fire/No Fire Data

## All Fire / No Fire Summary

Group	Bond	AF @ 1ms, 99.999% @ 95% Confidence -40C	AF @ 1ms, 99.999% @ 95% Confidence +21C	NF @ 10s, 99.999% @ 95% Confidence +90C	NF @ 10s, 99.999% @ 95% Confidence +21C
Baseline	Wirebond	1.037A	NA	.583A	NA
Post Serial Environ.	Wirebond	1.039A	NA	.617A	NA
Baseline	Conductive Epoxy	1.026A	NA	.613A	NA
Post Serial Environ.	Conductive Epoxy	1.040A	0.997A	.613A	.605A

# *Validation Testing Results*



- Results Extremely Positive
- 1.2A, 1msec all-fire
- 0.5A, 10s no-fire
- 99.999% reliability, 95% confidence
- Time to Peak Pressure, < 1ms

# *The Laminated Reactive Bridge*



- Structure employs laminations of B/Ti
- Exothermic inter-metallic alloy
- No oxidizer required
- $2\text{B} + \text{Ti} \Rightarrow 1320\text{cal/gm}$

# Laminated Reactive Bridge

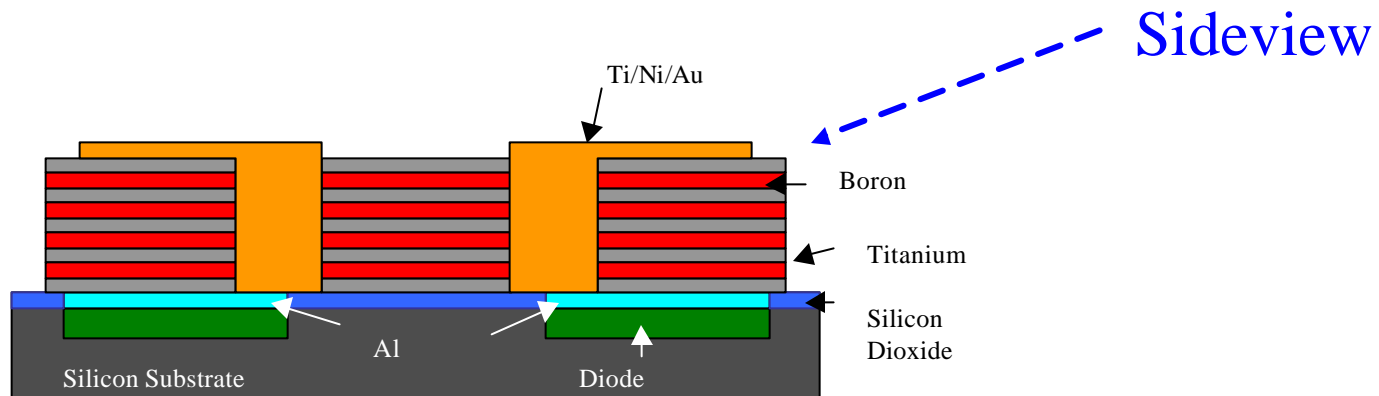
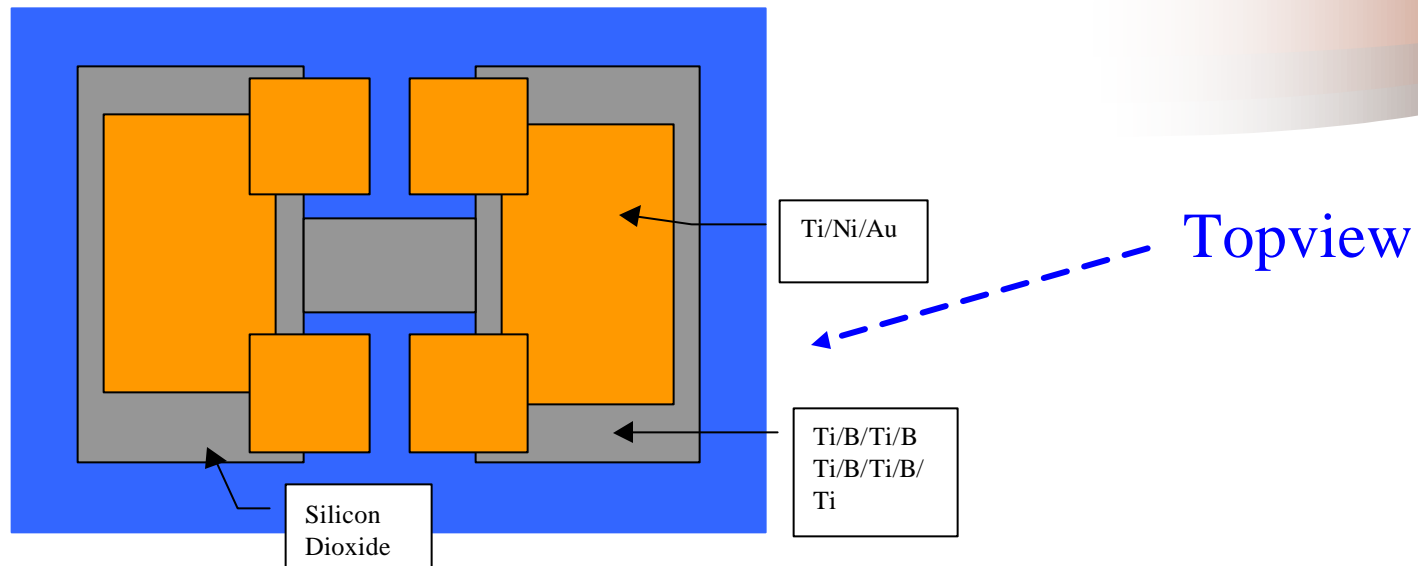

# *Sample Firing Of Laminated 110mm Bridge 35mF @ 30V*



← 4cm →



← 4cm →

# Firing Current Waveforms

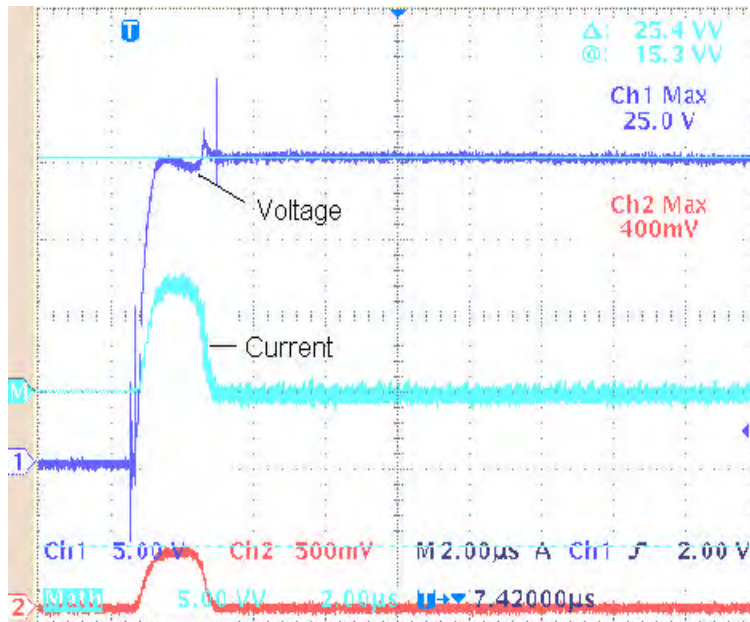

Typical Firing Trace of a Composite Bridge  
(30 μm bridge)

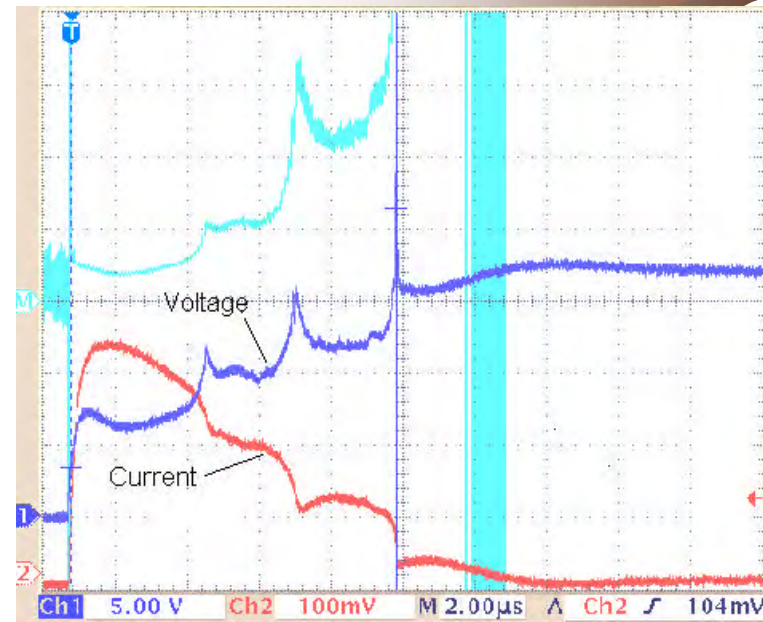

Typical Firing Trace of a Laminate Bridge  
(30 μm bridge)

# *Firing Characteristics of Laminated Bridge with 5W ESR*

MEAN FIRING VOLTAGE AND ENERGY VERSUS CAPACITOR SIZE

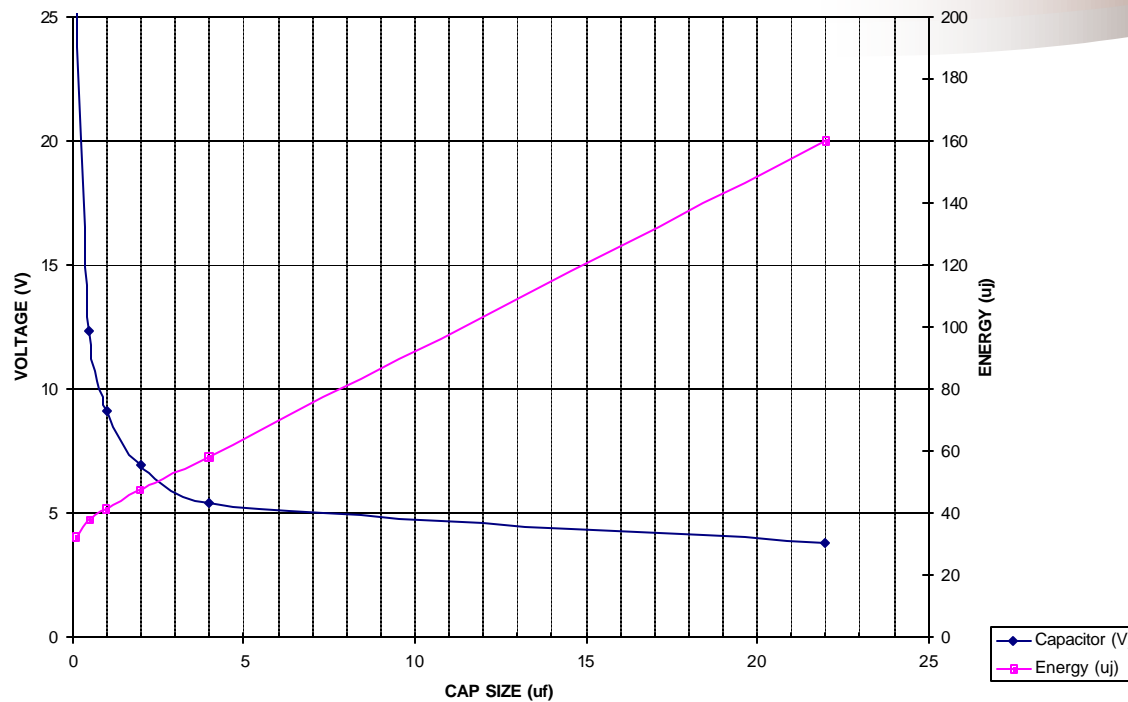

A plot of firing voltage and energy for a 20  $\mu\text{m}$  Laminated bridge

# *Firing Data for Laminated Bridge*

**Reactive SCB Mean Firing Voltage Vs  
Capacitance & Bridge Size**

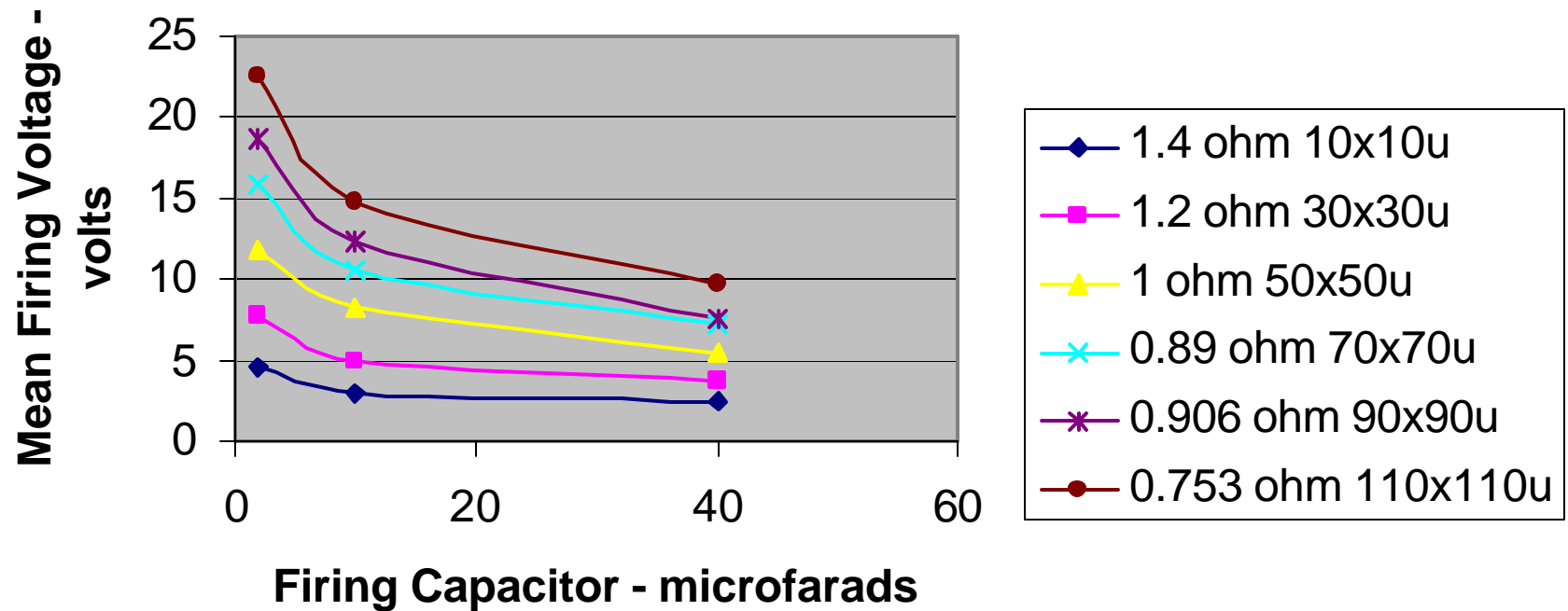

# *ESD Results for Laminated Bridge*

## ESD Threshold Voltage (500pf 5K ohm)

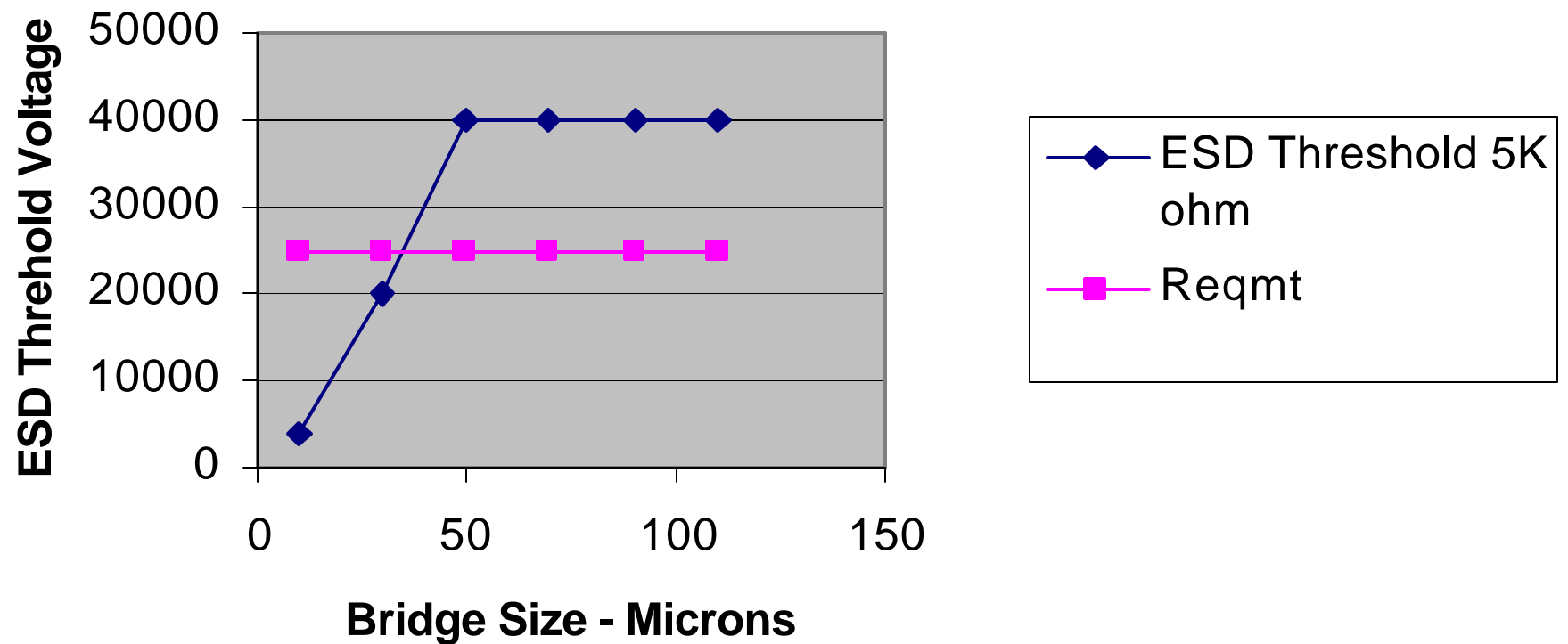

# *Integrated Shaped-Charge*

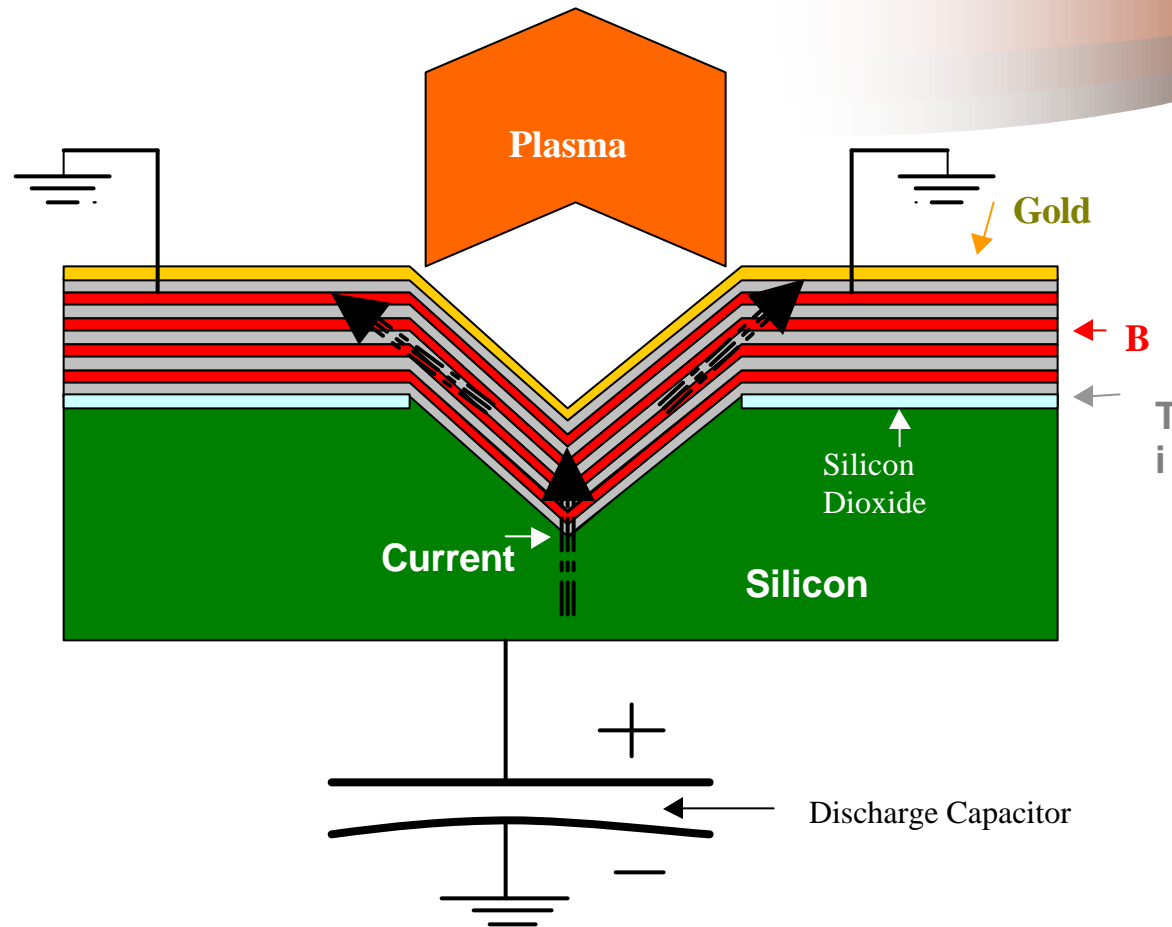

# *Conclusion*



- Devices Fabricated Using Conventional Techniques
- Demonstrates Lower Firing Energy
- Diodes Protect Against ESD Events
- Reliably Fires in Less Than 1 $\mu$ sec
- Plasma Output Capable of Jumping a Gap
- Very Economical for Large Volumes



# *Fuzing at Dahlgren*

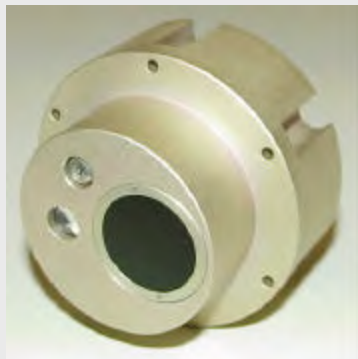

**Michael A. Till**  
**NSWC Dahlgren Division**  
**G34, Fuze Branch**

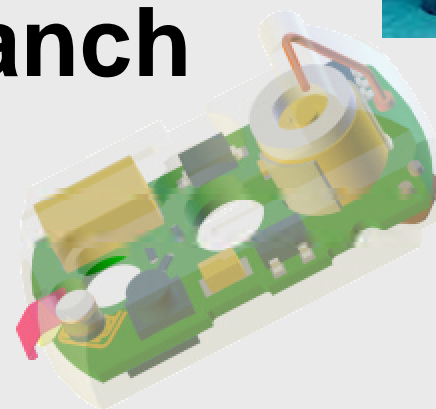
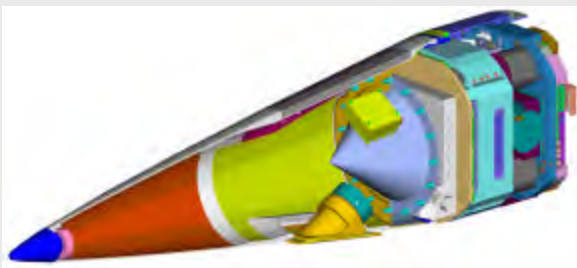

# ERGM System Description

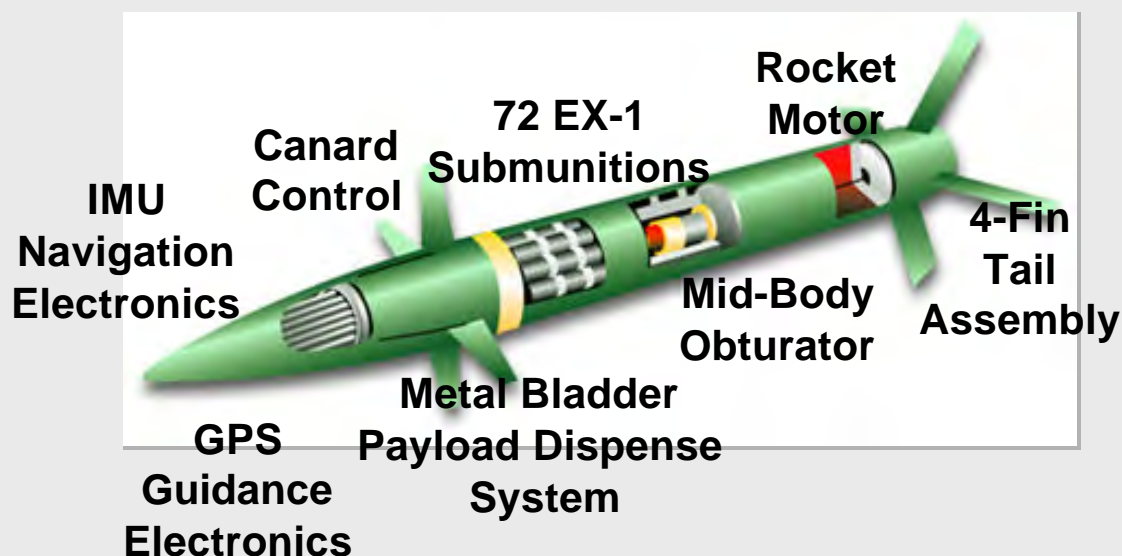

- Roll-Attitude Controlled Airframe
- Vertical Endgame Trajectory

- ❑ Length: 61 Inches
- ❑ Weight: 110 Pounds
- ❑ **Fuze: Integral, GPS Initiated**
- ❑ **Guidance: GPS/INS**
- ❑ Accuracy: <20m CEP
- ❑ Payload: Submunitions
  - 72 EX-1s (Modified M80s)
  - **Self Destruct Fuze (M234)**
- ❑ Propulsion: Rocket Motor
- ❑ Range Objective: 63 nmi
- ❑ Prop Charge: 18 MJ
- ❑ Loading: Double Ram

# ERGM Mission Profile

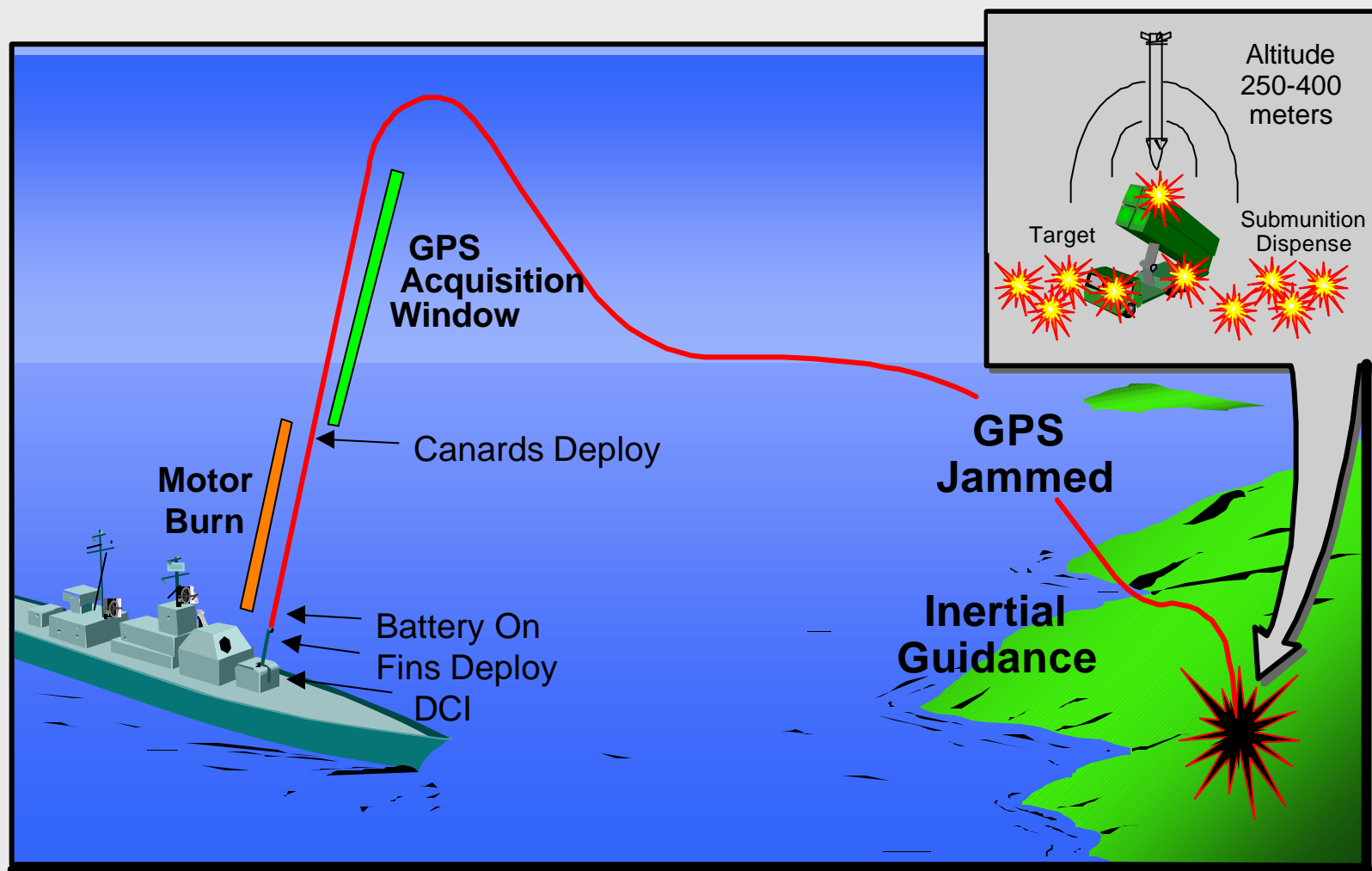



# ERGM Payload Section

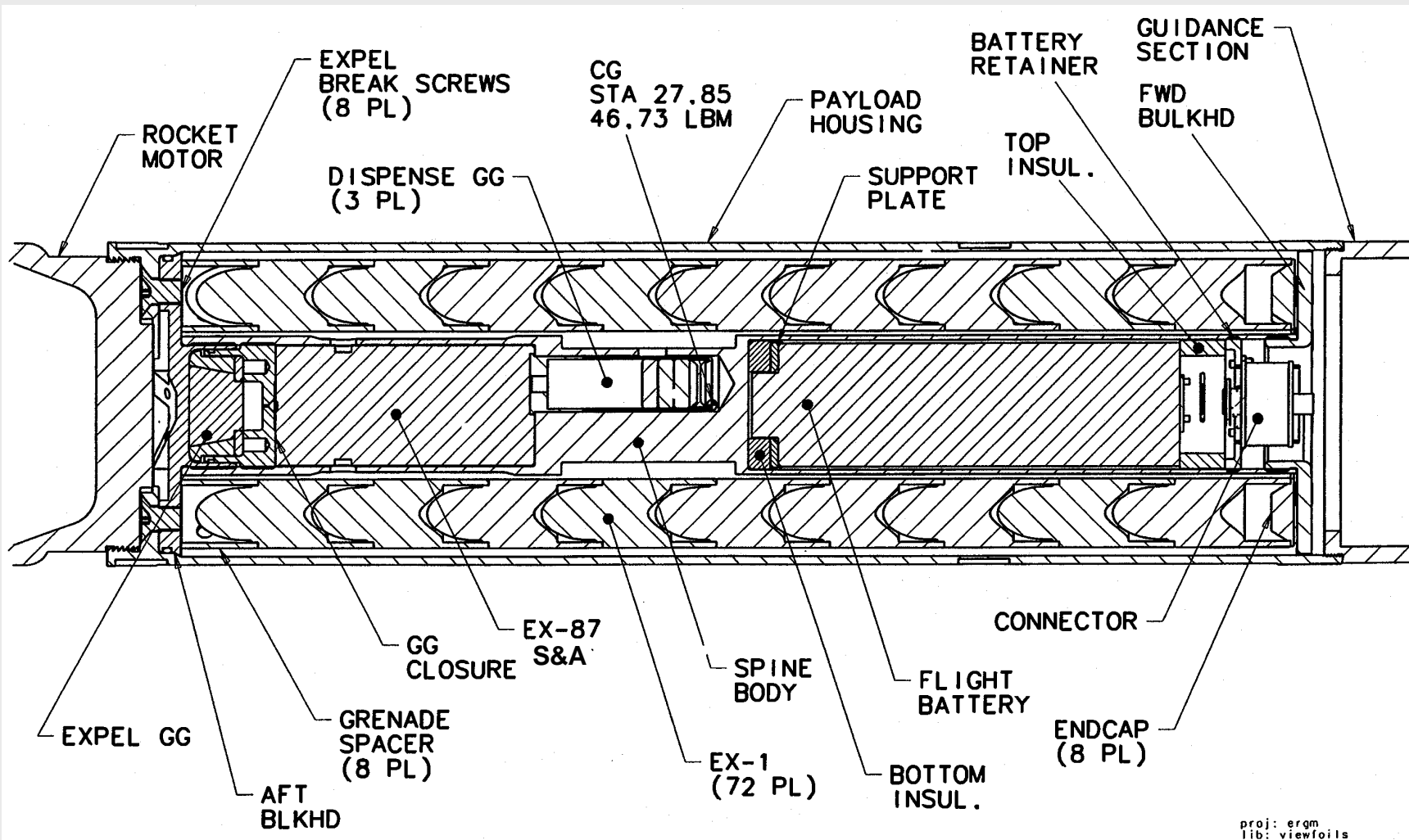

proj: ergm  
lib: viewfoils



# ERGM Fuzing Status

- ❑ **EX-87 Mod 1 S&A:**
  - **Completed Design Validation Tests (DVT)**
  - **Successfully Fired 3 in Canister Projectiles**
  - **Successful Fired in Dynamic Dispense Air Drop Test (DD-1)**
  - **Lessons Learned from DVT have been Incorporated**
- ❑ **Near Term Testing:**
  - **S&A Qualification (July 01)**
  - **Piston Actuator Component Qualification (June 01)**
  - **Dynamic Dispense Gun Fire (May 01)**
- ❑ **M234 E1 Self-Destruct Fuze:**



# ERGM Fuzing Status

## □ M234 E1 Self-Destruct Fuze:

- **DD-1 Test (YPG, 18 Aug 00)**
  - Slight Over-Test Condition (Expel/Dispense Altitude Too Low)
  - 13 Primary Mode Failures (82% Successfully Armed)
  - 0 ERGM Shunt Removal Failures (100% Successfully Armed)
  - 14 Spiral Flag Failures (81% Successfully Armed)
- **Additional Improvements Incorporated for Dynamic Dispense Gunfire Test (DD-2) Scheduled for early May '01**

# M80 PIP Objective

- ❑ To package the electronics and mechanical components of the Proximity Fuze in the shape and size of the current M234 SD Slider for the M80 Submunition for ERGM
  - One-for-One replacement of current Slider

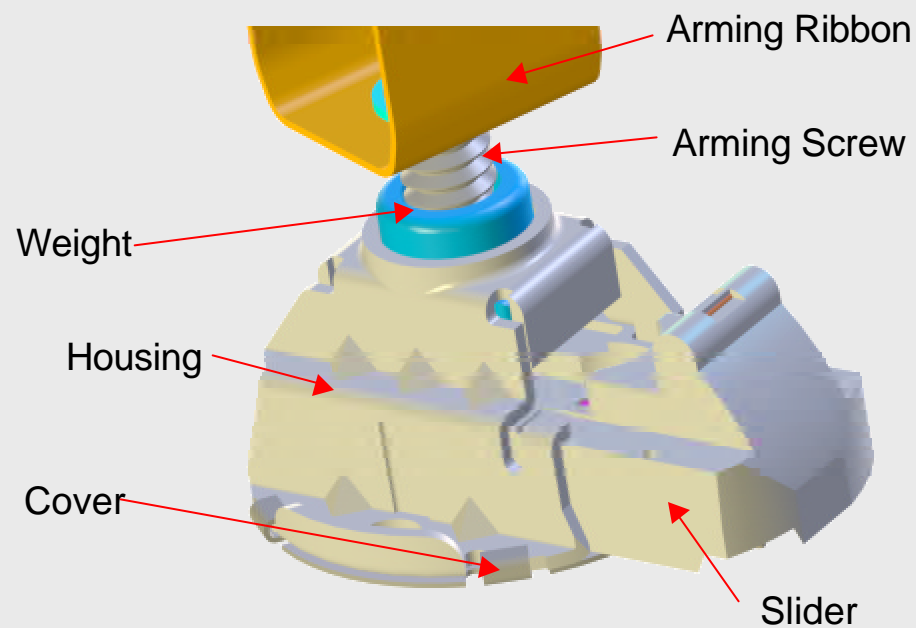
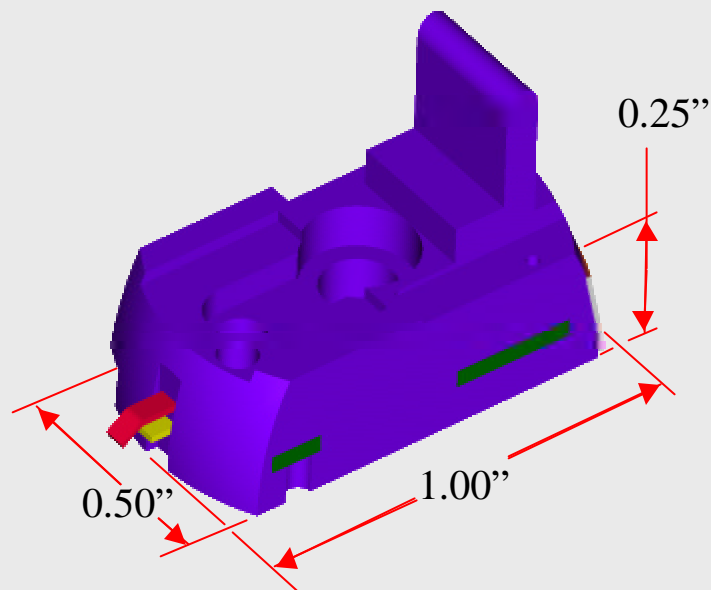



**MK 45 MOD 4**

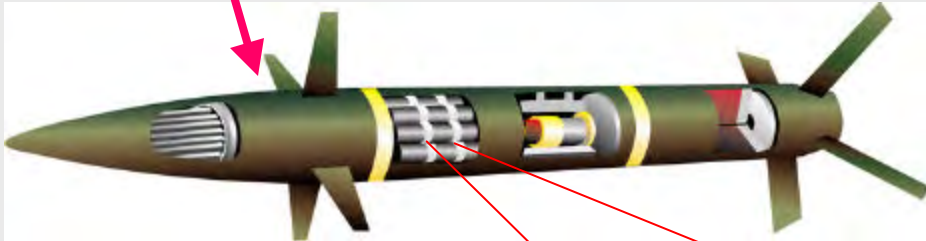

**ERGM**



**EX 3**

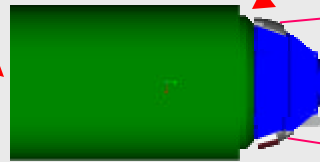

**Proximity Fuze**





# Major Component Layout

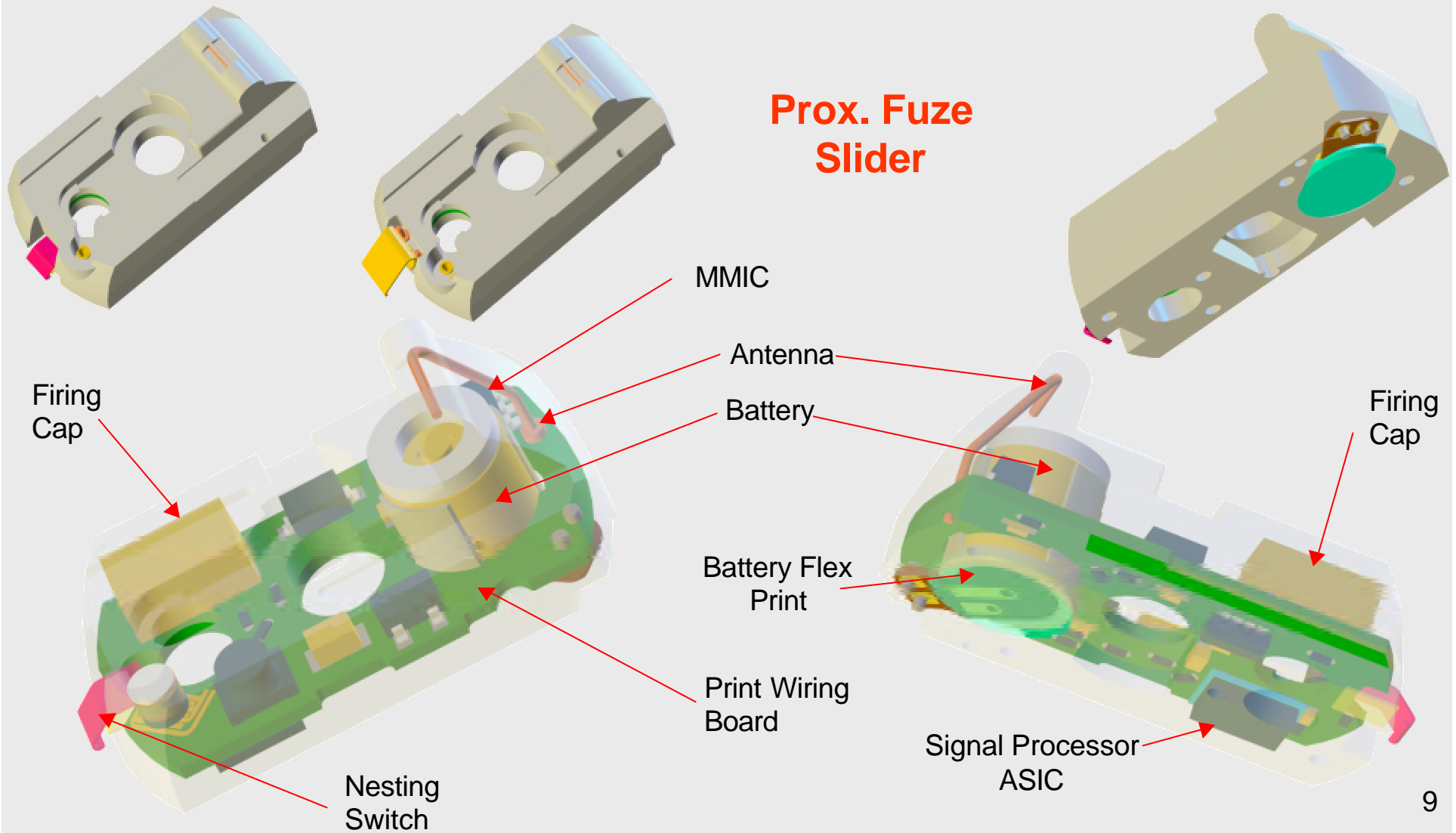

# Navy 5" Cargo Projectile

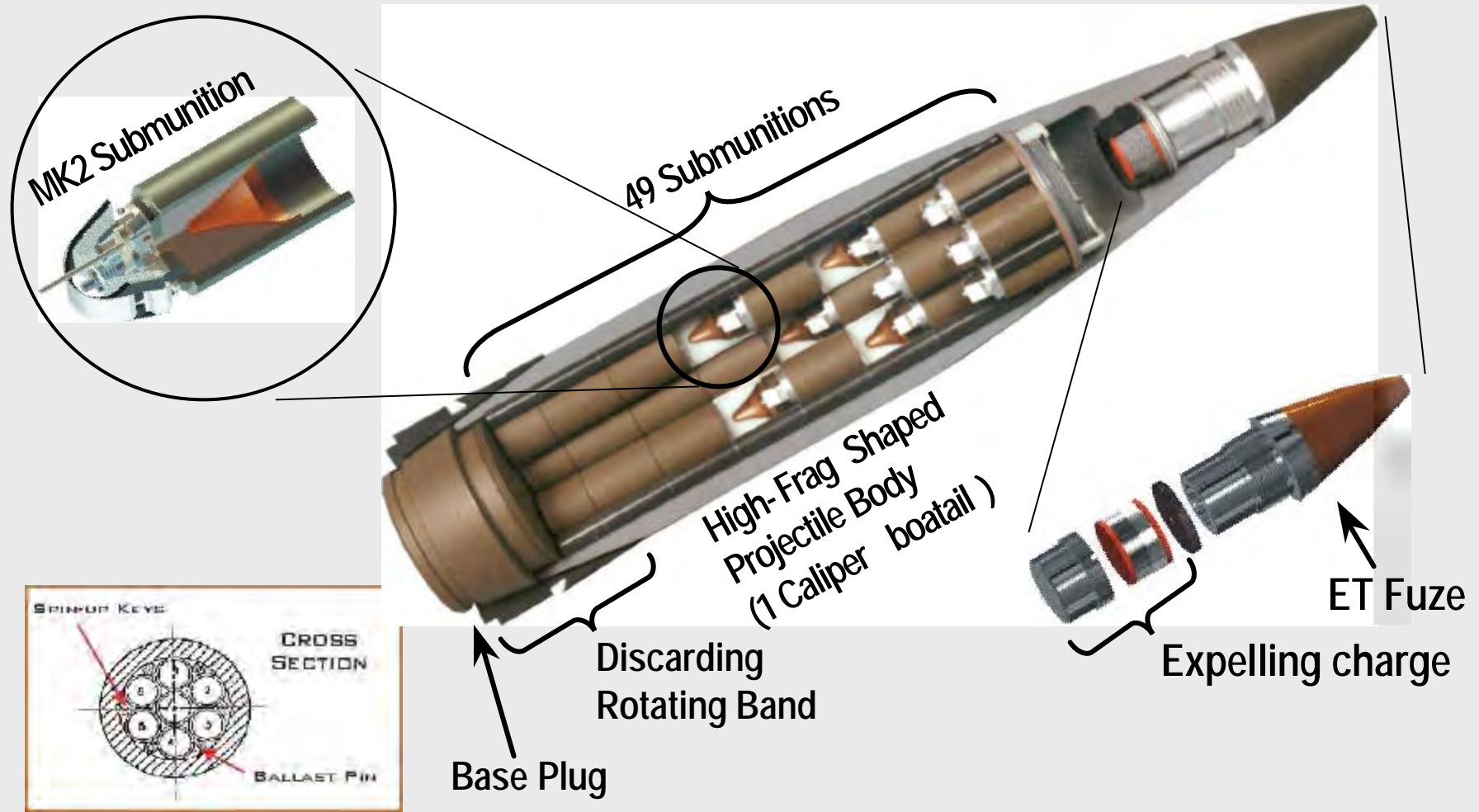



# M80 Grenade Fuze, M223 Safety Modification

## □ Design challenge:

- Add a safety feature to the grenade for the 5” cargo round
- Minimal cost and ASAP - we’re already in production: 700,000 fuzes made
- Requirements driven from WSESRB letter (objective) & PEO “acceptance of risk” (threshold)



# Resolution Efforts (Grenades already purchased)

Numerous add-on and redesign fixes were sketched and analyzed, then down selected a number of add-on fixes

### Slow Cook-off Simulated Magazine Set-up

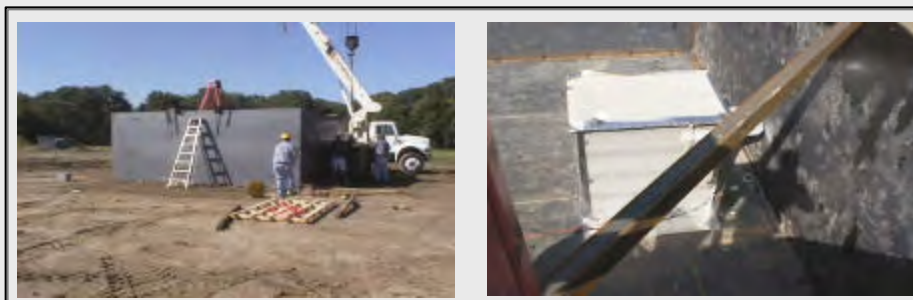

### Thermocoupled Grenades



### Shrink Tubing



**Program has invested over \$1.5M to date to resolve issue**

### Dayron Setback Clip



### Dayron Dual Mode Clip

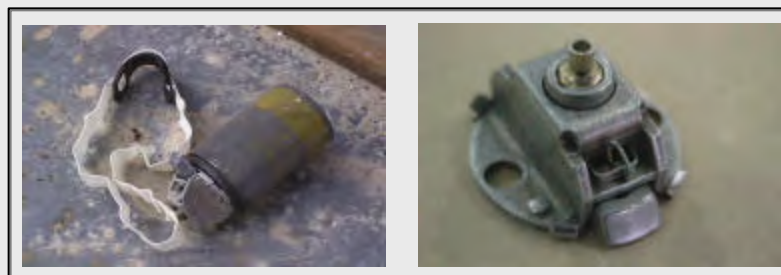

### Engineering Concept

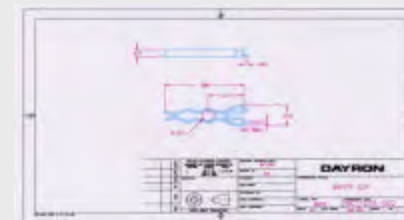

Metal spin clip line of designs stopped by WSESRB letter 12



# Resolution Efforts Downselect

**Dual  
Meltable  
Spin Locks**

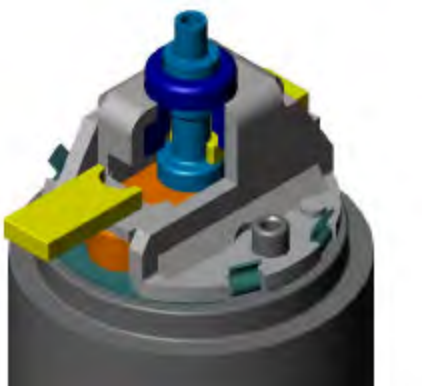

- ❑ 1st tests show both significantly improve safety
- ❑ Solutions will meet 95% of the WSESRB concerns. May still leave 1 armed grenade plus 2 w/o an extra lock post cook-off

**Single  
Meltable  
Spin Lock**



- ❑ Reliability testing and final downselect in May 01
- ❑ Cargo Program review at end of month. May change design course & require a 100% solution

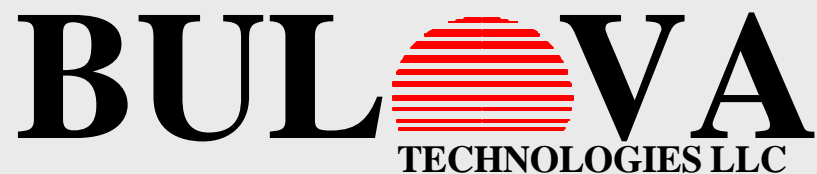

# MK 432 ELECTRONIC TIME FUZE

## *A New Fuze for the US Navy*

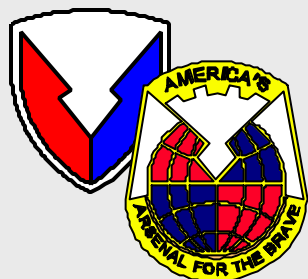



# Team Approach

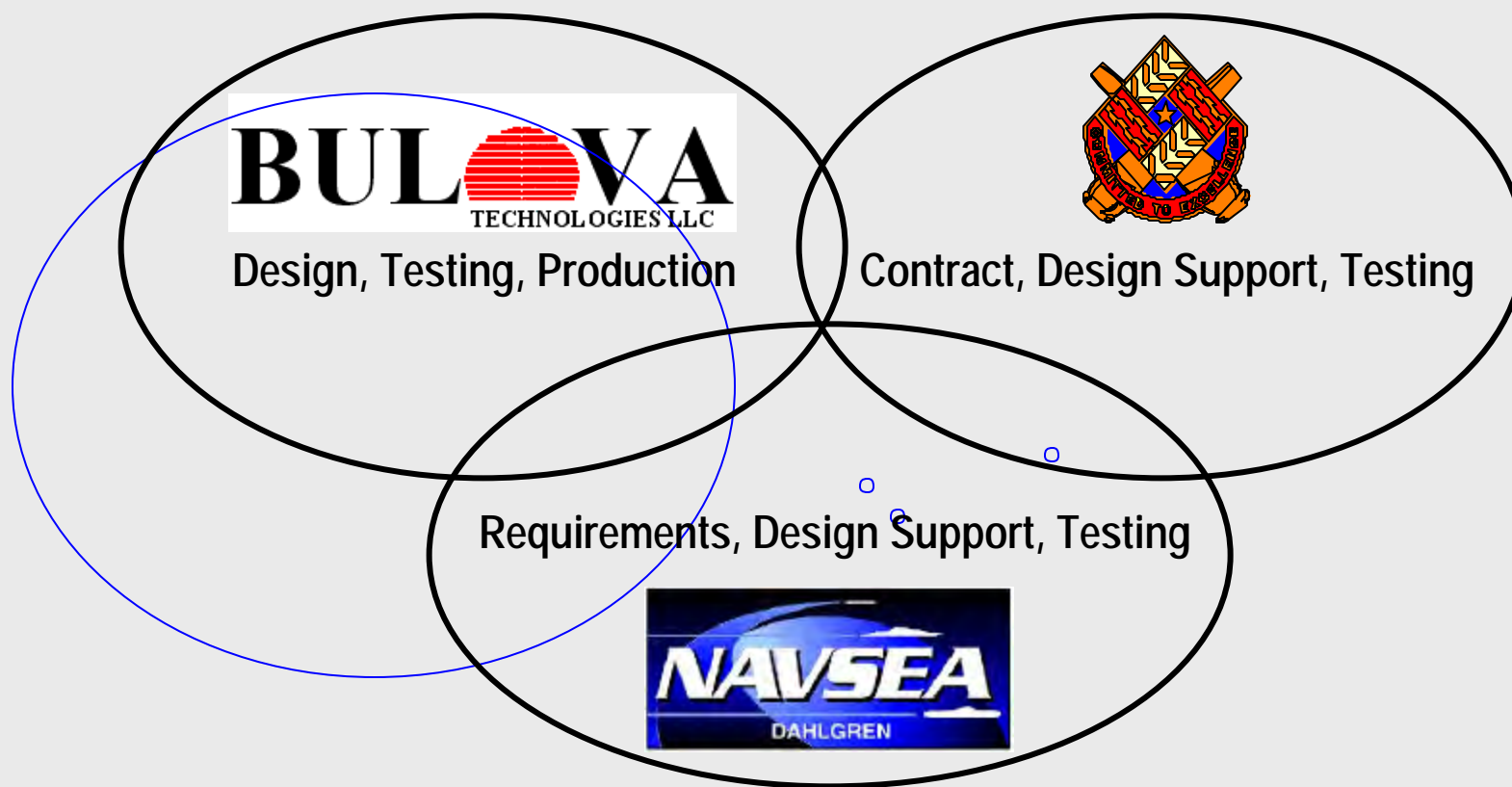



# Navalization of the M762A1

- ❑ **Inductive Set Compatibility**
- ❑ **Battery Activation**
- ❑ **Targets**
- ❑ **Remove PD back-up**
- ❑ **EEE improvements**
- ❑ **IM**



# Qualification

- ❑ **Completed in 9 months:**
  - 400 fuzes delivered
  - Successful gun firings
- ❑ **Qualification Completed Summer 2001**
- ❑ **Production Scheduled to begin July 2001**
- ❑ **14,600 Fuzes Delivered October 2001**

***Multi-function  
Fuze  
(MFF)***





# MFF Operational Modes

Air Proximity (AIR)

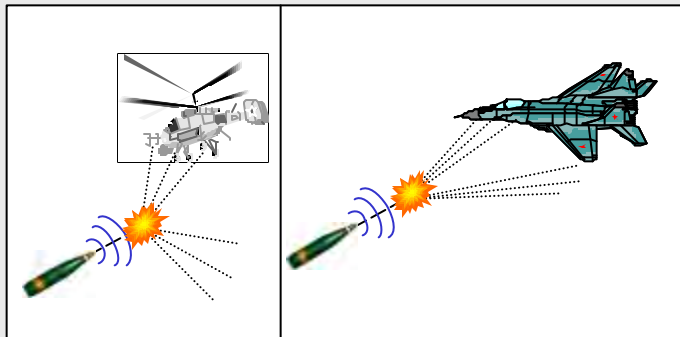

Point Detonating (PD)

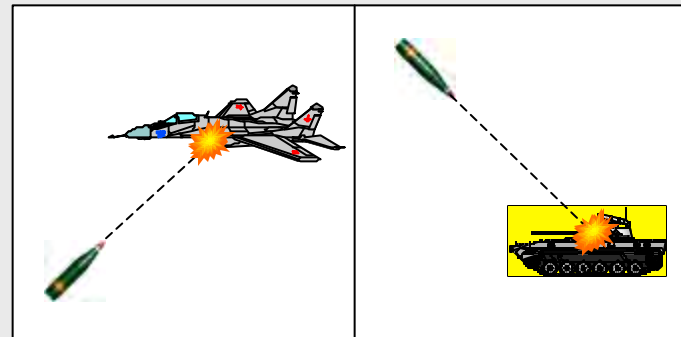

Surface Proximity (HOB)

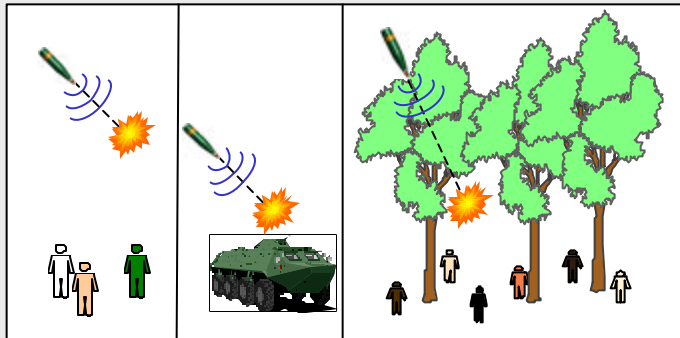

Electronic Time (ET)

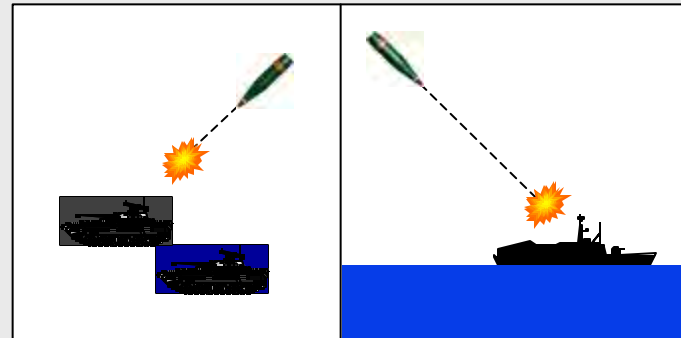

Autonomous (AUTO)

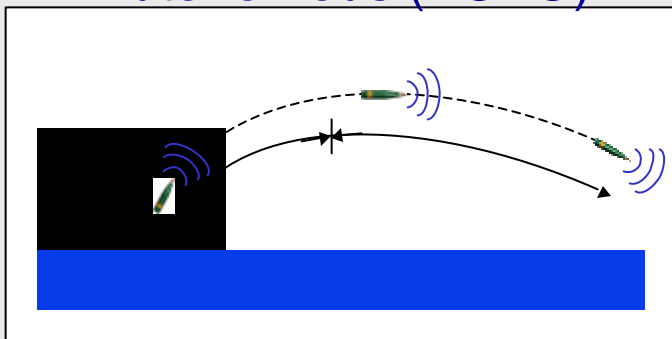

Replaces VT, CVT, MT & PD fuzes on HE rounds.  
Simplifies logistics.  
Uses IM Explosives.

Multiplies effectiveness of ship's magazine.  
Improves fuze performance, accuracy, reliability & versatility.



## MFF LRIP

- ❑ IPT: NSWC Dahlgren, NSWC Crane & ATK
  - Performance Specification
- ❑ Production at Alliant Precision Fuze Company, L.L.C in Janesville, WI
- ❑ LRIP ~9500 fuzes in 3 lots
- ❑ Options for another 6000 to 12000
- ❑ Pre-First Article performance
  - Twice as sensitive as MK 418 VT-RF fuze against the same air target
  - E&MD performance & production issues resolved



# MFF Schedule

- ❑ New Program Schedule Approved
- ❑ Updating the ORD and TEMP
- ❑ TECHEVAL 3rd Qtr FY01
- ❑ OPEVAL 4th Qtr FY01
- ❑ Milestone III Decision 1st Qtr FY02
- ❑ LRIP 1st Lot delivered 2nd Qtr FY02
- ❑ IOC 1st HE-MF rounds delivered 2nd Qtr FY02
- ❑ FOT&E for 5in/62 Gun Qualification in FY02





# MK 419 TECHEVAL

- ❑ San Clemente Island, SHOBA, 3rd Qtr FY01
- ❑ USS Bunker Hill (CG 52)
- ❑ 57 MK 419 Test rounds, 90 rounds total
- ❑ Part of First Article
- ❑ Test HOB, PD, ET, AUTO(HOB) performance over land and water





# MK 419 OPEVAL

- ❑ San Clemente Island, SHOBA, 4th Qtr FY01
- ❑ USS Bunker Hill (CG 52)
- ❑ 170 MK 419 Test rounds, 200+ rounds total
- ❑ Test AIR, HOB, PD, ET, AUTO(HOB),  
AUTO(AIR) performance over land and water
- ❑ Towed RF air target



# MFF Cost Reduction RF System



- ❑ MMIC Receiver
  - Plastic encapsulation vs. ceramic pkg
  - Adjust frequency to reduce tuning effort
  - Align with optimum antenna and transmitter frequencies
- ❑ MMIC Transmitter
  - Plastic encapsulation
  - Frequency tweak if required
- ❑ Antenna
  - Improve dielectric material properties to enhance producibility
  - Decrease raw material cost



# MFF Cost Reduction Battery

- ❑ Use MOFA battery with minimal modification
  - Failed to meet performance requirements
- ❑ European battery conference held to identify potential battery sources

# Technical Objectives

- ❑ Develop an alternative Low Cost Guidance Electronics Unit (LCGEU) for the EX171 Extended Range Guided Munition (ERGM)
  - design as a form, fit, & function replacement for existing ERGM GEU
  - identify & select performance trades versus affordability
  - demonstrate performance via a series of guided flight tests

*Form, Fit, Function GEU  
replacement for EX-171*



**LOW  
COST  
GEU**



# Technical Objectives (Contd)

- ❑ Prepare for transition to future EMD phase
  - Work closely with Rockwell / Collins (EMD prime) to develop cost as independent variable in LCGEU design
  - Deliver complete HW/ SW documentation package
  - Identify future production cost reduction opportunities

**LOW  
COST  
GEU**

*Form, Fit, Function GEU  
replacement for EX-171*



# Baseline Mechanical Design

**LOW  
COST  
GEU**

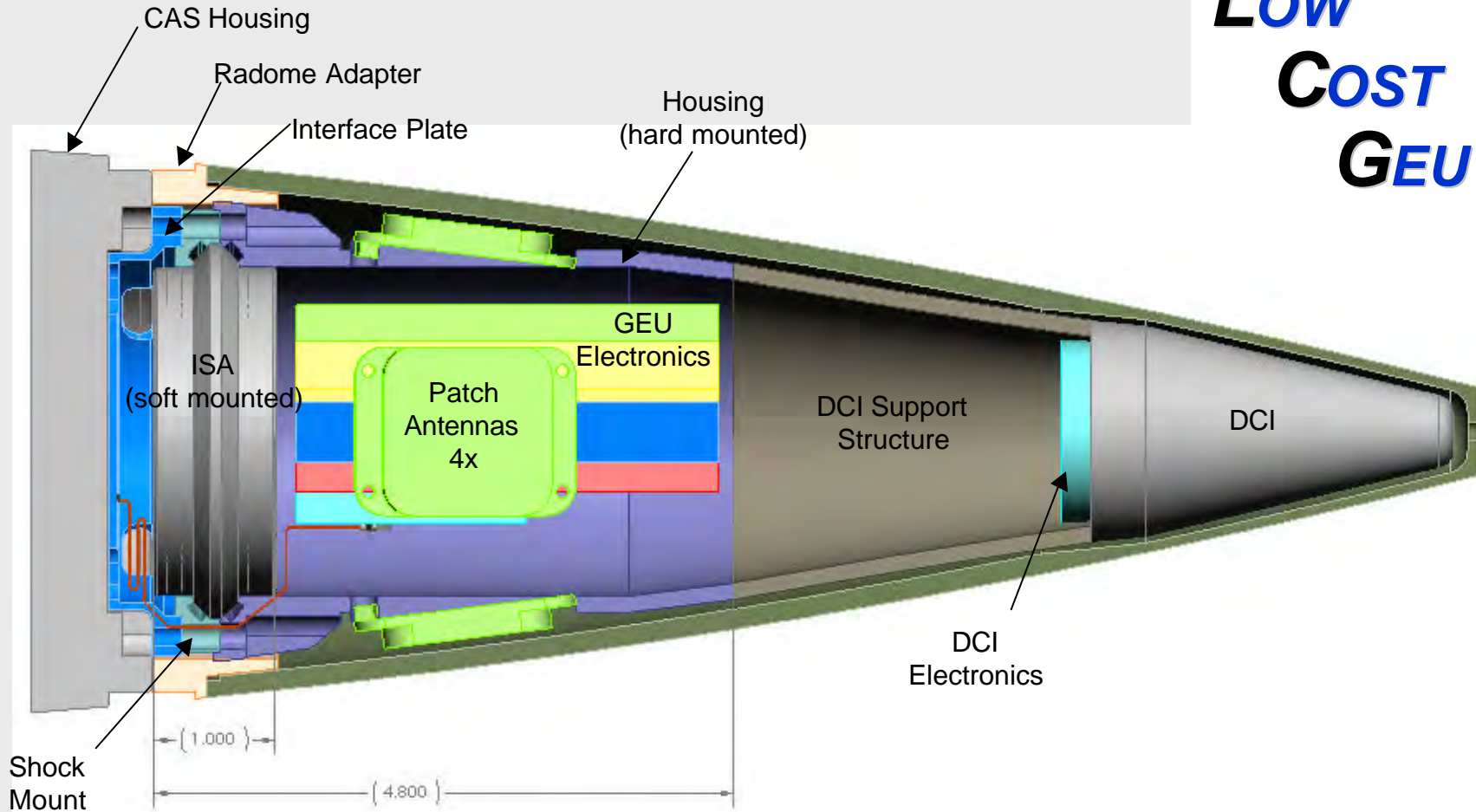



# Standard Missile - 4 Height of Burst Fuze

Integrated Product Team (IPT) Assembled to Select a Height of Burst (HOB) Sensor and Incorporate as Primary Fuze for LASM

**Raytheon**

- HOB IPT LEAD
- MISSILE DESIGNER



- TDA, REQUIREMENTS DEFINITION
- MODELING, TESTING



- GOVERNMENT FUZE EXPERT
- BAA

# Mission Overview

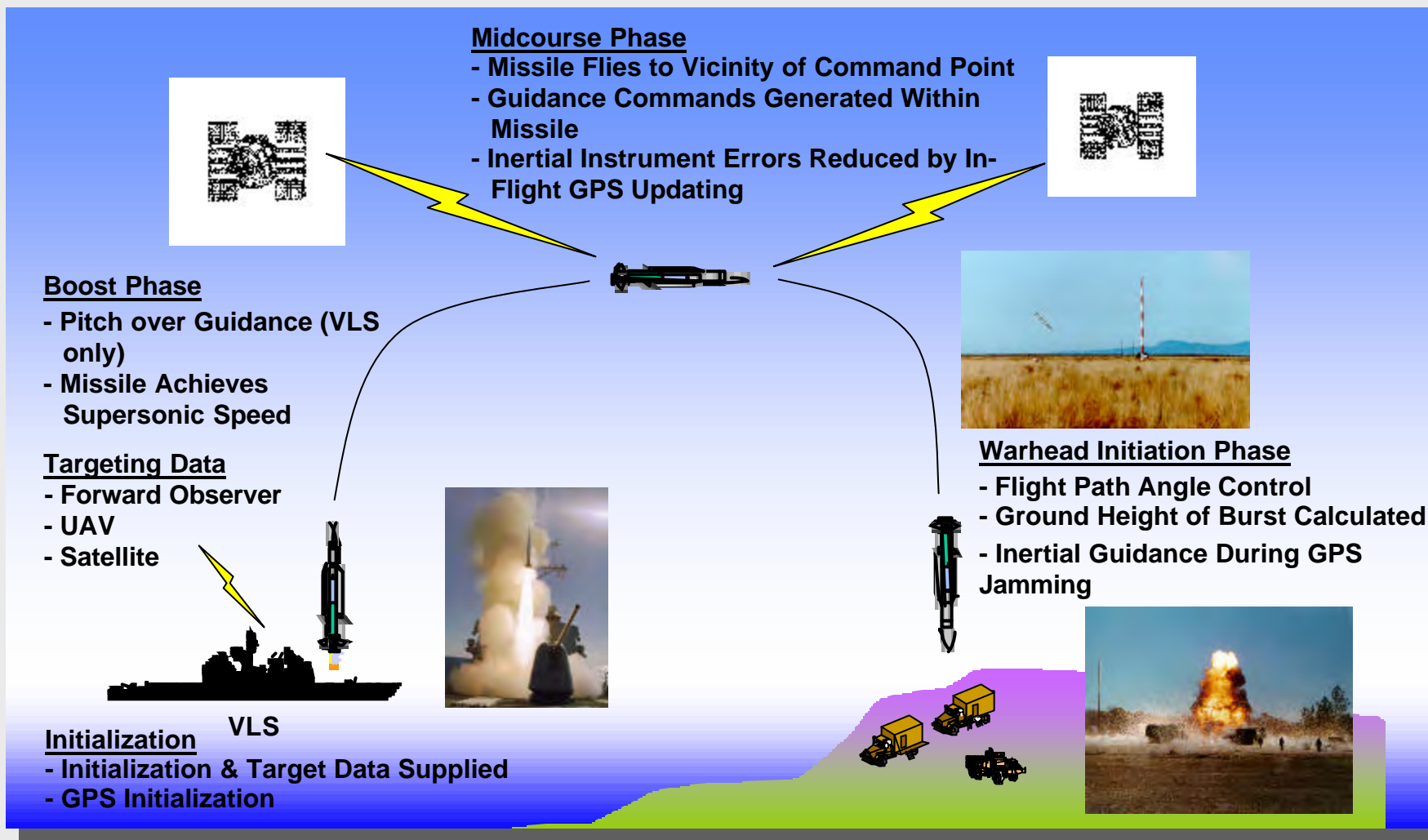



# HOB Sensor Selection

- ❑ **Identify Candidate Sensors**
  - Broad Agency Announcement (BAA)
  - Previous Trade Studies
  - Recommendations from Team Members
  - 18 Sensors from 12 Vendors Identified
- ❑ **Sensors Fell into 3 Classes: Radio Frequency, Electro-Optical, Mechanical**
- ❑ **Down-select to Set of Sensors Meeting Minimum Requirements**
- ❑ **Used Quality Functional Deployment Matrix for Comprehensive Comparison of Down-selected Sensors**
  - Evaluation Criteria Split Between Cost and Performance
  - Relative Weights of Evaluation Criteria Determined by Team Consensus
  - Scores Awarded Each Sensor Determined by Team Consensus

# HOB Sensor

- ❑ Gen III - LASM Configuration
- ❑ Near IR Pulsed Diode Laser
- ❑ Low Cost, Rugged, Low Power, Array Logic, Microprocessor w/ EEPROM flash Memory, Serial Communication, Continuous Altitude readout, Obscurant Algorithms

- ❑ Gen III - Performance
- ❑ Cost Effective
- ❑ Will Meet Missile Environments
- ❑ Meets Clear Air Requirements
- ❑ Will Not Pre-trigger on Obscurant
- ❑ Will Distinguish Hard Targets from Obscurants
  - Degradation of Performance in Obscurants - TBD
- ❑ Mechanically and Electrically Interface with GS
- ❑ Adaptive Configuration for Future Growth

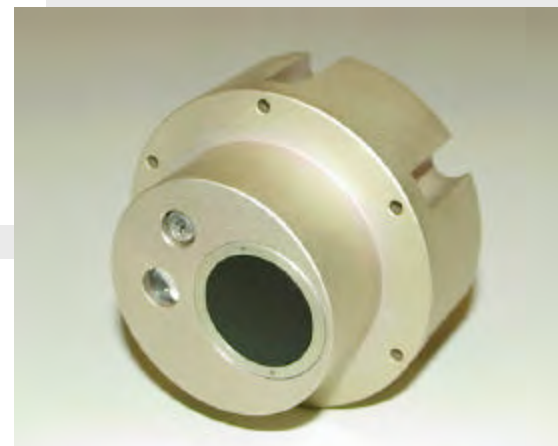

# GUIDANCE SECTION ASSEMBLY

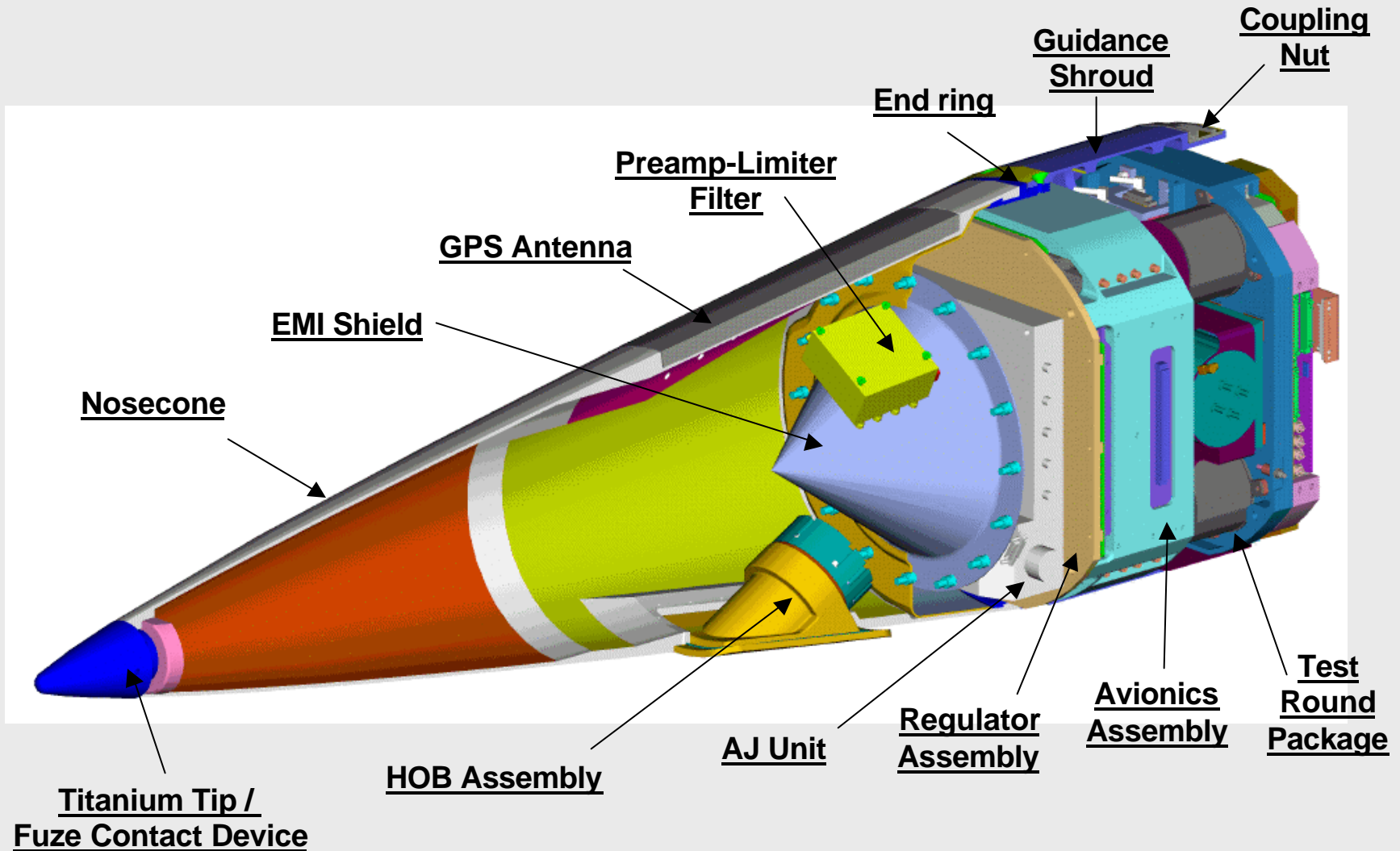



# Summary

- ❑ Requirements Defined
- ❑ EO Sensor Characterized and Risks Identified With Mitigation Plans
- ❑ Preliminary Mechanical Design for HOB Main Assembly Complete
- ❑ Analysis and Test Performed



## Future Efforts – Course Corrected Fuzes

- ❑ Trajectory error management
  - 1-D Corrections: drag chutes, drag fins, etc. to reduce range dispersion
  - 2-D Corrections: canards, pulse dots, etc. to reduce range dispersion and cross-track deflection
- ❑ Must not violate NATO standard fuze envelope during pre-flight
  - Ensures minimal impact on round handling equipment and procedures
  - MIL-STD-333B envelope selected
- ❑ Range increase not required
- ❑ Fielding by FY10



# Future Efforts – Low Cost Projectile Fuze Alternatives

- Reduce Fuze Re-procurement Costs
  - Buy Fuzes with Army
    - Navalized MOFA
  - Buy Components with Army
    - Common S&A, battery, detonators
  - New Fuze
    - Low Cost Air Warfare Fuze
  - New Requirements



# Issue #1: Batteries

- ❑ In the last few years, DOD has lost significant manufacturing and design ability to make batteries for gun fired munitions
  - Reduction in the last 10-15 years
    - Govt battery R&D personnel: approx 90% loss
    - Contractor companies: from 15 to 3
- ❑ The government has not maintained the expertise
- ❑ The contractors can not maintain the expertise
- ❑ No fundamental R&D conducted in the last 10 years in liquid reserve technology
- ❑ Applied chemical engineering has been conducted in a limited way on select programs with very limited success
  - Based on 15-20 year old technology



# Impact to Navy Programs

- ❑ JMPSIB-IPT
  - Dahlgren is the Navy's lead on the Joint Service IPT
- ❑ MK 419 MFF Battery
  - MK 44 Lead-chemistry battery unproducible within USA
  - No direct replacement
    - Lithium replacement program did not meet requirements
    - Investigating two European batteries
      - Lithium Chemistry
      - Lead Chemistry



# Miniature Liquid RE

- ❑ EP, ATK, KDI have no success or limited experience in the cutting edge of power sources technology
- ❑ Major concern to ERGM program for both submunition programs
  - M234 SDF
  - EX 433 Prox Fuze



# Objectives

## ❑ Current Navy Projectile Battery Requirements

- ERGM
  - 2 System batteries (1 thermal reserve, 1 liquid reserve)
  - 72 Submunition batteries
- MK 419 - MFF
- MK 418/MK 417 - VT-RF
- MK 404 - VT-IR
- EX 432 - ET

## ❑ Future Naval Gun launched projectiles requiring a power source

- GPS Rounds
- Best Buy - GPS, 100nmi
- Badger - GPS, Hypersonic projectile
- MRO Mission Responsive Ordnance
- AGS munitions



## Issue #2: Submunitions

**"On April 24, five children playing with colorful unexploded submunitions were reported killed, and two injured, near Doganovic in southern Kosovo."**

-Steve Goose, program director of Human Rights Watch's arms division as reported in the Washington Post, Saturday, June 19, 1999; Page A19

**"PRISTINA, Kosovo, May 22 -- One boy was killed and two other children were seriously wounded by a cluster bomb on Sunday..."**

-Carlotta Gall; published on Tuesday, May 23, 2000 in the New York Times

**"Submunition weapons employment in Southwest Asia and Kosovo, and major theater war modeling, have revealed a significant unexploded ordnance (UXO) concern."**

-William Cohen, former U.S. Secretary of Defense in a memorandum dated 10 January, 2001





# SecDef Memorandum

- ❑ “It is the policy of the DoD to reduce overall UXO...
- ❑ “...the desire is to field future submunitions with a 99% or higher functioning rate.”
- ❑ “Submunition functioning rates may be lower under operational conditions...”
- ❑ “Services may retain ‘legacy’ submunitions...”
- ❑ “Waivers to this policy...shall require approval by the JROC.”



# Navy Programs Affected

- ❑ ERGM
- ❑ Cargo
- ❑ MRO
- ❑ MLRS (Marine Corps)

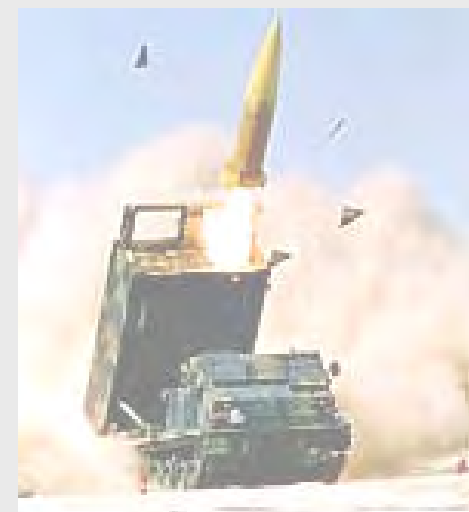
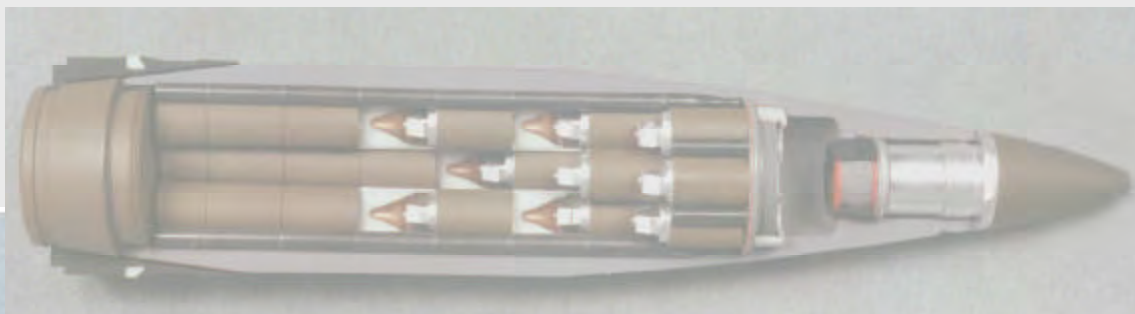

# What's Next?

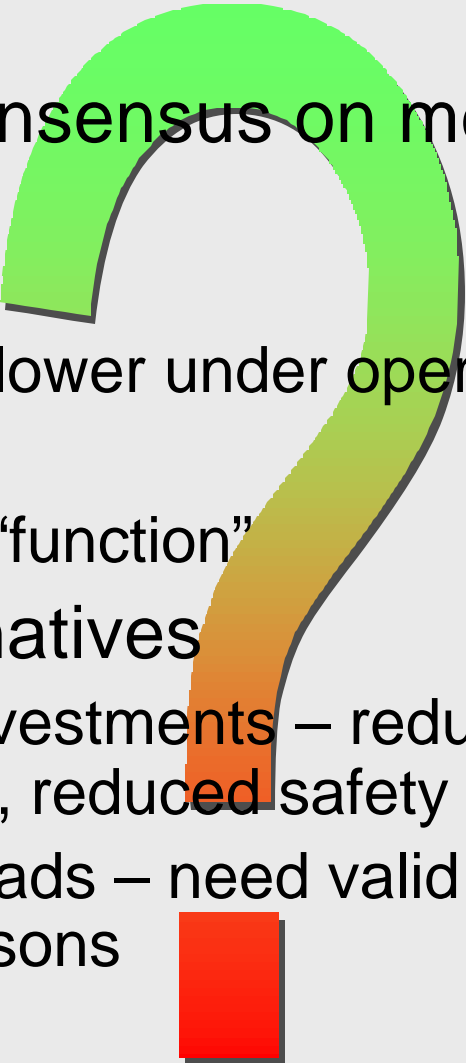
- 
- ❑ Community Consensus on meaning of memorandum
    - “function”
    - “rates may be lower under operational conditions”
    - “waivers”
    - Safe UXO vs. “function”
  - ❑ Evaluate Alternatives
    - Technology Investments – redundancy, miniaturization, reduced safety
    - Unitary Warheads – need valid lethality models to make comparisons



# ***NDIA FUZE CONFERENCE***



## **Fuzes for Air Force Unguided and Precision Guided Weapons**

**17 April 01**

***Air Armament Center***  
**AAC/WMG**  
**Eglin AFB, Florida**

**Mr. Frank Robbins**  
**Director**  
**Precision Strike SPO**



# **OUTLINE**

---



- **Current Weapon Systems**
- **Fuzes: Inventory, Production**
- **Challenges For Today's and Tomorrow's Fuze Programs**



# ***CURRENT WEAPON SYSTEMS***

---



- **AGM-130**
- **AGM-142**
- **GBU/EGBU-15**
- **GBU/EGBU-24/27**
- **GBU/EGBU-28**
- **JDAM**
- **JASSM**



# AGM-130 MISSILE SYSTEM DESCRIPTION



- **Rocket Powered Standoff Precision Guided Missile**
  - **Man-in-the-Loop (MITL) Terminal Control**
  - **Interchangeable TV or IR Seekers**
  - **Interchangeable MK 84 or BLU-109 Penetrator Warhead**
  - **Fully Autonomous INS/GPS Adverse Weather Capability**
- **Only U. S. Fighter Launched Air Force Standoff Weapon With 2,000 Pound Warhead**
- **Integrated on the F-15E Strike Eagle**
- **Over 100 Used During Operations NORTHERN WATCH SOUTHERN WATCH and ALLIED FORCE**



# **AGM-130 EXPANDED EFFECTIVENESS**



- **Weapon Improvements**
  - **Television Guidance Seeker (CCD)**
    - **Charge Coupled Device**
    - **Rate Stabilized Platform**
    - **Correlation Tracker**
  - **Improved Modular IIR Seeker**
    - **Focal Plane Array**
    - **Correlation Tracker**
  - **Digital Autopilot With GPS/INS**
  - **Switchable Data Link**
  - **Performance Enhancements**
    - **Horizontal Target Attack**
    - **Envelope Expansion**
    - **Real Time Information in the Cockpit**
  - **Support Equipment Improvements**



# AGM-142 MISSILE SYSTEM DESCRIPTION



- **Precision Guided, Standoff Weapon for Use Against High-Value/ Heavily Defended Fixed Targets**
  - Data Link Pod Augments Inertial Navigation
  - Interchangeable TV, IIR, or Z-Seeker
  - Interchangeable 750 Lb. Blast/Frag or 800 Lb. Penetrator Warheads
- **Only U.S. Bomber Launched Precision Weapon System**
- **Weapon of Choice for Multiple Allied Fighter Aircraft**



# **GBU-15 MISSILE SYSTEM DESCRIPTION**

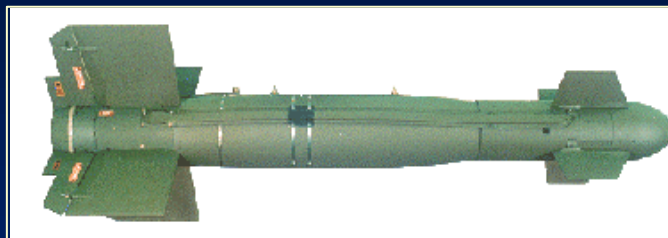

- **Standoff Precision Guided Weapon System For Use Against High-Value Fixed Targets**
  - **Man-in-the-Loop (MITL) Terminal Control**
  - **Interchangeable TV or IIR seeker**
  - **Interchangeable MK 84 or BLU-109 Penetrator Warhead**
- **Integrated on the F-15E Strike Eagle**



# ***EGBU-15 DESCRIPTION***



- **Platform - F-15E**
- **Warheads - MK-84/BLU-109**
- **Seekers - TV or IIR**
- **Guidance - Autonomous GPS/INS, Man-in-the-Loop**
- **Data Link - AXQ-14, ZSW-1**



# ***EGBU-15 PROGRAM BACKGROUND***

---

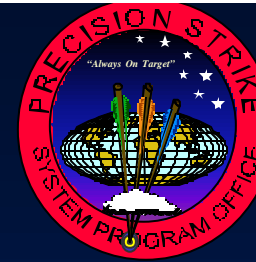

- **Chief of Staff, Air Force Directed Quick Reaction Capability Program to Provide Adverse Weather Enhancement to Legacy GBU-15 Weapon System**

- **Based upon “Urgent and Compelling Combat Need”**
- **Balkans Conflict Depleted Inventory of Precision, Standoff Weapons**

- **Two-Phased Approach**

- **Phase I Program**

- **Design, Test, Produce, and Field 100 weapons in 45 days**
- **Provide “Interim” integration**

- **Phase II Program**

- **Design, Test, Produce, and Field 1200 weapons in 12 months**
- **Provide “Complete integration”**



# ***EGBU-15 STATUS***

---



- **Phase I Deliveries Complete; 50 Weapons Delivered in 44 Days; 100 Total Weapons Delivered in 69 Days**
- **Phase II Deliveries Complete; 1200 Weapons Delivered in 12 Months**
  - **5 Development Test and 6 Operational Test Drops -- 11 direct hits!**
  - **Field Modifications Efforts Completed at Many Locations Worldwide**
  - **Final Advance Support Equipment, Mission Planning System, and Mission Squadron Trainer Upgrades Nearing Completion**
  - **Operational Training Completed at Most Operational bases Worldwide**



# LASER GUIDED WEAPONS





# **GBU/EGBU-24/27 MISSILE SYSTEM DESCRIPTION**



- **Laser Guided Munition Designed for Horizontal and Vertical, Hardened and Deeply Buried Targets**
  - Laser Designator (Aircraft or Ground)
  - Laser Guided MK 84 or BLU-109A/B 2000 Lb. Warhead
- **Used on Heavily Reinforce Concrete Bunkers, SAM Sites, Etc...**
- **Integrated on the F-117, F-15, F-16, Navy F-14 & F-18**
- **Improvement Program**
  - **Autonomous INS/GPS Laser Guided Provides Adverse Weather Capability**



# **GBU/EGBU-28 MISSILE SYSTEM DESCRIPTION**

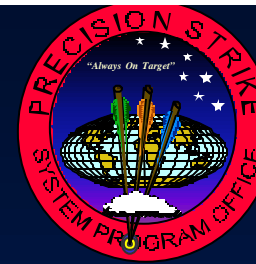

- **Laser Guided Munition Designed for Super Hardened and Deeply Buried Targets**
  - Laser Designator (Aircraft or Ground)
  - WGU 36A/B Laser Guidance Unit
  - BLU-113A/B Penetrator Warhead (5000 LB)
- **Developed in 34 days during Operation DESERT STORM**
- **Integrated on the F-15E Strike Eagle**
  - On Going Integration on the B-2
- **Improvement Program**
  - Examining Improved Penetration
  - Autonomous INS/GPS Adverse Weather Capability
  - Hard Target Smart Fuze



# Joint Direct Attack Munition (JDAM) System Description

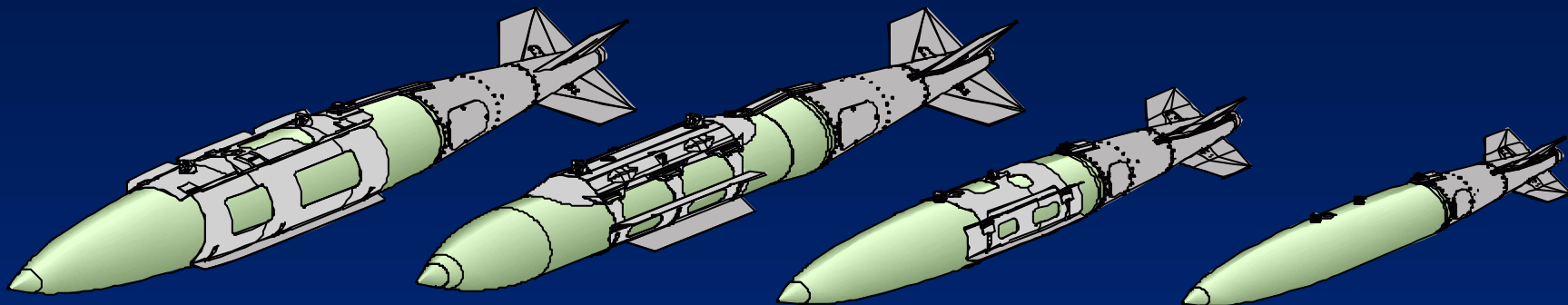

Mk-84

BLU-109

Mk-83, BLU-110

Mk-82

- Joint Air Force/navy Program to Develop Affordable, Adverse Weather, & Accurate Guidance Kit for 1000 and 2000 Pound Bombs... Eliminate Higher Cost, Limited Utility Interim Weapons
- INS/GPS Guidance Kit Attached to the Bomb Using Controlled Tail Fin Movements to Direct Bomb to Target
- Fuzes: FMU-139, FMU-143, FMU-152 & DSU-33
- Allows US Forces Precision Engagement in All Flyable Weather
- Lethal...Multiple Kills Per Pass + Fire and Forget
- Interoperable...Bmbers, Fighters, Carrier, Bare Base
  - B-2, B-52, B-1, FA-18, AV-8B, F-22, F-117, F-16, F-15, JSF
- Affordable - Extremely High Capability to Cost Ratio



# **BLAST FRAGMENTATION/PENETRATOR COMBINED/DESIGNS**



- **AGM-158 Joint Air-to-Surface Standoff Munition (JASSM)**
- **A Joint Air Force and Navy Program to Provide an Autonomous, Medium Range, Conventional, Air-to-Surface, Precision Missile Able to Strike High Defended, High Value Targets**
  - **WDU-42/B (1000 Lb..) Warhead Provides Penetration, Blast & Fragmentation Kill Mechanism Against all Designated JASSM Targets**
  - **INS/GPS Mid-Course Guidance**
  - **I2R Seeker**
  - **Adverse Weather Capability**
  - **Fuze: FMU-156**
- **For Integration on F-16, B-52, B-1B, B-2, F/A-18**
- **15 Year Bumper-to-Bumper Warranty**



# FUZE/WEAPON COMPATIBILITY



Weapon System	FMU 143	FMU 124	FMU 152	JUF	DSU 33	FMU 159	FMU 139	FMU 156	MEHTF	MAFIS	FMU 155
Mk 80 Series			X		X		X		O		
BLU-109/113	X		X			X			O		
JDAM	X		X		X	O	X		O		
GBU-15/AGM-130	X	X	X								
GBU-24/27	X		X			X	X		O		
JASSM								X			
GBU-28/37	X		X			X			O		
AGM-142	X	X									
AGM-86D						X					
SDB			TBD			TBD			TBD		
AUP						X					
TTPV						X					
JSOW Unitary				X						X	
SLAM/SLAM ER											X



# FUZES/SENSORS SCHEDULE HISTORY

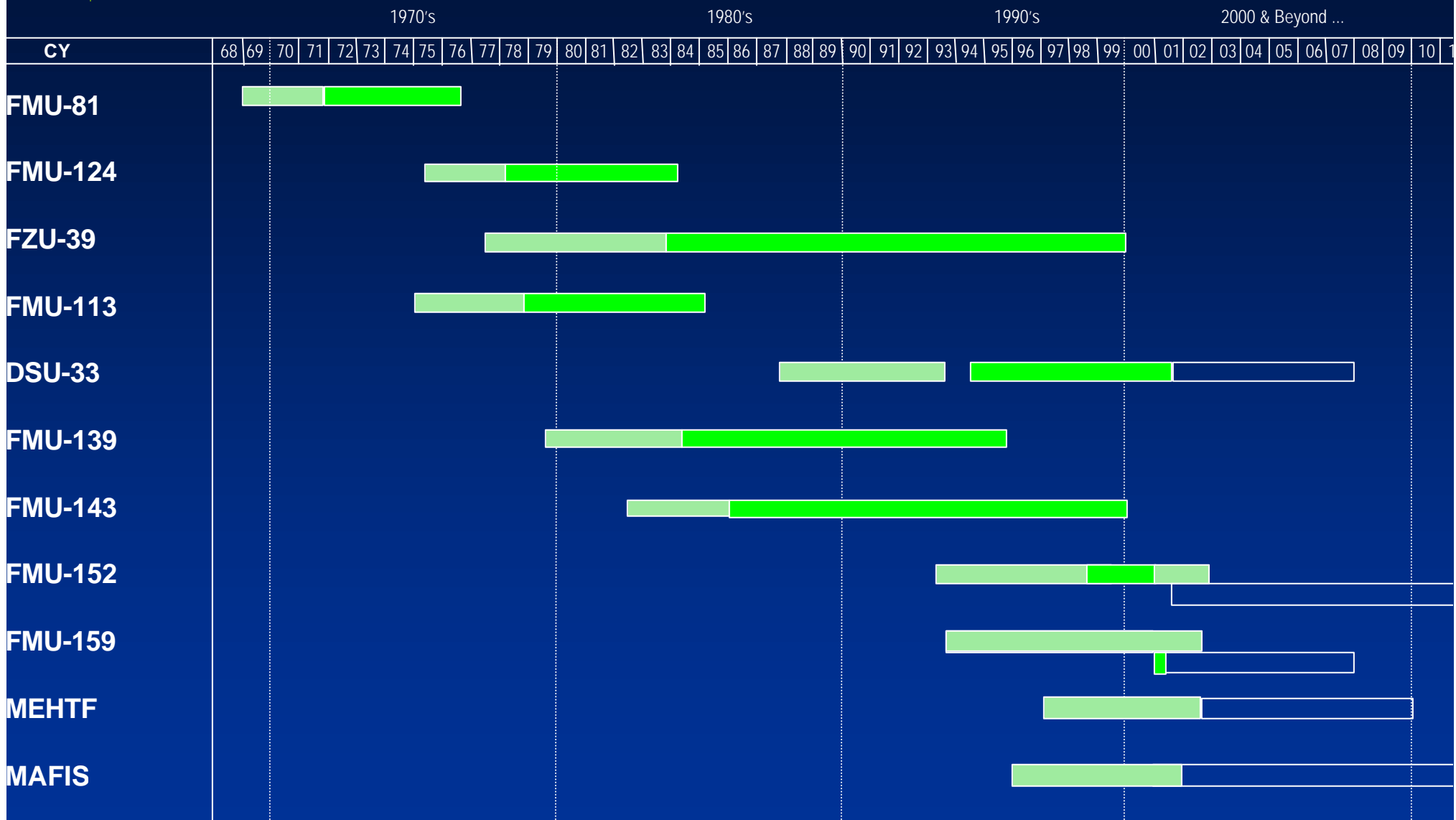

Development

Production



**Inventory Fuzes**



**Production/EMD Fuzes**



# USAF FUZE INVENTORY UNGUIDED CLUSTERS



Status March 2001

<u>Function</u>	<u>Type</u>	<u>Quantity</u>	<u>Weapon</u>	<u>Remarks</u>
Time	MK-339	81K	M129E1	Leaflets
Time or Proximity	TMD Fuze/ FZU-39	132K	CBU-87/ 89/97	



# USAF FUZE INVENTORY GUIDED BOMBS



Status as of March 2001

<u>Function</u>	<u>Type</u>	<u>Quantity</u>	<u>Weapon</u>	<u>Remarks</u>
Impact or Impact Delay (Optional)	FMU-81/B	37K	GBU-10/12 (LGB) MK-82, MK-84	
	FMU-124	2.5K	GBU-15, AGM-130, AGM-142, MK-84	
	FMU-139A/B	244K	GBU-24, AGM-65	Replaces FMU-81/B
	FMU-143 B/B	11K	GBU-10/24/27, GBU-15, AGM-130, AGM-142, BLU-109/B	
	FMU-143 F/B, G/B H/B	112 157 73	GBU-28	



# FUZE INVENTORY GENERAL PURPOSE BOMBS



Status as of March 2000

<u>Function</u>	<u>Type</u>	<u>Quantity</u>	<u>Weapon</u>	<u>Remarks</u>
Time	M-904	824K	No Hi Drag	
	M-905	1.1M	No Hi Drag	
	FMU-54A/B	24K	No Hi Drag	
	FMU-54/B	8K		
	FMU-139 A/B	244K		
Proximity	FMU-113	34.6K	No Hi Drag	
	DSU-33A/B	5010		
	DSU-33B/B	2447		(5635 in transit/Prod)



# FMU-139B/B FUZE PRODUCT DESCRIPTION



- Electronic impact/impact-delay fuzing system designed for use with general purpose high-explosive bombs
- Delivered with FZU-48/B initiator, power cable (attached) and closure ring
- Provides multiple fuzing options for:
  - Tail fuzing only
  - Nose fuzing only, and
  - Nose and tail fuzing

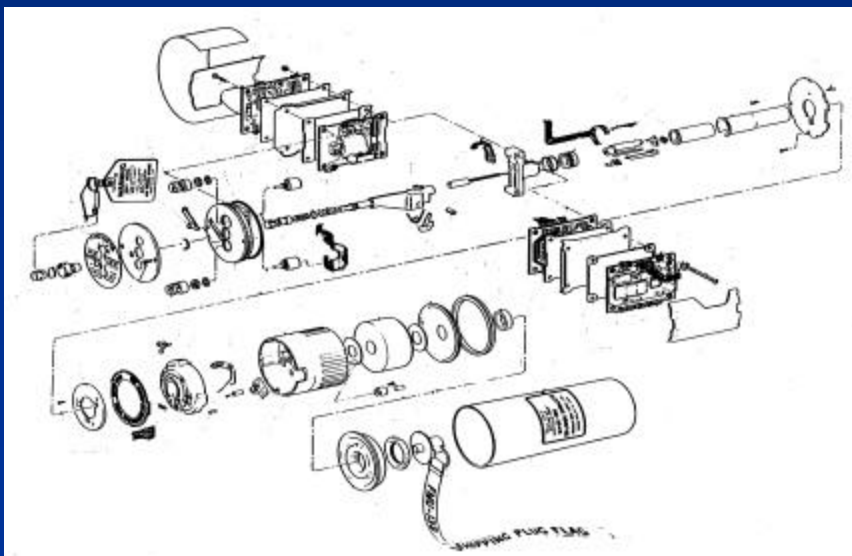



# FMU-139B/B FUZE



- **FMU-139B/B fuze is interoperable with all FMU-139A/B applications**
- **Compatible with laser guided bombs and with low and high speed drag air foil groups**
- **Compatible with DSU-33A/B and DSU-33B/B proximity sensor**
- **FMU-139 currently in use with MK80 series Joint Direct Attack Munition (JDAM)**
- **Being Replaced by FMU-152 Joint Programmable Fuze**



# FMU-143 A-H/B FUZE DESCRIPTION



- Impact Delay Fuze for Penetrating Warheads (Single 0.060 Sec. Delay)
- Interface - BLU-109, BLU-113, AGM-142 I-800
- Power/safety - FZU-32B/B Bomb Fuze Initiator, GBU-15/AGM-130 Battery
- Used On -GBU-10, 24, 27, 28, 31, AGM-142, and AGM-130, (With BLU-109 or BLU-113 Warheads)
- Being Replaced By FMU-152, JPF
- Manufacturer - Dayron Inc., Orlando FL.





# FMU-143 A-H/B FUZE SYSTEM



<u>Configuration</u>	<u>User</u>	<u>Modification</u>
FMU-143B/B and FMU-143B(D-2)/B	AF, FMS, JDAM	Basic - 60ms Delay, 5.5 or 12 sec Arm Time
FMU-143D/B and FMU-143D(D-2)/B	AGM-142	21 Sec Arm Time
FMU-143E/B and FMU-143(D-1)/B	Navy	PBXN-7 Booster/Lead
FMU-143F/B	GBU-28	30ms Delay/21 Sec Arm
FMU-143G/B	GBU-28	60ms Delay Same
FMU-143H/B	GBU-28	120ms Delay Same



# ADVANCED FUZES AND SENSORS



## Joint Programmable Fuze

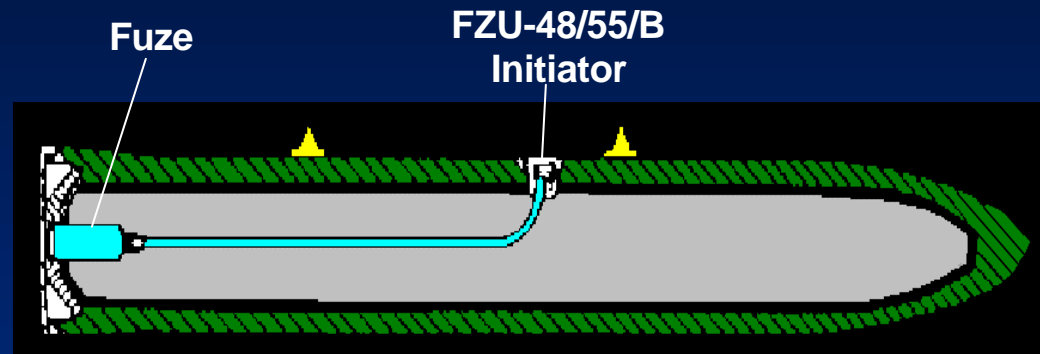

## Hard Target Smart Fuze

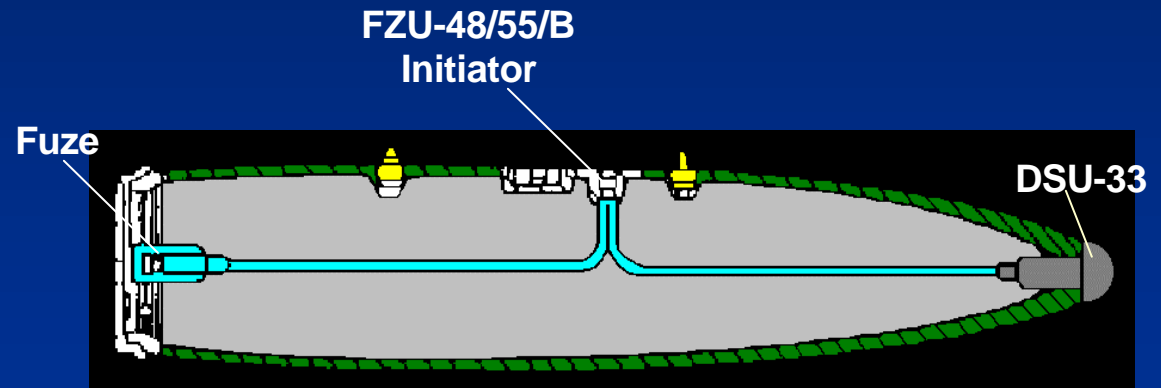

## DSU-33B/B Proximity Sensor



# JOINT PROGRAMMABLE FUZE (JPF)



**FMU-152/B**



# **FMU-152/B JPF SYSTEM DESCRIPTION**

---

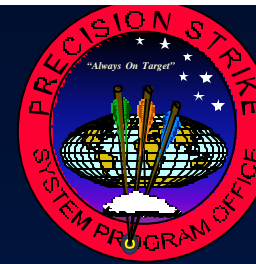

- **Single Fuze Compatible With Mk82, Mk83, Mk 84, BLU-109, BLU-113 for Use in AGM-130, GBU-10/12/15/16/24/27/28 and All JDAM Variants**
- **Can Be Used in Current FMU-139 and FMU-143 Applications**
- **Cockpit Selectable Arm/delay Times**
  - **Instantaneous to 24 Hours**
- **Multi-function Capability**
  - **Hard Target Penetrator Weapons**
  - **Blast Fragmentation**
  - **Backward Compatibility With Current Weapons**



# FMU-152/B JPF REQUIREMENTS



## Performance

Weapon Interface

Warhead Interface

Low Drag Arm Time (Sec)

High Drag Arm Time (Sec)

Impact Delay Times

Reliability

Service Life

Shelf Life

## Threshold Parameters

AGM-130, GBU-10/12/15/16/24/27/28, JDAM

MK-82/83/84, BLU-109/113

4.0, 4.5, 5.0, 5.5, 6.0, 6.5, 7.0, 7.5, 8.0, 8.5, 9.0,  
10.0, 14.0, 21.0, 25.0

2.0, 2.6, 3.0, 3.5, 4.0, 5.0

0, 5, 15, 25, 35, 45, 60, 90, 180, 240 Msecs

15, 30, 45, 60 Min      4, 8, 12, 16, 20, 24 Hrs

0.98

10 Years

20 Years

Note: **Yellow** Denotes Fuze Panel Switch settings



# **FMU-152/B JPF PROGRAM OVERVIEW**



- **Program Phase: Production**
- **Contractor: Dayron**
- **Current Unit Price : \$2.167K**
- **Quantities: 62,000 (AF)/25,496 (Navy)**
- **Joint Service: Air Force (Lead)/Navy**
- **First Article Acceptance Testing - Summer 01**
- **JDAM High Altitude Low Airspeed Release Challenges**
  - **FZU- 55 Improvements - LRIP 2 and Beyond**
  - **Additional FMU-152 Improvements - LRIP 4 and Beyond**



# ***HARD TARGET SMART FUZE (HTSF)***



**FMU-159/B**



# **FMU-159/B HARD TARGET SMART FUZE PROGRAM OVERVIEW**

---



- **Program Phase: EMD**
- **Contractor: Alliant Techsystems**
- **Value: EMD \$18.5M, Prod \$34M**
- **Quantities: 500+ (AF) / 500+ (Navy)**
- **Joint Service: Air Force (Lead)/Navy**
- **“Smart” Fuze for Penetrator Weapons**
- **Allows Defeat of High Value Hard Targets**



# VOID SENSING, LAYER COUNTING, DEPTH OF BURIAL CAPABILITIES



- Contains a precision accelerometer and microcontroller
- Senses voids and layers, computes depth of burial
- Detonates warhead at user programmed point within target
- Programmable modes
  - Void or Layer Count, and Depth of Burial
  - Function Distance/Time after Void/Layer event
  - Redundant Backup Timer 0 to 255ms

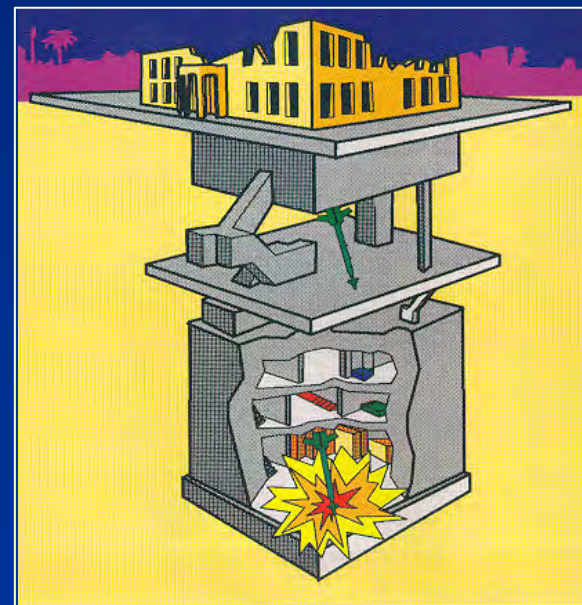
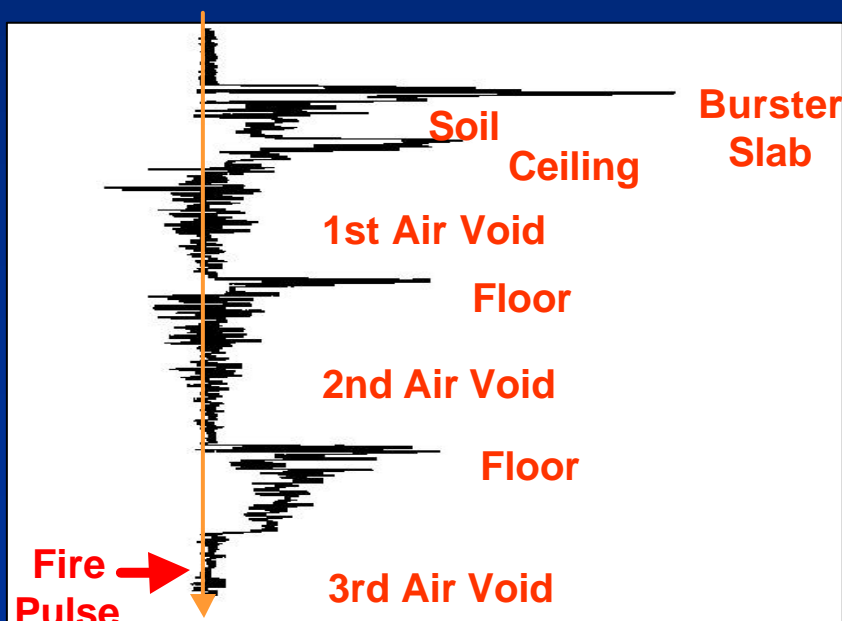



# FMU-159/B HARD TARGET SMART FUZE EMPLOYMENT PLATFORMS & WEAPONS



**B-52H**



**B-2A**



**F-15E**



**F-117A**



**AGM-86D  
CALCM Penetrator**



**GBU-37, EGBU-28**



**GBU-28, EGBU-28,  
GBU-24/27**



**GBU-27**



**F/A-18**



**F-14**



**GBU-24G/B  
(BLU-116)**



**Missile Cruisers & Destroyers**



**BGM-109H  
Tactical Tomahawk Penetrator**



# FMU-159/B HARD TARGET SMART FUZE SCHEDULE SUMMARY MAR 01

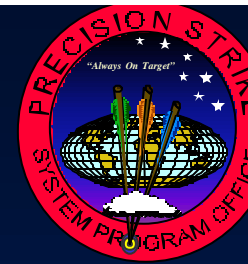

Task Name	Start	Finish	1999		2000				2001				2002			
			3	4	1	2	3	4	1	2	3	4	1	2		
<b>Contract Award</b>	8/11/98	8/11/98	■													
<b>Prelim Design Review</b>	3/31/99	4/1/99			■											
<b>Design/Development</b>	1/4/99	4/5/01			■											
<b>Critical Design Review</b>	5/10/00	5/11/00							■							
<b>Contractor Test &amp; Eval</b>	4/23/01	9/26/01										▲	■	▲		
Qual Tests	6/7/01	9/26/01														
Cannon Tests	4/23/01	6/13/01														
Sled Tests	6/25/01	7/25/01														
<b>PPO1 Exercise / Begin Build</b>	10/26/00	6/29/01										■		▲		
<b>DT&amp;E/OT</b>	5/1/01	2/12/02												▲	■	▲
FZU-60 Flt Test	5/1/01	6/29/01														
Sled Testing	8/9/01	12/4/01														
Flt Test	12/5/01	2/12/02														
<b>PPO2 Exercise / Begin Build</b>	7/17/01	12/11/01														
<b>NNMSB / WSESRB Final</b>	2/27/02	2/27/02														
<b>PCA / PRR MSIII</b>	3/6/02	3/6/02														



# DSU-33 PROXIMITY SENSOR

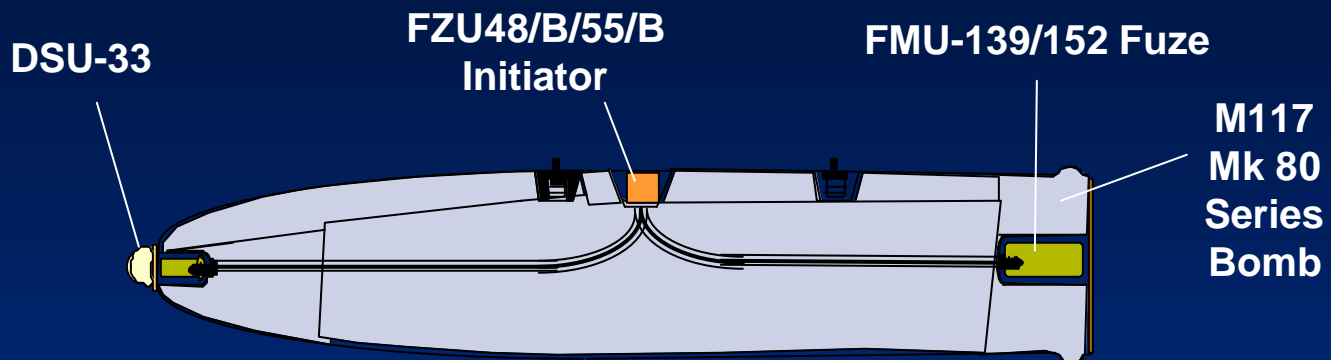

Air Force Configured System





# DSU-33 B/B PROXIMITY SENSOR

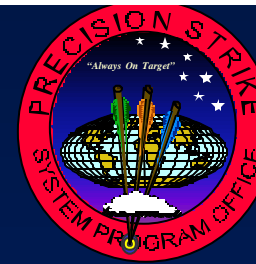

- **Current Production With Alliant Techsystems**
- **Air Burst Proximity Fuzing for Mk80 Series/m117 General Purpose Bombs and JDAM Variants**
- **Continuous Wave Doppler Radar Provides Fire Pulse Signal to the FMU-139 and FMU-152/B**
  - **Height of Burst (HOB): 20 Feet**
  - **Over All Water and Land Surface Conditions**
- **Attacks Surface Level Targets**
- **9,996 Units Delivered Thru Mar 2001 (AF & Navy)**
  - **3501 Remaining**

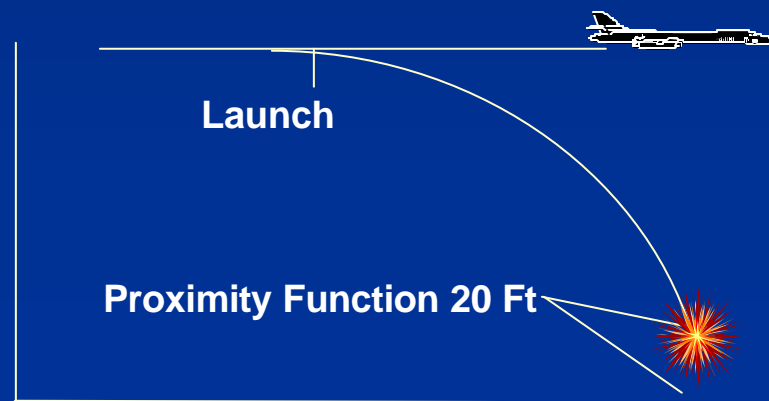



# ***CHALLENGES FOR TODAY'S AND TOMORROW'S FUZE PROGRAMS***

---



- **Shrinking Industrial Base**
- **Increasing Complexity & Cost**
- **Diminishing Verification Opportunities**
- **Aging Inventory**
- **Increasing Expectations**
- **Aircraft & Missile Interface Challenges**



# SHRINKING CONVENTIONAL FUZE INDUSTRIAL BASE

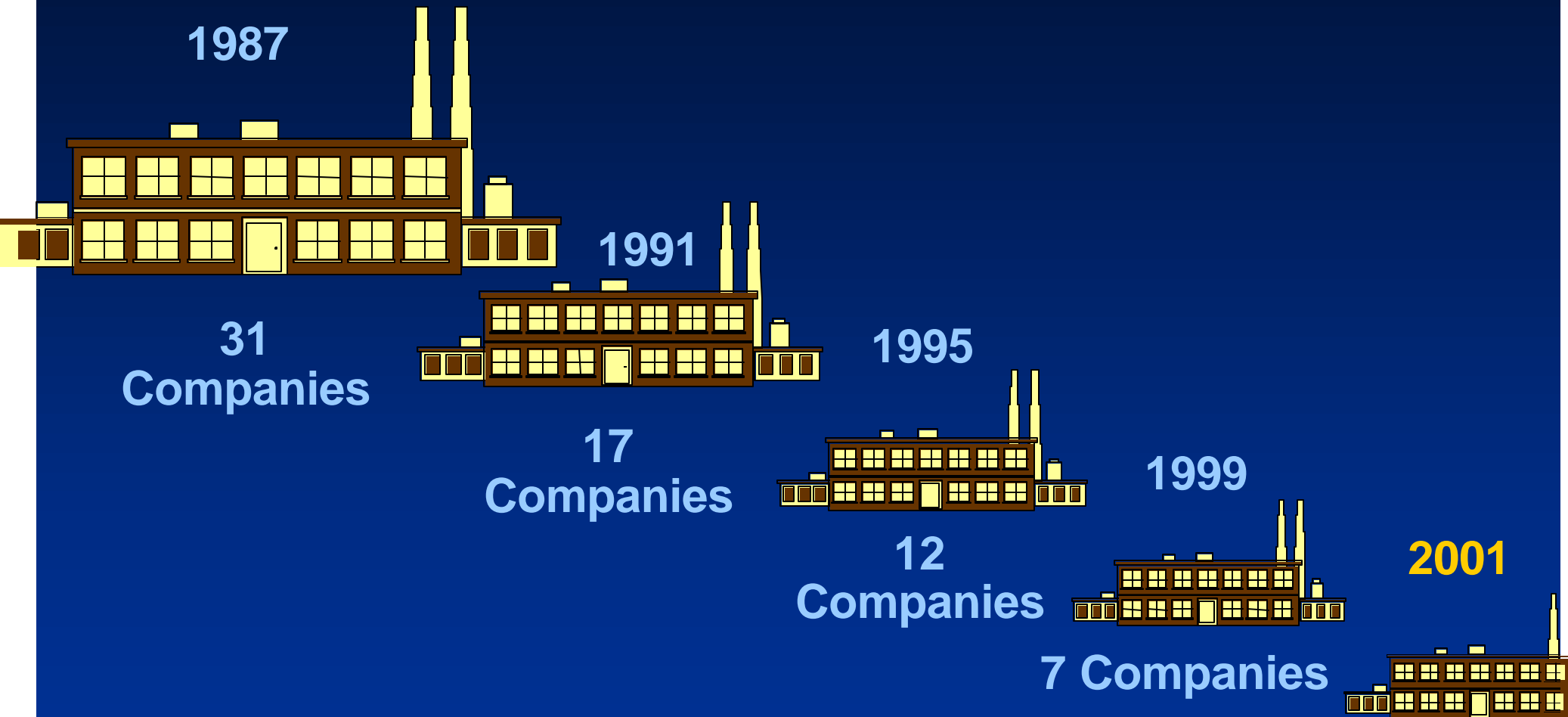

\* Source: Army Fuze Management Office  
JOCG Fuze Subgroup Meeting 11 Aug 99

**7 US & International  
Consortia**



# **SHRINKING INDUSTRIAL BASE**

## **(CONT)**

---



- **Funding Requirements in Support of Current Operations and Declining Acquisition Budgets Negatively Impact Development and Production Efforts**
  - **Fewer New Starts**
  - **Smaller Production Quantities Spread Over Longer Periods**
- **Increasing Reliance on Electronic Fuzing Reduces the Need for Older Mechanical Fuzes**
  - **Requires Higher Level of Technical Ability**
  - **Fuze Contractors Must Adapt or Face Dwindling Business**
- **Opportunity - DSU-33 Production Competition for FY 02-07 Requirements**



# ***SHRINKING INDUSTRIAL BASE*** ***(CONT)***

---



- **Erosion of Essential Human Resources**
  - **Technical Expertise is there, but in insufficient numbers**
  - **Lack of Technical Breadth/Experience impacts Problem Solving**
    - **No Technical Surge Capability**
    - **Failure Analysis Slow**
    - **Limited Understanding of Fuze Design and Operation**
  - **Government In-house Expertise is Retiring (Vietnam/Post-Vietnam era)**
  - **Recruiting and Retention is a major Challenge in this Market Sector**
- **JOCG Fuze Subgroup to Brief JOCG in Sep 01 on Industrial Base Status**



# **INCREASING COMPLEXITY AND COST**



- **Single Fuze Combining the Function of Several Fuzes**
  - e.g., FMU-152/B JPF Is Both a Blast-frag and Penetrator Fuze
- **Designs Take Advantage of Modern Electronics and Computer Technology**
  - More Versatile, More Precise
  - More Complex Sensing and Logic Functions
- **Mission Planning Becomes More Detailed and Critical**
- **FMU-159/B Hard Target Smart Fuze**
  - Void/layer Count, Timer, Back-up Timer
  - Programmable With 22 Settings on the Ground, 11 From the Cockpit
- **Multi-event Hard Target Fuze**
  - Thin Layer Detection, in Addition to Voids/timers
  - Cockpit Programmable
  - Fuze Information for Bomb Damage Information



# ***DIMINISHING VERIFICATION OPPORTUNITIES***

---



- **Advanced Fuze Verification Programs Are Very Expensive and Necessitate Limited Test Programs**
  - **Targets to Verify Fuze Performance Are Large, Multi-floor Structures**
- **FMU-152/B - 5 Sled Tests, 193 Flight Tests (DT/OT)**
- **FMU-157/B (ACTD) - 23 Sled Tests, 32 Flight Tests**
- **FMU-159/B - 18 Sled Tests, 11 DT Flight Tests, 2 OT Flight Tests**
  - **No AF GBU OT&E Because of High Cost and Limited AFOTEC Budget**
  - **Original AF GBU OT&E Planned for 13 Flights Using 19 Weapons**



# AGING INVENTORY



- **Much of Fuze Inventory Is Approaching End of Expected Life**
  - **Historically at 20 Years Reliability Problems Begin**
  - **AF Generally Accepts Older Fuzes at 90% Reliability With 90% Confidence**
    - **After That Either Double Fuze or Put 2 Weapons on Target**
- **Reliability of Older Fuzes Is a Current Issue**
  - **FMU-124B/B Surveillance Testing Failures (6 out of 72)**
- **Lack of Comprehensive Replenishment Plan**
  - **Insufficient Budgets to Efficiently Replace Older Inventory**
- **Refurbish or Replace?**
  - **FMU-139**
    - **AF - Replace With FMU-152 Over Time**
    - **Navy - Rebooster Challenges**



# **INCREASING EXPECTATIONS**



- **Warfighters Expect “First Time - Every Time” Performance**
  - Objectives of 98% Reliability
- **“Smart” Communications**
  - Cockpit Programming Is Now Standard
  - Bomb Damage Information Is Desired for the Future
- **Fuze Must Perform in Ever-expanding Performance Envelopes**
- **Fuze Design Capturing System Responsibilities**
  - High Altitude, Low Airspeed Release Conditions
  - Navy Fuze Function Control Set (FFCS)
- **Safety Certification of Electronic Fuzes Is More Difficult Than Mechanical Fuzes**
  - Old Paradigms Don’t Apply



# **AIRCRAFT AND MISSILE INTERFACE CHALLENGES**

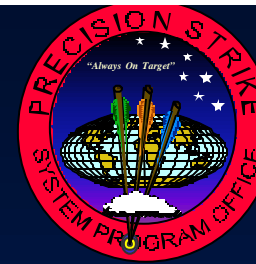

- **Navy Fuze Function Control Set**
  - **Anomalies Yielding Low Reliability With Electrically Fuzed Bombs (E.G., F/A-18 - 88%)**
- **High Altitude - Low Airspeed Release**
  - **Initiator Turbine Starved for Air Causes Arming Problems**
  - **JDAM Roll Stabilized Flight and AoA Compounds the Situation**
- **Long Term Storage Reliability and Safety Requirements While Installed in Cruise Missiles**
- **Allied Interoperability**
  - **Fuze Well Size**
  - **Fuze Power Source**
  - **Communications Interface**



# **POSITIVE RESULTS**



- **Significantly Increased Capabilities**
  - **Performance Characteristics**
    - **Void/layer Detection**
    - **Increased Survivability**
    - **Cockpit Programmability**
  - **Very High Reliability Requirements**
    - **HTSF and JPF - .98 (Mission), .95 (Storage)**
    - **MEHTF - .99 (Mission and Storage) Goal**
- **Joint Programs Are the Norm**
  - **DSU-33, JPF, HTSF**
- **Growing Realization of Critical Nature of Fuzing**
  - **Fuzing Is Small Diameter Bomb's (SDB) #1 Risk**
  - **HTSF Is on CALCM 86-D Critical Path**
  - **Major Growth Area for JDAM**



# Video

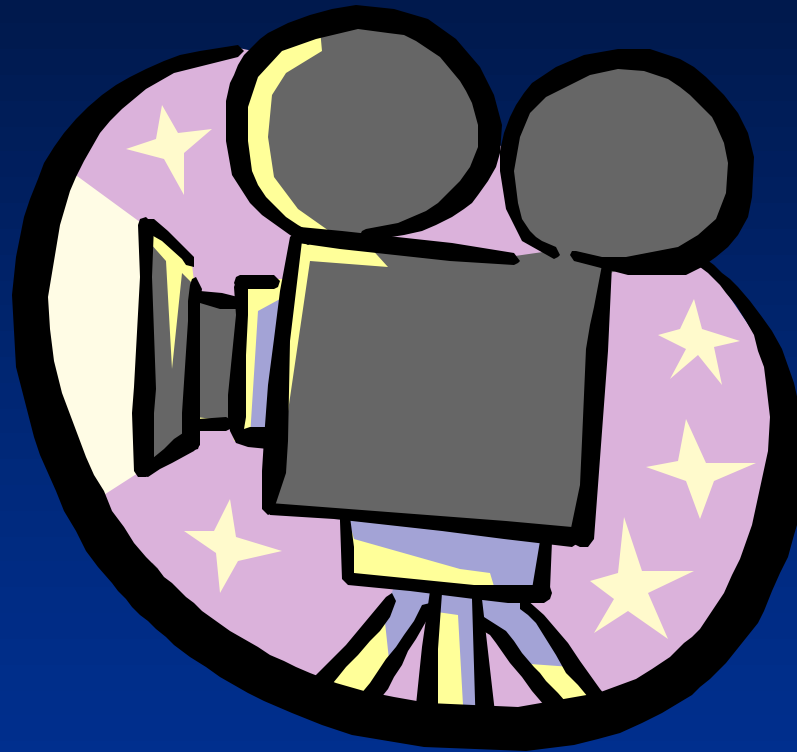



**Any Questions?**

# **45th Annual NDIA FUZE Conference 17-18 April 2001**



## **PEO Tactical Missiles**

**COL Jody Maxwell, Director  
System Integration & Operations**



# PEO TACTICAL MISSILES OVERVIEW



# PROGRAM EXECUTIVE OFFICER TACTICAL MISSILES

## MISSION

**Provide the American Soldier with the finest, combat effective, tactical missile systems in the world in a timely and cost-effective manner while fully supporting The Army's transformation.**

## VISION

**A world-class government / industry team that gives the American soldier an unparalleled, overmatch tactical missile capability that allows our Army to fight and win on the 21st century battlefield with minimal casualties in the shortest time possible.**

## GOALS

- **Excel beyond all others in fielding the best tactical missile systems in the world.**
- **Effectively team with industry.**
- **Build the Army Acquisition Corps of the future.**
- **Mature & weaponize critical technologies for the Objective Force.**
- **Reduce the Life Cycle Cost & in-theater logistics footprint of our missile systems.**



# PEO TACTICAL MISSILES

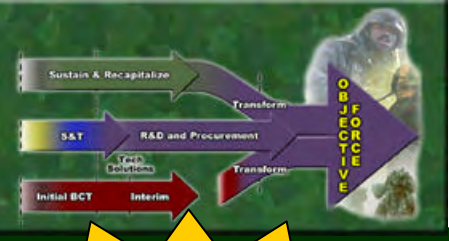

**PEO TACTICAL MISSILES**  
 DEPUTY PEO  
 PRINCIPAL STAFF  
 EUROPEAN REP

**FY00 MANPOWER REQUIREMENTS**

	<u>CORE</u>	<u>MATRIX</u>
CIVILIAN	281	611
MILITARY	37	10
CONTRACTOR	76	502
<b>TOTAL</b>	<b>394</b>	<b>1123</b>

**PM AVIATION ROCKETS & MISSILES**  
 LONGBOW HELLFIRE ACAT IC  
 LASER HELLFIRE  
 HYDRA 70  
 MODERNIZED HELLFIRE  
 APKWS

**AVIATION**

**PM ATACMS - BAT**  
 ATACMS / BAT ACAT ID  
 BAT  
 BAT P3I  
 BLK II  
 ATACMS / APAM ACAT IC  
 BLK I

**PM MLRS**  
 M270A1 ACAT1C  
 IFCS ACAT III  
 ILMS ACAT III  
 ER-MLRS ACAT III  
 GMLRS ACAT III  
 HIMARS ACTD

**FIRE SUPPORT**

**PM CCAWS**  
 TOW FIRE & FORGET  
 IBAS ACAT II  
 ITAS  
 T2SS

**PM JAVELIN**  
 JAVELIN ACAT IC

**PM KINETIC ENERGY MISSILES**  
 LOSAT ACTD+

**MANEUVER**



# FAMILY OF DEEP FIRES GUIDED ROCKETS AND MISSILES

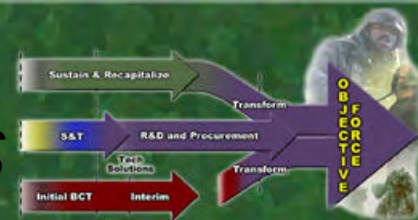

## ROCKETS

### NEAR-TERM (FY00 - 07)



### MID-TERM (FY08 - 16)

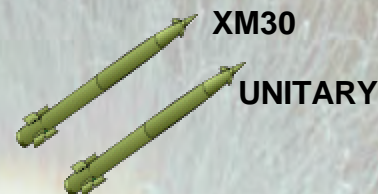

### FAR-TERM (FY17 - 25)

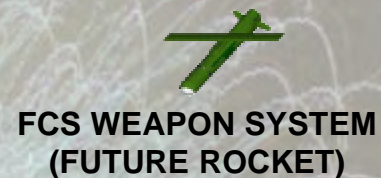

## MISSILES

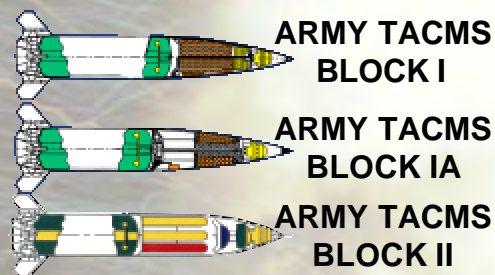

### ARMY TACMS BLOCK II



CONTINUOUS TECHNOLOGY INSERTION

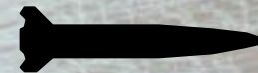

FUTURE MISSILE



BAT



BAT P3I



TACMS 2020

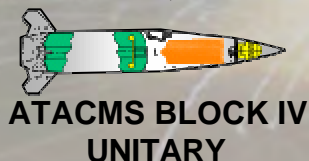

ATACMS BLOCK IV UNITARY

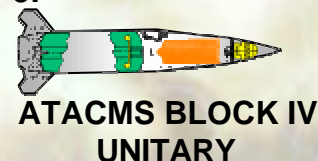

ATACMS BLOCK IV UNITARY

## LAUNCHERS



M270A1

HIMARS



M270A1

HIMARS



FCS



HIMARS



FCS



# FAMILY OF MANEUVER AND AVIATION MISSILES

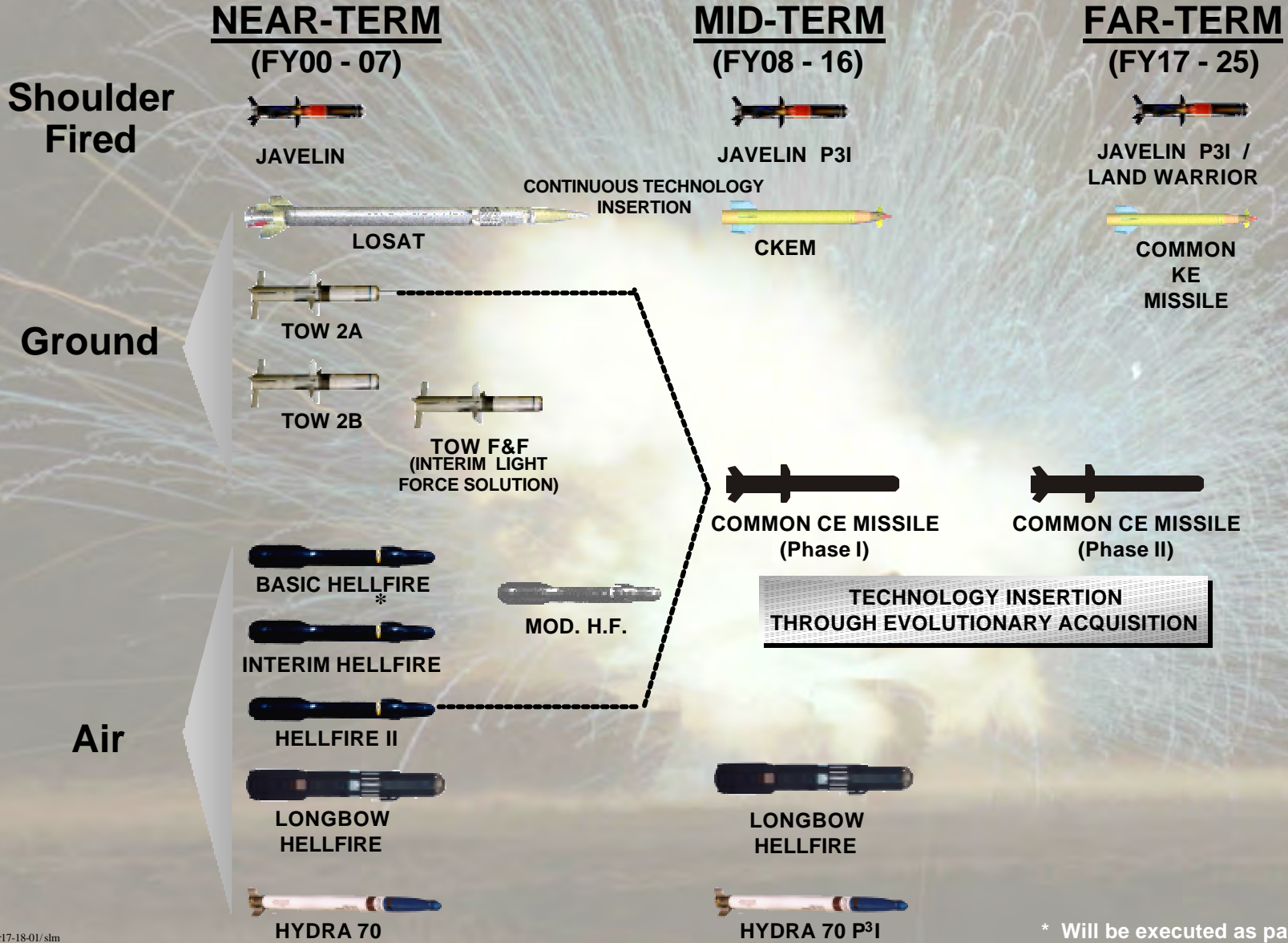
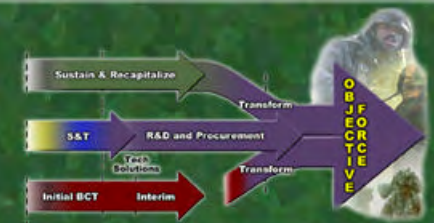



# FIELDING TO THE FORCE



## FUE: LAST FOUR YEARS

## NEXT TWO YEARS



JAVELIN - JUL 96



IPDS LAUNCHER - FEB 98



BLK 1A - FEB 98



HIMARS (PROTOTYPES)  
FEB 98

LONGBOW - JUL 98



ITAS - SEP 98



ER-MLRS MAR 99

FIELDINGS CONTINUE

IBAS  
AUG 00



M270A1 UPGRADE  
SEP 01

ATACMS BLK II  
SEP 01



OPTEMPO IS INCREASING



# Proposed Organization

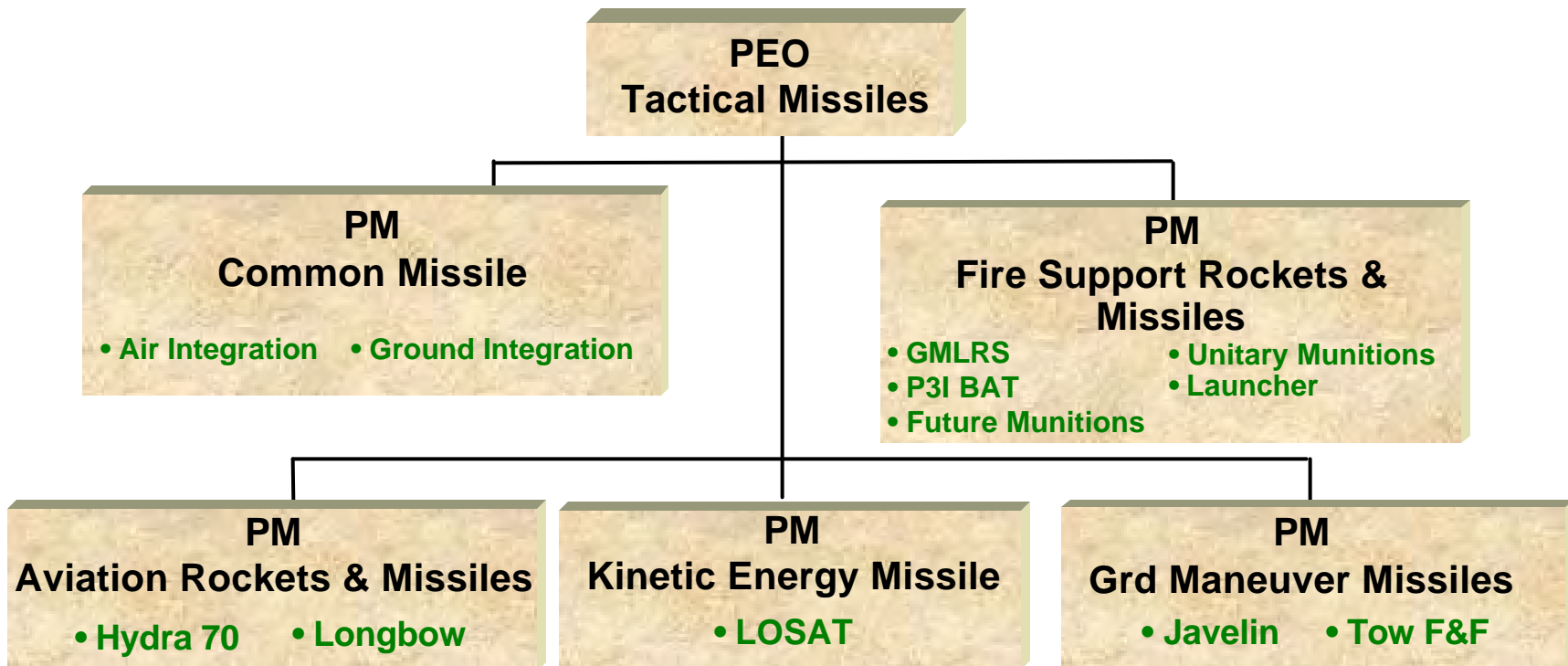
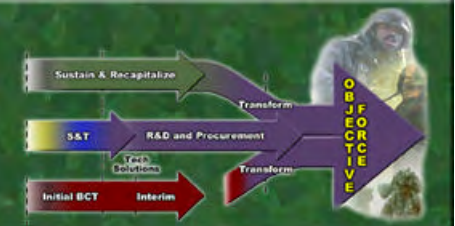



# THE SITUATION

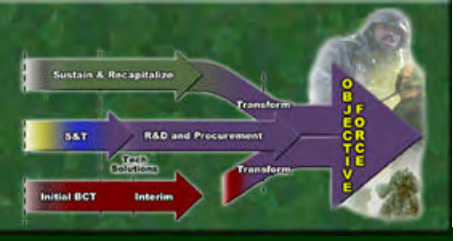

- In 1991 Following Desert Storm a requirement for <1% hazardous duds left on Battlefield was established
- Analysis of proposals indicated SDF as the most feasible option to meet the user requirement
- SDF development contract issued in 1992 with planned incorporation into ER MLRS in 1998
- To date Tactical Missile PEO has expanded approximately \$64M for development, testing of HRE, and LRIP for XM 235 SDF



# THE RESULTS

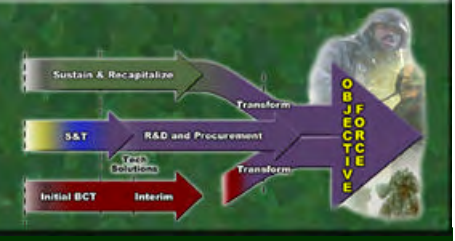

- The Production of ER MLRS began in 1996 without a SDF
- FMS cases have been lost and others are jeopardized due to the lack of a SDF
- HRE will not meet required rate
- Proposed HRE recovery plan is high risk
- LRIP contract terminated

**Bottom Line: Over ten years and \$64M invested in a solution for <1% hazardous duds with no acceptable solution in sight**



# TECHNOLOGY TRENDS

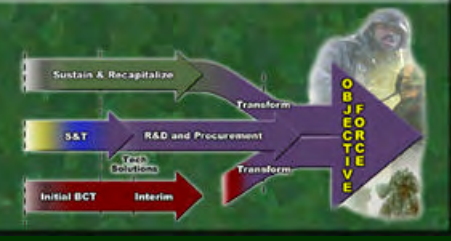

**FIRE AND FORGET TECHNOLOGY**

**FOCAL PLANE ARRAY (FPA)**

**DUAL MODE / MULTI-MODE SEEKERS**

**DEWAR DETECTOR COOLERS (DDC)**

**TANDEM WARHEADS**

**INERTIAL MEASUREMENT UNITS (IMU)**

**GLOBAL POSITIONING SYSTEMS (GPS)**

**GLOBAL POSITIONING SYSTEMS GUIDANCE PACKAGE (GGP)**

**ELECTRONIC SAFE AND ARM ES&A DEVICES**

**ADVANCED SIGNAL PROCESSING**

 **THESE TECHNOLOGY TRENDS BRING TECHNOLOGY CHALLENGES**

 **FUZE TECHNOLOGY DEVELOPMENT MUST KEEP UP WITH ADVANCES IN TECHNOLOGY**



# PATH FORWARD

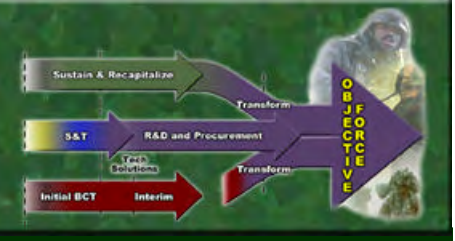

- **U.S. is committed to lower UXO on the Battlefield**
- **New DOD Policy issued 10 Jan 2001 stating a desire to field future submunitions with a 99% or higher function rate**
  - **“Future” submunition weapon is one that will reach MS II after first quarter of FY 2005**
- **It’s clear we can’t continue to do business as usual**
- **Consider other FUZE designs (Improved mechanical, Pyro delays)**
- **Most promising option is to pursue a Co-operative development of a European SDF that will transfer the qualified design to a US contractor for production**



# PATH FORWARD

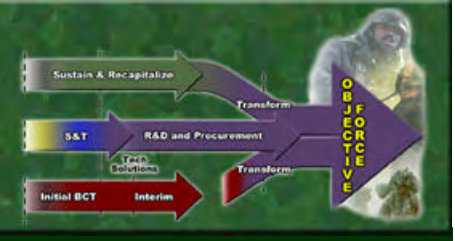

- **Industrial base must define common architecture**
- **Combine performance & environmental requirements for targeted programs**
- **Common module approach**
  - Flexible hardware building blocks
  - Programmable for multiple applications
- **Common Components**
  - Configured to adapt to peculiar system interfaces
  - Packaged to accommodate worst case scenario
- **Partitioned for Growth**
  - Unique functions & interfaces segregated



# CONCLUSION

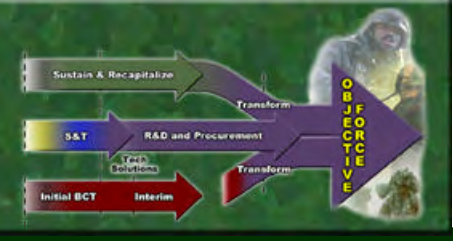

- **Concern over dirty battlefield is increasing as evidenced by 99% UXO requirements**
- **Quantities and funding for specific weapons systems are decreasing**
- **Fuze industrial base must develop designs that are transportable to other systems. Production facilities must be capable of producing more than one item at high rates**

**We simply cannot afford to develop and support new unique pinpoint designs for each system**

# Naval Air Systems Command Fuzing Overview

Steven E. Fowler  
Head, Ordnance Systems Division  
Code 478000D  
Naval Air Warfare Center, Weapons Division



# Naval Air Warfare Center Weapons Division



# A Full-Spectrum Capability



# Missile Engagement Simulation Arena



- **Products and Services**

- **Fuze**
  - Testing and evaluation
  - Consultation on design and testing methodologies
- **Diverse Testing operations**
- **TDD Foreign Military Exploitation**
- **Field test consultation**
- **Portable radar signature/ antenna testing**

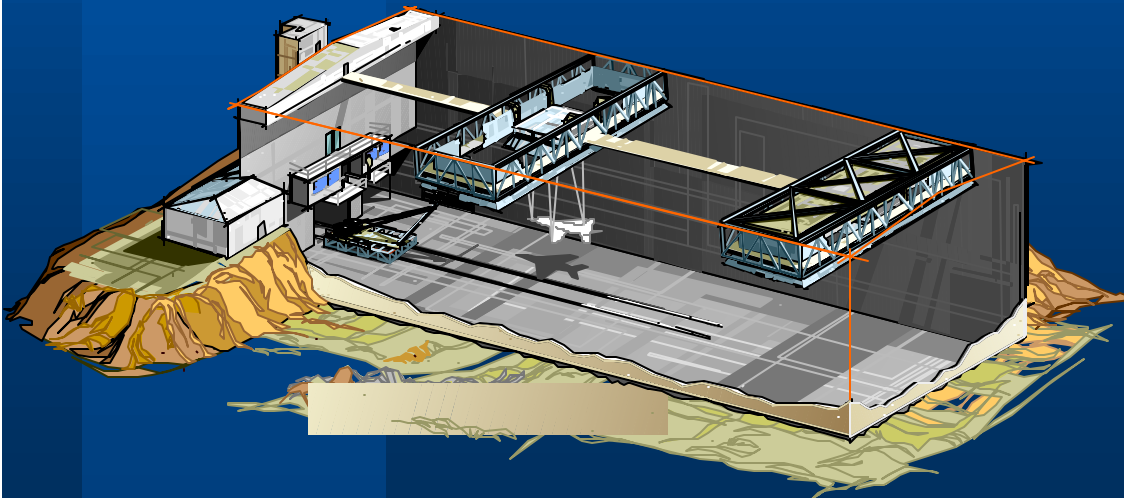

**Length = 405 Ft**  
**Width = 150 Ft**  
**Height = 90 Ft**

# MESA Testing of Full-Scale Aircraft



F-4 Fighter



Fuze Testing Against F-18

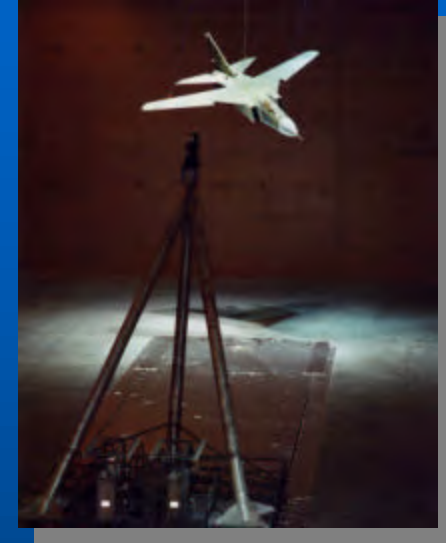

Mig-23 Fighter

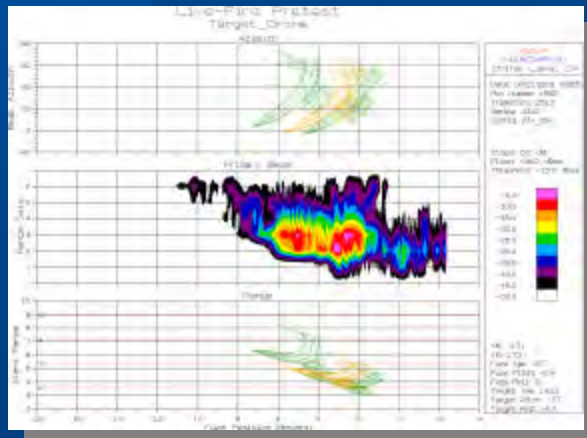

Example of Fuze Data Results

- Guidance and Fuze Testing
  - Fuze Design and Development
  - Fuze optimization
  - Platform survivability
  - Terminal guidance investigation

# *Fuze Systems*

# Missile S-A Devices



**HARM MISSILE FUZE,  
FMU-111/B**



**TOMAHAWK BLK 3 FUZE,  
FMU-148/B**



**SLAM ER, FMU-155/B**



**PHOENIX MISSILE FUZE,  
FSU-10/A**



**SPARROW MISSILE S-A, MK-33**



**SIDEWINDER MISSILE FUZE,  
MK-13 MOD 2**



**STANDARD MISSILE  
S-A, MK 54 MOD 0**

# Missile Target Detecting Devices



**RAM  
MK-20 AOTD**

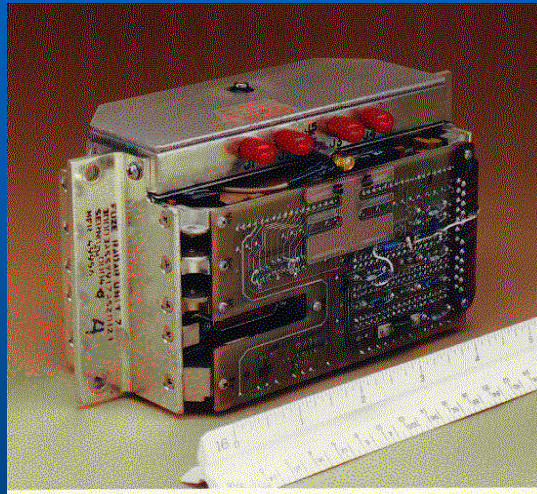

**SEA SPARROW/ESSM  
DSU-34 TDD**



**Standard Missile  
MK-45 TDD**

# Free-Fall Weapon Fuzes



FMU-139 A/B, Electronic Bomb Fuze



DSU-33B/B Proximity Sensor



FMU-143, Electronic Bomb Fuze



FMU-140 /B, Dispenser Proximity Fuze

# FMU-139 Rebooster Program

- FMU-139, joint in-service, general-purpose fuze
- The FMU-139B/B is a retrofit to the current FMU-139A/B fuzes
- Improvements include:
  - Replacement of CH-6 booster pellets with PBXN-7
  - The addition of two (2) transvoltage suppressors
  - Replacement of explosive leads with new leads
  - Elimination of the MK-3 Arming Wire
- Production startup January 2000
- 200,000 FMU-139B/B fuzes completed by the end of FY 01



# Support for Joint Fuzes



**FMU-159**  
**Hard Target Smart Fuze**



**FMU-152**  
**Joint Programmable Fuze (JPF)**

# Fuze Technology Programs

# Low Energy EFI Technology

- **State Of The Art**
  - Low Energy Exploding Foil Initiators
  - Alternative Explosive Materials
  - Increase Energy Output
- **Benefits**
  - Significant Cost Savings to the Navy
  - Significant Performance Enhancements



Low Energy EFI Detonator  
- Fully Qualified  
- Manufactured by Silicon  
Designs and Reynolds  
Systems



EFI Firing a Booster

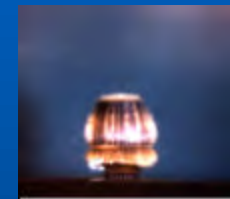

Booster Detonating



Integrated EFI with Solid State Fire Set

# MEMS-Based Distributed S-A

- **Description:**
  - Master control unit senses arming environments per MIL-STD-1316, then generates unique arming commands to selected “slave” detonators
  - Each det contains MEMS mechanical locks to prevent inadvertent arming
  - Up to “n” dets distributed within system to enhance performance
- **Major Accomplishments:**
  - Safety analysis of arming commands
  - Shown MEMS ability to move loads
  - Proven basic in-line, out-of-line safety
  - Shown transfer of small charges
  - Significant size reduction of electronics
- **Future Plans:**
  - Complete design
  - Demonstrate Feasibility
  - Integrate Electronics/MEMS/Explosives

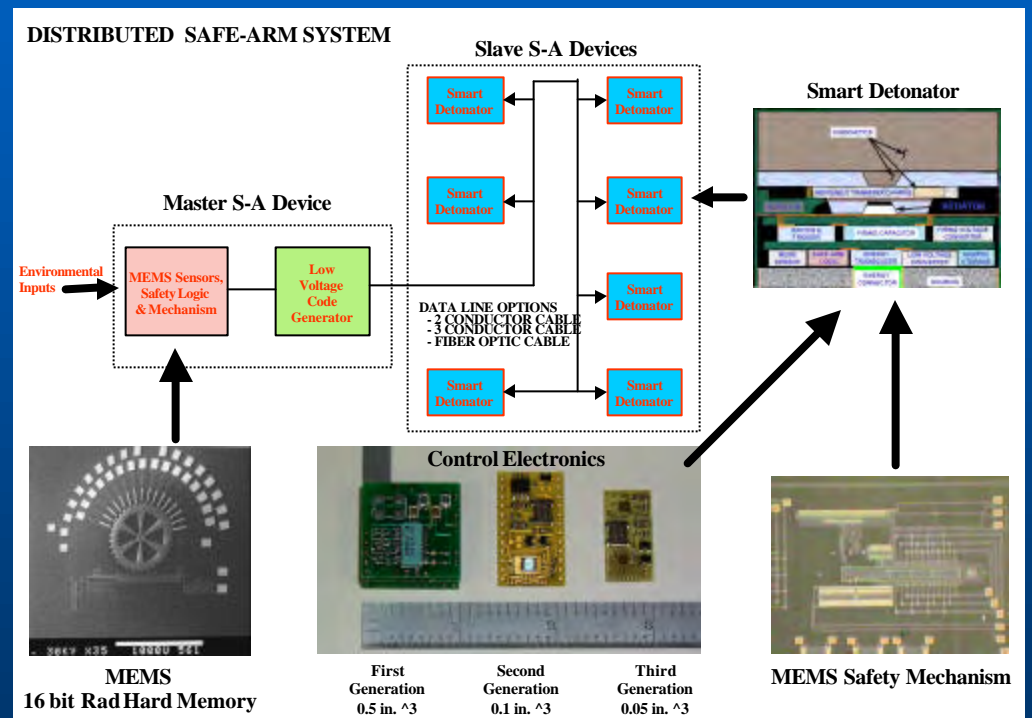

# Enabling Fuze Technology

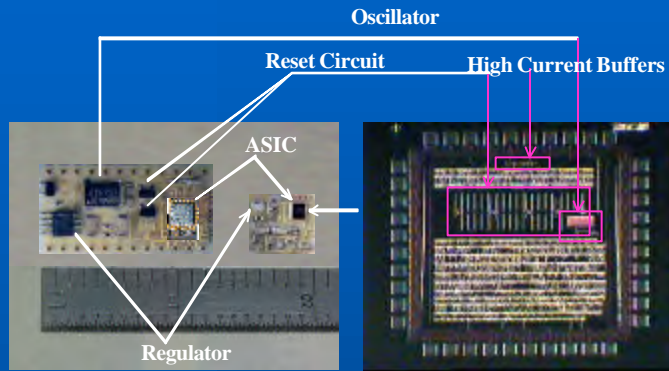

Miniature Electronics and Mix Signal ASIC

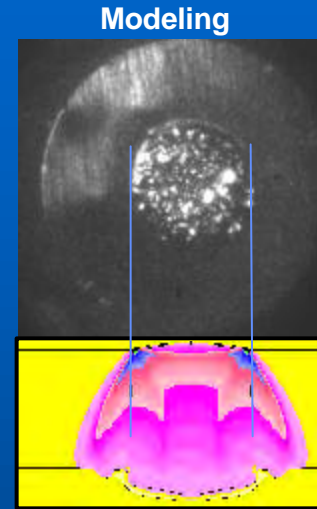
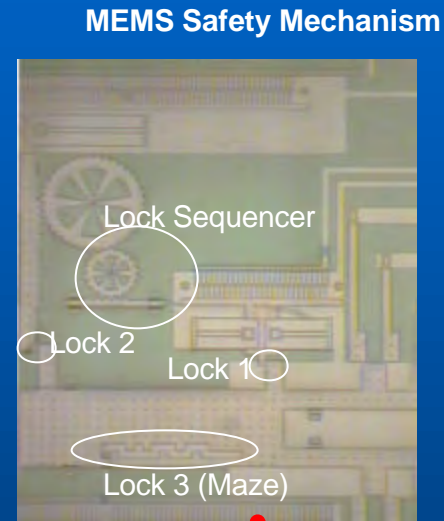

Hydrocode prediction and test results

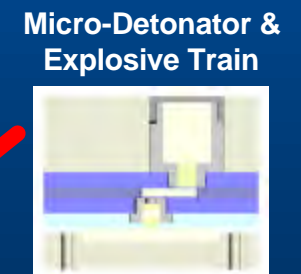

MEMS Sensors  
Weapon Data  
Arming Environments

Electronic Safety Logic

Optional

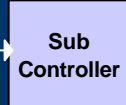

Fuizing System

# MEMS Based Distributed S-A (cont'd)

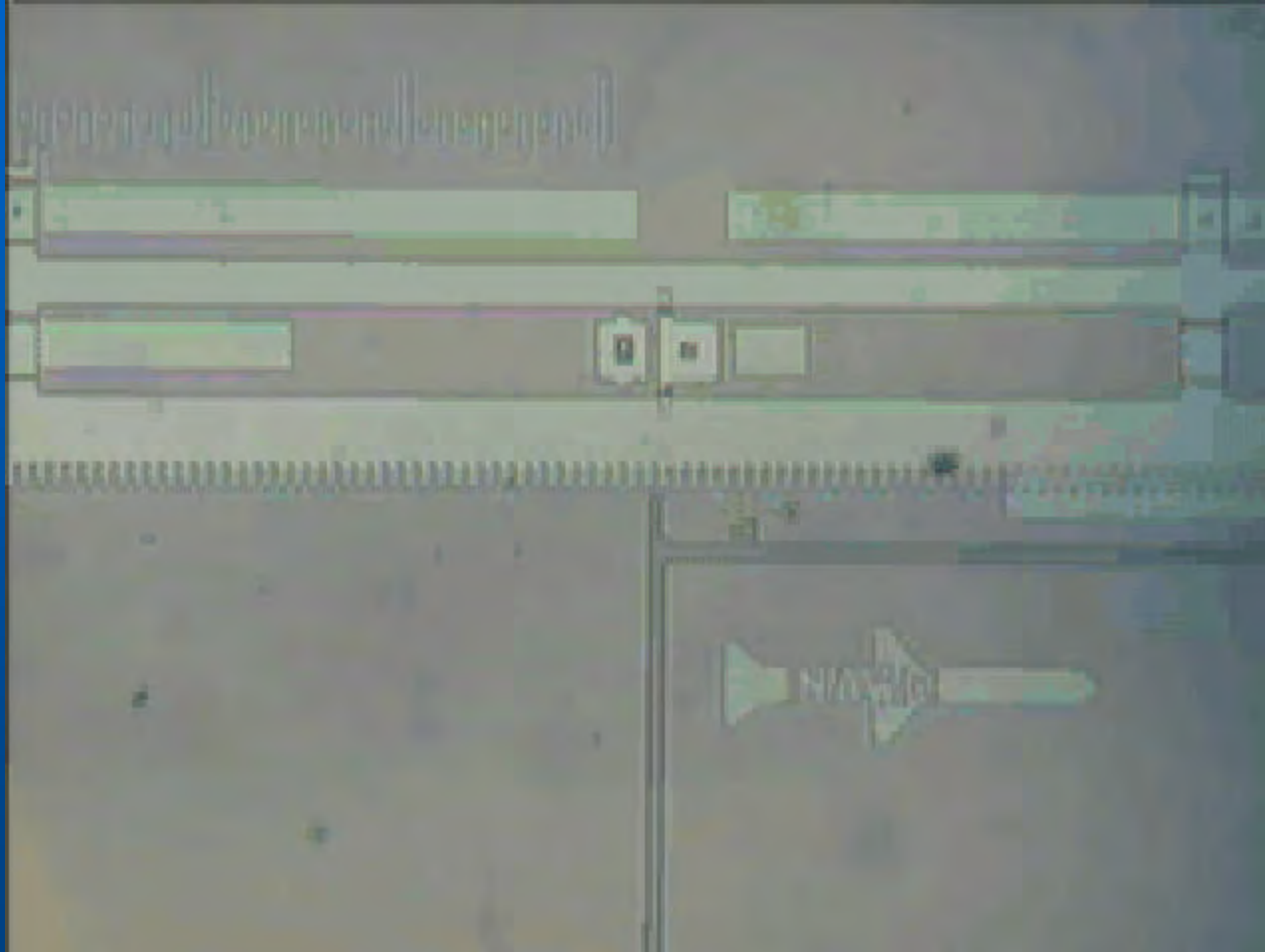

Computer controlled rack driver

# Precision Intercept

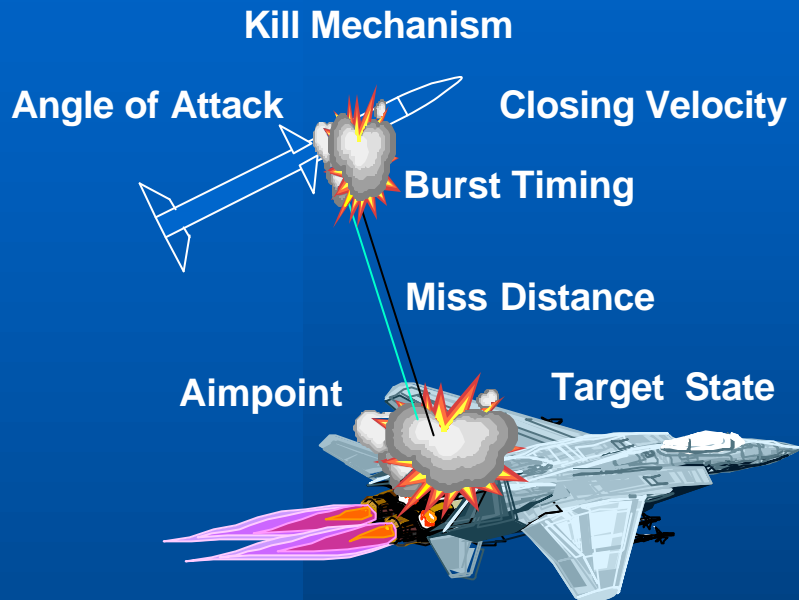

## What Are We Trying To Do

- Develop methods to produce missile management algorithms that maximize missile lethality
- Manage intercept conditions for optimal lethality using:
  - Target state information from missile sensors and network centric warfare grid
  - Missile endgame trajectory and attitude w.r.t. target orientation
  - Warhead mode options
  - Knowledge of target-warhead vulnerability space

## What Makes it Possible

- High resolution forward-looking endgame sensors
  - Reduce measurements errors
  - Target extent and orientation information
- Taking advantage of synergies between warhead/target information and missile dynamics
- Modern processors can support higher processing loads

## What Difference Will it Make

- Greater Pk over wider encounter conditions & spectrum of target types
- Offers reduced weapon size / weight by providing same lethality with smaller warhead

# Short Pulse Laser TDD

## • Objective

- Provide High Endgame Lethality For SBD Against Sea Skimming Supersonic Maneuvering Targets In Benign and Adverse Environmental Conditions
- Extend the Operational Capability of Fuzing Subsystems to Include:
  - All Aspect Encounter
  - Adverse Weather
  - Increased Target Sets
  - Low Altitude Severe Clutter Operation
- Demonstrate operation in adverse weather to Support Warhead Lethal Range
- Apply Advanced Sensor and Receiver Technology to Low Altitude SBD Problem

## • Approach

- First Order Analysis Shows Good “All Weather” Capability
  - Short Pulse Laser Sensor
    - Discriminates Against Aerosols and Clutter
    - Target Profiling
- High Peak Power Narrow Pulse Laser Transmitters Offer:
  - Small Size and Volume
  - Large Target to Aerosol Backscatter Ratio
- High Bandwidth / High Gain Receivers Offer:
  - Increased Signal to Noise Ratio
  - Increased BW & Sensitivity for Short Pulses



## • Payoff

- Increased Pk Against SBD Targets
  - Adverse Environmental Conditions
    - Aerosol
    - Sea Clutter
- All Aspect Encounter

# SEAD Fuze



## Payoff:

- Improved Pk through direct target measurements
  - Independent of Terminal Approach

## Objectives:

- Direct target detection design
- Establish low probability of false alarm in clutter with a high probability of target detection
- Fuze cost compatible with missile platform

## Approach:

- Exploit MMW target/clutter discriminants using radar (amplitude, phase, polarization, etc.) and radiometric data
- Mature the target/clutter discrimination technologies through analysis, simulation, and critical experiments with a measurement sensor.

## Lessons Learned:

- Strike TDD requirement driver is false alarm rate on clutter
- Target/clutter discrimination based on return amplitude alone is not reliable
- Target/clutter discrimination demonstrated with polarization, phase, and radiometric methods
- Phase processing is least expensive
- Radiometry is lowest risk

# Summary

- Navy Lead for Missile and Free-Fall Weapons Fuzing

Supporting

→ Technology

→ Development

→ Production

→ In-Service

**NDIA 45th Annual Fuze Conference**  
**Ordnance Fuzing/Safety & Arming**  
**Programs Overview**



**Anh N. Duong**

**Explosives & Undersea Weapons Program Manager**  
**NSWC - Indian Head**



# OUTLINE

- ◆ **Current Development Programs**
- ◆ **Product Improvement Programs**
- ◆ **Applied MEMS Technology Programs**

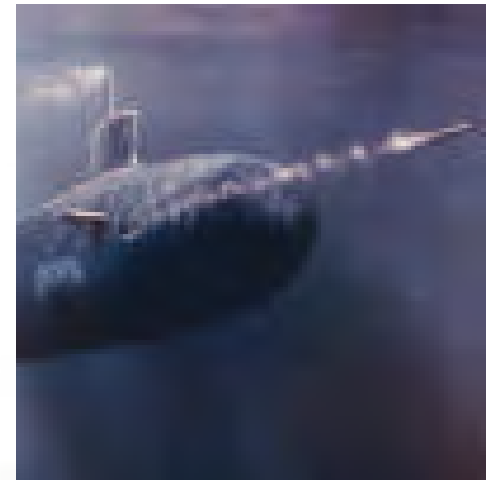
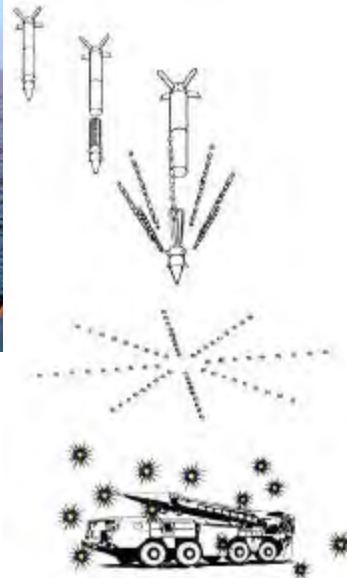



# Current Development Programs

## Navy Assault Breaching Systems

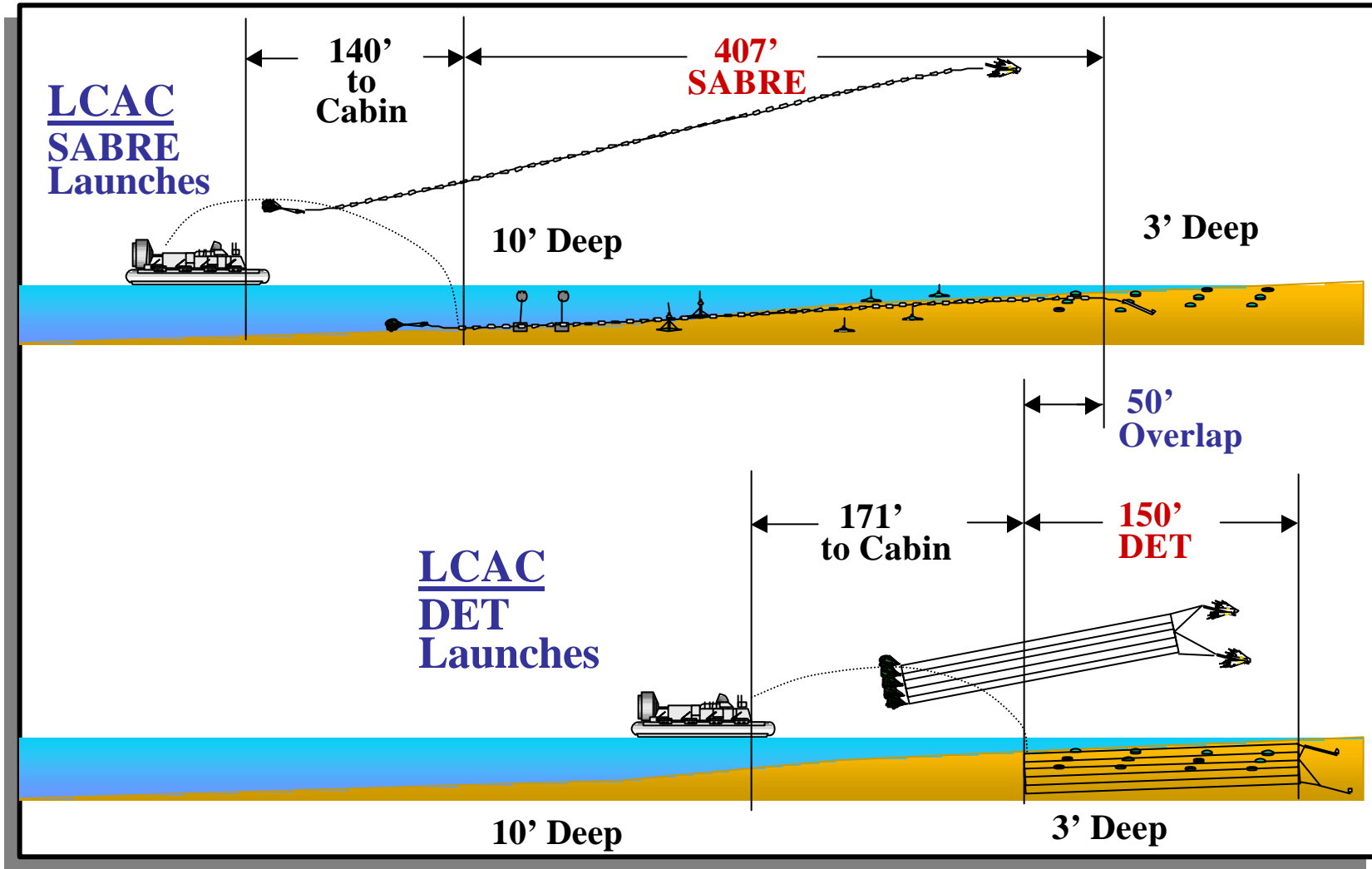



# DET SURF ZONE MINE CLEARANCE SYSTEM TEST





# DET Fuze/S&A

- ◆ **Distributed Explosive Technology (DET)**
  - **180'x180' Explosive Net Used in Surf Zone Mine Clearance**
- ◆ **All Mechanical Fuze/Safety and Arming Device**
- ◆ **DET Technical Evaluation Completed**
- ◆ **DET Operational Evaluation Currently on Hold**
  - **May be Combined with SABRE OPEVAL Scheduled FY03**

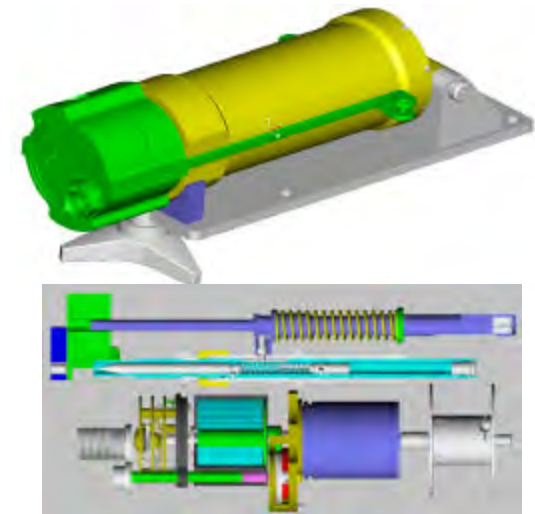
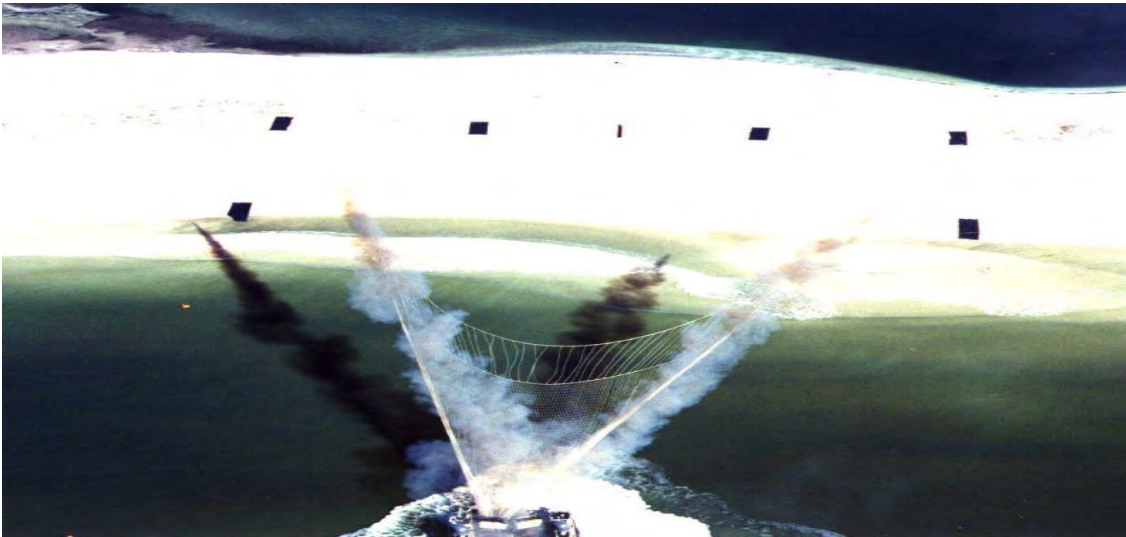



# SABRE Fuze/S&A

---

---

## **NEW START** -- *New Fuze/S&A for Shallow-water Assault Breaching (SABRE) System*

- ◆ **Contractor Development - Contract Award in Process**
- ◆ **Fire-and-Forget Fuze/Safety and Arming System**
- ◆ **Requires Extremely High Reliability**
- ◆ **Support SABRE System MS III Production Decision of March 2003**



# P3I Programs

## ◆ NSFS ERGM EX171 M80 Submunition PIP Proximity Fuze Insertion

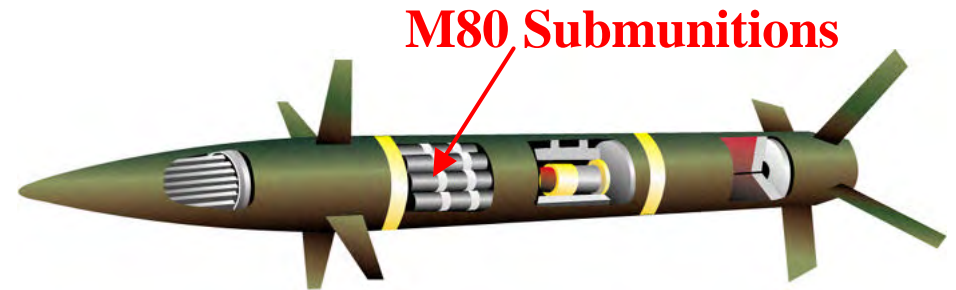
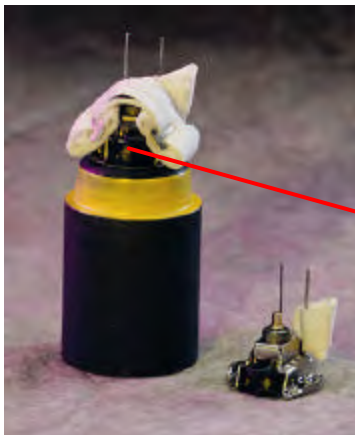

## ◆ Next Generation Small Active Electromagnetic Torpedo Fuze



**EM Fuzed Torpedo Shell Section**



# NSFS ERGM M80 Product Improvement Program (PIP)



## PROGRAM GOALS:

- ◆ **Develop an Add-on Proximity Fuze System**
  - **Inserted within the M234 SD Fuze Envelope**
  - **Minimal Impact to M234 SD Fuze High Rate Production Equipment**
  - **Meet ERGM Safety, Performance, Environmental, & Life Cycle Requirements**

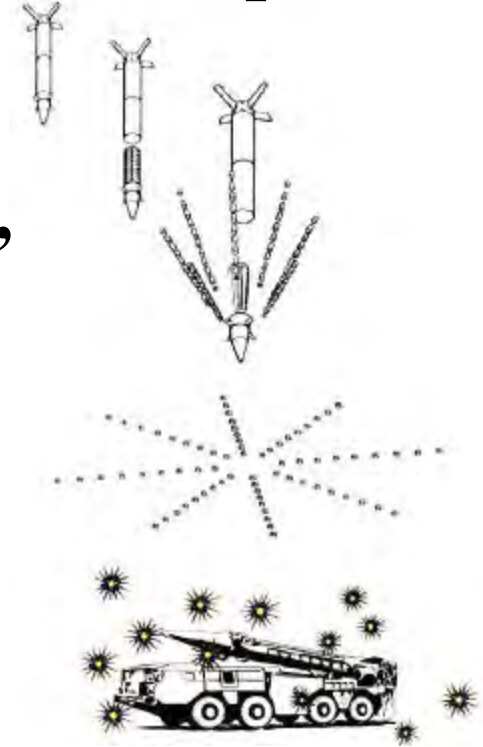



# NSFS ERGM M80 PIP

## *Proximity Fuze System Insertion*

### TECHNICAL APPROACH:

#### ◆ One-for-One Replacement of the M234 Self-Destruct (SD) Fuze Slide Assembly

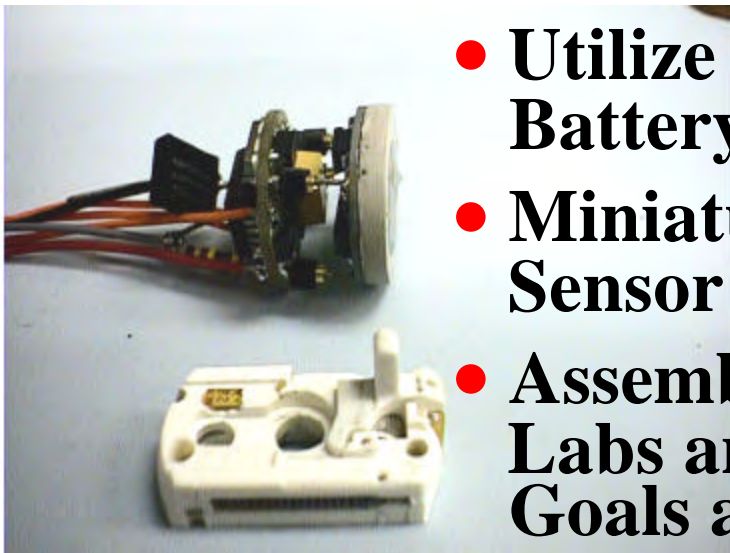

- Utilize Gun Launch Environment for Battery Activation
- Miniaturize the FM/CW RF Proximity Sensor of the M734A1 Mortar Fuze
- Assemble Expertise from Army / Navy Labs and Industry to Achieve Technical Goals and Reduce Critical Risk Areas





# Reduced Power Active EM Fuze Underwater Torpedo Applications



## Proof-of-Principle Demonstrated

- 7:1 Reduction Input Power
- Multiple Transmitter Designs
- Suitability of EM Fuzing for Small Diameter torpedoes

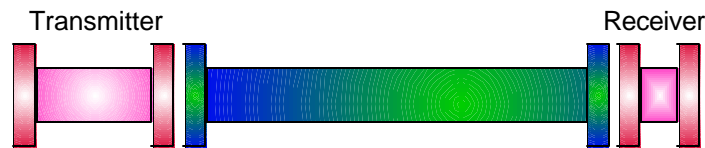

## Successful Torpedo Sea Run Tests

- Dynamic Environments
- Target Detection
- Model Validation

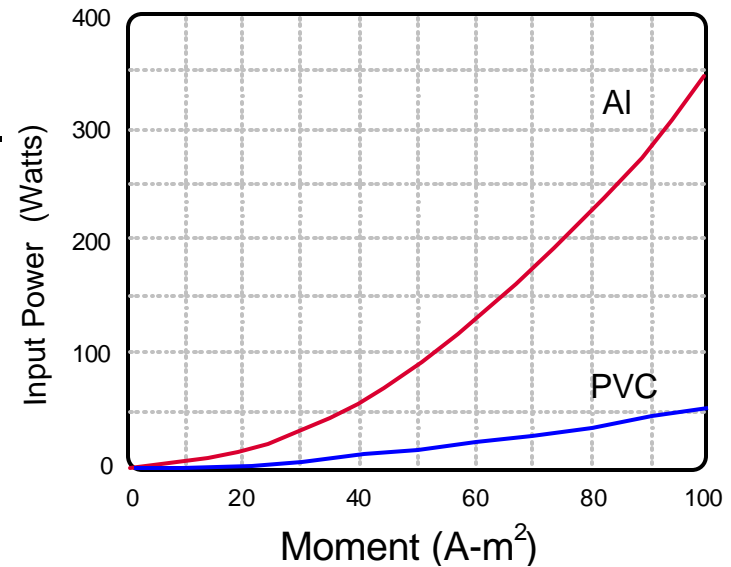



# Applied MEMS Technology



- ◆ Surface Ship ATT F/S&A Device
- ◆ Standard Missile Embedded Sensors
- ◆ Ordnance Inventory & Surveillance

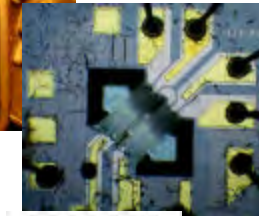
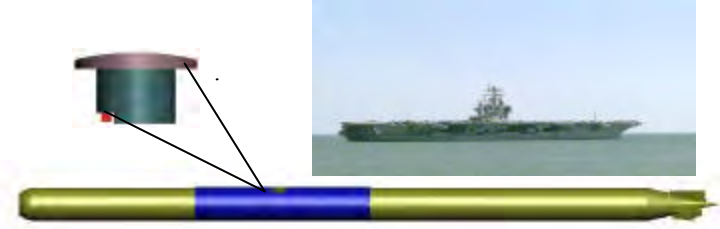



# NAVY MEMS-BASED F/S&A PROGRAM



## **OBJECTIVE:**

- ◆ **Apply & Transition MEMS Technology to Undersea Weapon F/S&A Systems**



## **APPROACH:**

- ◆ **Capitalize on the MEMS Industrial Base**
  - Commercial (COTS) Sensors & Devices
- ◆ **Leverage DARPA Funded Infrastructure**
  - Design, Modeling & Analyses Capability
- ◆ **Demonstrate MEMS F/S&A Reliability**
  - Assure Weapon Safety with Miniaturized Modular Architecture

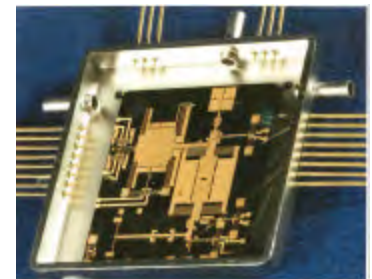



# MEMS F/S&A TECHNOLOGY COTS / Modular Components



**Impact Sensor**



**Flow Sensor:  
Pressure Differential**



**Inertial Measurement  
Rate Sensor**



**Typical Building Block Components  
for MEMS-Based Exploder**



**Initiation System  
Slapper, Fire-set & Optical  
Charging Circuit**

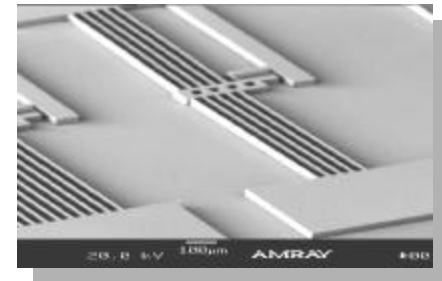

**DRIE MEMS CHIP**

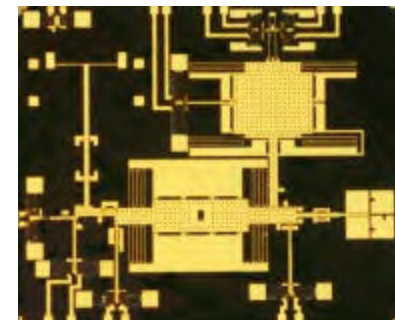

**LIGA S&A Chip**



# TORPEDO MEMS F/S&A



**Main Objective:** Transition MEMS F/S&A  
Technology for FY 02 CCAT E&MD Start

**Technology Focus:**

- ◆ MEMS Fabrication
- ◆ Packaging Reliability and Robustness
- ◆ Inertial Sensor (IMU) Technology
- ◆ Remote Initiation Systems
- ◆ Optical Interruption

**Prototype Development:**

- ◆ Develop/Build 15 S&A Prototypes
- ◆ Conduct Environmental and Field T&E
- ◆ Utilize IHD MEMS Clean Room for MEMS S&A Prototypes Packaging, Assembly, & Test

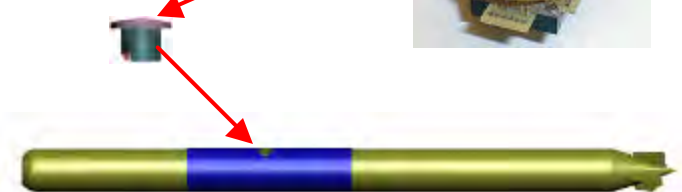



# Standard Missile

- ◆ Installing Temperature Data Loggers to Canisters
- ◆ Funded to Develop Embedded Stress Gauges
- ◆ Funded to Develop Embedded Ultrasonic Sensors





# Advanced Technology Ordnance Surveillance (ATOS)



- Selected by OSD as an FY 01 Advanced Concept Technology Demonstration
- Demonstrate operational utility of miniature radio frequency identification (RFID) tags coupled with micro-electromechanical sensor (MEMs) technology for use in tracking/monitoring critical items:
  - Joint “high dollar/low density” munitions
  - Category I munitions (high potential of theft/terrorist use)
  - Future Potential: Medical and biological supplies, perishable substance and other environmentally sensitive commodities, DU munitions, etc.





# MEMS Sensors



- Temperature
- Humidity
- Stress/Strain
- Acceleration
  - Shock/Vibration History
- Chemistry Lab on a Chip
  - Presence of Degradation Products
  - Stabilizer Depletion

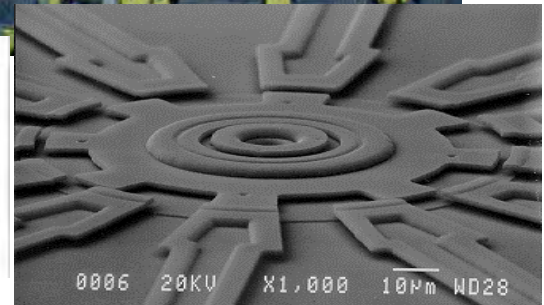
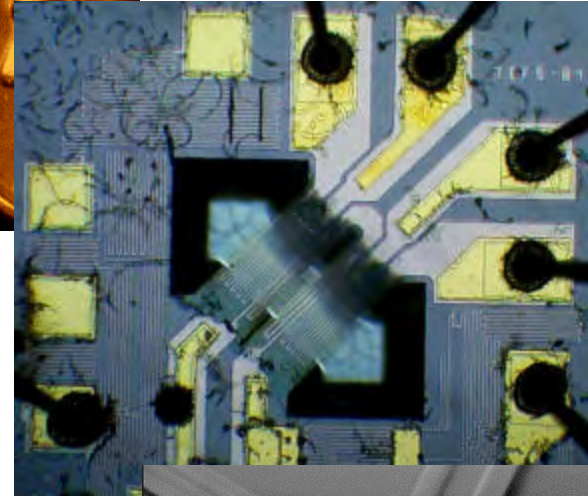
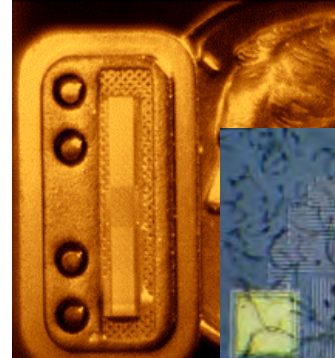



# FUZE / SAFE & ARMING FOR THE 21<sup>ST</sup> Century

## Challenges / Opportunities

- Shrinking DOD budgets / downsizing
- Affordable weapon systems / reduced LCC
- Smarter, multipurpose weapon systems
- Acquisition reform
- Maintain critical smart F/S&A core within DOD
- Miniaturization



## Approach

- Focus on electronics & emerging MEMS technology in industry
- Increase joint service collaborative efforts
- Develop “building Block” approach for universal application

# U.S. Army Materiel Command

COL(P) Vincent Boles

Deputy Chief of Staff for Ammunition

**Ammunition Update  
to 45th NDIA  
Fuze Conference**

**17 April 2001**



***AMC-Army READINESS Command... Supporting Every Soldier Every Day***

# ***Spectrum of Military Operations***



***Soldiers on Point for the Nation***

# Topics

---

- ★ ***Fuze Base Concerns***
- ★ **Munitions FAA 2000**
- ★ **Aging Stockpile**
- ★ **Recapitalization**
- ★ **Army Procurement**
- ★ **Fuzes in Production / Procurement**
- ★ **Thoughts I Want to Leave You With**
- ★ **Thoughts to Take Away**



# Fuze Base Concerns

- \* In Oct '00, Initiated Study to Look at State of the Power Supply Base*
  - \* Industry Participated & Provided Valuable Input*
  - \* Formulating Strategy to Support this Part of Base Critical to Future Smart Munitions*
  - \* Recap will Place Burden for Reserve Batteries in Self-Destruct Fuzes*
- 



# Topics

---

- \* **Fuze Base Concerns**
- \* ***Munitions FAA 2000***
- \* **Aging Stockpile**
- \* **Recapitalization**
- \* **Army Procurement**
- \* **Fuzes in Production / Procurement**
- \* **Thoughts I Want to Leave You With**
- \* **Thought to Take Away**



# Munitions FAA - 2000

- ✓ **Precision Munitions** - *can reduce Army Logistics Footprint, but pace is too slow . . . Multiple Participants . . . T.T.P. 6300 Rounds*
- ✓ **Serious Issues in Fire Support** - *cold war stockpile aging or declining, have delayed modernization*
- ✓ **Recapitalization Focus** - *support for Low Cost Competent Munitions to bridge modernization gap, extend shelf life of stockpile*
- ✓ **Industrial Base** - *Continue “commercialization” strategy to yield cost /process efficiencies with domestic/global competitiveness*



# Topics

---

- \* **Fuze Base Concerns**
- \* **Munitions FAA 2000**
- \* ***Aging Stockpile***
- \* **Recapitalization**
- \* **Army Procurement**
- \* **Fuzes in Production / Procurement**
- \* **Thoughts I Want to Leave You With**
- \* **Thoughts to Take Away**



# How Long Can We Rely on Aging Stockpile?

- \* *Increasing signs of age in current stockpile - major suspensions in 60MM, Mechanical Time Fuzes, older 120MM tank ammunition*
- \* *Decision to exclusively use SD-fuzed submunitions would require replacement/remanufacture of 4 M+ DPICM munitions and 100K MLRS -potential \$22B bill*
- \* *Over \$100M in deferred maintenance on stockpile munitions - backlog growing - mainly substitute munitions*

*Army is facing need to recapitalize conventional munitions stockpile within next 10 years*

**OR PUT ANOTHER WAY...**



# Aging Stockpile - 155MM DPICM

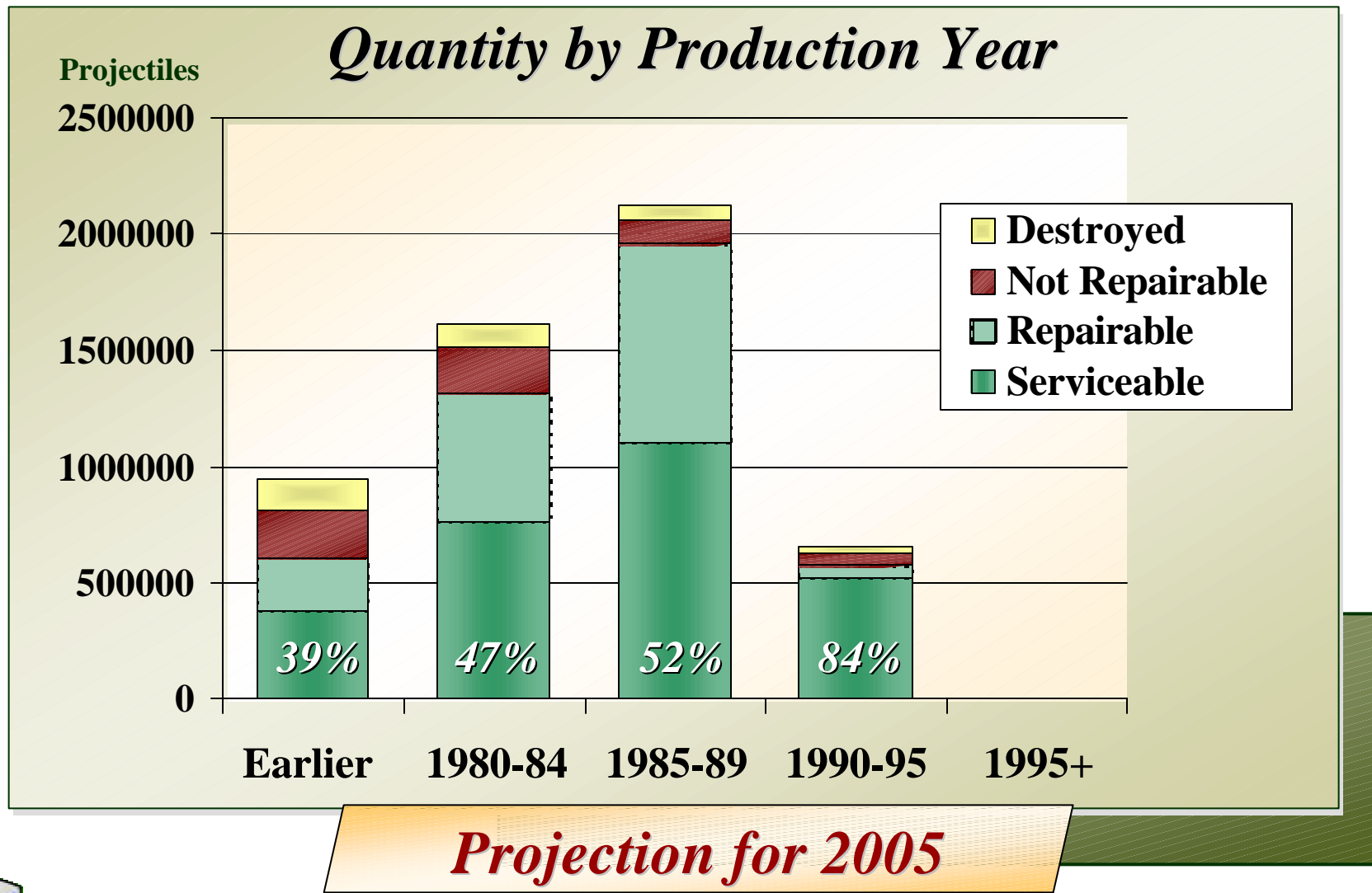

AMC-Army READINESS Command... Supporting Every Soldier Every Day

# Topics

---

- \* **Fuze Base Concerns**
- \* **Munitions FAA 2000**
- \* **Aging Stockpile**
- \* ***Recapitalization***
- \* **Army Procurement**
- \* **Fuzes in Production / Procurement**
- \* **Thoughts I Want to Leave You With**
- \* **Thoughts to Take Away**



# Recapitalization

- \* Returns Ammo to “Zero Hours” Standard - Upgrade w/Technical Enhancements, Repairs, Shelf Life Extension*
  - \* Improve Existing Stockpile*
  - \* Technology Insertion (i.e. Self-destruct Fuze)*
  - \* Offset Demil Costs (Estimated Cost \$78M)*
- 



# Recapitalization - - - Examples

- \* *Self-Destruct Fuzes on M864 DPICM's*
  - \* *Convert M483's Into M864's w/Self-Destruct Fuzes*
  - \* *R&D \$ for Low Cost Competent Munitions (LCCM) to Increase Effectiveness and Reduce Logistics Footprint*
  - \* *LCCM Fuze on DPICM*
- 



# Topics

---

- \* **Fuze Base Concerns**
- \* **Munitions FAA 2000**
- \* **Aging Stockpile**
- \* **Recapitalization**
- \* ***Army Procurement***
- \* **Fuzes in Production / Procurement**
- \* **Thoughts I Want to Leave You With**
- \* **Thoughts to Take Away**



# Near Term Procurement Ammunition, Army

## Army Budget

(\$ in Millions)

APPROPRIATION	FY00	FY01
FAMILY HOUSING	1,142	1,188
MIL PERSONNEL	27,934	28,373
RDTE	5,245	6,298
MCA	1,573	1,300
OMA	26,946	23,827
<b>PROCUREMENT</b>	<b>9,443</b>	<b>11,005</b>
ERA		390
BRAC	144	280
CHEM DEMI	1,023	980
AWCF	62	
<b>TOTAL*</b>	<b>73,510</b>	<b>73,641</b>

*\*Totals may not add due to rounding*

## Procurement Appropriation

(\$ in Millions)

APPROPRIATION	FY00	FY01
AIRCRAFT	1,507	1,561
MISSILES	1,309	1,311
WTCV	1,712	2,455
<b>AMMUNITION</b>	<b>1,193</b>	<b>1,212</b>
OTHER PROCUREMENT	3,722	4,466
<b>TOTAL</b>	<b>9,443</b>	<b>11,005</b>

**...OR PUT ANOTHER WAY...** 



AMC-Army READINESS Command... Supporting Every Soldier Every Day

# Near Term Procurement Ammunition, Army

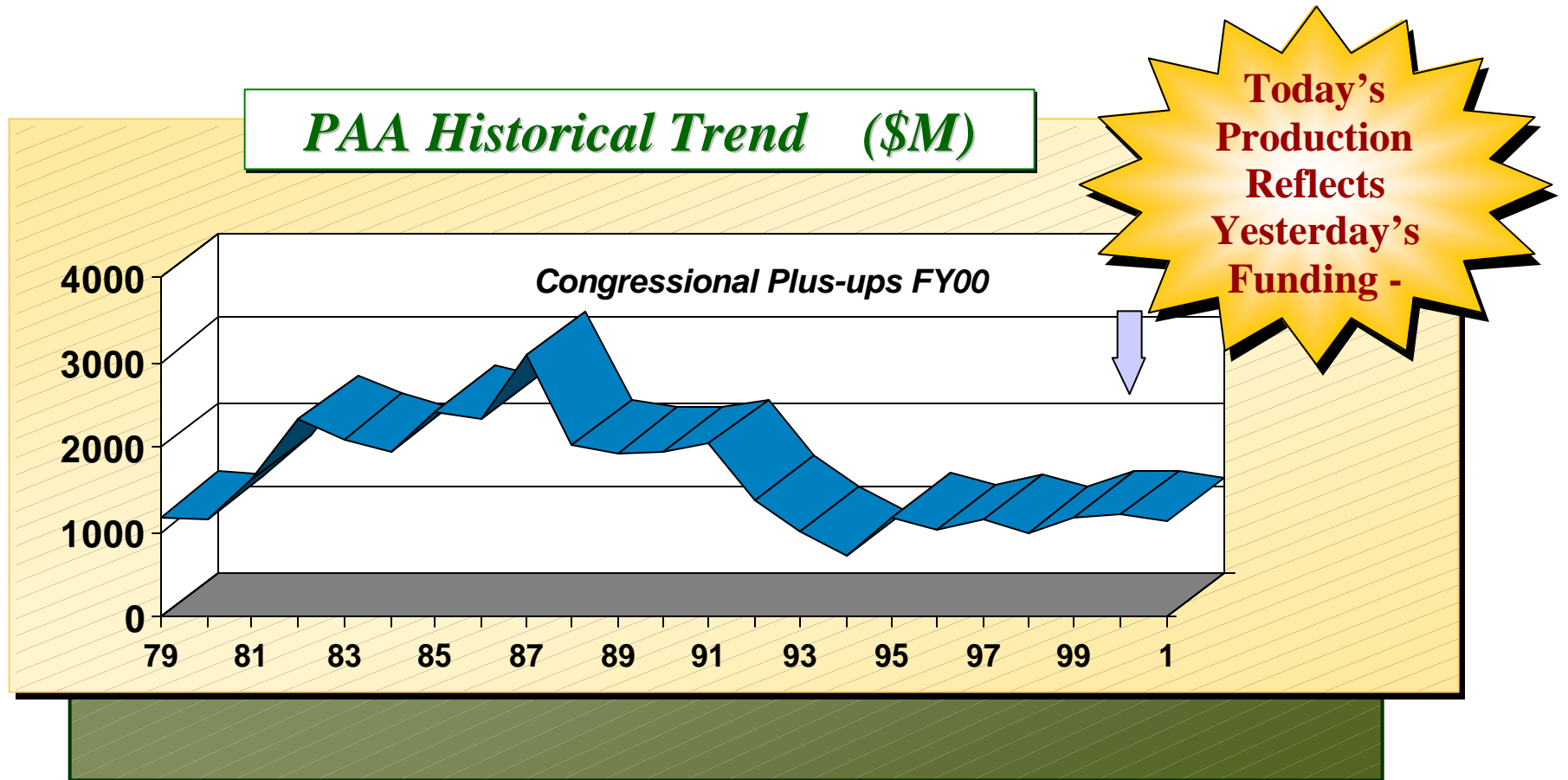

# Who Executes These Dollars

PAA

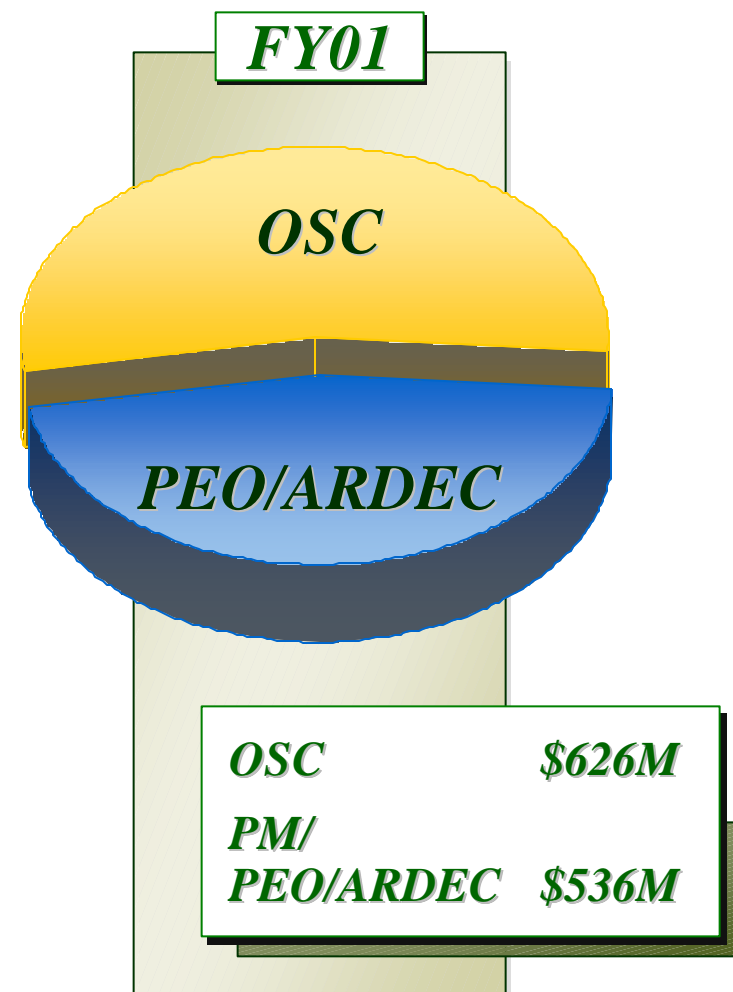
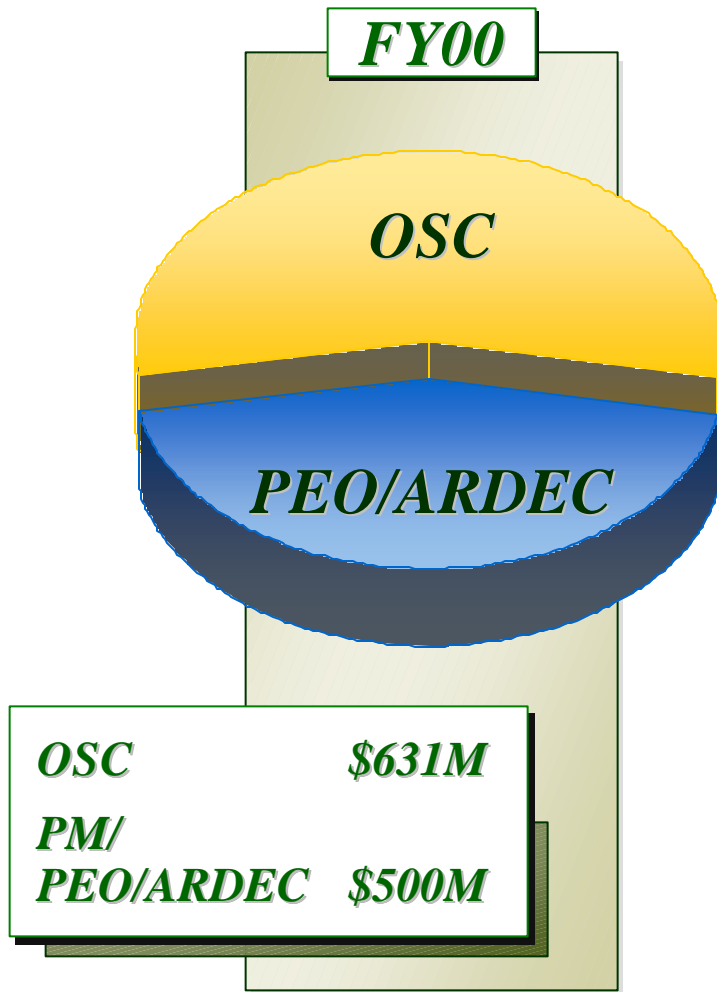

# Where the Money Goes

GOCO vs COCO vs Other

**FY96 - FY98**

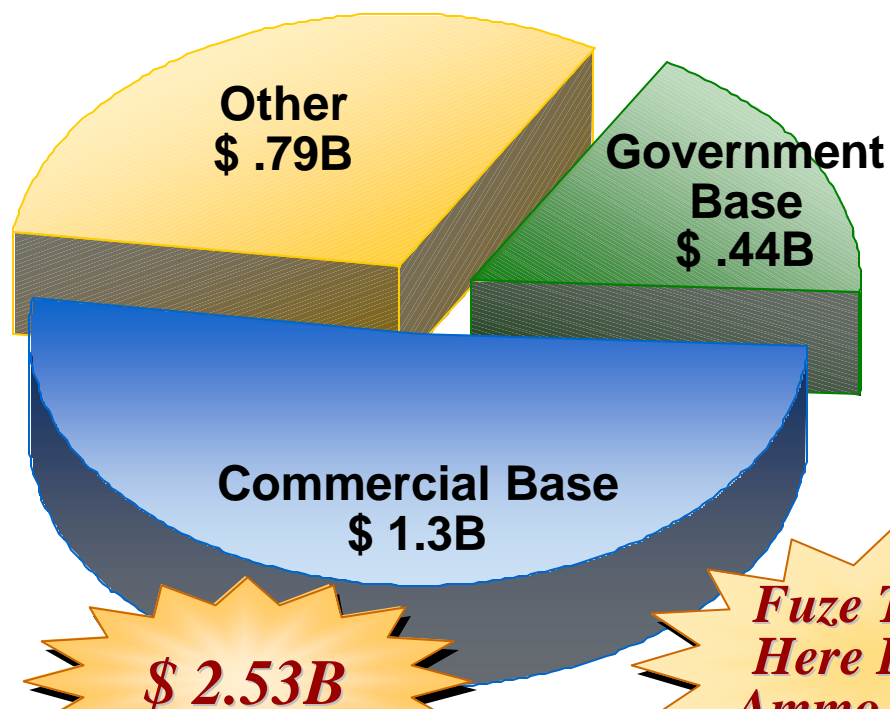

**FY99 - FY03**

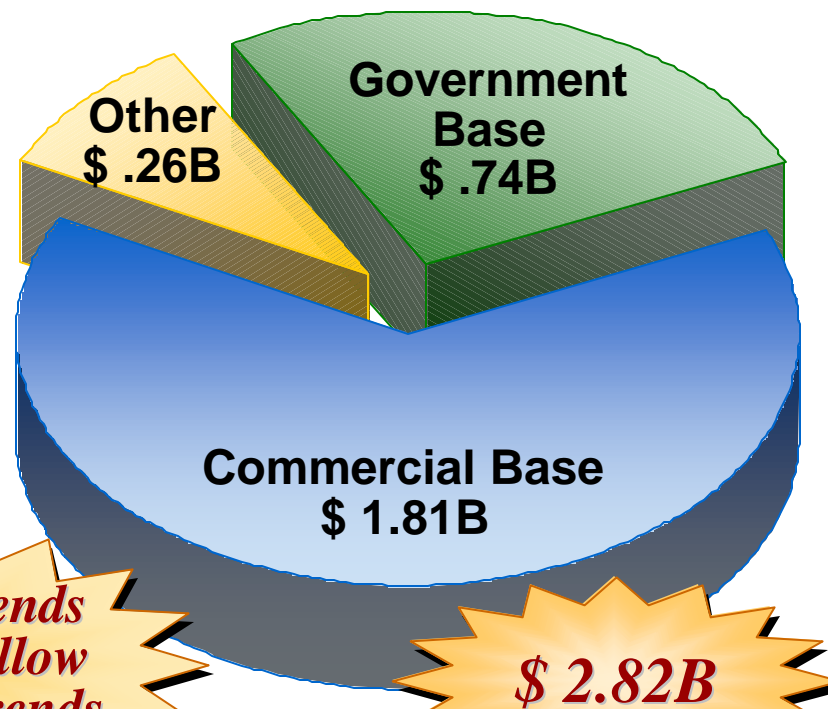

*Fuze Trends  
Here Follow  
Ammo Trends*

**Hardware Costs**



AMC-Army READINESS Command... Supporting Every Soldier Every Day

# Topics

---

- \* **Fuze Base Concerns**
- \* **Munitions FAA 2000**
- \* **Aging Stockpile**
- \* **Recapitalization**
- \* **Army Procurement**
- \* ***Fuzes in Production / Procurement***
- \* **Thoughts I Want to Leave You With**
- \* **Thoughts to Take Away**



# Fuzes In Production FY 02-03

---

- \* *M762A1 & M767A1 ET Fuzes for Artillery*
  - \* *M782 Multi-Option Fuze for Artillery (MOFA)*
  - \* *M734A1 Multi-Option Fuze for Mortars*
  - \* *M776 MTSQ Fuze for 120mm Mortar*
  - \* *M775 Mortar Practice Fuze*
  - \* *M783 PD Fuze for Mortars - TC in June*
  - \* *Grenade Fuzes - M213, M218, M228*
- 



# Fuze Procurement by Categories

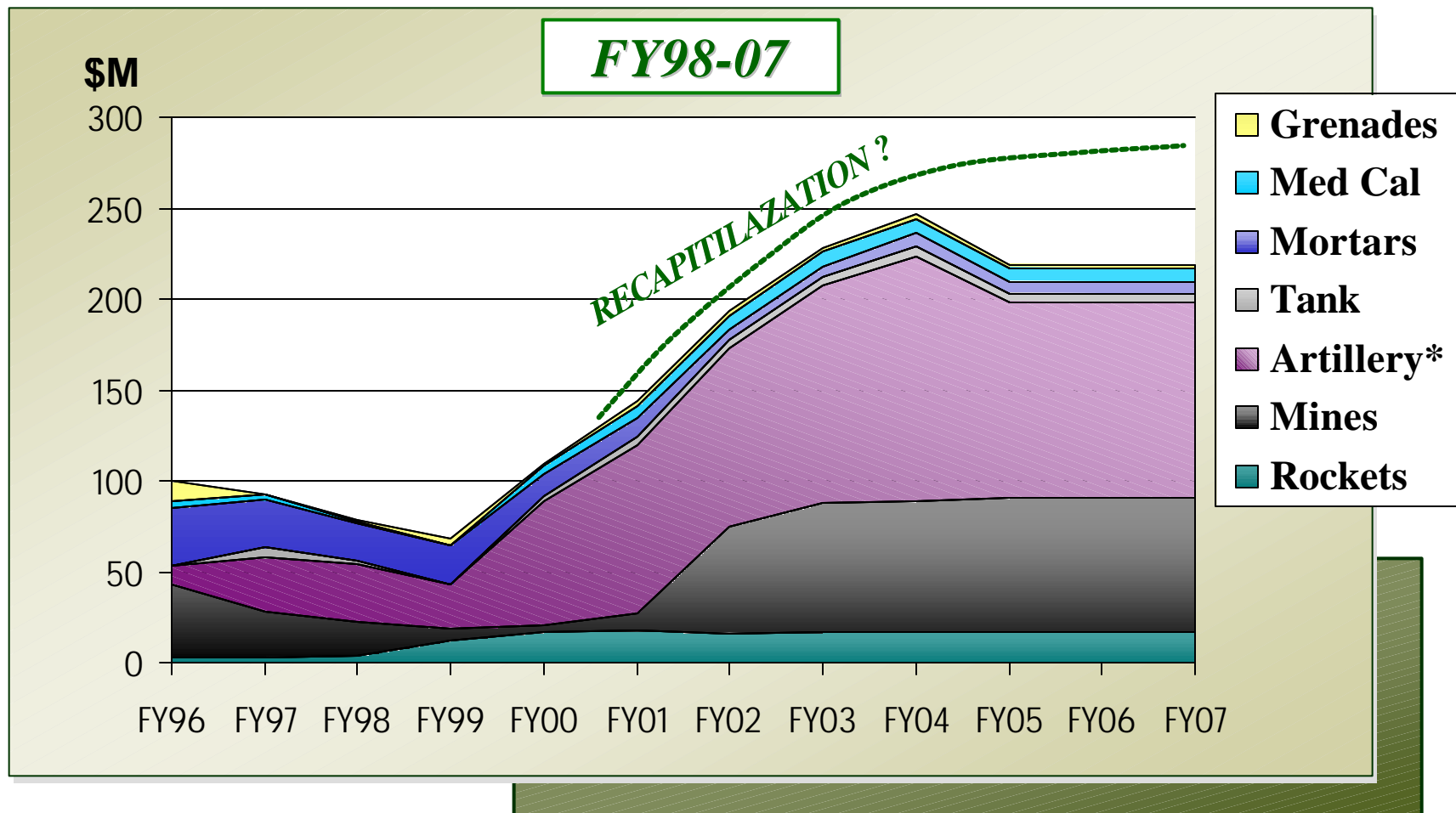

# Topics

---

- \* **Fuze Base Concerns**
- \* **Munitions FAA 2000**
- \* **Aging Stockpile**
- \* **Recapitalization**
- \* **Army Procurement**
- \* **Fuzes in Production / Procurement**
- \* ***Thoughts I Want to Leave You With***
- \* **Thoughts to Take Away**



# Thoughts I Want to Leave You With

————— Today: —————

✓ *Recapitalization Impacts Program Priorities*

✓ *Ammo Program Is Showing Positive Trends*

- Costs Are Reduced
- Improved Contracting Methods - Fixed Price, Multi-Year... Stabilizes Buys

✓ *Fuze Production Trend Up*

- Multi-year programs on M762A1/M767A1 and MOFA Fuzes

✓ *Increase Fuze Tech Base Funding above the current level of \$2M*

✓ *Fuze Workshop at Picatinny on May 8, 9 & 10*

# Topics

---

- \* **Fuze Base Concerns**
- \* **Munitions FAA 2000**
- \* **Aging Stockpile**
- \* **Recapitalization**
- \* **Army Procurement**
- \* **Fuzes in Production / Procurement**
- \* **Thoughts I Want to Leave You With**
- \* ***Thoughts to Take Away***



# Thoughts to Take Away

---

- \* The First Battle Is Logistics Readiness . . .  
We Are Fighting It Now*
  - \* Army Must Have a Logistics Overmatch  
(We Are the 9th Largest Army in the World)*
  - \* A Strong & Ready Army Requires a  
Partnership With A Strong & Ready Industry*
- 



# U.S. Army Materiel Command

COL(P) Vincent Boles

Deputy Chief of Staff for Ammunition

**Ammunition Update  
to 45th NDIA  
Fuze Conference**

**17 April 2001**



***AMC-Army READINESS Command... Supporting Every Soldier Every Day***

# **A Viewpoint from OSD**



**Anthony J. Melita**  
**Deputy Director**  
**Strategic and Tactical Systems,**  
**Munitions**

OUSD (AT&L)/S&TS, M  
Room 3B1060  
3090 Defense Pentagon  
Washington, DC 20301-3090

(703) 695-1382  
DSN 225-1382  
Fax (703) 614-3496  
E-Mail:Anthony.Melita@osd.mil

# Outline

- DoD Organization
- Funding Trends
- SecDef Submunition Reliability Policy
- NATO STANAGs vice MIL-STDs
- Conclusions

# DoD Organization

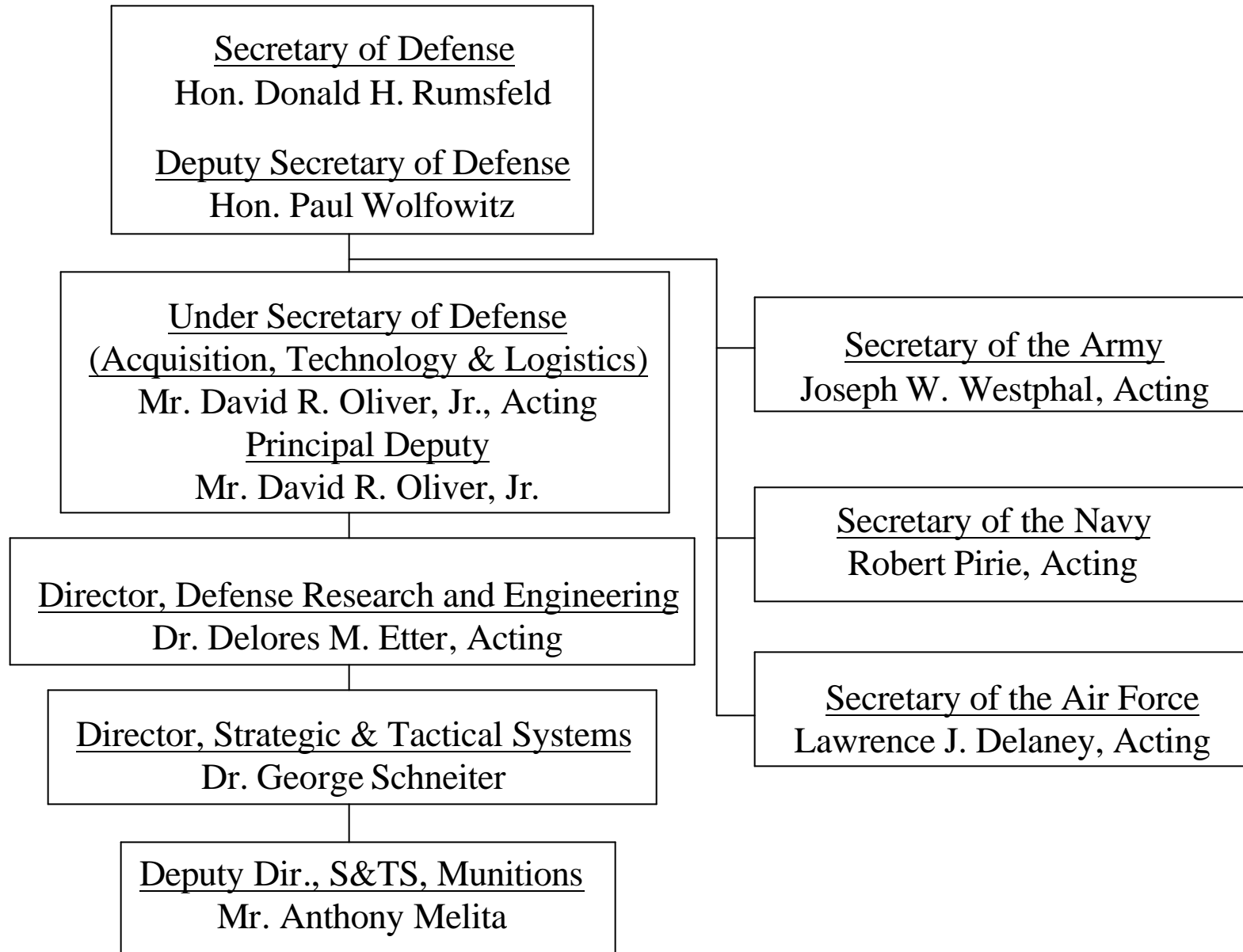

# DoD Munitions RDT&E and Procurement (Stacked Area)

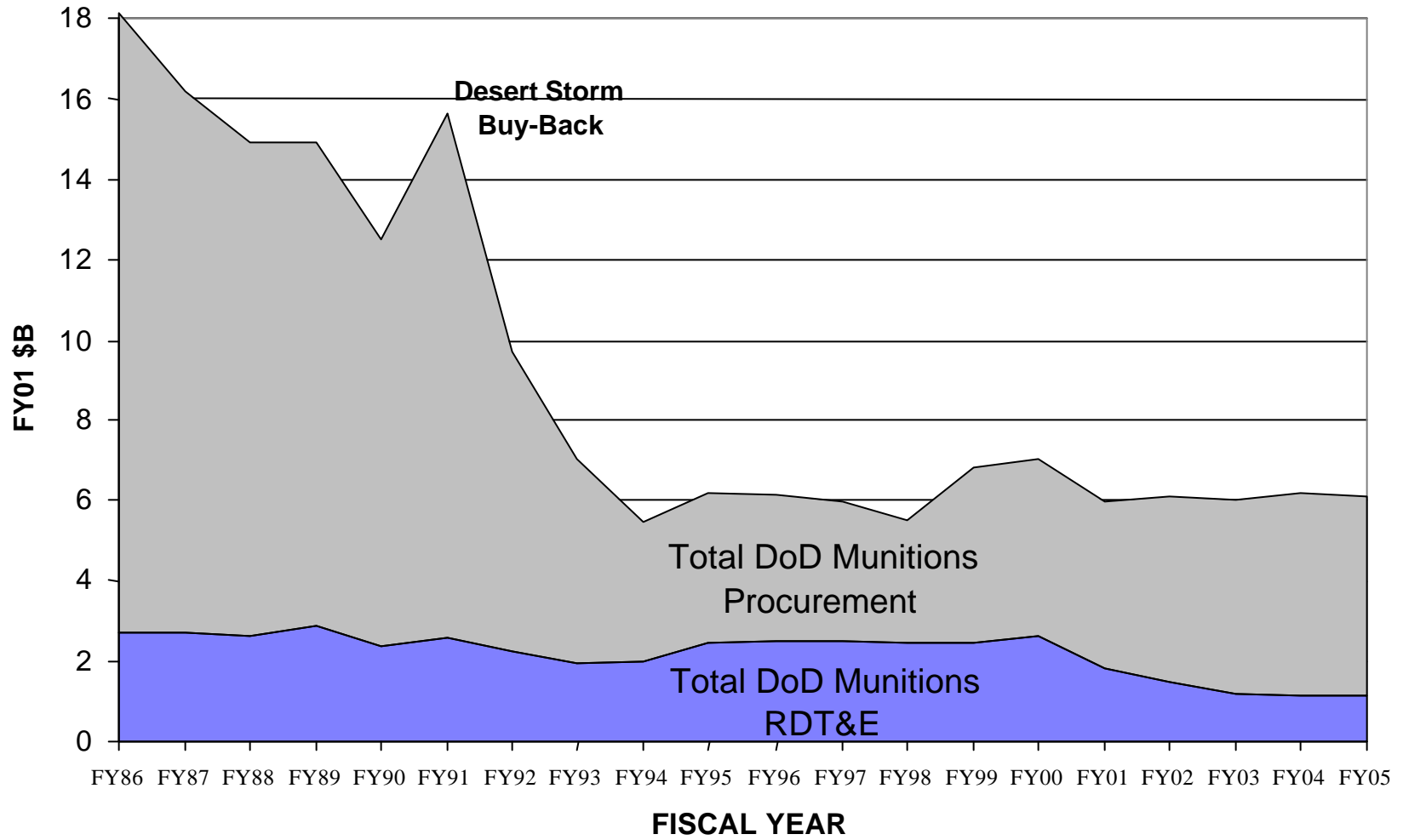

# FISCAL TRENDS

## Total Munitions and Fuze Procurement

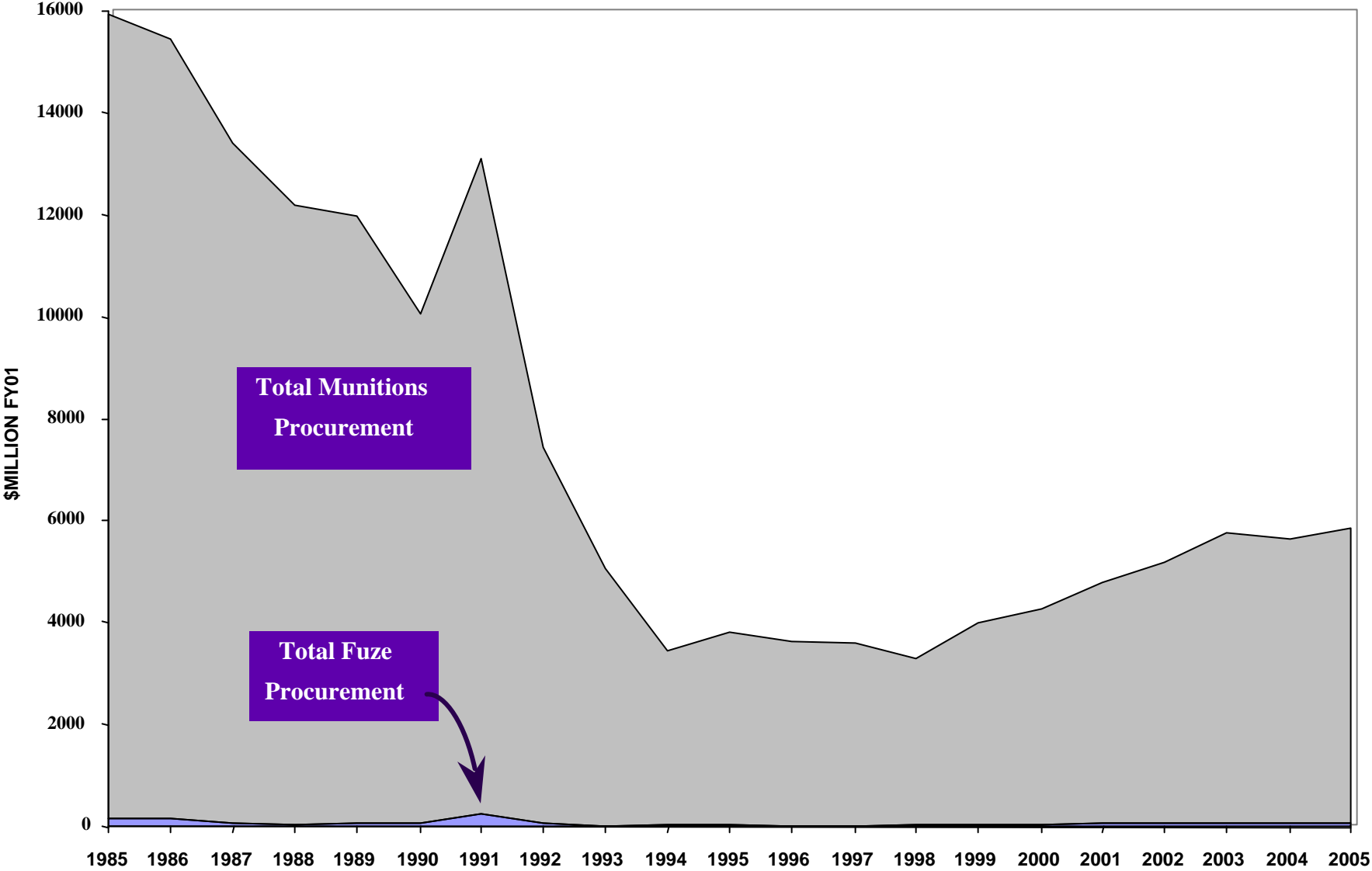



# **SecDef Submunition Reliability Policy**

**Secretary Cohen, January 10, 2001:**

**Issue:** Submunition weapons employed in Southwest Asia and Kosovo, and major theater war modeling, have revealed a significant unexploded ordnance (UXO) concern.

**Policy:** To reduce overall UXO through a process of improvement in submunition system reliability-the desire is to field future submunitions with a 99% or higher functioning rate. Submunition functioning rates may be lower under operational conditions due to environmental factors such as terrain and weather.

# SecDef Submunition Reliability Policy

- Basis for new defense guidance
  - Increases combat effectiveness
  - Enhances safety of friendly forces during combat operations
  - Enhances safety of peacekeepers and civilians in post-conflict environments

# SecDef Submunition Reliability Policy

- *Timetable for replacement/improvement*

- *Two Categories of Submunitions*

- Legacy - Active prior to 1st Qtr FY 2005
- Future Generation - Milestone III after 1st Qtr FY 2005

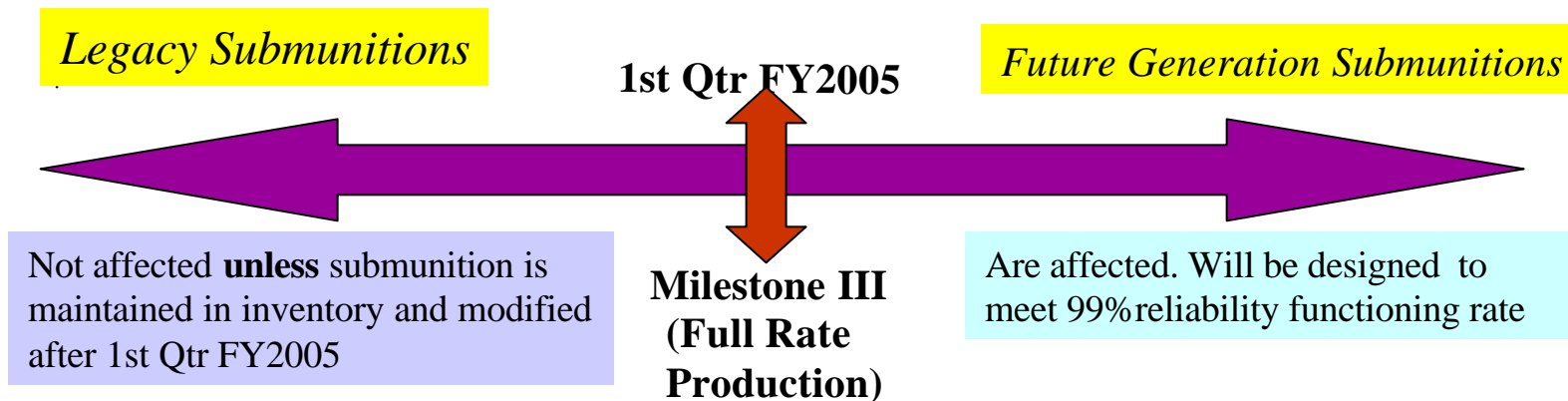

# SecDef Submunition Reliability Policy

Affected Weapons(Milestone III by 1QFY05 and beyond)

- Extended Range Guided Munition (ERGM) - XM80 Submunition
- 155mm XM982 Projectile (Excalibur) - M80 Submunition
- Guided-Multiple Launch Rocket System (G-MLRS) - M77 or M85 Submunition
- 2.75” HYDRA-70 Rocket - M73 Submunition
- Joint Standoff Weapon (JSOW) - BLU-97 Submunition

# SecDef Submunition Reliability Policy

- There is no intent to retrofit the existing submunition weapons inventory.
- Why a 99% reliability rate? - - because technology to achieve a 100% submunition functioning rate is not available at this time - - technology challenges remain both in the product development and manufacturing processes.

# **SecDef Submunition Reliability Policy**

- USD(AT&L) will enforce of this policy for now.
- This policy guidance will be included in the next update of the DoD 5000 series.

# **NATO STANAGs vice MIL-STDs**

## **USD(AT&L) , September 2000:**

- Use internationally recognized commercial and/or NATO Standards
- Incorporate into munitions system acquisition programs
- Eliminate U.S. equivalents

# Conclusion

- Fuze funding trends are bleak - Policy should have a positive effect
- Policy is to reduce overall UXO through a process of improvement in submunition system reliability-the desire is to field future submunitions with a 99% or higher functioning rate.
- Policy will be monitored by USD(AT&L) for now - will be included in the next update of the DoD 5000 series.