

COMPARISON OF INTERNAL ADAPTATION OF FIXED RESTORATIONS
FABRICATED
FROM FOUR DIFFERENT MATERIALS BY A THREE-AXIS MILL

by

Bryan Paul Rasmussen
Lieutenant Commander, Dental Corps
United States Navy

A thesis submitted to the Faculty of the
Prosthodontics Graduate Program
Naval Postgraduate Dental School
Uniformed Services University of the Health Sciences
in partial fulfillment of the requirements for the degree of
Master of Science
in Oral Biology

June 2016

Naval Postgraduate Dental School
Uniformed Services University of the Health Sciences
Bethesda, Maryland

CERTIFICATE OF APPROVAL

MASTER'S THESIS

This is to certify that the Master's thesis of

Bryan Paul Rasmussen

has been approved by the Examining Committee for the thesis requirement
for the Master of Science degree in Oral Biology at the June 2016 graduation.

Research Committee:



CAPT Glen Imamura, DDS, MS
Research Dept.
Research Committee Chair

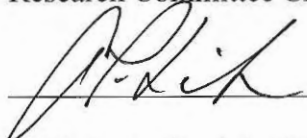

CDR Anton Petrich, DDS, MS
Prosthodontics Dept.
Program Director

The author hereby certifies that the use of any copyrighted material in the thesis manuscript titled:

COMPARISON OF INTERNAL ADAPTATION OF FIXED RESTORATIONS FABRICATED
FROM FOUR DIFFERENT MATERIALS BY A THREE-AXIS MILL
is appropriately acknowledged and, beyond brief excerpts, is with the permission of the copyright
owner.

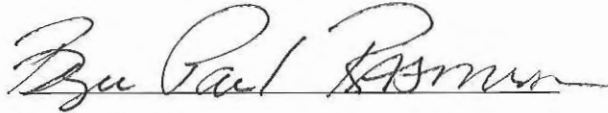

Bryan Paul Rasmussen
Prosthodontics Graduate Program
Naval Postgraduate Dental School
26JUN2016

NAVAL POSTGRADUATE DENTAL SCHOOL
BRYAN PAUL RASMUSSEN

2016

This thesis may not be re-printed without the expressed written permission of the author.

ABSTRACT

COMPARISON OF INTERNAL ADAPTATION OF FIXED RESTORATIONS FABRICATED FROM FOUR DIFFERENT MATERIALS BY A THREE-AXIS MILL

LCDR Bryan Paul Rasmussen, DC USN
Prosthodontics Dept., 2016

Directed by: Glen Imamura, Chairman Research Department
Naval Postgraduate Dental School

Introduction: Internal adaptation is the space between the restoration and tooth preparation.

Nakamura reported the closer the adaptation between a ceramic restoration and its abutment, the greater a crown's resistance to fracture. Ideal internal adaptation is as minimal as possible while still allowing for complete seating of the restoration. **Objective:** This study compared the internal adaptation of maxillary anterior crowns milled from four different materials on a 3-axis milling machine. It was hypothesized there would be no difference between the test groups. **Method:** A digital impression of a maxillary central incisor prepared for an all ceramic crown was used to produce 40 standardized dies using stereo lithography. Lithium disilicate, zirconia, feldspathic porcelain, and polymethyl methacrylate (N=10) restorations were milled (Sirona MC XL), crystallized, and sintered following manufacturer's specifications. The restorations were cemented to the dies, encased in stone, and sectioned in a mid-coronal plane. The sections were sequentially polished and evaluated using digital microscopy (Hirox KH-7700, Digital Microscope and software) at 35x magnification. The internal adaptation at 25 incisal, facial and lingual locations were measured with the software measurement tool. **Results:** One-way ANOVA revealed no significant differences in internal adaptation between restorative materials ($p=0.074$). One-way ANOVA found a highly significant difference in internal adaptation between the surfaces

($p < 0.001$). A Tukey HSD post hoc test found highly significant differences between incisal and facial ($p < 0.001$), incisal and lingual ($p < 0.001$) and facial and lingual ($p = 0.002$) surfaces.

Conclusion: This study suggests differences in the milling process of the various materials did not affect internal adaptation. Significant differences were found at the locations where the milling was performed.

TABLE OF CONTENTS

LIST OF TABLES AND GRAPHS		6
LIST OF FIGURES		7
CHAPTER		
I.	INTRODUCTION	8
II.	REVIEW OF THE LITERATURE	11
	PRINCIPLES OF TOOTH PREPARATION.....	11
	RETENTION FORM.....	11
	RESISTANCE FORM.....	12
	MAXILLARY ANTERIOR INCISOR PREPARATION.....	14
	INTERNAL ADAPTATION.....	15
	CAD/CAM TECHNOLOGY.....	16
	HISTORY OF CERAMICS IN DENTISTRY	18
	A. FELDSPATHIC	18
	B. LEUCITE REINFORCED.....	18
	C. LITHIUM DISILICATE.....	19
	D. ZIRCONIA	22
	E. POLYMETHYL METHACRYLATE.....	23
	SUMMARY.....	23
III.	MATERIALS AND METHODS.....	25
IV.	RESULTS	33
V.	DISCUSSION.....	36
VI.	CONCLUSIONS.....	39
REFERENCES		40

LIST OF TABLES AND GRAPHS

Table	Page
1. Data for internal adaptation evaluated by material	34
2. Data for internal adaptation evaluated by surface.....	35
3. Data for internal adaptation evaluated by surface and material	37

Graph	Page
1. Mean internal adaptation by material	34
2. Mean internal adaptation by surface.....	35
3. Mean internal adaptation by material and surface	37

LIST OF FIGURES

Figure	Page
1. Cross-section of putty index	25
2. Preparation guide for IPS e.max anterior crown preparation	25
3. Preparation from the original crown	26
4. Putty base with notches for orientation.....	26
5. Shows how sensors calculate the distance to an object	26
6. Digital scan of the die with preparation design	27
7. The indexed framework and the manufactured die.....	27
8. Ideal thickness for an IPSe.max all ceramic restoration.	28
9. Restoration milled out using Sirona MC XL	28
10. Seating jig for luting restoration to manufactured die	30
11. Cross section of sectioned restoration encased in dental stone.....	30
12. The point used for initial alignment.....	31
13. Radial screen; distance between each ring is equivalent to 0.25 mm.....	31
14. Shows separation line of incisal surface to the lingual and facial	32
15. Measurements as seen on the Hirox screen	32
16. Facial and profile view of die	38

CHAPTER 1: INTRODUCTION

Metal-ceramic restorations have been the gold standard for single-tooth cemented restorations.¹ These types of restorations were initially developed in the 1960's from porcelains that possessed a coefficient of thermal expansion/contraction compatible with the metal substructures they were fired upon.² Metal-ceramic restorations exhibit several disadvantages. These include metal showing through the porcelain veneer if there is insufficient tooth reduction; reflected light from the metal substructure can cause a dark hue which appears above the gingival margin; and decreased biocompatibility when compared to all-ceramic restorations.³ As esthetic awareness of the public has increased the use of all-ceramic restorations that reduce some of the esthetic complications from metal ceramics.⁴ In the past 25 years, advancements in dental ceramic materials, manufacturing techniques, and computer aided design/computed aided manufacturing (CAD/CAM) have further increased the use of all-ceramic fixed restorations.¹ Today's dental ceramics better mimic the appearance of natural teeth.¹ All-ceramic fixed restorations have proven to be long lasting. However, when they fail, the reasons include ceramic fractures, fracturing of the overlying material, secondary caries, tooth root fractures, and failures of retention.³ Typically, when one uses stronger materials, esthetics are compromised. Alternatively, if strength is desired, resistance to fracture is reduced. A challenge in prosthetic dentistry is to balance restoration strength with esthetics.²

All-ceramic restorations have become the material of choice for fixed restorations.⁵ In 2008, 50% of fixed restorations produced were all-ceramic, which was a large increase from the previous year.⁶ Glidewell, the largest dental laboratory in the United States, reported in 2007 that 65% of the single-unit fixed restorations were metal-ceramic, and in 2012 only 20% of the restorations manufactured in their laboratory were metal-ceramic.⁷ There is no indication that the trend will reverse.⁶ New technologies have been developed to produce all-ceramic restorations,

including: slip casting, CAD/CAM, and heat pressing of the ceramics.⁵ Single and multiple fixed prostheses have been milled from manufactured blocks of porcelain for 20 years.³ Advancements in CAD/CAM technology in dentistry and improved materials have proved a synergistic combination.²

Schaefer et al. stated that internal fit and marginal fit of fixed restorations to the tooth preparation are important criteria requiring careful evaluation.⁸ Poor restorative adaptation can lead to microleakage, increased plaque retention, cement breakdown, tooth discoloration, secondary decay, and pulpitis.^{8,9} Internal fit is a clinically relevant topic affecting the strength of a fixed restoration-cement system.¹ A uniform internal fit mitigates compromised retention or resistance form and provides an appropriate luting space.^{5,10}

Internal fit can vary significantly. Discrepancies between the inner surface of a ceramic restoration and the abutment tooth can vary from as little as 24 μm to as great as 634 μm using the same manufacturing system.¹¹ The optimum internal space necessary for a luting agent ranges from 20 to 40 μm .⁵ Fixed restorations with smaller internal fit dimensions along the axial wall and at margin areas demonstrate higher compressive strength.⁹ Fixed restorations with poor internal adaptation show decreased fracture resistance.⁹ Nakamura et al. reported the greater the adaptation between a ceramic restoration and abutment tooth, the stronger a crown's resistance to fracture can be.¹² If the luting space is large, fracture strength and longevity can be affected.⁴ Colpani et al. reported internal fit dimensions greater than 70 μ reduced crown fracture resistance.¹ Similarly, May et al demonstrated cement thicknesses ranging from 50-100 μm withstood twice the amount of force when compared to cement thicknesses of 300-500 μm .¹¹

The internal fit of all-ceramic fixed restorations is not well controlled by some manufacturing methods.¹¹ A consistent cement space of 20 to 40 μm is difficult to achieve with milled manufacturing systems. Cement spaces ranging from 100 to 150 μm ,⁴ 50 to 100 μm ⁵ and

200 and 300 μm^5 have been deemed clinically acceptable for milled restorations that have sufficient ceramic thickness and do not affect the lifespan of the restoration.¹³

May et al., mentioned there is not an accepted and consistent means to evaluate the fit of fixed restorations, though there are many methods to evaluate.¹¹ Published methods evaluating the internal fit of fixed restorations include: laser videography, profile projector, micro-CT, CAD/CAM scanner, replica technique, and cement analog technique.¹ Schaefer et al. have recommended further studies to evaluate different impression procedures and cast fabrication techniques on the adaptation of ceramic restorations to restorative preparations.^{8,10}

CHAPTER II: REVIEW OF THE LITERATURE

A search was made of current and historical literature on the following key terms: tooth preparation, resistance form, anterior tooth preparation, dental porcelain, all-ceramic restorations, internal adaptation, CAD/CAM, lithium disilicate, zirconia, feldspathic using PUBMED.

Literature was narrowed to specifically include lithium disilicate, all-ceramic restorations, tooth preparation form in regards to retention and resistance form, zirconia, internal adaptation, and literature that related to CAD/CAM technology. Literature relating specifically to anterior tooth preparations and the milling process related to fit, in regards to internal adaptation, for lithium disilicate and zirconia restorations was found to be lacking.

PRINCIPLES OF TOOTH PREPARATION

The basic principle of tooth preparation takes into account the biologic, mechanical, and esthetic demands of the tooth being restored. Biologic factors include pulpal and periodontal health, and conservation of tooth structure. Mechanical considerations take into account the structural durability of the tooth, masticatory forces applied, cement strength and weakness, as well as retention and resistance form of the preparation. Esthetic considerations are dependent on location in the arch, type of prosthesis fabricated, contour, tooth reduction, margin placement, as well as patient and doctor expectations.

RETENTION FORM

A crown is considered retentive if it can withstand a removal force along its path of insertion. According to Kaufman and colleagues,¹⁴ factors influencing retention in a prepared tooth include surface area, preparation height, angle of convergence, surface texture, intracoronal retention, and overall degree of retention provided by different components of the prepared area.

The authors concluded that retention increases as the opposing walls approach parallelism, and to a lesser degree, as height increases. Furthermore, there was a linear increase in retention as the preparation increased in diameter, with areas closer to the gingival termination providing the greatest contribution.¹⁴

Jorgensen studied retention form and its relationship to convergence angle using brass cones prepared at angles of 5°, 10°, 15°, 20°, 25°, 35°, and 45°. He concluded that the relation was hyperbolic.¹⁵ Retention was greatest at a convergence angle of 5° or less, but as the angle increased beyond 5°, retention dropped significantly.¹⁵ He also concluded that increased surface roughness improved retention.¹⁵ Goodacre and colleagues used optimum convergence angle to establish clinical feasibility.¹⁶ Their review of the literature concluded that a total occlusal convergence between 10 - 20° could be achieved by practitioners while retaining ideal retention.^{10,16}

RESISTANCE FORM

Shillingburg defined resistance as the ability of a tooth preparation to withstand dislodgement of the restoration by forces directed in an apical or oblique direction and prevents movement of the restoration under occlusal forces.¹⁷ Caputo and Standlee went so far as to state that preparation resistance form was the most important factor to insure restoration success.¹⁸

Parker and colleagues published a series of articles evaluating resistance form. They stated a preparation exhibits resistance form if axial walls of the preparation interfere with an arc of the casting pivoting about a point on the opposite side of the preparation.¹⁹ The location and orientation of this arc made it possible for a preparation to resist rotation in one direction, but not in another. For a tooth preparation to be clinically acceptable the preparation must resist rotation in all directions.¹⁹ In this article, they also discussed the “on-off” nature of resistance - for each

point there either is resistance, or there is not. Based on the arc of rotation and “on-off” they defined the concept of “limiting taper.”²⁰ The limiting taper is the average taper of a line perpendicular to a radius starting from any point of rotation on the preparation margin.²⁰ Therefore, if a point on the preparation has less than the limiting taper, the preparation exhibits resistance form. Any taper greater than the limiting taper will not provide resistance.²⁰

In a 1991 study, Parker and colleagues evaluated resistance form in prepared incisors, canines, premolars, and molars.¹⁹ In this study, they again mentioned “on-off” nature of resistance form.²¹ Resistance form is a discontinuous function in which there is an exact height preparations switch from having no resistance form, to having resistance form, and that it was determined by the limiting taper. For prepared teeth, they found 96% incisors, 92% canines, 81% premolars, and 46% molars had resistance form.¹⁹ In 1993, the group expounded on the “on-off” nature of resistance form and proposed an equation to determine limiting taper (T) equal to one-half the arcsine of height to base ratio [$T = \frac{1}{2} \arcsin(H/B)$].²⁰ The value of T established the standard of minimal preparation acceptability.²⁰ Using the formula, the limiting tapers were 29° for incisors, 33° for canines, 10° for premolars, and 8.4° for molars.²⁰

In a theoretical progression, an analysis of resistance form for dislodged restorations and retainers was done in 1997.²² A total of 44 dislodged castings were included; 28 molars, 15 premolars, and 1 incisor. Of the castings, all of the molars and 93% of the premolars lacked resistance form. Only 1 incisor and 1 other casting exhibited resistance form.²²

With the “on-off” concept, resistance form is tested simply with a “finger roll” of the crown off the die.²¹ If the crown easily rolls off the die with tipping pressure, it lacks resistance form.¹⁹ Various other methods to analyze resistance form were discussed by Parker in 2004.²³ He discussed laboratory studies evaluating resistance form.²³ Uneven margins can make a parallel walled preparation lack resistance form.²³ Methods to enhance resistance form include crown

lengthening, shoulder margins, proximal boxes or grooves, occlusal isthmus, pins or posts.^{10,19-21,23}

MAXILLARY ANTERIOR INCISOR PREPARATION

Parker et al. (1991) determined that 96% of incisors prepared for full coverage restoration exhibit adequate resistance form.¹⁹ A critical factor in assessing adequate incisor resistance form is a favorable occlusal-cervical (OC) to facial-lingual (FL) ratio. When prepared, an incisor's overall height compared to its width provides resistance form and the need for auxiliary features such as retentive grooves become unnecessary. Goodacre and colleagues¹⁶ determined the OC/FL ratio should be 0.4, or higher, for all teeth. They further stated that prepared maxillary central incisors, due to their position in the arch and considerable cervical convergence, require greater overall proximal reduction.¹⁶

Chiche²⁴ described the parameters of the ideal preparation for an all-ceramic anterior restoration in his textbook, *Esthetics of Anterior Fixed Prosthodontics*.²⁴ The ideal incisal reduction should range from 2 mm to one third the height of the anatomic crown.²⁴ This estimate takes into consideration incisal edge thickness. A thin incisal edge should be flattened and reduced for incisal support as long as it does not exceed 3 mm in reduction.²⁴ Short preparations are contraindicated for all-ceramic fixed restorations, even when luted with resin cements. Short preparations do not provide adequate support for the ceramic leading to porcelain flexure and fracture. Reduced preparation height decreases resistance form, subjecting the crown to tipping forces and dislodgement.²⁴

Margin design studies have shown that a shoulder finish line provides the greatest strength for all-ceramic restorations.²⁴ However, if the luting agent is a resin cement, laboratory studies indicate no significant strength reduction between a shoulder or chamfer finish line.¹⁶ It is not always in best interest to have a uniform margin thickness of 1.0 mm. A range, from 0.5 - 1.0 mm,

has been determined to be adequate for esthetics, conservation of tooth, strength, resistance, and support.^{17,24}

Preparation line angles should be smooth. Sharp internal line angles create foci of tensile stress that can cause fracture of the ceramic. Facial reduction should be at least 1.0 mm, and lingual reduction 1.0-1.3 mm (absolute minimum 0.8 mm) for adequate thickness of ceramic, esthetics, and material strength.^{10,24}

INTERNAL ADAPTATION

The retention of a restoration upon an abutment has been extensively explored in Prosthodontic literature. The thickness of the intervening cement layer was a readily observable means to evaluate this. In 1960 Jorgensen reported on four major factors affecting cementation; preparation taper, cement viscosity, available cement space, and placement force.²⁵ In 1968, Jorgensen and Esbensen evaluated the effect of film thickness and retention on fixed restorations. They found displacement of the restoration by cement reduced the retentive area with increasing film thickness. However, due to film thickness variation, the overall retention of the restoration was only moderately influenced.²⁶

Later investigations have refined this concept, resulting in publication of numerous articles evaluating marginal fit and internal adaptation. The majority of these reports expound on the role of marginal fit because it was easier to quantify than internal adaptation. An open space at the restorative margin is readily visible and unquestioned in regards to importance in the prevention of secondary caries, cement washout, and ultimate failure.¹⁷ Methodologies to measure crown adaptation varied between the studies. Investigators have used polyvinylsiloxane impression material to “lute” the crown to the die and then measure the thickness of the material.¹ Other studies favor cementation of the crown to the die to simulate the clinical situation.¹ Three-

dimensional internal fit mapping has also been employed to measure internal adaptation.²⁷

Holmes et al,²⁸ defined internal gap (adaptation) as the perpendicular measurement from the axial wall of the preparation to the internal casting surface. Controversy surrounds defining the ideal internal adaptation for ceramic restorations.^{29,30,31,32,33} Current literature supports acceptable fit discrepancies of 50 - 150 μm .^{34,35}

The internal adaptation size corresponds to the amount of cement between the tooth preparation and restoration and size is related to cement thickness. Tight fitting restorations, (restorations with minimal cement thickness) may show “vertical lift”.³⁶ In other words, the restoration does not completely seat. To address this, Wilson in 1994 stated increased axial space benefits seating. Internal etching of fixed restorations created space to improve pre-cementation seating and decrease “spring-back” of the crown after the seating force was removed.³⁷

Internal adaptation and its’ importance to restoration longevity is not as thoroughly covered. May et al. took the position that internal fit could be of greater importance when compared to marginal adaptation, especially in regard to the adhesive cementation of an all-ceramic restoration.¹¹ Their primary argument was all-ceramic restorations required uniformed support. If the internal fit, or as they termed “internal misfit” was large, a thick layer of low elastic modulus material (resin cement) could introduce tensile stresses as a result of polymerization shrinkage.¹¹ A limitation of CAD-CAM technology, especially early milling machines, resulted in over-milling of internal surfaces of restorations and therefore produced a larger internal cement space.^{10,11,38,35,33,39,40,41,42,29,43,44}

CAD/CAM TECHNOLOGY

Computer-aided Design (CAD) and Computer-aided Manufacturing (CAM) was introduced to dentistry by Dr. Duret in the 1970’s. He produced the first CAD/CAM restoration in

1983, and publically presented his system at the French Dental Association's International Congress in November 1985.⁴⁵ Around the same time, Dr. Mormann developed a CAD/CAM system with the assistance of an electrical engineer, Dr. Brandestini, and software designer Dr. Ferru. They created CEREC (Computer-assisted CEramic REConstruction). On September 19, 1985 they milled the first chairside ceramic restoration at the University of Zurich Dental School. CEREC 1 became commercially available by 1989. The introduction of CEREC 3 in 2000 was a technologic leap over the previous two systems. It incorporated a 2-bur system, with a "step bur" that reduced the diameter of the cylindrical bur. The smaller diameter tip enabled higher precision form-grinding, and had a reasonable bur life.⁴³ CEREC 3 possessed the capability to mill inlays, onlays, half fixed restorations, three-quarter crowns, and complete fixed restorations. Additionally, a direct optical impression system was made available.^{46,47}

The claimed advantages of CAD/CAM dentistry include speed, ease of use, digital imaging, and improved quality. An on-site milling machine makes it possible for patients to leave the same day with a final restoration. It eliminates fabrication of provisional restorations and return appointments. A library of digital images allows for quick fabrication in the future should a restoration be lost, or if neighboring teeth require restoration. Improvements to this technology are constant. A drawback of CAD/CAM technology is the frequent release of software updates, which increase operating costs and require time to learn newer software.⁴⁵

CAD/CAM technology is part of the future of dentistry. Because of its advantages, more materials are being developed for compatibility with the milling systems. Available materials include: monolithic feldspathic ceramic, leucite-reinforced glass-ceramic, lithium disilicate glass-ceramic, zirconia, polymethyl methacrylate, as well as composite resin blocks.^{10,48}

HISTORY OF CERAMICS IN DENTISTRY

A. Feldspathic

There are a variety of ceramic materials available for all-ceramic single fixed restorations. However, each has limitations in the oral environment. A ceramic contains metallic and non-metallic elements that form a hard, stiff, and brittle material due to their inter-atomic bonding.⁴⁹ Dental ceramics consist of glasses, porcelains, glass-ceramics, or highly crystalline structures; the amounts of which vary in the different products.⁴⁹ Ceramics are corrosive resistant, biocompatible, stable, strong, temperature-resistant, and resilient which make them desirable in dental applications.⁴⁹ However, they are brittle and may fracture when subjected to tensile forces, or rapid changes in temperature.⁴⁹ Feldspathic porcelain has been available for use in dentistry for over forty years. It consists of either potassium or sodium feldspar, with alumina and silica components suspended in a glassy matrix.⁴⁹ Feldspar has a tendency to form the crystalline mineral leucite when heated. Leucite is a potassium-aluminum-silicate, with a large coefficient of thermal expansion, compared to feldspathic glass.⁴⁹ This is an advantage when used for metal-ceramic restorations, as it improves metal bonding of the ceramic. Leucite is also added to ceramics to control thermal contraction.⁴⁹

B. Leucite Reinforced

In 1968, MacCulloch first used a glass-ceramic in dentistry.⁵⁰ Glass-ceramics differ from porcelain in that during heat treatment, or *ceramming*, the glassy structure undergo crystallization. The crystals formed during the *ceramming* process interrupt crack propagation, resulting in stronger and tougher restorations.⁴⁹ These materials could be used in a pressure molding technique to form fixed restorations from a lost-wax pattern.⁴⁹ IPS Empress was one of the first glass-

ceramics available that could be heated and pressed into a mold. It contained a higher concentration of leucite crystals that resisted crack propagation when compared to feldspathic porcelains. Feldspathic porcelain had a flexural strength of 80 ± 10 MPa, a coefficient of thermal expansion of $12.8\times 10^{-6}\text{K}^{-1}$, modulus of elasticity of 69.4 GPa, and fracture toughness of $0.84\text{--}0.96$ $\text{MPa}\cdot\text{m}^{0.5}$. Leucite-based IPS Empress had a flexural strength of 160 MPa, coefficient of thermal expansion of $16.6\times 10^{-6}\text{K}^{-1}$, modulus of elasticity of 62 GPa, and a fracture toughness of 1.3 $\text{MPa}\cdot\text{m}^{(0.5)}$.^{10,51}

C. Lithium Disilicate

In 1998, Ivoclar introduced IPS Empress 2, a lithium disilicate ($\text{Li}_2\text{Si}_2\text{O}_5$) based glass-ceramic. It was claimed to be a high strength and highly esthetic glass-ceramic, and could be used for three-unit fixed dental prostheses. IPS Empress 2 had a predominant crystalline phase of lithium disilicate with a lower volume of lithium orthophosphate crystals.^{51,52} Elongated lithium-disilicate crystals formed an interlocking structure to improve elastic modulus over leucite-based IPS Empress 1. The interlocking crystal structure hindered crack propagation. If cracks were present, fiber-like crystals would trap them, imparting crack growth resistance and resulting in higher reliability and higher Weibull modulus.⁵³ IPS Empress 2 had greater flexural strength (400 ± 40 MPa) and fracture toughness (3.3 ± 0.3 MPa) compared to IPS Empress 1. It had a coefficient of thermal expansion of $10.6\pm 0.25\times 10^{-6}\text{K}^{-1}$.^{49,54}

In 2005, Ivoclar introduced an improved lithium disilicate glass-ceramic, IPS e.maxPRESS. IPS e.maxPRESS was developed with smaller crystals to increase flexural strength, improve fracture toughness by 10%, and provide greater translucency compared to IPS Empress 2.⁵⁵ In 2006, Ivoclar introduced IPS e.maxCAD, a monolithic block for use in milling units. IPS e.maxCAD is available in a partially crystallized, or “blue”, state and contains lithium metasilicate

crystals (Li_2SiO_3). The physical properties of fully crystallized lithium disilicate make it difficult to mill. The partially crystallized “blue” state is softer and can be machined without excessive bur wear or damage to the material.⁴⁸ Following the milling procedure the restorations are heat tempered. The formation of lithium disilicate imparts the final shade and desired physical properties. IPS e.maxCAD has a slightly lower flexural strength of 360 ± 60 MPa compared to IPS e.maxPRESS (400 ± 40 MPa). It also has a lower fracture toughness of $2.0\text{-}2.5 \text{ MPa} \cdot \text{m}^{(0.5)}$ compared to IPS e.maxPRESS ($2.5\text{-}3.0 \text{ MPa} \cdot \text{m}^{(0.5)}$). The modulus of elasticity (95 ± 5 GPa) and coefficient of thermal expansion ($10.15 \pm 0.4 \times 10^{-6} \text{K}^{-1}$) are the same for both e.maxPRESS and e.maxCAD.^{56,57}

Lithium disilicate is desirable for all-ceramic restorations because it provides esthetics, favorable light translucency,⁵⁸ biocompatibility,⁴⁹ high strength, and high fracture toughness.^{59,60,61,62} Recent literature supports the use of all-ceramic restorations, citing a 90% success rate for single unit restorations, irrespective of the observation time or materials used. A study by Gehrt *et al* reported a cumulative survival rate of 97.4% after 5 years and 94.8% after 8 years of clinical service for IPS e.max all-ceramic restorations.⁶³ Furthermore, their study concluded that crown location (anterior versus posterior) nor type of cement (glass ionomer versus adhesive), did not significantly compromise survival.⁶³ Guess *et al* also reported low failure rates (100% survival) for pressed all-ceramic restorations, citing improved flexural strength and homogeneity.⁶¹ The benefit of a monolithic block is homogeneity, density, and decreased porosity or voids which maximize material properties.⁴⁶

Lithium disilicate as a CAD ingot has obvious benefits. CAD/CAM fabrication is economical due to reduced fabrication of steps, less material waste, and decreased labor hours.⁴⁸ However, physical properties vary between pressed versus CAD materials, as noted previously. Important to note is that during the crystallization process, the restoration undergoes a small

dimensional change of 0.2% which is compensated for in the design software.⁶⁴ Furthermore, heat-pressed lithium disilicate has a higher Weibull modulus than the CAD form.^{56,57} This implies CAD manufacturing may produce specimens with lower reliability; a consistent processing technique does not necessarily result in better mechanical properties.⁶⁵ Other studies have highlighted differences arising from the machining process. Milling ceramic with diamond-coated instruments induces surface damage in the form of microcracks.⁶⁶ Pores within the material formed during processing, combined with machining induced flaws, lead to early crack formation and reduced fracture strength.^{67,66} Bindl and Mormann demonstrated that milled restorations had poor internal fit, compared to press materials; 75 μm internal adaptation for e.maxPRESS, versus 116 μm for e.maxCAD.¹⁰

Although Gehrt *et al*⁶³ concluded that location of the restoration did not influence success of all-ceramic restorations, most other studies contradict this result. A number of other investigators have reported full coverage molar restorations had greater risk for failure when compared to anterior and premolar teeth.^{61,68,69,70,71,72} Goodacre *et al.* reported clinical fracture rates for all-ceramic restorations as 21% for molars, 7% for premolars, and 3% for anterior teeth.⁷⁰ Posterior teeth are subject to greater masticatory forces which accounts for higher failure rates of full coverage molar restorations. This is often compounded with inadequate reduction of the occlusal surface, leading to thin material. The minimum recommended proximal thickness of lithium disilicate is 0.8 mm and 1.5-2.0 mm for the occlusal table.⁷³ Baltzer (2008) analyzed 50 anterior and 50 posterior preparations and found on average 1.1 mm occlusal reduction of posterior teeth and 0.9 mm incisal reduction for anterior teeth; far less than 1.5-2.0 mm reduction recommended by the manufacturer.⁷⁴ Malament in 1999, agreed location was a factor in survival, but did not believe that material thickness was related to survival. He argued a thicker material did have greater strength, but increase in thickness offers little improvement within the limits of

stresses produced within the oral cavity.⁷⁴ In general however, it is better to have a thicker glass ceramic layer. The load required to cause bulk fracture from radial cracks increases as the square of the thickness increases.⁶²

The most common cause of ceramic failure is fracture initiating from within the material.⁶² This is usually not a factor when there is sufficient material thickness, but could be implicated in cases of insufficient preparation reduction.⁶² Lithium disilicate is more susceptible to slow crack propagation than either leucite-based porcelains or ceramics.⁶⁰ Clinical longevity of ceramic restorations is often limited by a slow crack propagation process.^{53,60} According to Rekow *et al*, cracks predominate in two areas. Radial cracks develop at the cementation surface. Near-field cracks (cone cracks) develop in close proximity to the applied load, at or near the occlusal surface.⁷⁵ Their study concluded that ceramic thickness, rather than inherent material properties, is the most important factor relating to load required for initial radial fracture.⁷⁵ As thickness increases, the load required to initiate fracture increases dramatically (square of the thickness).^{10,75}

D. Zirconia

Because of interest in improving esthetics and providing biocompatible restorations, zirconia was adapted for dental restorative purposes. It was developed after techniques were discovered to transformation toughen the material in the mid-1970's.⁷⁶ Zirconium began use as a dental material in the late 1990's. It is found in three forms depending on temperature: from room temperature to 1170° is a monoclinic form; from 1170° to 2370°C is a tetragonal form; and above 2370°C is a cubic form.⁷⁷ As zirconia is cooled from the tetragonal to the monoclinic form, it expands approximately 4.5% in volume which can initiate fracturing of the material.⁷⁶ It was found that adding oxides to zirconia will stabilize and allow retention of the tetragonal structure at room temperature. Stabilized zirconium is found to have favorable physical properties and appears

esthetically well-suited, which makes it useful for restorative dentistry. In dentistry, yttria-stabilized zirconia, magnesium cation doped partially-stabilized zirconia, and zirconia-toughened alumina have been used.⁷⁷ This zirconia oxide needs to go through a sintering process and as it slowly cooled, the restorations contract approximately 25%.⁷⁶

E. Polymethyl Methacrylate

Acrylic polymers were introduced to dentistry in 1937.⁷⁸ Polymers used include: vinyl acrylics, polystyrene, epoxies, polycarbonates, polyvinylacetate-polyethylene, polyisoprene, polysulfides, silicones, polyethers, and polyacrylic acids.⁷⁸ Polymethyl methacrylate (PMMA) is used for provisional restorations because of low cost, good strength, good dimensional stability, and acceptable marginal adaptation.⁷⁹ However, PMMA can have porosity, poor color stability, and a poor surface texture.⁷⁹ PMMA typically comes in a powder and liquid form, which necessitates manual measuring, mixing, and polymerization. With CAD/CAM technology, pre-polymerized PMMA can be milled. This material is more durable, possess superior physical properties, and better fit than conventionally mixed PMMA.⁸⁰

SUMMARY

Dentists can select from a number of different tooth-colored ceramic materials that differ in physical properties, chemical structures, and manufacturing techniques. They require unique fabrication techniques and post-processing procedures for each material. Milled lithium disilicate is one commonly used material and requires a post-milling crystallization process that introduces a small dimensional change of 0.2 % and zirconia has approximately 25% shrinkage after the sintering process. One factor affecting the longevity of a restoration is the restorative material thickness. A thicker restorative material typically has greater fracture resistance. One of the major

limitations in accuracy of milling is the size of the diamond bur. The machine can compensate by over-milling the area to fit the dimension of the bur. Because of the dimensional change of zirconia material during sintering, it is likely that zirconia could have a better fit, as the material could strategically reduce the internal overmilled spaces.

This study investigated and compared the internal adaptation of different restorative materials prepared from the same three-axis mill. The objective was to compare differences in internal adaptation between four different materials milled by a 3-axis mill for an anterior restoration.

CHAPTER III: MATERIALS AND METHODS

This methodology is based on a previous NPDS study, IRBNet #399997 Comparison of the Internal Adaptation of 3 vs 5 Axis CAD/CAM Milled Lithium-Disilicate Anterior Restorations.¹⁰

A de-identified #8 anterior tooth was mounted in Type IV stone base (Silky Rock, Whip Mix, Louisville, KY) and putty index of the crown shape fabricated (Figure 1). The putty index was used to verify proper reduction.

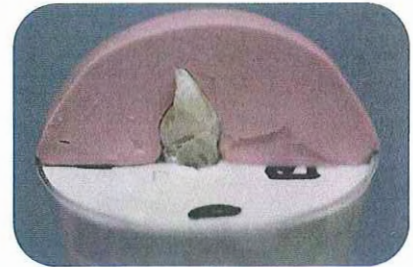

Figure 1. Cross section of the putty matrix.

The tooth was prepared for an all-ceramic restoration (ACR) following Ivoclar Vivadent, Inc. (Amherst, NY) guidelines (Figure 2). The guidelines specify a uniform butt joint margin of 1.0 mm, a facial reduction of 1-1.5 mm, a lingual reduction of 1.5 mm, and an incisal reduction of 1.5-2 mm (see Figure 3 and 4). These specifications insure a proper bulk of material for strength and esthetics of the final restoration. A

modified shoulder diamond bur 847KR16 for incisal and circumferential reduction, and football diamond bur 379023 for lingual reduction were used (Brasseler USA, Savannah, GA).

Full-Coverage Restorations

ANTERIOR CROWN PREPARATION

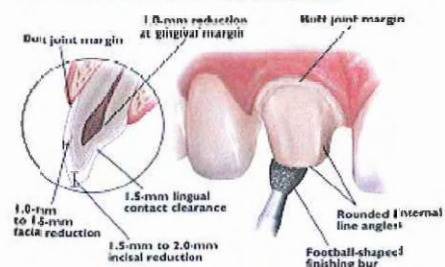

Figure 2. Ivoclar Vivadent, Inc.; all-ceramic chairside preparation guide for IPS emax anterior crown preparation.



Figure 3. Reduction of the preparation from the original crown.

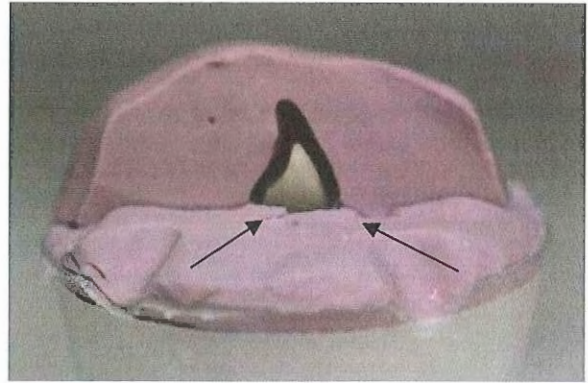

Figure 4. Putty base with arrows indicating notches needed for orientation. **Figure 1.** Cross-section of the putty index.

A putty base was added around the preparation to mimic the gingiva. Notches were placed in the putty for orientation purposes when imaging the preparation (Figure 4).

A CEREC Bluecam was used to image the prepared crown (Sirona Dental Systems, GmbH, Bensheim, Germany). The Bluecam uses a blue diode LED that emits a blue light of a short wavelength. The light is projected in a striped pattern on the preparation. A sensor detects reflected light and measures distance between the projected and reflected rays. The known value of the fixed angle between the projector and sensor is used to calculate distance to the preparation via the Pythagorean theorem. The term used for this means of data acquisition is “active triangulation” (Figure 5).⁸¹

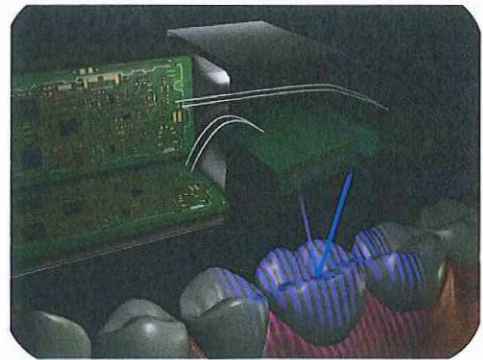

Figure 5. From Van der Meer WJ et al⁸¹; diagram depicting the light striations and reflection back to the sensor for calculation of the distance to the object.

The Bluecam STL file (Figure 6) was exported to another design program, 3matic (Materialise; Leuven, Belgium). This allowed slight modifications to be made in preparation geometry in order to obtain an ideal preparation in accordance to Ivoclar’s specification for anterior teeth.

Using 3matic, frameworks were designed to contain a tooth, die, crown, and stone to facilitate later sample sectioning. The facial surface was identified along with a notch on the top to facilitate repeatable positioning of all frameworks during sectioning. On the distal (or left side) a triangular key was incorporated into the framework design. The rationale for the key was two-fold; it would lock into the holder to maintain repeatable positioning for sectioning, and repeatably align and hold specimens in a Hirox microscope for data acquisition (Figure 7).

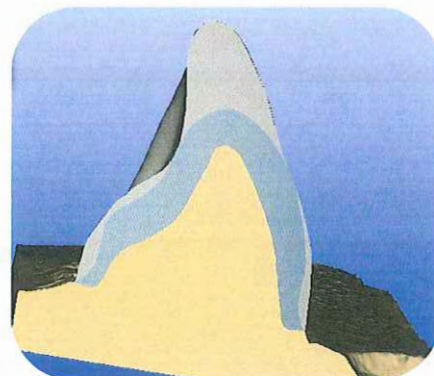

Figure 6. Digital scan of the die with preparation design. Blue band indicates desired thickness of ceramic material.

Sample Fabrication

40 dies and framework units were printed via jetting additive manufacture (Stratasys Objet 30; Eden Prairie, MN) using a light-cured resin material (Viro Plus 835, Stratasys Objet 30; Eden Prairie, MN). All dies were printed with the same batch of material simultaneously to ensure all were duplicates of one another.

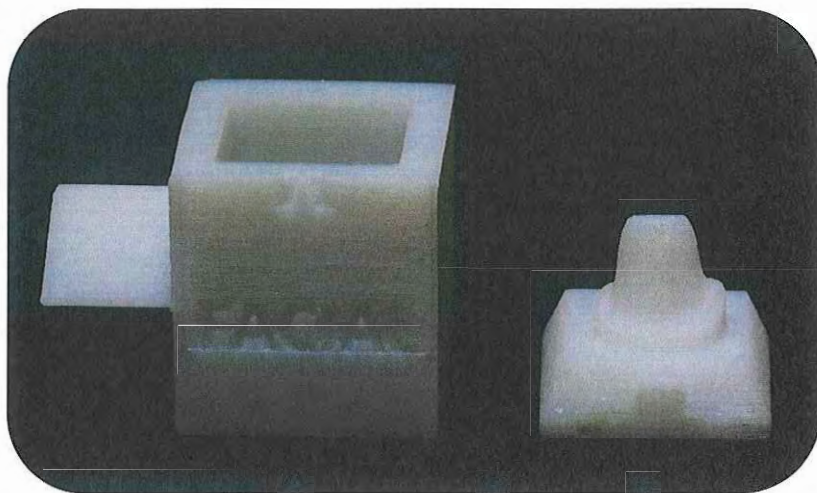

Figure 7. On the left is the framework that clearly specifies the position of the die within the holder. Sticking out on the left side is the triangular “key.” The right image is the facial preparation die; the notch seen on the front the base locks it into the framework so that the die is positioned the same way every time.

A single die was sprayed with CEREC Optispray (Sirona Dental Systems, GmbH; Bensheim, Germany) and imaged with the Omnicam (Sirona Dental Systems GmbH; Bensheim,

Germany) image capturing system.

An optimal thickness crown was designed using the CEREC 4.0 (Sirona Dental Systems GmbH; Bensheim, Germany) software program. The design was created following Ivoclar Vivadent, Inc. recommendations for tooth preparation (Figure 8).⁸²

Ten IPS e.maxCAD (Ivoclar Vivadent, Inc.; Amherst, NY) all-ceramic restorations, 10 InCoris ZI (Sirona) all-ceramic zirconia restorations, were milled with the Sirona MC XL (Sirona Dental Systems GmbH; Bensheim, Germany).

IPS e.maxCAD ingots are available for milling in the “blue state”: an uncrystallized lithium metasilicate which is softer and easier to mill. Once crystallized into lithium disilicate, the ceramic is difficult to mill and produces excessive heat and bur wear. Additionally, the ceramic becomes subject to abrasion and cracking. IPS e.maxCAD blocks consist of 0.2-1.0 μm lithium metasilicate crystals, with approximately 40% crystals⁸³ in the uncrystallized state. Milling uncrystallized material puts less strain on the milling unit.

Ten Sirona CEREC Block (Sirona) all-ceramic restorations (feldspathic), and 10 Telio CAD (Ivoclar Vivadent) polymethyl methacrylate restorations were milled (Figure 9) using the Sirona MC XL (Sirona Dental Systems GmbH; Bensheim, Germany).

Each restoration was placed in a numbered container. The investigator recorded which

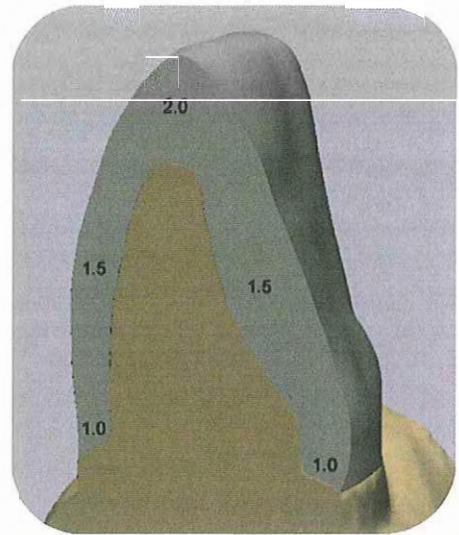

Figure 8. Depiction from CEREC showing the ideal thickness for an IPS.e.max all ceramic restoration.

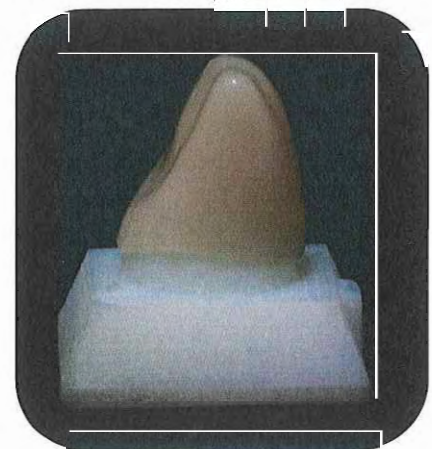

Figure 9. Example of a restoration milled out using Sirona MC XL.

material corresponded to the numbered specimen.

Lithium disilicate restorations were crystallized in a Programat P700/G2 (Ivoclar Vivadent, Inc.; Amherst, NY) porcelain furnace. The crystallization program for IPS e.maxCAD was:

- a. Stand-by temperature: 550°C
- b. Drying Stand time: 6 minutes
- c. Heating rate t_1 : 90°C/minute
- d. Firing temperature T_1 : 820°C
- e. Vacuum 1: 1_1 820°C
- f. Holding time H_1 : 10 seconds
- g. Heating rate t_2 : 30°C/minute
- h. Firing temperature T_2 : 840°C
- i. Vacuum 2: 2_1 840°C
- j. Holding time H_2 : 7 minutes
- k. Long-term cooling L : 700°C
- l. Cooling rate t : 0°C/minute

Fabrication involves a two-stage firing process under vacuum to complete crystallization of lithium disilicate. It converts the blue shade of the block into the designated tooth shade and results in a glass-ceramic with a fine grain size (approximately 1.5 μm) and 70% crystal volume in a glassy matrix.⁸³

InCoris ZI zirconia restorations undergoes a sintering process in a Ceramill Therm (Amann Girschbach AG; Koblach, Austria) sintering oven. The sintering program for InCoris ZI is:

- a. Stand-by temperature: 20°C
- b. Firing temperature T₁: 900°C
- c. Heating rate t₁: 3°C/minute
- d. Holding time H₁: 30 minutes
- e. Firing temperature T₂: 1450°C
- f. Heating rate t₂: 3°C/minute
- g. Holding time H₂: 120 minutes
- h. Firing temperature T₃: 900°C
- i. Heating rate t₃: -5°C/minute
- j. Holding time H₃: 1 minute
- k. Cooling L: 200°C
- l. Cooling rate t: 0°C/min

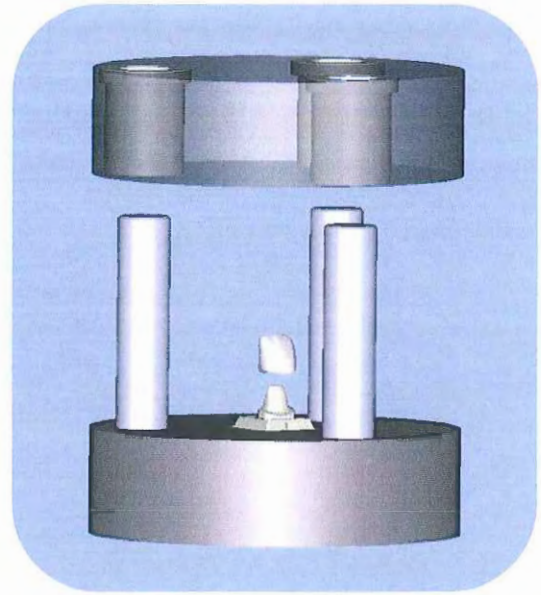

Figure 10. Seating jig, a 5 lb. weight is placed on the top for seating pressure

A seating jig was fabricated to ensure each restoration was cemented with the same seating direction and force. Each sample was cemented with 5 lbs. of force (Figure 10). Glass ionomer (Ketac Fil Plus, 3M ESPE; St. Paul, MN) was used to cement all restorations. Excess cement was removed with a microbrush prior to setting.

Excess cement was removed after initial set and the framework boxes were placed onto the cemented preparations and filled with low expansion stone Type IV stone (Silky Rock, Whip Mix; Louisville, KY). This provided a standard shape for cutting and imaging purposes. Excess stone was wiped off evenly with the top of the

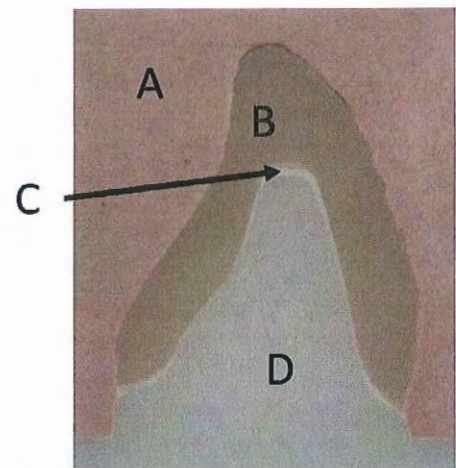

Figure 11. Image shows the buccal-lingual cross-section where A) is the low expansion stone, B) is the all-ceramic crown, C) with the arrow pointing to the cement thickness, and D) is the resin die.

framework prior to setting.

Each die was sectioned with a diamond blade using an Isomet 1000 (Buehler; Lake Bluff, IL) sectioning saw. The triangular key on the framework box indexed the saw to provide repeatable positioning and cutting of each die.

Once sectioned, each die was be polished sequentially up to 600 grit on a Handimet 2 Roll Grinder (Bue hler; Lake Bluff, IL) (Figure 11).

A KH 7700 Hirox 3D Digital Scanner (Seika Machinery Inc, Seika Corp, Tokyo, Japan) was used to measure internal adaptation (cement thickness) for each specimen. A standard positioning mount was fabricated to fit the key of the framework; each specimen was positioned under the microscope in the same position.

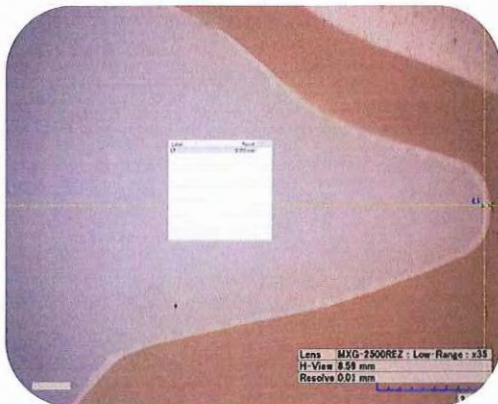

Figure 12. The “T” cross-hair screen. L1 indicates the middle of the incisal edge and the point that will be used for initial alignment.

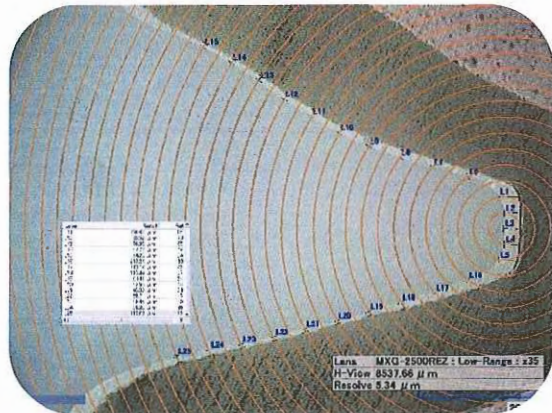

Figure 13. Radial screen; distance between each ring is equivalent to 0.25 mm.

The cross-hair “T” screen was used to mark a first point at the middle of the incisal edge for initial alignment (Figure 12). Once the first point was established, the radial template screen was used to mark the remaining measurement points. The first point marked was the center of a circle. The radial separation was set to 0.25 mm (Figure 13).

Data Acquisition/Recording

Measurements were recorded from a point selected on the outer edge of the preparation,

perpendicular to a point on the inner aspect of the restoration.

A pilot study showed the measurement recordings on the facial and lingual surfaces were fairly constant for each 0.25 mm of radial increment. Facial and lingual measurements were made at 0.5 mm radial increments.

Separation of facial, incisal, lingual areas are shown in Figure 14. The incisal area showed measurements that varied significantly between each 0.25 mm radial segment. Measurements were started at the midline and continued every 0.25 mm, up to the 5th radial segment. A total of 5 data points for the incisal area were collected.

Lingual measurement started on the 7th radial segment. Measurements were be collected every 0.5 mm (every other radial segment) for a total of 10 data points. Facial measurement were also started on the 7th radial segment. Measurements were collected every 0.5 mm (every other radial segment) for a total of 10 data points.

The Hirox microscope automatically recorded all measurements in a CSV file (Figure 15).

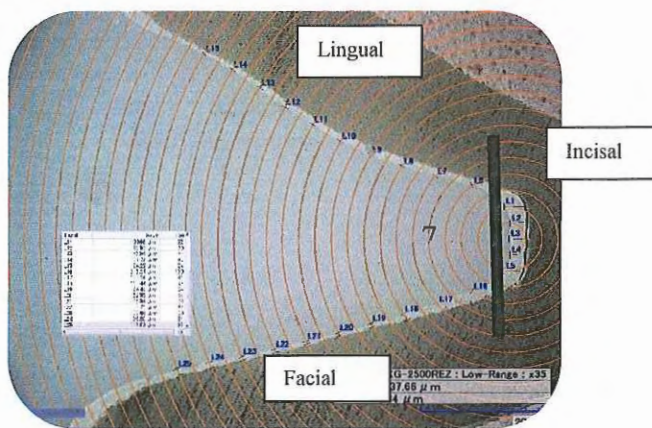

Figure 14. Radial screen. Dark line indicates separation between facial, incisal, and lingual areas. The number 7 is pointing out the seventh radial curve which will be the starting point for both the lingual and buccal measurements on their respective side.

Label	Result
L17	0.094 mm
L18	0.138 mm
L19	0.096 mm
L20	0.096 mm
L21	0.111 mm
L22	0.080 mm
L23	0.118 mm
L24	0.114 mm
L25	0.115 mm
L26	0.082 mm
L27	0.100 mm
L28	0.094 mm
L29	0.071 mm
L30	0.083 mm
L31	0.101 mm
L32	0.137 mm

Figure 15. Enlargement of the measurements as seen on the Hirox screen.

Chapter IV: Results

Assessing the mean internal adaptation for each of the materials with the 25 data points, the feldspathic porcelain had the largest mean internal adaptation at 161 μm . The feldspathic porcelain also had the largest standard deviation of 121.6 μm resulting with a range from 39 μm to 283 μm . The other three materials had a mean that were grouped relatively close together, near 100 μm which is the value selected for the cement spacer. The lithium disilicate had a mean internal adaptation of $128.6 \pm 100.2 \mu\text{m}$. The zirconia restorations were found to have a mean internal adaptation of $121.8 \pm 68.5 \mu\text{m}$. The polymethyl methacrylate restorations had a mean internal adaptation of $102.8 \pm 65.5 \mu\text{m}$ (Table 1, Graph 1). The one-way ANOVA evaluation was completed and showed a p-value of 0.074.

Material	Mean (μm)	Standard Deviation (μm)
PMMA	102.8	± 65.5
Feldspathic	161.1	± 121.6
Zirconia	121.8	± 68.5
Lithium disilicate	128.6	± 100.2

Table 1: The mean and standard deviations of internal adaptation evaluated by material

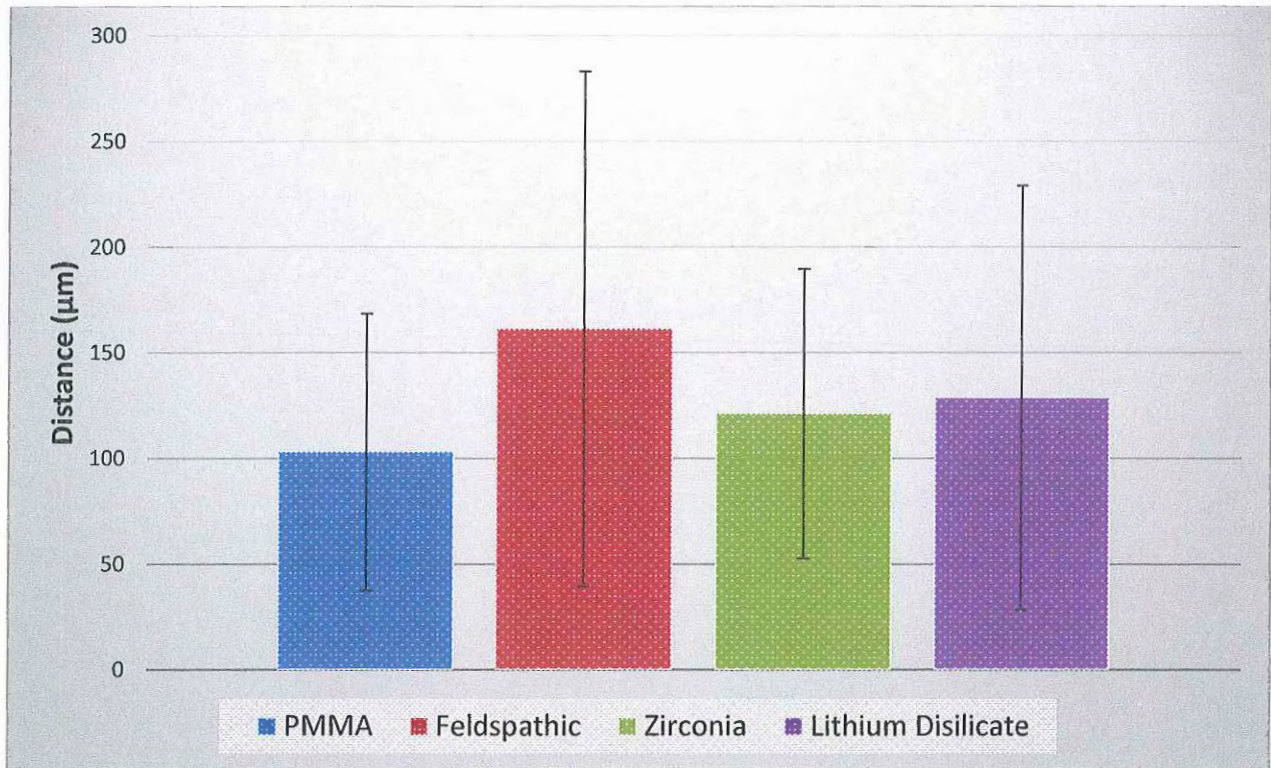

Graph 1: Mean Internal Adaptation by Material

The data was further evaluated by surface. The incisal surfaces had a mean internal adaption of $274.5 \pm 85.9 \mu\text{m}$. The lingual surfaces had a mean internal adaptation of $108.2 \pm 46.7 \mu\text{m}$. The facial surface had the least mean internal adaptation of $76.1 \pm 49.5 \mu\text{m}$ (Table 2, Graph 2). A one-way ANOVA found a highly significant difference in the internal adaptation between the surfaces with a p-value of less than 0.001. A Tukey post hoc test individually compared the

relationship of the surfaces. The test found highly significant differences between incisal surface and the facial surface with a p-value less than 0.001. When the incisal surface was compared to the lingual surface, the p-value was also less than 0.001. When comparing the facial surface to the lingual surface, the p-value was also significant with a value of 0.002.

Surface	Mean (μm)	Standard Deviation (μm)
Incisal	274.5	± 85.9
Facial	76.1	± 49.5
Lingual	108.2	± 46.7

Table 2: The mean and standard deviations of internal adaptation evaluated by surface

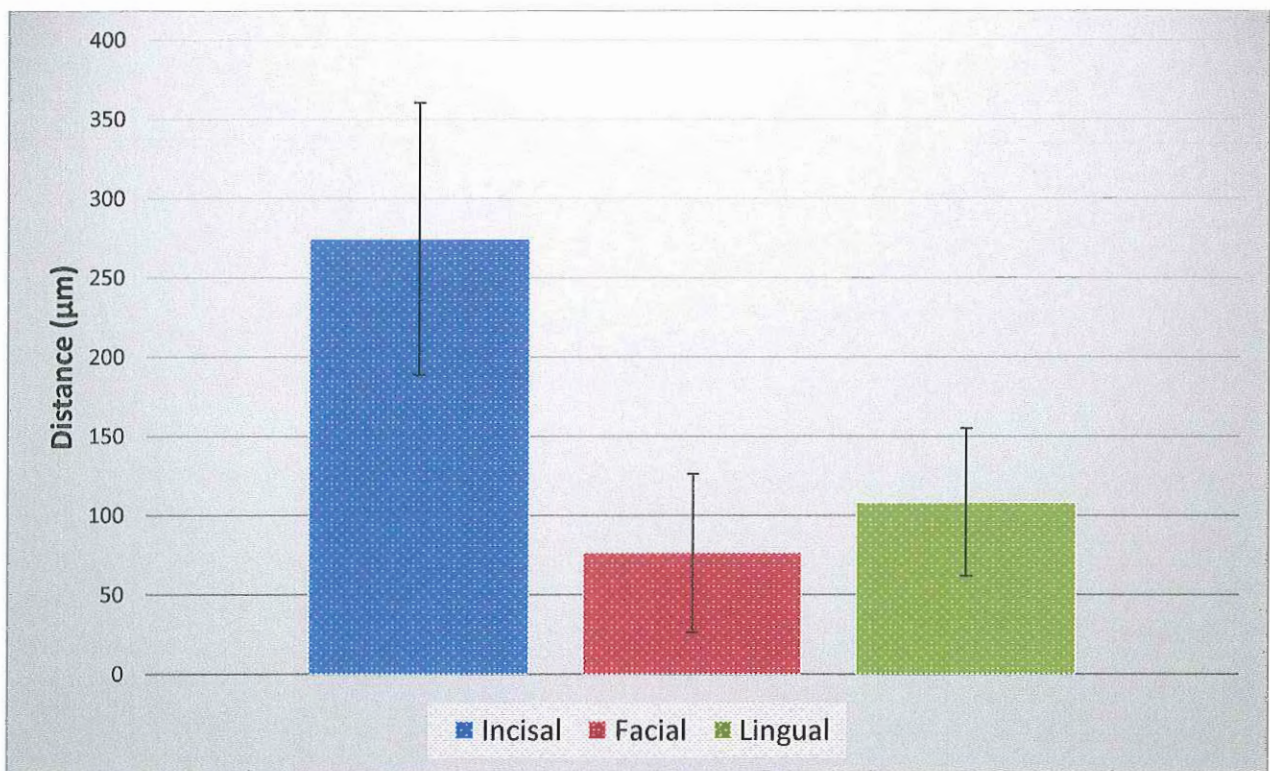

Graph 2: Mean Internal Adaptation by Surface

Chapter V: Discussion

For observations, the data was further broken down based on the sample surface and by the material (Table 3, Graph 3). The mean internal adaptation on the incisal surfaces were greater than the mean calculated on the facial or the lingual for all four of the materials. The facial and lingual measurements for all materials were relatively close to the cement spacer setting of 100 μm . The facial mean for the materials were (μm): 67.4, 91.0, 67.6, and 78.6, with the feldspathic porcelain having the greatest amount of internal adaptation. The feldspathic porcelain also had the highest means in each measured surface. Consistency was observed in that the means on the incisal surface for each of the materials was greater than the means on the lingual surface which was greater than the means on the facial surface. The ideal internal adaptation should be less than 70 μm for increased fracture resistance and better bonding.¹ This held true for the facial and lingual surface, but at the incisal surface, all of the means of the materials were larger than the cement spacer setting of 100 μm and the ideal internal adaptation. The feldspathic porcelain had measurements approaching 450 μm on the incisal surface which has been shown that bonding benefits are lost due to polymerization shrinkage of the resin cement and also reduces fracture resistance.¹¹

	Incisal		Facial		Lingual	
	Mean (µm)	Standard Deviation (µm)	Mean (µm)	Standard Deviation (µm)	Mean (µm)	Standard Deviation (µm)
PMMA	213.1	±45.0	67.4	±28.2	83.2	±34.8
Feldspathic	355.5	±97.5	91.0	±58.2	134.0	±66.2
Zirconia	233.1	±43.0	67.6	±31.4	120.4	±25.6
Lithium disilicate	274.5	±85.9	76.1	±49.5	108.2	±46.7

Table 3: The mean and standard deviations of internal adaptation evaluated by surface and material

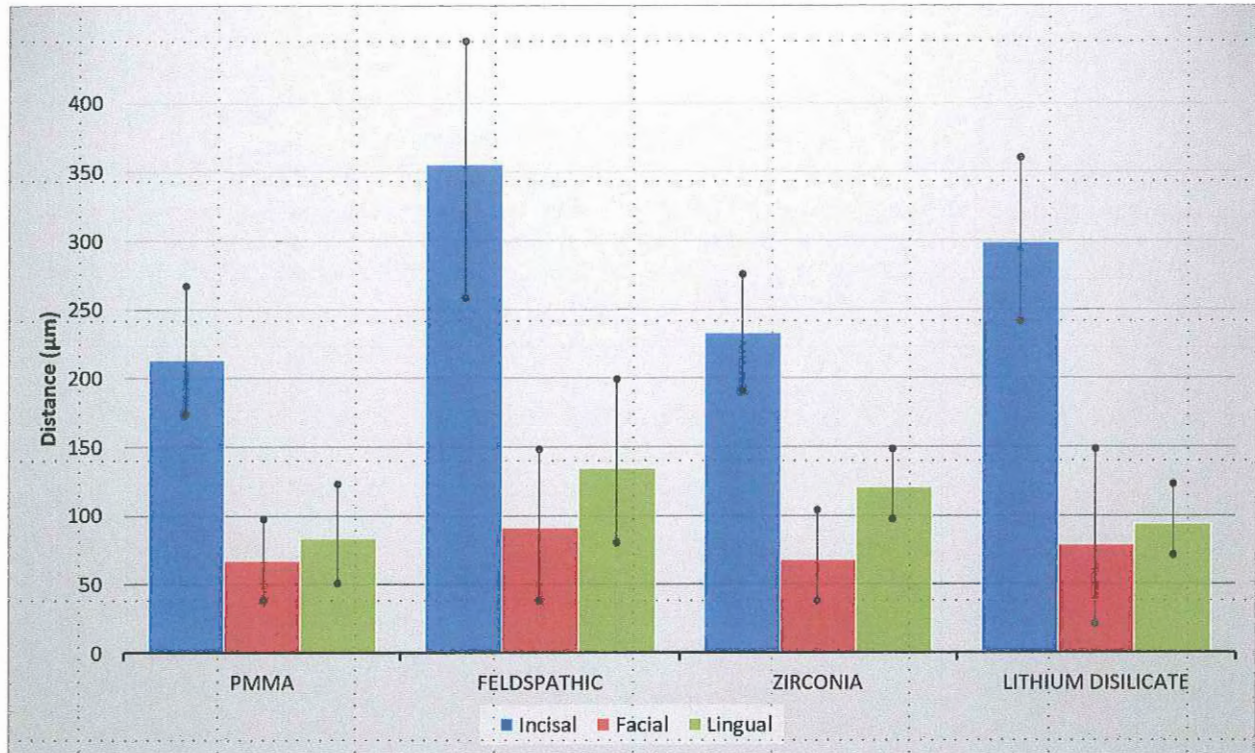

Graph 3: Mean Internal Adaptation by Material and Surface

There are possible reasons as for why the internal adaptation at the incisal surface is significantly different than the internal adaptation of the lingual or the facial surface. The milling strategy intentionally overmills in areas where the dimensions approach the bur diameter to facilitate complete seating of the restoration. The narrowest part of the die is the incisal edge and the most mesial and distal line angles are angular (figure 16). For the bur to mill the intaglio surface, it will overmill the more angular and narrower areas that are difficult to reach. This is part

of the suspected reason why the incisal edge has more internal adaptation than the facial or the lingual surface. It is also possible that the scanner has difficulty in capturing the data from a sharp angle with a high a degree of accuracy, carrying the error to the milling. This would compound the error and potentially create a larger internal adaptation on the incisal surface. From graph 3, it shows that each material has different calculated means, especially at the incisal surface.

Feldspathic and the lithium disilicate have greater internal adaptation than the zirconia and the polymethyl methacrylate. Using the Sirona MC XL, it was observed that a smaller diameter bur of 0.9 mm milled the intaglio surface of the zirconia and the polymethyl methacrylate material rather than the standard milling bur of 1.2 mm. This could explain the large difference between the feldspathic/lithium disilicate group to the zirconia/polymethyl methacrylate group. These are the burs selected by Sirona for the material by default. This demonstrates that there is a different milling strategy for each material especially where the mill must compensate for materials that undergo dimensional change post milling such as lithium disilicate and zirconia.

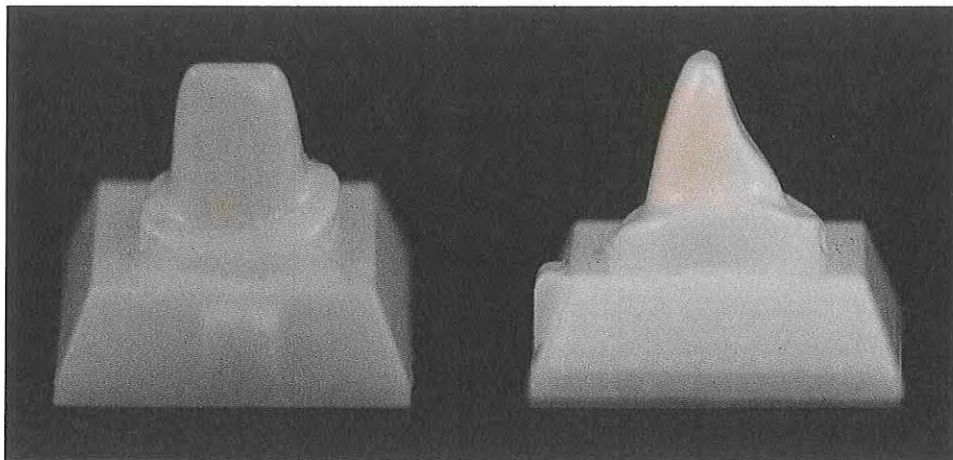

Figure 16: Facial and profile view of printed die

Chapter VI: Conclusion

The findings in the study showed a significant difference in the surface that were milled when compared to the other. It was also found that there is no significant difference in the internal adaptation of different materials milled from a 3-axis mill.

Evidence supports that differences in the manufacturing process of various materials did not affect internal adaptation. This demonstrated that the dimensional change of zirconia did not produce a significant difference of internal adaptation when compared to other restorative materials. The data does not disprove the null hypothesis. The p-value was approaching significance, but there was not sufficient significant difference between the materials.

References

1. Colpani JT, Borba MM, Della Bona A, Della Bona Á. Evaluation of marginal and internal fit of ceramic crown copings. *Dent Mater.* 2013;29(2):174–80.
2. Denry IL. Recent advances in ceramics for dentistry. *Crit Rev Oral Biol Med.* 1996;7(2):134–43.
3. Wassermann A, Kaiser M, Strub JR. Clinical long-term results of VITA In-Ceram Classic crowns and fixed partial dentures: A systematic literature review. *Int J Prosthodont.* 2006;19(4):355–63.
4. Boening KW, Wolf BH, Schmidt AE, Kästner K, Walter MH. Clinical fit of procera AllCeram crowns. *J Prosthet Dent.* 2000;84:419–424.
5. Martins LM, Lorenzoni FC, Melo AO De, et al. Internal fit of two all-ceramic systems and metal-ceramic crowns. *J Appl Oral Sci.* 2012;20(2):235–240.
6. Donovan TE. Factors essential for successful all-ceramic restorations. *J Am Dent Assoc.* 2008;139 Suppl(suppl 4):14S–18S.
7. Ditolla MC. Why Dentists Love BruxZir Solid Zirconia. *Dentaltown.* 2007:20–21.
8. Schaefer O, Watts DC, Sigusch BW, Kuepper H, Guentsch A. Marginal and internal fit of pressed lithium disilicate partial crowns in vitro: a three-dimensional analysis of accuracy and reproducibility. *Dent Mater.* 2012;28(3):320–6.
9. Kokubo Y, Ohkubo C, Tsumita M, Miyashita a, Vult von Steyern P, Fukushima S. Clinical marginal and internal gaps of Procera AllCeram crowns. *J Oral Rehabil.* 2005;32(7):526–30.
10. Hogan J. *Comparison of the Internal Adaptation of 3-Axis Versus 5-Axis CAD/CAM Milled Lithium-Disilicate Anterior Restorations.*; 2014.
11. May LG, Kelly JR, Bottino M a., Hill T. Effects of cement thickness and bonding on the failure loads of CAD/CAM ceramic crowns: Multi-physics FEA modeling and monotonic testing. *Dent Mater.* 2012;28(8):e99–e109.
12. Nakamura T, Nonaka M, Maruyama T. In vitro fitting accuracy of copy-milled alumina cores and all-ceramic crowns. *Int J Prosthodont.* 2000;13(3):189–93.
13. Prakki A, Cilli R, Da Costa AU, De Paiva Goncalves SE, Lia Mondelli RF, Pereira JC. Effect of resin luting film thickness on fracture resistance of a ceramic cemented to dentin. *J Prosthodont.* 2007;16(3):172–178.
14. Kaufman, Edward; Coelho, David; Colin L. Factors influencing the retention of cemented gold castings. *J Prosthet Dent.* 1961;11(3):487–502.
15. Jorgensen K. The relationship between retention and convergence angle in cemented veneer crowns. *Acta Odontol Scand.* 1955;13(1):35–40.
16. Goodacre CJ. Tooth preparations for complete crowns: An art form based on scientific principles. *J Prosthet Dent.* 2001;85(4):363–376.
17. Shillingburg HT, Hobo S WL. *Fundamentals of fixed prosthodontics, fourth edition.*; 2012.
18. Caputo, Angelo A; Standlee JP. *Biomechanics in Clinical Dentistry.*; 1987.
19. Parker, M H; Malone, Kay H; Trier, Ashton C; Striano T s. Evaluation of resistance form for prepared teeth. *J Prosthet Dent.* 1991;66(6):730–733.
20. Parker MH, Calverley MJ, Gardner FM, Gunderson RB. New guidelines for preparation taper. *J Prosthodont.* 1993;2(1):61–6.
21. Parker, M H; Gunderson, R B; Gardner, F M; Calverley MJ. Quantitative determination of taper adequate to provide resistance form: Concept of limiting taper. *J pro.* 1988;59(3):281–288.

22. Trier AC, Parker MH, Cameron SM, Brousseau JS. Evaluation of resistance form of dislodged crowns and retainers. *J Prosthet Dent*. 1998;80(4):405–409.
23. Parker MH. Resistance form in tooth preparation. *Dent Clin North Am*. 2004;48(2):387–396.
24. Chiche, Gerard J; Pinault A. *Esthetics of Anterior Fixed Prosthodontics - Quintessence Pub; 1 edition (January 15, 1994).pdf*; 1994.
25. Jorgensen K. Factors affecting the film thickness of zinc phosphate cements. *Acta Odontol Scand*. 1960;18:479–490.
26. Jorgensen, Knud; Esbensen AL. The relationship between the film thickness of zinc phosphate cement and the retention of veneer crowns.pdf. *Acta Odontol Scand*. 1968;26:169–174.
27. Anadioti E, Aquilino S a, Gratton DG, et al. Internal fit of pressed and computer-aided design/computer-aided manufacturing ceramic crowns made from digital and conventional impressions. *J Prosthet Dent*. 2014.
28. Holmes, J Robert; Bayne, Stephen C; Holland, Gene A; Sulik WD. Considerations in measurement of marginal fit. *J pro*. 1989;62(4):405–408.
29. Souza ROA, Özcan M, Pavanelli CA, et al. Marginal and Internal Discrepancies Related to Margin Design of Ceramic Crowns Fabricated by a CAD/CAM System. *J Prosthodont*. 2012;21(2):94–100.
30. Mou SH, Chai T, Wang JS, Shiau YY. Influence of different convergence angles and tooth preparation heights on the internal adaptation of Cerec crowns. *J Prosthet Dent*. 2002;87(3):248–255.
31. Nakamura T, Dei N, Kojima T, Wakabayashi K. Marginal and internal fit of Cerec 3 CAD/CAM all-ceramic crowns. *Int J Prosthodont*. 2003;16(3):244–248.
32. Mörmann WH, Bindl a, Lüthy H, Rathke a. Effects of preparation and luting system on all-ceramic computer-generated crowns. *Int J Prosthodont*. 1998;11(4):333–9.
33. Bindl a., Mörmann WH. Marginal and internal fit of all-ceramic CAD/CAM crown-copings on chamfer preparations. *J Oral Rehabil*. 2005;32(16):441–447.
34. Keshvad A, Hooshmand T, Asefzadeh F, Khalilinejad F, Alihemmati M, van Noort R. Marginal gap, internal fit, and fracture load of leucite-reinforced ceramic inlays fabricated by CEREC inLab and hot-pressed techniques. *J Prosthodont*. 2011;20(7):535–540.
35. Addi S, Hedayati-Khams A, Poya A, Sjögren G. Interface gap size of manually and CAD/CAM-manufactured ceramic inlays/onlays in vitro. *J Dent*. 2002;30(1):53–58.
36. Kern M, Schaller HG, Strub JR. Marginal fit of restorations before and after cementation in vivo. *Int J Prosthodont*. 1993;6(6):585–91. Available at:
37. Wilson P. Effect of increasing cement space on cementation of artificial crowns. *J Pros Den*. 1994;71(6):560–564.
38. Lin MT, Sy-Muñoz J, Muñoz C a, Goodacre CJ, Naylor WP. The effect of tooth preparation form on the fit of Procera copings. *Int J Prosthodont*. 1998;11(6):580–90.
39. Reich S, Wichmann M, Nkenke E, Proeschel P. Clinical fit of all-ceramic three-unit fixed partial dentures, generated with three different CAD/CAM systems. *Eur J Oral Sci*. 2005;113(2):174–179.
40. Yildiz C, Vanlioğlu BA, Evren B, Uludamar A, Ozkan YK. Marginal-internal adaptation and fracture resistance of CAD/CAM crown restorations. *Dent Mater J*. 2013;32(1):42–47.
41. Hamza T a., Ezzat H a., El-Hossary MMK, El Megid Katamish HA, Shokry TE, Rosenstiel SF. Accuracy of ceramic restorations made with two CAD/CAM systems. *J Prosthet Dent*. 2013;109(2):83–87.

42. Schaefer O, Kuepper H, Thompson G a., Cachovan G, Hefti AF, Guentsch A. Effect of CNC-milling on the marginal and internal fit of dental ceramics: A pilot study. *Dent Mater.* 2013;29(8):851–858.
43. Mörmann WH. The evolution of the CEREC system. *J Am Dent Assoc.* 2006;137 Suppl(September):7S–13S.
44. Vanlioglu BA, Evren B, Yildiz C, Uludamar A, Ozkan YK. Internal and marginal adaptation of pressable and computer-aided design/computer-assisted manufacture onlay restorations. *Int J Prosthodont.* 2012;25(3):262–4.
45. Davidowitz G, Kotick PG. The Use of CAD/CAM in Dentistry. *Dent Clin North Am.* 2011;55(3):559–570.
46. Bindl P. The Cerec 3--A quantum leap for computer-aided restorations: Initial clinical results. *Quintessence Int.* 2000;31(10):699–712.
47. Mormann W. The right step to Cerec 3. *Int J Comput Dent.* 2000;3:3–4.
48. Fasbinder D. Chairside CAD/CAM: An Overview of Restorative Material Options. *Compendium.* 2012;33(January).
49. Anusavice, Kenneth J; Shen, Chiayi; Rawls HR. *Phillips' Science of Dental Materials, 12th Edition.* 12th ed. Saunders; 2013.
50. McLean JW, Odont D. Evolution of dental ceramics in the twentieth century. *J Prosthet Dent.* 2001;85(January):61–66.
51. Plengsombut K, Brewer JD, Monaco E a, Davis EL. Effect of two connector designs on the fracture resistance of all-ceramic core materials for fixed dental prostheses. *J Prosthet Dent.* 2009;101(3):166–73.
52. Inan O, Secilmis A, Eraslan O. Effect of pontic framework design on the fracture resistance of implant-supported all-ceramic fixed partial dentures. *J Appl Oral Sci.* 2009;17(5):533–538.
53. Albakry M, Guazzato M, Swain MV. Biaxial flexural strength, elastic moduli, and x-ray diffraction characterization of three pressable all-ceramic materials. *J Prosthet Dent.* 2003;89(4):374–380.
54. Ivoclar-Vivadent-AG. *IPS Empress CAD* ®.
55. Wolfart S, Eschbach S, Scherrer S, Kern M. Clinical outcome of three-unit lithium-disilicate glass-ceramic fixed dental prostheses: Up to 8 years results. *Dent Mater.* 2009;25(9):e63–71.
56. Ivoclar-Vivadent-AG. *IPS e.max* ® *CAD Scientific Documentation.*; 2011.
57. Ivoclar-Vivadent-AG. *Scientific Documentation IPS e.max*® *Press.*; 2011.
58. Baldissara P, Llukacej A, Ciocca L, Valandro FL, Scotti R. Translucency of zirconia copings made with different CAD/CAM systems. *J Prosthet Dent.* 2010;104(1):6–12.
59. Christensen GJ. Esthetic Dentistry–2008. *Alpha Omegan.* 2008;101(2):69–70.
60. Gonzaga CC, Cesar PF, Miranda WG, Yoshimura HN. Slow crack growth and reliability of dental ceramics. *Dent Mater.* 2011;27(4):394–406.
61. Guess PC, Zavanelli R a, Silva NRF a, Bonfante E a, Coelho PG, Thompson VP. Monolithic CAD/CAM lithium disilicate versus veneered Y-TZP crowns: comparison of failure modes and reliability after fatigue. *Int J Prosthodont.* 2010;23(5):434–442.
62. Esquivel-Upshaw JF, Young H, Jones J, Yang M, Anusavice KJ. Four-year clinical performance of a lithia disilicate-based core ceramic for posterior fixed partial dentures. *Int J Prosthodont.* 2008;21(2):155–160. Available at:
63. Gehrt M, Wolfart S, Rafai N, Reich S, Edelhoff D. Clinical results of lithium-disilicate crowns after up to 9 years of service. *Clin Oral Investig.* 2013;17:275–284.

64. Ivoclar-Vivadent-AG. *Monolithic Solutions CHAIRSIDE Instructions for Use.*; 2015.
65. Lin WS, Ercoli C, Feng C, Morton D. The Effect of Core Material, Veneering Porcelain, and Fabrication Technique on the Biaxial Flexural Strength and Weibull Analysis of Selected Dental Ceramics. *J Prosthodont.* 2012;21(5):353–362.
66. Bindl a., Lüthy H, Mörmann WH. Thin-wall ceramic CAD/CAM crown copings: Strength and fracture pattern. *J Oral Rehabil.* 2006;33(10):520–528.
67. Baltzer A. All-ceramic Single-tooth Restorations: Choosing the Material to Match the Preparation-Preparing the tooth to Match the Material. *Int J Comput Dent.* 2008;11:241–256.
68. Wang X, Fan D, Swain MV, Zhao K. A systematic review of all-ceramic crowns: clinical fracture rates in relation to restored tooth type. *Int J Prosthodont.* 2012;25(5):441–50.
69. Ferrario VF, Sforza C, Serrao G, Dellavia C, Tartaglia GM. Single tooth bite forces in healthy young adults. *J Oral Rehabil.* 2004;31(1):18–22.
70. Goodacre CJ, Bernal G, Rungcharassaeng K, Kan JYK. Clinical complications in fixed prosthodontics. *J Prosthet Dent.* 2003;90(1):31–41.
71. Sailer I, Pjetursson BE, Zwahlen M, Hämmerle CHF. A systematic review of the survival and complication rates of all-ceramic and metal-ceramic reconstructions after an observation period of at least 3 years. Part II: Fixed dental prostheses. *Clin Oral Implants Res.* 2007;18(SUPPL. 3):86–96.
72. Malament K a, Socransky SS. Survival of Dicor glass-ceramic dental restorations over 20 years: Part IV. The effects of combinations of variables. *Int J Prosthodont.* 2009;23(2):134–40.
73. Ivoclar-Vivadent-AG. *IPS e.max Clinical Guide.*; 2013.
74. Malament KA, Socransky SS. Survival of Dicor glass-ceramic dental restorations over 14 years. Part II : Effect of thickness of Dicor material and design of tooth preparation. *J Prosthet Dent.* 1999;81(6):662–667.
75. Rekow, E Dianne; Zhang, Yu; Thompson V. Can Material Properties Predict Survival of All-Ceramic Posterior Crowns? *Compendium.* 2007;28(7):362–369.
76. Denry I, Kelly JR. State of the art of zirconia for dental applications. *Dent Mater.* 2008;24(3):299–307.
77. Bachhav VC, Aras MA. Zirconia-based fixed partial dentures: a clinical review. *Quintessence Int.* 2011;42(2):173–182. Available at:
78. Sakaguchi, Ronald L.; Powers JM. *Craig's Restorative Dental Materials.*; 2012.
79. Bidra AS, Manzotti A. A Direct Technique for Fabricating Esthetic Anterior Fixed Provisional Restorations Using Polycarbonate Veneers. *Compendium.* 2012;33(6).
80. Perry, Ronald D; Magnuson B. Provisional Materials: Key Components of Interim Fixed Restorations. *Compendium.* 2012;33(January).
81. van der Meer WJ, Andriessen FS, Wismeijer D, Ren Y. Application of Intra-Oral Dental Scanners in the Digital Workflow of Implantology. *PLoS One.* 2012;7(8):e43312.
82. Ivoclar-Vivadent-AG. *emax_prep_guide.pdf.*
83. Fasbinder D. Using Digital Technology to Enhance Restorative Dentistry. *Compendium.* 2012;33(9):666–677.

{