

REPORT DOCUMENTATION PAGE

Form Approved
OMB No. 0704-0188

The public reporting burden for this collection of information is estimated to average 1 hour per response, including the time for reviewing instructions, searching existing data sources, gathering and maintaining the data needed, and completing and reviewing the collection of information. Send comments regarding this burden estimate or any other aspect of this collection of information, including suggestions for reducing this burden, to Department of Defense, Washington Headquarters Services, Directorate for Information on Operations and Reports (0704-0188), 1215 Jefferson Davis Highway, Suite 1204, Arlington, VA 22202-4302. Respondents should be aware that notwithstanding any other provision of law, no person shall be subject to any penalty for failing to comply with a collection of information if it does not display a currently valid OMB control number.
PLEASE DO NOT RETURN YOUR FORM TO THE ABOVE ADDRESS.

1. REPORT DATE (DD-MM-YYYY) 20-11-2017			2. REPORT TYPE Final		3. DATES COVERED (From - To)	
4. TITLE AND SUBTITLE Test Operations Procedure (TOP) 01-2-515 Reliability Testing Using The Vehicle Durability Simulator				5a. CONTRACT NUMBER		
				5b. GRANT NUMBER		
				5c. PROGRAM ELEMENT NUMBER		
6. AUTHORS				5d. PROJECT NUMBER		
				5e. TASK NUMBER		
				5f. WORK UNIT NUMBER		
7. PERFORMING ORGANIZATION NAME(S) AND ADDRESS(ES) Automotive Directorate (TEDT-AT-AD) U.S. Army Aberdeen Test Center 400 Collieran Road Aberdeen Proving Ground, MD 21005-5059				8. PERFORMING ORGANIZATION REPORT NUMBER TOP 01-2-515		
9. SPONSORING/MONITORING AGENCY NAME(S) AND ADDRESS(ES) Policy and Standardization Division (CSTE-TM) U.S. Army Test and Evaluation Command 2202 Aberdeen Boulevard Aberdeen Proving Ground, MD 21005-5001				10. SPONSOR/MONITOR'S ACRONYM(S)		
				11. SPONSOR/MONITOR'S REPORT NUMBER(S) Same as item 8		
12. DISTRIBUTION/AVAILABILITY STATEMENT Distribution Statement A. Approved for public release; distribution is unlimited.						
13. SUPPLEMENTARY NOTES Defense Technical Information Center (DTIC), AD No.:						
14. ABSTRACT This Test Operations Procedure (TOP) describes methods for performing reliability testing using the Vehicle Durability Simulator (VDS) at the U.S. Army Aberdeen Test Center (ATC) for wheeled vehicles and trailers. The evaluated subsystems for a reliability test on the VDS include structural members, suspension components, armor mounting, and any other chassis mounted subsystems. The VDS does not test reliability of the vehicle powertrain. Testing using the VDS involves mounting the test item on the VDS to excite the system in a controlled manner. Physical responses at various points on the test item are measured with instrumentation such as accelerometers, displacement transducers, inertial measurement units, and wheel force transducers. Actuator drive files for the test item are developed from field data collected with the same, or similar test item. A common set of instrumentation mounted on the vehicle system is used during both field and simulator testing. Test compression techniques are employed to reduce test and simulation time.						
15. SUBJECT TERMS Wheeled vehicle, Trailer, Auto Spectral Density (ASD), Coherence, Transfer Function, Remote Parameter Control (RPC), Multiple-Degree-of-Freedom (MDOF), Frequency Response Function (FRF)						
16. SECURITY CLASSIFICATION OF:			17. LIMITATION OF ABSTRACT SAR	18. NUMBER OF PAGES 55	19a. NAME OF RESPONSIBLE PERSON	
a. REPORT Unclassified	b. ABSTRACT Unclassified	c. THIS PAGE Unclassified			19b. TELEPHONE NUMBER (include area code)	

(This page is intentionally blank.)

U.S. ARMY TEST AND EVALUATION COMMAND
TEST OPERATIONS PROCEDURE

*Test Operations Procedure 01-2-515
DTIC AD No.

20 November 2017

RELIABILITY TESTING USING THE VEHICLE DURABILITY SIMULATOR

		<u>Page</u>	
Paragraph	1.	SCOPE.....	2
	2.	FACILITIES AND INSTRUMENTATION.....	2
	2.1	Instrumentation.....	2
	2.2	Facilities	2
	3.	REQUIRED TEST CONDITIONS AND LIMITATIONS ..	5
	3.1	Test Planning.....	5
	3.2	Test Preparation.....	6
	3.3	Test Limitations.....	7
	4.	TEST PROCEDURES	8
	4.1	Field Data Acquisition	8
	4.2	Data Review	9
	4.3	Drive File Development	11
	5.	LIFE CYCLE TESTING.....	23
	5.1	General	23
	5.2	Test Control Limits	25
	6.	PRESENTATION OF DATA	25
	7.	CONCLUDING REMARKS	27
APPENDIX	A.	EXAMPLE TEST PLAN	A-1
	B.	RAINFLOW COUNTING REVIEW	B-1
	C.	VEHICLE DURABILITY SIMULATOR SPINDLE MATRIX CHANNEL CONFIGURATION	C-1
	D.	REMOTE PARAMETER AND CONTROL MODE DISCUSSION	D-1
	E.	GLOSSARY.....	E-1
	F.	ABBREVIATIONS	F-1
	G.	REFERENCES	G-1
	H.	APPROVAL AUTHORITY.....	H-1

1. SCOPE.

This Test Operations Procedure (TOP) describes methods for performing reliability testing using the Vehicle Durability Simulator (VDS) at the U.S. Army Aberdeen Test Center (ATC) for wheeled vehicles and trailers. The evaluated subsystems for a reliability test on the VDS include structural members, suspension components, armor mounting, and any other chassis mounted subsystems. The VDS does not test reliability of the vehicle powertrain. Testing using the VDS involves mounting the test item on the VDS to excite the system in a controlled manner. Physical responses at various points on the test item are measured with instrumentation such as accelerometers, displacement transducers, inertial measurement units, and wheel force transducers. Actuator drive files for the test item are developed from field data collected with the same, or similar test item. A common set of instrumentation mounted on the vehicle system is used during both field and simulator testing. Test compression techniques are employed to reduce test and simulation time. Through application of these processes and techniques the reliability characteristics of the test item are evaluated over the specified life cycle profile.

2. FACILITIES AND INSTRUMENTATION.

2.1 Instrumentation.

a. Reliability testing with the VDS is performed using data from a variety of sensor types. The sensors are used for measuring accelerations, displacements, angular rate, forces and strains. Common transducers used for making these measurements are accelerometers, string potentiometers, Linear Variable Differential Transformers, inertial measurement units, wheel force transducers and strain gages. Typically, multiple sensor types are necessary to capture the required data for testing on the VDS. A recommended list of instrumentation and installation locations is detailed in the sample test plan provided in Appendix A.

b. It is strongly recommended that during both the field acquisition and laboratory testing the same transducer model and data acquisition signal conditioning is employed for a given sensor location to preserve the signals phase and magnitude response characteristics. Refer to the guidelines in Military Standard (MIL-STD)-810G CN1^{1*} and Institute of Environmental Sciences and Technology (IEST) Recommended Practice IEST-RP-DTE012.2² for recommended accuracy of the transducers and associated signal conditioning.

2.2 Facilities.

a. The main system of the VDS is a MTS 329^{**} Light Truck Multiaxial Spindle-Coupled Road Simulator, which consists of four actuated posts connected to the wheel spindles of a vehicle or trailer. The actuated posts are each capable of movement in six degrees-of-freedom (DOF), and provide the excitation inputs to the test item. The actuator posts can be repositioned to test vehicles with different wheelbases and track widths.

* Superscript numbers correspond to Appendix E, References.

** The use of brand names does not constitute endorsement by the Army or any other agency of the Federal Government, nor does it imply that it is best suited for its intended application.

b. Each corner (post) of the VDS consists of 6 hydraulic actuators connected to a spindle housing. With four posts overall, the VDS has 24 hydraulic actuators (six at each corner) exciting the vehicle in six degrees of freedom. A representative photograph of a High Mobility Multipurpose Wheeled Vehicle (HMMWV) under test is presented in Figure 1. Sensors distributed throughout the test item provide feedback for test control. The sensor types, locations, and orientations are selected based on test item configuration and test requirements.



Figure 1. Overall view of VDS system with vehicle in place.

(1) The individual actuators extend or retract in response to carefully coordinated drive commands developed from data acquired on test vehicles over representative terrain types. Voltage signals are sent to hydraulic servo-valves that control hydraulic oil flow into and out of the actuators, causing them to move. Associated with each actuator are two sensors which measure the actuator displacements (or angles) and loads (forces and moments). A control channel is defined as either “displacement controlled” or “force controlled”, meaning the control channel is attempting to achieve either a displacement command or a force command. A graphical representation of the control loop is presented in Figure 2. The default control configuration for a vehicle test on the VDS is provided in Appendix C for more detailed information.

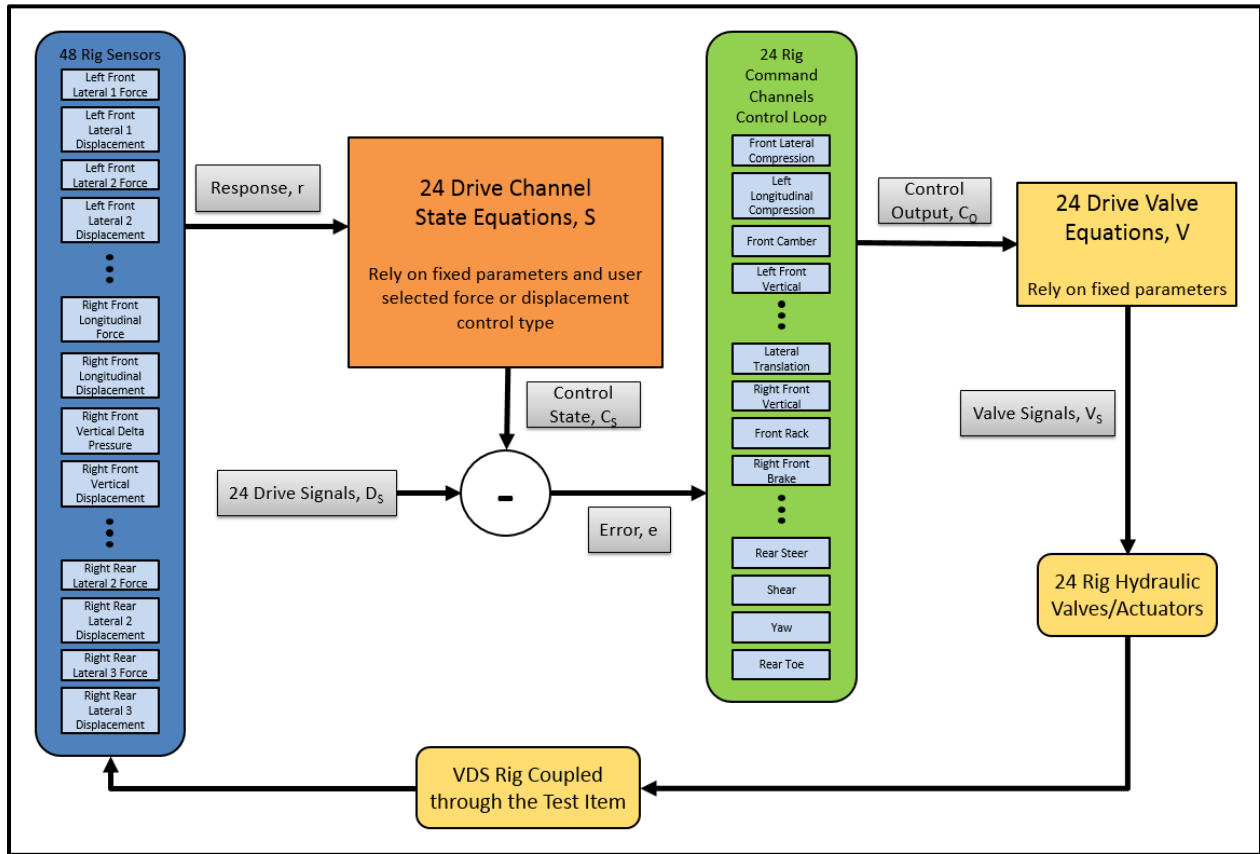

Figure 2. Graphical representation of the VDS control loop.

(2) The actuator control is managed through a schema of 24 separate Proportional-Integral-Derivative (PID) control loops which serve the basis of the drive channels. The control schemas can be modified to account for different test item arrangements and vehicle suspension geometries. A control schema can incorporate multiple actuators within one control loop in order to take advantage of cross coupling through the test item. The nature of the cross coupling depends on the item under test (e.g., solid axle vs independent suspension). The proper configuration of the control channels is an important aspect of running simulations on the VDS.

c. The simulator is controlled using MTS's remote parameter control (RPC) software. The software is specifically designed for the data collection, analysis, and simulation processes outlined in test procedure sections of this TOP. A technical discussion of the remote parameter control process and force versus displacement control for rig channels is presented in Appendix D.

d. The displacement and force capacities for each corner of the simulator are presented in Table 1. The current system capacities for accurate reproduction of test course profiles is presented in Table 2 for a whole vehicle, or single corner simulation. Testing vehicle, or axles above the system capacity is possible, but will result in the machine possibly not achieving the maximum moments and forces observed during field data collection.

TABLE 1. CORNER DISPLACEMENT AND FORCE RANGES

CHANNEL	DISPLACEMENT	FORCE
Vertical	15 in. (380 mm)	17,300 lbf (77 kN)
Longitudinal	15.4 in. (390 mm)	6,600 lbf (29.5 kN)
Lateral	10.2 in. (260 mm)	7,500 lbf (33.5 kN)
Camber	16 degree	5,090 ft-lbf (6.9 kNm)
Steer	34 degree	4,570 ft-lbf (6.2 kNm)
Brake	16 degree	8,330 ft-lbf (11.3 kNm)

in. = inch mm = millimeter
 lbf = pounds force kN = kilonewton
 ft-lbf = foot-pound force kNm = kilonewton meter

TABLE 2. VDS SYSTEM CAPACITY

ATTRIBUTE	MAXIMUM VALUE
Total Vehicle Weight (Free-Body Simulation)	20,000 lbs. (102.4 kN)
Corner Weight (Constrained Simulation)	8,000 lbs. (66.8 kN)
Vertical Suspension Travel	12 in. (355 mm)
Maximum Vehicle Track Width	105 in. (2667 mm)
Maximum Vehicle Wheelbase	225 in. (5715 mm)

3. REQUIRED TEST CONDITIONS AND LIMITATIONS.

The primary purpose of reliability testing using the VDS is to test the vibrational durability of a vehicle in an expedited, controlled, and cost effective manner. The excitation of the test item should be a reasonable representation of the types of vibrational inputs the system could be expected to endure during a lifetime of operations. The collected sensor data acquired during field testing needs to sufficiently characterize the expected vibrational inputs over the test items life cycle.

3.1 Test Planning.

a. Identify participating agencies, their roles and responsibilities in testing, and the Verification, Validation, and Accreditation (VV&A) process.

b. Determine the duration of the vibration environments derived from the item's Life Cycle Environment Profile (LCEP). The life cycle will include many different types of induced mechanical environments which may occur while the materiel is being handled, transported, deployed, and operated. Although all the induced mechanical environments are not critical in terms of generating potential damaging response amplitudes, they may contribute in varying

degrees to a materiel's fatigue damage. All expected exposure conditions should be tabulated, along with corresponding durations, to form the items LCEP. The scenario is a key parameter in the development of any vibration schedule. The vehicles Operational Mode Summary profile (OMS/MP) is broken down from paved, secondary and cross-county to the corresponding test courses. The profile is broken down further by determining the exposure time at each payload configuration. An example of a selected course break down is shown in Appendix A (Table A-1).

c. If the test failures will be used for reliability, availability, and maintainability (RAM) scoring then the failure definition scoring criteria (FDSC) need to be review beforehand. The vehicle technical manual should provide an inspection interval for the vehicle. If there is no inspection interval, or technical manual available, then an inspection interval and list should be generated with help from the evaluator, test sponsor, and vehicle vendor.

d. Develop a detailed test plan to include, instrumentation locations. Appendix A provides a basic outline for a VDS test plan. If the test item has known issues, make sure to install sensors to target the expected failure mode. If computer-aided design (CAD) and finite element analysis (FEA) models are available, utilize them to determine the best installation locations for strain gauge sensors. If the vehicle is equipped with an adjustable ride height system, then sensors will need to be installed to monitor the pressures in the shocks, or air bags.

e. If the vehicle is equipped with an adjustable ride height system, then a method to level and adjust the suspension (as necessary) on the VDS will be need to be determined. Work with the vehicle manufacturer to determine the specific needs of the vehicle system to ensure that the suspension is operating identically on the simulator and during field data acquisition.

f. If the test requires replication of steering system loads, then a spare power steering pump should be acquired from the test sponsor. The pump will be used external to the vehicle with an electric motor to pressurize the steering system when the vehicle is mounted on the VDS.

3.2 Test Preparation.

Upon arrival of the test item perform an initial inspection to ensure the system is in good working order. Use TOP 02-2-505³ as general guidance to ensure the vehicles functions satisfactorily. In addition, pay special attention to the following items:

a. Check that the tie rod ends, suspension ball joints, and bushings are in good condition and exhibit minimal wear. Verify that the compliance of the joints is within the manufacturer specifications, if available.

b. Check that the vehicle shocks and springs appear in good working condition. Verify shock/damper charge pressures versus the manufacturer specifications. The proper operation of the vehicle shocks is important to ensure collection of quality field data, as well as providing accurate replication of the field data on the VDS.

c. If the vehicle is equipped with a central tire inflation system, verify that the system is operating properly and the tire pressures fall within the manufacturer specifications for payload and terrain settings that will be used during testing.

3.3 Test Limitations.

a. A VDS test is considered a multiple degree-of-freedom (MDOF) simulation. Linear displacements along defined directions are referred to as translation DOF, and angular displacements along those same directions are referred to as rotation DOFs. Up to six DOFs exist for a rigid body (i.e., X-, Y-, Z-translations and roll, pitch, yaw rotations). Each VDS corner can control the spindle head in six DOFs. If a DOF is not measured during the data acquisition phase, then that DOF cannot be controlled during the laboratory simulation phase. Likewise, if the number and placement of actuators does not allow for influence over a DOF, then that DOF cannot be controlled.

b. Even when certain excitations and responses can be controlled, consideration should be given to the degree of control. Absolute control for either the frequency or time domains will always be impossible. Control within the frequency domain will always be band limited and may contain features such as notches or amplifications. Such inability to achieve absolute control is a feature of all shaker control systems, including single degree-of-freedom systems. For that reason, prior to testing, there should be an understanding of both the requirements to properly test the test item and the limitations of the VDS. The control limitations of the VDS may limit the ability to properly excite the test item. Generally speaking, for low frequency content, the limiting factor is the maximum system stroke; for middle range frequencies the limitation is the maximum system velocity; for higher frequencies the limitation is maximum system acceleration. The VDS maximum stroke is generally large enough for testing off-road military trucks. The maximum system velocity and accelerations are difficult to estimate because these will depend on the mass and weight distribution of the test item. Generally speaking, the VDS can sufficiently control an up-armored HMMWV (approximately 16,000 pounds (lb)) within the frequency range of 0.4 Hertz (Hz) to 50 Hz.

c. The VDS should not be expected to replicate real world inputs such as aerodynamic forces and excitations generated internally to the vehicle, such as vibratory noise from an onboard generator. The VDS does not replicate environmental factors such as water, mud, and extreme ambient temperatures.

d. Care should be taken when trying to compare real world endurance test results with VDS test results, especially for results such as mileage (simulated or real) between failures. Differences in results do not indicate a lack of validity in the simulation. The differences in results may be due to several factors, including but not limited to the initial condition of the test item, the degree of inspection and maintenance given to the test item during testing, and the greater variability associated with real-world RAM test process control. Real-world RAM testing can occur over a time period of several months, spanning multiple seasons. During that time period several aspects will vary:

- (1) Test course severity.

(a) Presence and significance of discrete features.

1 Potholes.

2 Bumps.

3 Ruts.

(b) Frequency domain content.

1 Broadband content.

2 Washboarding.

(2) Driver behavior.

(a) Path selection, feature avoidance.

1 Potholes, bumps, ruts, and washboarding.

2 “Walking the course”.

(b) Vehicle speed.

1 Overage features.

2 Average speed.

3 Speed distribution.

4. TEST PROCEDURES.

Testing with the VDS is a multistep process focused on field data acquisition, drive file development, and then test item life cycle evaluation. After the acquisition of test data, test time reduction techniques can be employed on the collected data to reduce the overall simulation time. Next, the field runs selected for replication are used to develop simulator drive files. Lastly, the drive files for each course are repeated in varying sequence to match the vehicle’s OMS/MP requirement.

4.1 Field Data Acquisition.

After determining the course and payload configurations for data collection, the next step is to instrument the vehicle and record data over the selected courses. The acquisition of quality data is important for reducing the processing time during the drive file creation process. To ensure the collection of quality data, use the following acquisition and data review procedures.

a. As discussed previously, a variety of instrumentation can be used in a VDS test set up. The list of instrumentation sensor types is provided in Section 2.1, as well as an example test plan with channel list in Appendix A. For the VDS system, the same instrumentation (acquisition equipment and sensors) should be used for both field testing and laboratory. The outputs from the instrumentation should be proportional to excitation in order to establish linear transfer functions within the control loop.

b. Refer to Appendix A for a sample test plan that was used for acquiring field data for testing of a vehicle on the VDS. The test plan includes a list of the courses to be run and corresponding speeds which represent the expected mission life of the vehicle. It is recommended to run each of the courses a minimum of three times to account for the variability of responses possible with each lap. When appropriate, some of the courses should be run three times in both directions because vehicle loading can be influenced by course direction. On courses where the length exceeds five miles, practicality may limit the number of laps to be achieved in the test time frame.

c. The plan also includes a channel list of sensors to be acquired during field testing. Not all channels acquired during field testing will be used in the VDS control loop, but rather will be used for informational purposes to guide data analysis and decision making. A reduced channel list can still allow for adequate control of the VDS test. The channel list should be dependent on the test-item and the purpose of the test. A list of critical channels should be developed to ensure that the minimum number of sensors required to develop a simulation drive file are captured during the field data acquisition. The critical sensors are required to be operational during all data acquisition runs. Acquisition sample rates and filtering should also be selected given test requirements. Data acquisition sample rates should be a minimum of 512 Hz with a low pass filter of 100 Hz or higher.

d. The vehicle should be stationary at the beginning and end of a data run for at least 10 seconds. During this stationary period the vehicle should be parked on level ground with the transmission in neutral and the driver's foot off the brake. The vehicle should be located at the same location on the test course for the beginning and end of the data run. This stationary period allows for evaluating the health of the transducers as well as creating a smooth transition for the drive file to start at and return to static equilibrium.

4.2 Data Review.

a. When in-service measurement data have been obtained, it is assumed that the data are processed in accordance with good data analysis procedures, as outlined in Multi-Shaker Test and Control IEST-RP-DTE022.1⁴ and Welch's method⁵. In particular, an adequate number of statistical DOFs have been obtained to provide information with acceptable statistical error. Consideration must be given to statistical error in all spectral estimates (auto-spectral density, cross-spectral density, transfer function, and coherence function estimates).

b. Ensure transducer placements have been addressed, to guarantee the desired motion DOFs may be resolved, and that common data validity checks are performed. It is important to

have an awareness of sensor location, orientation, and spurious sources of signal contribution. Adherence to a global coordinate system is also important.

4.2.1 Spectral Domain Review.

a. The Auto Spectral Density (ASD), or Power Spectral Density (PSD) is a frequency domain representation of a signal. The ASD is presented as scalar magnitudes as a function of frequencies. Specifically the ASD magnitude at a frequency represents the variance of the signal content at that frequency. Typically an ASD is constructed using Welch's method, which relies on the Fast Fourier Transform (FFT) to convert the time history signal into the discretized frequency domain. Welch's method also relies on user selected parameters such as block size (or frame size), the percentage overlap between blocks (e.g. 50%), and any optional scalar windowing to be applied to each block (such as the Hann window). The resultant ASD is essentially the average of the ASDs from each of the overlapping blocks. This averaging has the benefit of producing a smoother ASD function which may be a better representation of the original signal, however, it has an associated cost of possibly "averaging out" transient signal content which may only occur within a small number of blocks (or frames). An example time history and an associated ASD representation is presented in Figure 3.

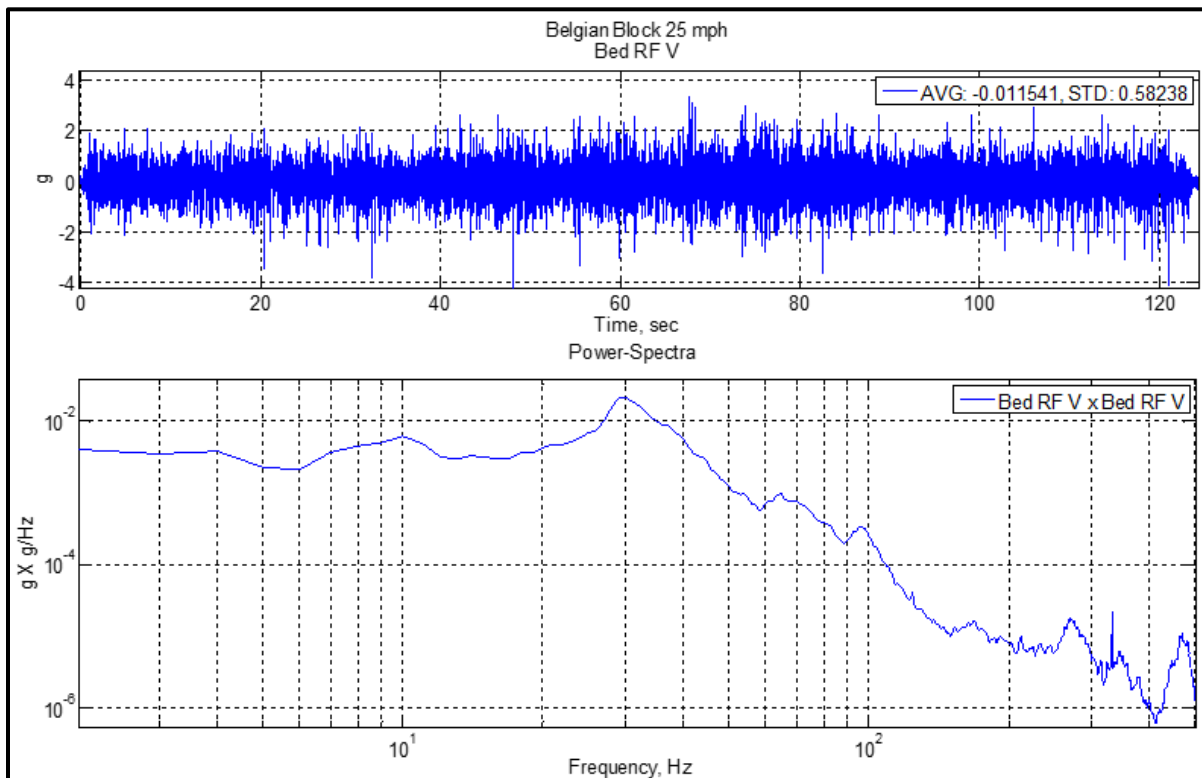

Figure 3. Example time history and corresponding PSD.

(1) Frequency domain representations are typically discretized, which means one must take into consideration the spectral resolution, or specifically the spacing between frequencies (otherwise known as the “delta-f” (Δf)). The Δf value is important for many reasons. Typically a spectral representation is only considered useful at frequencies greater than $2\Delta f$. Also it should be remembered the discretized PSD magnitude at a frequency, f_0 , represents the variance of the signal from frequencies $(f_0 - \Delta f/2)$ to $(f_0 + \Delta f/2)$. If the Δf is too large the ASD will lack resolution, which means any important signal content at f_0 could be too difficult to identify due to being averaged with the other frequency content contained within the $\pm \Delta f/2$ bin. The Δf can be determined (Equation 1) as the ratio between the time history sample rate, F_s , and the user selected block size, B :

$$\Delta f = \frac{F_s}{B} \quad (\text{Equation 1})$$

(2) A typical Δf value for work on the VDS is 0.25 Hz. This permits both good analysis of low frequency content and good spectral resolution for typical content of interest.

b. Once the ASD has been computed the data should be reviewed for all the channels determined as critical (paragraph 4.1 d) for the simulation. The review should look at the ASD over the simulation frequency range of interest, typically 0 Hz to 50 Hz. Sharp reversals or outlying peaks in amplitude may indicate a system resonance, or a transducer that is insensitive to input at those frequencies. Also review the ASD for symmetry to similar groups of sensors. For example, the left front and right front wheel vertical accelerations should look similar. If differences appear in sensors that should be similar, then further investigation is needed as to whether there is a sensor problem, or asymmetry in the test item response.

4.2.2 Time Domain Review.

a. The time domain review should look for common problems associated with data acquisition, such as drift, offsets, spikes, or dropouts in the data channels. Review the critical channels for simulation to ensure that no problems exist in the time domain that would cause issues for replication of the field data.

b. Statistical parameters should be used to evaluate the severity of a data run to include maximum and minimum values, average, standard deviation, percentile distributions, kurtosis, and crest factor. The statistical parameters of average, standard deviation, and kurtosis should be similar for symmetric sensors. An example of a symmetric sensors is the left and right front wheel accelerations.

c. Individual transient events, such as impact spikes caused by features such as potholes or bumps, are poorly represented by spectral estimates which are created by averaging many data blocks. These impact spikes may represent sharp loadings on the test item which could have a significant influence on fatigue damage history. Generally, loading contributions to damage are nonlinear, with larger loadings having a disproportionately greater contribution towards damage. Rainflow cycle counting techniques should also be used to assess the cycle amplitude and cycle mean of the signal content. This step is the precursor to estimating the relative damage

contributions from real world loadings that is performed during the drive file development process. Assessing the cycle count and comparing among runs on a similar test course helps in the selection process for determining the desired runs for simulation.

4.3 Drive File Development.

After the data have been reviewed and analyzed for any anomalies or irregularities, the selected field runs are used to create the desired response files. Any field data runs reviewed that had known issues in the critical simulation channels are discarded and other laps on the test course are considered for simulation. The candidates for the selected field runs are chosen based on the spectral, statistical, and time-domain review completed as outlined in Section 4.2. The field test data runs from individual laps on a test course will become the source files for individual drive files. A field test data run can potentially be over 600 seconds long. Given the number of repeats in the iterative process needed to develop accurate drive files, and the duration of an individual data run, often only an individual data run lap on a course can be used to represent the expected load and vibration inputs. Therefore, in order to create a conservative test (given a test item sample size of one), it is recommended that the most apparently “damaging” run on a test course be the source for the drive file that represents that test course. Lastly, the desired response files are created by several common data editing methods for reducing simulation time and removing benign data as outlined in the following procedures.

4.3.1 Selected Data File Editing Methods.

A reduction in laboratory test time is often referred to as “Accelerated Testing”. This term is often misunderstood. Accelerated as used in this reference simply means a reduction in test time, and does not necessarily involve an increase in loads applied to the test item. While there are many techniques to reduce test time, three relevant methods are discussed below. The purpose of the test and any specific durability concerns of the test item should be considered when deciding which test time reduction method will be used. It is often necessary to use a combination of the data editing techniques described in this section. When using multiple methods the overlap of selected sections from each time history are often combined to maintain a conservative approach to the retention of data for simulation.

4.3.1.1 Fatigue Damage Editing.

a. The fatigue damage editing method uses strain and/or force based sensors on the test specimen to determine the damaging regions of the data. The strain sensors are the most direct method of correlating vehicle response to structural stress and damage. Fatigue damage editing involves analyzing the time history of the data signals and eliminating those sections of data runs which are considered to have minimal contribution to the damage of the test specimen. Performing a time-waveform replication of only the damaging inputs reduces simulation time and provides results on the system reliability much sooner than a traditional field endurance test.

b. The RPC Pro software used extensively with MTS 329 machines, has many processes for analyzing data to reduce the amount of simulation time. The goal of the fatigue editing process is to remove non-damaging portions of the field data and only simulate data that causes

“damage” to the desired test specimen. Using the RPC “Auto Damage Editor” tool the strain response channels are processed to remove the benign sections of field test data. The tool requires user inputs of damage retention, or desired file time reduction. It then auto calculates and determines a threshold for removing sections of data. An example of data processed with this tool and selected damaging regions highlighted in blue is presented as Figure 4.

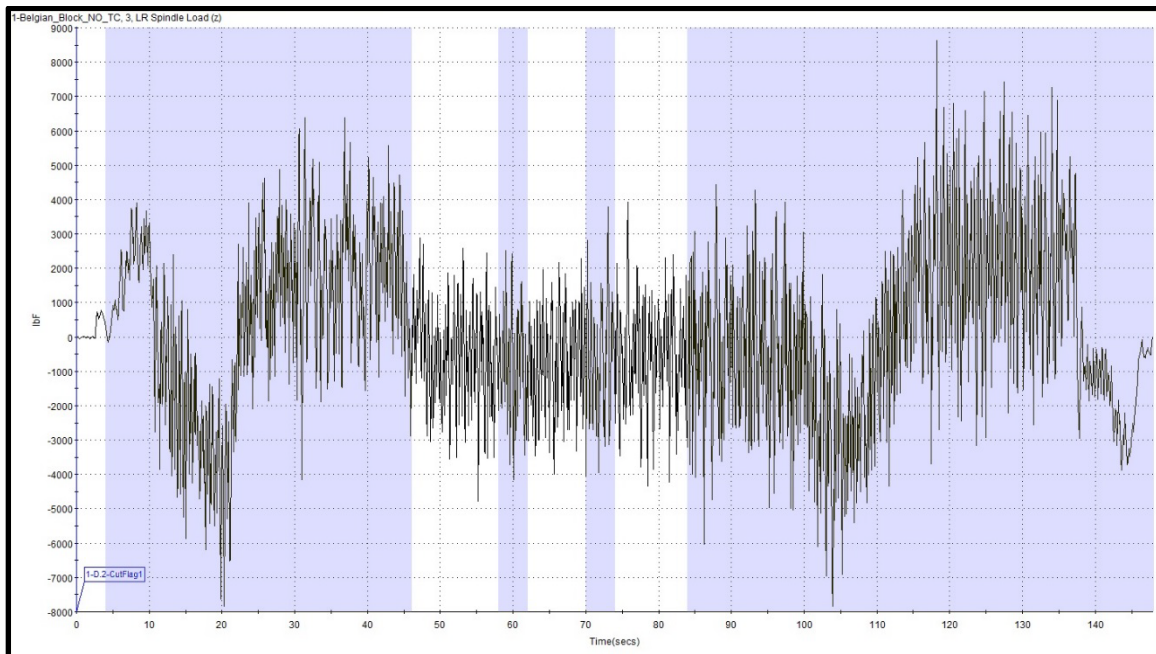

Figure 4. Example of file region selection based on fatigue damage.

c. The damage time history tool is used in the auto damage editor to associate fatigue damage to specific events in the data file. The relation of damage and time is required to effectively remove benign portions of the data. Rainflow cycle counting is an algorithmic process with different versions in common usage that, depending on the application, could give very similar results. The rainflow counting algorithms focus on the range changes between the peaks and valleys of the irregular time history. For a detailed description of the rainflow cycle counting process, refer to Appendix B or American Society for Testing and Materials (ASTM) E1049-85⁶. The rainflow algorithm used by RPC Pro software performs counts of half-cycles. A half-cycle is defined as a range change which is smaller than the immediately preceding and subsequent range changes. Once a half-cycle range is identified, its associated peak and valley are removed from the peak-valley history, and half-cycle search is begun anew on the reduced history. Whole cycles are identified as a pairing of loading and unloading half-cycles of equal magnitude. This process leads to many instances of *residual* half-cycles for which an equal magnitude pairing cannot be made.

d. Practices vary as to how to handle the residual half-cycles. The VDS analysis software generates a Damage Time History (DTH) which treats a half-cycle as “damaging”. A

DTH is a time sequence of damage which can be identified from a data channel. The damage associated with a half-cycle is considered to be half the damage associated with a full cycle. This is a sufficiently reasonable practice considering that most VDS time histories are oscillations about a mean, beginning and returning to the same value. This implies that there are generally an equal number of loading and unloading half-cycles, though of slightly differing magnitudes. (Histogram based counting methods benefit from being able to group half-cycles in the same bin, meaning the ranges do not need to exactly match to be paired as a full cycle).

e. The DTH can be presented as either a series of spikes in time, with each $0.5/N_{fi}$ spike associated with a half-cycle, or as a cumulative sum of these $0.5/N_{fi}$ spikes, which appears as an irregularly spaced pattern of unequal height steps. Caution should be used when interpreting these spikes in time. It is easy to understand that a cycle spans a time range. However, the time spans of the cycles identified in the rainflow cycle algorithm are not readily apparent by simply looking at the original time history. The timing of the extrema is obviously important, but “Damage” should not be considered a perfectly localized phenomenon for most events. However, damage can be generally localized to a time region (e.g., damage occurring due to a pothole in an otherwise smooth road.) A DTH is a useful tool for identifying the time regions which are likely to be more relatively damaging, assuming the scale factor and material selections are valid. Using the fatigue editing tool the selected time history files can be edited to remove “non-damaging”, or benign sections of input. This region contributes minimally to the wear of the test item and can be removed to decrease the simulation time. Historically when creating simulation files for the VDS using the auto damage editor the objective has been to retain at least 90 percent of the fatigue damage as compared to the field test data.

4.3.1.2 Relative Damage Estimate.

a. The Relative Damage Estimate (RDE), sometimes called the “Pseudo-fatigue Damage”, is an analysis technique intended to enable relative severity comparisons between different time segments of a response channel. The time segments under comparison can be within the same data run or within separate time histories. The technique is called pseudo-fatigue damage because it is often used with sensors that are not appropriate for assessing material damage (such as accelerometers) rather than more traditional sensors (such as strain gages). The implication is that the analysis results are not a correct estimate of fatigue damage, though it is recognized that the results could be used to assess relative severity. The method is based on the traditional fatigue damage estimates relying on strain measurements, knowledge of material properties, rainflow cycle counting, assumptions of Miner’s Rule, and a presumed fatigue-damage model.

b. The typical fatigue damage model used is the Smith-Watson-Topper (SWT) formula (Equation 2), which defines the following relationship between the number of cycles to failure, N_f , and the experienced peak stress, σ_{max} , strain amplitude, ϵ_a , and the material properties such as Young’s Modulus E and fatigue specific properties, σ'_f , ϵ'_f , b , and c :

$$\sigma_{\max} \varepsilon_a = \frac{(\sigma'_f)^2}{E} (2N_f)^{2b} + \sigma'_f \varepsilon'_f (2N_f)^{b+c} \quad (\text{Equation 2})$$

c. The material properties are associated with the user-selected material in the VDS control software (RPC Pro). Some example SWT load-life curves are presented in Figure 5. A cyclic life curve, such as a SWT curve, presents the number of cycles which can occur prior to failure at a given load cycling. Obviously more cycles can be achieved if the loading is less severe (lower peak and/or lower amplitude).

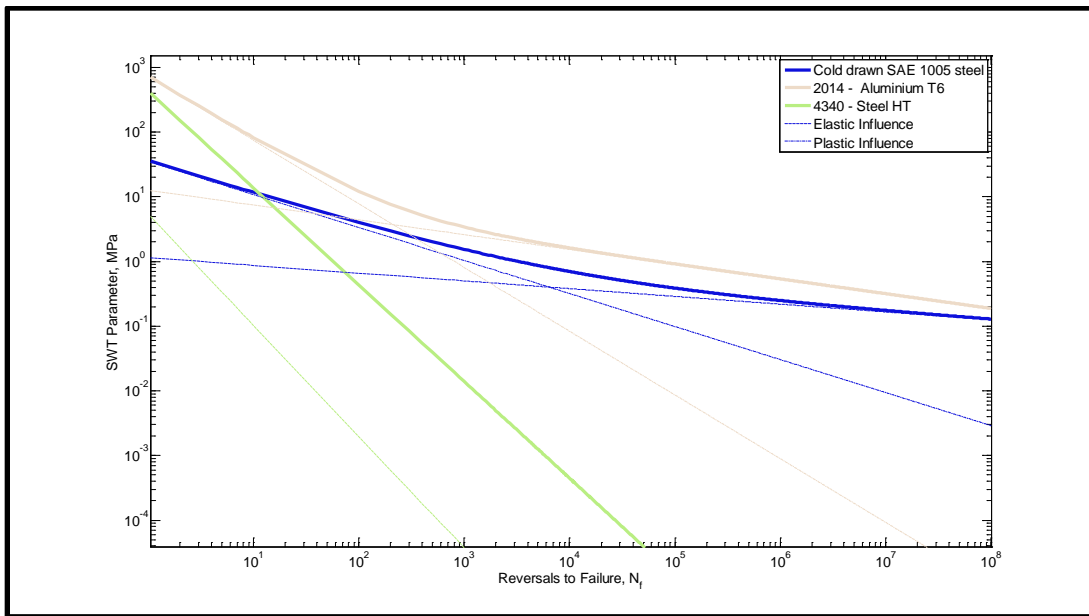

Figure 5. Smith-Watson-Topper cyclic life curve.

d. In practice, the material properties are never known. However, the material choice is not very important because the RDE is not attempting to characterize the actual damage but simply the relative severity. Generally, a material has a threshold loading level below which it is presumed failure will never occur regardless of how many cycles are applied. When performing RDE, a scale factor is typically applied to a signal to produce pseudo-load ranges large enough to be considered cyclic fatigue inducing. This is especially important with a sensor such as an accelerometer which typically measures values on a scale of 10 g's as opposed to a strain gauge measuring hundreds of microstrain. The scale factor can be different for two different channels, but the scale factor for a given channel must be consistent across all data runs to provide for valid relative comparisons.

e. It should also be recognized that a load-life curve, such as SWT, consists of two distinct regions. The lower cycle count region is dominated by plastic strain inducing loads,

while the higher cycle count region is dominated by elastic strain inducing loads. Applying a larger scale factor will raise the pseudo-loading past the elastic region into the plastic region. The transition from elastic to plastic dominated strain life is a non-linearity which results in the method being even more sensitive to larger amplitude signals. There may be some benefits to doing this, depending on the application and the test item being monitored. However, assessing the overall distributions of signal amplitudes amongst all data runs and determining the appropriate scale factor can be an onerous task considering the high channel counts of typical VDS tests. It may be more prudent to choose a pseudo-material which has a negligible transition from elastic to plastic dominated strain life, such as High Tensile Strength Steel 4340. Regardless of the material choice, the scale factors chosen should be low enough that the cyclic load-life models do not imply failure at extremely low cycle counts.

f. Cyclic load-life models give the number of cycles to failure, N_f , at a given loading. But true test loads will have irregular cyclic patterns, with the “cycles” not necessarily being clearly identifiable. For this reason, RDE relies on rainflow cycle counting to identify individual cycles within the irregular patterns. The mean and amplitudes of those individual cycles are then used with the assumed material properties and load-life model (SWT) to calculate N_{if} , which is the number of cycles until failure at that mean-amplitude combination. The damage contribution from each cycle identified will be assessed in accordance with Miner’s rule. Miner’s rule states the total damage to an item due to irregular loading is equal to the sum of proportional damage done at each cycle type, D_i , with D_i being the ratio of counted cycles, N_i , to the number of cycles to failure N_{if} (see Equation 3):

$$D_T = \sum D_i = \sum \frac{N_i}{N_{if}} \quad (\text{Equation 3})$$

g. Therefore, it follows that the damage contribution from each individual cycle identified will be assessed as $1/N_{fi}$, with N_{fi} being calculated from the load-life model (SWT) using the mean and amplitude of the scaled cycle.

h. Once the selected channel has been properly scaled into a pseudo-damage channel the analysis process described in Paragraph 4.3.1.1 is used to remove benign portions of data and reduce the necessary simulation time.

h. A similar method with custom parameters was developed by engineers at the U.S Army Tank Automotive Research, Development and Engineering Center (TARDEC)⁷. The reference lays out a pseudo damage method for editing data for a simulator that applies vertical inputs to the vehicle tires.

4.3.1.3 Statistical Region Selection.

A third method used in reducing the simulation time from the raw field data includes the use of the statistical region selection tool in RPC. The statistical region tool can be used to

perform statistics calculations over moving windows in the file. In previous testing correlations between the standard deviation of forces measured by wheel force transducers and structural fatigue was observed. Therefore, in some cases, the standard deviation of vertical force and lateral force measured from the wheel force transducer in a four second window is used to help reduce the simulation file length. Since force is typically a linear correlation to strain on a structure, the use of force to help cut drive file length can be used as a secondary method in the absence of actual strain data. Typically the standard deviation of vertical force over the 4 second window is set to 20% of the wheel weight as a starting point. The value is then adjusted based on the results to provide a conservative reduction of the simulation file time.

4.3.2 Desired Response File Filtering and Signal Decomposition.

a. After the desired response files have been edited to remove benign portions of the data, the next step is to filter the files to remove low frequency content. Typically the lower cut-off for data is 0.4 - 0.5 Hz depending upon the selected frequency domain properties. Signal decomposition is a process which transforms a group of time histories into another group of time histories which provide a more advantageous representation. Individual channels in the new group can then be filtered before transforming the new group back into a modified version of the original group. The VDS drive file development process uses signal decomposition to mitigate the problem created by the fielded test item being measured while completely unconstrained but tested on the rig with constrained displacement capabilities. The problem is most pronounced for force and acceleration measurements made in the horizontal plane.

b. An example would be to decompose two front lateral wheel force channels, F_{y1} and F_{y2} , into lateral compressive and lateral translational forces, F_{fC} and F_{fT} . A compressive force is internally reacted by the vehicle structure, where as a translational force would cause a free-body acceleration. After decomposing the lateral force a high pass filter is applied to F_{fT} , resulting in F_{fT_hp} . A frequency based high-pass filter is typically used. The filter works by computing a FFT and then zeroing out the FFT bins below the cut-off frequency. After zeroing out the low frequency content, an inverse (ifFT) is applied to reconstruct the time history signal. The filter cut off frequency is set high enough so that the final drive translational forces will not be commanded to push the test item farther than the displacement constraints of the rig, when trying to replicate near-static force events, such as turns or driving on laterally sloped surfaces. If compressive forces acting on the front axle do not result in the hardware limits being exceeded then F_{fC} should remain unfiltered in order to retain any effects those forces may have on the test item. F_{fC} and F_{fT_hp} are then recombined (“recomposed”), resulting in a modified time history of the lateral wheel forces, F'_{y1} and F'_{y2} . It is these modified channels that are used in subsequent analysis and drive file development.

c. The advantages of signal decomposition are apparent when compared to the more direct approach of simply high pass filtering each individual channel from the original data set. Simply high pass filtering the unmodified F_{y1} and F_{y2} would result in removing compressive forces which can be simulated in order to retain greater integrity to the collected data.

d. The signal decomposition approach for handling translational and compressive forces can be expanded for other channel combinations, such as the rear axle lateral forces and the

longitudinal forces acting on the left and right sides of a vehicle. The matrix based relationships between spindle forces and the control channels are presented in Equations 4 through 7.

$$\begin{bmatrix} \textit{Lateral Translation} \\ \textit{Front Lateral Compression} \\ \textit{Rear Lateral Compression} \\ \textit{Shear} \end{bmatrix} = \begin{bmatrix} 1 & 1 & 1 & 1 \\ -1 & 1 & 0 & 0 \\ 0 & 0 & -1 & 1 \\ -1 & -1 & 1 & 1 \end{bmatrix} * \begin{bmatrix} \textit{LF Fy} \\ \textit{RF Fy} \\ \textit{LR Fy} \\ \textit{RR Fy} \end{bmatrix} \quad (\textit{Equation 4})$$

$$\begin{bmatrix} .25 & -.5 & 0 & -.25 \\ .25 & .5 & 0 & -.25 \\ .25 & 0 & -.5 & .25 \\ .25 & 0 & .5 & .25 \end{bmatrix} * \begin{bmatrix} \textit{Lateral Translation} \\ \textit{Front Lateral Compression} \\ \textit{Rear Lateral Compression} \\ \textit{Shear} \end{bmatrix} = \begin{bmatrix} \textit{LF Fy} \\ \textit{RF Fy} \\ \textit{LR Fy} \\ \textit{RR Fy} \end{bmatrix} \quad (\textit{Equation 5})$$

$$\begin{bmatrix} \textit{Longitudinal Translation} \\ \textit{Left Longitudinal Compression} \\ \textit{Right Longitudinal Compression} \\ \textit{Shear} \end{bmatrix} = \begin{bmatrix} 1 & 1 & 1 & 1 \\ -1 & 0 & 1 & 0 \\ 0 & -1 & 0 & 1 \\ 1 & -1 & 1 & -1 \end{bmatrix} * \begin{bmatrix} \textit{LF Fx} \\ \textit{RF Fx} \\ \textit{LR Fx} \\ \textit{RR Fx} \end{bmatrix} \quad (\textit{Equation 6})$$

$$\begin{bmatrix} .25 & -.5 & 0 & .25 \\ .25 & 0 & -.5 & -.25 \\ .25 & .5 & 0 & .25 \\ .25 & 0 & .5 & -.25 \end{bmatrix} * \begin{bmatrix} \textit{Lateral Translation} \\ \textit{Front Lateral Compression} \\ \textit{Rear Lateral Compression} \\ \textit{Shear} \end{bmatrix} = \begin{bmatrix} \textit{LF Fx} \\ \textit{RF Fx} \\ \textit{LR Fx} \\ \textit{RR Fx} \end{bmatrix} \quad (\textit{Equation 7})$$

e. After applying the signal decomposition process the rest of the desired response channels that rely on inertial reaction should be high-pass filtered at the selected cut-off frequency. Typically, all the accelerometers channels, as well as the vertical force measurement from the wheel force transducers, are high-pass filtered.

4.3.3 Frequency Response Function (FRF) Drive File Creation and Review.

A FRF for each test configuration identified in the mission scenario will need to be computed. Differences in weight, weight distribution, and suspension characteristics would constitute different test configurations.

a. Drive files themselves do not refer to sensor signals installed on the test item. The influence of the sensors installed on the test items come from the outer control loop process as the reference channels for the desired time histories. The relationship between the outer loop response reference channels and the drive channels comes from the FRF. The drive channels are governed by an inner PID loop intended to minimize the error between the actual state and the reference signal in the drive file. The adjustment of any inner or outer loop PID values should be completed before determining the system FRF. Altering the PID values after the FRF will

invalidate any rig-test-item characterizations and undermine the system's ability to achieve the desired responses. It is good practice to verify the outer loop PID settings when a new test item is placed onto the VDS. The interaction of the rig and test item usually requires an update to the outer loop tuning parameters.

b. The FRF must be developed by shaking the test item with broadband content while measuring the responses of the operator selected reference channels. The goal of the FRF is to shake the test specimen hard enough to develop a good characterization of the response to average magnitude inputs, while not imparting loads outside those seen during the field data collection. The operator has five means of influence of this process:

- (1) Setting up the drive channels.
- (2) Setting the magnitude of the broadband content, for each drive channel.
- (3) Setting the shape of the broadband content, for each drive channel.
- (4) Selecting the response channels.
- (5) Determining the frequency bands which the response channels influence.

c. The VDS can support up to 24 drive channels. Different drive channels are established in the VDS by combining different rig sensors and actuators within one control loop. This process is discussed in Paragraph 3.1. Typically the drive channel arrangements are not adjusted except for fixed parameters related to the vehicle dimensions (e.g., axle spacing and track width).

d. The magnitude and shape of the broadband content determines how much a drive channel will excite a test item at a given frequency. The frequency content of each drive channel is separately determined by a shaping exponent, n , a break frequency f_b , and an upper cut off frequency, f_c . Between f_b and f_c the frequency content decreases by $1/f^n$. Below f_b the frequency content is equal to the magnitude at f_b . The magnitude is determined by scaling the generated signal so that three standard deviations ("*3-Sigma*") of the signal is equal to an operator set value. The *3-Sigma* value is expected to be the approximate maximum amplitude of the generated signal. The operator usually chooses these settings by considering the nature of the sub-system being most directly excited by the drive channels. As an example, the left front corner vertical displacement drive channel will most directly excite a test item's left front wheel displacement. The relationship between the left front vertical drive and left front corner vertical wheel dynamics is best described when the wheel displacement is caused to move through a significant portion of its possible range of motion. Judging large displacements at lower frequencies to be more important (in order to achieve larger wheel displacements) would lead the operator to use a larger shaping exponent, such as $n = 2$. The shaping parameters and magnitude settings should be considered concurrently. This is because the *3-Sigma* value is related to the area under the spectral curve. Maintaining the same *3-Sigma* value while changing the exponent from $n = 1$ to $n = 2$ will lower the higher frequency content while significantly raising the magnitude at f_b .

e. When determining a drive channel's broadband excitations, the operator must also keep in mind the nature of the what is being controlled and how it will manifest itself at higher (or lower) derivatives. The second derivative of a displacement channel is acceleration. In the frequency domain the second derivative of a signal is calculated by multiplying the content by $(2\pi f)^2$. This means that the spectral content of a driven displacement signal shaped by $n = 2$ will have an acceleration action of $n = 0$, otherwise known as white noise. Exciting a displacement controlled drive channel with content shaped by values less than $n = 2$ may result in accelerations which are deemed too harsh.

f. The selection of the response channels and the frequency bands which they influence is also a very important step. Each control band must have at least as many response channels, N_{rb} , as drive channels, N_D . A linear best fit approach is used when a control band is over defined ($N_{rb} > N_D$). Experience and familiarity with the test item will guide the response channel selection. Sensor type and location must be taken into consideration. A given sensor will be better at describing some frequency bands than others. The sensor mounting location should be considered to ensure some portions of the test item are not excessively characterized while other portions are inadequately characterized. MDOF coherence analysis should be employed to review the effectiveness of the selected response channels in describing the test item, within its assigned control band, after the shape noise shake is performed and the FRF is developed.

g. There may be a need to perform multiple attempts at developing the FRF given the information learned from the previous attempts. Subsequent attempts may show improvements by adjusting any aspect of the operation parameters in items Paragraphs 4.3.3.b(1) - (5). Unfortunately the FRF development process cannot be optimized given the complexity of the typical test items, the variety of test items which can be tested, and the need to limit the damage that could be done by the FRF shake. Fortunately some of the arbitrary influence of an operator's subjective judgment is mitigated by the corrections made in the iterative drive file development process.

h. Because the initial drive file development and iterative improvements come from the FRF inverse, the response channels should provide a means of describing the drive channels. The FRF provides, in the frequency domain, a linear relationship between an input channel and a response channel. Ideally the only source of response channel signals will be from the drive channel excitations, though this ideal will never be achieved.

i. Care should be taken when two response channels are correlated, such as two vertically oriented accelerometers physically located in the same area of the test item. The correlation between signal i and signal j may simply be due to the fact that the response signals are being concurrently driven, or with a lossless transfer from response i to response j . In this situation the response j signal adds no extra information about the drive signal. Generally this situation can be recognized with familiarity about the system under test and only using one of the signals for the inverse FRF model.

j. An effort should be made to identify resonant driven responses, which will show up as distinctive peaks and valleys. This is not only because these features comment on the nature of

the test item (or coupled system of the test item attached to the VDS rig), but they also have a strong influence on how well the system can control those frequencies. The FRF magnitude and phase values are only estimates influenced by many sources of noise, with the error in those estimates being most important at frequencies to which the system is most sensitive, such as modal frequencies (peaks). Valleys in an FRF can also be influential because the inverse of the FRF at the valley will have a large magnitude. A small imprecision in estimating the FRF magnitude at the valley could have a significant influence on the inverse FRF magnitude. These errors will have an influence in the subsequent drive file development. The content of the FRF may require an adjustment of the test configuration setup, which would then require developing a new FRF.

4.3.4 Creating the Inverse FRF.

Once the FRF has been created the next step in the process is to define the inverse FRF, which will be used to create the initial drive file. The inverse FRF defines the frequency range and response signals used in calculating the machine drive signals. A good method for the initial setup of the inverse FRF is to determine which response signals will have the strongest correlation to the drive signals. An example layout with an initial map of correlation between response and drive signals is presented in Figure 6. The light yellow represents a weak correlation and the orange represents a strong correlation. This is an important first step in the organization of the process for creating the inverse FRF. The next step is to determine the frequency bands that will be used for control. Depending upon the setup, the first band is 0-0.5 or 0-0.4 Hz. In the first band the drive channels that use displacement units, or relate to translation movement of the body, are removed from control. The filter cut off frequency should be set high enough so that the final drive translational forces will not be commanded to push the test item farther than the displacement constraints of the rig when trying to replicate near-static force events, such as turns, braking, or driving on laterally sloped surfaces. Depending upon the frequency content of the simulation the engineer may decide to use different response channels across different frequencies. As an example the wheel displacement sensors are typically used at lower frequencies, but then transition to the spindle accelerometers at higher frequencies for control. Another practice to avoid is using multiple sensors to control an input in the same frequency range. The overlap averages the error from each sensor to create a drive file that does not correlate within the expected error bounds to either sensor. The over constraint in the inverse FRF generation can reduce the fidelity of the simulation. Instead it is recommend to use strongly correlated response channel for each frequency range.

		Drive Channels																				
		LF Vert.	RF Vert.	LR Vert.	RR Vert.	Front Lat. Comp.	Rear Lat. Comp.	Lat. Trans.	Left Long. Comp.	Right Long. Comp.	Long. Trans.	Shear	Yaw	Front Toe	Front Steer	Rear Toe	Rear Steer	Front Camber	Front Rack	Rear Camber	Rear Rack	
Response Channels	LF Spindle Load Z	■																				
	RF Spindle Load Z		■																			
	LR Spindle Load Z			■																		
	RR Spindle Load Z				■																	
	LF Hub Z Spindle Accel	■																				
	RF Hub Z Spindle Accel		■																			
	LR Hub Z Spindle Accel			■																		
	RR Hub Z Spindle Accel				■																	
	LF Wheel Displacement	■																				
	RF Wheel Displacement		■																			
	LR Wheel Displacement			■																		
	RR Wheel Displacement				■																	
	LF Spindle Load X								■													
	RF Spindle Load X									■												
	LR Spindle Load X										■											
	RR Spindle Load X											■										
	LF Spindle Load Y						■															
	RF Spindle Load Y							■														
	LR Spindle Load Y								■													
	RR Spindle Load Y									■												
	LF Spindle Moment X																		■			
	RF Spindle Moment X																			■		
	LR Spindle Moment X																				■	
	RR Spindle Moment X																					■
	LF Spindle Moment Z															■						
	RF Spindle Moment Z																■					
	LR Spindle Moment Z																	■				
	RR Spindle Moment Z																		■			
	LF Hub X Spindle Accel									■												
	RF Hub X Spindle Accel										■											
	LR Hub X Spindle Accel											■										
	RR Hub X Spindle Accel												■									
LF Hub Y Spindle Accel													■									
RF Hub Y Spindle Accel														■								
LR Hub Y Spindle Accel															■							
RR Hub Y Spindle Accel																■						
LF Hub Y Steer Accel																						
RF Hub Y Steer Accel																						
LF Tie Rod Axial Load																						
RF Tie Rod Axial Load																						
LR Toe Link Axial Load																						
RR Toe Link Axial Load																						

Figure 6. Map of relationship between drive and response channels.

4.3.5 Iterative Drive File Development.

a. The initial drive file contains the drive channel time histories intended to create the desired responses which are representative of field data. The initial drive file is created by sending the desired response data through the inverse of the FRF. In order to be improved upon the initial drive file must first be run (shaking the test item) in order to measure the test item response channels. The response error is then scaled by a user selected scale factor before being sent through the FRF inverse to create an incremental change to be added to the previous drive file. The new drive file is then used to shake the test item, resulting in a new set of response channel measurements to be compared against the desired responses. This incremental process is repeated until the operator ceases the process and concludes with the final drive files.

b. The user selected scale factors influences the rate at which the incremental process arrives at the final drive. If the scale factors are small then many iterations will be needed. If the scale factors are too large then the incremental changes may be too large, resulting in more error in the new iteration. It should be noted that different scale factors can be set for different drive channels, with the scale factors being adjustable between iterations. Scale factor selection is not an optimized process. The process is complicated by the system responses and drive channels

being coupled in ways not completely accounted for by the FRF. The channel coupling could result in a situation where some results channels are incrementally improving while other results channels are incrementally worsening. Generally the operator relies on knowledge of the system and a review of iteration error trends to adjust the scale factors during the drive file development process. This knowledge is used to change specific scale factors in order to allow specific response channels an opportunity to improve without being driven towards error by changes in other channels. The ad-hoc nature of drive file development is taken into account by considering each iteration run in the overall accounting of loading exposure, as is discussed in Section 5. The error limits for the desired versus simulator response can vary by test requirements, test item, and number of control degrees. The drive file iteration process is usually considered complete when two error criteria are met. First the ASD of critical response channels should not deviate by more than 3 decibels (db) over the frequency range of simulation. The ASD should not be used for review of discrete events such as half round hits, or curb strikes. The second error criteria is the root mean square (RMS) error of the monitored channel versus the desired channel has reached an acceptable limit for simulation fidelity. The RMS error is defined in Equation 8.

$$RMS \text{ error percent} = \frac{RMS(Desired \text{ Response} - Simulation \text{ Response})}{Absolute \text{ Max}(Desired \text{ Response})} * 100 \quad (Equation \ 8)$$

c. The typical channels evaluated for RMS error are the wheel forces and moments. The typical minimum expected RMS error value by critical channel type are provided in Table 3.

TABLE 3. TYPICAL SIMULATION FILE RMS ERROR VALUES

CHANNEL	MINIMUM RMS ERROR (percent)
Spindle Load Z	10
Spindle Load X	15
Spindle Load Y	15
Spindle Moment Z	20
Spindle Moment X	10

5. LIFE CYCLE TESTING.

5.1 General.

a. After creating the machine drive files it is time to begin the specimen life cycle testing. An ensemble of drive files is developed to represent a full variety of plausible inputs which were determined to cause damage to the test item. The sequence in which the drive files will be run should attempt to reflect actual operational usage. Generally the file sequence should reflect the LCEP and OMS/MP breakdown, with a reasonable apportioning within each mission block. A

drive file run log should be maintained beginning with the first drive iteration, with each record containing the following: date and time of the drive initiation, name of the represented terrain, drive file iteration number, FRF reference name, and distance represented by the drive file.

b. Vehicle reliability is the expected duration or probability to have failure-free performance under the stated test conditions. Typically, reliability metrics are discussed in terms of distance, or operating time. A distance should be associated with each drive file to determine a comparable reliability metric when using the VDS. However, the distance a drive file represents is not simply determined by the distance traveled in the original source file. This is because the relative damage induced in a drive response file will not equal the relative damage from the original source file recorded in the field. See paragraph 4.3.1.2 for more detailed information about RDEs. The distance represented by a drive file, d_D , is determined by (Equation 8): where d_F is the distance traversed in the original field data source file, D_D is the RDE for an ensemble of response channels excited by the drive file, and D_F is the RDE for the same ensemble of response channels excited in the field.

$$d_D = d_F \frac{D_D}{D_F} \quad (\text{Equation 8})$$

c. Furthermore, the drive file development process will have different degrees of damage retention for different localities within the test item, especially for a test item as complicated as a military vehicle. For this reason a drive file may be considered to represent different distances for different localities within the test item. If the relative damage exposure to locality k is represented by N_k channels, then the RDE for locality k , D_k , is (Equation 9): where D_j is the RDE for channel j and w_{kj} is the weighting of the j th channel for its contribution to the ensemble of N_k channels. (If the same channel, j , is included in the ensemble of channels for another locality, m , then it will have a different weighting. e.g. $w_{kj} \neq w_{mj}$). The distance represented by a drive file for locality k is (Equation 10): where d_F is the distance traversed in the original field data source file, D_{Dk} is the RDE for location k excited by the drive file and D_{Fk} is the RDE for the location k excited by field operations. Lastly, an overall representative distance for the entire test item can be determined by a broad selection of channels in conjunction with Equation 1. While the overall representative distance is a useful metric for general test management, the relative damage exposure to the various localities should always be kept in consideration and presented in the final reporting.

$$D_k = \sum w_{kj} D_j, \quad \sum w_{kj} = 1 \quad (\text{Equation 9})$$

$$d_{Dk} = d_F \frac{D_{Dk}}{D_{Fk}} \quad (\text{Equation 10})$$

5.2 Test Control Limits.

The VDS drive inputs and test item responses should be continually monitored for validity throughout testing. Maintaining the test inputs is complicated by the test item being integrated into the full test rig. Because the purpose of the test is to evaluate the durability of the test item, it is expected that the mechanical compliances, internal coupling, and nonlinearity will change during testing as the vehicle components degrade due to wear. When the compliance increases, the force controlled drive channels will need greater displacements to achieve the same forces. Similarly when the compliance decreases, the displacement controlled drive channels will require less force to achieve the same displacements. Because of this the test monitoring approaches used in a VDS test should not necessarily be the same as those used in MDOF shaker table tests. Refer to TOP 01-2-602⁸ for suggested guidance for MDOF table tests with stationary, broad spectrum and Gaussian excitation. Also, because VDS testing can be considered a Time Waveform Replication (TWR) test, refer to MIL-STD-810G CN1 (Method 525.1) for guidance on TWR testing. These references can be informative but do not encompass all the necessary guidance for setting test control limits on the VDS. The test control regime should not require responses or inputs to remain exactly the same throughout the test. Instead the control regime should require the inputs remain as reasonable approximations to the inputs that would be seen during a field endurance test. The question for control limits is to determine the degree to which the VDS inputs should be allowed to vary, just as the non-concrete courses used in a field endurance test are permitted to vary. The recommended method is to use the trend monitoring feature within the RPC Pro software testing modules. The trend monitoring reference files are created on the first run of each unique course and payload combination after drive file development has been completed. The initial response reference files are then used for comparison throughout the life cycle simulation. The trend monitoring is set to warn the operator or stop the simulation if the RMS of the acceleration, force and/or strain channels exceed specified limits. The typically limits for a simulation are set to warn the operator if values vary by more than 10 percent from the reference files.

6. PRESENTATION OF DATA.

The final data product format should be discussed with the customer and evaluators prior to the conclusion of the test. Tables 4 and 5 show examples of how simulator data summary and results can be presented.

TABLE 4. EXAMPLE ACCELERATED DURABILITY TEST SCHEDULE, WITH COMPRESSION

Usage	Course	Course Length, Simulated		Average Course Speed		Time Compression, Percentage	Distance Simulated	
		km	mi	km/hr	mph		km	mi
Not Simulated	Paved	9.94	5.99	80.5	50.0	100.0	0	0
	Secondary #1	3.54	2.20	56.3	35.0	100.0	0	0
	Secondary #2	7.93	4.93	56.3	35.0	100.0	0	0
	Secondary #3	2.82	1.75	48.3	30.0	100.0	0	0
	Gravel A	3.69	2.29	48.3	30.0	100.0	0	0
ATC Courses	Gravel B	3.48	2.16	48.3	30.0	40.0	2,092	1,300
	Belgian Block	1.30	0.81	40.2	25.0	30.0	322	200
	Cross Country #1	2.43	1.51	24.1	15.0	50.0	3,018	1,875
	Cross Country #2	0.34	0.21	8.0	5.0	30.0	201	125
	Cross Country #3	3.89	2.42	40.2	25.0	70.0	1,820	1,131
	Cross Country #4	2.14	1.33	24.1	15.0	60.0	998	620
TOTAL MILES							8,451	5,251
Obstacles	6-in. half round	NA		16.1	10.0	0	80 events	
	8-in. half round	NA		16.1	10.0	0	80 events	
	8-in. curb	NA		16.1	10.0	0	80 events	
	Pothole 1	NA		16.1	10.0	0	80 events	
	Frame Twister	NA		8.0	5.0	0	40 events	

TABLE 5. EXAMPLE TEST INCIDENT SUMMARY

Event No.	Equivalent Field Test Distance		Description	Corrective Action
	km	mi		
1	402.3	250.0	Crack found in right rear frame member	Monitored
2	1689.8	1050.0	Left Front Headlight fell out of hood	Repaired
3	3540.5	2200.0	Right front lower ball joint failed	Repaired
4	8046.7	5000.0	Crack found in left front shock tower	Monitored

7. CONCLUDING REMARKS.

The generalized process for simulating on the ATC VDS has been defined for a vehicle system, trailer, or constrained test item. The TOP should serve as a guide for the simulator testing process, but each test item has unique attributes that need to be considered during the data collection and simulation development process. The details not specified in the TOP should be determined with help from the listed references and the application of sound engineering judgement.

APPENDIX A. EXAMPLE TEST PLAN.

FIELD DATA ACQUISITION FOR VEHICLE DURABILITY SIMULATOR TEST.

A.1 OBJECTIVE.

Testing will be conducted to determine the endurance, reliability, and durability characteristics of each vehicle and its subsystems when excited by the U.S. Army Aberdeen Test Center (ATC) Vehicle Durability Simulator (VDS).

A.2 CRITERION AND DATA ANALYSIS.

None provided. Testing will be conducted for baseline purposes.

A.3 TEST PROCEDURES AND DATA REQUIRED.

a. The simulation profiles for the VDS will be developed for the courses specified in the generic mission profile (Table A-1). Data will be taken on all the courses presented in Table A-2. The vehicle will be instrumented with the sensors listed in Table A-3. The data will be recorded at course speed. Runs on each course should be repeated because the statistical nature of RAM data requires a variety of valid inputs on each course to capture a variety of valid responses. For this reason, some courses should be run in both clockwise (CW) and counterclockwise (CCW) directions, for at least 3 laps in each direction run. In addition to the listed courses for the mission profile, data will be collected on the following courses for investigative purposes: 2-Inch washboard (5 mph), Radial Washboard (15 mph), 3-Inch Spaced Bump (15 and 20 mph).

APPENDIX A. EXAMPLE TEST PLAN.

TABLE A-1. GENERIC MISSION PROFILE

TEST COURSE	PER COURSE, %	TOTAL DISTANCE	
		kilometer	mile
Paved	15.0	4,828	3,000
Secondary	35.0	11,265	7,000
Gravel	10.0	3,219	2,000
Belgian Block	10.0	3,219	2,000
Secondary Course	15.0	4,828	3,000
Cross-Country	50.0	16,093	10,000
Cross-Country Course #1	10.0	3,219	2,000
Cross-Country Course #2	10.0	3,219	2,000
Cross-Country Course #3	10.0	3,219	2,000
Cross-Country Course #4	20.0	6,437	4,000
Total	100.0	32,187	20,000

TABLE A-2. PROPOSED COURSE RUN LOG

COURSE	NOMINAL SPEEDS, MPH AVERAGE, (MAX/MIN)	DIRECTION (CW/CCW)	MINIMUM LAPS PER DIRECTION
Cross-Country Course #1	30, (35, 20)	CW/CCW	3
Cross-Country Course #2	30, (35, 20)	CW/CCW	3
Cross-Country Course #3	23, (25, 18)	CW/CCW	3
Cross-Country Course #4	18, (22, 15)	CW/CCW	3
Secondary Course	20, (35/0)	CW/CCW	3
Gravel	30, (35/20)	Either	3
Belgian Block	23 (25/20)	Either	3
2in Washboard	5	Either	3
Radial Washboard	15	Either	3
3in Spaced Bump	15, 20	Either	3

APPENDIX A. EXAMPLE TEST PLAN.

TABLE A-3. VEHICLE INSTRUMENTATION LIST

CHANNE L	CHANNEL DESCRIPTION	UNITS	SENSOR MAKE, MODEL
1	Right Rear Spindle Z	g	Endevco, 7265A**
2	Right Rear Spindle X	g	Endevco, 7265A**
3	Right Rear Spindle Y	g	Endevco, 7265A-HS**
4	Right Rear Frame Z	g	Endevco, 7265A-HS**
5	Left Rear Spindle X	g	Endevco, 7265A**
6	Left Rear Spindle Y	g	Endevco, 7265A-HS**
7	Left Rear Spindle Z	g	Endevco, 7265A**
8	Left Rear Frame Z	g	Endevco, 7265A-HS**
9	Right Front Spindle X	g	Endevco, 7265A**
10	Right Front Spindle Y	g	Endevco, 7265A-HS**
11	Right Front Spindle Z	g	Endevco, 7265A**
12	Right Front Frame Z	g	Endevco, 7265A-HS**
13	Left Front Spindle X	g	Endevco, 7265A**
14	Left Front Spindle Y	g	Endevco, 7265A-HS**
15	Left Front Spindle Z	g	Endevco, 7265A**
16	Left Front Frame Z	g	Endevco, 7265A**
17	Right Front Wheel Displacement	in	Celesco, CLP 250**
18	Left Front Wheel Displacement	in	Celesco, CLP 250**
19	Right Rear Wheel Displacement	in	Celesco, CLP 250**
20	Left Rear Wheel Displacement	in	Celesco, CLP 250**
21	Right Front Shock Temp	°C	NA
22	Left Front Shock Temp	°C	NA
23	Right Rear Shock Temp	°C	NA
24	Left Rear Shock Temp	°C	NA
25	Right Front Tie Rod	lbf	Vishay, CEA-06-062WT**
26	Left Front Tie Rod	lbf	Vishay, CEA-06-062WT**
27	Left Rear Tie Rod	lbf	Vishay, CEA-06-062WT**
28	Right Rear Tie Rod	lbf	Vishay, CEA-06-062WT**
29	Driver Seatpad X	g	Endevco, 7265A-HS**
30	Driver Seatpad Y	g	Endevco, 7265A-HS**
31	Driver Seatpad Z	g	Endevco, 7265A-HS**
32	Driver Floor Z	g	Endevco, 7265A-HS**
33	Brake Pedal Effort	lbf	GSA Incorporated, 114350**
34	Ambient Air Temperature	°C	NA
35	Left Rear Lower Arm Strain	με	Vishay, CEA-06-125UR**
36	Left Front Lower Arm Strain	με	Vishay, CEA-06-125UR**

APPENDIX A. EXAMPLE TEST PLAN.

TABLE A-3. CONTINUED

CHANNEL	CHANNEL DESCRIPTION	UNITS	SENSOR MAKE, MODEL
37	Motion Pack Acceleration X Direction	g	Memsic, VG440**
38	Motion Pack Acceleration Y Direction	g	Memsic, VG440**
39	Motion Pack Acceleration Z Direction	g	Memsic, VG440**
40	Motion Pack Pitch Rate	deg/s	Memsic, VG440**
41	Motion Pack Roll Rate	deg/s	Memsic, VG440**
42	Motion Pack Yaw Rate	deg/s	Memsic, VG440**
43	Motion Pack Pitch Angle	deg	Memsic, VG440**
44	Motion Pack Roll Angle	deg	Memsic, VG440**
45	Motion Pack Yaw Angle	deg	Memsic, VG440**
46	Left Front Frame 0	$\mu\epsilon$	Vishay, CEA-06-125UR**
47	Left Front Frame 45	$\mu\epsilon$	Vishay, CEA-06-125UR**
48	Left Front Frame 90	$\mu\epsilon$	Vishay, CEA-06-125UR**
49	Left Front Spindle Tie Rod Accelerometer	g	Endevco, 7265A**
50	Right Front Spindle Tie Rod Accelerometer	g	Endevco, 7265A**
51	Steering Draglink Displacement	in	Celesco, CLP 250**
52	Steering Wheel Angle	deg	Sensor Development, 10207**
53	Steering Wheel Effort	ft-lbf	Sensor Development, 10207**
54	Left Front X Direction Force	lbf	MTS, Swift 40**
55	Left Front Y Direction Force	lbf	MTS, Swift 40**
56	Left Front Z Direction Force	lbf	MTS, Swift 40**
57	Left Front Moment About X Axis	ft-lbf	MTS, Swift 40**
58	Left Front Moment About Y Axis	ft-lbf	MTS, Swift 40**
59	Left Front Moment About Z Axis	ft-lbf	MTS, Swift 40**
60	Left Front Angle	deg	MTS, Swift 40**
61	Non-Contact Vehicle Speed	mph	Corrsys Datron, Microstar**
62	Right Front X Direction Force	lbf	MTS, Swift 40**
63	Right Front Y Direction Force	lbf	MTS, Swift 40**
64	Right Front Z Direction Force	lbf	MTS, Swift 40**
65	Right Front Moment About X Axis	ft-lbf	MTS, Swift 40**
66	Right Front Moment About Y Axis	ft-lbf	MTS, Swift 40**
67	Right Front Moment About Z Axis	ft-lbf	MTS, Swift 40**
68	Right Front Angle	deg	MTS, Swift 40**
69	Left Rear X Direction Force	lbf	MTS, Swift 40**
70	Left Rear Y Direction Force	lbf	MTS, Swift 40**
71	Left Rear Z Direction Force	lbf	MTS, Swift 40**
72	Left Rear Moment About X Axis	ft-lbf	MTS, Swift 40**

APPENDIX A. EXAMPLE TEST PLAN.

TABLE A-3. CONTINUED

CHANNEL	CHANNEL DESCRIPTION	UNITS	SENSOR MAKE, MODEL
73	Left Rear Moment About Y Axis	ft-lbf	MTS, Swift 40**
74	Left Rear Moment About Z Axis	ft-lbf	MTS, Swift 40**
75	Left Rear Wheel Rotational Angle	deg	MTS, Swift 40**
76	Right Rear X Direction Force	lbf	MTS, Swift 40**
77	Right Rear Y Direction Force	lbf	MTS, Swift 40**
78	Right Rear Z Direction Force	lbf	MTS, Swift 40**
79	Right Rear Moment About X Axis	ft-lbf	MTS, Swift 40**
80	Right Rear Moment About Y Axis	ft-lbf	MTS, Swift 40**
81	Right Rear Moment About Z Axis	ft-lbf	MTS, Swift 40**
82	Right Rear Wheel Rotational Angle	deg	MTS, Swift 40**

** The particular identification of a sensor make or model should not be considered an endorsement of a product or company but rather should only be used as a reference for the range and sensitivity expected for this particular application.

b. After field testing, the vehicle will then be prepped and installed on the simulator to create the corresponding drive profiles. During reliability testing on the VDS, vehicle failure rates and mileage will be recorded. Ideally these failure rates and mileage would be compared with previous in-field RAM testing on the same endurance courses. Unfortunately a comparison with historical RAM failures rates and mileage will not necessarily show the same results. This is because of the great uncertainties associated with the previous RAM testing that had occurred with this vehicle.

c. The particular ordering of the channels is not relevant, as long as the ordering remains consistent throughout testing. Changes in instrumentation during field testing should be cautioned against. If instrumentation changes do occur, a significant effort should be made to ensure that the new transducer is very similar to the original both in magnitude response and phase response across a broad range of the relevant frequency spectrum. The acquisition sample rate should be at least 512 Hz with an anti-aliasing filter with a cut-off frequency of 200 Hz.

d. The force values from the tierod locations in channel 25 through 28 are to be determined by first strain gauging the tie rods to measure axial strain and then determining the tierod sensitivity by applying an axially compressive load with a calibrated load-cell. Many of the channels listed in Table A-3 will not be used in the control loop of the VDS, but will only be used for informational purposes to guide the data analysis. These include but are not limited to channels 21 through 24, 29 through 34, 43 through 45, 52 and 53, and 61. The vehicle should also be instrumented with a Global Positioning System receiver, which is coupled with the acquisition of the other transducer data.

APPENDIX A. EXAMPLE TEST PLAN.

e. At the beginning and end of a data acquisition run the vehicle should be stationary for at least 10 seconds. During this stationary period the vehicle should be parked on level ground with the transmission in neutral and driver's foot off the brake. The vehicle should be located at the same location for the beginning and end of the data run.

f. Adherence to a global coordinate system is recommended. It is recommend to follow one of the vehicle coordinate systems defined in Society of Engineers (SAE) Recommended Practice J670e⁹. Typically the z-axis up coordinate system is used for VDS tests.

APPENDIX B. RAINFLOW COUNTING REVIEW.

The outline in this appendix presents the process for rainflow counting of a discrete time history signal. The process steps are similar to those used in the MTS RPC Pro software when calculating the damage time history and fatigue cycles.

B.1. The local extrema (minima and maxima) are identified, forming a peak-valley time history. Reference plot (a) in Figure B-1. Assume the time history is to be repeated so that any given peak can be considered the beginning and end.

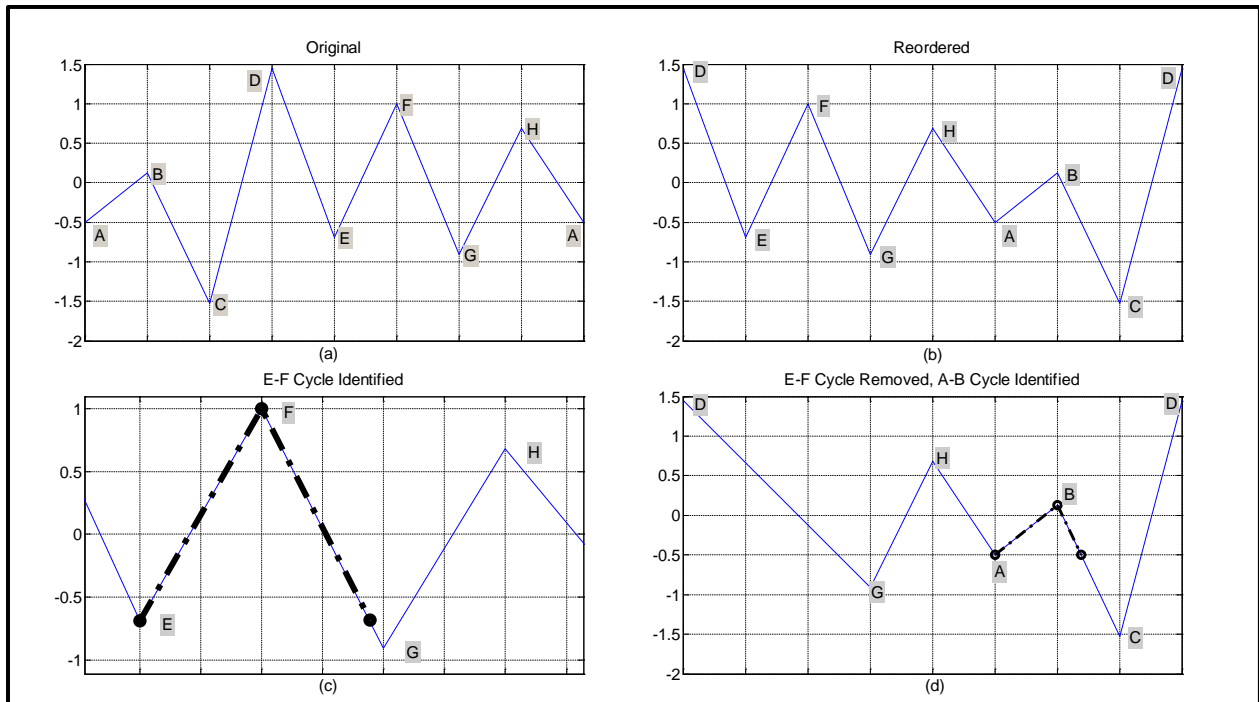

Figure B-1. Example steps for identifying a cycle in rainflow cycle counting.

B.2. For convenience, reorder the time history so the largest absolute value is the first point, with all prior points being appended at the end as if the time history was a repeated loop. Reference plot (b) in Figure B-1.

B.3. Proceeding from left to right, identify a cycle based on the following definitions:

- a. An upturned cycle is identified as the portion of the time history which changes from local maxima to local minima back to local maxima when the later local maxima exceeds (or equals) the initial local maxima. (A cycle is not present where a maxima is followed by a maxima which does not rise above the initial local maxima.)

APPENDIX B. RAINFLOW COUNTING REVIEW.

b. A downturned cycle is identified when the time history changes from a local minima to local maxima to local minima with the later local minima exceeding (or equaling) the initial local minima. (A cycle is not present where a minima is followed by a minima which does not rise above the initial local minima.)

c. In plot (c) of Figure B-1, E-F is identified as a downturned cycle.

B.4. Record the range and mean of the identified cycle and remove the extrema from the peak-valley time history, as shown in plot (d) of Figure B-1.

B.5. Repeat steps B.3 and B.4 until all cycles have been identified. Under this algorithm, neither the changes from G-H or H-A qualify yet as cycles, because the subsequent extrema do not exceed their values. But A-B is identified as another downturn cycle because C exceeds A. When A-B is removed, G-H is next cycle to be identified. Removing G-H leaves D-C-D as the final cycle.

APPENDIX C. VEHICLE DURABILITY SIMULATOR SPINDLE MATRIX CHANNEL CONFIGURATION.

a. The configuration of the control channels is an important aspect of operating the VDS system. It is important to understand how the control channels are configured in order to safely and effectively operate the rig. It is typical for a drive channel configuration to be dependent upon the test vehicle being mounted to the rig. The typical control channel list and mode setting are defined in Table C-1 for a four wheel vehicle mounted to the VDS. The configuration mode is known as spindle matrix and is the most common setup used on the VDS and is the default configuration for most tests.

TABLE C-1. CONTROL CHANNELS AND MODE FOR SPINDLE MATRIX CONFIGURATION

CHANNEL	CONTROL MODE
Left Longitudinal Compression	Force
Front Lateral Compression	Force
Left Front Vertical	Displacement
Front Camber	Moment
Left Front Brake	Angle
Front Steer	Angle
Right Longitudinal Compression	Force
Lateral Translation	Displacement
Right Front Vertical	Displacement
Front Rack	Moment
Right Front Brake	Angle
Front Toe	Moment
Longitudinal Translation	Displacement
Rear Lateral Compression	Force
Left Rear Vertical	Displacement
Rear Camber	Moment
Left Rear Brake	Angle
Rear Steer	Moment
Shear	Force
Yaw	Angle
Right Rear Vertical	Displacement
Rear Rack	Moment
Right Rear Brake	Angle
Rear Toe	Moment

APPENDIX C. VEHICLE DURABILITY SIMULATOR SPINDLE MATRIX CHANNEL CONFIGURATION.

b. All the control channels except for vertical and brake are dependent upon multiple actuators and rig sensors in order to close the feedback loop. For example, the Yaw control channel influences 16 actuator valve signals and is dependent upon 20 separate rig displacement measurements. Multiple control channels can be dependent upon the same rig measurements and each influence the behavior of the referenced actuator. An outline of the signal coupling is provide below (Equations C-1 through C-24) for reference in the typical configuration. An overview of the polarity and actuator orientation for each coupled control channel is provide in Figures C-1 through C-12.

$$\text{"Left Long Comp Force"} = 0.5 * (\text{"LF Spindle Fx"} - \text{"LR Spindle Fx"}) \quad (\text{Equation C-1})$$

$$\text{"Front Lat Comp Force"} = 0.5 * (\text{"LF Spindle Fy"} + \text{"RF Spindle Fy"}) \quad (\text{Equation C-2})$$

$$\text{"LF Vert Displacement"} = \text{"LF Spindle Dz"} \quad (\text{Equation C-3})$$

$$\text{"Front Camber Moment"} = 0.5 * (\text{"LF Spindle Mx"} + \text{"RF Spindle Mx"}) \quad (\text{Equation C-4})$$

$$\text{"LF BrakeAngle"} = \text{"LF Spindle @y"} \quad (\text{Equation C-5})$$

$$\text{"Front SteerAngle"} = 0.5 * (\text{"LF Spindle @z"} + \text{"RF Spindle @z"}) \quad (\text{Equation C-6})$$

$$\text{"Right Long CompForce"} = 0.5 * (\text{"RR Spindle Fx"} - \text{"RF Spindle Fx"}) \quad (\text{Equation C-7})$$

$$\text{"Lat Trans Displacement"} = 0.25 * (\text{"LF Spindle Dy"} - \text{"RF Spindle Dy"} + \text{"LR Spindle Dy"} - \text{"RR Spindle Dy"}) \quad (\text{Equation C-8})$$

$$\text{"RF Vert Displacement"} = \text{"RF Spindle Dz"} \quad (\text{Equation C-9})$$

$$\text{"Front Rack Moment"} = (\text{"RF Spindle Mx"} - \text{"LF Spindle Mx"}) \quad (\text{Equation C-10})$$

$$\text{"RF BrakeAngle"} = - \text{"RF Spindle @y"} \quad (\text{Equation C-11})$$

$$\text{"Front Toe Moment"} = 0.5 * (\text{"RF Spindle Mz"} - \text{"LF Spindle Mz"}) \quad (\text{Equation C-12})$$

$$\text{"Long Trans Displacement"} = 0.25 * (\text{"LF Spindle Dx"} - \text{"RF Spindle Dx"} + \text{"LR Spindle Dx"} - \text{"RR Spindle Dx"}) \quad (\text{Equation C-13})$$

$$\text{"Rear Lat CompForce"} = 0.5 * (\text{"RR Spindle Fy"} + \text{"LR Spindle Fy"}) \quad (\text{Equation C-14})$$

$$\text{"LR Vert Displacement"} = \text{"LR Spindle Dz"} \quad (\text{Equation C-15})$$

$$\text{"Rear Camber Moment"} = 0.5 * (\text{"LR Spindle Mx"} + \text{"RR Spindle Mx"}) \quad (\text{Equation C-16})$$

APPENDIX C. VEHICLE DURABILITY SIMULATOR SPINDLE MATRIX CHANNEL
CONFIGURATION.

$$\text{"LR BrakeAngle"} = \text{"LR Spindle @y"} \quad (\text{Equation C-17})$$

$$\text{"Rear Steer Moment"} = (\text{"LR Spindle Mz"} + \text{"RR Spindle Mz"}) \quad (\text{Equation C-18})$$

$$\begin{aligned} \text{"ShearForce"} = 0.5 * (\text{"LF Spindle Fx"} + \text{"RF Spindle Fx"} + \text{"LR Spindle Fx"} + \\ \text{"RR Spindle Fx"} + \text{"LF Spindle Fy"} - \text{"RF Spindle Fy"} - \text{"LR Spindle Fy"} + \\ \text{"RR Spindle Fy"}) \quad (\text{Equation C-19}) \end{aligned}$$

$$\begin{aligned} \text{"YawAngle"} = 14.32 * ((\text{"LF Spindle Dx"} + \text{"RF Spindle Dx"} + \text{"LR Spindle Dx"} + \text{"RR} \\ \text{Spindle Dx"}) / \text{"Track Width"} + (\text{"RF Spindle Dy"} - \text{"LF Spindle Dy"} - \text{"RR Spindle Dy"} + \\ \text{"LRSpindle Dy"}) / \text{"Wheel Base"}) \quad (\text{Equation C-20}) \end{aligned}$$

$$\text{"RR Vert Displacement"} = \text{"RR Spindle Dz"} \quad (\text{Equation C-21})$$

$$\text{"Rear Rack Moment"} = (\text{"RR Spindle Mx"} - \text{"LR Spindle Mx"}) \quad (\text{Equation C-22})$$

$$\text{"RR BrakeAngle"} = -\text{"RR Spindle @y"} \quad (\text{Equation C-23})$$

$$\text{"Rear Toe Moment"} = 0.5 * (\text{"RR Spindle Mz"} - \text{"LR Spindle Mz"}) \quad (\text{Equation C-24})$$

where:

LF = Left Front

RF = Right Front

LR = Left Rear

RR = Right Rear

@y = Angle about the y axis of the spindle head

@z = Angle about the z axis of the spindle head

Dx = the displacement in the x axis direction at the spindle head

Dy = the displacement in the y axis direction at the spindle head

Dz = the displacement in the z axis direction at the spindle head

Mx = the moment about the x axis of the spindle head

Mz = the moment about the z axis of the spindle head

Fx = the force in the x axis direction at the spindle head

Fy = the force in the y axis direction at the spindle head

Fz = the force in the z axis direction at the spindle head

APPENDIX C. VEHICLE DURABILITY SIMULATOR SPINDLE MATRIX CHANNEL CONFIGURATION.

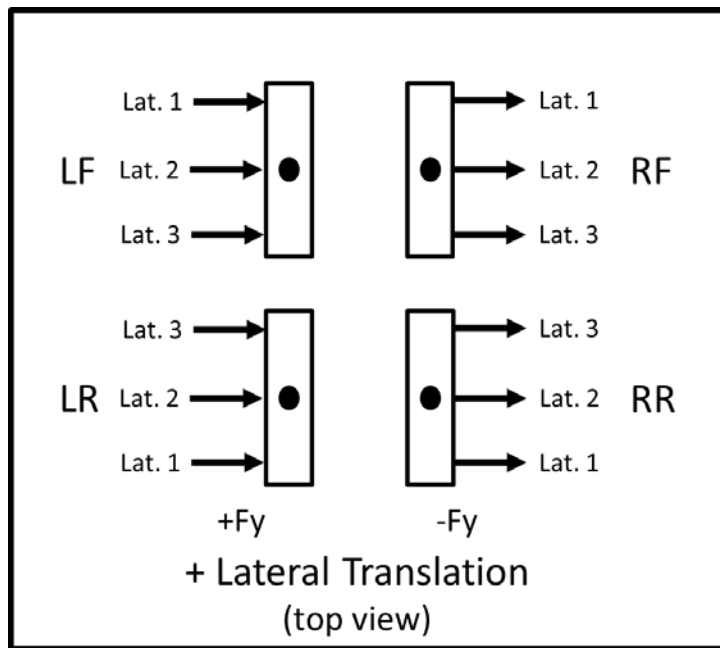

Figure C-1. Lateral translation control channel actuator coupling and polarity.

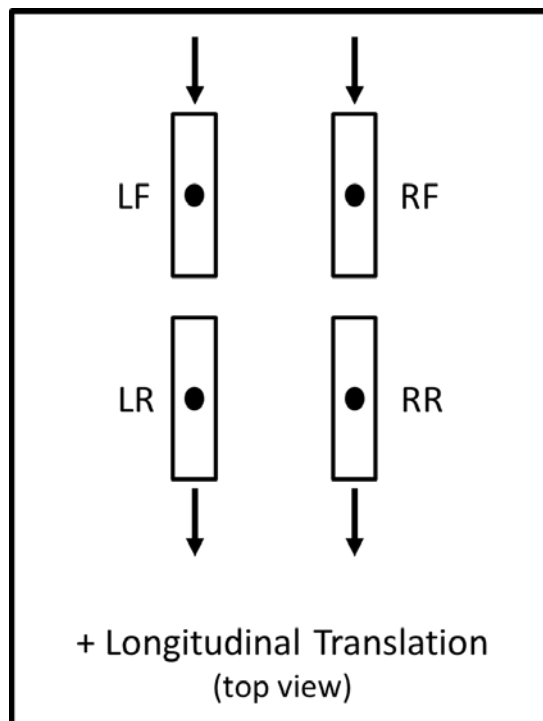

Figure C-2. Longitudinal translation control channel actuator coupling and polarity.

APPENDIX C. VEHICLE DURABILITY SIMULATOR SPINDLE MATRIX CHANNEL CONFIGURATION.

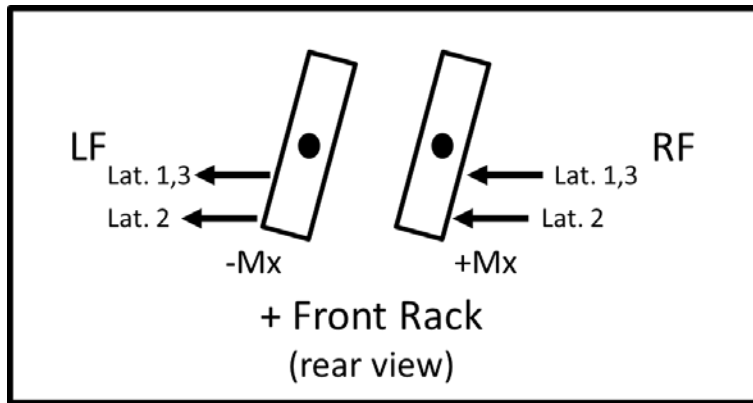

Figure C-3. Front rack control channel actuator coupling and polarity.

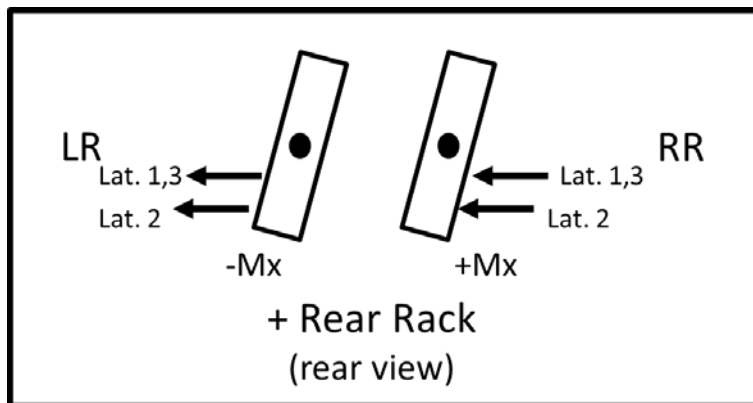

Figure C-4. Rear rack control channel actuator coupling and polarity.

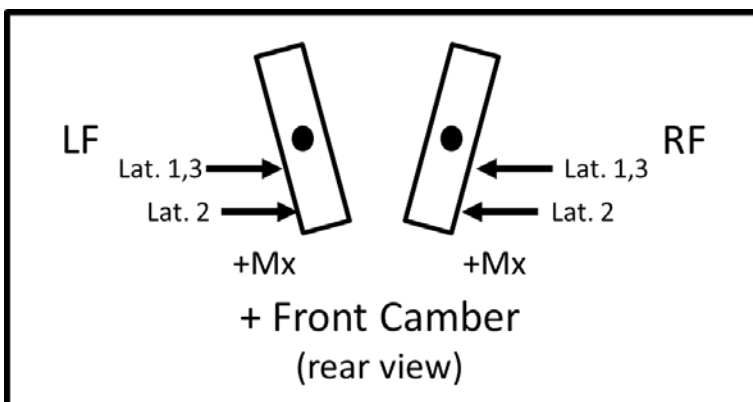

Figure C-5. Front camber control channel actuator coupling and polarity.

APPENDIX C. VEHICLE DURABILITY SIMULATOR SPINDLE MATRIX CHANNEL CONFIGURATION.

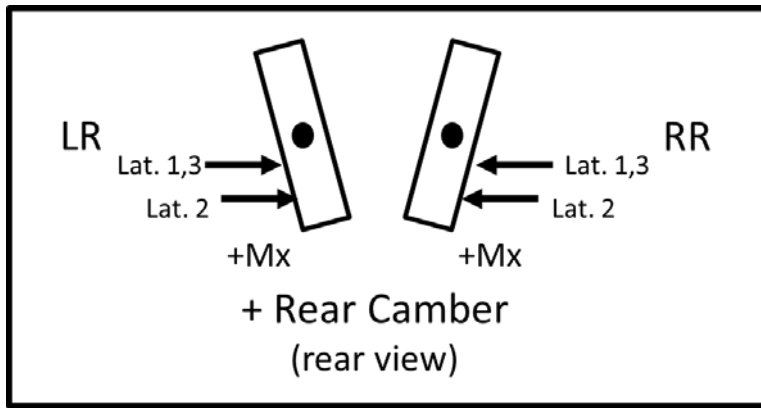

Figure C-6. Rear camber control channel actuator coupling and polarity.

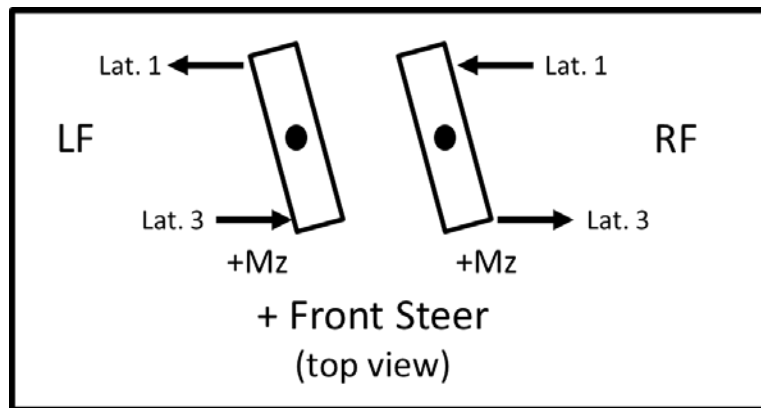

Figure C-7. Front steer control channel actuator coupling and polarity.

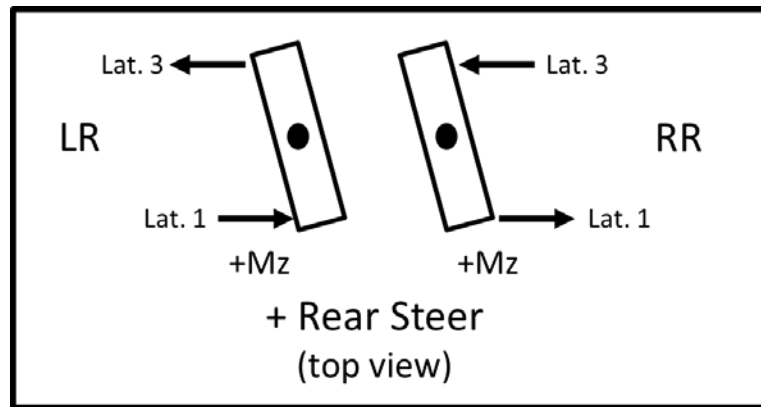

Figure C-8. Rear steer control channel actuator coupling and polarity.

APPENDIX C. VEHICLE DURABILITY SIMULATOR SPINDLE MATRIX CHANNEL CONFIGURATION.

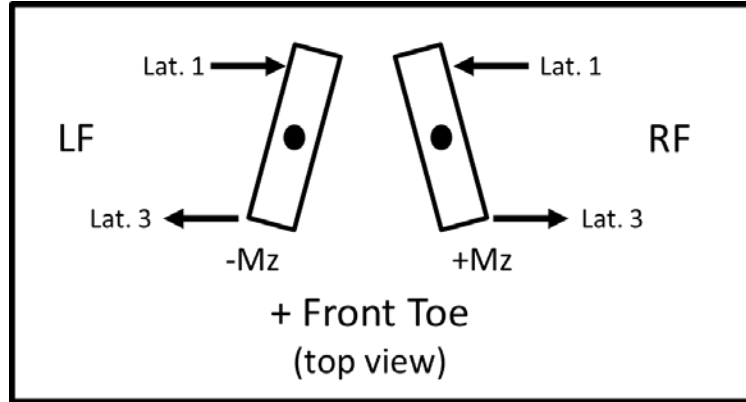

Figure C-9. Front toe control channel actuator coupling and polarity.

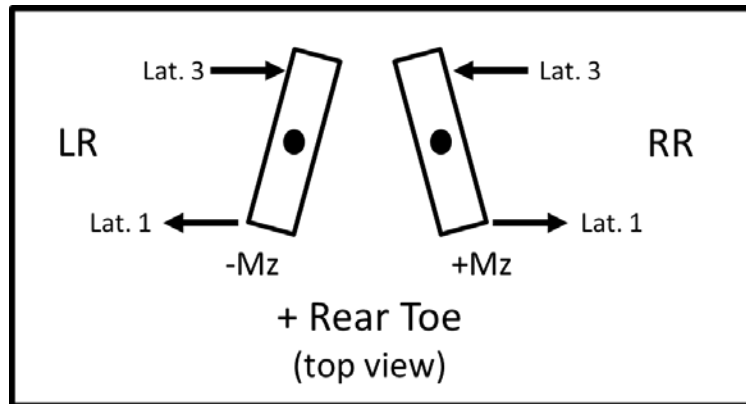

Figure C-10. Rear toe control channel actuator coupling and polarity.

APPENDIX C. VEHICLE DURABILITY SIMULATOR SPINDLE MATRIX CHANNEL CONFIGURATION.

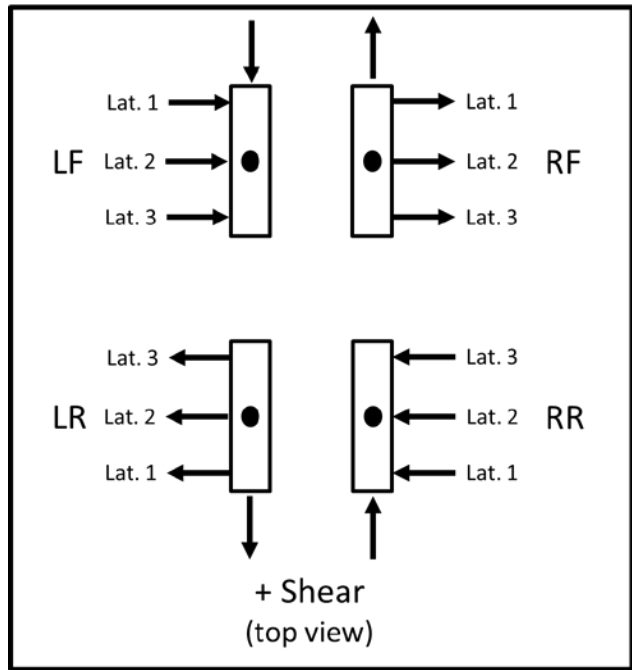

Figure C-11. Shear control channel actuator coupling and polarity.

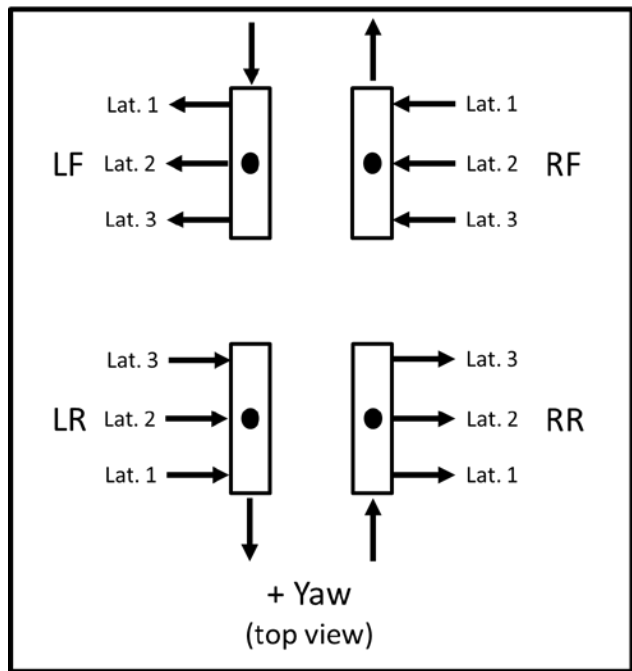

Figure C-12. Rear toe control channel actuator coupling and polarity.

APPENDIX D. REMOTE PARAMETER AND CONTROL MODE DISCUSSION.

a. A control channel is not necessarily limited to controlling a single actuator in the default spindle matrix control mode. A control channel can be dependent upon multiple actuators and rig sensors in order to achieve the desired type of control. For example, the Yaw control channel influences 16 actuator valve signals and is dependent upon 20 separate rig displacement measurements. Multiple control channels can be dependent upon the same rig measurements and each influence the behavior of the referenced actuator.

b. It is important to understand how the control channels are configured in order to safely and effectively operate the rig. It is typical for a drive channel configuration to be dependent upon the test item being mounted to the rig. It is best practice to rely on pre-existing configurations with known properties. Alterations to the configuration should be explored and understood before being fully implemented because the changes may have unintended effects on the test item simulation.

c. As mentioned in the description of the VDS, each support post is controlled with six actuators. Generally the test is not setup for controlling the individual actuators directly. For instance, on a four wheel vehicle configuration, the “Front Lateral Translation” force input control channel is a combination of the front left and front right lateral force channels. For a four post configuration the 24 actuator control channels will be mapped in different ways to result in 24 input control channels ($N_d = 24$). Care must be taken as to whether the input control channel is setup to control the displacement or force applied through that channel. An improper setup could cause damage to the test item by trying to achieve an unrealizable displacement.

d. The determination for each control channel as to the control mode should be made based on the constraint of the system under test. Typically free body translations are in displacement control. If the chassis lateral control channel were used in force control the system would potentially command a slow displacement of the system until the actuators run out of travel. Therefore, any command channels that are not internally reacted by the system under test should be placed in displacement control mode. The internally reacted channels such as camber moment and rack moments should be placed in force control mode so that the machine does not damage the system under test by forcing it to an unrealizable displacement or angle.

d. Each control channel is managed through a PID control loop. Because the test item plays such an important role in the overall system response, the proper PID parameters need to be established for every new test item. These parameters can be established by evaluating the response to various inputs, such as square waves and pink noise (1/frequency (f) and $1/f^2$ spectral content).

e. The method used to create the drive time histories will depend on the intention of the test. If the intention of testing is to characterize the test item with any plausible realization of a spectral waveform, then time histories are created using a method of time domain randomization. The randomization assumptions are made about the distribution of frequency domain phase values (generally Gaussian). If the intention of the test is time waveform replication, or something similar, standard RPC methods would suffice.

APPENDIX D. REMOTE PARAMETER AND CONTROL MODE DISCUSSION.

f. The RPC method uses a multiple step process to first estimate the full system FRF through orthogonal random content, and then use the FRF estimate while testing. The FRF is an array of spectral content having N_c rows and N_d columns, with the element in the i^{th} row and j^{th} column representing the spectral response of the i^{th} sensor to the j^{th} input control channel. Prior to testing, the drive estimate, for the actual time histories that will be used during testing, is derived from the FRF estimate. This drive estimate is then improved through an iterative process whereby the response error from the original drive estimate is used to improve the drive estimate for the next iteration. This iterative process is repeated, with reasonably small increment changes, until the error between achieved and desired response is small. Typically 5 to 20 incremental steps are needed to create sufficiently small errors.

APPENDIX E. GLOSSARY.

Term	Definition
Outer Control Loop	Refers to the outer proportional-integral-derivate (PID) control loop in a cascade controls setup. In a cascade controls configuration there are two PID control loops. The advantage of a two PID control loops is better dynamic performance. The outer control loop term for the VDS refers to the three-stage control actuators. On the VDS only the vertical, longitudinal, and camber actuators have both an outer and inner control loop.
Inner Control Loop	Refers to the inner or first PID control loop in a cascade control system setup. The inner loop PID for the VDS refers to the pilot controlled servo valve on three stage actuator setup.
Three-Stage Servo Valve	In servo valves a stage provides hydraulic force amplification. Typically a two-stage servo valve uses an electrical signal to regulate hydraulic fluid flow to an actuator. A three-stage servo has an additional spool valve between the first spool valve and the actuator. The first spool valve provides a spool change in pressure to the second spool valve. Three-stage valves are typically used when more hydraulic fluid flow is necessary than can be provided by a two stage setup. The vertical, longitudinal, and camber actuators have a three stage servo valve setup.
Multiple Degree of Freedom (MDOF)	Refers to motion defined by test item movement along or about more than one axis and whose description require two or more coordinates to completely define the position of the item at any instant. The position and orientation of a rigid body moving space in space is defined by three translational and three rotational components, which equals six degrees of freedom.

(This page is intentionally blank.)

APPENDIX F. ABBREVIATIONS.

ASD	auto spectral density
ASTM	American Society for Testing and Materials
ATC	U.S. Army Aberdeen Test Center
CAD	computer-aided design
CCW	counterclockwise
CTA	Churchville Test Area
CW	clockwise
db	decibel
DOF	degree-of-freedom
DTH	damage time history
FDSC	failure definition scoring criteria
FEA	finite element analysis
FFT	Fast Fourier Transform
FRF	frequency response function
ft-lbf	foot-pound force
<i>g</i>	acceleration of gravity
HMMWV	High Mobility Multipurpose Wheeled Vehicle
Hz	Hertz
IEST	Institute of Environmental Sciences and Technology
in.	inch
km	kilometer
kN	kilonewton
kNm	kilonewton meter
lb	pound
lbf	pounds force
LCEP	life cycle environment profile
MDOF	multiple degree-of-freedom
MIL-STD	Military Standard
mm	millimeter
mph	miles per hour
MTA	Munson Test Area
OMS/MP	Operational Mode Summary

APPENDIX F. ABBREVIATIONS.

PID	proportional-integral-derivative
PSD	power spectral density
PTA	Perryman Test Area
RAM	reliability, availability, and maintainability
RDE	relative damage estimate
RMS	root mean square
RPC	remote parameter control
SAE	Society of Automotive Engineers
SWT	Smith-Watson-Topper
TARDEC	U.S Army Tank Automotive Research, Development and Engineering Center
TOP	Test Operations Procedure
TWR	time waveform replication
VDS	Vehicle Durability Simulator
VV&A	Verification, Validation, and Accreditation

APPENDIX G. REFERENCES.

1. MIL-STD-810G Change Notice 1, Department of Defense Test Method Standard: Environmental Engineering Considerations and Laboratory Tests, 15 April 2014.
2. Handbook for Dynamic Data Acquisition and Analysis, IEST-RP-DTE012.2, Institute of Environmental Sciences and Technology, Arlington Place One, 2340 S. Arlington Heights Road, Suite 100, Arlington Heights, IL 60005-4516.
3. TOP 02-2-505 Inspection and Preliminary Operation of Vehicles, 4 February 1987.
4. Multi-Shaker Test and Control: Design, Test, and Evaluation Division Recommended Practice 022.1, IEST-RP-DTE022.1, October 2014.
5. Welch, P.D., "The Use of Fast Fourier Transform for the Estimation of Power Spectra: A Method Base on Time Averaging Over Short, Modified Periodograms", Institute of Electrical and Electronics Engineers Transactions on Audio and Electroacoustics, Volume AU-15, Number 2 / June 1967.
6. ASTM E1049-85(2011)e1, Standard practices for cycle counting in fatigue analysis, ASTM International, west Conshohocken, PA, 2011, www.astm.org.
7. Brudnak, M., Walsh, J., Baseski, I., and LaRose, B., "Durability Test Time Reduction Methods," SAE Int. J. Commer. Veh. 10(1):113-121, 2017, doi:10.4271/2017-01-0258.
8. TOP 01-2-602, Laboratory Vibration Test Schedule Development for Multi-Exciter Applications, 17 August 2011.
9. SAE Recommended Practice J670e, Vehicle Dynamics Terminology, January 2008.

For information only (related publications).

- a. Wirsching, Paez, and Ortiz, Random Vibrations, Theory and Practice, Wiley 1995.
- b. GMW15269, Structural Durability Pseudo-Fatigue Damage Analysis, GM Worldwide Engineering Standards, January 2014.
- c. Prakash, S. "A Method of Accelerating Durability Tests by Pseudo Damage Editing," Society of Automotive Engineers Technical Paper 2013-26-0138, January 2013.
- d. TOP 02-2-506A, Wheeled and Tracked Vehicle Endurance Testing, 2 October 2014.
- e. TOP 01-2-502, Durability, 19 December 1984.

(This page is intentionally blank.)

APPENDIX H. APPROVAL AUTHORITY.

CSTE-TM

20 November 2017

MEMORANDUM FOR

Commanders, All Test Centers
Technical Directors, All Test Centers
Directors, U.S. Army Evaluation Center
Commander, U.S. Army Operational Test Command

SUBJECT: Test Operations Procedure (TOP) 01-2-515 Reliability Testing Using the Vehicle Durability Simulator, Approved for Publication

1. TOP 01-2-515 Reliability Testing Using the Vehicle Durability Simulator, has been reviewed by the U.S. Army Test and Evaluation Command (ATEC) Test Centers, the U.S. Army Operational Test Command, and the U.S. Army Evaluation Center. All comments received during the formal coordination period have been adjudicated by the preparing agency. The scope of the document is as follows:

This TOP describes methods for performing reliability testing using a Vehicle Durability Simulator (VDS) for wheeled vehicles and trailers. The evaluated subsystems for a reliability test on the VDS include structural members, suspension components, armor mounting, and any other chassis mounted subsystems. The VDS does not test reliability of the vehicle powertrain.

2. This document is approved for publication and will be posted to the Reference Library of the ATEC Vision Digital Library System (VDLS). The VDLS website can be accessed at <https://vdl.s.atc.army.mil/>.

3. Comments, suggestions, or questions on this document should be addressed to U.S. Army Test and Evaluation Command (CSTE-TM), 2202 Aberdeen Boulevard-Third Floor, Aberdeen Proving Ground, MD 21005-5001; or e-mailed to usarmy.apg.atec.mbx.atec-standards@mail.mil.

BRACAMONTE.LA
ZARO.F.123173344
9



LAZARO F. BRACAMONTE
Associate Director, Test Management Directorate (G9)

FOR

RAYMOND G. FONTAINE
Director, Test Management Directorate (G9)

(This page is intentionally blank.)

Forward comments, recommended changes, or any pertinent data which may be of use in improving this publication to the following address: Policy and Standardization Division (CSTE-TM), U.S. Army Test and Evaluation Command, 2202 Aberdeen Boulevard, Aberdeen Proving Ground, Maryland 21005-5001. Technical information may be obtained from the preparing activity: Automotive Directorate (TEDT-AT-AD), U.S. Army Aberdeen Test Center, 400 Colleran Road, Aberdeen Proving Ground, Maryland 21005-5059. Additional copies can be requested through the following website: <http://www.atec.army.mil/publications/topsindex.aspx>, or through the Defense Technical Information Center, 8725 John J. Kingman Rd., STE 0944, Fort Belvoir, VA 22060-6218. This document is identified by the accession number (AD No.) printed on the first page.