

UNCLASSIFIED

Registration No.

29840



**TARDEC Fixed Heel Point (FHP): Driver
CAD Accommodation Model
Verification Report**

Frank J. Huston II and Gale L. Zielinski

US Army TARDEC, Warren, MI

**UNCLASSIFIED: Distribution Statement A
Approved for Public Release**

Disclaimer: Reference herein to any specific commercial company, product, process, or service by trade name, trademark, manufacturer, or otherwise, does not necessarily constitute or imply its endorsement, recommendation, or favoring by the United States Government or the Department of the Army (DoA). The opinions of the authors expressed herein do not necessarily state or reflect those of the United States Government or the DoA, and shall not be used for advertising or product endorsement purposes.

9 November 2017

U.S. Army Tank Automotive Research,
Development, and Engineering Center
Detroit Arsenal
Warren, Michigan 48397-5000

UNCLASSIFIED

TARDEC Fixed Heel Point (FHP): Driver CAD Accommodation Model Verification Report
 UNCLASSIFIED: Distribution Statement A. Approve for public release; distribution is unlimited.

REPORT DOCUMENTATION PAGE			<i>Form Approved</i> <i>OMB No. 0704-0188</i>		
Public reporting burden for this collection of information is estimated to average 1 hour per response, including the time for reviewing instructions, searching existing data sources, gathering and maintaining the data needed, and completing and reviewing this collection of information. Send comments regarding this burden estimate or any other aspect of this collection of information, including suggestions for reducing this burden to Department of Defense, Washington Headquarters Services, Directorate for Information Operations and Reports (0704-0188), 1215 Jefferson Davis Highway, Suite 1204, Arlington, VA 22202-4302. Respondents should be aware that notwithstanding any other provision of law, no person shall be subject to any penalty for failing to comply with a collection of information if it does not display a currently valid OMB control number. PLEASE DO NOT RETURN YOUR FORM TO THE ABOVE ADDRESS.					
1. REPORT DATE 03/07.2014 9 Nov 2017		2. REPORT TYPE Technical		3. DATES COVERED (From - To) Jan 2014 - Aug 2017	
4. TITLE AND SUBTITLE TARDEC Fixed Heel Point (FHP): Driver CAD Accommodation Model Verification Report			5a. CONTRACT NUMBER N/A		
			5b. GRANT NUMBER N/A		
			5c. PROGRAM ELEMENT NUMBER N/A		
6. AUTHOR(S) Frank J. Huston II and Gale L. Zielinski			5d. PROJECT NUMBER N/A		
			5e. TASK NUMBER N/A		
			5f. WORK UNIT NUMBER N/A		
7. PERFORMING ORGANIZATION NAME(S) AND ADDRESS(ES) AND ADDRESS(ES) RDECOM-TARDEC-ACT Attn: RDTA-SIE-EA-ADCON-TIC MS 207 6501 E. 11 Mile Road, Warren, MI 48397-5000			8. PERFORMING ORGANIZATION REPORT NUMBER N/A		
9. SPONSORING / MONITORING AGENCY NAME(S) AND ADDRESS(ES) N/A			10. SPONSOR/MONITOR'S ACRONYM(S) N/A		
			11. SPONSOR/MONITOR'S REPORT NUMBER(S) N/A		
12. DISTRIBUTION / AVAILABILITY STATEMENT UNCLASSIFIED: Distribution Statement A. Approved for Public Release, Unlimited Distribution					
13. SUPPLEMENTARY NOTES N/A					
14. ABSTRACT Easy-to-use Computer-Aided Design (CAD) tools, known as accommodation models, are needed by the ground vehicle designers when developing the interior workspace for the occupant. The TARDEC Fixed Heel Point (FHP): Driver CAD Accommodation Model described in this verification report is applicable to truck-like ground vehicles and may also be used in workstations that require the crew to interact with vehicle controls and non-driving displays using hands, horizontal directed vision, and adjustable seats. The FHP: Driver CAD model is a parametric model that is intended to provide the composite boundaries representing the body of the defined target design population, including posture prediction. Clearances between the occupant and surrounding interior vehicle surfaces have been added per MIL-STD-1472G. Direct vision zones and ground intercept have been added based on MIL-STD-1472G and SAE Recommended Practice J1050. The intention of verification is to build confidence in the CAD accommodation model. Model verification included ten test scenarios for comparing the FHP: Driver CAD model outputs against predefined requirements and acceptability criteria.					
15. SUBJECT TERMS Fixed Heel Point (FHP), occupant workspace, ensemble, verification, Computer-Aided Design (CAD), accommodation model, ground vehicle design, interior workspace, occupant, fixed heel point, target design population, posture prediction.					
16. SECURITY CLASSIFICATION OF:			17. LIMITATION OF ABSTRACT	18. NUMBER OF PAGES	19a. NAME OF RESPONSIBLE PERSON Gale L. Zielinski
a. REPORT UNLIMITED	b. ABSTRACT UNLIMITED	c. THIS PAGE UNLIMITED			260

Standard Form 298
(Rev. 8-98)
Prescribed by ANSI Std.

**TANK-AUTOMOTIVE RESEARCH
DEVELOPMENT ENGINEERING CENTER**

Warren, MI 48397-5000

9 November 2017
Revision 1.0

**TARDEC Fixed Heel Point (FHP): Driver
CAD Accommodation Model
Verification Report**

By

Frank J. Huston II and Gale L. Zielinski



REVISION HISTORY

Revision Number	Revision Date	Description of Change
1.0	9 November 2017	Original

CONTENTS

1.	VERIFICATION REPORT EXECUTIVE SUMMARY	9
2.	PROBLEM STATEMENT	10
2.1	Intended Use	10
2.2	M&S Overview	11
2.3	M&S Application	12
2.3.1	Model Origin	12
2.3.2	Model Inputs.....	13
2.3.3	Model Outputs – Seat travel and Occupant Composite body boundaries	14
2.3.4	Model Outputs – Occupant Clearances Based on MIL-STD-1472.....	16
2.3.5	Model Outputs - Direct Field of View And Ground INtercept Based on MIL-STD-1472 and SAE J1050	17
2.3.6	Model Outputs - Manikin Placement.....	20
2.4	Verification Scope	21
3.	REQUIREMENTS AND ACCEPTABILITY CRITERIA	22
4.	CAPABILITIES, LIMITATIONS, & ASSUMPTIONS (cla), RISKS/iMPACTS	25
4.1	M&S Capabilities	25
4.2	M&S Limitations.....	25
4.3	M&S Assumptions	26
4.4	M&S Risks/Impacts	26
5.	VERIFICATION TASK ANALYSIS	26
5.1	Data Verification Task Analysis	26
5.2	Model Verification Task Analysis.....	27
6.	VERIFICATION RECOMMENDATIONS.....	28
7.	KEY PARTICIPANTS.....	30
8.	ACTUAL VERIFICATION RESOURCES EXPENDED	31
8.1	Verification Resources Expended.....	31
8.2	Actual Verification Milestones and Timeline	31
9.	VERIFICATION LESSONS LEARNED	33
10.	APPENDICES.....	34
10.1	Appendix A – M&S Description	34
10.1.1	M&S Development and Structure	34
10.1.2	M&S Use History	36
10.1.3	Configuration Management	37
10.2	Appendix B – Requirements and Acceptability Criteria Results.....	38

10.2.1	Test #1 – Numerical Results	41
10.2.2	Test #2 – Numerical Results	42
10.2.3	Test #3 – Numerical results	43
10.2.4	Test #4 – Numerical results	44
10.2.5	Test #5 – Numerical results	45
10.2.6	Test #6 – Numerical results	46
10.2.7	Test #7 – Numerical results	47
10.2.8	Test #8 – Numerical results	48
10.2.9	Test #9 – Numerical results	49
10.2.10	Test #10 – Numerical results	50
10.3	Appendix C – References	51
10.4	Appendix D – Acronyms	53
10.5	Appendix E – Distribution List	54
10.6	Appendix F – Verification Plan	56
10.7	Appendix G - Initial Task Analysis.....	57
10.7.1	Test #1 – Baseline Comparison.....	63
10.7.2	Test #2 – Vary Steering Wheel Point in Fore-Aft (X) Direction.....	85
10.7.3	Test #3 – Vary SWP in Fore-Aft (X) and Vertical (Z) Position and Use Alternate HARP Tool	105
10.7.4	Test #4 – Vary SWP in Fore-Aft (X) Direction.....	125
10.7.5	Test #5 – Vary SWP in Fore-Aft (X) and Vertical (Z) Direction	145
10.7.6	Test #6 – Vary SWP in Fore-Aft (X) and Vertical (Z) Direction and Ensemble.....	165
10.7.7	Test #7 – Vary Target Accommodation and Ensemble.....	183
10.7.8	Test #8 – Vary Gender Mix and Ensemble.....	203
10.7.9	Test #9 – Vary Gender Mix and Ensemble.....	223
10.7.10	Test #10 – Vary Gender Mix, Ensemble, and Provide Hydration Pack Relief	241

LIST OF FIGURES

Figure 1: TARDEC Fixed Heel Point (FHP): Driver CAD Accommodation Model	10
Figure 2: Accelerator Heel Point in CAD	12
Figure 3: Example Input Parameter Table for FHP: Driver CAD model.....	14
Figure 4: FHP: Driver CAD Model Example Output.....	16
Figure 5: FHP CAD Accommodation Model Clearance Zone Outputs	17
Figure 6: Primary Vision Using Eyellipse in Creo.....	19
Figure 7: Secondary Vision Zone Using Eyellipse in Creo	19
Figure 8: Tertiary Vision Zone Using Eyellipse in Creo.....	20
Figure 9: Ground Intercept Line Using Eyellipse in Creo	20
Figure 10: Manikin Placement Using Posture Prediction Model	21

LIST OF TABLES

Table 1: FHP Accommodation Model Inputs	13
Table 2: FHP: Driver CAD Model Accommodation Boundary Outputs and Definitions.....	14
Table 3: FHP: Driver CAD Model Clearance Outputs and Definitions.....	16
Table 4: FHP: Driver CAD Model Vision Zone Outputs and Definitions	18
Table 5: Posture Prediction Model Output and Definitions based on Seated Soldier Study.....	21
Table 6: Requirements Relationship Table for Accommodation Model.....	22
Table 7: Requirements Relationship Table for Posture Prediction of Boundary Manikins	25
Table 8: FHP: Driver Accommodation Model Test Matrix	27
Table 9: Key Participants for FHP: Driver CAD Model Verification Effort	30
Table 10: Verification Resources	31
Table 11: Verification Milestone Timeline.....	32
Table 12: Accommodation Model Requirements Results	38
Table 13: Posture Prediction Model Results.....	40

ACKNOWLEDGEMENTS

The authors would like to acknowledge the contributions of the following individuals for their assistance in the creation of this report:

Cheryl A. Burns, Army Research Laboratory Human Research and Engineering Directorate (ARL HRED)

Richard W. Kozycki (ARL HRED)

Matthew P. Reed, PhD, University of Michigan Transportation Research Institute (UMTRI)

1. VERIFICATION REPORT EXECUTIVE SUMMARY

Military ground vehicles are currently designed using requirements from MIL-STD-1472G, the *Department of Defense Design Criteria Standard: Human Engineering*. The MIL-STD, however, is difficult for designers to apply properly because it is often open to interpretation. Easy-to-use Computer-Aided Design (CAD) tools are needed by the ground vehicle community to address this issue. The CAD tools being developed are called accommodation models. Accommodation models are constructed from 3D empirical data for a given seating configuration to provide population workspace boundaries that include the effects of both anthropometry and posture (Zielinski, Huston II, Kozycki, Kouba, & Wodzinski, 2015).

Accommodation models provide an opportunity to apply Human Systems Integration (HSI) much earlier in the acquisition process. The models can be utilized during the Material Solution Analysis Phase prior to Milestone (MS)A and through MSB. Past programs have not actively engaged HSI until MSB or the Engineering Manufacturing and Development (EMD) Phase, resulting in significant design and cost changes.

The TARDEC Fixed Heel Point (FHP): Driver CAD Accommodation Model described in this verification report is applicable to truck-like ground vehicles where driving is controlled via a conventional accelerator pedal and steering wheel. The model may also be used in workstations that require the crew to interact with vehicle controls and non-driving displays using hands, horizontal directed vision, and adjustable seats. The FHP: Driver CAD model is a parametric model that is intended to provide the composite boundaries representing the body of the defined target design population, including posture prediction. Clearances between the occupant and surrounding interior vehicle surfaces have been added per MIL-STD-1472G. Direct vision zones and ground intercept have been added based on MIL-STD-1472G and SAE Recommended Practice J1050.

The intention of verification is to build confidence in the CAD accommodation model. Model verification included ten test scenarios for comparing the FHP: Driver CAD model outputs against predefined requirements and acceptability criteria. Specifically, when given the same inputs, accommodation model geometry from the CAD model was compared to the outputs of the UMTRI *Soldier Driver Accommodation* (2017) model spreadsheet; and boundary manikin hip and eye locations were compared to the outputs of the *Seated Soldier Posture Prediction* (2014) spreadsheet. Because no other models for comparison exist, Subject Matter Experts (SMEs) were used to determine that CAD model outputs for occupant clearances matched the agreed upon interpretation of MIL-STD-1472G and that direct vision zones and the ground intercept matched the agreed upon interpretation for combining concepts presented in MIL-STD-1472G and SAE Recommended Practice J1050 (2009).

No issues were discovered during the verification of the model. The final outcome from the review was team consensus that the FHP: Driver CAD model passed verification.

2. PROBLEM STATEMENT

Military ground vehicles are currently designed using requirements from MIL-STD-1472G, the *Department of Defense Design Criteria Standard: Human Engineering*. The requirement to accommodate the central 90% of the Soldier population in which the fully equipped Soldier can sit safely and comfortably while performing all required functions, including driving, requires multivariate analysis methods so that both Soldier anthropometry and posture can be considered (DoD, 2012). MIL-STD-1472G is often open to interpretation and is therefore difficult for designers to apply consistently. Easy-to-use, valid design tools and procedures based on these methods are needed to effectively design vehicle workstations. The chosen tools are Computer-Aided Design (CAD) based accommodation models, Figure 1, adapted for Soldiers in military ground vehicles, that directly parallel long-standing SAE recommended practices used in the commercial automotive and truck domains (Zielinski, Huston II, Kozycki, Kouba, & Wodzinski, 2015). The first CAD model developed is the Tank Automotive Research, Development and Engineering Center (TARDEC) Fixed Heel Point (FHP): Driver CAD accommodation model, known throughout the rest of this report as the FHP: Driver CAD model.

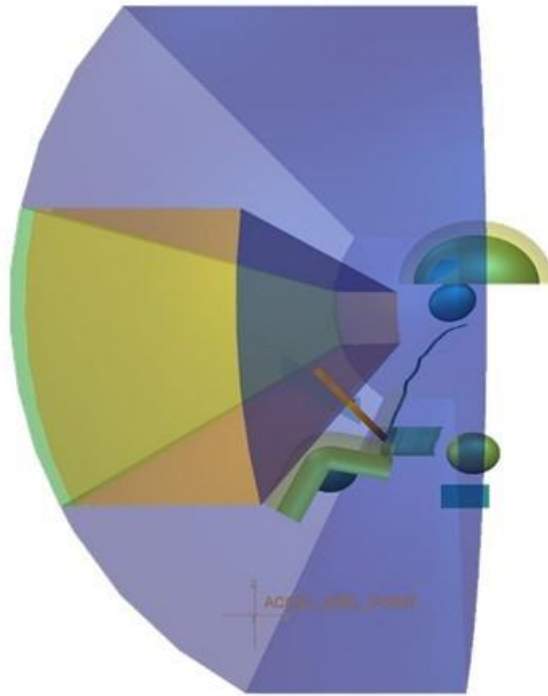

Figure 1: TARDEC Fixed Heel Point (FHP): Driver CAD Accommodation Model

2.1 INTENDED USE

The FHP: Driver CAD model described in this verification report is applicable to truck-like ground vehicles where driving is controlled via a conventional accelerator pedal and steering

wheel. The model may also be used in workstations that require the crew to interact with vehicle controls and non-driving displays using hands, horizontal directed vision, and adjustable seats.

The FHP: Driver CAD model is a parametric model that is intended to provide the composite boundaries representing the body of the defined target design population, including posture prediction. The boundaries defined include the required space and seat adjustments needed for the occupants' helmet, eyes, torso, knees, legs, and shins. Clearances between the occupant and surrounding interior vehicle surfaces have been added per MIL-STD-1472G (e.g. head clearance required from head (helmet) to vehicle roof line and thigh clearance to the steering wheel). Direct vision zones and ground intercept have been added based on MIL-STD-1472G and SAE Recommended Practice J1050, *Describing and Measuring the Driver's Field of View*, 2009.

It should be noted that CAD accommodation models serve as a design tool and are not intended to replace, but rather complement, Human Factors Engineering (HFE) assessment tools.

2.2 M&S OVERVIEW

The FHP: Driver CAD model is a statistical model created utilizing data collected in the *Seated Soldier Study* (2013) completed by the University of Michigan Transportation Research Institute (UMTRI). The original model, as provided by UMTRI, consists of a Microsoft Excel spreadsheet. The CAD version of the model was created using PTC Creo® 3D CAD software and is a stand-alone geometric reproduction of the output found in the UMTRI Microsoft Excel spreadsheet.

The primary model inputs describe the target driver population (a subset of the Army Anthropometric Survey (ANSUR) II) and the nominal location of the steering wheel. The target driver population is defined by gender mix, ensemble (clothing and equipment worn by the occupant), and the desired level of accommodation (e.g. 90%). The ensemble is selectable as either Personal Protective Equipment (PPE) which includes the Improved Outer Tactical Vest (IOTV) or Encumbered (ENC) which includes the PPE and Rifleman Ensemble, both of which are defined in the *Seated Soldier Study*. Ideally, the level of accommodation will be set at the central 90 percent of the target design population, to be consistent with MIL-STD-1472G requirements. The only vehicle input to the model is the location of the steering wheel, as determined by the Steering Wheel Point (SWP) (Zielinski et al., 2015).

The FHP: Driver CAD accommodation model represents the posture and position variability for the entire selected target design population (e.g. central 90%, 85% male). The model can guide vehicle designers in creating an optimized workspace for the occupant. The CAD accommodation model, along with additional added space claims for human factors, can be used to visualize MIL-STD-1472G requirements. This eliminates the concern that interpretations of the MIL-STD for creating occupant workspaces vary among vehicle designers (Zielinski et al., 2015).

2.3 M&S APPLICATION

The use of the FHP: Driver CAD model provides the opportunity to apply Human Systems Integration (HSI) very early in the acquisition process. The model can be utilized during the Material Solution Analysis Phase prior to Milestone (MS)A and through MSB. Past programs have not actively engaged HSI until MSB or the Engineering Manufacturing and Development (EMD) Phase, resulting in significant design and cost changes.

The FHP: Driver CAD model can be used to explore possible design tradeoffs when conflicts with other design parameters exist. Vehicle designers can use the model for the following scenarios: 1) during the concept and design phase of new acquisition programs, 2) while upgrading existing ground vehicle platforms, and 3) for assessing commercial off the shelf (COTS) systems. Human factors engineers could benefit by working with vehicle designers to perform virtual assessments in CAD when there is not enough time and/or funding to translate vehicle models into assessment software compatible formats and perform detailed human figure modeling.

2.3.1 MODEL ORIGIN

The Accelerator Heel Point (AHP) is the X and Z axis origin for the FHP: Driver CAD model. It is a reference point on the floor of the vehicle aft of the accelerator pedal. The AHP is constructed in side view using the undeflected accelerator pedal surface and the floor surface in the area of the pedal. AHP is defined by the intersection with the floor surface of a side-view line contacting the accelerator pedal surface and oriented at the Accelerator Plane Angle (APA) with respect to forward horizontal, Figure 2. APA is the angle with respect to forward horizontal of a reference plane used to define the accelerator heel point.

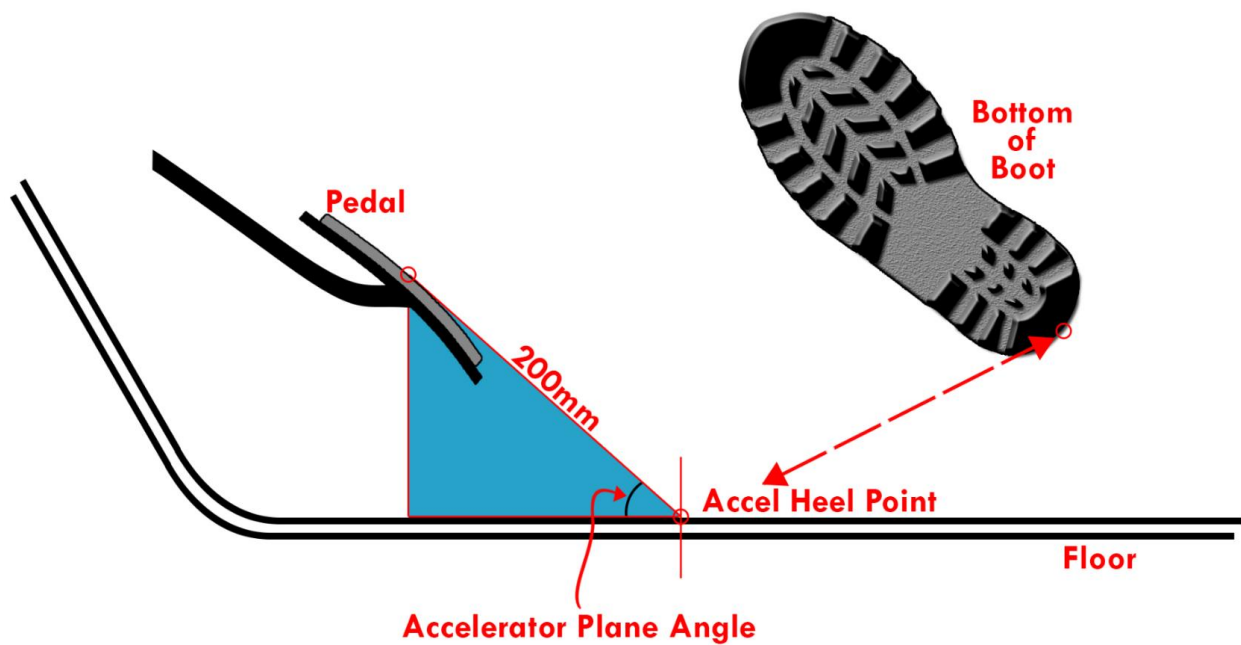

Figure 2: Accelerator Heel Point in CAD

2.3.2 MODEL INPUTS

Inputs to the FHP: Driver CAD model are shown below in Table 1. A sample of how the inputs appear in the model are shown in Figure 3.

Table 1: FHP Accommodation Model Inputs

Model Input	Description
Target Accommodation	The percentage of the target design population to be accommodated. The occupants not accommodated are evenly split between the smaller and larger extremes of the population. In MIL-STD-1472G (2012), the accommodation target has been set at 90%.
Fraction Male	The percentage of males in the defined target design population.
Ensemble	Clothing and equipment available for selection in the model: <ul style="list-style-type: none"> • ¹PPE = ACU + IOTV + ACH • ²ENC = PPE + Rifleman Ensemble
Steering Wheel Point (SWP)	The SWP is the effective center of the steering wheel and is reported in horizontal and vertical components with respect to the AHP (Reed, 2005).
Consider Hydration Pack Relief	A seatback with hydration pack relief can fully accommodate an occupant's hydration pack such that the occupant's position in the seat is the same regardless of wearing a hydration pack. The following selections are available in the model: <ul style="list-style-type: none"> • Yes • No
Human Accommodation Reference Point (HARP) Measurement Tool	The expected distribution of driver-selected seat positions relative to the AHP is predicted based on the seat design HARP measurement tool selected. The two options of seat design HARP measurement tools are the SAE J826 H-point manikin and ISO 5353 Seat Index Point (SIP) tool (Reed & Ebert, 2014). The following selections are available in the model: <ul style="list-style-type: none"> • SAE J826 • ISO 5353
Consider Censored Seating	Occupant workspaces in vehicles and/or COTS seat does not always provide the ideal amount of horizontal and vertical seat travel (or location of seat travel) for the target design population. This function is offered to calculate loss of ideal occupant accommodation. The following selections are available in the model: <ul style="list-style-type: none"> • Yes • No
Seat Travel Reduction Front	The amount of reduced seat travel at the front of the seat track travel range window, reported in inches.
Seat travel Reduction Rear	The amount of reduced seat travel at the rear of the seat track travel range window, reported in inches.
Seat Travel Reduction Top	The amount of reduced seat travel at the top of the seat track travel range window, reported in inches.

Seat Travel Reduction Bottom	The amount of reduced seat travel at the bottom of the seat track travel range window, reported in inches.
Consider Ground Intercept	If ground intercept requirements can be determined with respect to the AHP, a ground intercept line (line of sight) can be shown. The following selections are available in the model: <ul style="list-style-type: none"> • Yes • No
Distance AHP to Vehicle Front	The distance from the AHP to the front of the vehicle, reported in inches.
Distance AHP to Ground	The distance from the AHP to the ground, reported in inches.
Minimum Ground Intercept	The value for minimum ground intercept to be calculated based on vehicle requirement, reported in inches.

¹ Personal Protective Equipment (PPE), Advanced Combat Uniform (ACU), Improved Outer Tactical Vest (IOTV) that included Enhanced Small Arms Protective Insert (ESAPI) plates, Enhanced Side Ballistic Inserts (ESBI), and Advanced Combat Helmet (ACH).

² Encumbered (ENC), Rifleman Ensemble defined in the Soldier Load Configurations in Ground Vehicles (McNamara, 2012) and Seated Soldier Study (Reed et al, 2013).

Name	Type	Value	Desig...	Access	Source	Description	Restri...	Unit Q...	Unit
STEERING_WHEEL_X	Real Number	13.307087	<input type="checkbox"/>	Full	Program	Steering wheel "X" position (SAE L11) wrt AHP		Length	in
STEERING_WHEEL_Z	Real Number	28.937008	<input type="checkbox"/>	Full	Program	Steering wheel "Z" position (SAE H17) wrt AHP		Length	in
SOLDIER_GEAR_LEVEL	Integer	1	<input type="checkbox"/>	Full	Program	1 = PPE, 2 = ENC			
FULL_ACCOMMODATION_LEVEL	Real Number	0.900000	<input type="checkbox"/>	Full	Program				
PERCENT_MALE	Real Number	0.850000	<input type="checkbox"/>	Full	Program				
SEAT_MEASURING_TOOL	Integer	1	<input type="checkbox"/>	Full	Program	1 = SAE J826, 2 = SIPT			
SEAT_HAS_HYDRATION_PACK_RELIEF	Yes No	YES	<input type="checkbox"/>	Full	Program				

Figure 3: Example Input Parameter Table for FHP: Driver CAD model

2.3.3 MODEL OUTPUTS – SEAT TRAVEL AND OCCUPANT COMPOSITE BODY BOUNDARIES

The primary model outputs include the seat adjustment range needed to reach vehicle controls and the resulting positions for occupant population boundaries for eyes, helmet, torso, and knees. Model outputs are described below in Table 2 and shown in Figure 4.

Table 2: FHP: Driver CAD Model Accommodation Boundary Outputs and Definitions

Model Output	Description
Steering Wheel Preference Line	The steering wheel preference line depicts an acceptable range of Steering Wheel Points (SWPs) for the target driver population.
Steering Wheel Placeholder	The steering wheel placeholder represents the steering wheel used during data collection for

	the <i>Seated Soldier Study</i> but is not representative of a specific program steering wheel.
Seat Track Travel Range	The seat track travel range, shown in side view, represents the HARP travel path and boundaries of adjustments needed by the driver (Reed, 2015).
Seat Back Angle	A seat back angle adjustment range that will accommodate the desired fraction of the driver population (Reed, 2015).
Eyellipse	The eyellipse (a contraction of the words "eye" and "ellipse") depicts the distribution of driver eye locations in the vehicle (Reed, 2015).
Helmet Boundary	The helmet boundary depicts the distribution of target design population helmet locations in the vehicle. The Advanced Combat Helmet (ACH) was used (Reed, 2015).
Torso Boundary ENC and Torso Boundary PPE	The torso boundary depicts the distribution of driver torsos, including the effects of ensemble (Reed, 2015).
Knee Boundary Including Leg and Thigh	The knee boundary with leg and thigh depicts the top, forward, and lateral distribution of the resting knee location in vehicle.
Elbow Boundary	The elbow boundary depicts the distribution of resting elbow locations of the occupant (Reed, 2016).
Accelerator Plane Angle (APA)	APA is the angle with respect to forward horizontal of a reference plane used to define the accelerator heel point.

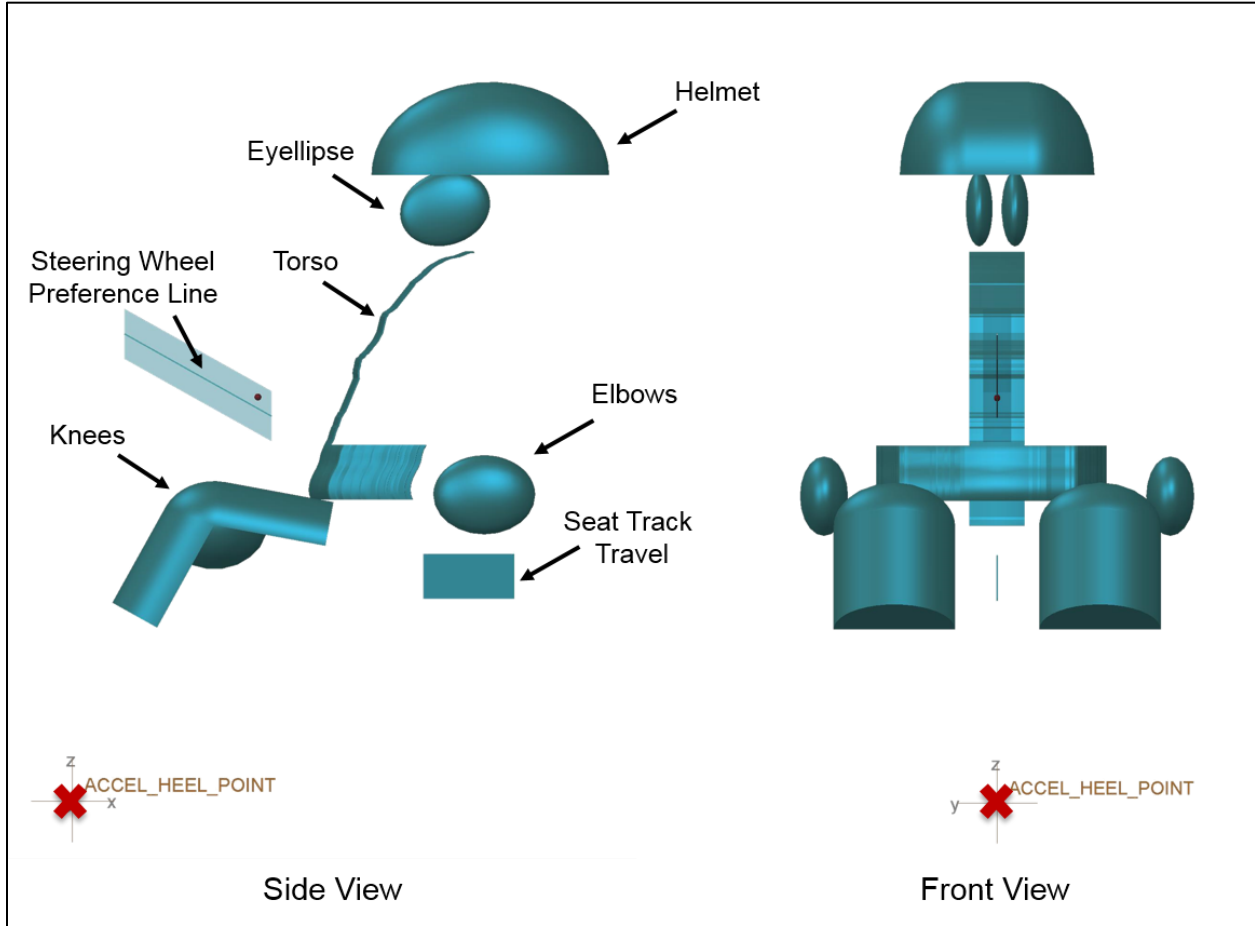

Figure 4: FHP: Driver CAD Model Example Output

2.3.4 MODEL OUTPUTS – OCCUPANT CLEARANCES BASED ON MIL-STD-1472

Clearance zones are included in the model to serve as a visual check for vehicle designers to utilize when creating the occupant workspace. Generally, 2 inches of clearance is required between the seated occupant and all vehicle structures and/or equipment. Model clearances are described below in Table 3 and shown in Figure 5.

Table 3: FHP: Driver CAD Model Clearance Outputs and Definitions

Model Output	Description
Clearance Helmet	Helmet clearance consists of an additional 2 inches of space claim required between the helmet boundary and the vehicle ceiling and nearby equipment.
Clearance Abdomen	Abdomen clearance consists of an additional 2 inches of space claim required between the seated occupant, with ensemble, and the steering wheel.
Clearance Knee, Leg, and Thigh	The knee, leg, and thigh clearance represents a 2 inch space claim required from the front

	and top of the knee and top and sides of legs and thighs to any surfaces such as the underside of the steering wheel or IP.
Clearance Elbow	Elbow clearance consists of an additional 2inches of lateral space claim required between the elbows, in a resting position, and nearby vehicle structures such as door trim.

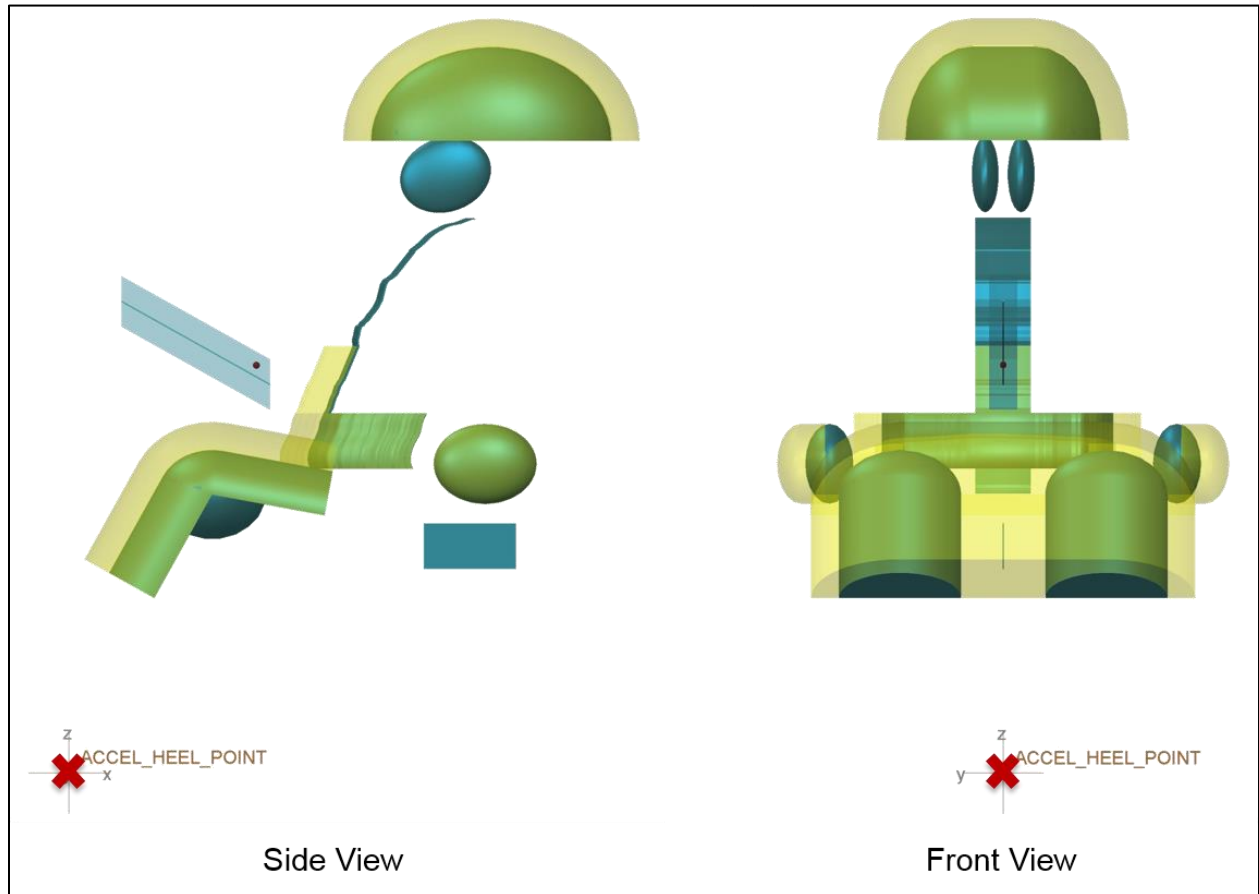

Figure 5: FHP CAD Accommodation Model Clearance Zone Outputs

2.3.5 MODEL OUTPUTS - DIRECT FIELD OF VIEW AND GROUND INTERCEPT BASED ON MIL-STD-1472 AND SAE J1050

The direct field of view has been divided into primary, secondary, and tertiary zones. The zones were developed with ARL HRED and UMTRI using a combination of vertical and horizontal visual fields described in MIL-STD-1472G and SAE J1050. When members of a population have different eye points, tangents to the eyellipse are used to determine field of view. (Huston II, Zielinski, & Reed, 2016). Model outputs are described below in Table 4 and shown in Figure 6, Figure 7, Figure 8.

Table 4: FHP: Driver CAD Model Vision Zone Outputs and Definitions

Model Output	Description
Vision Zone, Primary	The primary vision zone (Figure 6) indicates space viewable by all occupants from at least one eye using a minimum of “easy” eye rotation. Combining the limits of MIL-STD-1472G and SAE J1050, “easy” eye rotation is defined laterally as 15 degrees side-to-side from the occupant’s centerline and vertically as +15/-30 degrees from horizontal (Huston II, et. al, 2016).
Vision Zone, Secondary	The secondary vision zone (Figure 7) includes both “easy” eye rotation and “easy” head turn. Combining the limits of MIL-STD-1472G and SAE J1050, “easy” eye rotation and “easy” head turn is defined laterally as 60 degrees side-to-side from the occupant’s centerline (15 degrees eye + 45 degrees head) and vertically as +15/-30 degrees from horizontal (eye rotation only) (Huston II, et. al, 2016).
Vision Zone, Tertiary	The tertiary vision zone (Figure 8) includes both “max” eye rotation and “max” head turn. Combining the limits of MIL-STD-1472G and SAE J1050, “max” eye rotation and “max” head turn is defined laterally as 95 degrees side-to-side from the occupant’s centerline (35 degrees eye + 60 degrees head) and vertically as +45 degrees/-65 degrees from horizontal (eye rotation only).

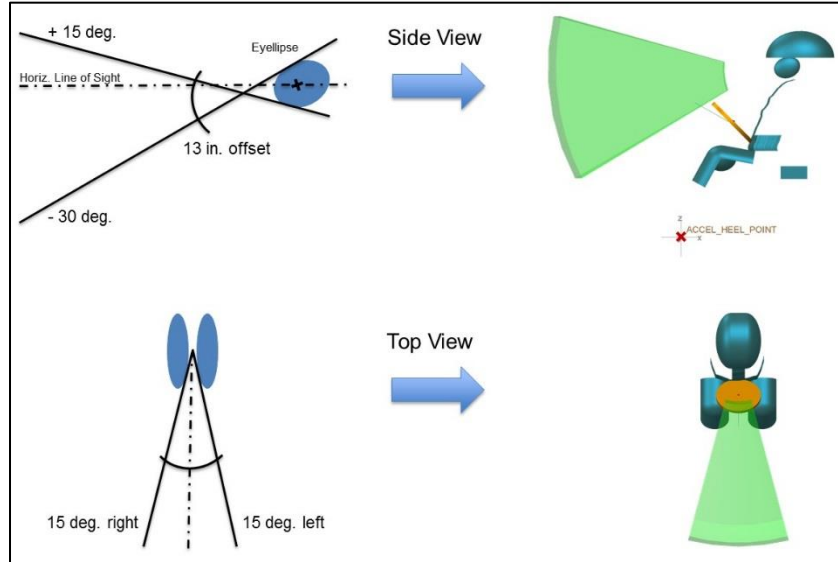

Figure 6: Primary Vision Using Eyellipse in Creo

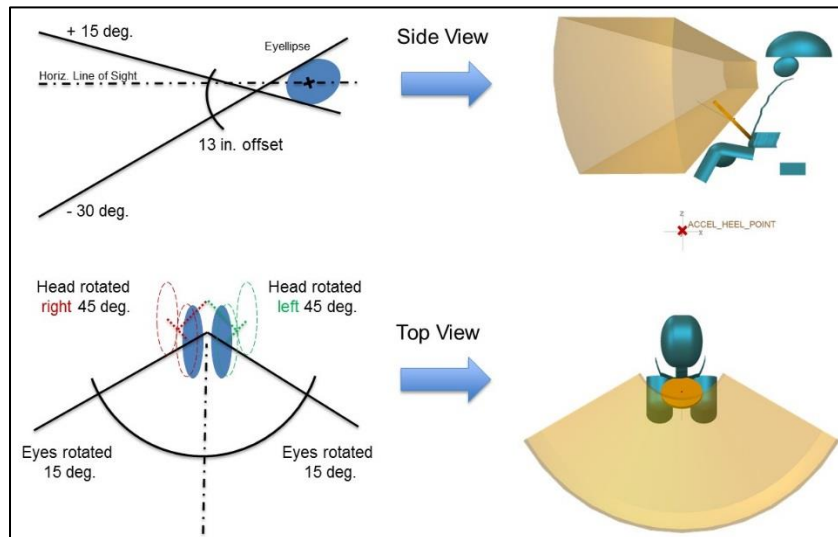

Figure 7: Secondary Vision Zone Using Eyellipse in Creo

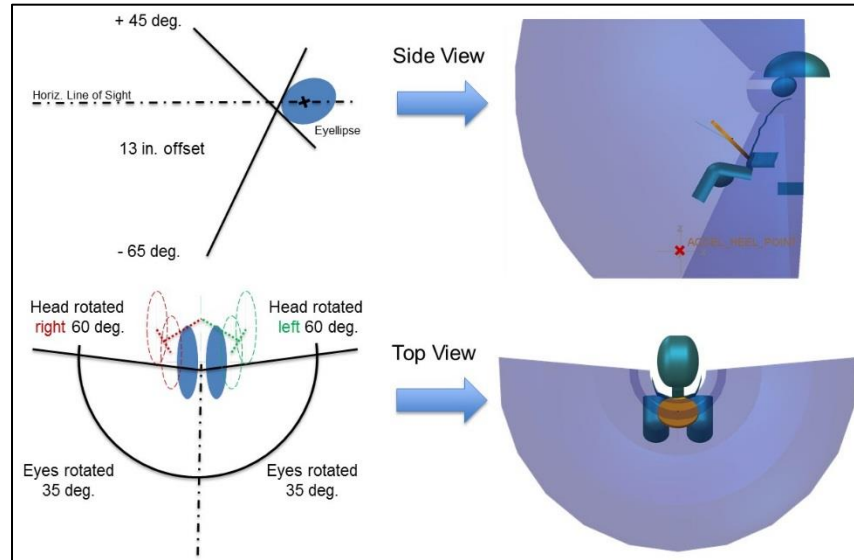

Figure 8: Tertiary Vision Zone Using Eyellipse in Creo

When the location of the occupant workspace is known with respect to the rest of the vehicle and the ground, the model is able to depict a best-case ground intercept using the eyellipse. An example of such a ground intercept is shown below in Figure 9. The tangent from the ground intercept to the lower side of the eyellipse represents the lowest sight line for the target population.

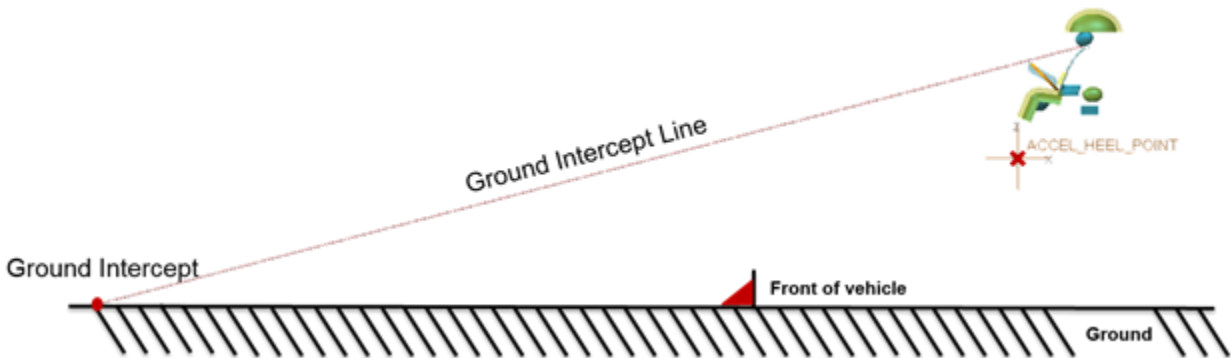

Figure 9: Ground Intercept Line Using Eyellipse in Creo

2.3.6 MODEL OUTPUTS - MANIKIN PLACEMENT

Using the same data underlying the creation of the accommodation boundaries, boundary manikins representing the anthropometric extremes of vehicle workstation design are placed in their nominal positions. This is helpful in understanding how specific individuals in the population fit into the vehicle and aids visualization for those unfamiliar with the accommodation boundaries (Huston II, et. al., 2016). Model outputs are described below in Table 5 and shown in Figure 10 for one of seven boundary manikins.

Table 5: Posture Prediction Model Output and Definitions based on Seated Soldier Study

Model Output	Description
Boundary Manikin Posture and Position	The Boundary Manikin Posture and Position predicts position and torso posture for a family of simulated drivers based on the vehicle configuration and the anthropometric inputs of stature, body weight, and erect sitting height (Reed, 2013).



Figure 10: Manikin Placement Using Posture Prediction Model

2.4 VERIFICATION SCOPE

This report documents the verification of the FHP: Driver CAD model, including the activities, results, and recommendations that were gathered during the verification effort. This report will be managed by the TARDEC accommodation model Project Lead and will be used to support any future enhancements to the FHP: Driver CAD model.

Verification of the model was performed on 01 August 2017 by the Verification Agents listed in Table 9, Section 7. TARDEC led the verification effort with participants from Army Research Laboratory (ARL) Human Research and Engineering Directorate (HRED), TARDEC Advanced Concepts Team (ACT), TARDEC Ground Vehicle Survivability and Protection (GVSP), TARDEC Center for System Integration (CSI), Marine Expeditionary Rifle Squad (MERS), and UMTRI.

The goal of verification was to evaluate the PTC Creo® 3D CAD version of the FHP: Driver CAD model, per the following:

- 1) Determine if the accommodation boundaries calculated by the TARDEC CAD model match those calculated by the UMTRI Microsoft Excel spreadsheet *Soldier Driver Accommodation Models 2017-06-08*
- 2) Determine if the clearance zones (helmet, abdominal, knees, legs, and shins) calculated by the TARDEC CAD model match the Subject Matter Expert (SME) interpretation of MIL-STD-1472G
- 3) Determine if the direct fields of view (primary, secondary, and tertiary) calculated by the TARDEC CAD model match the SME interpretation of MIL-STD-1472G and SAE J1050
- 4) Determine if the ground intercept calculated by the TARDEC CAD model matches the SME interpretation of the MIL-STD-1472G ground intercept requirement
- 5) Determine if the hip and eye points calculated by the TARDEC CAD model match those calculated by the UMTRI Microsoft Excel spreadsheet *Seated Soldier Posture Prediction 2014-09-01*

3. REQUIREMENTS AND ACCEPTABILITY CRITERIA

The FHP: Driver CAD model shall meet the requirements shown in Table 6 below:

Table 6: Requirements Relationship Table for Accommodation Model

#	M&S Requirement	Acceptability Criteria	Metrics/Measures
1	Model allows for input of the Steering Wheel Point (SWP) in “X” (horizontal) and “Z” (vertical) coordinates.	1.1 Input parameter is available for steering wheel position in X	1.1 Representative (Pass) / Non-Representative (Fail)
		1.2 Input parameter is available for steering wheel position in Z	1.2 Representative (Pass) / Non-Representative (Fail)
2	Model allows for selection of seat hydration pack relief in the seat	2.1 Hydration pack relief selection of “yes” in model	2.1 Representative (Pass) / Non-Representative (Fail)
		2.2 Hydration pack relief selection of “no” in model	2.2 Representative (Pass) / Non-Representative (Fail)
3	Model allows for selection of either SAE J826 or ISO 5353 for the Human Accommodation Reference Point (HARP) measurement tool	3.1 HARP measurement tool selection of SAE J826 in model	3.1 Representative (Pass) / Non-Representative (Fail)
		3.2 HARP measurement tool selection of ISO 5353 in model	3.2 Representative (Pass) / Non-Representative (Fail)
4	Model allows for input of the population gender mix (e.g. 85% Male : 15% Female)	4.1 Fraction male input option in model	4.1 Representative (Pass) / Non-Representative (Fail)
5	Model allows for selection of ensemble as either PPE or ENC	5.1 Ensemble selection of PPE in model	5.1 Representative (Pass) / Non-Representative (Fail)
		5.2 Ensemble selection of ENC in model	5.2 Representative (Pass) / Non-Representative (Fail)
6	Model allows for a target population input (e.g. 90%)	6.1 Target accommodation input option in model	6.1 Representative (Pass) / Non-Representative (Fail)

7	Model predicts the Steering Wheel Preference Line	7.1 Model outputs a Steering Wheel Preference Line and SWP that adjusts with different inputs	7.1 Representative (Pass) / Non-Representative (Fail)
		7.2 TARDEC CAD model matches the UMTRI spreadsheet	7.2 Representative (Pass) / Non-Representative (Fail)
8	Model predicts a preferred steering wheel placement zone per guidance provided in the UMTRI paper <i>Preferred Steering Wheel Locations for Fixed-Heel-Point Driver Stations 2016-09-20</i> (fore/aft) and draft MIL-STD-1472H (side/side)	8.1 Model outputs a steering wheel placement zone that adjusts with different inputs	8.1 Representative (Pass) / Non-Representative (Fail)
		8.2 TARDEC CAD model matches the UMTRI spreadsheet and MIL-STD-1472H	8.2 Representative (Pass) / Non-Representative (Fail)
9	Model predicts the Accelerator Pedal Angle (APA)	9.1 Model outputs an APA that adjusts with different inputs	9.1 Representative (Pass) / Non-Representative (Fail)
		9.2 TARDEC CAD model matches the UMTRI spreadsheet	9.2 Representative (Pass) / Non-Representative (Fail)
10	Model predicts the expected distribution of driver-selected seat positions relative to the accelerator heel point (AHP) based on the SAE J826 and ISO 5353 Seat Index Point (SIP) seat measurement tools	10.1 Model outputs fore/aft and vertical seat track travel window for a given population and gender mix that adjusts with different inputs	10.1 Representative (Pass) / Non-Representative (Fail)
		10.2 TARDEC CAD model matches the UMTRI spreadsheet	10.2 Representative (Pass) / Non-Representative (Fail)
11	Model predicts the expected (dis)accommodation of driver-selected seat positions relative to the accelerator heel point (AHP) if the seat travel is censored	11.1 Model outputs (dis)accommodation value of a censored seat travel that adjusts with model inputs	11.1 Representative (Pass) / Non-Representative (Fail)
		11.2 TARDEC CAD model matches the UMTRI spreadsheet	11.2 Representative (Pass) / Non-Representative (Fail)
12	Model predicts the seat back angle adjustment range	12.1 Model outputs a range of seta back angles measured from vertical and adjusts with different inputs for the population	12.1 Representative (Pass) / Non-Representative (Fail)
		12.2 TARDEC CAD model matches the UMTRI spreadsheet	12.2 Representative (Pass) / Non-Representative (Fail)
13	Model predicts the dimensions and location of the eyellipse with respect to AHP and mean seat travel	13.1 Model outputs a left and right eyellipse for a given population and gender mix that adjusts with different inputs	13.1 Representative (Pass) / Non-Representative (Fail)
		13.2 TARDEC CAD model matches the UMTRI spreadsheet	13.2 Representative (Pass) / Non-Representative (Fail)
14	Model predicts the helmet contour boundary (helmet locations) with respect to the eye location and fitted to the eyellipse	14.1 Model outputs a helmet contour for the given population and gender mix that adjusts with the different inputs	14.1 Representative (Pass) / Non-Representative (Fail)
		14.2 TARDEC CAD model matches the UMTRI spreadsheet	14.2 Representative (Pass) / Non-Representative (Fail)
15	Model predicts the knee contour with leg and thigh segment angles based on location of resting drivers' knees in vehicle	15.1 Model outputs a knee ellipsoid for the given population and gender mix that adjusts with different inputs	15.1 Representative (Pass) / Non-Representative (Fail)
		15.2 TARDEC CAD model matches the UMTRI spreadsheet	15.2 Representative (Pass) / Non-Representative (Fail)
16	Model predicts torso contour with selected ensemble	16.1 Model predicts a torso contour with ensemble for the	16.1 Representative (Pass) / Non-Representative (Fail)

		given population, gender mix, and ensemble configuration that adjusts with different inputs	
		16.2 TARDEC CAD model matches the UMTRI spreadsheet	16.2 Representative (Pass)/ Non-Representative (Fail)
17	Model predicts elbow contours based on location of resting drivers' elbows in vehicle	17.1 Model outputs elbow contours for the given population and gender mix that adjusts with different inputs	17.1 Representative (Pass)/ Non-Representative (Fail)
		17.2 TARDEC CAD model matches the UMTRI spreadsheet	17.2 Representative (Pass)/ Non-Representative (Fail)
18	Model provides a clearance zone for the head (helmet) to roof line based on a back calculation from MIL-STD-1472G requirements	18.1 Model outputs a 2" clearance zone from the top of the helmet contour that adjusts with the different inputs	18.1 Representative (Pass) / Non-Representative (Fail)
19	Model provides a clearance zone for the knee, leg and thigh based on MIL-STD-1472H draft recommendations	19.1 Model outputs a 2" clearance zone from the top and front of the knee contour and the front of the leg segment and top of the thigh (in side-view) and adjusts with different inputs	19.1 Representative (Pass) / Non-Representative (Fail)
20	Model provides a clearance zone for the torso boundary, with selected ensemble, based on MIL-STD-1472H draft recommendations	20.1 Model outputs a 2" clearance zone forward from the torso boundary and adjusts and adjusts with the different inputs	20.1 Representative (Pass) / Non-Representative (Fail)
21	Model provides a lateral clearance zone for the elbow contours based on MIL-STD-1472H draft recommendations	21.1 Model output provides a 2" clearance zone laterally for the resting elbow contours	21.1 Representative (Pass)/ Non-Representative (Fail)
22	Model provides direct field of view (primary, secondary, and tertiary zones) based on MIL-STD-1472G and SAE J1050	22.1 Model outputs primary vision zone that adjusts with model inputs	22.1 Representative (Pass)/ Non-Representative (Fail)
		22.2 Model outputs secondary vision zone that adjusts with model inputs	22.2 Representative (Pass)/ Non-Representative (Fail)
		22.3 Model outputs tertiary vision zone that adjusts with model inputs	22.3
23	Model provides a ground intercept	23.1 Model outputs a line tangent to the bottom of the eyellipse to the ground and adjusts with different user inputs	23.1 Representative (Pass)/ Non-Representative (Fail)

Along with using the FHP: Driver CAD model, ground vehicle designers will use boundary manikins when creating the interior workspace. The boundary manikins are postured and positioned in CAD using equations from the posture prediction model created by UMTRI. The requirements for posture prediction are shown in Table 7 below:

Table 7: Requirements Relationship Table for Posture Prediction of Boundary Manikins

#	M&S Requirement	Acceptability Criteria	Metrics/Measures
1	Model predicts the location of the hip with respect to the AHP	1.1 Model outputs the location of the hip with respect to the AHP that matches the UMTRI spreadsheet	1.1 Representative (Pass) / Non-Representative (Fail)
		1.2 The manikin hip joint center aligns with the hip point	1.2 Representative (Pass) / Non-Representative (Fail)
2	Model predicts the location of the eye with respect to the AHP	2.1 Model outputs the location of the eye with respect to the AHP that matches the UMTRI spreadsheet	2.1 Representative (Pass) / Non-Representative (Fail)
		2.2 The manikin eye aligns with the eye point	2.2 Representative (Pass) / Non-Representative (Fail)

Numerical values calculated by both the TARDEC CAD model and the UMTRI Microsoft Excel spreadsheets must match within +/- 0.100 inches or +/- 0.100 degrees to be considered equivalent.

4. CAPABILITIES, LIMITATIONS, & ASSUMPTIONS (CLA), RISKS/IMPACTS

4.1 M&S CAPABILITIES

The FHP: Driver CAD model will provide government and industry partners with the following M&S capabilities:

- Seat travel (positioned in-vehicle) and seat back angle
- Relevant population boundaries for occupant posture in a crew workstation
- Posture prediction for the identified boundary manikins
- Clearances based on interpretation of MIL-STD-1472G
- Direct Field-of-View (FOV) based on a combination of vertical and horizontal visual fields from MIL-STD-1472G and SAE J1050
- Ground intercept based on interpretation of MIL-STD-1472G

4.2 M&S LIMITATIONS

The FHP: Driver CAD model has limitations based on the ground vehicle requirements for the crew workspace, as follows:

- Predicts fixed heel point driving conditions only (and limited commander positions) and does not address other special driving conditions such as fixed eye point (FEP), open protected or out-of-hatch (OOH) positions
- Cannot be used if a fixed seat back angle is required for the crew positions
- Cannot be used if horizontal and vertical seat travel are not integrated into the seat design

- Predicts where the occupant ideally wants to posture and position themselves but does not take into consideration posture changes due to restricted environments such as small transparent armor, low ceiling height, etc.
- Specific set of ensembles were defined for model creation. If clothing and equipment requirements for the program deviate greatly from the available selections in the model, a review of the details of the ensemble will need to be completed to confirm the model's applicability.

4.3 M&S ASSUMPTIONS

The development of a valid FHP: Driver CAD model is based on the following assumptions:

- The fixtures created and used by UMTRI to collect the occupant data are representative of a fixed heel point driver workspace
- Analysis methods used by UMTRI accurately predict occupant preferred posture and position
- Position data collected in a static environment over a short period of time are reasonably similar to occupants' preferred postures and positions during long-duration driving

4.4 M&S RISKS/IMPACTS

The constraints and limitations highlighted above could potentially result in an interior workspace design that is not fully optimized. This risk will be mitigated by Subject Matter Experts (SMEs) from ARL HRED who complete human factors assessments on the proposed designs, COTS vehicles, and demonstrators during the acquisition process per IAW AR 602-2. This assessment will be captured in documentation completed by the ARL HRED SMEs.

5. VERIFICATION TASK ANALYSIS

5.1 DATA VERIFICATION TASK ANALYSIS

No specific data verification tasks were completed because UMTRI, as the data developer, documented the methods and results of the data collection. The data and statistical techniques employed by UMTRI are appropriate for the creation of the models. Standard anthropometric data, which correlated to ANSURII data, was collected on the study participants. A whole-body laser scanner was used to record body shape in both seated and standing postures. Statistical analysis of body landmark data was conducted by UMTRI and validation of the data for the models to predict occupant posture, as a function of vehicle factors, was completed (Reed, et al, 2013). The UMTRI documents capturing this work are listed below:

- Seated Soldier Study: Posture and Body Shape in Vehicle Seats, Final Report UMTRI-2013-13
- Development of Accommodation Models for Soldiers in Vehicles, Final Report UMTRI-2014-26

- Seated Soldier Elbow Clearance Zones, 2016-12-10
- Preferred Steering Wheel Locations for Fixed-Heel-Point Driver Stations, 2016-09-20
- Soldier Driver Accommodation 2017-06-08, UMTRI Excel spreadsheet
- Seated Soldier Posture Prediction 2014-09-01, UMTRI Excel spreadsheet

The information provided by UMTRI was utilized to create the FHP: Driver CAD model.

5.2 MODEL VERIFICATION TASK ANALYSIS

Model verification included a total of ten tests, shown below in Table 8, to compare outputs from the FHP: Driver CAD model to the UMTRI Soldier Driver Accommodation (2017) spreadsheet and Seated Soldier Posture Prediction (2014) spreadsheets. The highlighted values in the table indicate which inputs were changed from the previous test.

Table 8: FHP: Driver Accommodation Model Test Matrix

Test #	Target Accommodation	Fraction Male	Ensemble	Steering Wheel Point (SWP) (measured wrt AHP)		Hydration Pack Relief Availability	HARP Measurement Tool
				X (in.) (L11, fore-aft)	Z (in.) (H17, vertical)		
1	90%	90%	PPE	8.9	30.9	No	SAE J826
2	90%	90%	PPE	14.8	30.9	No	SAE J826
3	90%	90%	PPE	13.3	29.0	No	ISO 5353
4	90%	90%	PPE	11.8	29.0	No	SAE J826
5	90%	90%	PPE	17.7	27.0	No	SAE J826
6	90%	90%	ACU	13.3	29.0	No	SAE J826
7	95%	90%	ENC	13.3	29.0	No	SAE J826
8	90%	50%	PPE	13.3	29.0	No	SAE J826
9	90%	50%	ACU	13.3	29.0	No	SAE J826
10	90%	50%	ENC	13.3	29.0	Yes	SAE J826

Tests #1-6 primarily explore the effects of varying the Steering Wheel Point (SWP)

- Geometry and position for the Steering Wheel Preference Line and Steering Wheel Zone are constant (because the underlying population remains the same across these tests)
- Geometry for Seat Track Travel and composite body boundaries (except knees) is constant, but position varies
- Knee Boundary geometry and position are unique for each test to reflect changing shin and thigh angles
- Changing the HARP measurement tool only affects the position of Seat Track Travel

Test #7 primarily explores the effects of varying Target Accommodation

- Geometry for Seat Track Travel and composite body boundaries increase in size with increased Target Accommodation

Tests #8-10 primarily explore the effects of using a different gender mix (Fraction Male) and varying the Ensemble

- Geometry for Seat Track Travel and composite body boundaries decrease in size with a smaller proportion of males. This is because women are generally smaller than men.
- Position for Seat Track Travel and composite body boundaries vary with the chosen ensemble. This is because Soldiers tend to put their bodies in the same position regardless of the ensemble worn. They move the seat to make up for displacement caused by their worn equipment.

Results from the above tests have been reported both in terms of passing or failing the requirements and acceptability criteria presented previously in Section 3 and screenshots showing how calculated numerical results were translated into CAD and compare to UMTRI's results. Please refer to the following appendices:

- Appendix B – Requirements and Acceptability Criteria Results
- Appendix G - Initial Task Analysis

6. VERIFICATION RECOMMENDATIONS

Team consensus from the verification event is that the FHP: Driver CAD model passed verification with no outstanding issues requiring corrective action. The following recommendations, applicable to the FHP: Driver CAD model and/or future planned accommodation models, were discussed by the team during the review:

- Steering Wheel Placement
 - Understand acceptable variability of steering wheel angle and diameter (requires funding to complete a study)
 - Create design criteria for steering wheel placement and add to design guide
 - Create design guidance for occupant egress with respect to steering wheel placement (may require funding to complete a study)
 - Create zones for pedal placement (requires funding to complete a study)
- Accelerator Plane Angle
 - Add a note to the user guide clarifying that the Accelerator Heel Point (AHP) in the CAD model is different than the heel point of accelerator mentioned in Table XXX, item #7 of MIL-STD-1472
- Seat Track Travel
 - Establish a means to determine the amount of vertical seat travel needed to achieve a specific ground intercept and define the process in the user guide
- Helmet Contour
 - During development of the Fixed Eye Point (FEP): Driver model, consider the number of vision blocks needed and adjust the helmet contour accordingly to account for any additional head turn (may require funding for a study)

- Confirm that the FHP helmet contour was developed using methodology from SAE Recommended Practice J1052 and note this fact in the user guide
- Elbow Contour
 - During development of the FEP: Driver model, consider adding rearward elbow clearance
 - In future accommodation modeling efforts, consider situations that affect elbow position such as the use of keyboards or obstacles such as nearby seat posts. Review the clearance zone that will be created for the Fixed Seat: Non-Driver model with human factors SMEs
 - Make any necessary adjustments to the FHP: Driver CAD model after the FEP and Fixed Seat models have been completed
 - Apply the FHP: Driver CAD model to the M-ATV CAD to determine if the clearance zone would have predicted interference with the door as currently seen in theatre
- Vision Zones
 - In the user guide, explain the development of min/max vision zone distances
 - In the user guide, explain how head turn was taken into account in the development of the vision zones (reference SAE Recommended Practice J1050)
- Ground Intercept
 - In the user guide, explain how to use the model's ground intercept function to explore various ground intercept values
 - Consider adding an up vision line to top of window similar to the ground intercept selection

The Verification Agents presented the team with the following recommended next steps for the FHP: Driver CAD model:

- Dissemination of the model
 - Load the model into PDMLink for internal use and for use by authorized U.S. Government Agencies and their contractors who are on Government contract or have a valid need to know
 - Submit model for OPSEC and load the approved version on TARDEC's public facing website (under development as of this writing) for all other potential users
- Documentation of the model
 - Complete the *TARDEC FHP: Driver CAD Accommodation Model Verification Report*, submit for OPSEC, and load the approved version to DTIC
 - Develop a user guide for the model that includes HFE design guidance input from ARL HRED, and load it to both PDMLink and TARDEC's public facing website (a version approved through OPSEC)
- Further model development

- Working with UMTRI, develop a process to define the Human Accommodation Reference Point (HARP) for use when only seat CAD, but not physical seats, is available (requires funding to complete a study)
- Determine final approach, funding, and timing necessary to complete model validation

7. KEY PARTICIPANTS

Table 9 identifies the participants involved in the verification effort, including their roles and responsibilities.

Table 9: Key Participants for FHP: Driver CAD Model Verification Effort

Verification Function	Description	Responsible M&S
M&S Proponent	The organization that has primary responsibility for M&S planning and management that includes development, verification and validation, configuration management, maintenance, use of the model or simulation, and others as appropriate. A Government entity.	Frank J. Huston II, TARDEC ACT Gale L. Zielinski, TARDEC ACT
M&S User	The individual, group, or organization that uses the results or products from a specific application of the model or simulation.	Gary L. Bronstetter, TARDEC ACT Kenneth M. Reeves, TARDEC ACT Gale M. Litrichin, TARDEC GVSP Eric S. Paternoster, TARDEC CSI ARL HRED Government Contractors
Verification Agent	The organization designated by the M&S proponent to perform verification of a model, simulation, or federation of M&S.	Frank J. Huston II, TARDEC ACT Gale L. Zielinski, TARDEC ACT
M&S Developer	The individual, group or organization responsible for developing or modifying a model or simulation in accordance with a set of design requirements and specifications.	Frank J. Huston II, TARDEC ACT Matthew P. Reed, Ph.D, UMTRI
SMEs	Individual who, by virtue of education, training, or experience, has expertise in a particular technical or operational discipline, system, or process.	Frank J. Huston II, TARDEC ACT Gale L. Zielinski, TARDEC ACT Cheryl A. Burns, ARL HRED Richard W. Kozycki, ARL HRED Joseph R. Urda, ARL HRED David A. Hullinger, ARL HRED Brian D. Corner, PhD, MERS - SIAT Matthew P. Reed, Ph.D, UMTRI

8. ACTUAL VERIFICATION RESOURCES EXPENDED

8.1 VERIFICATION RESOURCES EXPENDED

Table 10 identifies the resources used to create the TARDEC FHP: Driver CAD model and complete associated activities, including verification.

Table 10: Verification Resources

Document/Deliverable	Required Resources	POC
FHP: Driver Accommodation Model Proof of Concept	M&S Developer and SME support	TARDEC ACT
The Seated Soldier Study: Posture and Body Shape in Vehicle Seats Final Report	M&S Developer and SME support	UMTRI
Seated Soldier Posture Prediction Excel Spreadsheet	M&S Developer and SME support	UMTRI
Development of Accommodation Models for soldiers in Vehicles – Driver Final Report	M&S Developer and SME support	UMTRI,
FHP: Driver Accommodation Model Alpha Build	SME support	TARDEC ACT
FHP: Driver Accommodation Model Proof of Concept Introduction Report	SME support	TARDEC ACT
FHP: Driver Accommodation Model Funding Approval for FY16	SME support	TARDEC ACT
Soldier Driver Accommodation Model Excel Spreadsheet	M&S Developer and SME support	UMTRI
FHP: Driver Verification and Validation Plan	Verification Agent, M&S Developer and SME support	TARDEC ACT
FHP: Driver Accommodation Model Funding Approval (FY17)	SME support	TARDEC ACT
FHP: Driver Accommodation Model MOA (ARL HRED/TARDEC)	SME support	ALR HRED
FHP: Driver Accommodation Model Beta Build	SME support	TARDEC ACT
FHP: Driver Accommodation Model Verification packet completed	M&S Developer and Verification Agent	TARDEC ACT, UMTRI
FHP: Driver Model Release into PDMLink	SME support	TARDEC ACT
FHP: Driver Verification Report Revision 1.0	Verification Agent, Validation Agent, M&S Developer and SME support	TARDEC ACT

8.2 ACTUAL VERIFICATION MILESTONES AND TIMELINE

Table 11 identifies the major milestone achievements in the creation the FHP: Driver CAD model and completion of associated activities, including verification.

Table 11: Verification Milestone Timeline

Document/Deliverable	Delivery Date
FHP: Driver CAD Model Proof of Concept	February 2013
Posture Prediction Final Spreadsheet	September 2014
FHP: Driver Accommodation Model Final Report from UMTRI	September 2014
FHP: Driver CAD Model Alpha Build	December 2014
FHP: Driver Verification and Validation Plan	February 2016
FHP: Driver Model Final Accommodation Model Spreadsheet	February 2016
FHP: Driver CAD Model Beta Build	December 2016
FHP: Driver Verification and Validation Plan – RevA	January 2017
Functional Posture integrated with CAD Boundary Manikins	March 2017
FHP: Driver CAD Model Verification Complete	August 2017
FHP: Driver CAD Final Model Release into PDMLink	November 2017
Verification Report (Final)	November 2017

9. VERIFICATION LESSONS LEARNED

Verification of the FHP: Driver CAD model marks the first time that TARDEC has verified such a product. Before the verification event, the M&S Proponents and Developers determined that verifying CAD outputs against UMTRI's spreadsheet, given the number of calculations involved, would be too time intensive to complete in front of a live audience. Alternatively, a PowerPoint document (see Appendix G - Initial Task Analysis) was compiled for early distribution to all participants. This gave participants flexibility to focus on tests of particular interest during the verification event.

10. APPENDICES

10.1 APPENDIX A – M&S DESCRIPTION

10.1.1 M&S DEVELOPMENT AND STRUCTURE

The information in this Appendix is extracted from *Creation of the Driver Fixed Heel Point (FHP) CAD Accommodation Model for Military Ground Vehicle Design* (2016).

Ensuring that a given percentage of the population can sit safely and naturally while performing all required functions, including driving, requires multivariate analysis methods that consider the physical dimensions of the Soldier (anthropometry) and behavioral effects (posture) in a three dimensional space (DoD, 2012). This analysis is available for the FHP: Driver position as Soldier-specific statistical population accommodation models, developed by UMTRI, that parallel long-standing Society of Automotive Engineers (SAE) recommended practices used in the commercial automotive and truck domains. Because vehicle designs are developed from the early concept stages forward using CAD software, UMTRI's work has been encoded into a parametric CAD template that adjusts based on user inputs describing the Soldier population, desired accommodation level, and vehicle environment.

The primary developments that have made it possible to create a reusable CAD template representing FHP accommodation are UMTRI's predictive models for Soldier posture and the utilization of automated design capabilities available in many current CAD systems.

The automotive industry began introducing statistical population models into vehicle design in the 1960s to better understand various aspects of driver posture. The Seated Soldier Study (Reed and Ebert, 2013) was completed to capture Soldier preferred posture and position data in a driver mockup while considering the unique ground vehicle workstation environment and the clothing and equipment ensembles worn by Soldiers.

The Seated Soldier Study gathered data on 145 enlisted men and women as drivers at three Army posts. Soldiers wore three levels of clothing and equipment including: 1) the advanced combat uniform (ACU), consisting of the Soldier's own jacket, trousers, shirt, and combat boots; 2) personal protective equipment (PPE), consisting of the ACU plus an Improved Outer Tactical Vest (IOTV), Enhanced Small Arms Protective Insert (ESAPI) plates, Enhanced Side Ballistic Inserts (ESBI), and an Advanced Combat Helmet (ACH); and 3) encumbered (ENC), consisting of the ACU and PPE, plus a hydration pack and a Tactical Assault Panel (TAP) with a Rifleman equipment kit (Reed and Ebert, 2013).

The driver mockup simulates a Fixed Heel Point (FHP) driver workstation, including an accelerator pedal, steering wheel, and adjustable seat. When Soldiers entered the driver mockup, they found their preferred driving position by adjusting the seat's fore-aft (horizontal) and up-down (vertical) positions, as well as seat back angle. Each Soldier's posture and seat position was then digitized.

UMTRI's analysis of the data yielded both the average postures for individuals as a function of their body size and equipment level and accommodation boundaries capturing posture variability for everyone across the target population. In particular, the accommodation boundaries indicate the seat adjustment range needed to reach vehicle controls and the resulting positions for the equipped Soldier population's eyes, helmet, torso, and knees. Working models were provided by UMTRI in the form of Microsoft Excel spreadsheets. For a more in-depth discussion of UMTRI's work, please refer to the Seated Soldier Study (Reed and Ebert, 2013) and Development of Accommodation Models for Soldiers in Vehicle — Driver (Zerehsaz et. al., 2014).

The CAD version of the FHP: Driver accommodation model was created by TARDEC ACT using PTC Creo® 3D CAD software. Functionally, the foundation of the model is a stand-alone geometric reproduction of UMTRI's Microsoft Excel spreadsheets. Clearances between the Soldier population and surrounding interior vehicle surfaces were layered onto the model per the intent of MIL-STD-1472G, along with direct vision zones and a ground intercept tool that incorporate concepts from both MIL-STD-1472G and SAE Recommended Practice J1050, *Describing and Measuring the Driver's Field of View*, 2009. To aid in understanding how workstation design affects individuals, boundary manikins representing the anthropometric extremes for workstation design were placed in their predicted postures.

After building a static version of the accommodation model (i.e., a single instance of the possible combinations of Soldier population, desired accommodation level, and vehicle environment inputs), the process of automating the model began. This was done using a tool within Creo known as Pro/PROGRAM. Most CAD users already take advantage of the parametric nature of today's design software. For example, depending on how a model is constructed, simple changes can be propagated throughout by delving into a model's geometry and modifying dimensions. Pro/PROGRAM takes this concept a step further and allows for control of a model from outside the model tree, using relations and rules. End users of the FHP: Driver accommodation model are able to modify a list of parameters that are tied to the underlying geometry. Logical expressions are used to determine which portions of the Pro/PROGRAM code to execute for a given set of input values.

UMTRI's spreadsheets provide the values necessary to reproduce the relatively simple geometric elements comprising the accommodation boundaries (e.g. centroids and axis lengths for several ellipsoids). It was possible to encode the equations from UMTRI's spreadsheets into Creo without modification or the need for further calculations, with two notable exceptions. Because the majority of human anthropometric dimensions are normally distributed, the standard normal cumulative distribution function (CDF) is used throughout UMTRI's work to determine values at the desired level of accommodation. Creo does not contain an equivalent to Microsoft Excel's NORM.DIST function, so the following logistic approximation, having a maximum error of

0.00014 at $z = \pm 3.16$, was used instead (Bowling, Khasawneh, Kaewkuekool, and Rae Cho, 2009).

$$F(z) \sim \frac{1}{1 + e^{-(0.07056 * z^3 + 1.5976 * z)}}$$

The second exception involves the positioning of manikins. UMTRI provides coordinates of body landmarks with respect to the geometric origin of the accommodation model (i.e. the AHP, the lowest intersection of the manikin's heel with the floor when the foot is on the undepressed accelerator pedal) sufficient to locate the hips, torso articulation, and head. To place these coordinates into the reference systems of the boundary manikins (an axis system located between the hips of each manikin and aligned with the torso) and calculate the joint angles needed to position the limbs in three-dimensional space, Euclidean transformations for both translation and rotation were used.

10.1.2 M&S USE HISTORY

10.1.2.1 PROOF OF CONCEPT

The proof of concept for the FHP: Driver CAD model was created for the Occupant Centric Platform (OCP) Technology Enabled Capability Demonstration (TECD). The underlying accommodation modeling, based on the commercial large truck environment (Class-B vehicles), was originally developed by UMTRI for the International Truck and Engine Corporation. This model was the closest match in UMTRI's repertoire to any Army ground vehicle applications. The proof of concept CAD model was applied to the OCP Light Demonstrator concept. More detailed information regarding the development and use of the proof of concept CAD FHP: Driver model can be found in the *OCP TECD Report Introduction to Boundary Manikins and Accommodation Models for Military Ground Vehicle Occupant Centric (OC) Design* (2015).

10.1.2.2 ALPHA VERSION

The alpha version of the FHP: Driver CAD model has two primary distinctions from its predecessor. First, it is based on empirical Soldier data from the *Seated Soldier Study* instead of the U.S. civilian truck driver population. Second, all of the data and calculations from UMTRI's Microsoft Excel spreadsheets are encoded in the model to allow for standalone operation. The alpha version of the FHP: CAD model was applied to the Joint Tactical Transportation System (JTTS), created at TARDEC. The model provided valuable feedback to the CAD M&S Developer regarding questions ground vehicle designers may have concerning the limits of the model and required user inputs. The CAD model was based on the following documents:

- UMTRI-2013-13, *Seated Soldier Study: Posture and Body Shape in Vehicle Seats*, Final Report dated October 2013
- UMTRI-2014-26, *Development of Accommodation Models for Soldiers in Vehicles: Driver*, Final Report dated September 2014

- UMTRI Microsoft Excel spreadsheet, *Soldier Driver Accommodation Models 2017-05-03*
- UMTRI Microsoft Excel spreadsheet, *Seated Soldier Posture Prediction 2013-11-30*

10.1.2.3 BETA VERSION

The beta version of the FHP: Driver CAD model has not yet been applied to a program. The model, however, has been updated to include additional data provided from the *Seated Soldier Study* related to elbows, legs, and shins, and includes SME interpretation of MIL-STD-1472 and SAE J1050. This model will transition to a final release upon the completion of verification.

10.1.3 CONFIGURATION MANAGEMENT

The Advanced Concepts Team (ACT) will manage any changes to the FHP: Driver CAD accommodation model and upload the latest version.

The FHP: Driver CAD accommodation model is released in PDMLink at the following location:

Libraries > STANDARD CAD TEMPLATE LIBRARY, 19207 > Accommodation

The following top assemblies have been released:

12629792 TARDEC Fixed Heel Point Driver 19207_12629792

Questions related to the CAD model development and application should be sent to:

TARDEC Advanced Concepts Team
6501 E. 11 Mile Road
Bldg 200, RDTA-SIE-SE-AAC-TI-TICON
MS 207
Warren, MI 48397-5000

Gale L. Zielinski (Project Lead)
Office: (586) 282-5287
E-mail: gale.l.zielinski.civ@mail.mil

Frank J. Huston II (Model Developer)
Office: (586) 282-5657
E-mail: frank.j.huston.civ@mail.mil

10.2 APPENDIX B – REQUIREMENTS AND ACCEPTABILITY CRITERIA RESULTS

The requirements and acceptability criteria results for accommodation and posture prediction are shown below in Table 12 and Table 13, respectively. Metrics are noted as pass or fail. None of the metrics produced a failing result, so no corrective action plans are required.

Table 12: Accommodation Model Requirements Results

#	M&S Requirement	Acceptability Criteria	Metrics/Measures
1	Model allows for input of the Steering Wheel Point (SWP) in “X” (horizontal) and “Z” (vertical) coordinates.	1.1 Input parameter is available for steering wheel position in X	1.1 Representative (Pass) / Non-Representative (Fail)
		1.2 Input parameter is available for steering wheel position in Z	1.2 Representative (Pass) / Non-Representative (Fail)
2	Model allows for selection of seat hydration pack relief in the seat	2.1 Hydration pack relief selection of “yes” in model	2.1 Representative (Pass) / Non-Representative (Fail)
		2.2 Hydration pack relief selection of “no” in model	2.2 Representative (Pass) / Non-Representative (Fail)
3	Model allows for selection of either SAE J826 or ISO 5353 for the Human Accommodation Reference Point (HARP) measurement tool	3.1 HARP measurement tool selection of SAE J826 in model	3.1 Representative (Pass) / Non-Representative (Fail)
		3.2 HARP measurement tool selection of ISO 5353 in model	3.2 Representative (Pass) / Non-Representative (Fail)
4	Model allows for input of the population gender mix (e.g. 85% Male : 15% Female)	4.1 Fraction male input option in model	4.1 Representative (Pass) / Non-Representative (Fail)
5	Model allows for selection of ensemble as either PPE or ENC	5.1 Ensemble selection of PPE in model	5.1 Representative (Pass) / Non-Representative (Fail)
		5.2 Ensemble selection of ENC in model	5.2 Representative (Pass) / Non-Representative (Fail)
6	Model allows for a target population input (e.g. 90%)	6.1 Target accommodation input option in model	6.1 Representative (Pass) / Non-Representative (Fail)
7	Model predicts the Steering Wheel Preference Line	7.1 Model outputs a Steering Wheel Preference Line and SWP that adjusts with different inputs	7.1 Representative (Pass) / Non-Representative (Fail)
		7.2 TARDEC CAD model matches the UMTRI spreadsheet	7.2 Representative (Pass) / Non-Representative (Fail)
8	Model predicts a preferred steering wheel placement zone per guidance provided in the UMTRI paper <i>Preferred Steering Wheel Locations for Fixed-Heel-Point Driver Stations 2016-09-20</i> (fore/aft) and draft MIL-STD-1472H (side/side)	8.1 Model outputs a steering wheel placement zone that adjusts with different inputs	8.1 Representative (Pass) / Non-Representative (Fail)
		8.2 TARDEC CAD model matches the UMTRI spreadsheet and MIL-STD-1472H	8.2 Representative (Pass) / Non-Representative (Fail)
9	Model predicts the Accelerator Pedal Angle (APA)	9.1 Model outputs an APA that adjusts with different inputs	9.1 Representative (Pass) / Non-Representative (Fail)
		9.2 TARDEC CAD model matches the UMTRI spreadsheet	9.2 Representative (Pass) / Non-Representative (Fail)
10	Model predicts the expected distribution of driver-selected seat positions relative to the accelerator heel point (AHP) based on the SAE J826 and ISO 5353 Seat Index Point (SIP) seat measurement tools	10.1 Model outputs fore/aft and vertical seat track travel window for a given population and gender mix that adjusts with different inputs	10.1 Representative (Pass) / Non-Representative (Fail)
		10.2 TARDEC CAD model matches the UMTRI spreadsheet	10.2 Representative (Pass) / Non-Representative (Fail)

11	Model predicts the expected (dis)accommodation of driver-selected seat positions relative to the accelerator heel point (AHP) if the seat travel is censored	11.1 Model outputs (dis)accommodation value of a censored seat travel that adjusts with model inputs	11.1 Representative (Pass) / Non-Representative (Fail)
		11.2 TARDEC CAD model matches the UMTRI spreadsheet	11.2 Representative (Pass) / Non-Representative (Fail)
12	Model predicts the seat back angle adjustment range	12.1 Model outputs a range of seta back angles measured from vertical and adjusts with different inputs for the population	12.1 Representative (Pass) / Non-Representative (Fail)
		12.2 TARDEC CAD model matches the UMTRI spreadsheet	12.2 Representative (Pass) / Non-Representative (Fail)
13	Model predicts the dimensions and location of the eyellipse with respect to AHP and mean seat travel	13.1 Model outputs a left and right eyellipse for a given population and gender mix that adjusts with different inputs	13.1 Representative (Pass) / Non-Representative (Fail)
		13.2 TARDEC CAD model matches the UMTRI spreadsheet	13.2 Representative (Pass) / Non-Representative (Fail)
14	Model predicts the helmet contour boundary (helmet locations) with respect to the eye location and fitted to the eyellipse	14.1 Model outputs a helmet contour for the given population and gender mix that adjusts with the different inputs	14.1 Representative (Pass) / Non-Representative (Fail)
		14.2 TARDEC CAD model matches the UMTRI spreadsheet	14.2 Representative (Pass) / Non-Representative (Fail)
15	Model predicts the knee contour with leg and thigh segment angles based on location of resting drivers' knees in vehicle	15.1 Model outputs a knee ellipsoid for the given population and gender mix that adjusts with different inputs	15.1 Representative (Pass) / Non-Representative (Fail)
		15.2 TARDEC CAD model matches the UMTRI spreadsheet	15.2 Representative (Pass) / Non-Representative (Fail)
16	Model predicts torso contour with selected ensemble	16.1 Model predicts a torso contour with ensemble for the given population, gender mix, and ensemble configuration that adjusts with different inputs	16.1 Representative (Pass) / Non-Representative (Fail)
		16.2 TARDEC CAD model matches the UMTRI spreadsheet	16.2 Representative (Pass) / Non-Representative (Fail)
17	Model predicts elbow contours based on location of resting drivers' elbows in vehicle	17.1 Model outputs elbow contours for the given population and gender mix that adjusts with different inputs	17.1 Representative (Pass) / Non-Representative (Fail)
		17.2 TARDEC CAD model matches the UMTRI spreadsheet	17.2 Representative (Pass) / Non-Representative (Fail)
18	Model provides a clearance zone for the head (helmet) to roof line based on a back calculation from MIL-STD-1472G requirements	18.1 Model outputs a 2" clearance zone from the top of the helmet contour that adjusts with the different inputs	18.1 Representative (Pass) / Non-Representative (Fail)
19	Model provides a clearance zone for the knee, leg and thigh based on MIL-STD-1472H draft recommendations	19.1 Model outputs a 2" clearance zone from the top and front of the knee contour and the front of the leg segment and top of the thigh (in side-view) and adjusts with different inputs	19.1 Representative (Pass) / Non-Representative (Fail)
20	Model provides a clearance zone for the torso boundary, with selected	20.1 Model outputs a 2" clearance zone forward from the torso	20.1 Representative (Pass) / Non-Representative (Fail)

	ensemble, based on MIL-STD-1472H draft recommendations	boundary and adjusts and adjusts with the different inputs	
21	Model provides a lateral clearance zone for the elbow contours based on MIL-STD-1472H draft recommendations	21.1 Model output provides a 2” clearance zone laterally for the resting elbow contours	21.1 Representative (Pass) / Non-Representative (Fail)
22	Model provides direct field of view (primary, secondary, and tertiary zones) based on MIL-STD-1472G and SAE J1050	22.1 Model outputs primary vision zone that adjusts with model inputs	22.1 Representative (Pass) / Non-Representative (Fail)
		22.2 Model outputs secondary vision zone that adjusts with model inputs	22.2 Representative (Pass) / Non-Representative (Fail)
		22.3 Model outputs tertiary vision zone that adjusts with model inputs	22.3 Representative (Pass) / Non-Representative (Fail)
23	Model provides a ground intercept	23.1 Model outputs a line tangent to the bottom of the eyellipse to the ground and adjusts with different user inputs	23.1 Representative (Pass) / Non-Representative (Fail)

Table 13: Posture Prediction Model Results

#	M&S Requirement	Acceptability Criteria	Metrics/Measures
1	Model predicts the location of the hip with respect to the AHP	1.1 Model outputs the location of the hip with respect to the AHP that matches the UMTRI spreadsheet	1.1 Representative (Pass) / Non-Representative (Fail)
		1.2 The manikin hip joint center aligns with the hip point	1.2 Representative (Pass) / Non-Representative (Fail)
2	Model predicts the location of the eye with respect to the AHP	2.1 Model outputs the location of the eye with respect to the AHP that matches the UMTRI spreadsheet	2.1 Representative (Pass) / Non-Representative (Fail)
		2.2 The manikin eye aligns with the eye point	2.2 Representative (Pass) / Non-Representative (Fail)

10.2.1 TEST #1 – NUMERICAL RESULTS

Surrogate Steering Wheel				Helmet Boundary			
	UMTRI Value	TARDEC Value	Difference		UMTRI Value	TARDEC Value	Difference
STEERING_WHEEL_X	8.900	8.900	0.000	HELMET_CONTOUR_CENTROID_X	26.694	26.694	0.000
STEERING_WHEEL_Z	30.900	30.900	0.000	HELMET_CONTOUR_CENTROID_Y (+/-)	2.183	2.183	0.000
Steering Wheel Preference Line				Knee Boundary			
	UMTRI Value	TARDEC Value	Difference		UMTRI Value	TARDEC Value	Difference
STRG_WHL_FWD_X	14.297	14.297	0.000	KNEE_CONTOUR_WEIGHTED_CENT_X	6.754	6.754	0.000
STRG_WHL_FWD_Z	27.559	27.559	0.000	KNEE_CONTOUR_WEIGHTED_CENT_Y (+/-)	7.582	7.582	0.000
STRG_WHL_RWD_X	3.733	3.733	0.000	KNEE_CONTOUR_WEIGHTED_CENT_Z	20.939	20.939	0.000
STRG_WHL_RWD_Z	33.465	33.465	0.000	KNEE_CONTOUR_Y_AXIS_LENGTH	7.160	7.162	0.002
Steering Wheel Preference Zone				KNEE_CONTOUR_Y_AXIS_LENGTH	8.671	8.673	0.001
	UMTRI Value	TARDEC Value	Difference	KNEE_CONTOUR_Z_AXIS_LENGTH	6.851	6.851	0.000
STRG_WHL_ZONE_Z	1.515	1.516	0.001	KNEE_SHIN_ANGLE	19.273	19.273	0.000
STRG_WHL_ZONE_Y	N/A	1.000	N/A	KNEE_THIGH_ANGLE	6.124	6.124	0.000
Accelerator Plane Angle (APA)				Torso Boundary			
	UMTRI Value	TARDEC Value	Difference		UMTRI Value	TARDEC Value	Difference
ACCEL_PEDAL_PLANE_AVG	33.223	33.223	0.000	TORSO_WEIGHTED_REF_PT_PPE_X	19.358	19.357	0.001
Origin (X)	0.000	0.000	0.000	TORSO_WEIGHTED_REF_PT_PPE_Z	35.595	35.595	0.000
Origin (Z)	0.000	0.000	0.000	Elbow Boundary			
BOFRP (X)	-6.587	-6.587	0.000		UMTRI Value	TARDEC Value	Difference
BOFRP (Z)	4.314	4.314	0.000	ELBOW_WEIGHTED_CENT_X	26.589	26.589	0.000
Seat Track Travel Range				ELBOW_WEIGHTED_CENT_Y (+/-)	12.353	12.353	0.000
	UMTRI Value	TARDEC Value	Difference	ELBOW_WEIGHTED_CENT_Z	24.135	24.135	0.000
SEAT_POSITION_CTR_OF_TRAVEL_X	25.490	25.491	0.001	ELBOW_X_AXIS_LENGTH	7.303	7.305	0.002
SEAT_POSITION_CTR_OF_TRAVEL_Z	18.292	18.292	0.000	ELBOW_Y_AXIS_LENGTH	3.424	3.425	0.001
SEAT_POSITION_FORE_AFT_TRAVEL	6.535	6.535	0.001	ELBOW_Z_AXIS_LENGTH	5.665	5.668	0.003
SEAT_POSITION_VERTICAL_TRAVEL	3.222	3.223	0.001	Seat Back Angle			
Seat Back Angle					UMTRI Value	TARDEC Value	Difference
	UMTRI Value	TARDEC Value	Difference	SEAT_BACK_ANGLE_LOWER_QUANTILE	15.449	15.445	0.004
SEAT_BACK_ANGLE_LOWER_QUANTILE	15.449	15.445	0.004	SEAT_BACK_ANGLE_UPPER_QUANTILE	25.647	25.650	0.004
SEAT_BACK_ANGLE_UPPER_QUANTILE	25.647	25.650	0.004	Eyellipse			
Eyellipse					UMTRI Value	TARDEC Value	Difference
	UMTRI Value	TARDEC Value	Difference	EYELLIPSE_CENTROID_X	23.440	23.440	0.000
EYELLIPSE_CENTROID_X	23.440	23.440	0.000	EYELLIPSE_CENTROID_Y (+/-)	1.280	1.280	0.000
EYELLIPSE_CENTROID_Y (+/-)	1.280	1.280	0.000	EYELLIPSE_CENTROID_Z	44.649	44.649	0.000
EYELLIPSE_CENTROID_Z	44.649	44.649	0.000	EYELLIPSE_ANGLE_REL_X	18.600	18.600	0.000
EYELLIPSE_ANGLE_REL_X	18.600	18.600	0.000	EYELLIPSE_X_AXIS_LENGTH	6.370	6.373	0.003
EYELLIPSE_X_AXIS_LENGTH	6.370	6.373	0.003	EYELLIPSE_Y_AXIS_LENGTH	1.917	1.918	0.001
EYELLIPSE_Y_AXIS_LENGTH	1.917	1.918	0.001	EYELLIPSE_Z_AXIS_LENGTH	5.236	5.240	0.004
EYELLIPSE_Z_AXIS_LENGTH	5.236	5.240	0.004	Values in agreement			

TARDEC CAD values to agree with UMTRI spreadsheet values within
 ±0.100 inches
 ±0.100 degrees

Largest Observed Differences:
 0.004 inches
 0.004 degrees

Small Overall Female				Small Overall Male			
	UMTRI Value	TARDEC Value	Difference		UMTRI Value	TARDEC Value	Difference
POSTURE_DHM1_HIP_X	20.647	20.647	0.000	POSTURE_DHM2_HIP_X	22.769	22.769	0.000
POSTURE_DHM1_HIP_Z	18.060	18.060	0.000	POSTURE_DHM2_HIP_Z	18.169	18.169	0.000
POSTURE_DHM1_EYE_X	21.622	21.622	0.000	POSTURE_DHM2_EYE_X	22.873	22.873	0.000
POSTURE_DHM1_EYE_Z	40.128	40.128	0.000	POSTURE_DHM2_EYE_Z	41.895	41.895	0.000
Average Size Male				Widest Shoulders Male			
	UMTRI Value	TARDEC Value	Difference		UMTRI Value	TARDEC Value	Difference
POSTURE_DHM3_HIP_X	24.965	24.965	0.000	POSTURE_DHM4_HIP_X	25.973	25.973	0.000
POSTURE_DHM3_HIP_Z	18.169	18.169	0.000	POSTURE_DHM4_HIP_Z	18.157	18.157	0.000
POSTURE_DHM3_EYE_X	24.282	24.282	0.000	POSTURE_DHM4_EYE_X	24.938	24.938	0.000
POSTURE_DHM3_EYE_Z	44.119	44.119	0.000	POSTURE_DHM4_EYE_Z	45.397	45.397	0.000
Longest Torso Male				Longest Legs Male			
	UMTRI Value	TARDEC Value	Difference		UMTRI Value	TARDEC Value	Difference
POSTURE_DHM5_HIP_X	25.216	25.216	0.000	POSTURE_DHM6_HIP_X	27.489	27.489	0.000
POSTURE_DHM5_HIP_Z	18.151	18.151	0.000	POSTURE_DHM6_HIP_Z	18.222	18.222	0.000
POSTURE_DHM5_EYE_X	24.448	24.448	0.000	POSTURE_DHM6_EYE_X	25.858	25.858	0.000
POSTURE_DHM5_EYE_Z	46.398	46.398	0.000	POSTURE_DHM6_EYE_Z	44.618	44.618	0.000
Large Overall Male				Large Overall Male			
	UMTRI Value	TARDEC Value	Difference		UMTRI Value	TARDEC Value	Difference
POSTURE_DHM7_HIP_X	27.314	27.314	0.000	POSTURE_DHM7_HIP_X	27.314	27.314	0.000
POSTURE_DHM7_HIP_Z	18.320	18.320	0.000	POSTURE_DHM7_HIP_Z	18.320	18.320	0.000
POSTURE_DHM7_EYE_X	25.635	25.635	0.000	POSTURE_DHM7_EYE_X	25.635	25.635	0.000
POSTURE_DHM7_EYE_Z	46.357	46.357	0.000	POSTURE_DHM7_EYE_Z	46.357	46.357	0.000

TARDEC CAD values to agree with UMTRI spreadsheet values within
 ±0.100 inches
 ±0.100 degrees

Largest Observed Differences:
 0.000 inches

Values in agreement

10.2.2 TEST #2 – NUMERICAL RESULTS

Surrogate Steering Wheel			
STEERING_WHEEL_X	UMTRI Value	TARDEC Value	Difference
	14.800 in	14.800 in	0.000 in
STEERING_WHEEL_Z	30.900 in	30.900 in	0.000 in
Steering Wheel Preference Line			
STRG_WHL_FWD_X	UMTRI Value	TARDEC Value	Difference
	14.297 in	14.297 in	0.000 in
STRG_WHL_FWD_Z	27.559 in	27.559 in	0.000 in
STRG_WHL_RWD_X	3.733 in	3.733 in	0.000 in
STRG_WHL_RWD_Z	33.465 in	33.465 in	0.000 in
Steering Wheel Preference Zone			
STRG_WHL_ZONE_Z	UMTRI Value	TARDEC Value	Difference
	1.515 in	1.516 in	0.001 in
STRG_WHL_ZONE_Y	N/A	1.000 in	N/A
Accelerator Plane Angle (APA)			
ACCEL_PEDAL_PLANE_ANG	UMTRI Value	TARDEC Value	Difference
	33.223 deg	33.223 deg	0.000 deg
Origin (X)	0.000 in	0.000 in	0.000 in
Origin (Z)	0.000 in	0.000 in	0.000 in
BOFRP (X)	-6.587 in	-6.587 in	0.000 in
BOFRP (Z)	4.314 in	4.314 in	0.000 in
Seat Track Travel Range			
SEAT_POSITION_CTR_OF_TRAVEL_X	UMTRI Value	TARDEC Value	Difference
	28.363 in	28.394 in	0.001 in
SEAT_POSITION_CTR_OF_TRAVEL_Z	17.767 in	17.767 in	0.000 in
SEAT_POSITION_FORE_AFT_TRAVEL	6.535 in	6.535 in	0.001 in
SEAT_POSITION_VERTICAL_TRAVEL	3.223 in	3.223 in	0.001 in
Seat Back Angle			
SEAT_BACK_ANGLE_LOWER_QUANTILE	UMTRI Value	TARDEC Value	Difference
	16.872 deg	16.868 deg	0.004 deg
SEAT_BACK_ANGLE_UPPER_QUANTILE	27.070 deg	27.074 deg	0.004 deg
Eyellipse			
EYELLIPSE_CENTROID_X	UMTRI Value	TARDEC Value	Difference
	26.998 in	26.998 in	0.000 in
EYELLIPSE_CENTROID_Y (+/-)	1.280 in	1.280 in	0.000 in
EYELLIPSE_CENTROID_Z	44.124 in	44.124 in	0.000 in
EYELLIPSE_ANGLE_REL_X	18.600 deg	18.600 deg	0.000 deg
EYELLIPSE_X_AXIS_LENGTH	6.370 in	6.373 in	0.003 in
EYELLIPSE_Y_AXIS_LENGTH	1.917 in	1.918 in	0.001 in
EYELLIPSE_Z_AXIS_LENGTH	5.236 in	5.240 in	0.004 in

Helmet Boundary			
HELMET_CONTOUR_CENTROID_X	UMTRI Value	TARDEC Value	Difference
	30.242 in	30.242 in	0.000 in
HELMET_CONTOUR_CENTROID_Y (+/-)	2.185 in	2.185 in	0.000 in
HELMET_CONTOUR_CENTROID_Z	46.542 in	46.542 in	0.000 in
HELMET_CONTOUR_X_AXIS_LENGTH	17.045 in	17.048 in	0.003 in
HELMET_CONTOUR_Y_AXIS_LENGTH	9.515 in	9.517 in	0.001 in
HELMET_CONTOUR_Z_AXIS_LENGTH	13.292 in	13.296 in	0.004 in
Knee Boundary			
KNEE_CONTOUR_WEIGHTED_CENT_X	UMTRI Value	TARDEC Value	Difference
	9.627 in	9.627 in	0.000 in
KNEE_CONTOUR_WEIGHTED_CENT_Y (+/-)	7.085 in	7.085 in	0.000 in
KNEE_CONTOUR_WEIGHTED_CENT_Z	19.897 in	19.897 in	0.000 in
KNEE_CONTOUR_X_AXIS_LENGTH	7.587 in	7.589 in	0.002 in
KNEE_CONTOUR_Y_AXIS_LENGTH	8.674 in	8.673 in	0.001 in
KNEE_CONTOUR_Z_AXIS_LENGTH	6.250 in	6.350 in	0.000 in
KNEE_SHIN_ANGLE	28.445 deg	28.445 deg	0.000 deg
KNEE_THIGH_ANGLE	6.124 deg	6.124 deg	0.000 deg
Torso Boundary			
TORSO_WEIGHTED_REF_PT_PPE_X	UMTRI Value	TARDEC Value	Difference
	22.231 in	22.231 in	0.001 in
TORSO_WEIGHTED_REF_PT_PPE_Z	35.070 in	35.070 in	0.000 in
Elbow Boundary			
ELBOW_WEIGHTED_CENT_X	UMTRI Value	TARDEC Value	Difference
	29.463 in	29.463 in	0.000 in
ELBOW_WEIGHTED_CENT_Y (+/-)	12.353 in	12.353 in	0.000 in
ELBOW_WEIGHTED_CENT_Z	23.610 in	23.610 in	0.000 in
ELBOW_X_AXIS_LENGTH	7.303 in	7.305 in	0.002 in
ELBOW_Y_AXIS_LENGTH	3.424 in	3.425 in	0.001 in
ELBOW_Z_AXIS_LENGTH	5.655 in	5.668 in	0.003 in

TARDEC CAD values to agree with UMTRI spreadsheet values within
 ±0.100 inches
 ±0.100 degrees

Largest Observed Differences:
 0.004 inches
 0.004 degrees

Values in agreement

54

Small Overall Female			
POSTURE_DHM1_HIP_X	UMTRI Value	TARDEC Value	Difference
	23.709 in	23.709 in	0.000 in
POSTURE_DHM1_HIP_Z	17.617 in	17.617 in	0.000 in
POSTURE_DHM1_EYE_X	25.180 in	25.180 in	0.000 in
POSTURE_DHM1_EYE_Z	40.128 in	40.128 in	0.000 in
Small Overall Male			
POSTURE_DHM2_HIP_X	UMTRI Value	TARDEC Value	Difference
	25.831 in	25.831 in	0.000 in
POSTURE_DHM2_HIP_Z	17.727 in	17.727 in	0.000 in
POSTURE_DHM2_EYE_X	26.431 in	26.431 in	0.000 in
POSTURE_DHM2_EYE_Z	41.895 in	41.895 in	0.000 in
Average Size Male			
POSTURE_DHM3_HIP_X	UMTRI Value	TARDEC Value	Difference
	28.027 in	28.027 in	0.000 in
POSTURE_DHM3_HIP_Z	17.726 in	17.726 in	0.000 in
POSTURE_DHM3_EYE_X	27.839 in	27.839 in	0.000 in
POSTURE_DHM3_EYE_Z	44.119 in	44.119 in	0.000 in
Widest Shoulders Male			
POSTURE_DHM4_HIP_X	UMTRI Value	TARDEC Value	Difference
	29.035 in	29.035 in	0.000 in
POSTURE_DHM4_HIP_Z	17.715 in	17.715 in	0.000 in
POSTURE_DHM4_EYE_X	28.499 in	28.499 in	0.000 in
POSTURE_DHM4_EYE_Z	45.397 in	45.397 in	0.000 in
Longest Torso Male			
POSTURE_DHM5_HIP_X	UMTRI Value	TARDEC Value	Difference
	28.278 in	28.278 in	0.000 in
POSTURE_DHM5_HIP_Z	17.709 in	17.709 in	0.000 in
POSTURE_DHM5_EYE_X	28.005 in	28.005 in	0.000 in
POSTURE_DHM5_EYE_Z	46.398 in	46.398 in	0.000 in
Longest Legs Male			
POSTURE_DHM6_HIP_X	UMTRI Value	TARDEC Value	Difference
	30.531 in	30.531 in	0.000 in
POSTURE_DHM6_HIP_Z	17.780 in	17.780 in	0.000 in
POSTURE_DHM6_EYE_X	29.416 in	29.416 in	0.000 in
POSTURE_DHM6_EYE_Z	44.618 in	44.618 in	0.000 in
Large Overall Male			
POSTURE_DHM7_HIP_X	UMTRI Value	TARDEC Value	Difference
	30.376 in	30.376 in	0.000 in
POSTURE_DHM7_HIP_Z	17.877 in	17.877 in	0.000 in
POSTURE_DHM7_EYE_X	29.192 in	29.192 in	0.000 in
POSTURE_DHM7_EYE_Z	46.357 in	46.357 in	0.000 in

TARDEC CAD values to agree with UMTRI spreadsheet values within
 ±0.100 inches
 ±0.100 degrees

Largest Observed Differences:
 0.000 inches

Values in agreement

83

10.2.3 TEST #3 – NUMERICAL RESULTS

Surrogate Steering Wheel			
	UMTRI Value	TARDEC Value	Difference
STEERING_WHEEL_X	13.300 in	13.300 in	0.000 in
STEERING_WHEEL_Z	29.000 in	29.000 in	0.000 in
Steering Wheel Preference Line			
	UMTRI Value	TARDEC Value	Difference
STRG_WHL_FWD_X	14.297 in	14.297 in	0.000 in
STRG_WHL_FWD_Z	27.559 in	27.559 in	0.000 in
STRG_WHL_RWD_X	3.733 in	3.733 in	0.000 in
STRG_WHL_RWD_Z	33.465 in	33.465 in	0.000 in
Steering Wheel Preference Zone			
	UMTRI Value	TARDEC Value	Difference
STRG_WHL_ZONE_Z	1.515 in	1.516 in	0.001 in
STRG_WHL_ZONE_Y	N/A	1.000 in	N/A
Accelerator Plane Angle (APA)			
	UMTRI Value	TARDEC Value	Difference
ACCEL_PEDAL_PLANE_ANG	41.438 deg	41.438 deg	0.000 deg
Origin (X)	0.000 in	0.000 in	0.000 in
Origin (Z)	0.000 in	0.000 in	0.000 in
BOFRP (X)	-5.903 in	-5.903 in	0.000 in
BOFRP (Z)	5.211 in	5.211 in	0.000 in
Seat Track Travel Range			
	UMTRI Value	TARDEC Value	Difference
SEAT_POSITION_CTR_OF_TRAVEL_X	28.617 in	28.619 in	0.001 in
SEAT_POSITION_CTR_OF_TRAVEL_Z	16.146 in	16.146 in	0.000 in
SEAT_POSITION_FORE_AFT_TRAVEL	6.535 in	6.535 in	0.001 in
SEAT_POSITION_VERTICAL_TRAVEL	3.223 in	3.223 in	0.001 in
Seat Back Angle			
	UMTRI Value	TARDEC Value	Difference
SEAT_BACK_ANGLE_LOWER_QUANTILE	16.510 deg	16.507 deg	0.004 deg
SEAT_BACK_ANGLE_UPPER_QUANTILE	26.708 deg	26.712 deg	0.004 deg
Eyellipse			
	UMTRI Value	TARDEC Value	Difference
EYELLIPSE_CENTROID_X	26.716 in	26.716 in	0.000 in
EYELLIPSE_CENTROID_Y (+/-)	1.280 in	1.280 in	0.000 in
EYELLIPSE_CENTROID_Z	42.504 in	42.504 in	0.000 in
EYELLIPSE_ANGLE_REL_X	18.600 deg	18.600 deg	0.000 deg
EYELLIPSE_X_AXIS_LENGTH	6.370 in	6.373 in	0.003 in
EYELLIPSE_Y_AXIS_LENGTH	1.917 in	1.918 in	0.001 in
EYELLIPSE_Z_AXIS_LENGTH	5.236 in	5.240 in	0.004 in

Helmet Boundary			
	UMTRI Value	TARDEC Value	Difference
HELMET_CONTOUR_CENTROID_X	29.960 in	29.960 in	0.000 in
HELMET_CONTOUR_CENTROID_Y (+/-)	2.185 in	2.185 in	0.000 in
HELMET_CONTOUR_CENTROID_Z	44.921 in	44.921 in	0.000 in
HELMET_CONTOUR_X_AXIS_LENGTH	17.048 in	17.048 in	0.003 in
HELMET_CONTOUR_Y_AXIS_LENGTH	9.515 in	9.517 in	0.001 in
HELMET_CONTOUR_Z_AXIS_LENGTH	13.292 in	13.296 in	0.004 in
Knee Boundary			
	UMTRI Value	TARDEC Value	Difference
KNEE_CONTOUR_WEIGHTED_CENT_X	10.112 in	10.112 in	0.000 in
KNEE_CONTOUR_WEIGHTED_CENT_Y (+/-)	7.331 in	7.331 in	0.000 in
KNEE_CONTOUR_WEIGHTED_CENT_Z	19.772 in	19.772 in	0.000 in
KNEE_CONTOUR_X_AXIS_LENGTH	7.611 in	7.613 in	0.002 in
KNEE_CONTOUR_Y_AXIS_LENGTH	8.671 in	8.673 in	0.001 in
KNEE_CONTOUR_Z_AXIS_LENGTH	6.317 in	6.317 in	0.000 in
KNEE_SHIN_ANGLE	29.013 deg	29.013 deg	0.000 deg
KNEE_THIGH_ANGLE	10.322 deg	10.322 deg	0.000 deg
Torso Boundary			
	UMTRI Value	TARDEC Value	Difference
TORSO_WEIGHTED_REF_PT_PPE_X	22.289 in	22.288 in	0.001 in
TORSO_WEIGHTED_REF_PT_PPE_Z	33.449 in	33.449 in	0.000 in
Elbow Boundary			
	UMTRI Value	TARDEC Value	Difference
ELBOW_WEIGHTED_CENT_X	29.717 in	29.717 in	0.000 in
ELBOW_WEIGHTED_CENT_Y (+/-)	12.353 in	12.353 in	0.000 in
ELBOW_WEIGHTED_CENT_Z	21.989 in	21.989 in	0.000 in
ELBOW_X_AXIS_LENGTH	7.303 in	7.305 in	0.002 in
ELBOW_Y_AXIS_LENGTH	3.424 in	3.425 in	0.001 in
ELBOW_Z_AXIS_LENGTH	5.655 in	5.658 in	0.003 in

TARDEC CAD values to agree with UMTRI spreadsheet values within
 ±0.100 inches
 ±0.100 degrees

Largest Observed Differences:
 0.004 inches
 0.004 degrees

Values in agreement

92

Small Overall Female			
	UMTRI Value	TARDEC Value	Difference
POSTURE_DHM1_HIP_X	23.660 in	23.660 in	0.000 in
POSTURE_DHM1_HIP_Z	15.879 in	15.879 in	0.000 in
POSTURE_DHM1_EYE_X	24.940 in	24.940 in	0.000 in
POSTURE_DHM1_EYE_Z	38.171 in	38.171 in	0.000 in
Small Overall Male			
	UMTRI Value	TARDEC Value	Difference
POSTURE_DHM2_HIP_X	25.782 in	25.782 in	0.000 in
POSTURE_DHM2_HIP_Z	15.989 in	15.989 in	0.000 in
POSTURE_DHM2_EYE_X	26.191 in	26.191 in	0.000 in
POSTURE_DHM2_EYE_Z	39.938 in	39.938 in	0.000 in
Average Size Male			
	UMTRI Value	TARDEC Value	Difference
POSTURE_DHM3_HIP_X	27.977 in	27.977 in	0.000 in
POSTURE_DHM3_HIP_Z	15.988 in	15.988 in	0.000 in
POSTURE_DHM3_EYE_X	27.599 in	27.599 in	0.000 in
POSTURE_DHM3_EYE_Z	42.162 in	42.162 in	0.000 in
Widest Shoulders Male			
	UMTRI Value	TARDEC Value	Difference
POSTURE_DHM4_HIP_X	28.985 in	28.986 in	0.000 in
POSTURE_DHM4_HIP_Z	15.977 in	15.977 in	0.000 in
POSTURE_DHM4_EYE_X	28.259 in	28.256 in	0.000 in
POSTURE_DHM4_EYE_Z	43.440 in	43.440 in	0.000 in
Longest Torso Male			
	UMTRI Value	TARDEC Value	Difference
POSTURE_DHM5_HIP_X	28.229 in	28.229 in	0.000 in
POSTURE_DHM5_HIP_Z	15.971 in	15.971 in	0.000 in
POSTURE_DHM5_EYE_X	27.765 in	27.765 in	0.000 in
POSTURE_DHM5_EYE_Z	44.441 in	44.441 in	0.000 in
Longest Legs Male			
	UMTRI Value	TARDEC Value	Difference
POSTURE_DHM6_HIP_X	30.501 in	30.506 in	0.000 in
POSTURE_DHM6_HIP_Z	16.042 in	16.042 in	0.000 in
POSTURE_DHM6_EYE_X	29.176 in	29.176 in	0.000 in
POSTURE_DHM6_EYE_Z	42.661 in	42.661 in	0.000 in
Large Overall Male			
	UMTRI Value	TARDEC Value	Difference
POSTURE_DHM7_HIP_X	30.327 in	30.327 in	0.000 in
POSTURE_DHM7_HIP_Z	16.139 in	16.139 in	0.000 in
POSTURE_DHM7_EYE_X	28.952 in	28.952 in	0.000 in
POSTURE_DHM7_EYE_Z	44.400 in	44.400 in	0.000 in

TARDEC CAD values to agree with UMTRI spreadsheet values within
 ±0.100 inches
 ±0.100 degrees

Largest Observed Differences:
 0.000 inches

Values in agreement

121

10.2.4 TEST #4 – NUMERICAL RESULTS

Surrogate Steering Wheel			
	UMTRI Value	TARDEC Value	Difference
STEERING_WHEEL_X	11.800 in	11.800 in	0.000 in
STEERING_WHEEL_Z	29.000 in	29.000 in	0.000 in
Steering Wheel Preference Line			
	UMTRI Value	TARDEC Value	Difference
STRG_WHL_FWD_X	14.297 in	14.297 in	0.000 in
STRG_WHL_FWD_Z	27.559 in	27.559 in	0.000 in
STRG_WHL_RWD_X	3.733 in	3.733 in	0.000 in
STRG_WHL_RWD_Z	33.465 in	33.465 in	0.000 in
Steering Wheel Preference Zone			
	UMTRI Value	TARDEC Value	Difference
STRG_WHL_ZONE_Z	1.515 in	1.516 in	0.001 in
STRG_WHL_ZONE_Y	N/A	1.000 in	N/A
Accelerator Plane Angle (APA)			
	UMTRI Value	TARDEC Value	Difference
ACCEL_PEDAL_PLANE_ANG	41.438 deg	41.438 deg	0.000 deg
Origin (X)	0.000 in	0.000 in	0.000 in
Origin (Z)	0.000 in	0.000 in	0.000 in
BOFRP (X)	-5.903 in	-5.903 in	0.000 in
BOFRP (Z)	5.211 in	5.211 in	0.000 in
Seat Track Travel Range			
	UMTRI Value	TARDEC Value	Difference
SEAT_POSITION_CTR_OF_TRAVEL_X	27.690 in	27.691 in	0.001 in
SEAT_POSITION_CTR_OF_TRAVEL_Z	16.279 in	16.279 in	0.000 in
SEAT_POSITION_FORE_AFT_TRAVEL	6.535 in	6.535 in	0.001 in
SEAT_POSITION_VERTICAL_TRAVEL	3.223 in	3.223 in	0.001 in
Seat Back Angle			
	UMTRI Value	TARDEC Value	Difference
SEAT_BACK_ANGLE_LOWER_QUANTILE	16.148 deg	16.145 deg	0.004 deg
SEAT_BACK_ANGLE_UPPER_QUANTILE	26.346 deg	26.350 deg	0.004 deg
Eyellipse			
	UMTRI Value	TARDEC Value	Difference
EYELLIPSE_CENTROID_X	25.812 in	25.812 in	0.000 in
EYELLIPSE_CENTROID_Y (+/-)	1.280 in	1.280 in	0.000 in
EYELLIPSE_CENTROID_Z	42.637 in	42.637 in	0.000 in
EYELLIPSE_ANGLE_REL_X	18.600 deg	18.600 deg	0.000 deg
EYELLIPSE_X_AXIS_LENGTH	6.370 in	6.373 in	0.003 in
EYELLIPSE_Y_AXIS_LENGTH	1.917 in	1.918 in	0.001 in
EYELLIPSE_Z_AXIS_LENGTH	5.236 in	5.240 in	0.004 in

Helmet Boundary			
	UMTRI Value	TARDEC Value	Difference
HELMET_CONTOUR_CENTROID_X	29.056 in	29.056 in	0.000 in
HELMET_CONTOUR_CENTROID_Y (+/-)	2.185 in	2.185 in	0.000 in
HELMET_CONTOUR_CENTROID_Z	45.054 in	45.055 in	0.000 in
HELMET_CONTOUR_X_AXIS_LENGTH	17.048 in	17.048 in	0.003 in
HELMET_CONTOUR_Y_AXIS_LENGTH	9.515 in	9.517 in	0.001 in
HELMET_CONTOUR_Z_AXIS_LENGTH	13.292 in	13.296 in	0.004 in
Knee Boundary			
	UMTRI Value	TARDEC Value	Difference
KNEE_CONTOUR_WEIGHTED_CENT_X	9.382 in	9.382 in	0.000 in
KNEE_CONTOUR_WEIGHTED_CENT_Y (+/-)	7.458 in	7.458 in	0.000 in
KNEE_CONTOUR_WEIGHTED_CENT_Z	20.033 in	20.033 in	0.000 in
KNEE_CONTOUR_X_AXIS_LENGTH	7.511 in	7.513 in	0.002 in
KNEE_CONTOUR_Y_AXIS_LENGTH	8.671 in	8.673 in	0.001 in
KNEE_CONTOUR_Z_AXIS_LENGTH	6.452 in	6.452 in	0.000 in
KNEE_SHIN_ANGLE	26.682 deg	26.682 deg	0.000 deg
KNEE_THIGH_ANGLE	10.322 deg	10.322 deg	0.000 deg
Torso Boundary			
	UMTRI Value	TARDEC Value	Difference
TORSO_WEIGHTED_REF_PT_PPE_X	21.559 in	21.558 in	0.001 in
TORSO_WEIGHTED_REF_PT_PPE_Z	33.583 in	33.583 in	0.000 in
Elbow Boundary			
	UMTRI Value	TARDEC Value	Difference
ELBOW_WEIGHTED_CENT_X	28.790 in	28.790 in	0.000 in
ELBOW_WEIGHTED_CENT_Y (+/-)	12.353 in	12.353 in	0.000 in
ELBOW_WEIGHTED_CENT_Z	22.123 in	22.123 in	0.000 in
ELBOW_X_AXIS_LENGTH	7.303 in	7.305 in	0.002 in
ELBOW_Y_AXIS_LENGTH	3.424 in	3.425 in	0.001 in
ELBOW_Z_AXIS_LENGTH	5.655 in	5.668 in	0.003 in

TARDEC CAD values to agree with UMTRI spreadsheet values within
 ±0.100 inches
 ±0.100 degrees

Largest Observed Differences:
 0.004 inches
 0.004 degrees

Values in agreement

130

Small Overall Female			
	UMTRI Value	TARDEC Value	Difference
POSTURE_DHM1_HIP_X	22.881 in	22.881 in	0.000 in
POSTURE_DHM1_HIP_Z	15.992 in	15.992 in	0.000 in
POSTURE_DHM1_EYE_X	24.036 in	24.036 in	0.000 in
POSTURE_DHM1_EYE_Z	38.171 in	38.171 in	0.000 in
Small Overall Male			
	UMTRI Value	TARDEC Value	Difference
POSTURE_DHM2_HIP_X	25.003 in	25.003 in	0.000 in
POSTURE_DHM2_HIP_Z	16.102 in	16.102 in	0.000 in
POSTURE_DHM2_EYE_X	25.286 in	25.286 in	0.000 in
POSTURE_DHM2_EYE_Z	39.938 in	39.938 in	0.000 in
Average Size Male			
	UMTRI Value	TARDEC Value	Difference
POSTURE_DHM3_HIP_X	27.199 in	27.199 in	0.000 in
POSTURE_DHM3_HIP_Z	16.101 in	16.101 in	0.000 in
POSTURE_DHM3_EYE_X	26.695 in	26.695 in	0.000 in
POSTURE_DHM3_EYE_Z	42.162 in	42.162 in	0.000 in
Widest Shoulders Male			
	UMTRI Value	TARDEC Value	Difference
POSTURE_DHM4_HIP_X	28.207 in	28.207 in	0.000 in
POSTURE_DHM4_HIP_Z	16.090 in	16.090 in	0.000 in
POSTURE_DHM4_EYE_X	27.351 in	27.351 in	0.000 in
POSTURE_DHM4_EYE_Z	43.440 in	43.440 in	0.000 in
Longest Torso Male			
	UMTRI Value	TARDEC Value	Difference
POSTURE_DHM5_HIP_X	27.451 in	27.450 in	0.000 in
POSTURE_DHM5_HIP_Z	16.084 in	16.084 in	0.000 in
POSTURE_DHM5_EYE_X	26.851 in	26.851 in	0.000 in
POSTURE_DHM5_EYE_Z	44.441 in	44.441 in	0.000 in
Longest Legs Male			
	UMTRI Value	TARDEC Value	Difference
POSTURE_DHM6_HIP_X	29.723 in	29.723 in	0.000 in
POSTURE_DHM6_HIP_Z	16.155 in	16.155 in	0.000 in
POSTURE_DHM6_EYE_X	28.271 in	28.272 in	0.000 in
POSTURE_DHM6_EYE_Z	42.661 in	42.661 in	0.000 in
Large Overall Male			
	UMTRI Value	TARDEC Value	Difference
POSTURE_DHM7_HIP_X	29.548 in	29.548 in	0.000 in
POSTURE_DHM7_HIP_Z	16.252 in	16.252 in	0.000 in
POSTURE_DHM7_EYE_X	28.048 in	28.048 in	0.000 in
POSTURE_DHM7_EYE_Z	44.400 in	44.400 in	0.000 in

TARDEC CAD values to agree with UMTRI spreadsheet values within
 ±0.100 inches
 ±0.100 degrees

Largest Observed Differences:
 0.000 inches

Values in agreement

159

10.2.5 TEST #5 – NUMERICAL RESULTS

Surrogate Steering Wheel			
	UMTRI Value	TARDEC Value	Difference
STEERING_WHEEL_X	17.700 in	17.700 in	0.000 in
STEERING_WHEEL_Z	27.000 in	27.000 in	0.000 in
Steering Wheel Preference Line			
	UMTRI Value	TARDEC Value	Difference
STRG_WHL_FWD_X	14.297 in	14.297 in	0.000 in
STRG_WHL_FWD_Z	27.559 in	27.559 in	0.000 in
STRG_WHL_RWD_X	3.733 in	3.733 in	0.000 in
STRG_WHL_RWD_Z	33.465 in	33.465 in	0.000 in
Steering Wheel Preference Zone			
	UMTRI Value	TARDEC Value	Difference
STRG_WHL_ZONE_Z	1.515 in	1.516 in	0.001 in
STRG_WHL_ZONE_Y	N/A	1.000 in	N/A
Accelerator Plane Angle (APA)			
	UMTRI Value	TARDEC Value	Difference
ACCEL_PEDAL_PLANE_ANG	49.214 deg	49.214 deg	0.000 deg
Origin (X)	0.000 in	0.000 in	0.000 in
Origin (Z)	0.000 in	0.000 in	0.000 in
BOFRP (X)	-5.144 in	-5.144 in	0.000 in
BOFRP (Z)	5.962 in	5.962 in	0.000 in
Seat Track Travel Range			
	UMTRI Value	TARDEC Value	Difference
SEAT_POSITION_CTR_OF_TRAVEL_X	31.393 in	31.394 in	0.001 in
SEAT_POSITION_CTR_OF_TRAVEL_Z	13.908 in	13.908 in	0.000 in
SEAT_POSITION_FORE_AFT_TRAVEL	6.535 in	6.535 in	0.001 in
SEAT_POSITION_VERTICAL_TRAVEL	3.222 in	3.223 in	0.001 in
Seat Back Angle			
	UMTRI Value	TARDEC Value	Difference
SEAT_BACK_ANGLE_LOWER_QUANTILE	17.572 deg	17.568 deg	0.004 deg
SEAT_BACK_ANGLE_UPPER_QUANTILE	27.770 deg	27.774 deg	0.004 deg
Eyellipse			
	UMTRI Value	TARDEC Value	Difference
EYELLIPSE_CENTROID_X	30.025 in	30.025 in	0.000 in
EYELLIPSE_CENTROID_Y (+/-)	1.280 in	1.280 in	0.000 in
EYELLIPSE_CENTROID_Z	40.266 in	40.266 in	0.000 in
EYELLIPSE_ANGLE_REL_X	18.600 deg	18.600 deg	0.000 deg
EYELLIPSE_X_AXIS_LENGTH	6.370 in	6.373 in	0.003 in
EYELLIPSE_Y_AXIS_LENGTH	1.917 in	1.918 in	0.001 in
EYELLIPSE_Z_AXIS_LENGTH	5.236 in	5.240 in	0.004 in

Helmet Boundary			
	UMTRI Value	TARDEC Value	Difference
HELMET_CONTOUR_CENTROID_X	33.269 in	33.269 in	0.000 in
HELMET_CONTOUR_CENTROID_Y (+/-)	2.189 in	2.189 in	0.000 in
HELMET_CONTOUR_CENTROID_Z	42.683 in	42.683 in	0.000 in
HELMET_CONTOUR_X_AXIS_LENGTH	17.048 in	17.048 in	0.003 in
HELMET_CONTOUR_Y_AXIS_LENGTH	9.515 in	9.517 in	0.001 in
HELMET_CONTOUR_Z_AXIS_LENGTH	13.292 in	13.296 in	0.004 in
Knee Boundary			
	UMTRI Value	TARDEC Value	Difference
KNEE_CONTOUR_WEIGHTED_CENT_X	13.535 in	13.535 in	0.000 in
KNEE_CONTOUR_WEIGHTED_CENT_Y (+/-)	7.087 in	7.087 in	0.000 in
KNEE_CONTOUR_WEIGHTED_CENT_Z	18.619 in	18.619 in	0.000 in
KNEE_CONTOUR_X_AXIS_LENGTH	7.969 in	7.971 in	0.002 in
KNEE_CONTOUR_Y_AXIS_LENGTH	8.671 in	8.673 in	0.001 in
KNEE_CONTOUR_Z_AXIS_LENGTH	5.704 in	5.704 in	0.000 in
KNEE_SHIN_ANGLE	38.906 deg	38.906 deg	0.000 deg
KNEE_THIGH_ANGLE	14.742 deg	14.742 deg	0.000 deg
Torso Boundary			
	UMTRI Value	TARDEC Value	Difference
TORSO_WEIGHTED_REF_PT_PPE_X	25.261 in	25.260 in	0.001 in
TORSO_WEIGHTED_REF_PT_PPE_Z	31.211 in	31.211 in	0.000 in
Elbow Boundary			
	UMTRI Value	TARDEC Value	Difference
ELBOW_WEIGHTED_CENT_X	32.493 in	32.493 in	0.000 in
ELBOW_WEIGHTED_CENT_Y (+/-)	12.353 in	12.353 in	0.000 in
ELBOW_WEIGHTED_CENT_Z	19.751 in	19.751 in	0.000 in
ELBOW_X_AXIS_LENGTH	7.303 in	7.305 in	0.002 in
ELBOW_Y_AXIS_LENGTH	3.424 in	3.425 in	0.001 in
ELBOW_Z_AXIS_LENGTH	5.655 in	5.668 in	0.003 in

TARDEC CAD values to agree with UMTRI spreadsheet values within
 ±0.100 inches
 ±0.100 degrees

Largest Observed Differences:
 0.004 inches
 0.004 degrees

Values in agreement

168

Small Overall Female			
	UMTRI Value	TARDEC Value	Difference
POSTURE_DHM1_HIP_X	26.711 in	26.711 in	0.000 in
POSTURE_DHM1_HIP_Z	13.602 in	13.602 in	0.000 in
POSTURE_DHM1_EYE_X	28.293 in	28.293 in	0.000 in
POSTURE_DHM1_EYE_Z	36.111 in	36.111 in	0.000 in
Small Overall Male			
	UMTRI Value	TARDEC Value	Difference
POSTURE_DHM2_HIP_X	28.833 in	28.833 in	0.000 in
POSTURE_DHM2_HIP_Z	13.712 in	13.712 in	0.000 in
POSTURE_DHM2_EYE_X	29.543 in	29.543 in	0.000 in
POSTURE_DHM2_EYE_Z	37.878 in	37.878 in	0.000 in
Average Size Male			
	UMTRI Value	TARDEC Value	Difference
POSTURE_DHM3_HIP_X	31.029 in	31.028 in	0.000 in
POSTURE_DHM3_HIP_Z	13.711 in	13.711 in	0.000 in
POSTURE_DHM3_EYE_X	30.952 in	30.952 in	0.000 in
POSTURE_DHM3_EYE_Z	40.102 in	40.102 in	0.000 in
Widest Shoulders Male			
	UMTRI Value	TARDEC Value	Difference
POSTURE_DHM4_HIP_X	32.036 in	32.037 in	0.000 in
POSTURE_DHM4_HIP_Z	13.700 in	13.700 in	0.000 in
POSTURE_DHM4_EYE_X	31.608 in	31.608 in	0.000 in
POSTURE_DHM4_EYE_Z	41.380 in	41.380 in	0.000 in
Longest Torso Male			
	UMTRI Value	TARDEC Value	Difference
POSTURE_DHM5_HIP_X	31.280 in	31.280 in	0.000 in
POSTURE_DHM5_HIP_Z	13.694 in	13.694 in	0.000 in
POSTURE_DHM5_EYE_X	31.118 in	31.118 in	0.000 in
POSTURE_DHM5_EYE_Z	42.381 in	42.381 in	0.000 in
Longest Legs Male			
	UMTRI Value	TARDEC Value	Difference
POSTURE_DHM6_HIP_X	33.523 in	33.523 in	0.000 in
POSTURE_DHM6_HIP_Z	13.765 in	13.765 in	0.000 in
POSTURE_DHM6_EYE_X	32.529 in	32.529 in	0.000 in
POSTURE_DHM6_EYE_Z	40.601 in	40.601 in	0.000 in
Large Overall Male			
	UMTRI Value	TARDEC Value	Difference
POSTURE_DHM7_HIP_X	33.378 in	33.378 in	0.000 in
POSTURE_DHM7_HIP_Z	13.862 in	13.862 in	0.000 in
POSTURE_DHM7_EYE_X	32.305 in	32.305 in	0.000 in
POSTURE_DHM7_EYE_Z	42.340 in	42.340 in	0.000 in

TARDEC CAD values to agree with UMTRI spreadsheet values within
 ±0.100 inches
 ±0.100 degrees

Largest Observed Differences:
 0.000 inches

Values in agreement

197

10.2.6 TEST #6 – NUMERICAL RESULTS

Surrogate Steering Wheel			
	UMTRI Value	TARDEC Value	Difference
STEERING_WHEEL_X	13.300 in	13.300 in	0.000 in
STEERING_WHEEL_Z	29.000 in	29.000 in	0.000 in
Steering Wheel Preference Line			
	UMTRI Value	TARDEC Value	Difference
STRG_WHL_FWD_X	14.297 in	14.297 in	0.000 in
STRG_WHL_FWD_Z	27.559 in	27.559 in	0.000 in
STRG_WHL_RWD_X	3.733 in	3.733 in	0.000 in
STRG_WHL_RWD_Z	33.465 in	33.465 in	0.000 in
Steering Wheel Preference Zone			
	UMTRI Value	TARDEC Value	Difference
STRG_WHL_ZONE_Z	1.515 in	1.516 in	0.001 in
STRG_WHL_ZONE_Y	N/A	1.000 in	N/A
Accelerator Plane Angle (APA)			
	UMTRI Value	TARDEC Value	Difference
ACCEL_PEDAL_PLANE_ANG	41.438 deg	41.438 deg	0.000 deg
Origin (X)	0.000 in	0.000 in	0.000 in
Origin (Z)	0.000 in	0.000 in	0.000 in
BOFRP (X)	-5.903 in	-5.903 in	0.000 in
BOFRP (Z)	-5.211 in	-5.211 in	0.000 in
Seat Track Travel Range			
	UMTRI Value	TARDEC Value	Difference
SEAT_POSITION_CTR_OF_TRAVEL_X	27.602 in	27.603 in	0.001 in
SEAT_POSITION_CTR_OF_TRAVEL_Z	16.244 in	16.244 in	0.000 in
SEAT_POSITION_FORE_AFT_TRAVEL	6.535 in	6.535 in	0.001 in
SEAT_POSITION_VERTICAL_TRAVEL	3.223 in	3.223 in	0.001 in
Seat Back Angle			
	UMTRI Value	TARDEC Value	Difference
SEAT_BACK_ANGLE_LOWER_QUANTILE	16.510 deg	16.507 deg	0.004 deg
SEAT_BACK_ANGLE_UPPER_QUANTILE	26.708 deg	26.712 deg	0.004 deg
Eyellipse			
	UMTRI Value	TARDEC Value	Difference
EYELLIPSE_GENTROID_X	28.114 in	28.114 in	0.000 in
EYELLIPSE_GENTROID_Y (+/-)	1.280 in	1.280 in	0.000 in
EYELLIPSE_GENTROID_Z	42.090 in	42.090 in	0.000 in
EYELLIPSE_ANGLE_REL_X	18.600 deg	18.600 deg	0.000 deg
EYELLIPSE_X_AXIS_LENGTH	6.570 in	6.573 in	0.003 in
EYELLIPSE_Y_AXIS_LENGTH	1.917 in	1.918 in	0.001 in
EYELLIPSE_Z_AXIS_LENGTH	5.236 in	5.240 in	0.004 in

Helmet Boundary			
The ACU ensemble does not include a helmet			
Knee Boundary			
	UMTRI Value	TARDEC Value	Difference
KNEE_CONTOUR_WEIGHTED_CENT_X	10.199 in	10.199 in	0.000 in
KNEE_CONTOUR_WEIGHTED_CENT_Y (+/-)	7.331 in	7.331 in	0.000 in
KNEE_CONTOUR_WEIGHTED_CENT_Z	19.772 in	19.772 in	0.000 in
KNEE_CONTOUR_X_AXIS_LENGTH	7.611 in	7.613 in	0.002 in
KNEE_CONTOUR_Y_AXIS_LENGTH	8.671 in	8.673 in	0.001 in
KNEE_CONTOUR_Z_AXIS_LENGTH	6.317 in	6.317 in	0.000 in
KNEE_SHIN_ANGLE	29.013 deg	29.013 deg	0.000 deg
KNEE_THIGH_ANGLE	10.322 deg	10.322 deg	0.000 deg
Torso Boundary			
A torso boundary is not provided when the ACU ensemble is chosen			
Elbow Boundary			
	UMTRI Value	TARDEC Value	Difference
ELBOW_WEIGHTED_CENT_X	29.627 in	29.627 in	0.000 in
ELBOW_WEIGHTED_CENT_Y (+/-)	11.479 in	11.479 in	0.000 in
ELBOW_WEIGHTED_CENT_Z	21.304 in	21.304 in	0.000 in
ELBOW_X_AXIS_LENGTH	7.303 in	7.305 in	0.002 in
ELBOW_Y_AXIS_LENGTH	3.424 in	3.425 in	0.001 in
ELBOW_Z_AXIS_LENGTH	5.663 in	5.668 in	0.003 in

TARDEC CAD values to agree with UMTRI spreadsheet values within
 ±0.100 inches
 ±0.100 degrees

Largest Observed Differences:
 0.004 inches
 0.004 degrees

Values in agreement

206

Small Overall Female			
	UMTRI Value	TARDEC Value	Difference
POSTURE_DH11_HIP_X	23.660 in	23.660 in	0.000 in
POSTURE_DH11_HIP_Z	15.879 in	15.879 in	0.000 in
POSTURE_DH11_EYE_X	26.357 in	26.357 in	0.000 in
POSTURE_DH11_EYE_Z	38.171 in	38.171 in	0.000 in
Small Overall Male			
	UMTRI Value	TARDEC Value	Difference
POSTURE_DH12_HIP_X	25.782 in	25.782 in	0.000 in
POSTURE_DH12_HIP_Z	15.989 in	15.989 in	0.000 in
POSTURE_DH12_EYE_X	27.608 in	27.608 in	0.000 in
POSTURE_DH12_EYE_Z	39.938 in	39.938 in	0.000 in
Average Size Male			
	UMTRI Value	TARDEC Value	Difference
POSTURE_DH13_HIP_X	27.977 in	27.977 in	0.000 in
POSTURE_DH13_HIP_Z	15.968 in	15.968 in	0.000 in
POSTURE_DH13_EYE_X	29.017 in	29.017 in	0.000 in
POSTURE_DH13_EYE_Z	42.162 in	42.162 in	0.000 in
Widest Shoulders Male			
	UMTRI Value	TARDEC Value	Difference
POSTURE_DH14_HIP_X	28.985 in	28.985 in	0.000 in
POSTURE_DH14_HIP_Z	15.977 in	15.977 in	0.000 in
POSTURE_DH14_EYE_X	29.673 in	29.673 in	0.000 in
POSTURE_DH14_EYE_Z	43.440 in	43.440 in	0.000 in
Longest Torso Male			
	UMTRI Value	TARDEC Value	Difference
POSTURE_DH15_HIP_X	28.229 in	28.229 in	0.000 in
POSTURE_DH15_HIP_Z	15.971 in	15.971 in	0.000 in
POSTURE_DH15_EYE_X	29.183 in	29.183 in	0.000 in
POSTURE_DH15_EYE_Z	44.441 in	44.441 in	0.000 in
Longest Legs Male			
	UMTRI Value	TARDEC Value	Difference
POSTURE_DH16_HIP_X	30.501 in	30.502 in	0.000 in
POSTURE_DH16_HIP_Z	16.042 in	16.042 in	0.000 in
POSTURE_DH16_EYE_X	30.593 in	30.593 in	0.000 in
POSTURE_DH16_EYE_Z	42.661 in	42.661 in	0.000 in
Large Overall Male			
	UMTRI Value	TARDEC Value	Difference
POSTURE_DH17_HIP_X	30.327 in	30.327 in	0.000 in
POSTURE_DH17_HIP_Z	16.139 in	16.139 in	0.000 in
POSTURE_DH17_EYE_X	30.370 in	30.370 in	0.000 in
POSTURE_DH17_EYE_Z	44.400 in	44.400 in	0.000 in

TARDEC CAD values to agree with UMTRI spreadsheet values within
 ±0.100 inches
 ±0.100 degrees

Largest Observed Differences:
 0.000 inches

Values in agreement

230

10.2.7 TEST #7 – NUMERICAL RESULTS

Surrogate Steering Wheel			
	UMTRI Value	TARDEC Value	Difference
STEERING_WHEEL_X	13.300 in	13.300 in	0.000 in
STEERING_WHEEL_Z	29.000 in	29.000 in	0.000 in
Steering Wheel Preference Line			
	UMTRI Value	TARDEC Value	Difference
STRG_WHL_FWD_X	14.297 in	14.297 in	0.000 in
STRG_WHL_FWD_Z	27.559 in	27.559 in	0.000 in
STRG_WHL_RWD_X	3.733 in	3.733 in	0.000 in
STRG_WHL_RWD_Z	33.465 in	33.465 in	0.000 in
Steering Wheel Preference Zone			
	UMTRI Value	TARDEC Value	Difference
STRG_WHL_ZONE_Z	1.806 in	1.806 in	0.000 in
STRG_WHL_ZONE_Y	N/A	1.000 in	N/A
Accelerator Plane Angle (APA)			
	UMTRI Value	TARDEC Value	Difference
ACCEL_PEDAL_PLANE_ANG	41.438 deg	41.438 deg	0.000 deg
Origin (X)	0.000 in	0.000 in	0.000 in
Origin (Z)	0.000 in	0.000 in	0.000 in
BCFRP (X)	-5.903 in	-5.903 in	0.000 in
BCFRP (Z)	5.211 in	5.211 in	0.000 in
Seat Track Travel Range			
	UMTRI Value	TARDEC Value	Difference
SEAT_POSITION_CTR_OF_TRAVEL_X	30.119 in	30.121 in	0.002 in
SEAT_POSITION_CTR_OF_TRAVEL_Z	15.949 in	15.949 in	0.000 in
SEAT_POSITION_FORE_AFT_TRAVEL	7.515 in	7.506 in	0.008 in
SEAT_POSITION_VERTICAL_TRAVEL	3.698 in	3.695 in	0.004 in
Seat Back Angle			
	UMTRI Value	TARDEC Value	Difference
SEAT_BACK_ANGLE_LOWER_QUANTILE	18.133 deg	18.133 deg	0.001 deg
SEAT_BACK_ANGLE_UPPER_QUANTILE	30.285 deg	30.287 deg	0.002 deg
Eyellipse			
	UMTRI Value	TARDEC Value	Difference
EYELLIPSE_CENTROID_X	26.593 in	26.594 in	0.001 in
EYELLIPSE_CENTROID_Y (+/-)	1.280 in	1.280 in	0.000 in
EYELLIPSE_CENTROID_Z	42.304 in	42.304 in	0.000 in
EYELLIPSE_ANGLE_REL_X	18.600 deg	18.600 deg	0.000 deg
EYELLIPSE_X_AXIS_LENGTH	7.832 in	7.833 in	0.001 in
EYELLIPSE_Y_AXIS_LENGTH	2.284 in	2.285 in	0.001 in
EYELLIPSE_Z_AXIS_LENGTH	6.243 in	6.244 in	0.001 in

Helmet Boundary			
	UMTRI Value	TARDEC Value	Difference
HELMET_CONTOUR_CENTROID_X	29.837 in	29.838 in	0.001 in
HELMET_CONTOUR_CENTROID_Y (+/-)	2.185 in	2.185 in	0.000 in
HELMET_CONTOUR_CENTROID_Z	44.721 in	44.721 in	0.000 in
HELMET_CONTOUR_X_AXIS_LENGTH	18.284 in	18.285 in	0.001 in
HELMET_CONTOUR_Y_AXIS_LENGTH	9.882 in	9.883 in	0.001 in
HELMET_CONTOUR_Z_AXIS_LENGTH	14.328 in	14.329 in	0.001 in
Knee Boundary			
	UMTRI Value	TARDEC Value	Difference
KNEE_CONTOUR_WEIGHTED_CENT_X	10.896 in	10.896 in	0.000 in
KNEE_CONTOUR_WEIGHTED_CENT_Y (+/-)	7.331 in	7.331 in	0.000 in
KNEE_CONTOUR_WEIGHTED_CENT_Z	19.772 in	19.772 in	0.000 in
KNEE_CONTOUR_X_AXIS_LENGTH	8.436 in	8.435 in	0.001 in
KNEE_CONTOUR_Y_AXIS_LENGTH	9.529 in	9.527 in	0.002 in
KNEE_CONTOUR_Z_AXIS_LENGTH	7.134 in	7.130 in	0.004 in
KNEE_SHIN_ANGLE	29.013 deg	29.013 deg	0.000 deg
KNEE_THIGH_ANGLE	10.322 deg	10.322 deg	0.000 deg
Torso Boundary			
	UMTRI Value	TARDEC Value	Difference
TORSO_WEIGHTED_REF_PT_ENC_Z	16.513 in	16.517 in	0.004 in
TORSO_WEIGHTED_REF_PT_ENC_X	27.720 in	27.720 in	0.000 in
Elbow Boundary			
	UMTRI Value	TARDEC Value	Difference
ELBOW_WEIGHTED_CENT_X	27.276 in	27.276 in	0.000 in
ELBOW_WEIGHTED_CENT_Y (+/-)	14.707 in	14.707 in	0.000 in
ELBOW_WEIGHTED_CENT_Z	24.340 in	24.340 in	0.000 in
ELBOW_X_AXIS_LENGTH	8.744 in	8.742 in	0.002 in
ELBOW_Y_AXIS_LENGTH	4.102 in	4.101 in	0.001 in
ELBOW_Z_AXIS_LENGTH	6.486 in	6.488 in	0.001 in

TARDEC CAD values to agree with UMTRI spreadsheet values within
 ±0.100 inches
 ±0.100 degrees

Largest Observed Differences:
 0.008 inches
 0.001 degrees

Values in agreement

239

Small Overall Female			
	UMTRI Value	TARDEC Value	Difference
POSTURE_DHM1_HIP_X	24.353 in	24.353 in	0.000 in
POSTURE_DHM1_HIP_Z	15.879 in	15.879 in	0.000 in
POSTURE_DHM1_EYE_X	24.822 in	24.822 in	0.000 in
POSTURE_DHM1_EYE_Z	38.171 in	38.171 in	0.000 in
Small Overall Male			
	UMTRI Value	TARDEC Value	Difference
POSTURE_DHM2_HIP_X	26.475 in	26.475 in	0.000 in
POSTURE_DHM2_HIP_Z	15.989 in	15.989 in	0.000 in
POSTURE_DHM2_EYE_X	26.073 in	26.073 in	0.000 in
POSTURE_DHM2_EYE_Z	39.938 in	39.938 in	0.000 in
Average Size Male			
	UMTRI Value	TARDEC Value	Difference
POSTURE_DHM3_HIP_X	28.670 in	28.670 in	0.000 in
POSTURE_DHM3_HIP_Z	15.988 in	15.988 in	0.000 in
POSTURE_DHM3_EYE_X	27.481 in	27.481 in	0.000 in
POSTURE_DHM3_EYE_Z	42.162 in	42.162 in	0.000 in
Widest Shoulders Male			
	UMTRI Value	TARDEC Value	Difference
POSTURE_DHM4_HIP_X	29.678 in	29.678 in	0.000 in
POSTURE_DHM4_HIP_Z	15.977 in	15.977 in	0.000 in
POSTURE_DHM4_EYE_X	28.137 in	28.137 in	0.000 in
POSTURE_DHM4_EYE_Z	43.440 in	43.440 in	0.000 in
Longest Torso Male			
	UMTRI Value	TARDEC Value	Difference
POSTURE_DHM5_HIP_X	28.922 in	28.922 in	0.000 in
POSTURE_DHM5_HIP_Z	15.971 in	15.971 in	0.000 in
POSTURE_DHM5_EYE_X	27.647 in	27.647 in	0.000 in
POSTURE_DHM5_EYE_Z	44.441 in	44.441 in	0.000 in
Longest Legs Male			
	UMTRI Value	TARDEC Value	Difference
POSTURE_DHM6_HIP_X	31.194 in	31.194 in	0.000 in
POSTURE_DHM6_HIP_Z	16.042 in	16.042 in	0.000 in
POSTURE_DHM6_EYE_X	29.058 in	29.058 in	0.000 in
POSTURE_DHM6_EYE_Z	42.661 in	42.661 in	0.000 in
Large Overall Male			
	UMTRI Value	TARDEC Value	Difference
POSTURE_DHM7_HIP_X	31.020 in	31.020 in	0.000 in
POSTURE_DHM7_HIP_Z	16.139 in	16.139 in	0.000 in
POSTURE_DHM7_EYE_X	28.834 in	28.834 in	0.000 in
POSTURE_DHM7_EYE_Z	44.400 in	44.400 in	0.000 in

TARDEC CAD values to agree with UMTRI spreadsheet values within
 ±0.100 inches
 ±0.100 degrees

Largest Observed Differences:
 0.000 inches

Values in agreement

268

10.2.8 TEST #8 – NUMERICAL RESULTS

Surrogate Steering Wheel			
	UMTRI Value	TARDEC Value	Difference
STEERING_WHEEL_X	13.300 in	13.300 in	0.000 in
STEERING_WHEEL_Z	29.000 in	29.000 in	0.000 in
Steering Wheel Preference Line			
	UMTRI Value	TARDEC Value	Difference
STRG_WHL_FWD_X	13.716 in	13.716 in	0.000 in
STRG_WHL_FWD_Z	27.359 in	27.359 in	0.000 in
STRG_WHL_RWD_X	3.151 in	3.151 in	0.000 in
STRG_WHL_RWD_Z	33.465 in	33.465 in	0.000 in
Steering Wheel Preference Zone			
	UMTRI Value	TARDEC Value	Difference
STRG_WHL_ZONE_Z	1.515 in	1.516 in	0.001 in
STRG_WHL_ZONE_Y	N/A	1.000 in	N/A
Accelerator Plane Angle (APA)			
	UMTRI Value	TARDEC Value	Difference
ACCEL_PEDAL_PLANE_ANG	41.438 deg	41.438 deg	0.000 deg
Origin (X)	0.000 in	0.000 in	0.000 in
Origin (Z)	0.000 in	0.000 in	0.000 in
BOFRP (X)	-5.903 in	-5.903 in	0.000 in
BOFRP (Z)	5.211 in	5.211 in	0.000 in
Seat Track Travel Range			
	UMTRI Value	TARDEC Value	Difference
SEAT_POSITION_CTR_OF_TRAVEL_X	27.766 in	27.766 in	0.000 in
SEAT_POSITION_CTR_OF_TRAVEL_Z	16.220 in	16.220 in	0.000 in
SEAT_POSITION_FORE_AFT_TRAVEL	7.045 in	7.044 in	0.000 in
SEAT_POSITION_VERTICAL_TRAVEL	3.234 in	3.235 in	0.001 in
Seat Back Angle			
	UMTRI Value	TARDEC Value	Difference
SEAT_BACK_ANGLE_LOWER_QUANTILE	16.510 deg	16.507 deg	0.004 deg
SEAT_BACK_ANGLE_UPPER_QUANTILE	26.708 deg	26.712 deg	0.004 deg
Eyellipse			
	UMTRI Value	TARDEC Value	Difference
EYELLIPSE_CENTROID_X	26.271 in	26.271 in	0.000 in
EYELLIPSE_CENTROID_Y (+/-)	1.280 in	1.280 in	0.000 in
EYELLIPSE_CENTROID_Z	41.779 in	41.779 in	0.000 in
EYELLIPSE_ANGLE_REL_X	18.600 deg	18.600 deg	0.000 deg
EYELLIPSE_X_AXIS_LENGTH	6.899 in	6.899 in	0.000 in
EYELLIPSE_Y_AXIS_LENGTH	1.917 in	1.919 in	0.001 in
EYELLIPSE_Z_AXIS_LENGTH	5.484 in	5.486 in	0.002 in

Helmet Boundary			
	UMTRI Value	TARDEC Value	Difference
HELMET_CONTOUR_CENTROID_X	29.515 in	29.515 in	0.000 in
HELMET_CONTOUR_CENTROID_Y (+/-)	2.185 in	2.185 in	0.000 in
HELMET_CONTOUR_CENTROID_Z	44.196 in	44.196 in	0.000 in
HELMET_CONTOUR_X_AXIS_LENGTH	17.358 in	17.359 in	0.001 in
HELMET_CONTOUR_Y_AXIS_LENGTH	9.515 in	9.517 in	0.001 in
HELMET_CONTOUR_Z_AXIS_LENGTH	13.548 in	13.550 in	0.002 in
Knee Boundary			
	UMTRI Value	TARDEC Value	Difference
KNEE_CONTOUR_WEIGHTED_CENT_X	9.709 in	9.709 in	0.000 in
KNEE_CONTOUR_WEIGHTED_CENT_Y (+/-)	6.817 in	6.817 in	0.000 in
KNEE_CONTOUR_WEIGHTED_CENT_Z	19.163 in	19.163 in	0.000 in
KNEE_CONTOUR_X_AXIS_LENGTH	7.753 in	7.754 in	0.001 in
KNEE_CONTOUR_Y_AXIS_LENGTH	8.899 in	8.899 in	0.000 in
KNEE_CONTOUR_Z_AXIS_LENGTH	6.615 in	6.615 in	0.000 in
KNEE_SHIN_ANGLE	29.013 deg	29.013 deg	0.000 deg
KNEE_THIGH_ANGLE	8.489 deg	8.489 deg	0.000 deg
Torso Boundary			
	UMTRI Value	TARDEC Value	Difference
TORSO_WEIGHTED_REF_PT_PPE_X	21.517 in	21.517 in	0.000 in
TORSO_WEIGHTED_REF_PT_PPE_Z	33.076 in	33.076 in	0.000 in
Elbow Boundary			
	UMTRI Value	TARDEC Value	Difference
ELBOW_WEIGHTED_CENT_X	28.690 in	28.690 in	0.000 in
ELBOW_WEIGHTED_CENT_Y (+/-)	11.922 in	11.922 in	0.000 in
ELBOW_WEIGHTED_CENT_Z	21.981 in	21.981 in	0.000 in
ELBOW_X_AXIS_LENGTH	7.680 in	7.681 in	0.000 in
ELBOW_Y_AXIS_LENGTH	3.999 in	3.999 in	0.000 in
ELBOW_Z_AXIS_LENGTH	5.652 in	5.655 in	0.003 in

TARDEC CAD values to agree with UMTRI spreadsheet values within
 ±0.100 inches
 ±0.100 degrees

Largest Observed Differences:
 0.003 inches
 0.004 degrees

Values in agreement

277

Small Overall Female			
	UMTRI Value	TARDEC Value	Difference
POSTURE_DHM1_HIP_X	23.660 in	23.660 in	0.000 in
POSTURE_DHM1_HIP_Z	15.879 in	15.879 in	0.000 in
POSTURE_DHM1_EYE_X	24.940 in	24.940 in	0.000 in
POSTURE_DHM1_EYE_Z	38.171 in	38.171 in	0.000 in
Small Overall Male			
	UMTRI Value	TARDEC Value	Difference
POSTURE_DHM2_HIP_X	25.782 in	25.782 in	0.000 in
POSTURE_DHM2_HIP_Z	15.989 in	15.989 in	0.000 in
POSTURE_DHM2_EYE_X	26.191 in	26.191 in	0.000 in
POSTURE_DHM2_EYE_Z	39.938 in	39.938 in	0.000 in
Average Size Male			
	UMTRI Value	TARDEC Value	Difference
POSTURE_DHM3_HIP_X	27.977 in	27.977 in	0.000 in
POSTURE_DHM3_HIP_Z	15.988 in	15.988 in	0.000 in
POSTURE_DHM3_EYE_X	27.599 in	27.599 in	0.000 in
POSTURE_DHM3_EYE_Z	42.162 in	42.162 in	0.000 in
Widest Shoulders Male			
	UMTRI Value	TARDEC Value	Difference
POSTURE_DHM4_HIP_X	28.985 in	28.986 in	0.000 in
POSTURE_DHM4_HIP_Z	15.977 in	15.977 in	0.000 in
POSTURE_DHM4_EYE_X	28.259 in	28.256 in	0.000 in
POSTURE_DHM4_EYE_Z	43.440 in	43.440 in	0.000 in
Longest Torso Male			
	UMTRI Value	TARDEC Value	Difference
POSTURE_DHM5_HIP_X	28.229 in	28.229 in	0.000 in
POSTURE_DHM5_HIP_Z	15.971 in	15.971 in	0.000 in
POSTURE_DHM5_EYE_X	27.765 in	27.765 in	0.000 in
POSTURE_DHM5_EYE_Z	44.441 in	44.441 in	0.000 in
Longest Legs Male			
	UMTRI Value	TARDEC Value	Difference
POSTURE_DHM6_HIP_X	30.504 in	30.506 in	0.000 in
POSTURE_DHM6_HIP_Z	16.042 in	16.042 in	0.000 in
POSTURE_DHM6_EYE_X	29.176 in	29.176 in	0.000 in
POSTURE_DHM6_EYE_Z	42.661 in	42.661 in	0.000 in
Large Overall Male			
	UMTRI Value	TARDEC Value	Difference
POSTURE_DHM7_HIP_X	30.327 in	30.327 in	0.000 in
POSTURE_DHM7_HIP_Z	16.139 in	16.139 in	0.000 in
POSTURE_DHM7_EYE_X	28.952 in	28.952 in	0.000 in
POSTURE_DHM7_EYE_Z	44.400 in	44.400 in	0.000 in

TARDEC CAD values to agree with UMTRI spreadsheet values within
 ±0.100 inches
 ±0.100 degrees

Largest Observed Differences:
 0.000 inches

Values in agreement

306

10.2.9 TEST #9 – NUMERICAL RESULTS

Surrogate Steering Wheel			
STEERING_WHEEL_X	UMTRI Value	TARDEC Value	Difference
	13.300 in	13.300 in	0.000 in
STEERING_WHEEL_Z	29.000 in	29.000 in	0.000 in
Steering Wheel Preference Line			
STRG_WHL_FWD_X	UMTRI Value	TARDEC Value	Difference
	13.716 in	13.716 in	0.000 in
STRG_WHL_FWD_Z	27.559 in	27.559 in	0.000 in
STRG_WHL_RWD_X	3.151 in	3.151 in	0.000 in
STRG_WHL_RWD_Z	33.465 in	33.465 in	0.000 in
Steering Wheel Preference Zone			
STRG_WHL_ZONE_Z	UMTRI Value	TARDEC Value	Difference
	1.515 in	1.516 in	0.001 in
STRG_WHL_ZONE_Y	N/A	1.000 in	N/A
Accelerator Plane Angle (APA)			
ACCEL_PEDAL_PLANE_ANG	UMTRI Value	TARDEC Value	Difference
	41.438 deg	41.438 deg	0.000 deg
Origin (X)	0.000 in	0.000 in	0.000 in
Origin (Z)	0.000 in	0.000 in	0.000 in
BOFRP (X)	-5.903 in	-5.903 in	0.000 in
BOFRP (Z)	5.211 in	5.211 in	0.000 in
Seat Track Travel Range			
SEAT_POSITION_CTR_OF_TRAVEL_X	UMTRI Value	TARDEC Value	Difference
	26.947 in	26.947 in	0.000 in
SEAT_POSITION_CTR_OF_TRAVEL_Z	16.319 in	16.319 in	0.000 in
SEAT_POSITION_FORE_AFT_TRAVEL	7.044 in	7.044 in	0.000 in
SEAT_POSITION_VERTICAL_TRAVEL	3.234 in	3.235 in	0.001 in
Seat Back Angle			
SEAT_BACK_ANGLE_LOWER_QUANTILE	UMTRI Value	TARDEC Value	Difference
	16.510 deg	16.507 deg	0.004 deg
SEAT_BACK_ANGLE_UPPER_QUANTILE	26.708 deg	26.712 deg	0.004 deg
Eyellipse			
EYELLIPSE_CENTROID_X	UMTRI Value	TARDEC Value	Difference
	27.668 in	27.668 in	0.000 in
EYELLIPSE_CENTROID_Y (+/-)	1.280 in	1.280 in	0.000 in
EYELLIPSE_CENTROID_Z	41.365 in	41.365 in	0.000 in
EYELLIPSE_ANGLE_REL_X	18.600 deg	18.600 deg	0.000 deg
EYELLIPSE_X_AXIS_LENGTH	6.899 in	6.899 in	0.001 in
EYELLIPSE_Y_AXIS_LENGTH	1.917 in	1.919 in	0.001 in
EYELLIPSE_Z_AXIS_LENGTH	5.484 in	5.486 in	0.002 in

Helmet Boundary			
The ACU ensemble does not include a helmet			
Knee Boundary			
KNEE_CONTOUR_WEIGHTED_CENT_X	UMTRI Value	TARDEC Value	Difference
	9.796 in	9.796 in	0.000 in
KNEE_CONTOUR_WEIGHTED_CENT_Y (+/-)	6.817 in	6.817 in	0.000 in
KNEE_CONTOUR_WEIGHTED_CENT_Z	19.163 in	19.163 in	0.000 in
KNEE_CONTOUR_X_AXIS_LENGTH	7.753 in	7.754 in	0.001 in
KNEE_CONTOUR_Y_AXIS_LENGTH	8.895 in	8.896 in	0.000 in
KNEE_CONTOUR_Z_AXIS_LENGTH	6.615 in	6.615 in	0.000 in
KNEE_SHIN_ANGLE	29.013 deg	29.013 deg	0.000 deg
KNEE_THIGH_ANGLE	8.489 deg	8.489 deg	0.000 deg
Torso Boundary			
A torso boundary is not provided when the ACU ensemble is chosen			
Elbow Boundary			
ELBOW_WEIGHTED_CENT_X	UMTRI Value	TARDEC Value	Difference
	28.796 in	28.796 in	0.000 in
ELBOW_WEIGHTED_CENT_Y (+/-)	11.048 in	11.048 in	0.000 in
ELBOW_WEIGHTED_CENT_Z	21.296 in	21.296 in	0.000 in
ELBOW_X_AXIS_LENGTH	7.680 in	7.681 in	0.000 in
ELBOW_Y_AXIS_LENGTH	3.599 in	3.599 in	0.000 in
ELBOW_Z_AXIS_LENGTH	5.652 in	5.655 in	0.003 in

TARDEC CAD values to agree with UMTRI spreadsheet values within
 ±0.100 inches
 ±0.100 degrees

Largest Observed Differences:
 0.003 inches
 0.004 degrees

Values in agreement

315

Small Overall Female			
POSTURE_DHM1_HIP_X	UMTRI Value	TARDEC Value	Difference
	23.660 in	23.660 in	0.000 in
POSTURE_DHM1_HIP_Z	15.879 in	15.879 in	0.000 in
POSTURE_DHM1_EYE_X	26.357 in	26.357 in	0.000 in
POSTURE_DHM1_EYE_Z	38.171 in	38.171 in	0.000 in
Small Overall Male			
POSTURE_DHM2_HIP_X	UMTRI Value	TARDEC Value	Difference
	25.782 in	25.782 in	0.000 in
POSTURE_DHM2_HIP_Z	15.989 in	15.989 in	0.000 in
POSTURE_DHM2_EYE_X	27.608 in	27.608 in	0.000 in
POSTURE_DHM2_EYE_Z	39.938 in	39.938 in	0.000 in
Average Size Male			
POSTURE_DHM3_HIP_X	UMTRI Value	TARDEC Value	Difference
	27.977 in	27.977 in	0.000 in
POSTURE_DHM3_HIP_Z	15.988 in	15.988 in	0.000 in
POSTURE_DHM3_EYE_X	29.017 in	29.017 in	0.000 in
POSTURE_DHM3_EYE_Z	42.162 in	42.162 in	0.000 in
Widest Shoulders Male			
POSTURE_DHM4_HIP_X	UMTRI Value	TARDEC Value	Difference
	28.985 in	28.986 in	0.000 in
POSTURE_DHM4_HIP_Z	15.977 in	15.977 in	0.000 in
POSTURE_DHM4_EYE_X	29.673 in	29.673 in	0.000 in
POSTURE_DHM4_EYE_Z	43.440 in	43.440 in	0.000 in
Longest Torso Male			
POSTURE_DHM5_HIP_X	UMTRI Value	TARDEC Value	Difference
	28.229 in	28.229 in	0.000 in
POSTURE_DHM5_HIP_Z	15.971 in	15.971 in	0.000 in
POSTURE_DHM5_EYE_X	29.183 in	29.183 in	0.000 in
POSTURE_DHM5_EYE_Z	44.441 in	44.441 in	0.000 in
Longest Legs Male			
POSTURE_DHM6_HIP_X	UMTRI Value	TARDEC Value	Difference
	30.501 in	30.502 in	0.000 in
POSTURE_DHM6_HIP_Z	16.042 in	16.042 in	0.000 in
POSTURE_DHM6_EYE_X	30.593 in	30.593 in	0.000 in
POSTURE_DHM6_EYE_Z	42.661 in	42.661 in	0.000 in
Large Overall Male			
POSTURE_DHM7_HIP_X	UMTRI Value	TARDEC Value	Difference
	30.327 in	30.327 in	0.000 in
POSTURE_DHM7_HIP_Z	16.139 in	16.139 in	0.000 in
POSTURE_DHM7_EYE_X	30.370 in	30.370 in	0.000 in
POSTURE_DHM7_EYE_Z	44.400 in	44.400 in	0.000 in

TARDEC CAD values to agree with UMTRI spreadsheet values within
 ±0.100 inches
 ±0.100 degrees

Largest Observed Differences:
 0.000 inches

Values in agreement

339

10.2.10 TEST #10 – NUMERICAL RESULTS

Surrogate Steering Wheel			
STEERING_WHEEL_X	UMTRI Value	TARDEC Value	Difference
	13.300 in	13.300 in	0.000 in
STEERING_WHEEL_Z	29.000 in	29.000 in	0.000 in
Steering Wheel Preference Line			
STRG_WHL_FWD_X	UMTRI Value	TARDEC Value	Difference
	13.716 in	13.716 in	0.000 in
STRG_WHL_FWD_Z	27.359 in	27.359 in	0.000 in
STRG_WHL_RWD_X	3.151 in	3.151 in	0.000 in
STRG_WHL_RWD_Z	33.465 in	33.465 in	0.000 in
Steering Wheel Preference Zone			
STRG_WHL_ZONE_Z	UMTRI Value	TARDEC Value	Difference
	1.515 in	1.516 in	0.001 in
STRG_WHL_ZONE_Y	N/A	1.000 in	N/A
Accelerator Plane Angle (APA)			
ACCEL_PEDAL_PLANE_ANG	UMTRI Value	TARDEC Value	Difference
	41.438 deg	41.438 deg	0.000 deg
Origin (X)	0.000 in	0.000 in	0.000 in
Origin (Z)	0.000 in	0.000 in	0.000 in
BOFRP (X)	-5.903 in	-5.903 in	0.000 in
BOFRP (Z)	5.211 in	5.211 in	0.000 in
Seat Track Travel Range			
SEAT_POSITION_CTR_OF_TRAVEL_X	UMTRI Value	TARDEC Value	Difference
	27.766 in	27.766 in	0.000 in
SEAT_POSITION_CTR_OF_TRAVEL_Z	16.023 in	16.023 in	0.000 in
SEAT_POSITION_FORE_AFT_TRAVEL	7.044 in	7.044 in	0.000 in
SEAT_POSITION_VERTICAL_TRAVEL	3.234 in	3.235 in	0.001 in
Seat Back Angle			
SEAT_BACK_ANGLE_LOWER_QUANTILE	UMTRI Value	TARDEC Value	Difference
	19.110 deg	19.107 deg	0.004 deg
SEAT_BACK_ANGLE_UPPER_QUANTILE	29.308 deg	29.312 deg	0.004 deg
Eyellipse			
EYELLIPSE_CENTROID_X	UMTRI Value	TARDEC Value	Difference
	26.271 in	26.271 in	0.000 in
EYELLIPSE_CENTROID_Y (+/-)	1.280 in	1.280 in	0.000 in
EYELLIPSE_CENTROID_Z	41.582 in	41.582 in	0.000 in
EYELLIPSE_ANGLE_REL_X	18.600 deg	18.600 deg	0.000 deg
EYELLIPSE_X_AXIS_LENGTH	6.899 in	6.899 in	0.001 in
EYELLIPSE_Y_AXIS_LENGTH	1.917 in	1.919 in	0.001 in
EYELLIPSE_Z_AXIS_LENGTH	5.484 in	5.486 in	0.002 in

Helmet Boundary			
HELMET_CONTOUR_CENTROID_X	UMTRI Value	TARDEC Value	Difference
	29.515 in	29.515 in	0.000 in
HELMET_CONTOUR_CENTROID_Y (+/-)	2.185 in	2.185 in	0.000 in
HELMET_CONTOUR_CENTROID_Z	43.999 in	43.999 in	0.000 in
HELMET_CONTOUR_X_AXIS_LENGTH	17.358 in	17.359 in	0.001 in
HELMET_CONTOUR_Y_AXIS_LENGTH	9.515 in	9.517 in	0.001 in
HELMET_CONTOUR_Z_AXIS_LENGTH	13.548 in	13.550 in	0.002 in
Knee Boundary			
KNEE_CONTOUR_WEIGHTED_CENT_X	UMTRI Value	TARDEC Value	Difference
	9.709 in	9.709 in	0.000 in
KNEE_CONTOUR_WEIGHTED_CENT_Y (+/-)	6.817 in	6.817 in	0.000 in
KNEE_CONTOUR_WEIGHTED_CENT_Z	19.163 in	19.163 in	0.000 in
KNEE_CONTOUR_X_AXIS_LENGTH	7.753 in	7.754 in	0.001 in
KNEE_CONTOUR_Y_AXIS_LENGTH	8.899 in	8.899 in	0.000 in
KNEE_CONTOUR_Z_AXIS_LENGTH	6.615 in	6.615 in	0.000 in
KNEE_SHIN_ANGLE	29.013 deg	29.013 deg	0.000 deg
KNEE_THIGH_ANGLE	8.489 deg	8.489 deg	0.000 deg
Torso Boundary			
TORSO_WEIGHTED_REF_PT_ENC_Z	UMTRI Value	TARDEC Value	Difference
	15.983 in	15.983 in	0.000 in
TORSO_WEIGHTED_REF_PT_ENC_X	27.795 in	27.795 in	0.000 in
Elbow Boundary			
ELBOW_WEIGHTED_CENT_X	UMTRI Value	TARDEC Value	Difference
	24.717 in	24.717 in	0.000 in
ELBOW_WEIGHTED_CENT_Y (+/-)	14.276 in	14.276 in	0.000 in
ELBOW_WEIGHTED_CENT_Z	24.331 in	24.331 in	0.000 in
ELBOW_X_AXIS_LENGTH	7.680 in	7.681 in	0.000 in
ELBOW_Y_AXIS_LENGTH	3.999 in	3.999 in	0.000 in
ELBOW_Z_AXIS_LENGTH	5.652 in	5.655 in	0.003 in

TARDEC CAD values to agree with UMTRI spreadsheet values within
 ±0.100 inches
 ±0.100 degrees

Largest Observed Differences:
 0.003 inches
 0.004 degrees

Values in agreement

348

Small Overall Female			
POSTURE_DHM1_HIP_X	UMTRI Value	TARDEC Value	Difference
	23.660 in	23.660 in	0.000 in
POSTURE_DHM1_HIP_Z	15.879 in	15.879 in	0.000 in
POSTURE_DHM1_EYE_X	24.940 in	24.940 in	0.000 in
POSTURE_DHM1_EYE_Z	38.171 in	38.171 in	0.000 in
Small Overall Male			
POSTURE_DHM2_HIP_X	UMTRI Value	TARDEC Value	Difference
	25.782 in	25.782 in	0.000 in
POSTURE_DHM2_HIP_Z	15.989 in	15.989 in	0.000 in
POSTURE_DHM2_EYE_X	26.191 in	26.191 in	0.000 in
POSTURE_DHM2_EYE_Z	39.938 in	39.938 in	0.000 in
Average Size Male			
POSTURE_DHM3_HIP_X	UMTRI Value	TARDEC Value	Difference
	27.977 in	27.977 in	0.000 in
POSTURE_DHM3_HIP_Z	15.988 in	15.988 in	0.000 in
POSTURE_DHM3_EYE_X	27.599 in	27.599 in	0.000 in
POSTURE_DHM3_EYE_Z	42.162 in	42.162 in	0.000 in
Widest Shoulders Male			
POSTURE_DHM4_HIP_X	UMTRI Value	TARDEC Value	Difference
	28.985 in	28.986 in	0.000 in
POSTURE_DHM4_HIP_Z	15.977 in	15.977 in	0.000 in
POSTURE_DHM4_EYE_X	28.259 in	28.256 in	0.000 in
POSTURE_DHM4_EYE_Z	43.440 in	43.440 in	0.000 in
Longest Torso Male			
POSTURE_DHM5_HIP_X	UMTRI Value	TARDEC Value	Difference
	28.229 in	28.229 in	0.000 in
POSTURE_DHM5_HIP_Z	15.971 in	15.971 in	0.000 in
POSTURE_DHM5_EYE_X	27.765 in	27.765 in	0.000 in
POSTURE_DHM5_EYE_Z	44.441 in	44.441 in	0.000 in
Longest Legs Male			
POSTURE_DHM6_HIP_X	UMTRI Value	TARDEC Value	Difference
	30.504 in	30.506 in	0.000 in
POSTURE_DHM6_HIP_Z	16.042 in	16.042 in	0.000 in
POSTURE_DHM6_EYE_X	29.176 in	29.176 in	0.000 in
POSTURE_DHM6_EYE_Z	42.661 in	42.661 in	0.000 in
Large Overall Male			
POSTURE_DHM7_HIP_X	UMTRI Value	TARDEC Value	Difference
	30.327 in	30.327 in	0.000 in
POSTURE_DHM7_HIP_Z	16.139 in	16.139 in	0.000 in
POSTURE_DHM7_EYE_X	28.952 in	28.952 in	0.000 in
POSTURE_DHM7_EYE_Z	44.400 in	44.400 in	0.000 in

TARDEC CAD values to agree with UMTRI spreadsheet values within
 ±0.100 inches
 ±0.100 degrees

Largest Observed Differences:
 0.000 inches

Values in agreement

377

10.3 APPENDIX C – REFERENCES

Department of Defense. (2008). *Standard Practice – Documentation of Verification, Validation, and Accreditation (VV&A) for Models and Simulations*. Alexandria, VA. (MIL-STD-3022).

Department of Defense. (2012). *Design Criteria Standard – Human Engineering*. Redstone Arsenal, AL. (MIL-STD-1472G).

Huston II, F., Zielinski, G., and Reed, M. (2016). *Creation of the Driver Fixed Heel Point (FHP) CAD Accommodation Model for Military Ground Vehicle Design*. DTIC Technical Report TR-28004. NDIA Ground Vehicle Systems Engineering and Technology Symposium (GVSETS) Modeling and Simulation, Testing and Validation (MSTV) Mini-Symposium August 2 – 4, Novi, Michigan.

Reed, M. (2016). *Preferred Steering Wheel Locations for Fixed-Heel-Point Driver Stations*. University of Michigan Transportation Research Institute, Ann Arbor, MI

Reed, M. (2016). *Seated Soldier Elbow Clearance Zones*. University of Michigan Transportation Research Institute, Ann Arbor, MI.

Reed, M. (2014). *Seated Soldier Posture Prediction 2014-09-01* [Excel spreadsheet]. University of Michigan Transportation Research Institute, Ann Arbor, MI.

Reed, M. (2017). *Soldier Driver Accommodation Models 2017-05-03* [Excel Spreadsheet]. MI: University of Michigan Transportation Research Institute.

Reed, M., and Ebert, S. (2013). *The Seated Soldier Study: Posture and Body Shape in Vehicle Seats*. Final Report UMTRI-2013-13. University of Michigan Transportation Research Institute, Ann Arbor, MI. <https://deepblue.lib.umich.edu/handle/2027.42/109725>

SAE Recommended Practice, *SAE J1050 Describing and Measuring the Driver's Field of View*, SAE, 2009.

Zerehsaz, Y., Ebert, S., and Reed, M. (2014). *Development of Accommodation Models for Soldiers in Vehicles-Driver*. Final Report UMTRI-2014-26. University of Michigan Transportation Research Institute, Ann Arbor, MI. <https://deepblue.lib.umich.edu/handle/2027.42/112059>

Zielinski, G. and Huston II, F. (2017). *Fixed Heel Point (FHP) Verification and Validation (V and V) Plan*. DTIC Technical Report TR-28822. U.S. Army Tank Automotive Research, Development, and Engineering Center, Warren, MI.

Zielinski, G., Huston II, F., Kozycki, R., Kouba, R., and Wodzinski, C. (2015). *Introduction to Boundary Manikins and Accommodation Models for Military Ground Vehicle Occupant Centric*

Design. DTIC Technical Report TR-26516. U.S. Army Tank Automotive Research,
Development, and Engineering Center, Warren, MI.

10.4 APPENDIX D – ACRONYMS

ACH	Advanced Combat Helmet
ACT	Advanced Concepts Team
ACU	Advanced Combat Uniform
AHP	Accelerator Heel Point
AN SUR	Army Anthropometric Survey
APA	Accelerator Plane Angle
ARLHRED	Army Research Laboratory Human Research and Engineering Directorate
CAD	Computer-Aided Design
COTS	Commercial Off-The-Shelf
CSI	Center for System Integration
EMD	Engineering Manufacturing and Development
ENC	Encumbered
ES API	Enhanced Small Arms Protective Insert
ESBI	Enhanced Side Ballistic Inserts
FE	Field Element
FEP	Fixed Eye Point
FHP	Fixed Heel Point
FOV	Field-of-View
GVSP	Ground Vehicle Survivability and Protection
HARP	Human Accommodation Reference Point
HFE	Human Factors Engineering
HSI	Human Systems Integration
IOTV	Improved Outer Tactical Vest
JTTS	Joint Tactical Transportation System
MCoE	Maneuver Center of Excellence
MERS	Marine Expeditionary Rifle Squad
MS	Milestone
M&S	Modeling and Simulation
NSRDEC	Natick Soldier Research Development and Engineering Center
OCP	Occupant Centric Platform
OOH	Out-of-Hatch
PPE	Personal Protective Equipment
SIAT	System Engineering, Interoperability, Architecture & Technology
SIP	Seat Index Point
SME	Subject Matter Experts
SWP	Steering Wheel Point
TACOM	Tank Automotive Command
TARDEC	Tank Automotive Research, Development, and Engineering Center
TECD	Technology Capability Demonstration
UMTRI	University of Michigan Transportation Research Institute

10.5 APPENDIX E – DISTRIBUTION LIST

US Army Tank Automotive Research, Development, and Engineering Center (TARDEC):

- Gale L. Zielinski, Mechanical Engineer/Advanced Concepts Team (ACT), RDECOM-TARDEC, Warren, MI 48397-5000, Office: 586-282-5287, E-Mail: gale.l.zielinski.civ@mail.mil
- Frank J. Huston II, Mechanical Engineer/ACT, RDECOM-TARDEC, Warren, MI 48397-5000, Office: 586-282-5657, E-Mail: frank.j.huston.civ@mail.mil
- Russell D. Kouba, Team Leader/ ACT, RDECOM-TARDEC, Warren, MI 48397-5000, Office: 586-282-7806, E-Mail: russell.d.kouba.civ@mail.mil
- Gale M. Litrichin, Principal Seat Engineer – Interior Blast Mitigation Team (IBMT)/Ground Vehicle Survivability and Protection (GVSP), RDECOM-TARDEC, Warren MI 48397-5000, Office: 586-282-0608, E-Mail: gale.m.litrichin.civ@mail.mil
- Eric S. Paternoster, CSI Systems Integration Team, RDECOM-TARDEC, Warren MI 48397-5000, Office: 586-282-0976, E-Mail: eric.s.paternoster2.civ@mail.mil

Army Research Laboratory (ARL) Human Research and Engineering Directorate (HRED):

- Richard W. Kozycki, ARL HRED, RDRL-HRM-B, Aberdeen Proving Ground, MD 21005-5425, Office: (410) 278-5880, E-Mail: richard.w.kozycki.civ@mail.mil
- Cheryl A. Burns, ARL HRED, RDRL-HRM-H, Fort Knox, KY 40121, Office: (502) 624-1607, E-Mail: cheryl.a.burns12.civ@mail.mil
- David A. Hullinger, Human Factors Engineer, ARL HRED – TACOM Field Element, RDRL-HRM-CU, Warren, MI 48397-5000, Office: 586-282-8669, E-Mail: david.a.hullinger.civ@mail.mil
- Joseph R. Urda, Human Factors Engineer, ARL HRED – TACOM Field , TACOM Field Element, RDRL-HRM-CU, Warren, MI 48397-5000, Office: (586) 282-5662, E-Mail: joseph.r.urda.civ@mail.mil

US Army Natick Soldier Research, Development, and Engineering Center (NSRDEC):

- Steven Paquette, Anthropology Team Leader, NSRDEC, Natick, MA 01760, Office: (508) 233-5430, E-Mail: steven.p.paquette.civ@mail.mil
- Joseph L. Parham, Research Anthropologist, NSRDEC, Natick, MA 01760, Office: (508) 233-5787, E-Mail: joseph.l.parham2.civ@mail.mil
- Dawn L. Woods, Human Factors Engineer, NSRDEC, Natick, MA 01760, Office: 508-233-5069, E-Mail: dawn.l.woods6.civ@mail.mil

Maneuver Center of Excellence (MCoE):

- Gustave R. Steenborg, Systems Safety Engineer, Mounted Requirements Division
Capabilities Development and Integration Directorate MCoE, Fort Benning, GA 31905,
Office: (708) 545-0751, E-Mail: gustave.r.steenborg.civ@mail.mil

Marine Expeditionary Rifle Squad (MERS):

- Brian D. Corner, PhD., Research Anthropologist, Systems Engineering, Interoperability,
Architectures & Technology (SIAT), Office: 703-432-3231, E-Mail:
brian.corner@usmc.mil

Naval Surface Warfare Center – Warfare Systems Department:

- Brian Keeven, Engineer - Human System Integration, Dahlgren, VA 22448, Office: (540)
653-1007, E-Mail: brian.keeven@navy.mil

University of Michigan Transportation Research Institute (UMTRI):

- Matthew P. Reed, PhD., Research Professor and Head Biosciences Group, UMTRI, Ann
Arbor, MI 48109-2150, Office: 734-936-1111, E-Mail: mreed@umich.edu

10.6 APPENDIX F – VERIFICATION PLAN

The *Fixed Heel Point Verification and Validation (V and V) Plan – Rev A* (2017) is located in the Defense Technical Information Center (DTIC) database. The reference for the final plan is below:

Zielinski, G. and Huston II, F. (2017). *Fixed Heel Point (FHP) Verification and Validation (V and V) Plan*. DTIC Technical Report TR-28822. Distribution A. U.S. Army Tank Automotive Research, Development, and Engineering Center, Warren, MI.

10.7 APPENDIX G - INITIAL TASK ANALYSIS

Ten different test scenarios were completed for the 1 August 2017 verification event. This section outlines each test scenario and compares TARDEC's CAD results to UMTRI's Microsoft Excel results. The model geometry was adjusted by changing values assigned to the input parameter table in the CAD top assembly and then regenerating the model. This information was provided to all verification invitees prior to the event.

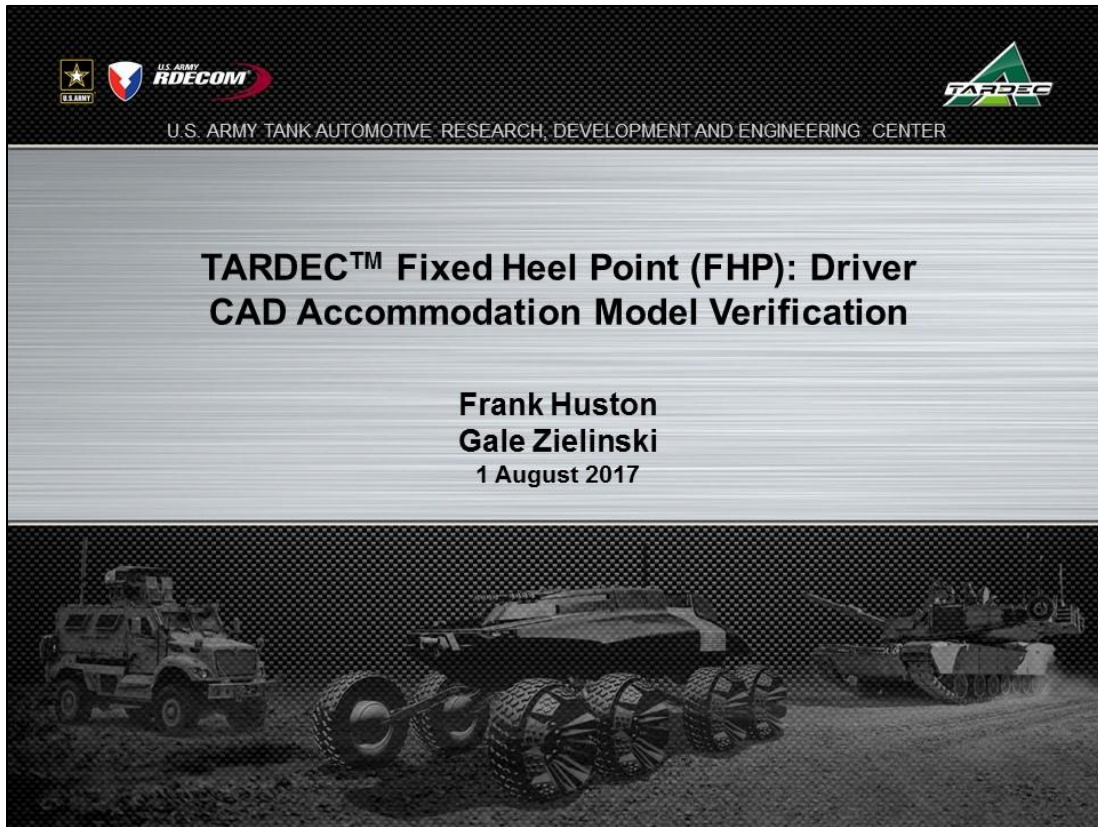

Purpose 

Verify the TARDEC™ Fixed Heel Point (FHP): Driver CAD accommodation model

What is verification?

Verification, per the *Department of Defense Standard Practice Documentation of Verification, Validation, and Accreditation (VV&A) for Models and Simulation (2008)* is defined as follows:

Verification is the process of determining that a model, simulation, or federation of models and simulations implementations and their associated data accurately represents the developer's conceptual description and specifications.

Does the TARDEC Fixed Heel Point (FHP): Driver CAD accommodation model output match the UMTRI accommodation model spread sheet output?

2

Defining In-Vehicle Occupant Positioning Posture Prediction and Accommodation Models 

Empirical Soldier data is being used to develop CAD tools that realistically posture and position boundary manikins and predict population body boundaries for crew and squad

- Results, which are repeatable, allow for vehicle design from the occupant outward
- Trades between the vehicle and its occupants are data driven and quantifiable

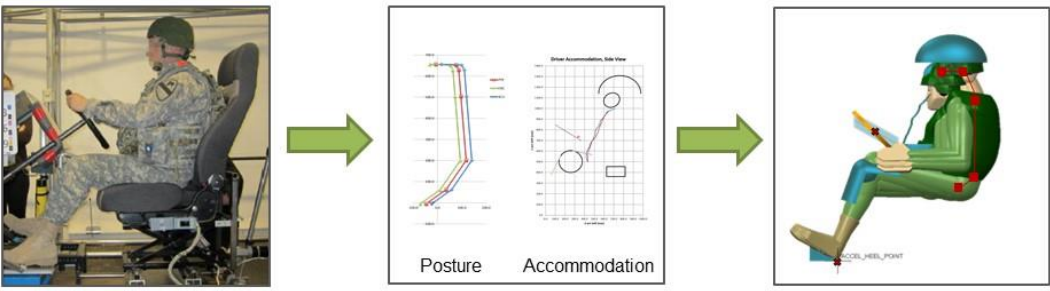

```
graph LR; A[UMTRI Seated Soldier Study] --> B[UMTRI Posture Prediction]; B --> C[TARDEC CAD Integration]
```

UMTRI Seated Soldier Study
Soldier preferred posture and positioning, while wearing varying levels of encumbrance, were recorded in driver and squad mockups

UMTRI Posture Prediction
Statistical analysis of the data summarized in Excel-based posture prediction (individuals) and accommodation models (populations)

TARDEC CAD Integration
Morphing parametric CAD models created that respond to user inputs for Soldier population, accommodation level, and vehicle environment

3

CAD Accommodation Tools, A Layered Approach

The TARDEC™ FHP: Driver CAD Accommodation Model consists of the following:

Basic Accommodation
Includes both population body boundaries representing the aggregate of all occupant positions in the vehicle environment for the target design population and necessary vehicle adjustment ranges

Clearance (2.0 inches)
Clearance between the target design population and the surrounding vehicle environment

Vision Zones
The direct field of view (divided into primary, secondary, and tertiary zones) using a combination of vertical and horizontal visual fields from MIL-STD-1472 and SAE J1050

Boundary Manikins
Positioned boundary manikins provide another reference for design

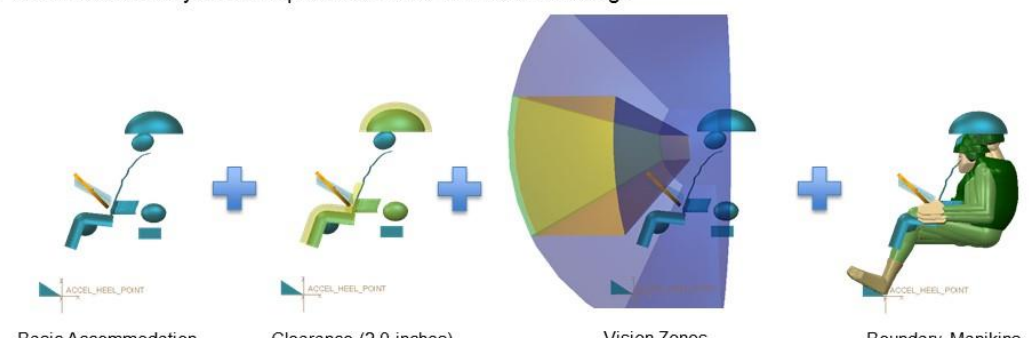

Basic Accommodation Clearance (2.0 inches) Vision Zones Boundary Manikins

4

What is the Scope of the Verification?

The TARDEC™ Fixed Heel Point (FHP): Driver CAD accommodation model will be audited to determine the following, which is based on Soldier data and SME guidance:

- 1) Determine if the accommodation boundaries match when using either the TARDECCAD model or the UMTRI Microsoft Excel spreadsheet *Soldier Driver Accommodation Models 2017-06-08*
- 2) Determine if the steering wheel placement zone matches the guidance provided in the UMTRI paper *Preferred Steering Wheel Locations for Fixed-Heel-Point Driver Stations 2016-09-20*
- 3) Determine if the clearance zones (helmet, abdominal, knees, legs, and shins) match what Subject Matter Experts (SME) interpreted using MIL-STD-1472G
- 4) Determine if direct field of view (primary, secondary, and tertiary) matches what SMEs interpreted using MIL-STD-1472G and SAE J1050
- 5) Determine if ground intercept can be calculated using the model based on MIL-STD-1472G ground intercept requirement
- 6) Determine if the hip and eye point of the CAD boundary manikins match the UMTRI Microsoft Excel spreadsheet *Seated Soldier Posture Prediction 2014-09-01*

5

Acceptability Criteria



Inputs			Outputs		
#	M&S Requirement	Acceptability Criteria	#	M&S Requirement	Acceptability Criteria
1	Model allows for input of the Steering Wheel Point (SWP) in "X" (horizontal) and "Z" (vertical) coordinates.	1.1 Input parameter is available for steering wheel position in X.	7	Model predicts the Steering Wheel Preference Line.	7.1 Model outputs a Steering Wheel Preference Line.
		1.2 Input parameter is available for steering wheel position in Z.			7.2 Model outputs a Steering Wheel Preference Line.
2	Model allows for selection of ensemble as either PPE or ENC in model.	2.1 Ensemble selection of PPE in model.	8	Model predicts the knee contour with leg and thigh segment based on MIL-GTD-1472H draft recommendations.	8.1 Model outputs a knee ellipsoid.
		2.2 Ensemble selection of ENC in model.			8.2 Model outputs a knee ellipsoid.
3	Model allows for input of seat hydration pack relief.	3.1 Hydration pack relief selection of "yes" in model.	9	Model provides a clearance zone for the thigh to steering wheel based on MIL-GTD-1472H draft recommendations.	9.1 Model outputs a 2" clearance zone from the top of the thigh to the bottom of the steering wheel as measured in side-view.
		3.2 Hydration pack relief selection of "no" in model.			9.2 Model outputs a 2" clearance zone from the top of the thigh to the front of the leg segment.
4	Model allows for selection of either GAE JB26 or ISO 5353 for the Human Accommodation Reference Point (HARP).	4.1 HARP measurement tool selection of GAE JB26 in model.	10	Model provides a lateral clearance zone for the elbow contours based on MIL-GTD-1472H draft recommendations.	10.1 Model outputs primary vision zone that adjusts with model inputs.
		4.2 HARP measurement tool selection of ISO 5353 in model.			10.2 Model outputs secondary vision zone that adjusts with model inputs.
5	Model allows for input of population gender mix (e.g. 85% Male/15% Female).	5.1 Fraction male input option in model.	11	Model depicts a best-case ground intercept.	11.1 Model outputs a best-case ground intercept with input of driver's accommodation value of a censored seat travel that adjusts with model inputs.
		5.2 Target accommodation input option in model.			11.2 Model outputs a best-case ground intercept.
6	Model allows for input of target population (e.g. 90% Male/10% Female).	6.1 Fraction male input option in model.	12	Model predicts the expected (8th) accommodation of driver: selected seat positions relative to the accelerator heel point (AHP) if the seat travel is censored.	12.1 Model outputs a censored seat travel that adjusts with model inputs.
		6.2 Target accommodation input option in model.			12.2 TARDEC CAD model matches the UNTRI spreadsheet.

Boundary Manikin Placement

#	M&S Requirement	Acceptability Criteria	Metrics/Measures
1	Model predicts the location of the hip with respect to the AHP.	1.1 Model outputs the location of the hip with respect to the AHP that matches the UNTRI spreadsheet.	1.1 Representative (Pass) / Non-Representative (Fail)
		1.2 The manikin hip joint center aligns with the hip point.	1.2 Representative (Pass) / Non-Representative (Fail)
2	Model predicts the location of the eye with respect to the AHP.	2.1 Model outputs the location of the eye with respect to the AHP that matches the UNTRI spreadsheet.	2.1 Representative (Pass) / Non-Representative (Fail)
		2.2 The manikin eye aligns with the eye point.	2.2 Representative (Pass) / Non-Representative (Fail)

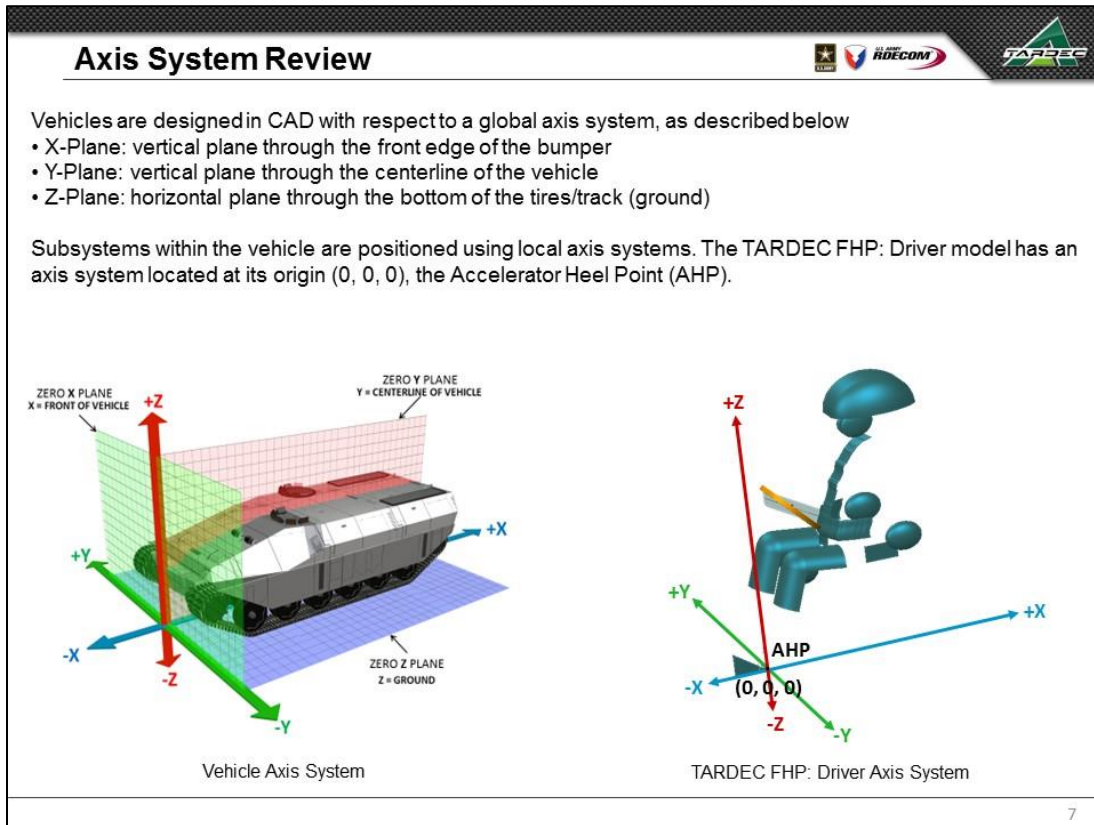

Model Inputs – Vehicle Description

Steering Wheel Point (SWP)
The effective center of the steering wheel, located at the intersection between the axis of rotation of the wheel and a plane lying on the driver side of the wheel. The SWP is reported in horizontal and vertical components with respect to the AHP.

Hydration Pack Relief Availability
Indicates the presence of an opening in the seat back that fully accommodates a donned hydration pack, such that the occupant's position in the seat would be the same with or without the hydration pack.

Human Accommodation Reference Point (HARP) Measurement Tool
HARP is a seat reference from which sitter hip locations and other aspects of posture can be calculated. Both the SAE J826 H-point manikin and the ISO 5353 SIP Tool can be used.



SAE J826 H-point Manikin



ISO 5353 SIP Tool

8

Model Inputs – Target Design Population

Fraction Male
The expected percentage of males in the defined target design population.

Ensemble
The clothing and equipment that will be worn. The following ensembles are available in the model:

- Personal Protective Equipment (PPE)
PPE includes the Advanced Combat Uniform (ACU), Improved Outer Tactical Vest (IOTV) and Advanced Combat Helmet (ACH)
- Encumbered (ENC)
ENC includes all clothing and equipment in PPE plus a rifleman equipment kit as defined in UMTRI-2013-13



Personal Protective Equipment (PPE)



Encumbered (ENC)

Target Accommodation
The percentage of the defined target design population to be accommodated. Those not accommodated are evenly split between the smaller and larger extremes of the population. In MIL-STD-1472G, the accommodation target has been set at the central 90%.

9

<div style="display: flex; justify-content: space-between; align-items: center;"> Test Matrix  </div>							
Test #	Target Accommodation	Fraction Male	Ensemble	Steering Wheel Point (SWP) (measured wrt AHP)		Hydration Pack Relief Availability	HARP Measurement Tool
				X (in.) (L11, fore-aft)	Z (in.) (H17, vertical)		
1	90%	90%	PPE	8.9	30.9	No	SAE J826
2	90%	90%	PPE	14.8	30.9	No	SAE J826
3	90%	90%	PPE	13.3	29.0	No	ISO 5353
4	90%	90%	PPE	11.8	29.0	No	SAE J826
5	90%	90%	PPE	17.7	27.0	No	SAE J826
6	90%	90%	ACU	13.3	29.0	No	SAE J826
7	95%	90%	ENC	13.3	29.0	No	SAE J826
8	90%	50%	PPE	13.3	29.0	No	SAE J826
9	90%	50%	ACU	13.3	29.0	No	SAE J826
10	90%	50%	ENC	13.3	29.0	Yes	SAE J826

Note: Highlighted values differ from the previous test

Tests #1-6 primarily explore the effect of varying the Steering Wheel Point (SWP)

- Geometry and position for the Steering Wheel Preference Line and Steering Wheel Zone are constant
- Geometry for Seat Track Travel and composite body boundaries (except knees) is constant, but position varies
- Knee Boundary geometry and position are unique for each test to reflect changing shin and thigh angles
- Changing the HARP measurement tool only affects the position of Seat Track Travel

Test #7 primarily explores the effect of varying Target Accommodation

- Geometry for Seat Track Travel and composite body boundaries increase in volume with increased Target Accommodation

Tests #8-10 primarily explore the effects of using a different gender mix (Fraction Male) and varying the Ensemble

- Geometry for Seat Track Travel and composite body boundaries decrease in volume with a smaller proportion of males
- Position for Seat Track Travel and composite body boundaries vary with the chosen Ensemble

10

10.7.1 TEST #1 – BASELINE COMPARISON

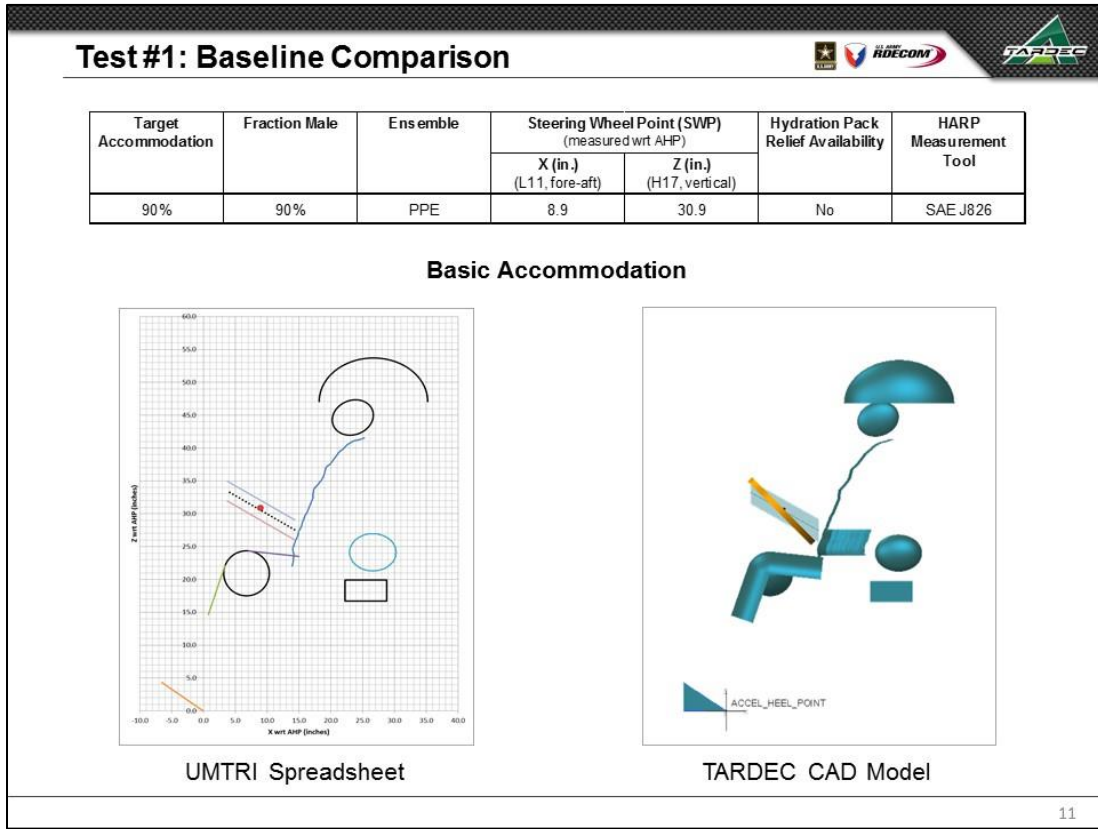

Surrogate Steering Wheel				Helmet Boundary			
	UMTRI Value	TARDEC Value	Difference		UMTRI Value	TARDEC Value	Difference
STEERING_WHEEL_X	8.900 in	8.900 in	0.000 in	HELMET_CONTOUR_CBTRD_X	26.684 in	26.684 in	0.000 in
STEERING_WHEEL_Z	30.900 in	30.900 in	0.000 in	HELMET_CONTOUR_CBTRD_Y (+/-)	2.185 in	2.185 in	0.000 in
Steering Wheel Preference Line				Knee Boundary			
	UMTRI Value	TARDEC Value	Difference		UMTRI Value	TARDEC Value	Difference
STRG_WHL_FWD_X	14.297 in	14.297 in	0.000 in	KNEE_CONTOUR_WEIGHTED_CENT_X	6.754 in	6.754 in	0.000 in
STRG_WHL_FWD_Z	27.559 in	27.559 in	0.000 in	KNEE_CONTOUR_WEIGHTED_CENT_Y (+/-)	7.582 in	7.582 in	0.000 in
STRG_WHL_RWD_X	3.733 in	3.733 in	0.000 in	KNEE_CONTOUR_WEIGHTED_CENT_Z	20.939 in	20.939 in	0.000 in
STRG_WHL_RWD_Z	33.465 in	33.465 in	0.000 in	KNEE_CONTOUR_X_AXIS_LENGTH	7.160 in	7.162 in	0.002 in
Steering Wheel Preference Zone				Elbow Boundary			
	UMTRI Value	TARDEC Value	Difference		UMTRI Value	TARDEC Value	Difference
STRG_WHL_ZONE_Z	1.516 in	1.516 in	0.001 in	ELBOW_WEIGHTED_CBNT_X	26.589 in	26.589 in	0.000 in
STRG_WHL_ZONE_Y	N/A	1.000 in	N/A	ELBOW_WEIGHTED_CBNT_Y (+/-)	12.353 in	12.353 in	0.000 in
Accelerator Plane Angle (APA)				Torso Boundary			
	UMTRI Value	TARDEC Value	Difference		UMTRI Value	TARDEC Value	Difference
ACCEL_PEDAL_PLANE_ANG	33.223 deg	33.223 deg	0.000 deg	TORSO_WEIGHTED_REF_PT_PPE_X	19.358 in	19.357 in	0.001 in
Origin (X)	0.000 in	0.000 in	0.000 in	TORSO_WEIGHTED_REF_PT_PPE_Z	35.595 in	35.595 in	0.000 in
Origin (Z)	0.000 in	0.000 in	0.000 in	Seat Track Travel Range			
BOFRP (X)	-6.587 in	-6.587 in	0.000 in				
BOFRP (Z)	4.314 in	4.314 in	0.000 in	SEAT_POSITION_CTR_OF_TRAVEL_X	25.490 in	25.491 in	0.001 in
Seat Back Angle				SEAT_POSITION_CTR_OF_TRAVEL_Z	18.292 in	18.292 in	0.000 in
	UMTRI Value	TARDEC Value	Difference	SEAT_POSITION_FORE_AFT_TRAVEL	6.539 in	6.539 in	0.001 in
SEAT_BACK_ANGLE_LOWER_QUANTILE	15.449 deg	15.449 deg	0.004 deg	SEAT_POSITION_VERTICAL_TRAVEL	3.222 in	3.223 in	0.001 in
SEAT_BACK_ANGLE_UPPER_QUANTILE	25.647 deg	25.650 deg	0.004 deg	Seat Back Angle			
Eyellipse					UMTRI Value	TARDEC Value	Difference
EYELLIPSE_CENTROID_X	23.440 in	23.440 in	0.000 in	SEAT_BACK_ANGLE_LOWER_QUANTILE	15.449 deg	15.449 deg	0.004 deg
EYELLIPSE_CENTROID_Y (+/-)	1.280 in	1.280 in	0.000 in	SEAT_BACK_ANGLE_UPPER_QUANTILE	25.647 deg	25.650 deg	0.004 deg
EYELLIPSE_CENTROID_Z	44.649 in	44.649 in	0.000 in	Eyellipse			
EYELLIPSE_ANGLE_REL_X	18.600 deg	18.600 deg	0.000 deg				
EYELLIPSE_X_AXIS_LENGTH	6.570 in	6.573 in	0.003 in	EYELLIPSE_CENTROID_X	23.440 in	23.440 in	0.000 in
EYELLIPSE_Y_AXIS_LENGTH	1.917 in	1.918 in	0.001 in	EYELLIPSE_CENTROID_Y (+/-)	1.280 in	1.280 in	0.000 in
EYELLIPSE_Z_AXIS_LENGTH	5.236 in	5.240 in	0.004 in	EYELLIPSE_CENTROID_Z	44.649 in	44.649 in	0.000 in

Values in agreement

12

Test #1: Surrogate Steering Wheel

A surrogate steering wheel is automatically positioned at the Steering Wheel Point (SWP). The geometry mimics the steering wheel used in the *Seated Soldier Study* driver mockup. The wheel has a 350 mm (13.78 in.) diameter and is angled at 45° from vertical.

Usage
 The surrogate steering wheel is provided for situations in which actual steering wheel geometry is not available.

UMTRI Spreadsheet Calculations

	L11	H17
	(in)	(in)
Steering Wheel Point (SWP)	8.900	30.900

TARDEC CAD Model Calculations

STEERING_WHEEL_X	8.900	in
STEERING_WHEEL_Z	30.900	in

TARDEC CAD Model Geometry

Side View

Steering Wheel Geometry

13

Test #1: Steering Wheel Preference Line



The steering wheel preference line depicts the preferred range of SWPs for the target driver population.

Usage
 The SWP should be adjusted to lie on or near this line.

UMTRI Spreadsheet Calculations

	L11 (in)	H17 (in)
Preference Line Endpoint, Min	14.297	27.559
Preference Line Endpoint, Max	3.733	33.465

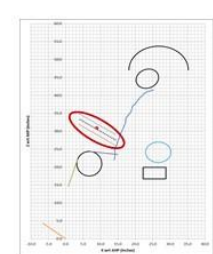

TARDEC CAD Model Calculations

STRG_WHL_FWD_X	14.297	in
STRG_WHL_FWD_Z	27.559	in
STRG_WHL_RWD_X	3.733	in
STRG_WHL_RWD_Z	33.465	in

TARDEC CAD Model Geometry

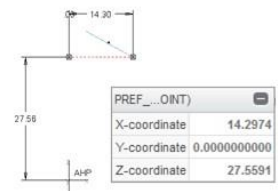

Preference Line Endpoint, Min

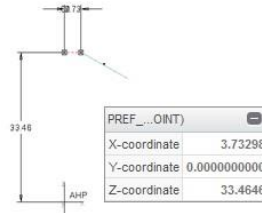

Preference Line Endpoint, Max

14

Test #1: Steering Wheel Preference Zone



The steering wheel preference zone depicts an acceptable range, beyond the steering wheel preference line, for positioning the SWP with respect to the target design population.

Usage
 The SWP should be located within the steering wheel preference zone.

UMTRI Spreadsheet Calculations

	L11 (in)	H17 (in)
Upper Rear	14.297	29.074 ←
Upper Front	3.733	34.980
Lower Rear	14.297	26.044 ←
Lower Front	3.733	31.949

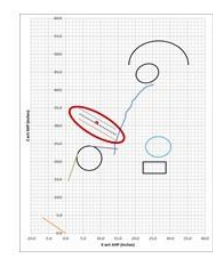

TARDEC CAD Model Calculations

STRG_WHL_ZONE_Z	1.516	in
STRG_WHL_ZONE_Y	1.000*	in

} These values represent half of the zone.

TARDEC CAD Model Geometry

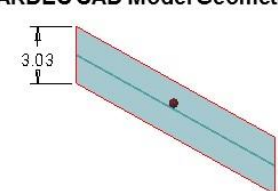

Side View

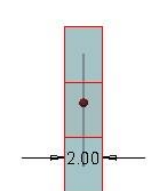

Rear View

↓ ↓

$29.074 \text{ in.} - 26.044 \text{ in.} = 3.030 \text{ in.}$

$\frac{1}{2} (3.030 \text{ in.}) = 1.515 \text{ in.}$

*Given value, not calculated

15

Test #1: Accelerator Plane Angle (APA)



The APA, calculated from the horizontal component of the SWP, is the theoretical angle at which a boot (with the heel positioned at the AHP) would contact the surface of the undeflected accelerator pedal.

Usage
 The APA, along with a 200 mm (7.87 in.) segment, is used to determine the position and orientation of the accelerator pedal. The segment represents the length of a boot from the AHP to the contact point on the accelerator pedal.

UMTRI Spreadsheet Calculations

Accelerator Plane Angle (APA)	33.223 deg	
	X (in)	Z (in)
Origin	0.000	0.000
BOFRP	-6.587	4.314

TARDEC CAD Model Calculations*

ACCEL_PEDAL_PLANE_ANG	33.223	deg
-----------------------	--------	-----

TARDEC CAD Model Geometry

End:Curve:F5	
X-coordinate	-6.58696
Y-coordinate	0.000000000
Z-coordinate	4.31417

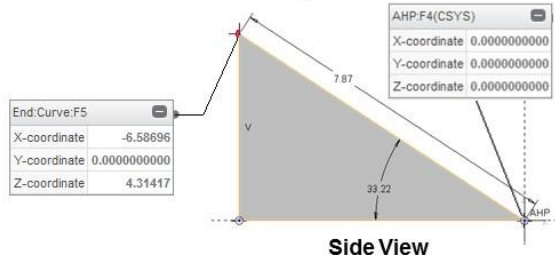

*Neither the Origin nor the BOFRP (the endpoints of the oriented boot segment) are calculated in CAD because they are not used to construct the geometry. Instead, a 200 mm segment, oriented to the calculated APA, is anchored to the AHP.

16

Test #1: Seat Track Travel Range



The seat track travel range represents the amount of seat track adjustment, located with respect to the AHP, needed to position individuals from the target design population to reach vehicle controls. The range is reported in terms of the chosen HARP measurement tool.

Usage
 Seats should be positioned in the vehicle environment such that the seat track travel window associated with the seat completely encompasses the seat track travel range calculated by the model.

UMTRI Spreadsheet Calculations

Center of Travel (X)	25.490	in
Center of Travel (Z)	18.292	in
Fore-Aft Travel (X)	6.535	in
Vertical Travel (Z)	3.222	in

TARDEC CAD Model Calculations

SEAT_POSITION_CTR_OF_TRAVEL_X	25.491	in
SEAT_POSITION_CTR_OF_TRAVEL_Z	18.292	in
SEAT_POSITION_FORE_AFT_TRAVEL	6.535	in
SEAT_POSITION_VERTICAL_TRAVEL	3.223	in

17

Test #1: Seat Track Travel Range (cont.)



TARDEC CAD Model Geometry
 The seat track travel range is represented in both the model geometry and annotated output.

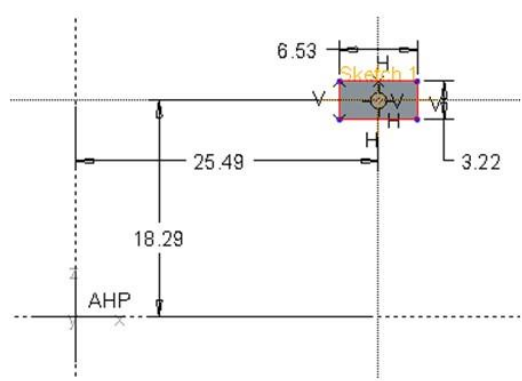

Side View

*** TARDEC™ Fixed Heel Point (FHP): Driver ***

Target Accommodation: 90.0 %

Population Description
 Fraction male: 90.0 %
 Ensemble: PPE (ACU + IOTV + Helmet (ACH))

Vehicle Description
 Steering Wheel Point, X (wrt AHP): 8.9 in.
 Steering Wheel Point, Z (wrt AHP): 30.9 in.

Consider hydration pack relief: FALSE

Calculated Seat Track Travel Range (Optimal)
 Fore-aft travel: 6.5 in.
 Vertical travel: 3.2 in.
 Centered, via SAE J826, @ (X = 25.5 in., Z = 18.3 in.)

Seat Back Angle (wrt vertical): 15.4° to 25.7°

Warnings
 -- Manikins with upper legs less than 5 deg above horiz
 #1 #2

18

Test #1 Bonus Feature: Censored Seat Track



In practice, it may not always be possible to position a seat so that its seat track travel completely encompasses the calculated seat track travel range. Instances of reduced seat track travel (censoring) can be quantified.

Usage
 The boundaries of the recommended seat track travel are modified to match what the seat hardware is capable of providing (given the seat's location in vehicle) so that the model can calculate a corrected level of seating accommodation.

TARDEC CAD Model Inputs

- Consider Censored Seating (Yes No)
- Seat Travel Reduction Front
- Seat Travel Reduction Rear
- Seat Travel Reduction Top
- Seat Travel Reduction Bottom

TARDEC CAD Model Geometry

Calculated Seat Track Travel Range (Censored)
 Fore-aft travel: 5.3 in.
 Vertical travel: 2.8 in.
 Centered, via SAE J826, @ (X = 25.1 in., Z = 18.3 in.)

Seat Track Travel Disaccommodation, Total
 Front: 3.3 % Top: 4.4 %
 Rear: 9.2 % Bottom: 4.4 %

Accommodation (Censored): 79.8 %

Warnings
 -- Accommodation geometry and manikin positions are not recalculated with censoring

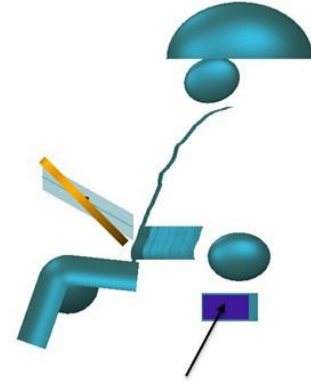

Reduced Seat Track Travel



19

Test #1: Seat Back Angle

The accommodation model assumes that the driver's seat also includes seat back angle adjustment. A range of seat back angles, measured from vertical, is calculated for the target design population.

Usage
 Along with seat track travel range, the seat back angle adjustment range should be considered when selecting vehicle seating.

UMTRI Spreadsheet Calculations

Front of Range	15.449 deg
Rear of Range	25.647 deg

TARDEC CAD Model Calculations

SEAT_BACK_ANGLE_LOWER_QUANTILE	15.445	deg
SEAT_BACK_ANGLE_UPPER_QUANTILE	25.650	deg

TARDEC CAD Model Geometry
 Seat back angle, though not represented geometrically, is reported in the annotated model output.

Calculated Seat Track Travel Range (Optimal)
 Fore-aft travel: 6.6 in.
 Vertical travel: 3.2 in.
 Centered, via SAE J826, @ (X = 25.5 in., Z = 18.3 in.)

Seat Back Angle (wrt vertical): 15.4^o to 25.7^o

Warnings
 -- Manikins with upper legs less than 5 deg above horiz
 #1 #2

20

Test #1: Eyellipse

The eyellipse (a contraction of the words "eye" and "ellipse") depicts the distribution of driver eye locations in the vehicle.

Usage
 The eyellipse is used to conduct vision analyses for the target design population.

UMTRI Spreadsheet Calculations

Eyellipse Centroids	X (in)	Y (in)	Z (in)
Right	23.440	1.280*	44.649
Left	23.440	-1.280*	44.649

Side View of Eyellipses (X, Z)

Eyellipse Angle (X' Axis wrt Horizontal)	18.600*	deg
Axis Length (X')	→ 6.570	in
Axis Length (Z')	→ 5.236	in

Rear View of Eyellipses (Y, Z)

Axis Length (Y)	→ 1.917	in
Axis Length (Z)	→ 5.387	in

TARDEC CAD Model Calculations

EYELLIPSE_CENTROID_X	23.440	in	
EYELLIPSE_SPACING_Y	2.559*	in	→ $\frac{1}{2} (2.559 \text{ in.}) = 1.280 \text{ in.}$
EYELLIPSE_CENTROID_Z	44.649	in	
EYELLIPSE_ANGLE_REL_X	18.600*	deg	
EYELLIPSE_X_AXIS_LENGTH	→ 6.573	in	
EYELLIPSE_Y_AXIS_LENGTH	→ 1.918	in	
EYELLIPSE_Z_AXIS_LENGTH	→ 5.240	in	

*Given value, not calculated

21

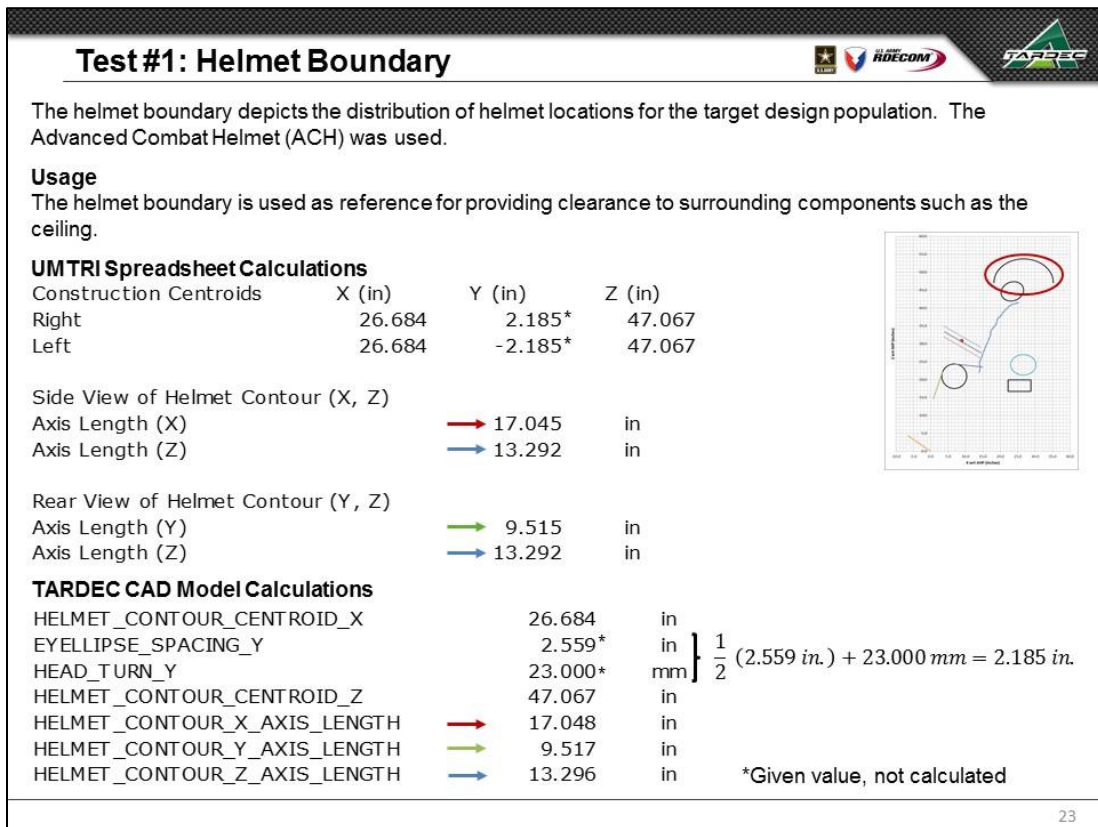
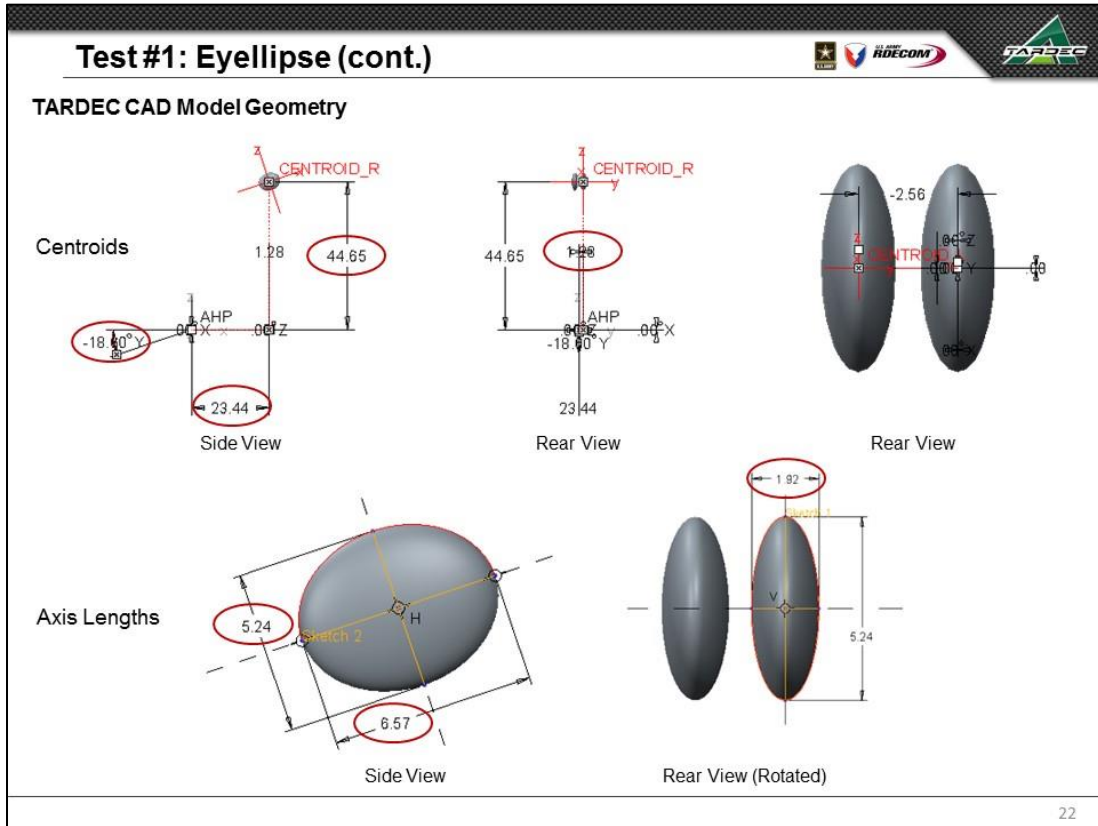

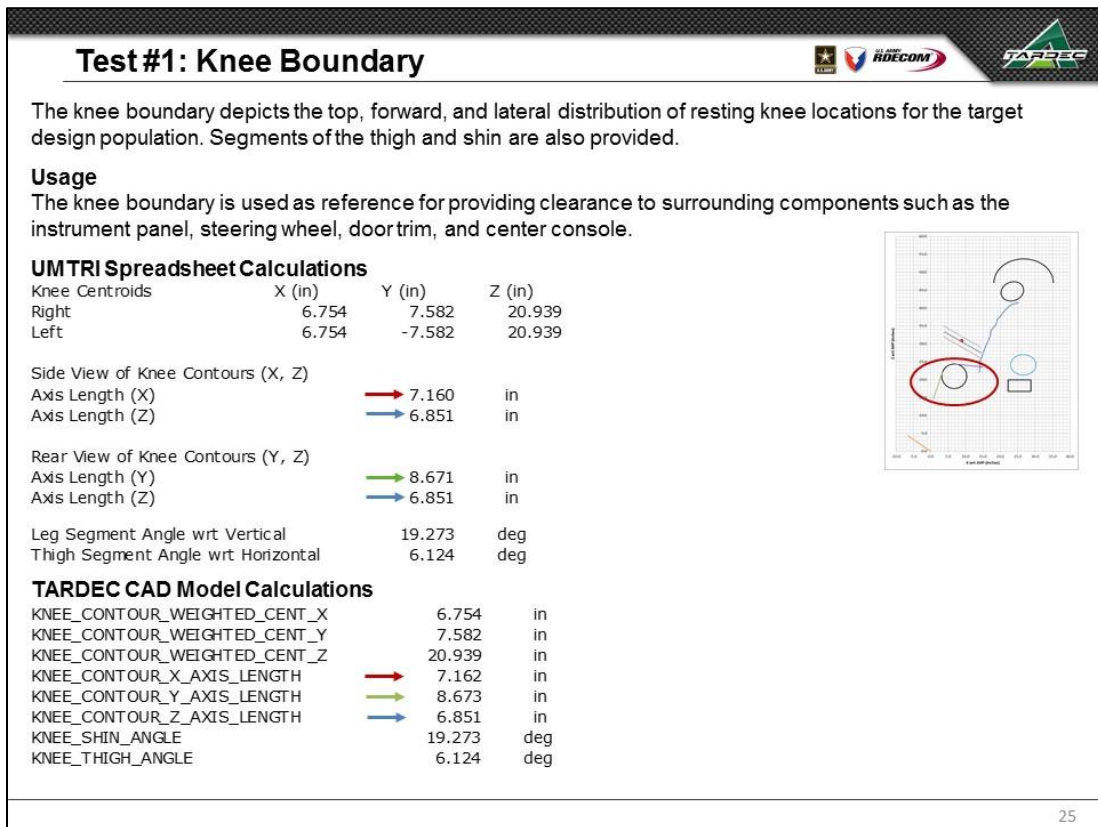
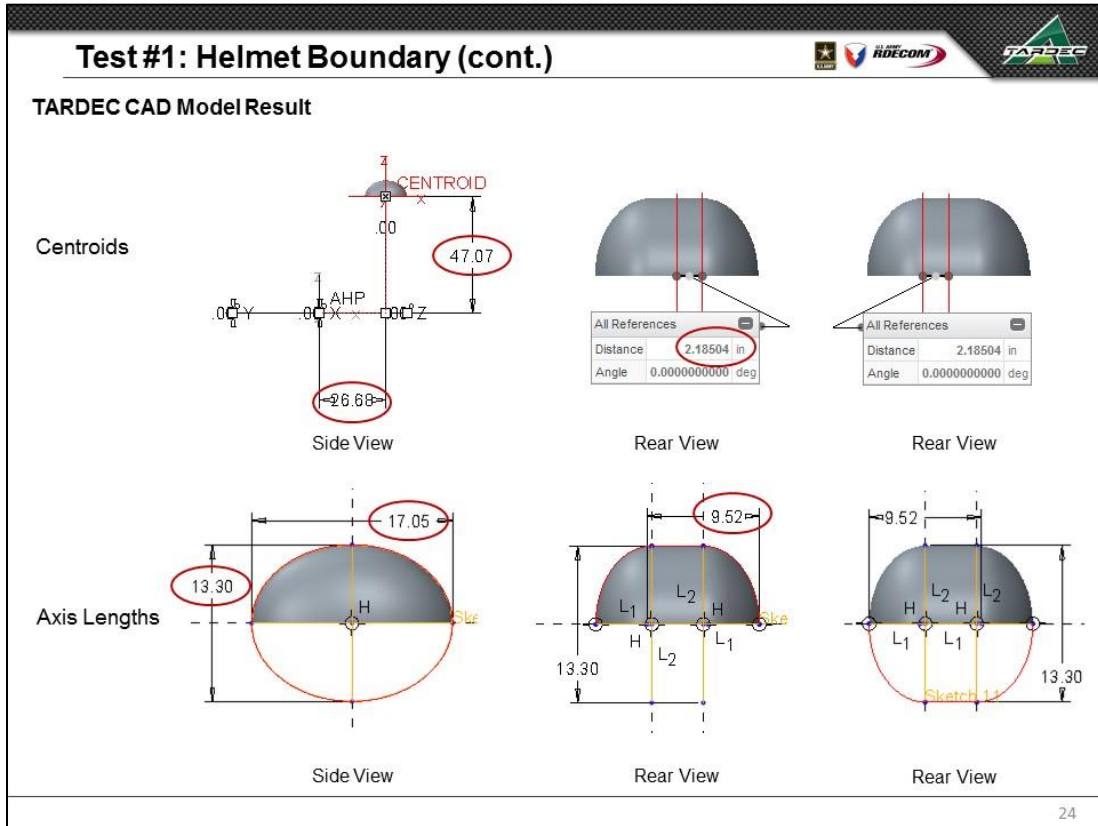

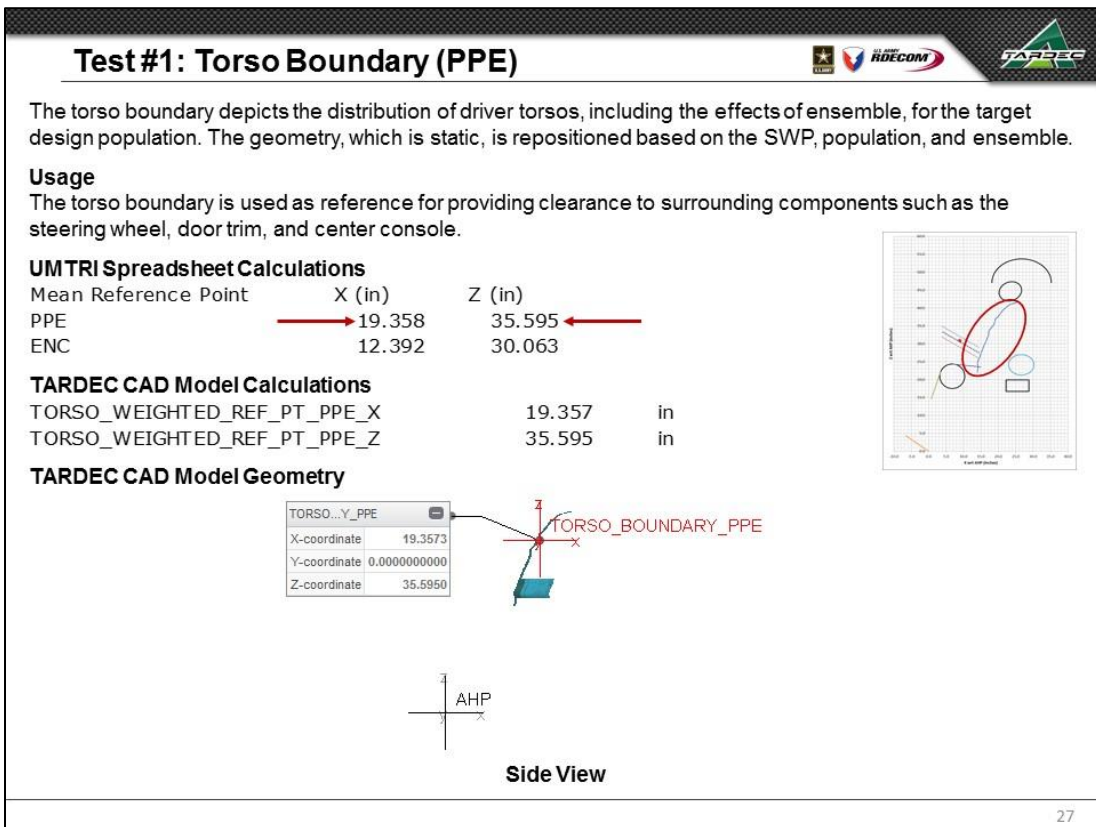
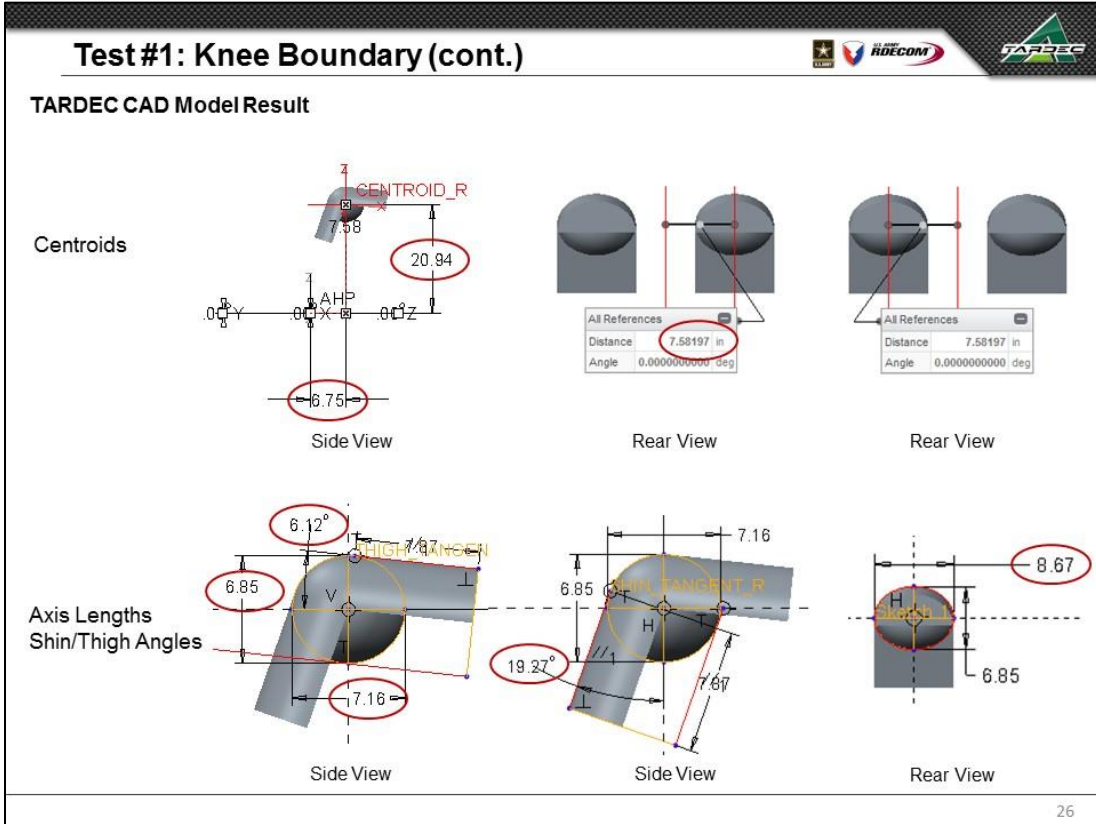

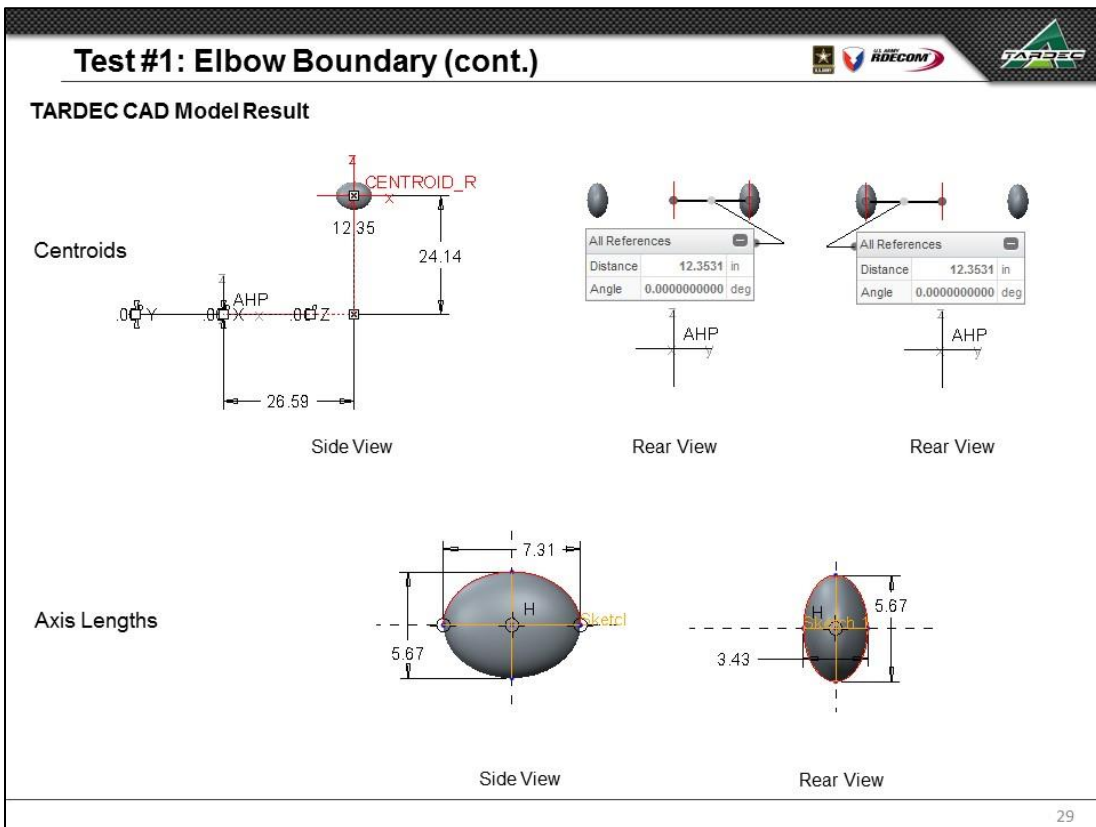
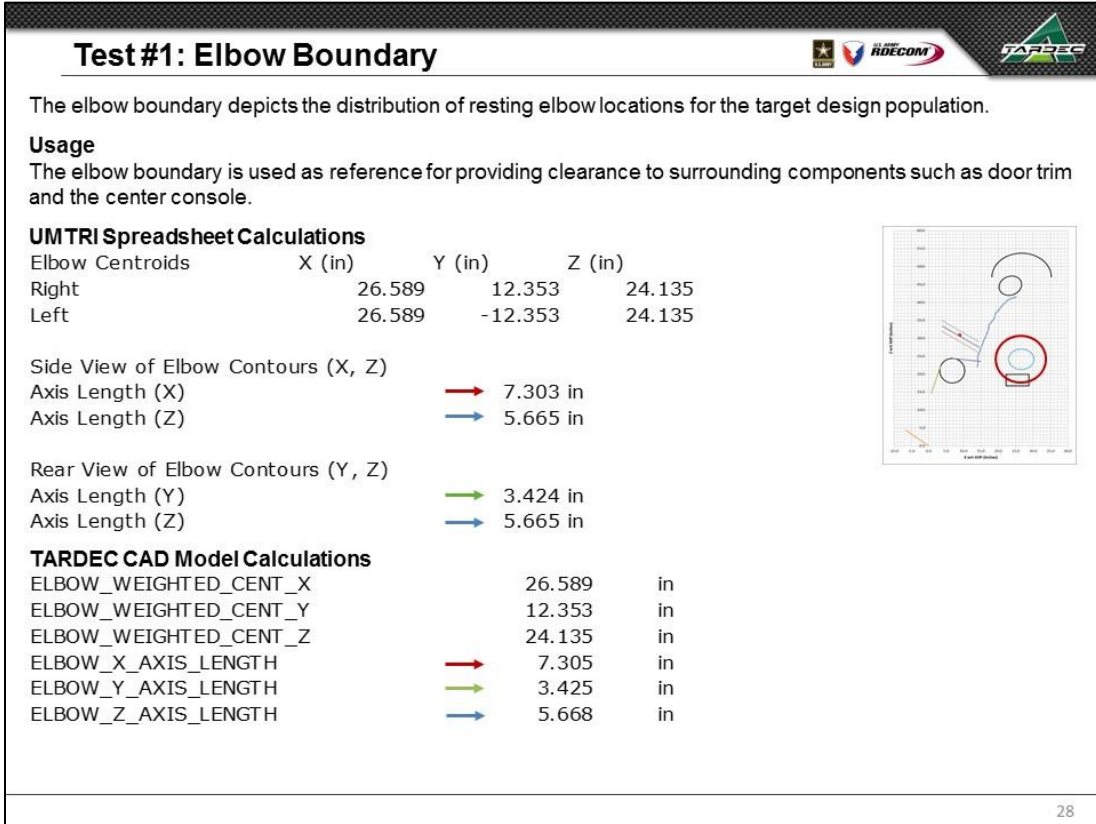

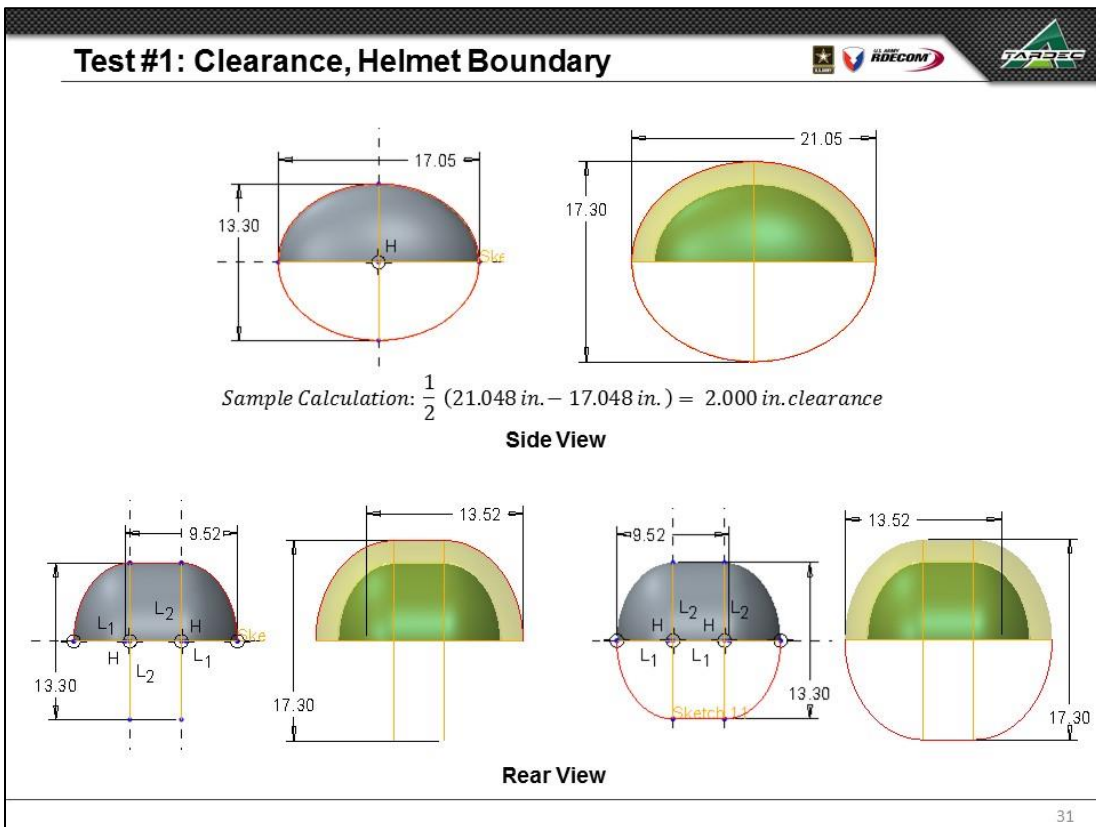
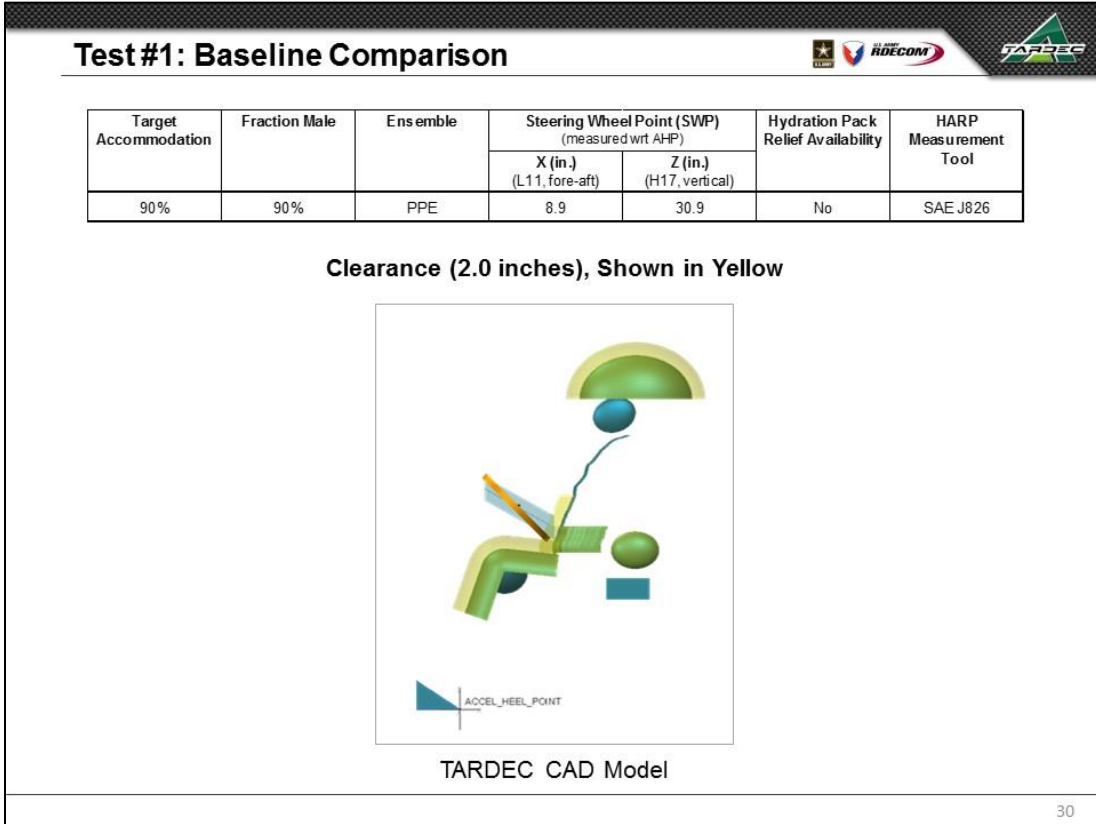

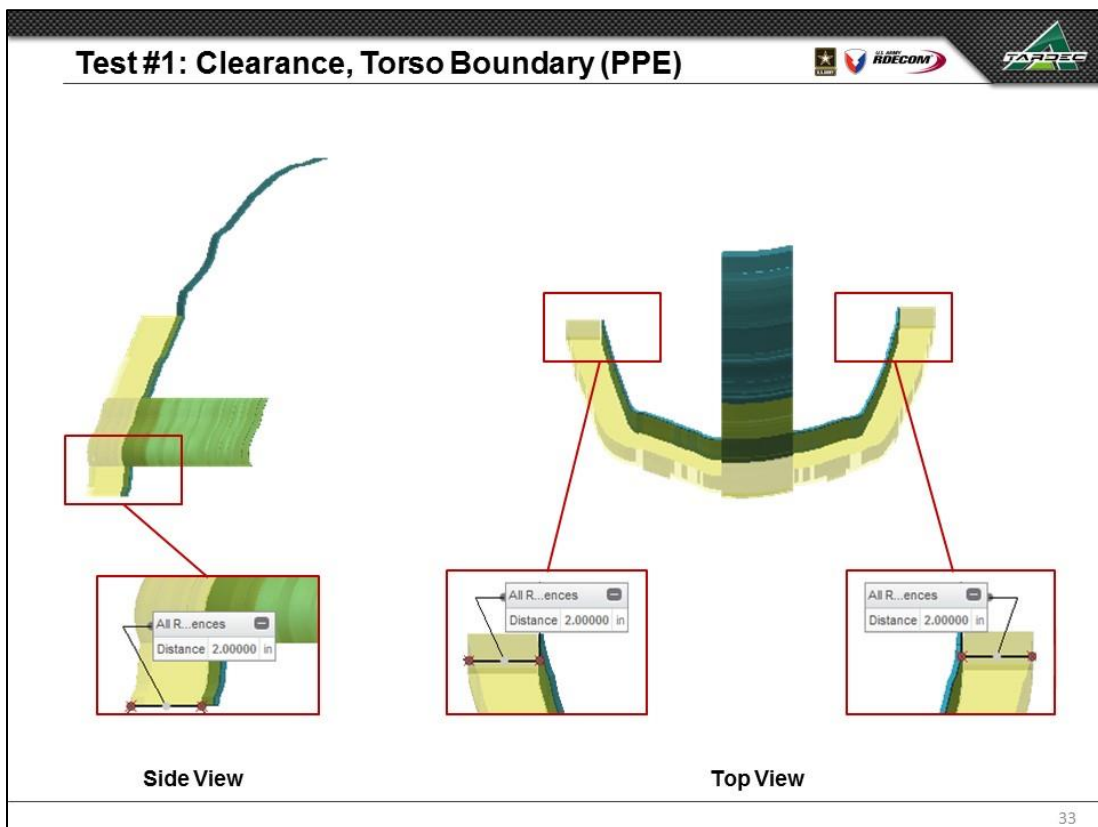
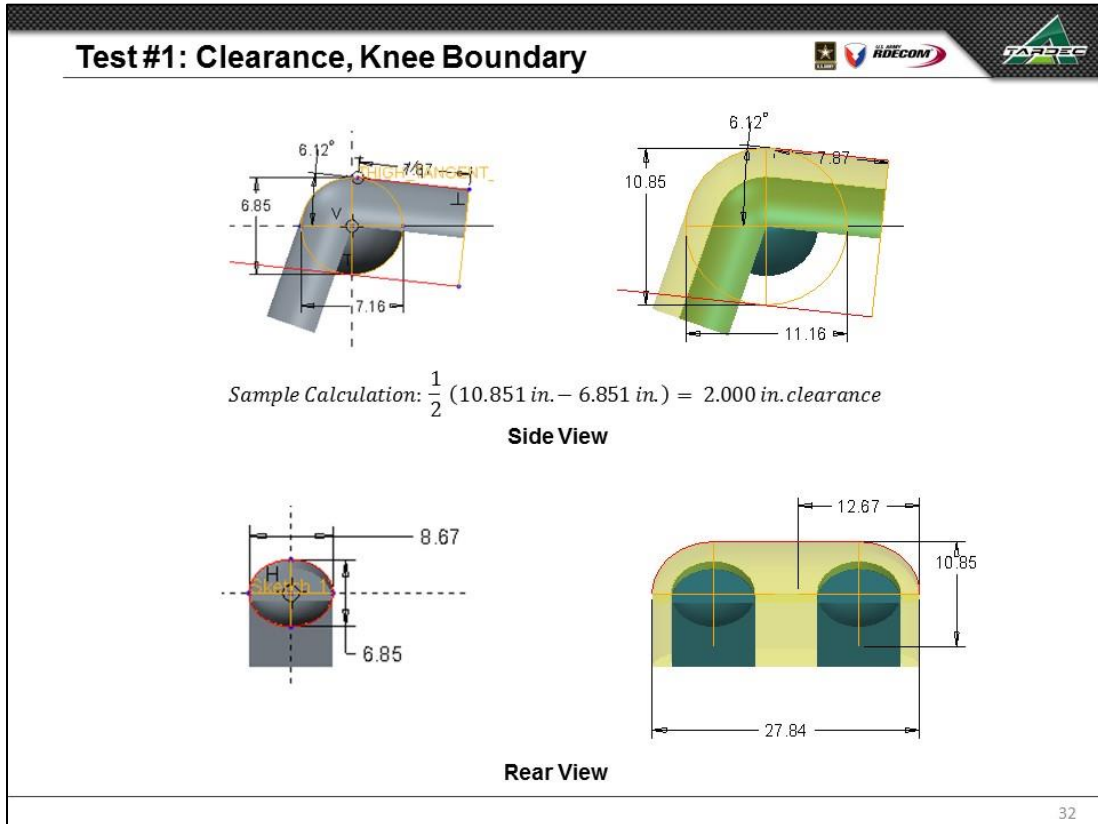

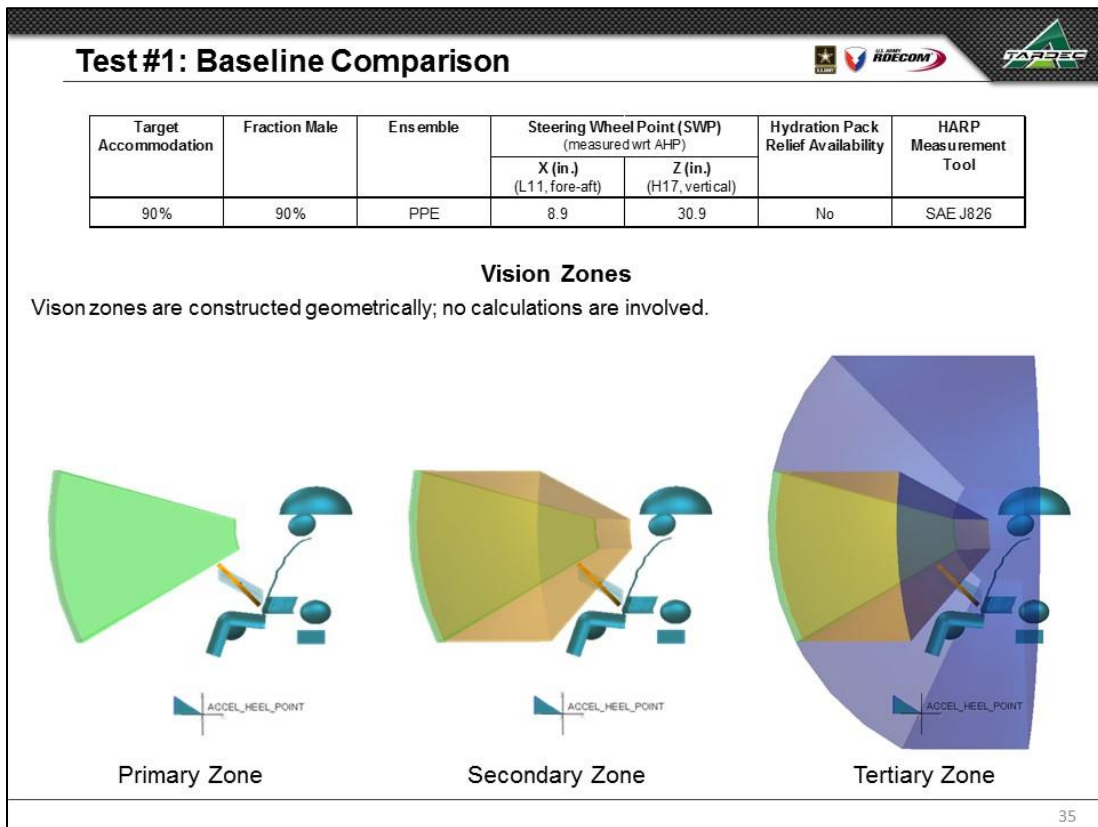
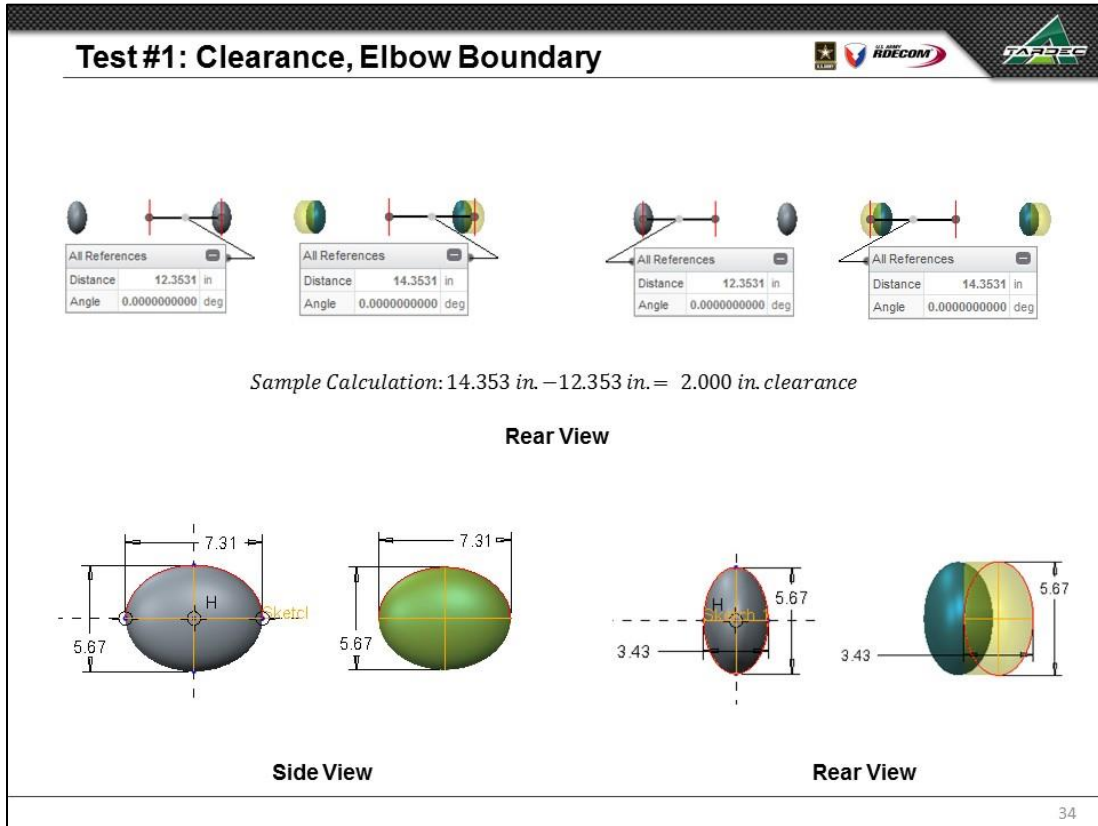



Test #1: Primary Vision Zone



The primary vision zone indicates a space viewable by all occupants using a minimum of easy rotation from at least one eye (ambinocular vision).

Usage
 Warning lights and displays are to be placed in the primary vision zone.

Zone Construction
 Combining the limits MIL-STD-1472 G and SAE J1050, easy eye rotation is defined laterally as 15 degrees side-to-side from the occupant's centerline and vertically as +15/-30 degrees from horizontal.

The effective viewing distance shall not be less than 13 inches.

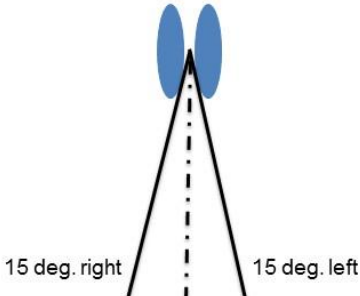

15 deg. right 15 deg. left

Intent

Top View





15.00°

CAD Implementation

36

Test #1: Primary Vision Zone (cont.)



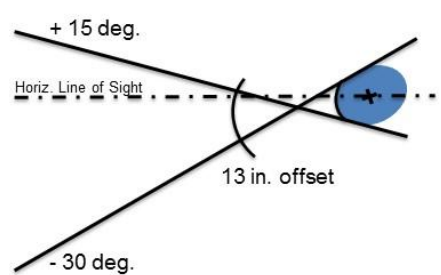

+ 15 deg.
Horiz. Line of Sight
13 in. offset
- 30 deg.

Intent

Side View



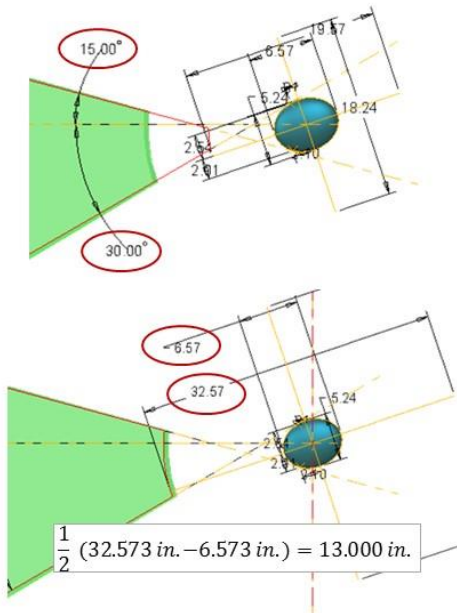

15.00°
30.00°
6.57
5.24
18.24
2.81
2.81
9.87
5.24
5.24

$\frac{1}{2} (32.573 \text{ in.} - 6.573 \text{ in.}) = 13.000 \text{ in.}$

CAD Implementation

37

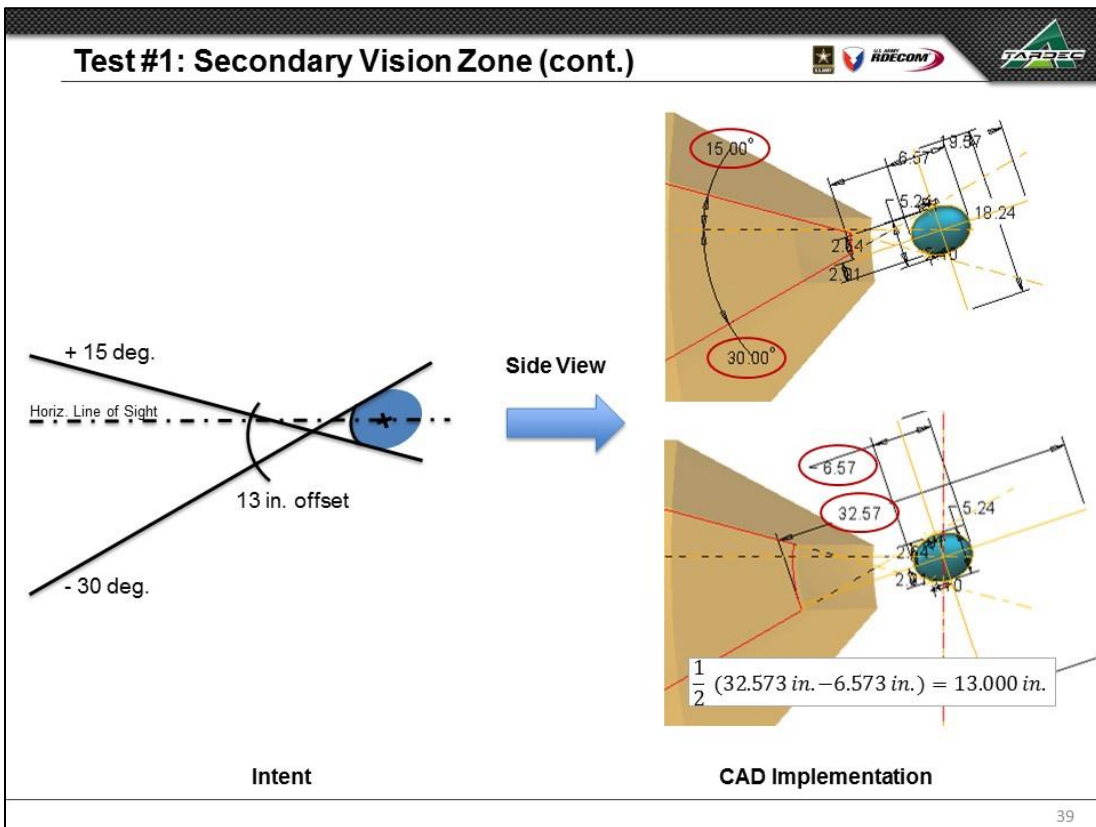
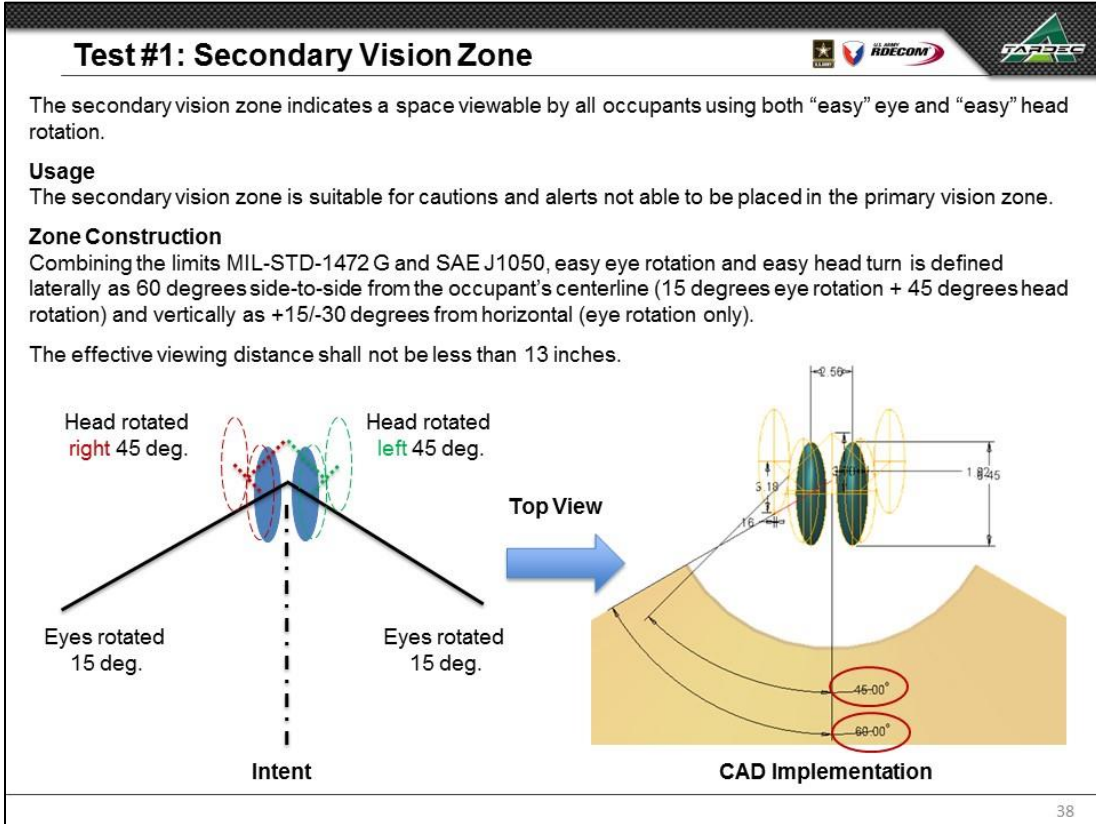

Test #1: Tertiary Vision Zone



The tertiary vision zone indicates a space viewable by all occupants using both maximum eye and maximum head rotation.

Usage
 The tertiary vision zone should only be used to place equipment needed for initial setup but not requiring attention while driving.

Zone Construction
 Combining the limits MIL-STD-1472 G and SAE J1050, maximum eye rotation and maximum head turn is defined laterally as 95 degrees side-to-side from the occupant's centerline (35 degrees eye + 60 degrees head) and vertically as +45 degrees/-65 degrees from horizontal (eye rotation only).

The effective viewing distance shall not be less than 13 inches.

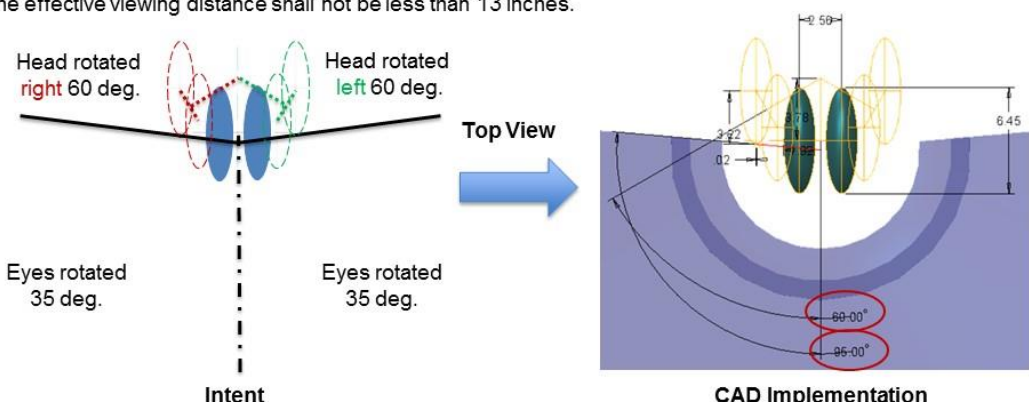

Top View

Head rotated right 60 deg. Head rotated left 60 deg.

Eyes rotated 35 deg. Eyes rotated 35 deg.

Intent

CAD Implementation

40

Test #1: Tertiary Vision Zone (cont.)



Side View

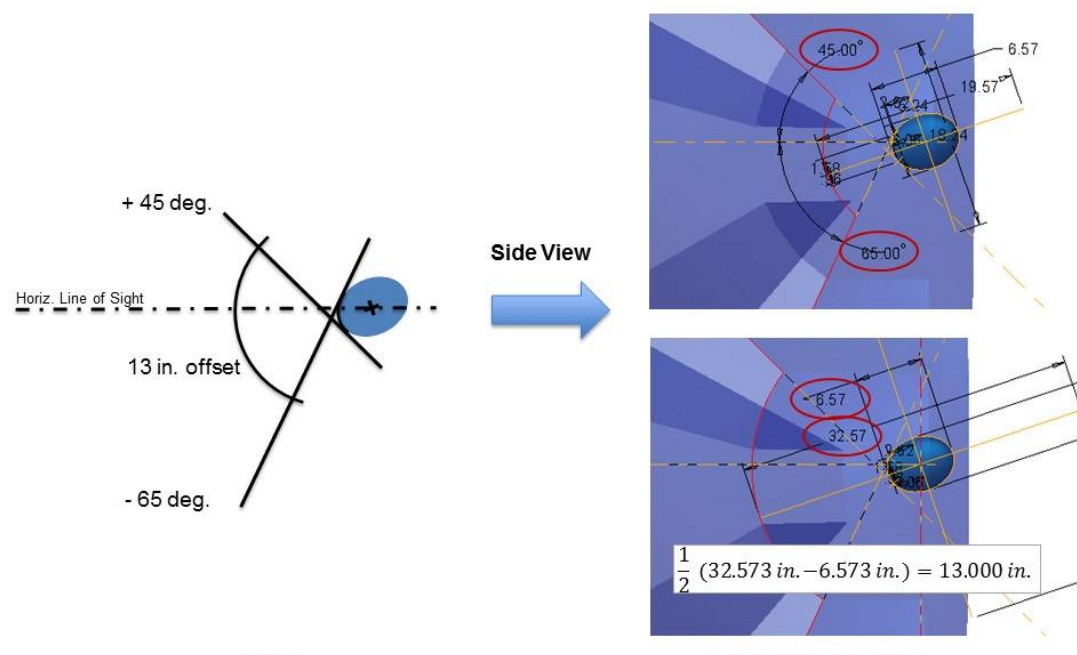

+ 45 deg.

Horiz. Line of Sight

13 in. offset

- 65 deg.

Intent

CAD Implementation

$\frac{1}{2} (32.573 \text{ in.} - 6.573 \text{ in.}) = 13.000 \text{ in.}$

41

Test #1 Bonus Feature: Ground Intercept



When the location of the occupant workspace is known with respect to the rest of the vehicle and the ground, the model is able to show the lowest line of sight in front of the driver to a desired ground intercept. It is depicted by a line tangent to the bottom of the eyellipse and through a user entered value for ground intercept.

Usage
 The ground intercept will remain visible by the target percentage of the population (e.g., 90%) as long as vehicle geometry remains below the Ground Intercept Line.

TARDEC CAD Model Inputs

- Consider Ground Intercept (Yes No)
- Minimum Ground Intercept
- Distance AHP to Vehicle FRT
- Distance AHP to Ground

TARDEC CAD Model Geometry

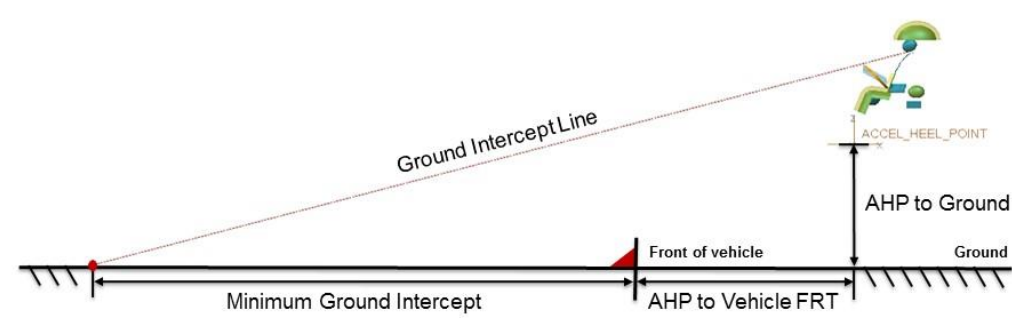

42

Test #1: Baseline Comparison



Target Accommodation	Fraction Male	Ensemble	Steering Wheel Point (SWP) (measured wrt AHP)		Hydration Pack Relief Availability	HARP Measurement Tool
			X (in.) (L11, fore-aft)	Z (in.) (H17, vertical)		
90%	90%	PPE	8.9	30.9	No	SAE J826

Boundary Manikin Posture and Position



TARDEC CAD Model

The 2015 Boundary Manikins are nominally positioned as follows:

- Hip and eye point locations, calculated using the same data underlying the creation of the accommodation boundaries, control manikin position
- Torso angles are calculated to allow manikins to simultaneously hold hip and eye points, using the following assumptions:
 - the torso is in a functional posture for driving
 - the head is held level
 - angle differences between the head and torso are evenly split between the top and bottom of the neck
- Leg angles are calculated such that the heels are on the AHP (in side view) and knees are played to the mean knee locations (by gender)
- Arm angles are calculated such that lower arms are parallel to ground, upper arms are perpendicular to lower arms, and elbows are played to the mean elbow locations (by gender)

43

Test #1: Boundary Manikin Positioning



Boundary manikins are positioned using hip and eye points calculated using equations from UMTRI's Excel spreadsheet "Seated Soldier Posture Prediction 2014-09-01".

Inputs

Vehicle Environment

- Steering Wheel Height (H17)
- Steering Wheel Fore-Aft (L11)

} SWP

Boundary Manikin Anthropometry

- Stature*
- Body Weight
- Erect Seating Height

Outputs

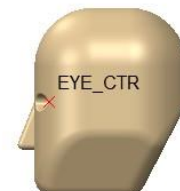
Hip Locator Coordinates Eye Locator Coordinates

Anthropometric values, used for all test cases, are as follows:

DHM #1 Small Overall Female Stature 1507 mm Body Weight 50.2 kg Erect Sitting Height 779 mm	DHM #4 Widest Shoulders Male Stature 1887 mm Body Weight 86.1 kg Erect Sitting Height 965 mm	DHM #7 large Overall Male Stature 1962 mm Body Weight 108 kg Erect Sitting Height 998 mm
DHM #2 Small Overall Male Stature 1643 mm Body Weight 66 kg Erect Sitting Height 842 mm	DHM #5 longest Torso Male Stature 1890 mm Body Weight 85.9 kg Erect Sitting Height 1004 mm	
DHM #3 Average Size Male Stature 1804 mm Body Weight 79.5 kg Erect Sitting Height 920 mm	DHM #6 Longest Legs Male Stature 1918 mm Body Weight 94.4 kg Erect Sitting Height 932 mm	

*Note: Values for stature include 1.5 inches representing boot heel thickness.

44

Test #1: Numerical Results, Manikin Positioning



Small Overall Female			
	UMTRI Value	TARDEC Value	Difference
POSTURE_DHM1_HIP_X	20.647 in	20.647 in	0.000 in
POSTURE_DHM1_HIP_Z	18.060 in	18.060 in	0.000 in
POSTURE_DHM1_EYE_X	21.622 in	21.622 in	0.000 in
POSTURE_DHM1_EYE_Z	40.128 in	40.128 in	0.000 in
Small Overall Male			
	UMTRI Value	TARDEC Value	Difference
POSTURE_DHM2_HIP_X	22.769 in	22.769 in	0.000 in
POSTURE_DHM2_HIP_Z	18.169 in	18.169 in	0.000 in
POSTURE_DHM2_EYE_X	22.873 in	22.873 in	0.000 in
POSTURE_DHM2_EYE_Z	41.895 in	41.895 in	0.000 in
Average Size Male			
	UMTRI Value	TARDEC Value	Difference
POSTURE_DHM3_HIP_X	24.965 in	24.965 in	0.000 in
POSTURE_DHM3_HIP_Z	18.169 in	18.169 in	0.000 in
POSTURE_DHM3_EYE_X	24.282 in	24.282 in	0.000 in
POSTURE_DHM3_EYE_Z	44.119 in	44.119 in	0.000 in
Widest Shoulders Male			
	UMTRI Value	TARDEC Value	Difference
POSTURE_DHM4_HIP_X	25.973 in	25.973 in	0.000 in
POSTURE_DHM4_HIP_Z	18.157 in	18.157 in	0.000 in
POSTURE_DHM4_EYE_X	24.938 in	24.938 in	0.000 in
POSTURE_DHM4_EYE_Z	45.397 in	45.397 in	0.000 in
Longest Torso Male			
	UMTRI Value	TARDEC Value	Difference
POSTURE_DHM5_HIP_X	25.216 in	25.216 in	0.000 in
POSTURE_DHM5_HIP_Z	18.151 in	18.151 in	0.000 in
POSTURE_DHM5_EYE_X	24.448 in	24.448 in	0.000 in
POSTURE_DHM5_EYE_Z	46.398 in	46.398 in	0.000 in
Longest Legs Male			
	UMTRI Value	TARDEC Value	Difference
POSTURE_DHM6_HIP_X	27.489 in	27.489 in	0.000 in
POSTURE_DHM6_HIP_Z	18.222 in	18.222 in	0.000 in
POSTURE_DHM6_EYE_X	25.858 in	25.858 in	0.000 in
POSTURE_DHM6_EYE_Z	44.618 in	44.618 in	0.000 in
Large Overall Male			
	UMTRI Value	TARDEC Value	Difference
POSTURE_DHM7_HIP_X	27.314 in	27.314 in	0.000 in
POSTURE_DHM7_HIP_Z	18.320 in	18.320 in	0.000 in
POSTURE_DHM7_EYE_X	25.638 in	25.638 in	0.000 in
POSTURE_DHM7_EYE_Z	46.357 in	46.357 in	0.000 in

TARDEC CAD values to agree with UMTRI spreadsheet values within
 ±0.100 inches
 ±0.100 degrees

Largest Observed Differences:
 0.000 inches

Values in agreement

45

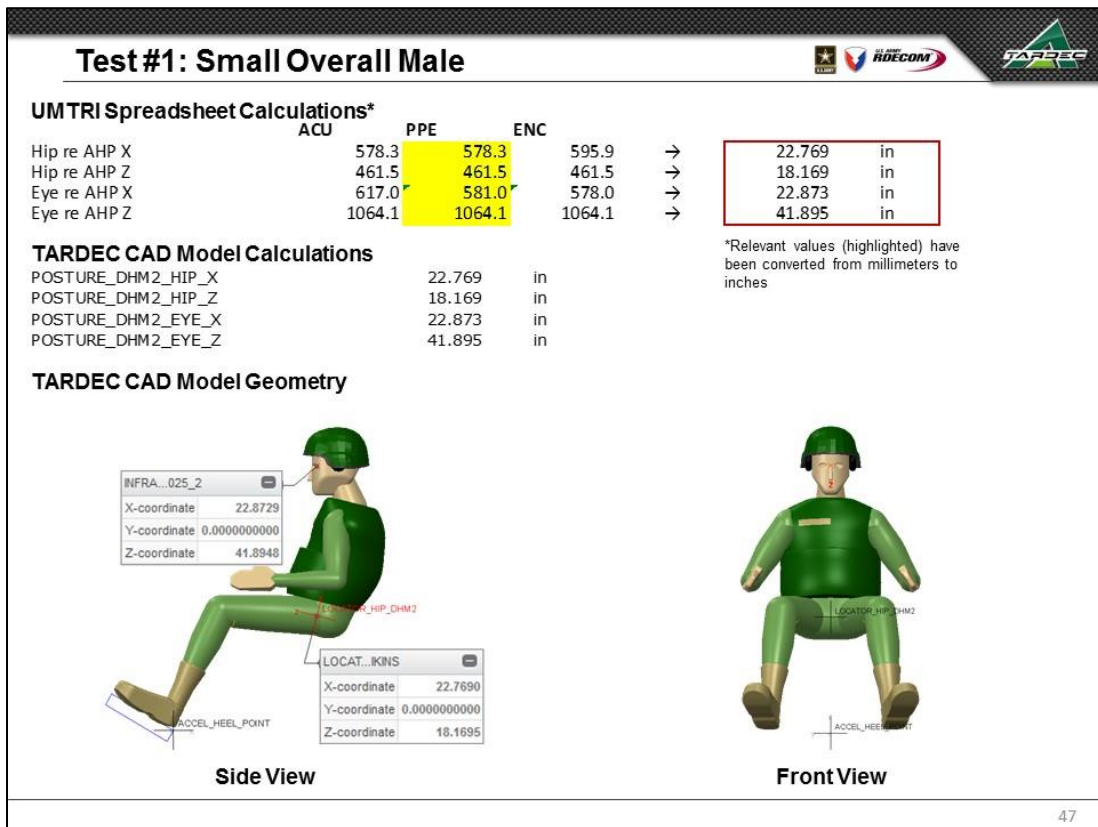
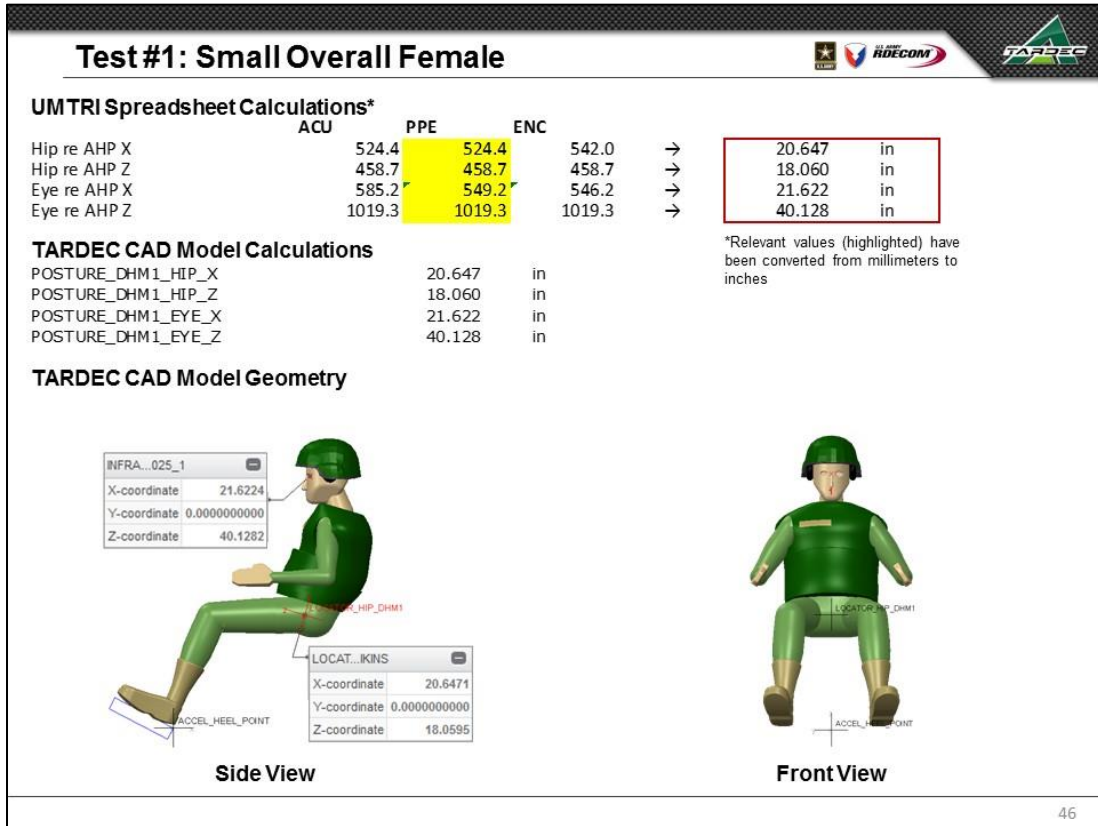

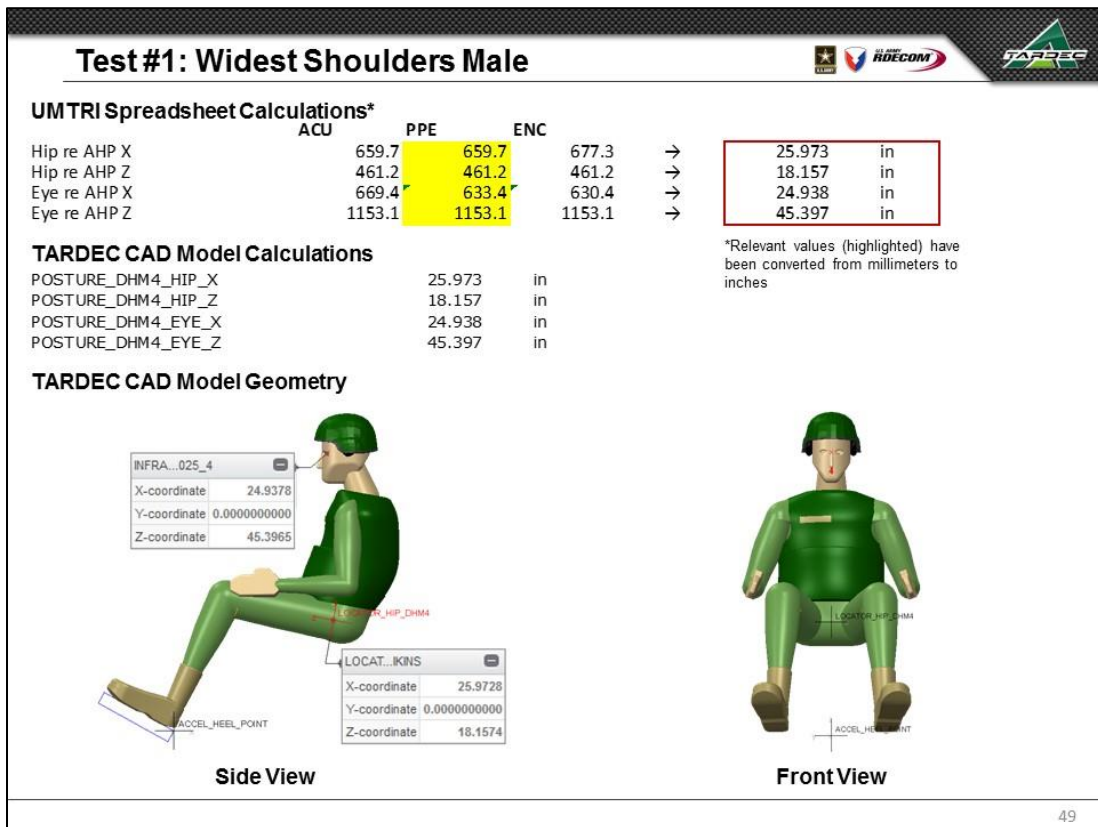
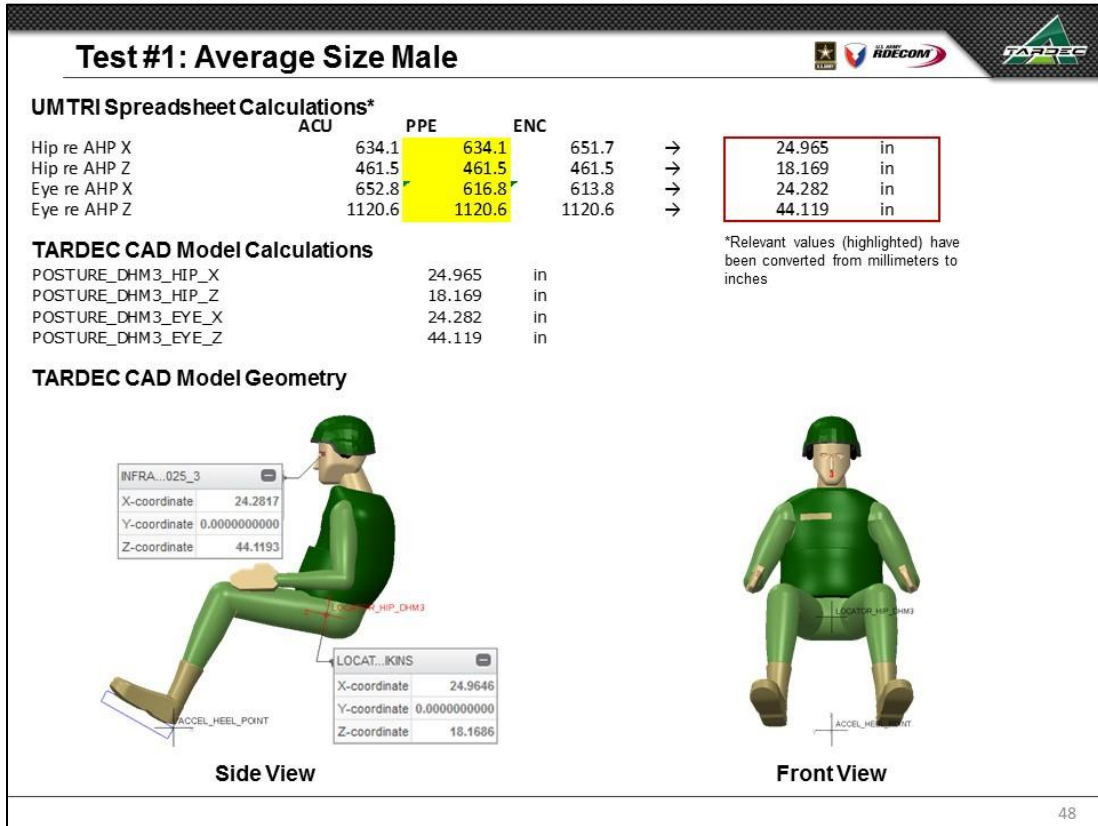

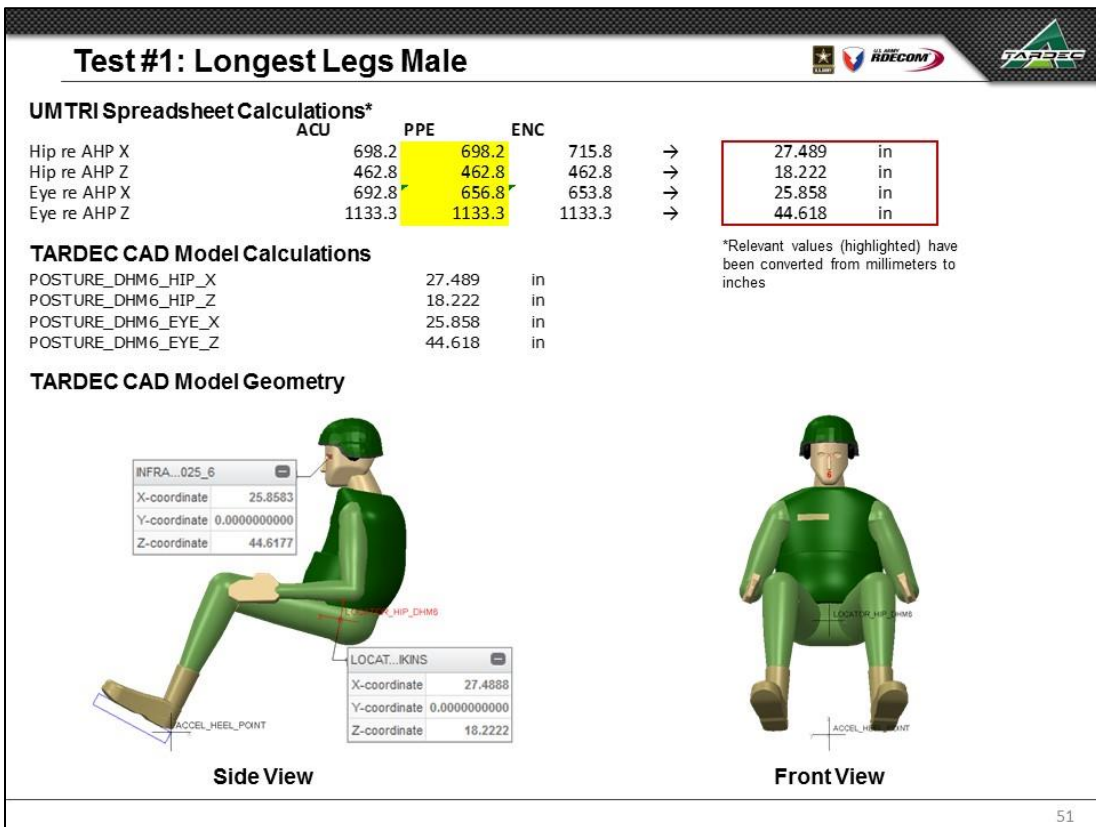
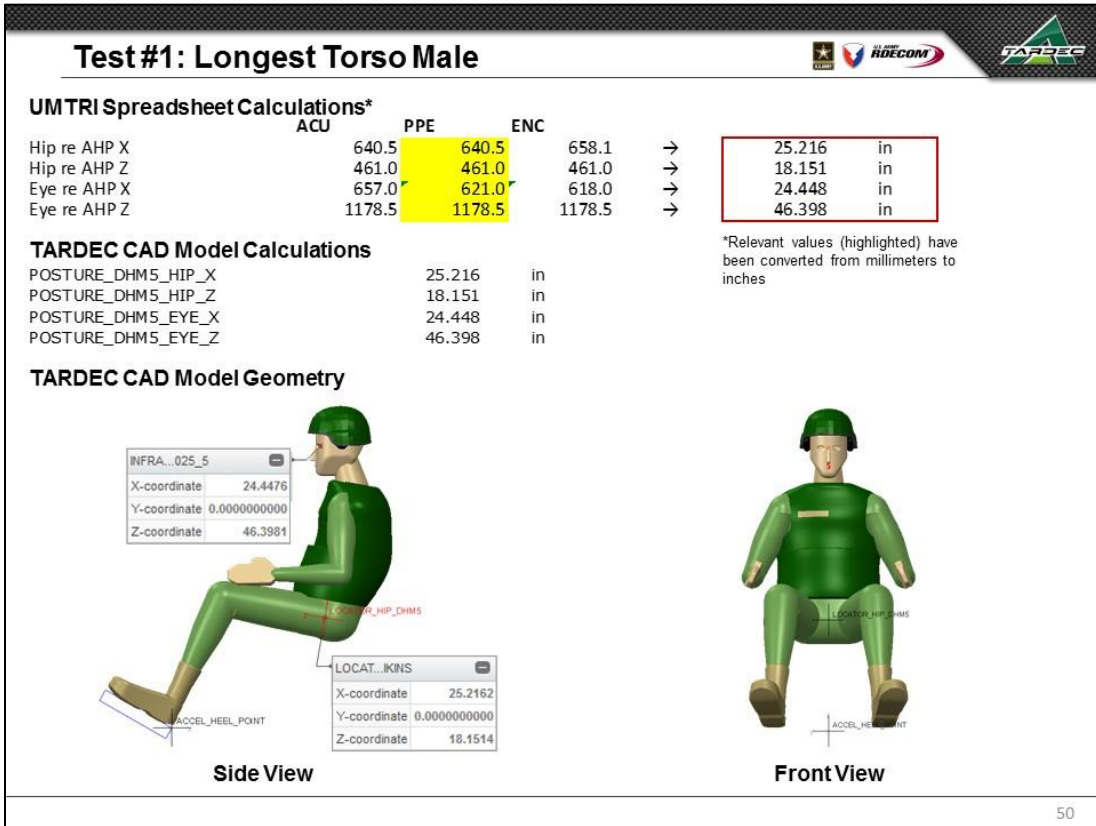

Test #1: Large Overall Male



UMTRI Spreadsheet Calculations*

	ACU	PPE	ENC		
Hip re AHP X	693.8	693.8	711.4	→	27.314 in
Hip re AHP Z	465.3	465.3	465.3	→	18.320 in
Eye re AHP X	687.1	651.1	648.1	→	25.635 in
Eye re AHP Z	1177.5	1177.5	1177.5	→	46.357 in

TARDEC CAD Model Calculations

POSTURE_DHM7_HIP_X	27.314	in
POSTURE_DHM7_HIP_Z	18.320	in
POSTURE_DHM7_EYE_X	25.635	in
POSTURE_DHM7_EYE_Z	46.357	in

*Relevant values (highlighted) have been converted from millimeters to inches

TARDEC CAD Model Geometry



Side View



Front View

52

10.7.2 TEST #2 – VARY STEERING WHEEL POINT IN FORE-AFT (X) DIRECTION

Test #2: Vary Steering Wheel Point (SWP)



Target Accommodation	Fraction Male	Ensemble	Steering Wheel Point (SWP) (measured wrt AHP)		Hydration Pack Relief Availability	HARP Measurement Tool
			X (in.) (L11, fore-aft)	Z (in.) (H17, vertical)		
90%	90%	PPE	14.8	30.9	No	SAE J826

Basic Accommodation

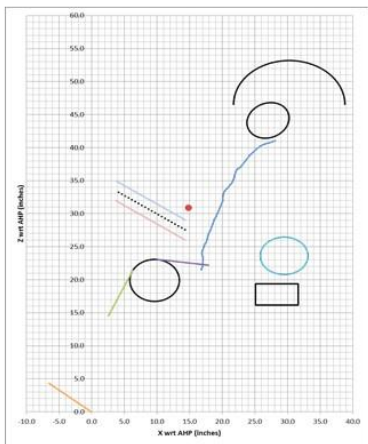

UMTRI Spreadsheet



TARDEC CAD Model

53

Test #2: Numerical Results, Accommodation

Surrogate Steering Wheel			
	UMTRI Value	TARDEC Value	Difference
STEERING_WHEEL_X	14.800 in	14.800 in	0.000 in
STEERING_WHEEL_Z	30.900 in	30.900 in	0.000 in
Steering Wheel Preference Line			
	UMTRI Value	TARDEC Value	Difference
STRG_WHL_FWD_X	14.297 in	14.297 in	0.000 in
STRG_WHL_FWD_Z	27.559 in	27.559 in	0.000 in
STRG_WHL_RWD_X	3.733 in	3.733 in	0.000 in
STRG_WHL_RWD_Z	33.465 in	33.465 in	0.000 in
Steering Wheel Preference Zone			
	UMTRI Value	TARDEC Value	Difference
STRG_WHL_ZONE_Z	1.516 in	1.516 in	0.001 in
STRG_WHL_ZONE_Y	N/A	1.000 in	N/A
Accelerator Plane Angle (APA)			
	UMTRI Value	TARDEC Value	Difference
ACCEL_PEDAL_PLANE_ANG	33.223 deg	33.223 deg	0.000 deg
Origin (X)	0.000 in	0.000 in	0.000 in
Origin (Z)	0.000 in	0.000 in	0.000 in
BOFRP (X)	-6.587 in	-6.587 in	0.000 in
BOFRP (Z)	4.314 in	4.314 in	0.000 in
Seat Track Travel Range			
	UMTRI Value	TARDEC Value	Difference
SEAT_POSITION_CTR_OF_TRAVEL_X	28.363 in	28.364 in	0.001 in
SEAT_POSITION_CTR_OF_TRAVEL_Z	17.767 in	17.767 in	0.000 in
SEAT_POSITION_FORE_AFT_TRAVEL	6.539 in	6.535 in	0.001 in
SEAT_POSITION_VERTICAL_TRAVEL	3.223 in	3.223 in	0.001 in
Seat Back Angle			
	UMTRI Value	TARDEC Value	Difference
SEAT_BACK_ANGLE_LOWER_QUANTILE	16.872 deg	16.868 deg	0.004 deg
SEAT_BACK_ANGLE_UPPER_QUANTILE	27.070 deg	27.074 deg	0.004 deg
Eyellipse			
	UMTRI Value	TARDEC Value	Difference
EYELLIPSE_CENTROID_X	26.998 in	26.998 in	0.000 in
EYELLIPSE_CENTROID_Y (+/-)	1.280 in	1.280 in	0.000 in
EYELLIPSE_CENTROID_Z	44.124 in	44.124 in	0.000 in
EYELLIPSE_ANGLE_REL_X	18.600 deg	18.600 deg	0.000 deg
EYELLIPSE_X_AXIS_LENGTH	6.570 in	6.573 in	0.003 in
EYELLIPSE_Y_AXIS_LENGTH	1.917 in	1.918 in	0.001 in
EYELLIPSE_Z_AXIS_LENGTH	5.236 in	5.240 in	0.004 in

Helmet Boundary			
	UMTRI Value	TARDEC Value	Difference
HELMET_CONTOUR_CBTRDROID_X	30.242 in	30.242 in	0.000 in
HELMET_CONTOUR_CBTRDROID_Y (+/-)	2.185 in	2.185 in	0.000 in
HELMET_CONTOUR_CBTRDROID_Z	46.542 in	46.542 in	0.000 in
HELMET_CONTOUR_X_AXIS_LENGTH	17.045 in	17.048 in	0.003 in
HELMET_CONTOUR_Y_AXIS_LENGTH	9.515 in	9.517 in	0.001 in
HELMET_CONTOUR_Z_AXIS_LENGTH	13.292 in	13.296 in	0.004 in
Knee Boundary			
	UMTRI Value	TARDEC Value	Difference
KNEE_CONTOUR_WEIGHTED_CENT_X	9.627 in	9.627 in	0.000 in
KNEE_CONTOUR_WEIGHTED_CENT_Y (+/-)	7.085 in	7.085 in	0.000 in
KNEE_CONTOUR_WEIGHTED_CENT_Z	19.897 in	19.897 in	0.000 in
KNEE_CONTOUR_X_AXIS_LENGTH	7.587 in	7.589 in	0.002 in
KNEE_CONTOUR_Y_AXIS_LENGTH	8.671 in	8.673 in	0.001 in
KNEE_CONTOUR_Z_AXIS_LENGTH	6.350 in	6.350 in	0.000 in
KNEE_SHIN_ANGLE	28.445 deg	28.445 deg	0.000 deg
KNEE_THIGH_ANGLE	6.124 deg	6.124 deg	0.000 deg
Torso Boundary			
	UMTRI Value	TARDEC Value	Difference
TORSO_WEIGHTED_REF_PT_PFE_X	22.231 in	22.231 in	0.001 in
TORSO_WEIGHTED_REF_PT_PFE_Z	35.070 in	35.070 in	0.000 in
Elbow Boundary			
	UMTRI Value	TARDEC Value	Difference
ELBOW_WEIGHTED_CBNT_X	29.463 in	29.463 in	0.000 in
ELBOW_WEIGHTED_CBNT_Y (+/-)	12.353 in	12.353 in	0.000 in
ELBOW_WEIGHTED_CBNT_Z	23.610 in	23.610 in	0.000 in
ELBOW_X_AXIS_LENGTH	7.303 in	7.305 in	0.002 in
ELBOW_Y_AXIS_LENGTH	3.424 in	3.425 in	0.001 in
ELBOW_Z_AXIS_LENGTH	5.665 in	5.668 in	0.003 in

TARDEC CAD values to agree with UMTRI spreadsheet values within
 ±0.100 inches
 ±0.100 degrees

Largest Observed Differences:
 0.004 inches
 0.004 degrees

Values in agreement

54

Test #2: Surrogate Steering Wheel

UMTRI Spreadsheet Calculations

	L11	H17
	(in)	(in)
Steering Wheel Point (SWP)	14.800	30.900

TARDEC CAD Model Calculations

STEERING_WHEEL_X	14.800	in
STEERING_WHEEL_Z	30.900	in

TARDEC CAD Model Geometry

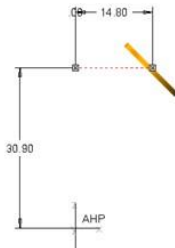

Side View

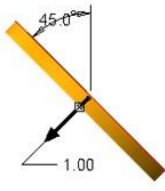

Side View

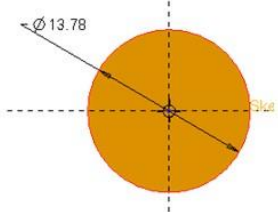

Normal to Steering Wheel

Steering Wheel Geometry

55

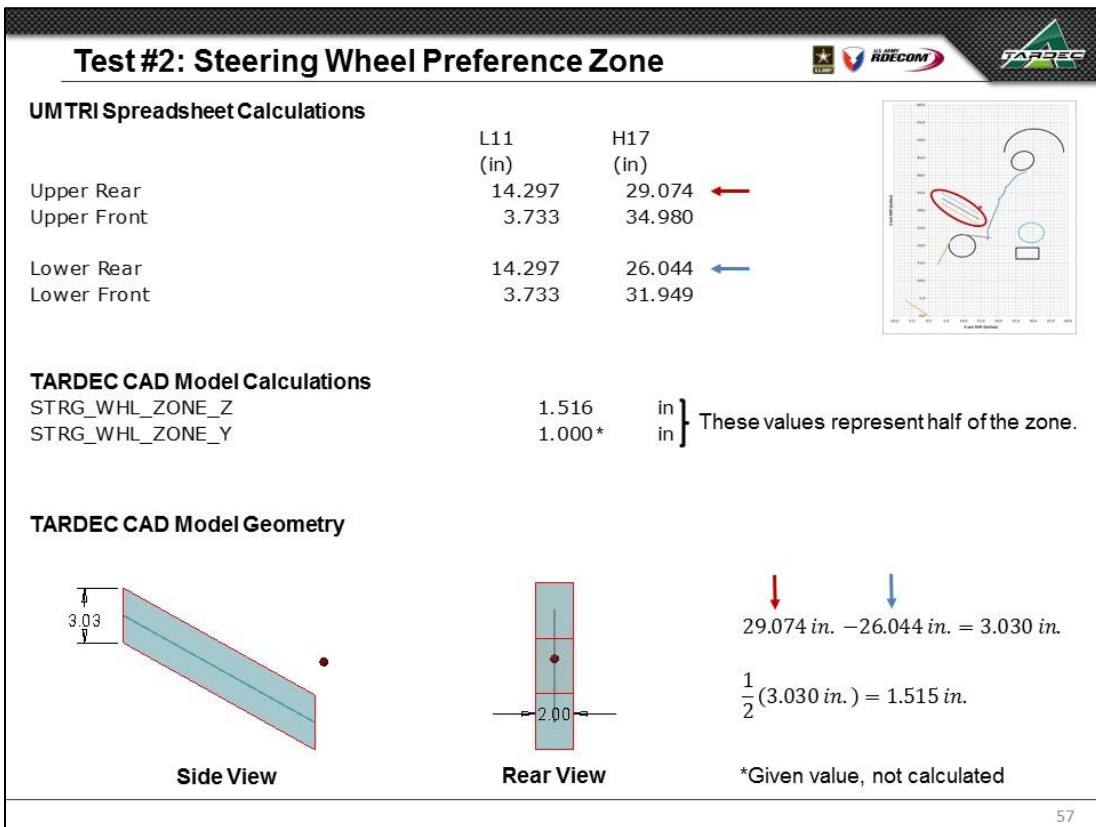
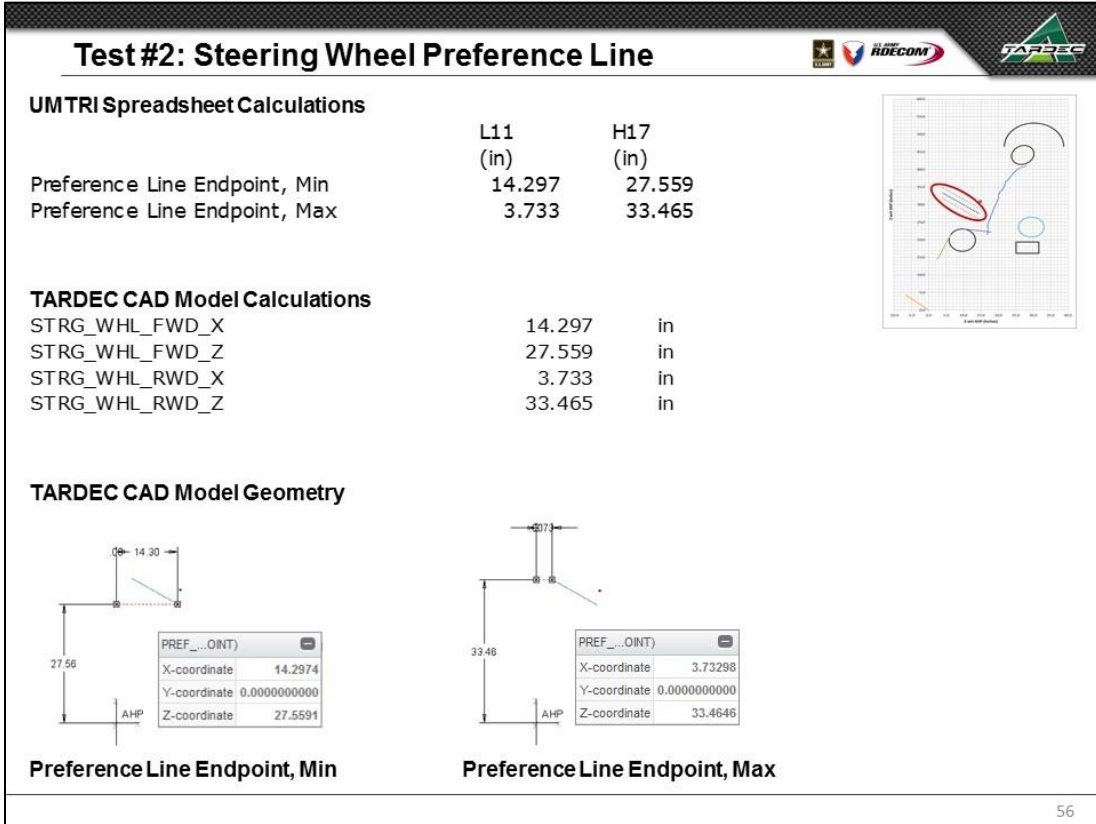

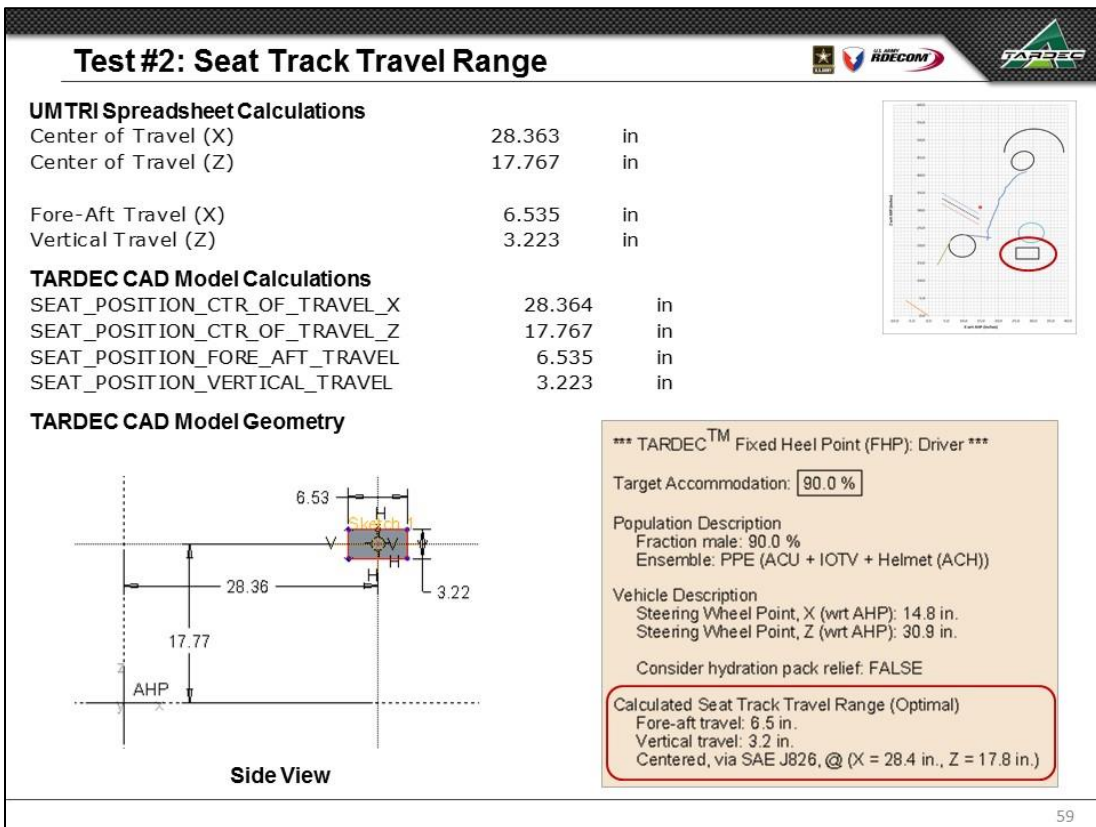
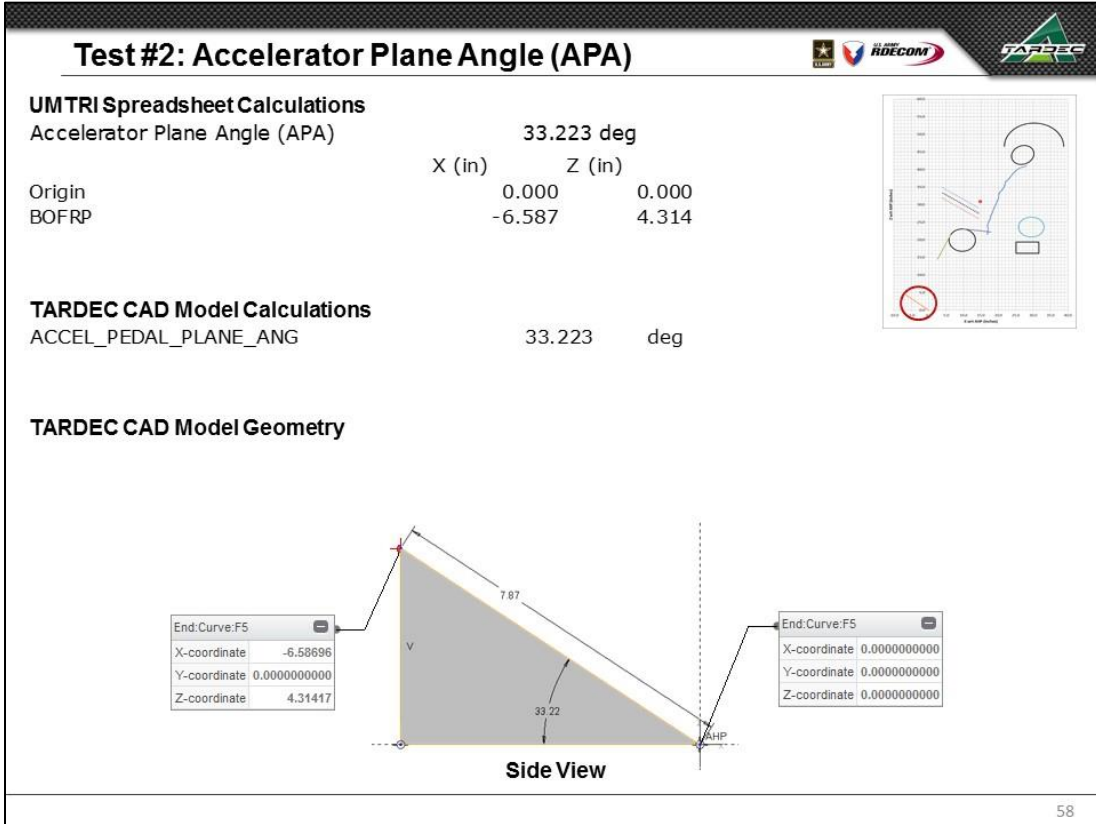

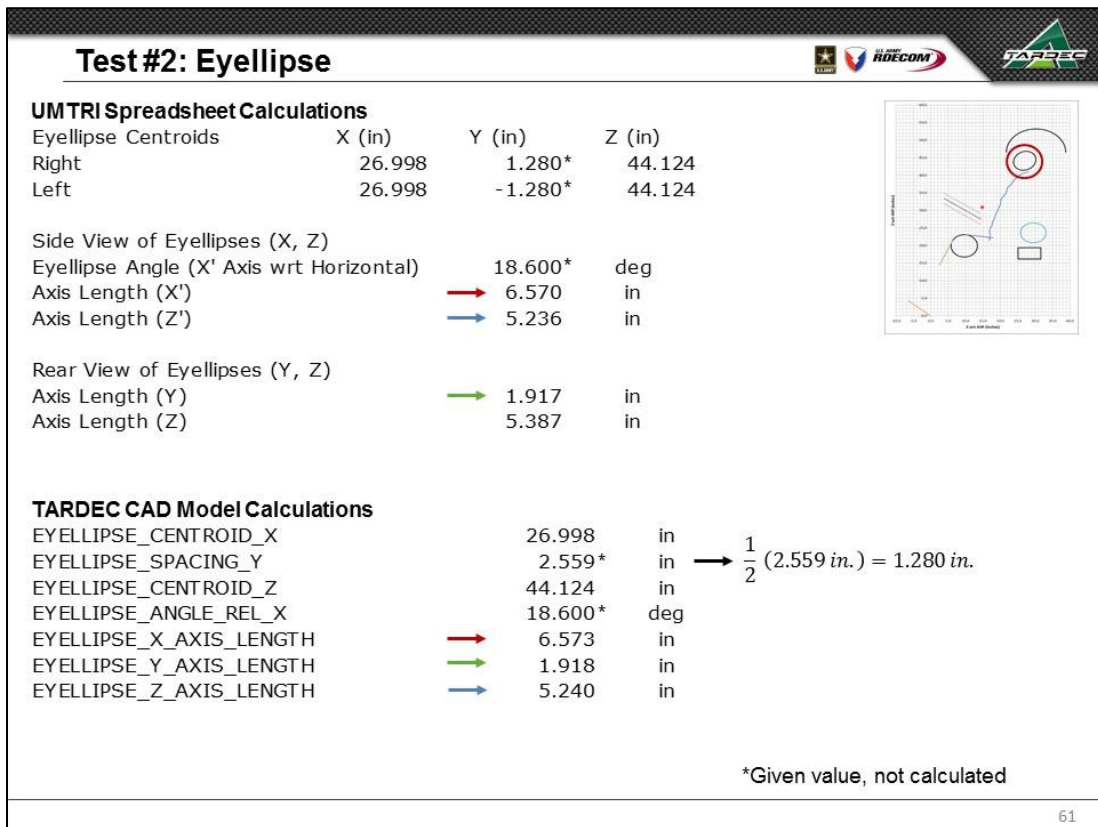
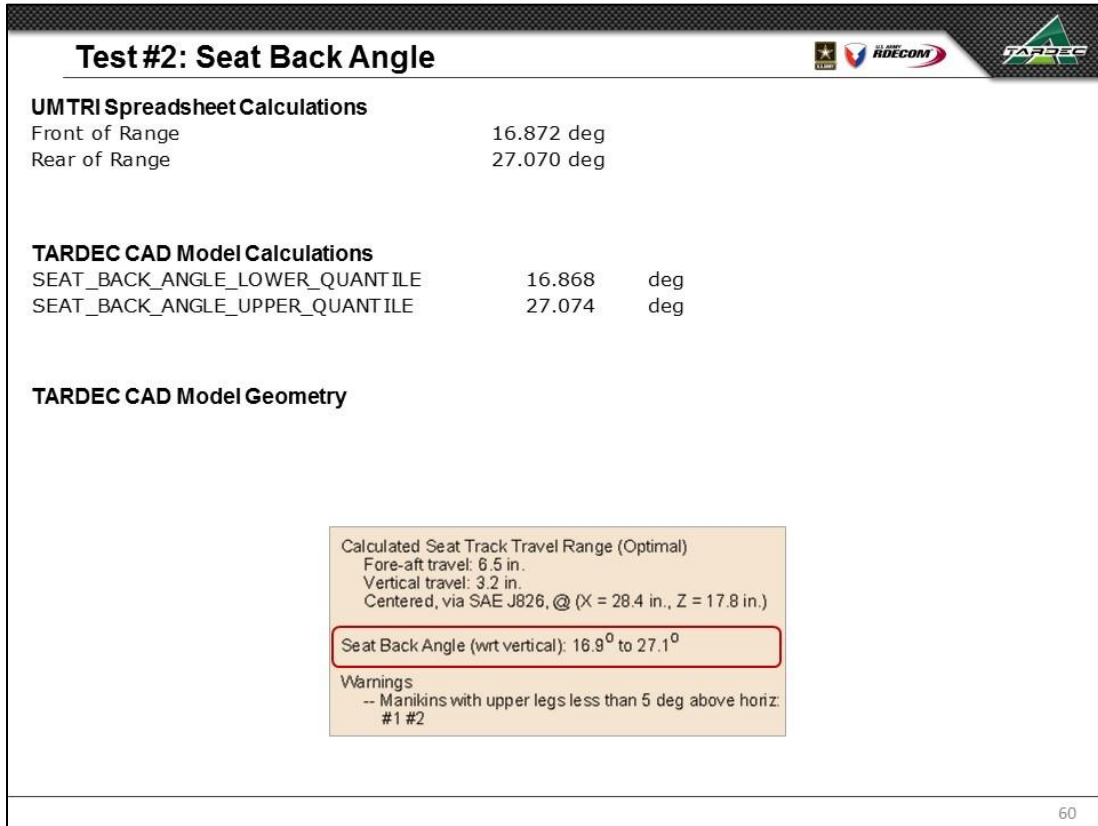

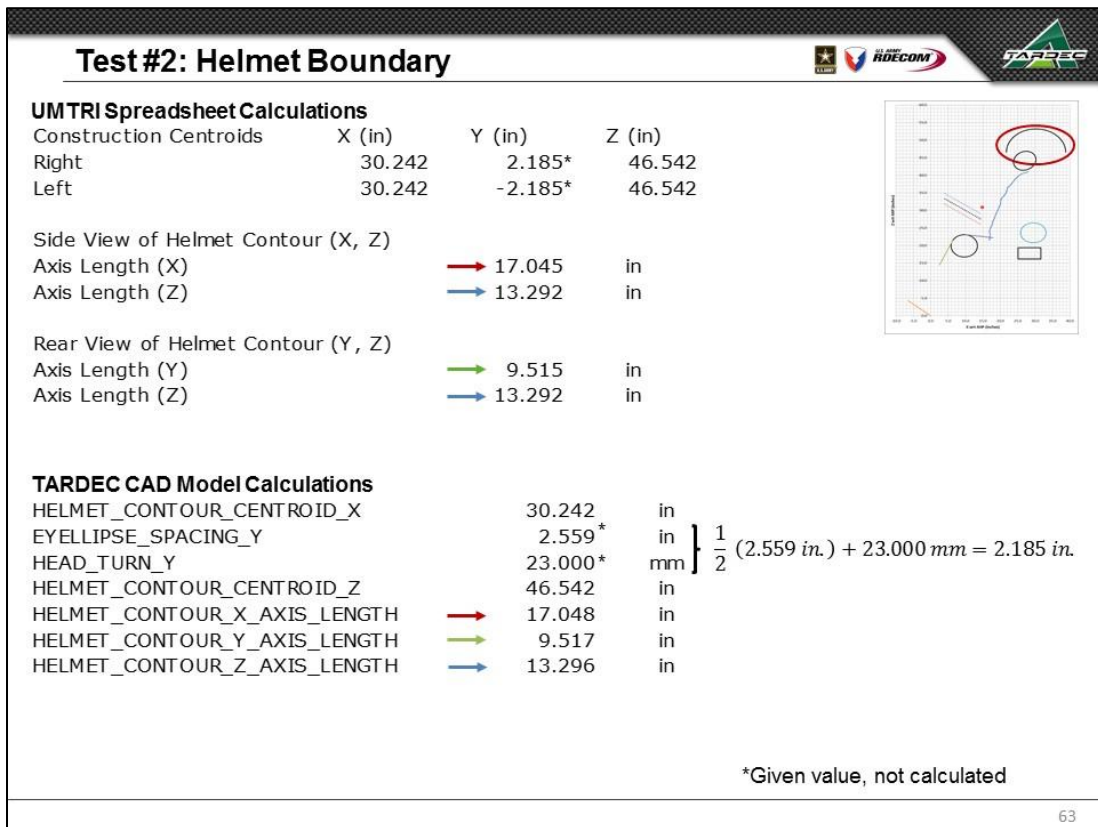
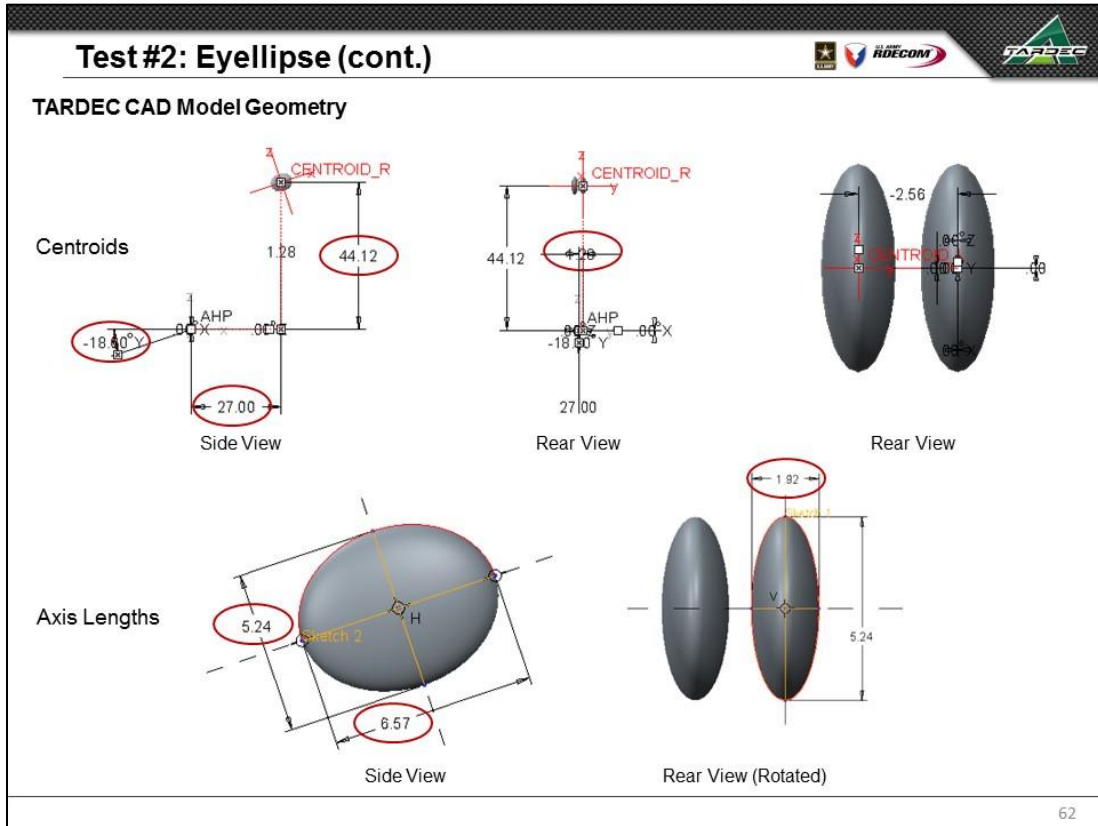

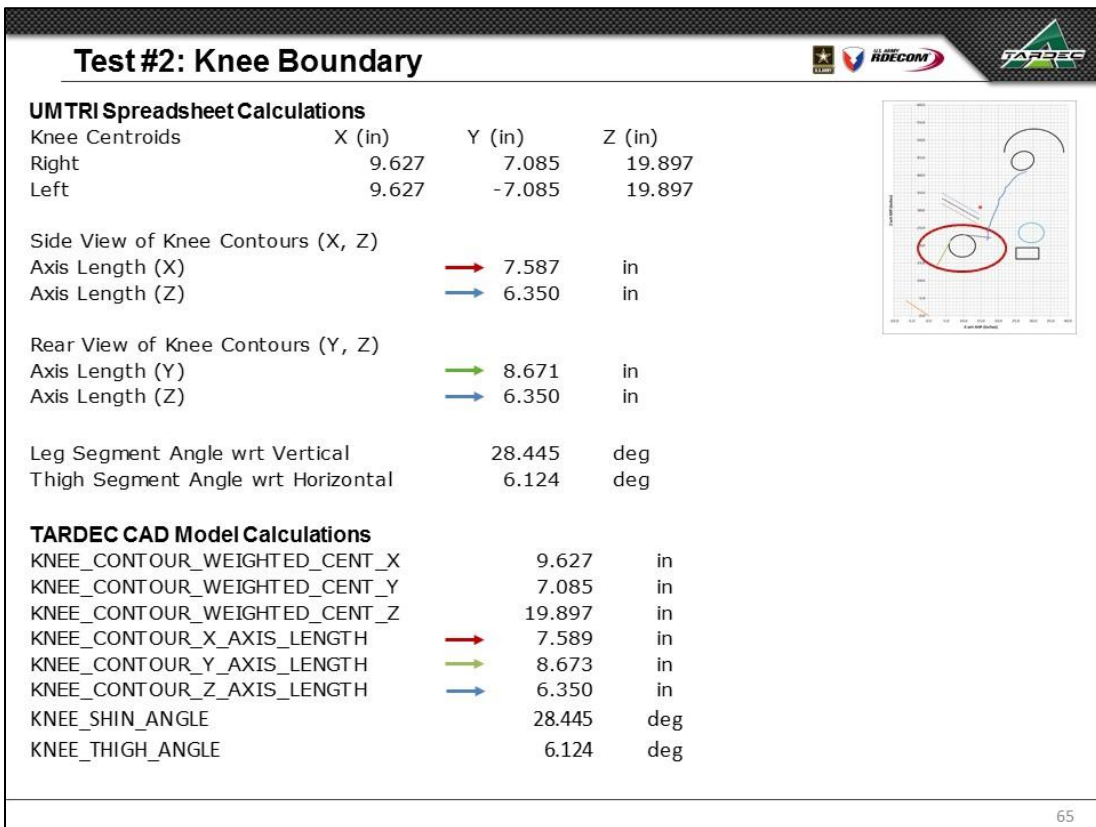
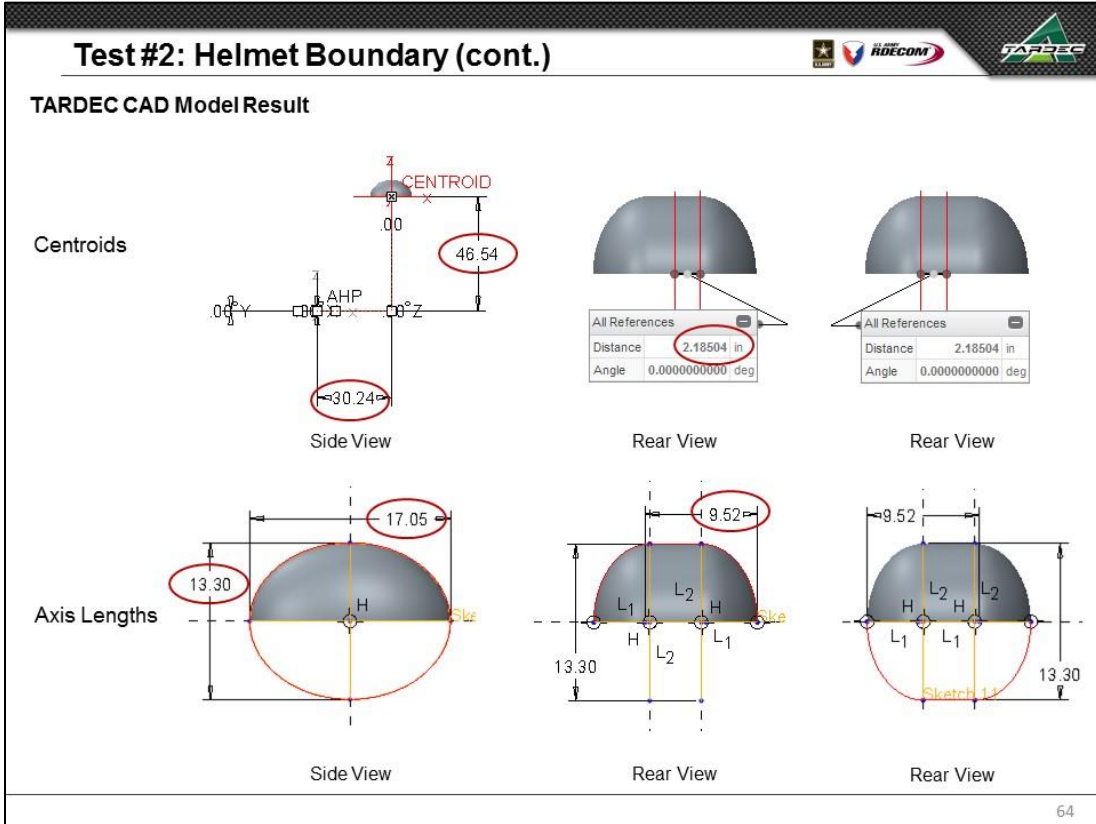

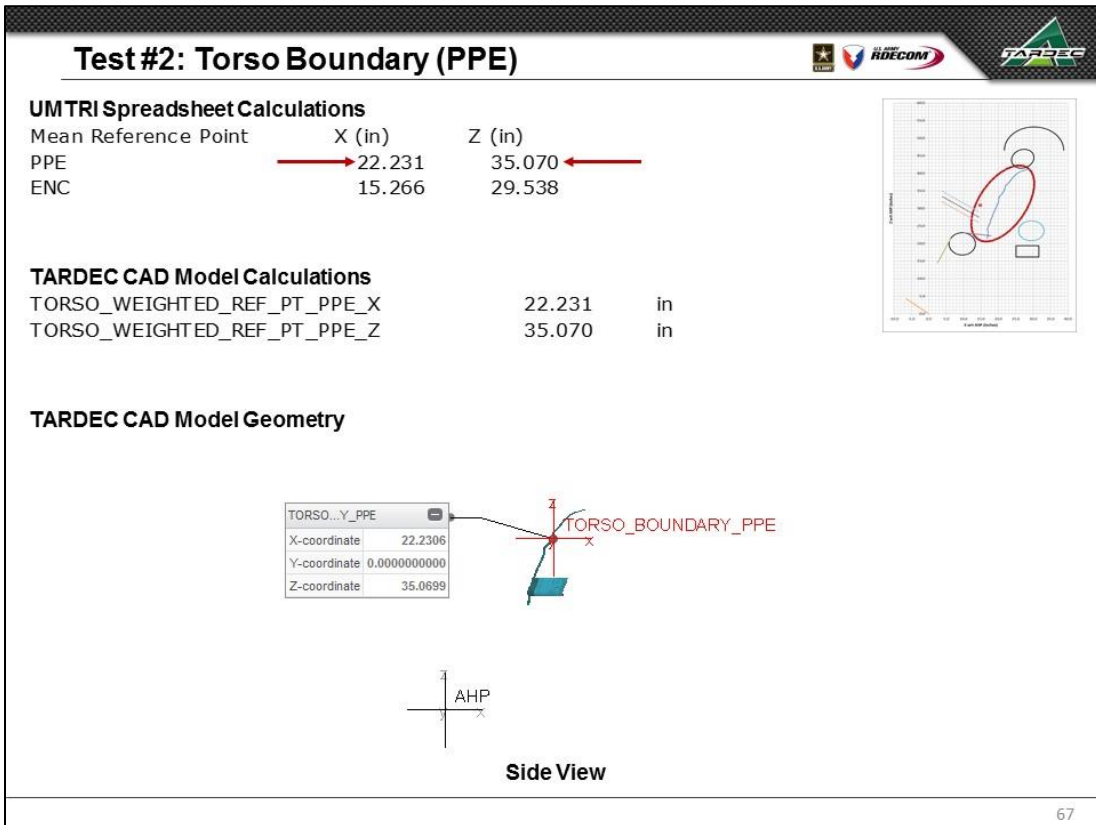
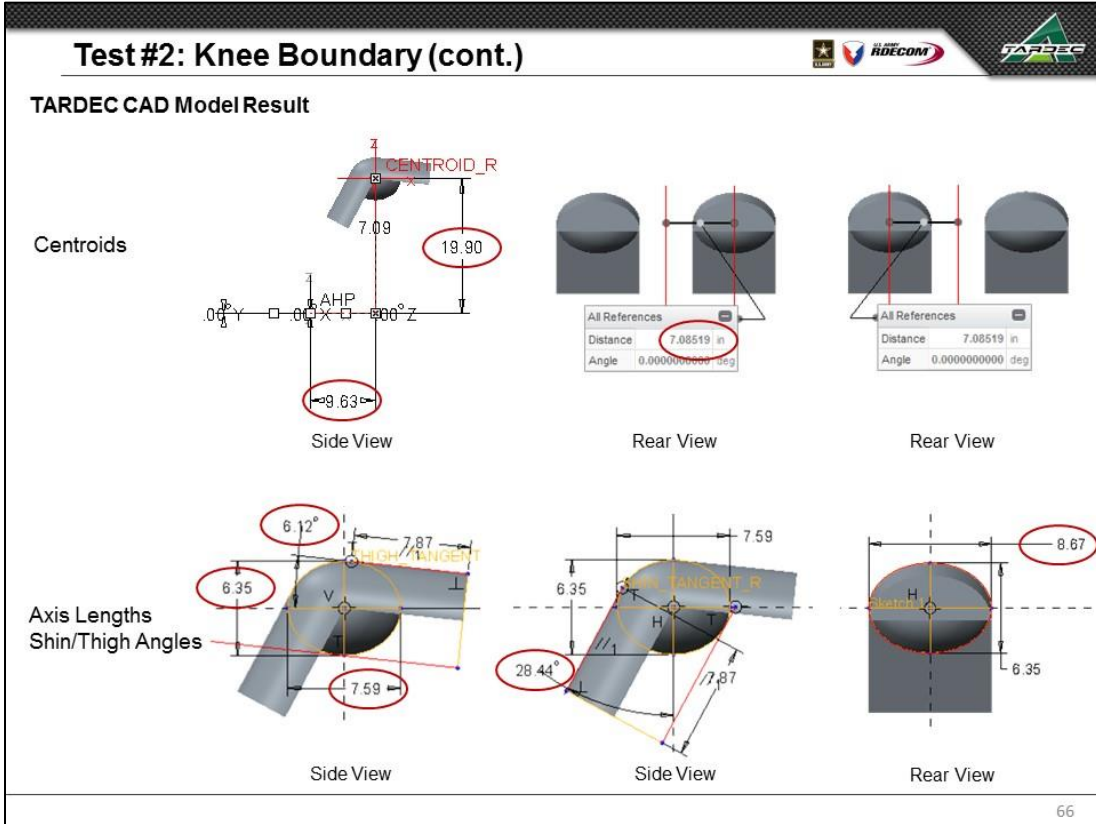

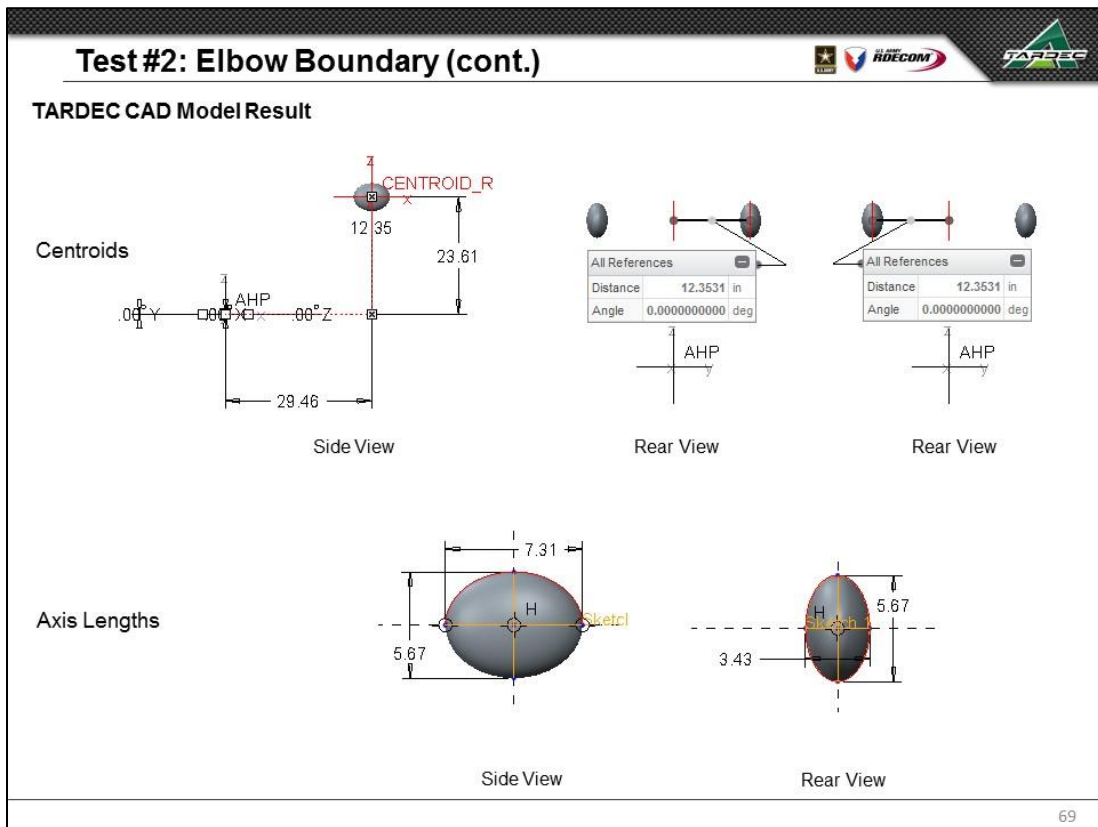
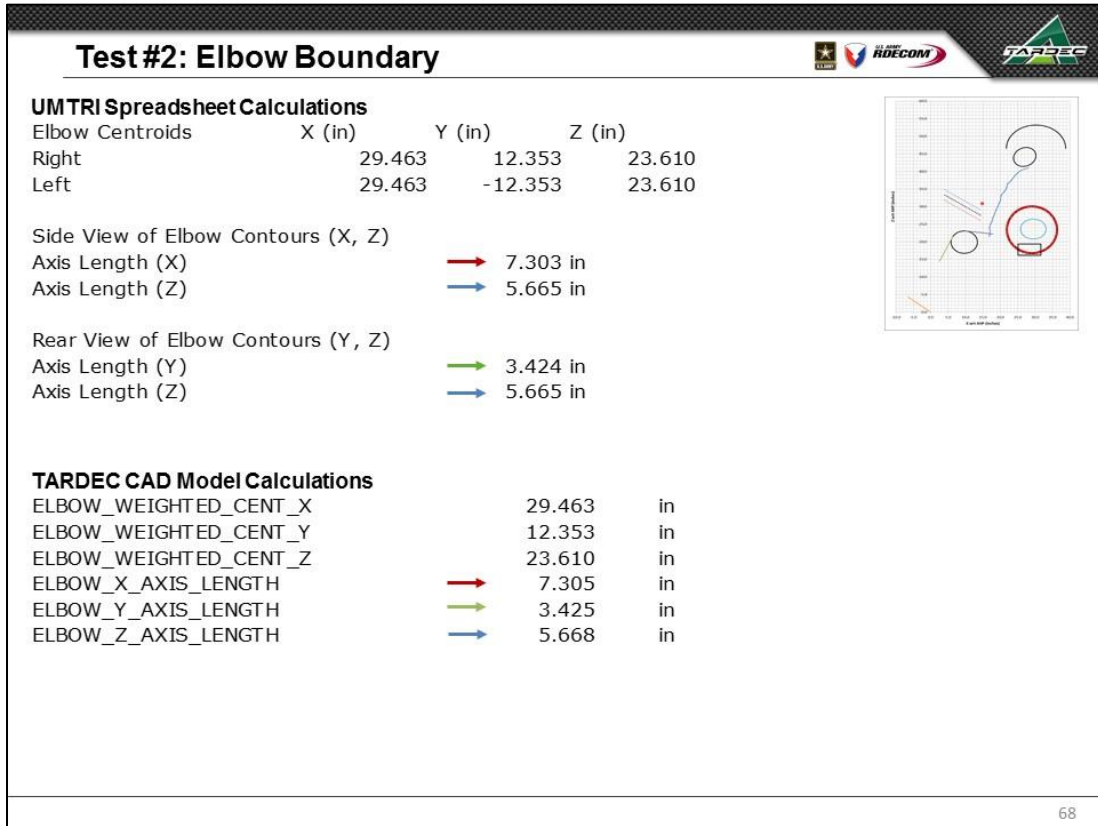



Test #2: Vary Steering Wheel Point (SWP)



Target Accommodation	Fraction Male	Ensemble	Steering Wheel Point (SWP) (measured wrt AHP)		Hydration Pack Relief Availability	HARP Measurement Tool
			X (in.) (L11, fore-aft)	Z (in.) (H17, vertical)		
90%	90%	PPE	14.8	30.9	No	SAE J826

Clearance (2.0 inches), Shown in Yellow



TARDEC CAD Model

70

Test #2: Clearance, Helmet Boundary



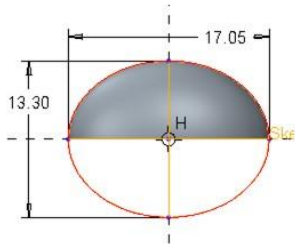

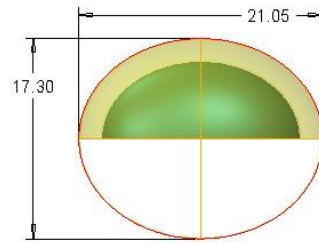

Sample Calculation: $\frac{1}{2} (21.048 \text{ in.} - 17.048 \text{ in.}) = 2.000 \text{ in. clearance}$

Side View

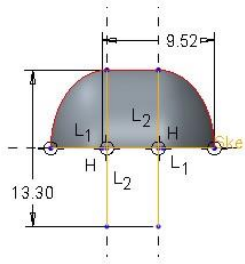

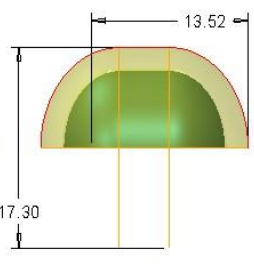

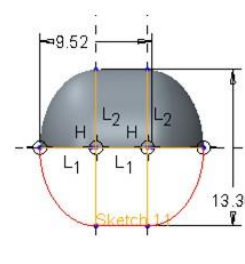

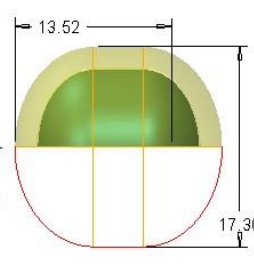

Rear View

71

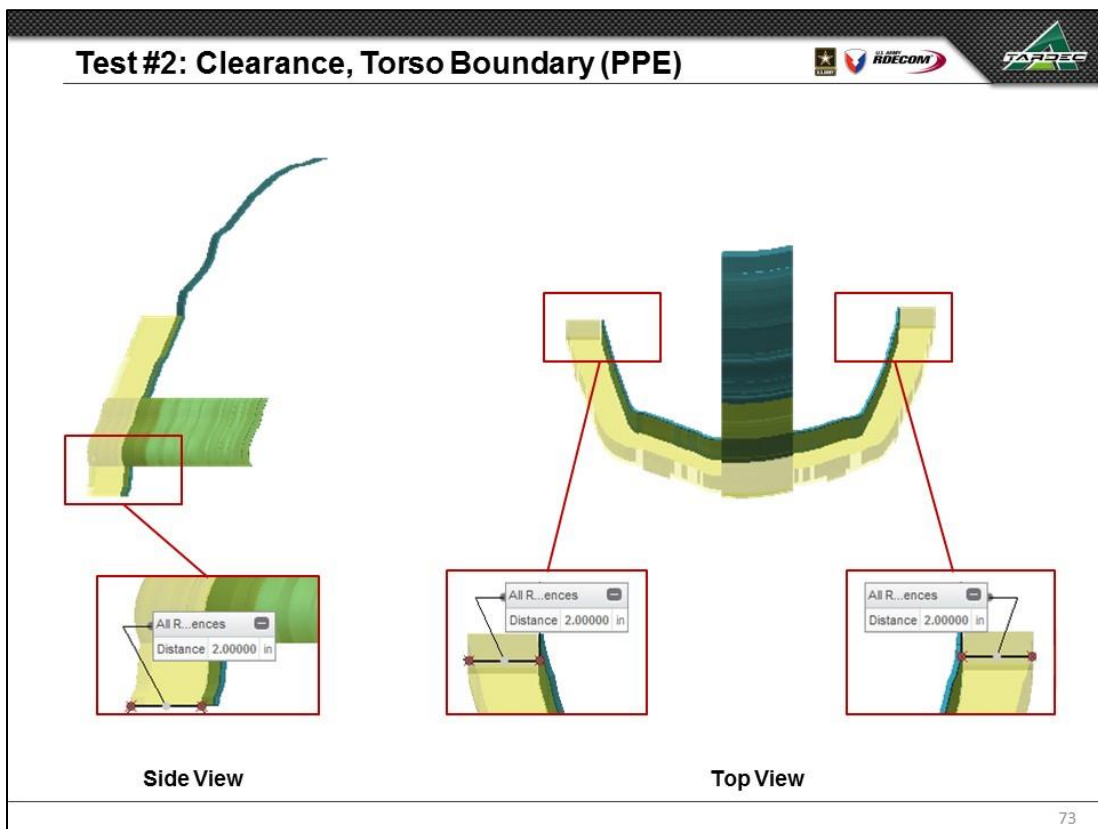
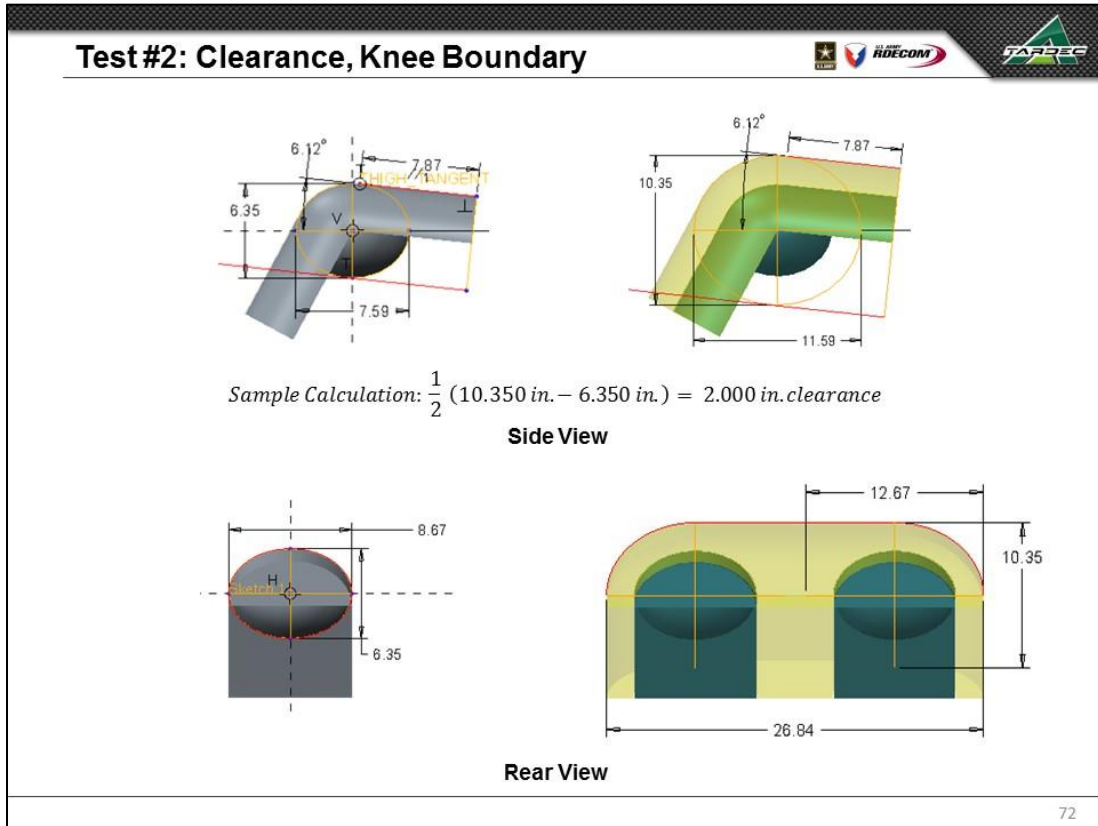

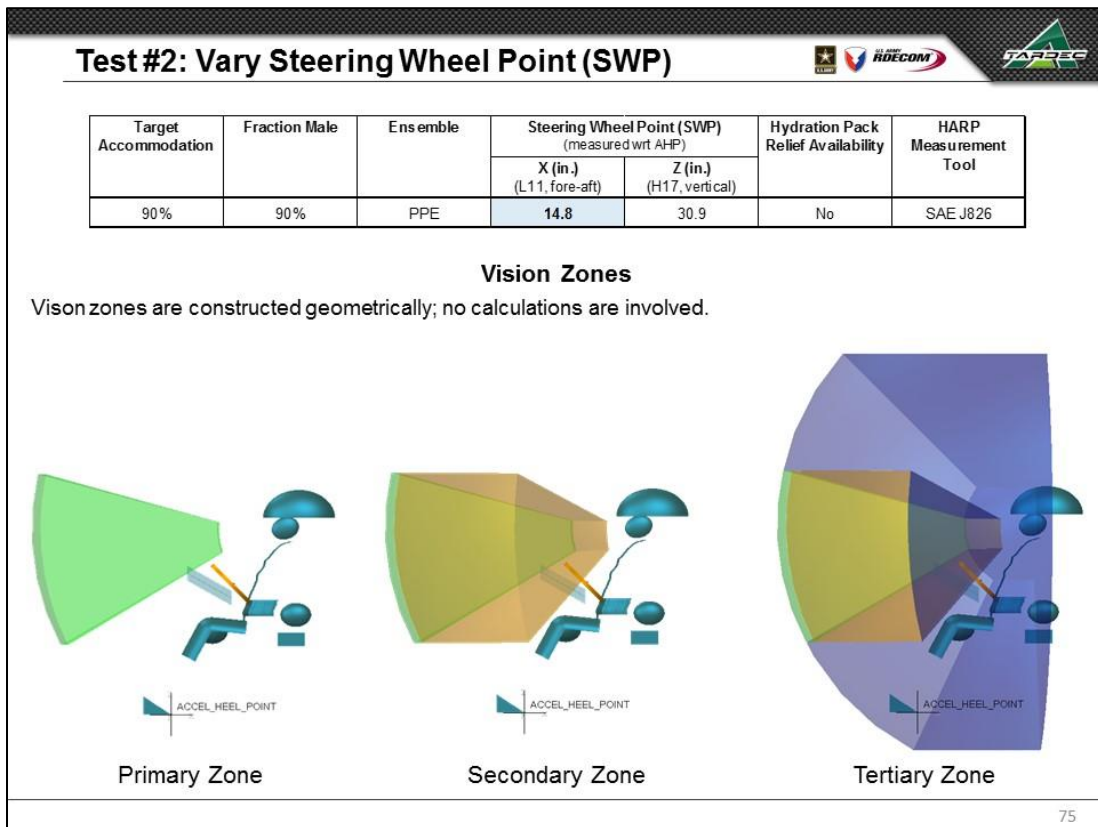
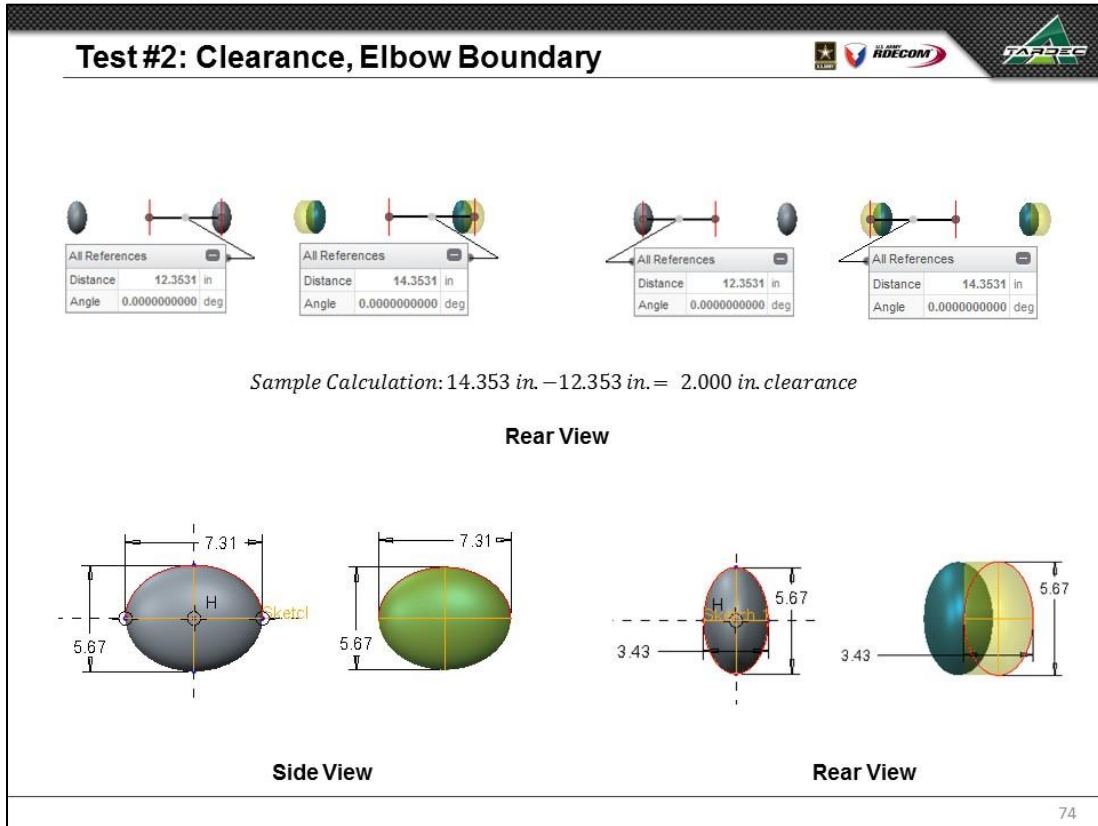

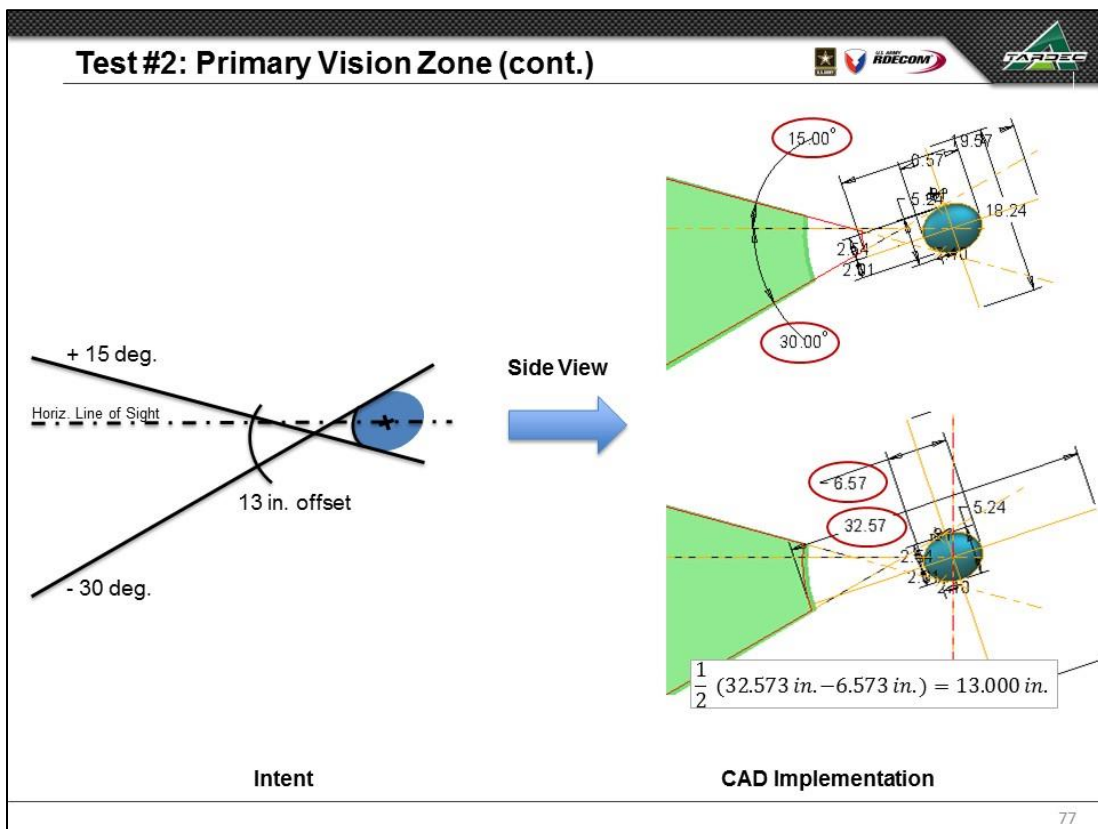
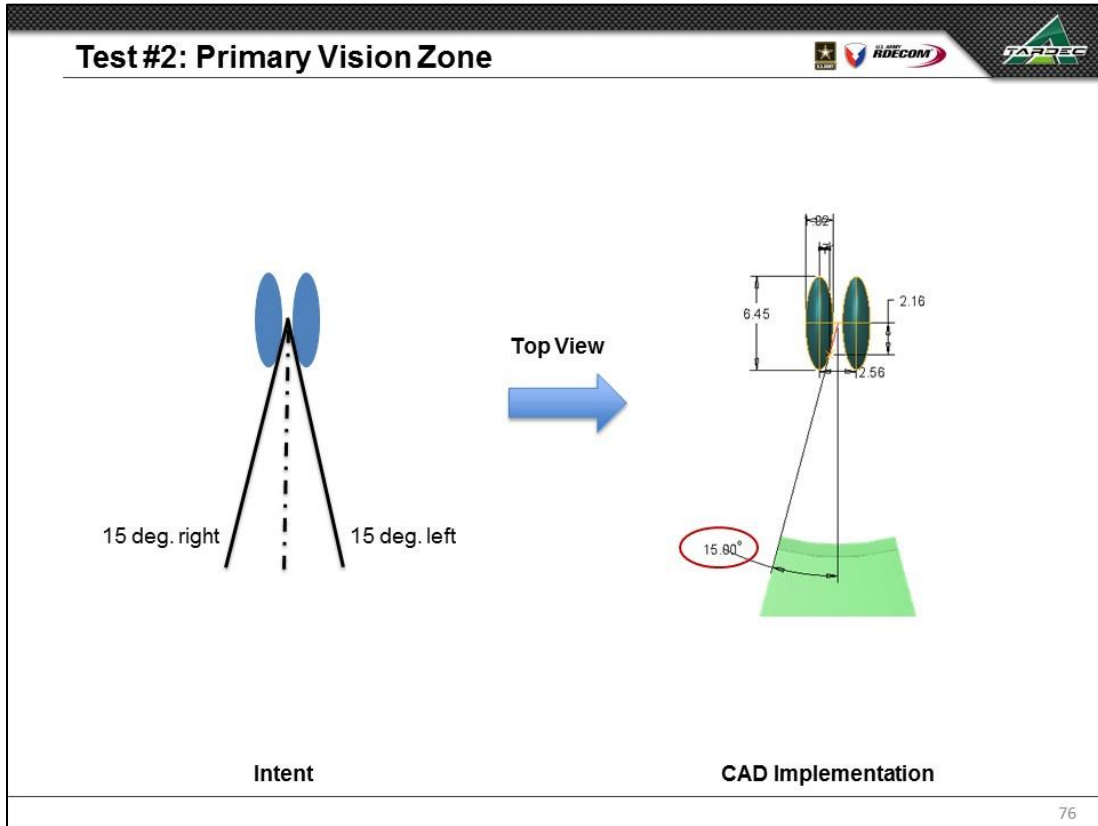

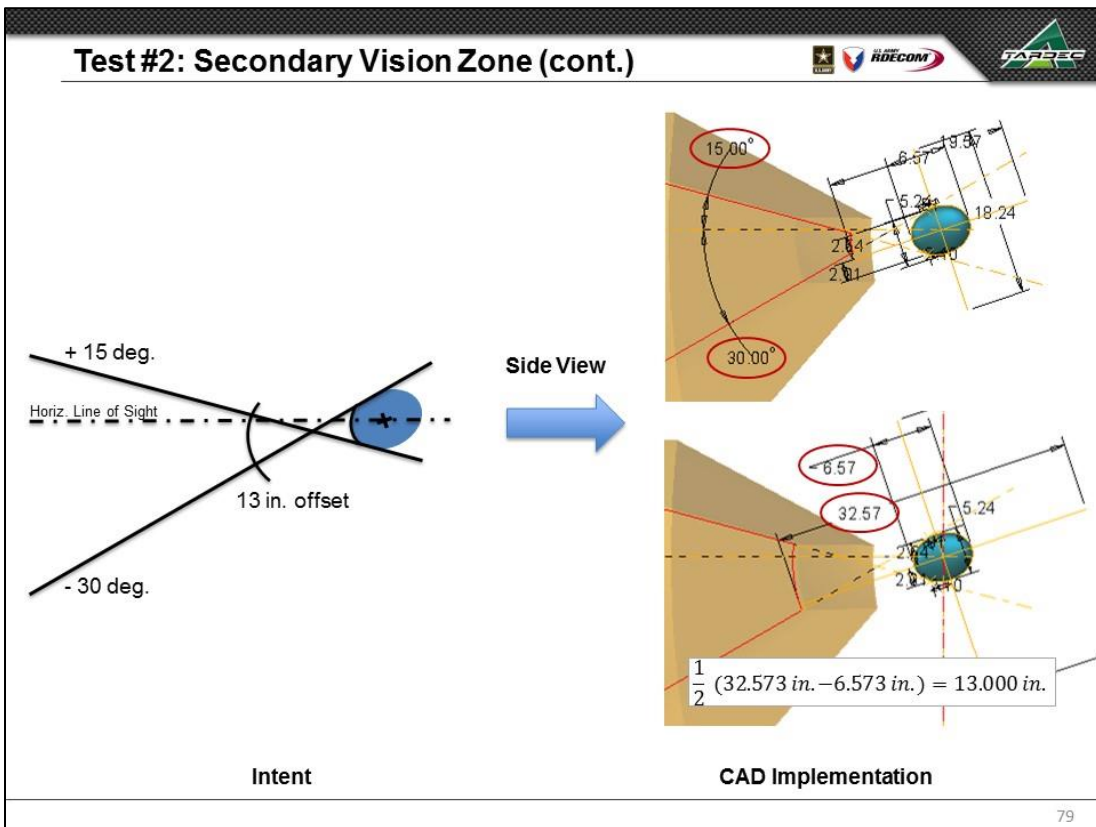
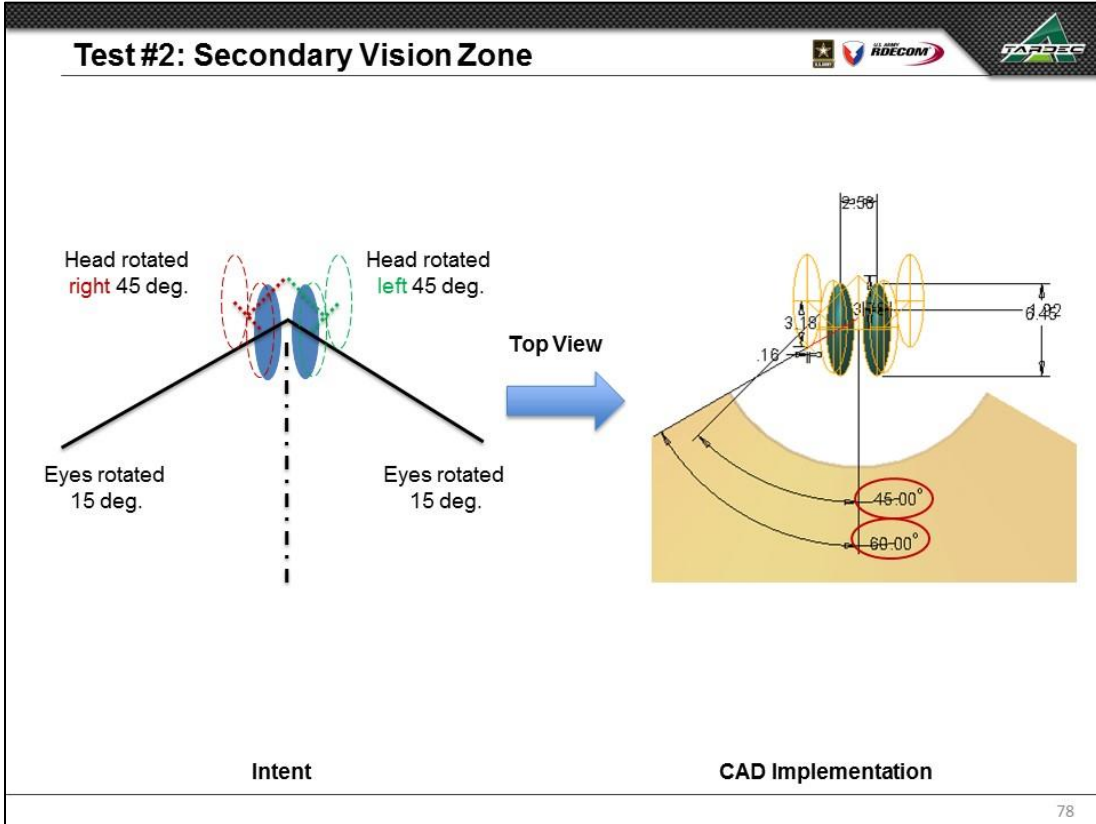

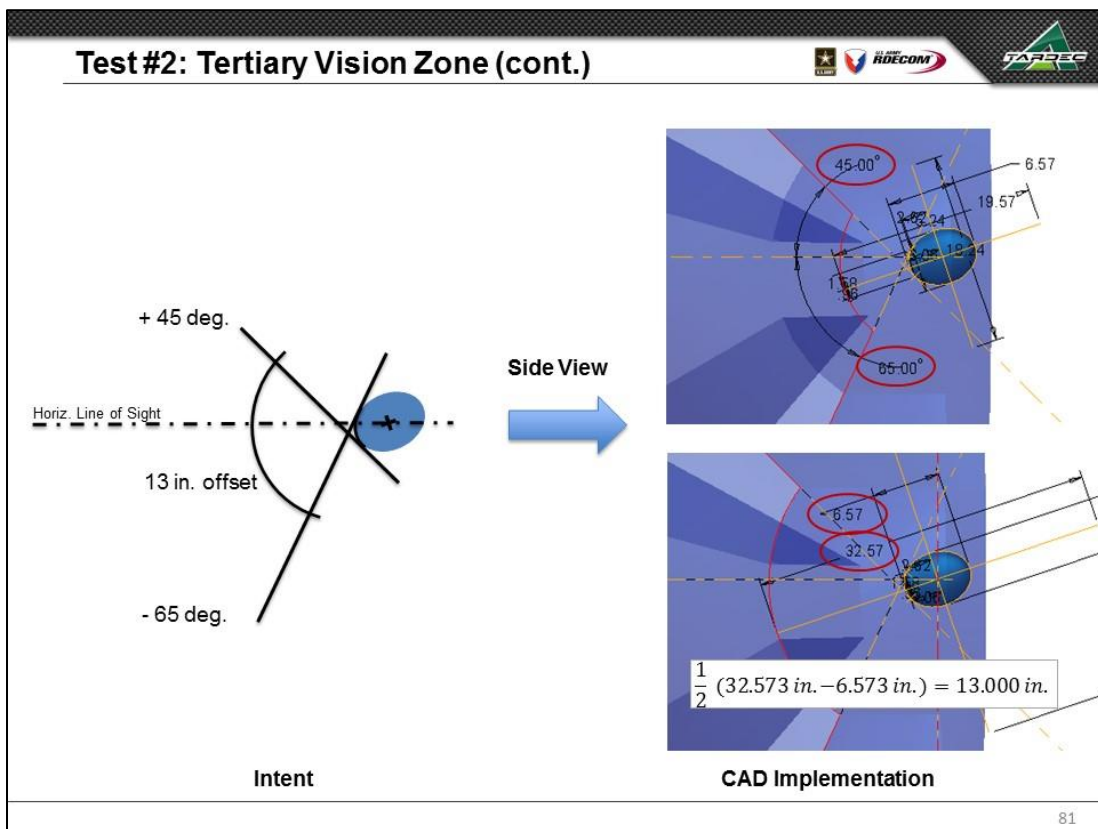
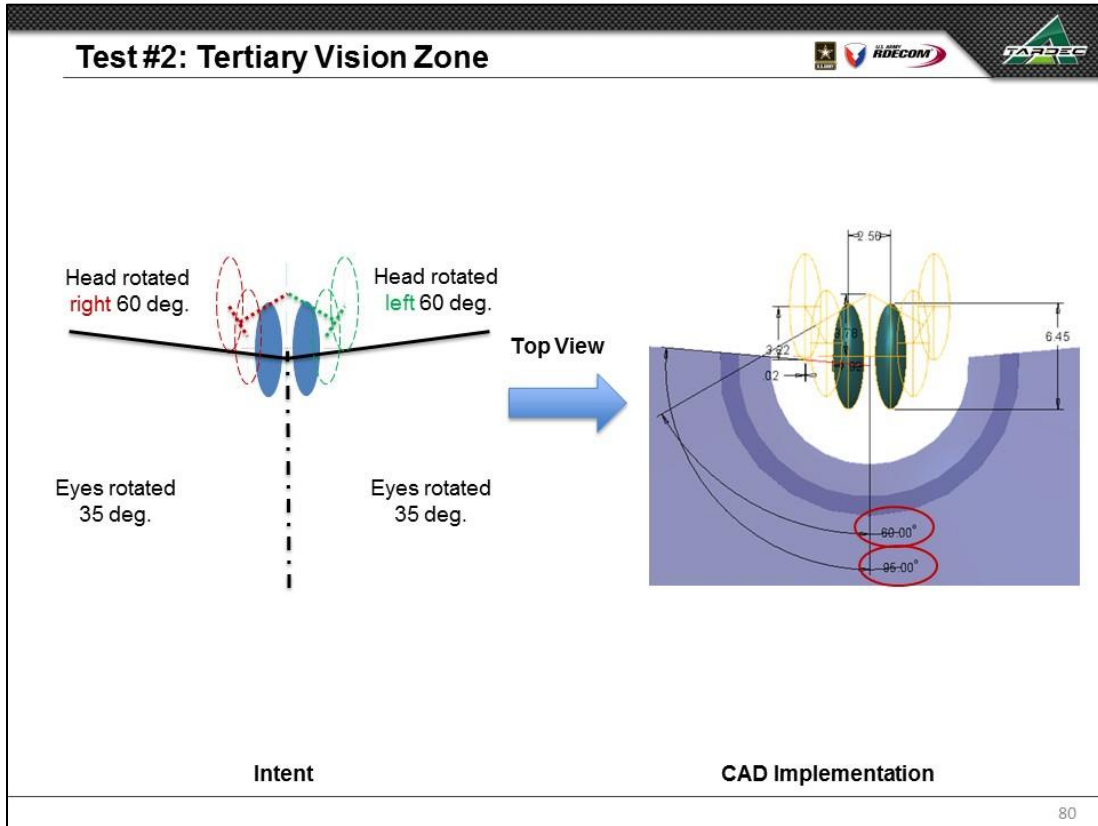



Test #2: Vary Steering Wheel Point (SWP)



Target Accommodation	Fraction Male	Ensemble	Steering Wheel Point (SWP) (measured wrt AHP)		Hydration Pack Relief Availability	HARP Measurement Tool
			X (in.) (L11, fore-aft)	Z (in.) (H17, vertical)		
90%	90%	PPE	14.8	30.9	No	SAE J826

Boundary Manikin Posture and Position



TARDEC CAD Model

82

Test #2: Numerical Results, Manikin Positioning



Small Overall Female			
	UMTRI Value	TARDEC Value	Difference
POSTURE_DHM1_HIP_X	23.709 in	23.709 in	0.000 in
POSTURE_DHM1_HIP_Z	17.617 in	17.617 in	0.000 in
POSTURE_DHM1_EYE_X	25.180 in	25.180 in	0.000 in
POSTURE_DHM1_EYE_Z	40.128 in	40.128 in	0.000 in
Small Overall Male			
	UMTRI Value	TARDEC Value	Difference
POSTURE_DHM2_HIP_X	25.831 in	25.831 in	0.000 in
POSTURE_DHM2_HIP_Z	17.727 in	17.727 in	0.000 in
POSTURE_DHM2_EYE_X	26.431 in	26.431 in	0.000 in
POSTURE_DHM2_EYE_Z	41.895 in	41.895 in	0.000 in
Average Size Male			
	UMTRI Value	TARDEC Value	Difference
POSTURE_DHM3_HIP_X	28.027 in	28.027 in	0.000 in
POSTURE_DHM3_HIP_Z	17.726 in	17.726 in	0.000 in
POSTURE_DHM3_EYE_X	27.839 in	27.839 in	0.000 in
POSTURE_DHM3_EYE_Z	44.119 in	44.119 in	0.000 in
Widest Shoulders Male			
	UMTRI Value	TARDEC Value	Difference
POSTURE_DHM4_HIP_X	29.035 in	29.035 in	0.000 in
POSTURE_DHM4_HIP_Z	17.715 in	17.715 in	0.000 in
POSTURE_DHM4_EYE_X	28.495 in	28.495 in	0.000 in
POSTURE_DHM4_EYE_Z	45.397 in	45.397 in	0.000 in
Longest Torso Male			
	UMTRI Value	TARDEC Value	Difference
POSTURE_DHM5_HIP_X	28.278 in	28.278 in	0.000 in
POSTURE_DHM5_HIP_Z	17.709 in	17.709 in	0.000 in
POSTURE_DHM5_EYE_X	28.005 in	28.005 in	0.000 in
POSTURE_DHM5_EYE_Z	46.398 in	46.398 in	0.000 in
Longest Legs Male			
	UMTRI Value	TARDEC Value	Difference
POSTURE_DHM6_HIP_X	30.551 in	30.551 in	0.000 in
POSTURE_DHM6_HIP_Z	17.780 in	17.780 in	0.000 in
POSTURE_DHM6_EYE_X	29.416 in	29.416 in	0.000 in
POSTURE_DHM6_EYE_Z	44.618 in	44.618 in	0.000 in
Large Overall Male			
	UMTRI Value	TARDEC Value	Difference
POSTURE_DHM7_HIP_X	30.376 in	30.376 in	0.000 in
POSTURE_DHM7_HIP_Z	17.877 in	17.877 in	0.000 in
POSTURE_DHM7_EYE_X	29.192 in	29.192 in	0.000 in
POSTURE_DHM7_EYE_Z	46.357 in	46.357 in	0.000 in

TARDEC CAD values to agree with UMTRI spreadsheet values within
 ±0.100 inches
 ±0.100 degrees

Largest Observed Differences:
 0.000 inches

Values in agreement

83

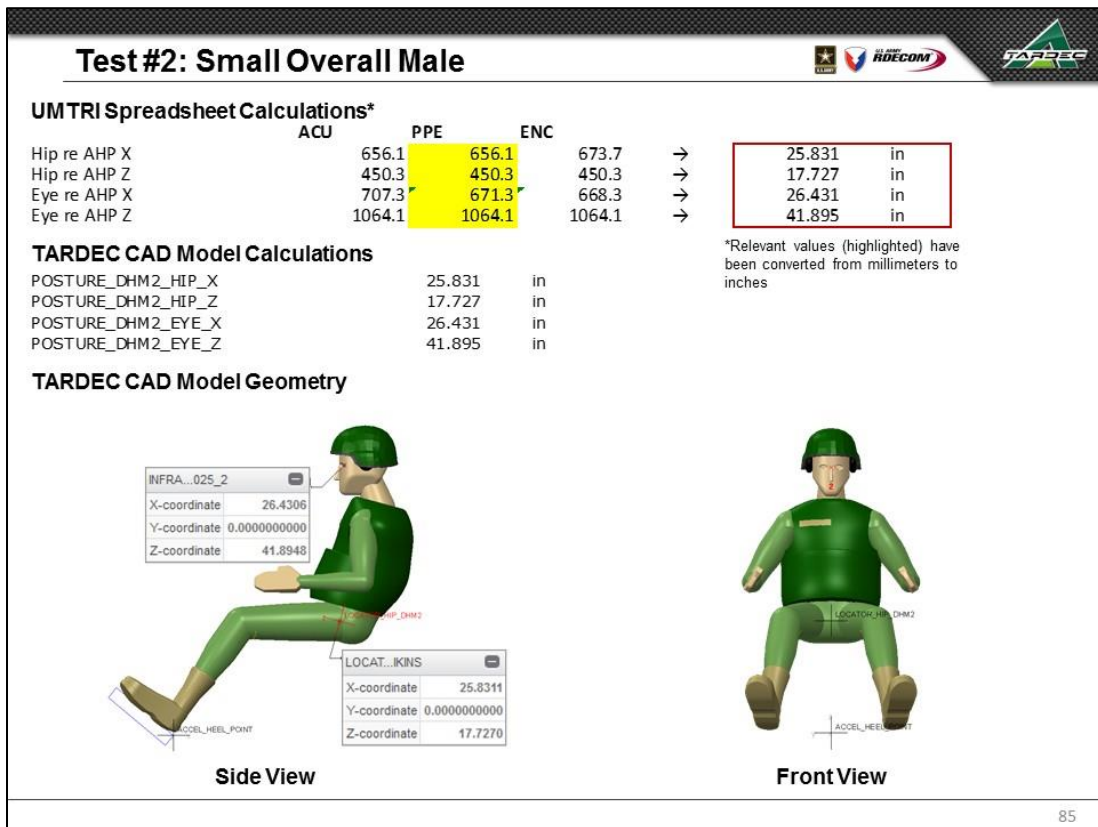
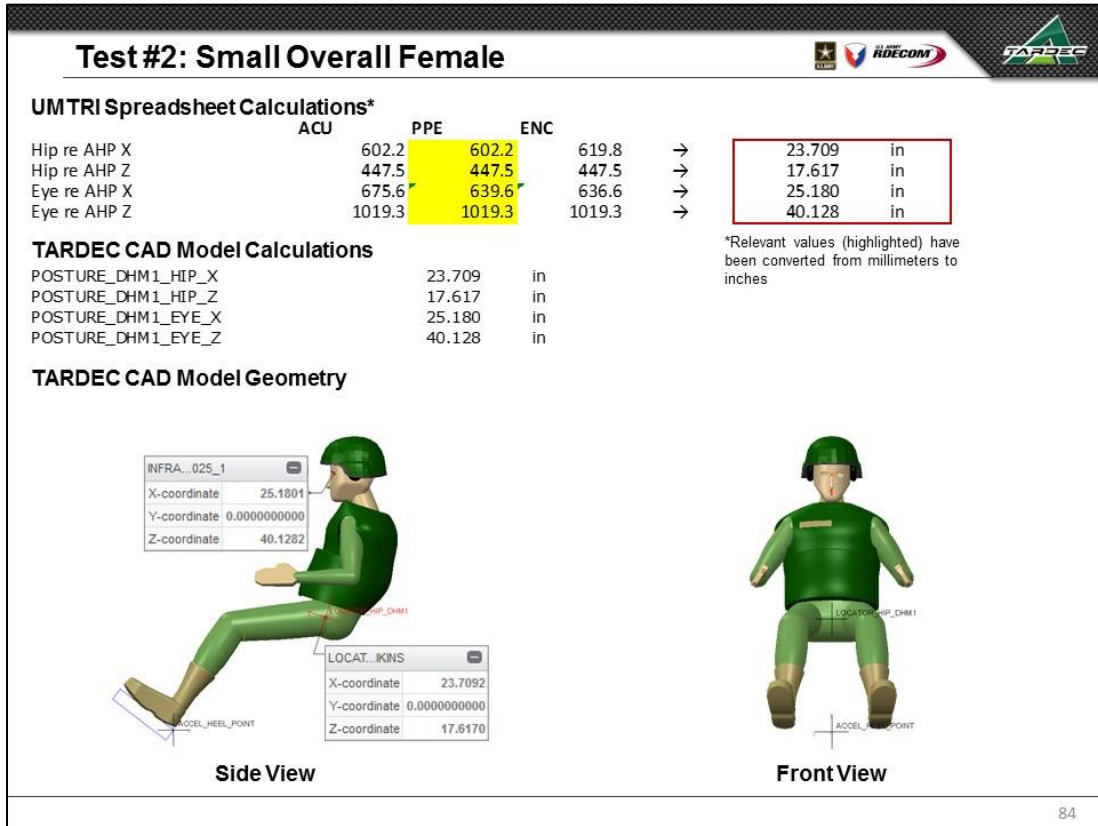

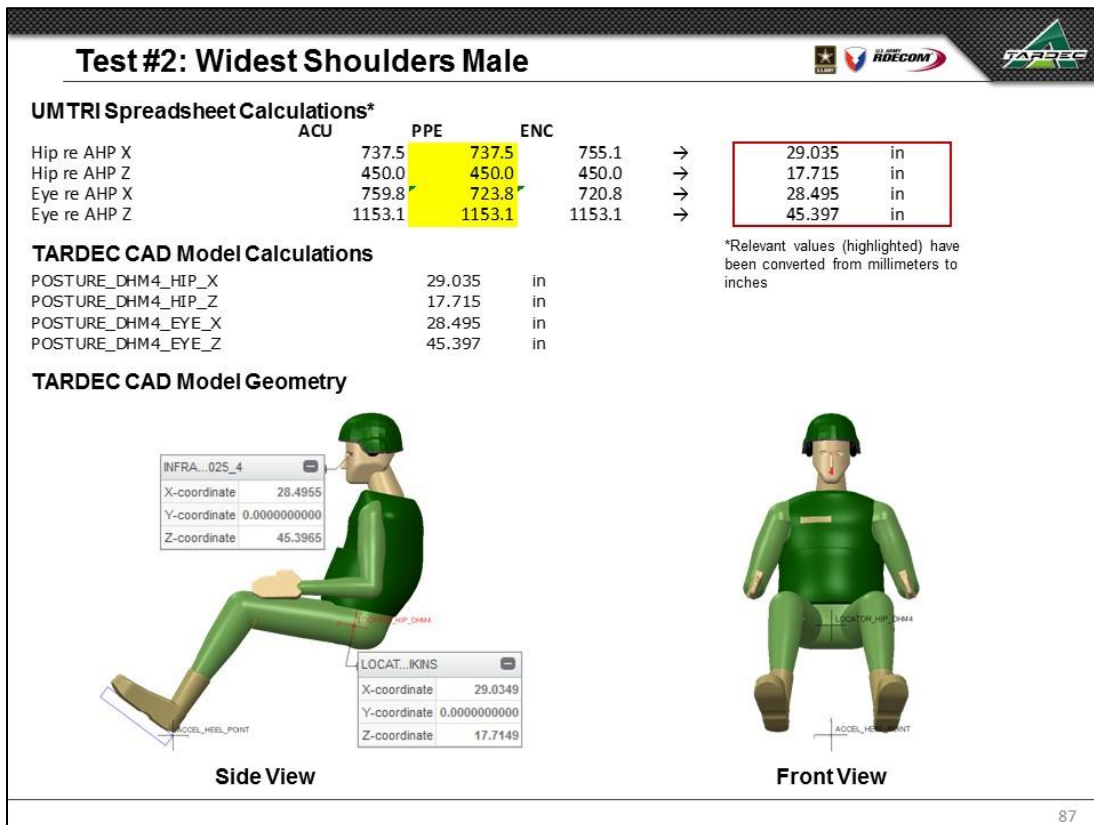
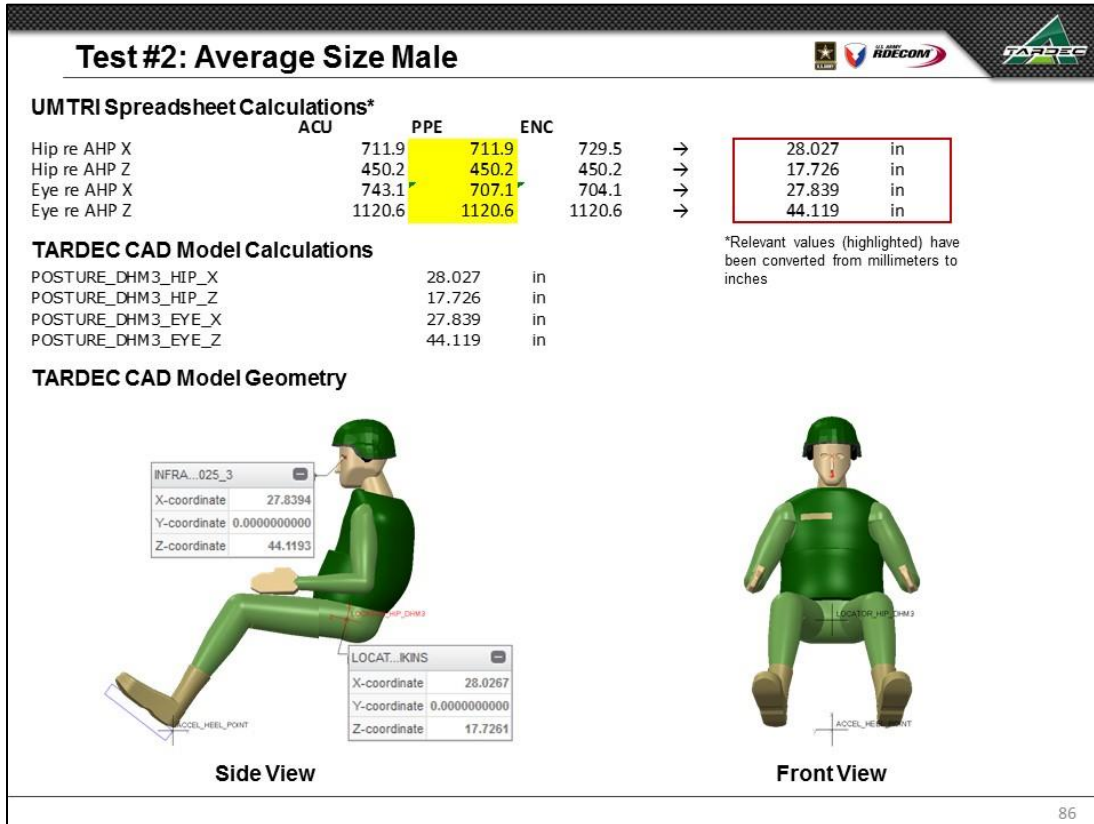

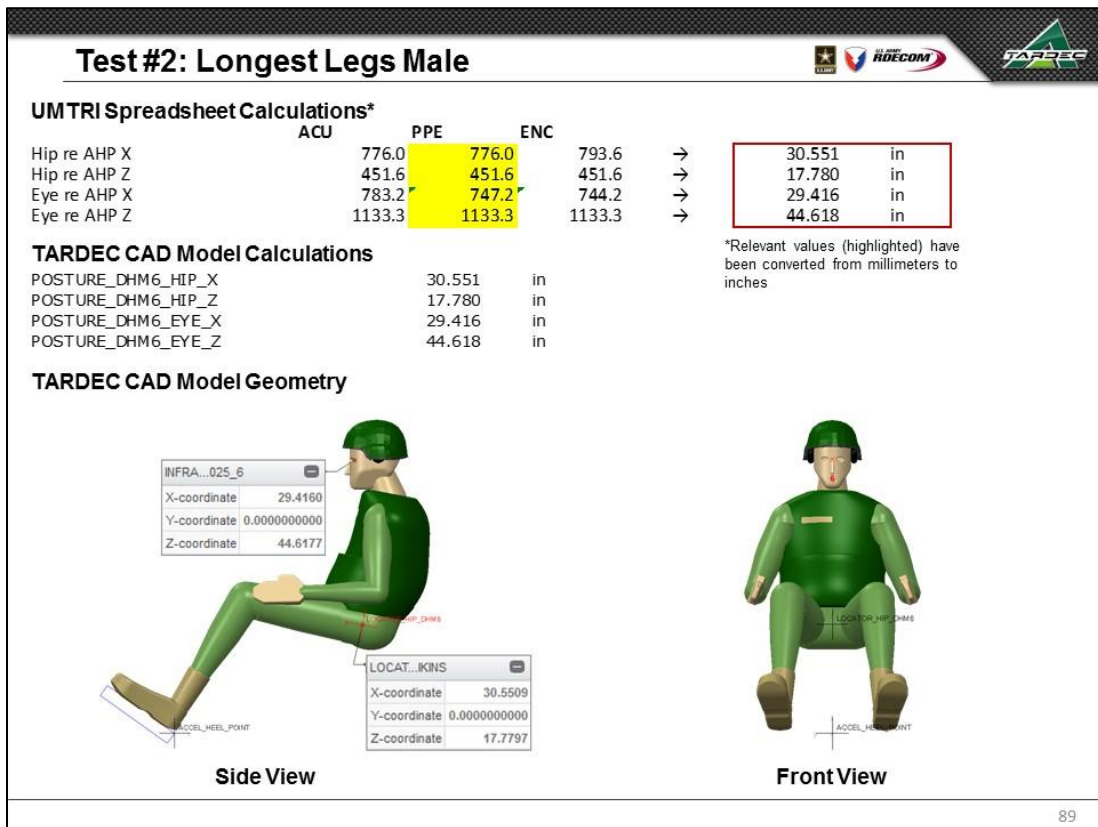
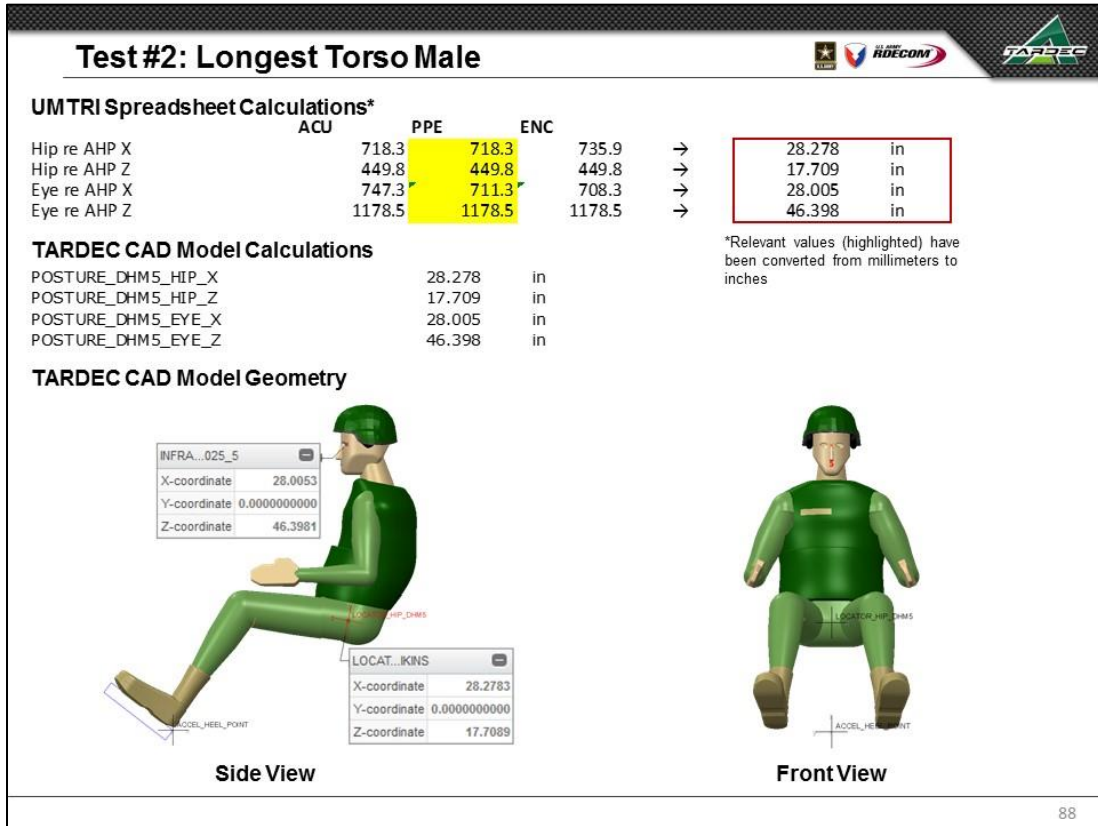

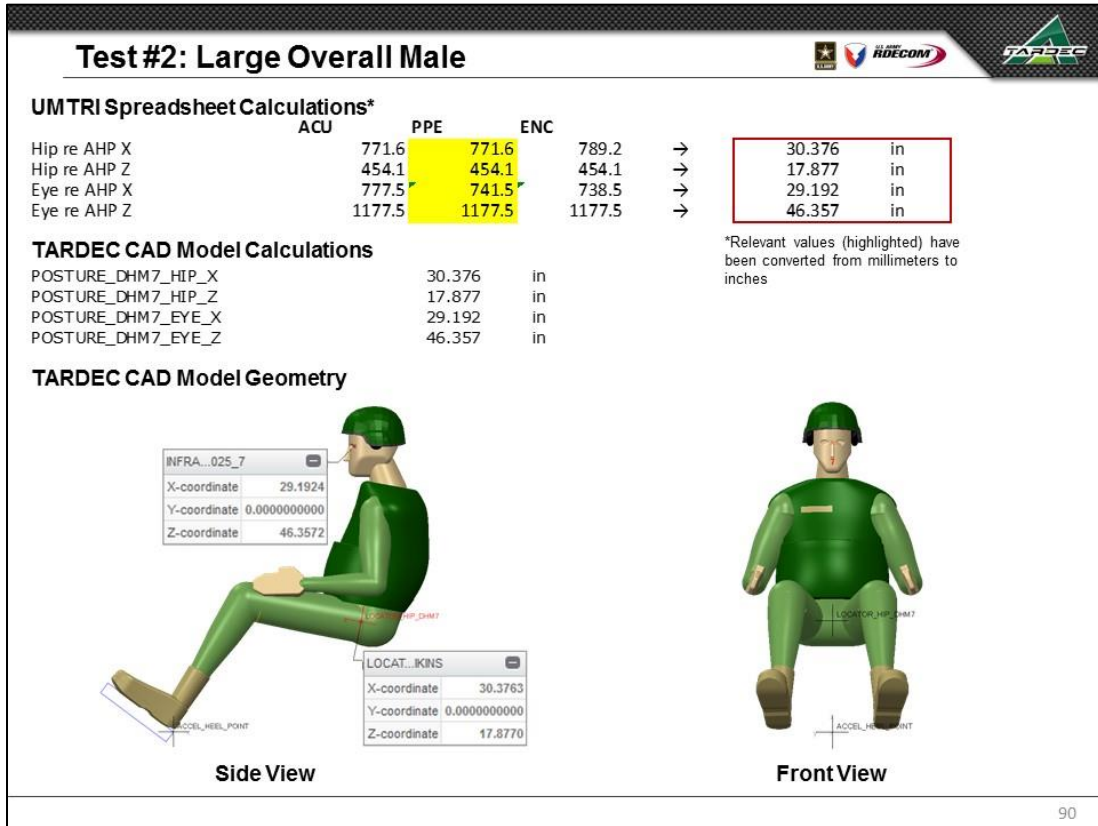

10.7.3 TEST #3 – VARY SWP IN FORE-AFT (X) AND VERTICAL (Z) POSITION AND USE ALTERNATE HARP TOOL

Test #3: Vary SWP and Use Alternate HARP Tool



Target Accommodation	Fraction Male	Ensemble	Steering Wheel Point (SWP) (measured wrt AHP)		Hydration Pack Relief Availability	HARP Measurement Tool
			X (in.) (L11, fore-aft)	Z (in.) (H17, vertical)		
90%	90%	PPE	13.3	29.0	No	ISO 5353

Basic Accommodation

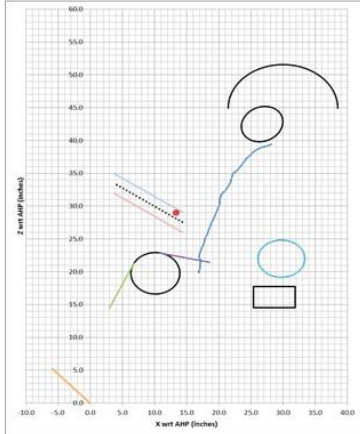

UMTRI Spreadsheet



TARDEC CAD Model

91

Test #3: Numerical Results, Accommodation

Surrogate Steering Wheel			
	UMTRI Value	TARDEC Value	Difference
STEERING_WHEEL_X	13.300 in	13.300 in	0.000 in
STEERING_WHEEL_Z	29.000 in	29.000 in	0.000 in
Steering Wheel Preference Line			
	UMTRI Value	TARDEC Value	Difference
STRG_WHL_FWD_X	14.297 in	14.297 in	0.000 in
STRG_WHL_FWD_Z	27.559 in	27.559 in	0.000 in
STRG_WHL_RWD_X	3.733 in	3.733 in	0.000 in
STRG_WHL_RWD_Z	33.465 in	33.465 in	0.000 in
Steering Wheel Preference Zone			
	UMTRI Value	TARDEC Value	Difference
STRG_WHL_ZONE_Z	1.518 in	1.518 in	0.001 in
STRG_WHL_ZONE_Y	N/A	1.000 in	N/A
Accelerator Plane Angle (APA)			
	UMTRI Value	TARDEC Value	Difference
ACCEL_PEDAL_PLANE_ANG	41.438 deg	41.438 deg	0.000 deg
Origin (X)	0.000 in	0.000 in	0.000 in
Origin (Z)	0.000 in	0.000 in	0.000 in
BOFRP (X)	-5.903 in	-5.903 in	0.000 in
BOFRP (Z)	5.211 in	5.211 in	0.000 in
Seat Track Travel Range			
	UMTRI Value	TARDEC Value	Difference
SEAT_POSITION_CTR_OF_TRAVEL_X	28.617 in	28.619 in	0.001 in
SEAT_POSITION_CTR_OF_TRAVEL_Z	16.146 in	16.146 in	0.000 in
SEAT_POSITION_FORE_AFT_TRAVEL	6.533 in	6.535 in	0.001 in
SEAT_POSITION_VERTICAL_TRAVEL	3.223 in	3.223 in	0.001 in
Seat Back Angle			
	UMTRI Value	TARDEC Value	Difference
SEAT_BACK_ANGLE_LOWER_QUANTILE	16.510 deg	16.507 deg	0.004 deg
SEAT_BACK_ANGLE_UPPER_QUANTILE	26.708 deg	26.712 deg	0.004 deg
Eyellipse			
	UMTRI Value	TARDEC Value	Difference
EYELLIPSE_CENTROID_X	26.716 in	26.716 in	0.000 in
EYELLIPSE_CENTROID_Y (+/-)	1.280 in	1.280 in	0.000 in
EYELLIPSE_CENTROID_Z	42.504 in	42.504 in	0.000 in
EYELLIPSE_ANGLE_REL_X	18.600 deg	18.600 deg	0.000 deg
EYELLIPSE_X_AXIS_LENGTH	6.570 in	6.573 in	0.003 in
EYELLIPSE_Y_AXIS_LENGTH	1.917 in	1.918 in	0.001 in
EYELLIPSE_Z_AXIS_LENGTH	5.236 in	5.240 in	0.004 in

Helmet Boundary			
	UMTRI Value	TARDEC Value	Difference
HELMET_CONTOUR_CBTRD_X	29.960 in	29.960 in	0.000 in
HELMET_CONTOUR_CBTRD_Y (+/-)	2.185 in	2.185 in	0.000 in
HELMET_CONTOUR_CBTRD_Z	44.921 in	44.921 in	0.000 in
HELMET_CONTOUR_X_AXIS_LENGTH	17.045 in	17.048 in	0.003 in
HELMET_CONTOUR_Y_AXIS_LENGTH	9.515 in	9.517 in	0.001 in
HELMET_CONTOUR_Z_AXIS_LENGTH	13.292 in	13.296 in	0.004 in
Knee Boundary			
	UMTRI Value	TARDEC Value	Difference
KNEE_CONTOUR_WEIGHTED_CENT_X	10.112 in	10.112 in	0.000 in
KNEE_CONTOUR_WEIGHTED_CENT_Y (+/-)	7.331 in	7.331 in	0.000 in
KNEE_CONTOUR_WEIGHTED_CENT_Z	19.772 in	19.772 in	0.000 in
KNEE_CONTOUR_X_AXIS_LENGTH	7.611 in	7.613 in	0.002 in
KNEE_CONTOUR_Y_AXIS_LENGTH	8.671 in	8.673 in	0.001 in
KNEE_CONTOUR_Z_AXIS_LENGTH	6.317 in	6.317 in	0.000 in
KNEE_SHRN_ANGLE	29.013 deg	29.013 deg	0.000 deg
KNEE_THIGH_ANGLE	10.322 deg	10.322 deg	0.000 deg
Torso Boundary			
	UMTRI Value	TARDEC Value	Difference
TORSO_WEIGHTED_REF_PT_PFE_X	22.289 in	22.288 in	0.001 in
TORSO_WEIGHTED_REF_PT_PFE_Z	33.449 in	33.449 in	0.000 in
Elbow Boundary			
	UMTRI Value	TARDEC Value	Difference
ELBOW_WEIGHTED_CBNT_X	29.717 in	29.717 in	0.000 in
ELBOW_WEIGHTED_CBNT_Y (+/-)	12.353 in	12.353 in	0.000 in
ELBOW_WEIGHTED_CBNT_Z	21.989 in	21.989 in	0.000 in
ELBOW_X_AXIS_LENGTH	7.303 in	7.305 in	0.002 in
ELBOW_Y_AXIS_LENGTH	3.424 in	3.425 in	0.001 in
ELBOW_Z_AXIS_LENGTH	5.665 in	5.668 in	0.003 in

TARDEC CAD values to agree with UMTRI spreadsheet values within
 ±0.100 inches
 ±0.100 degrees

Largest Observed Differences:
 0.004 inches
 0.004 degrees

Values in agreement

Test #3: Surrogate Steering Wheel

UMTRI Spreadsheet Calculations

	L11	H17
	(in)	(in)
Steering Wheel Point (SWP)	13.300	29.000

TARDEC CAD Model Calculations

STEERING_WHEEL_X	13.300	in
STEERING_WHEEL_Z	29.000	in

TARDEC CAD Model Geometry

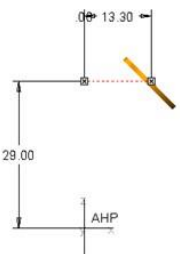

Side View

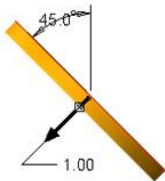

Side View

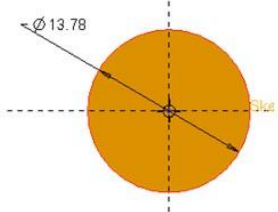

Normal to Steering Wheel

Steering Wheel Geometry

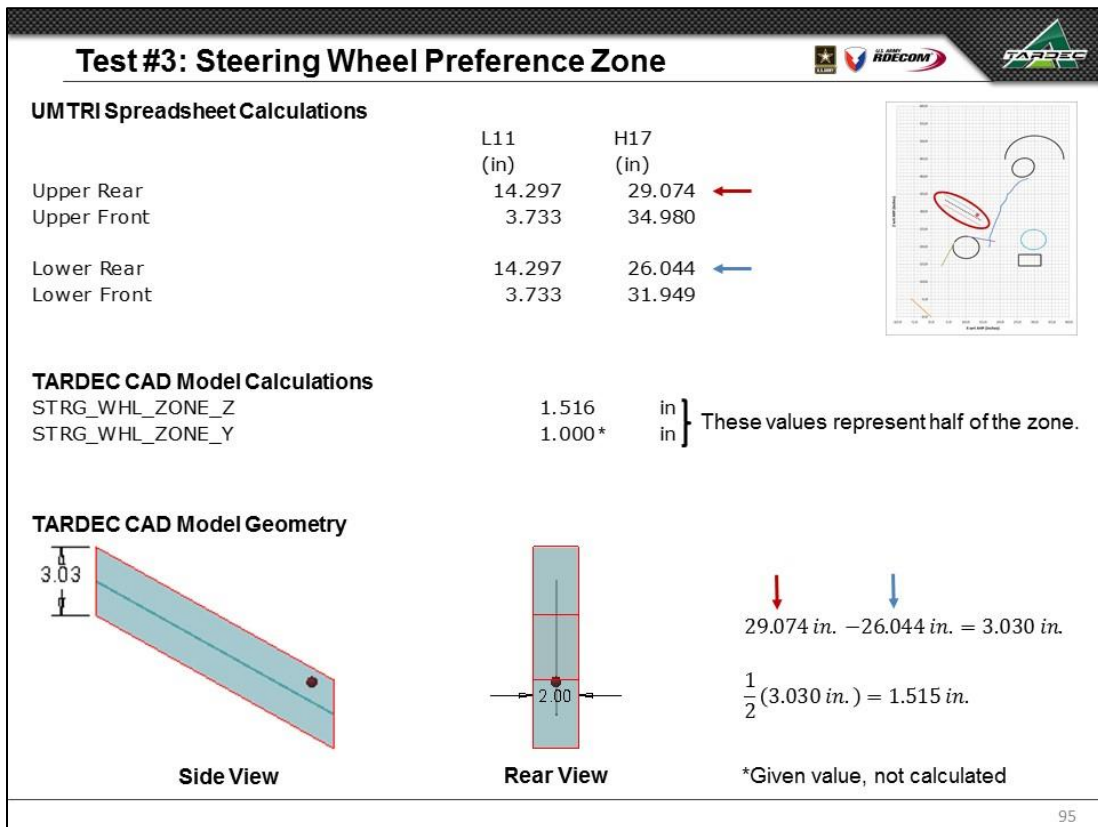
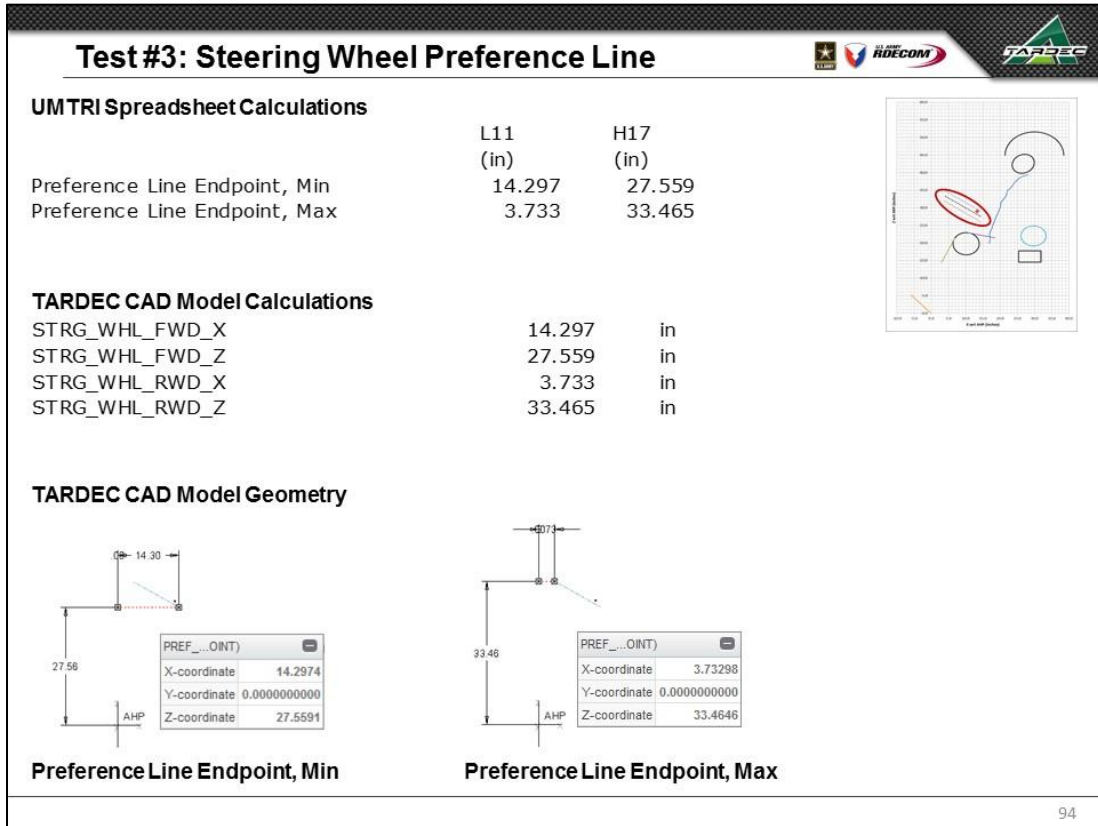

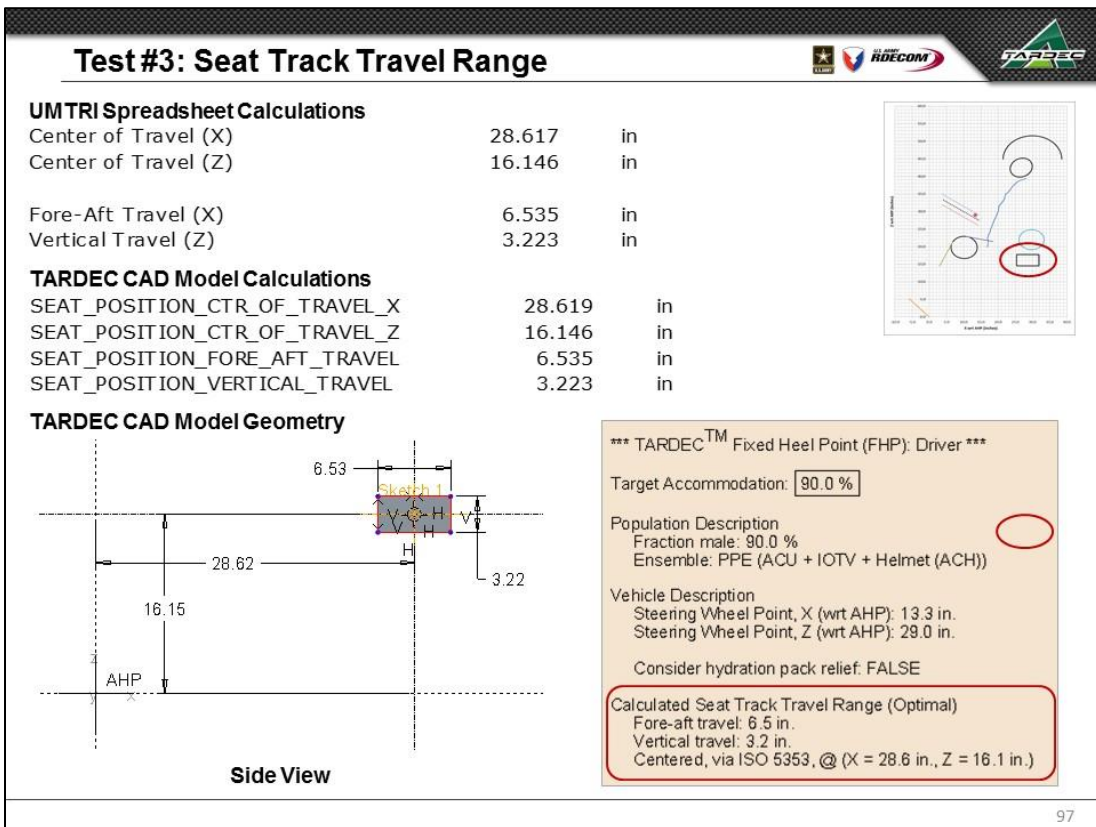
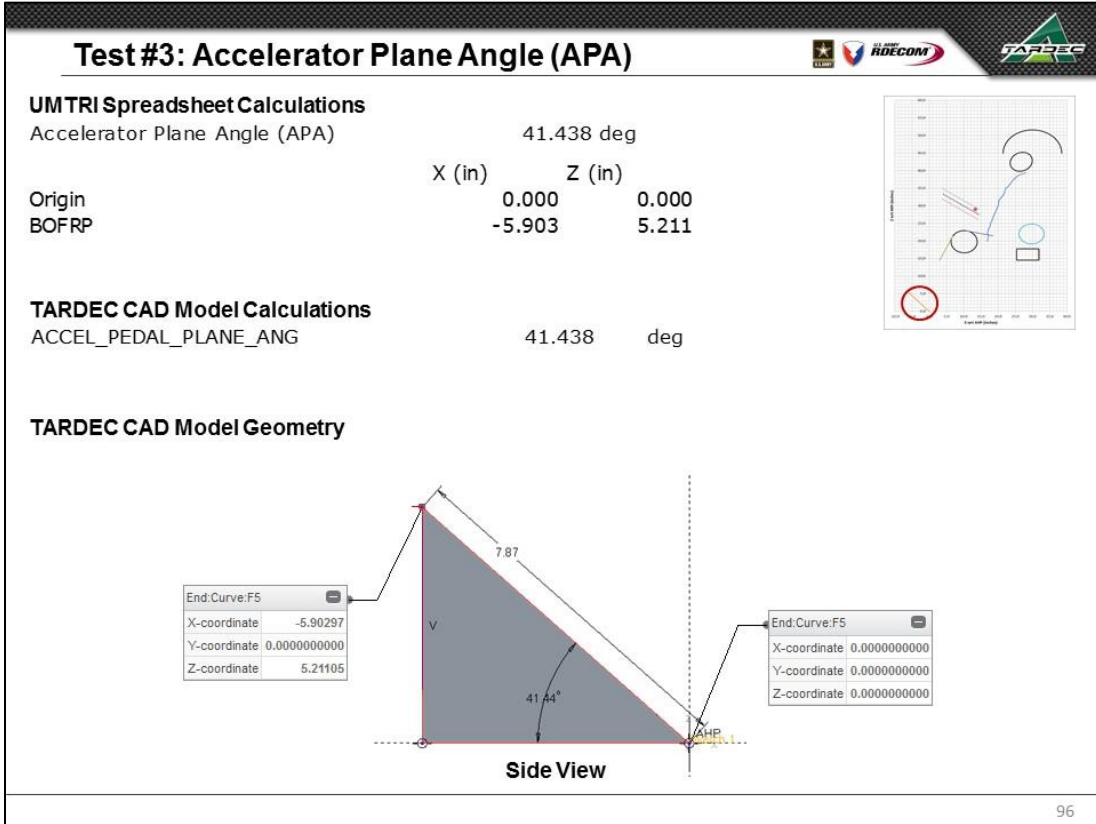

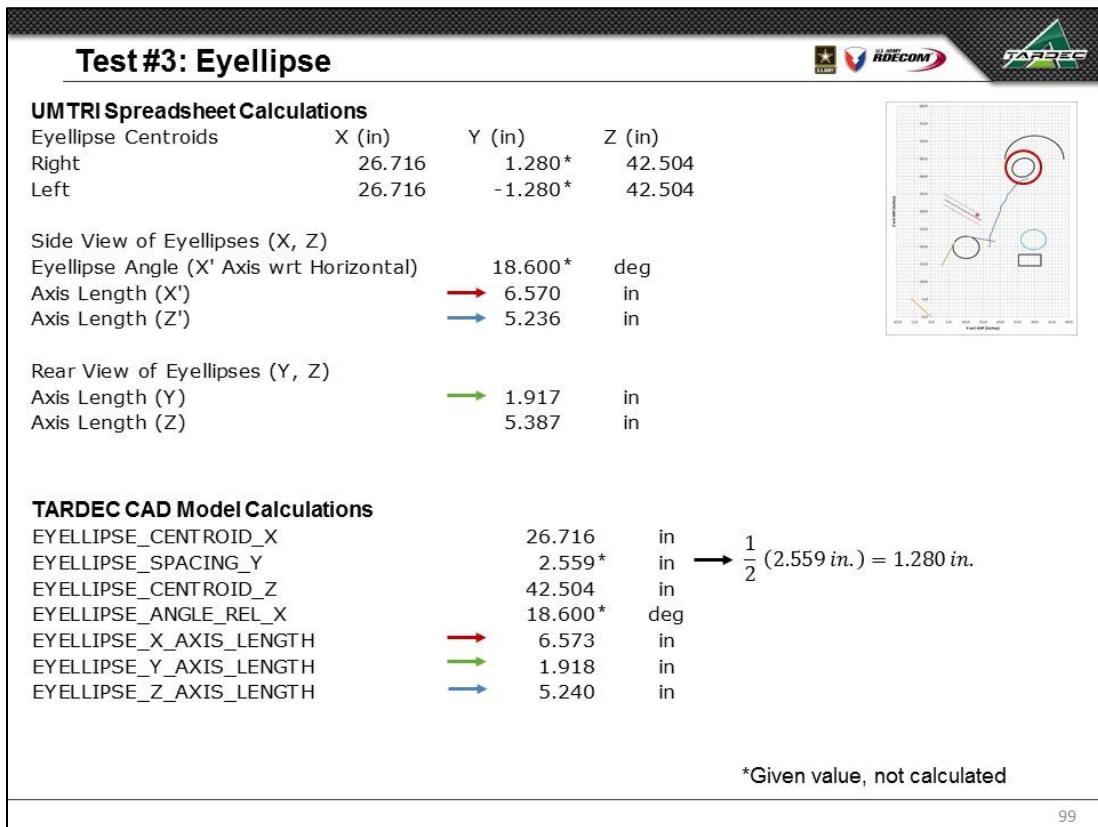
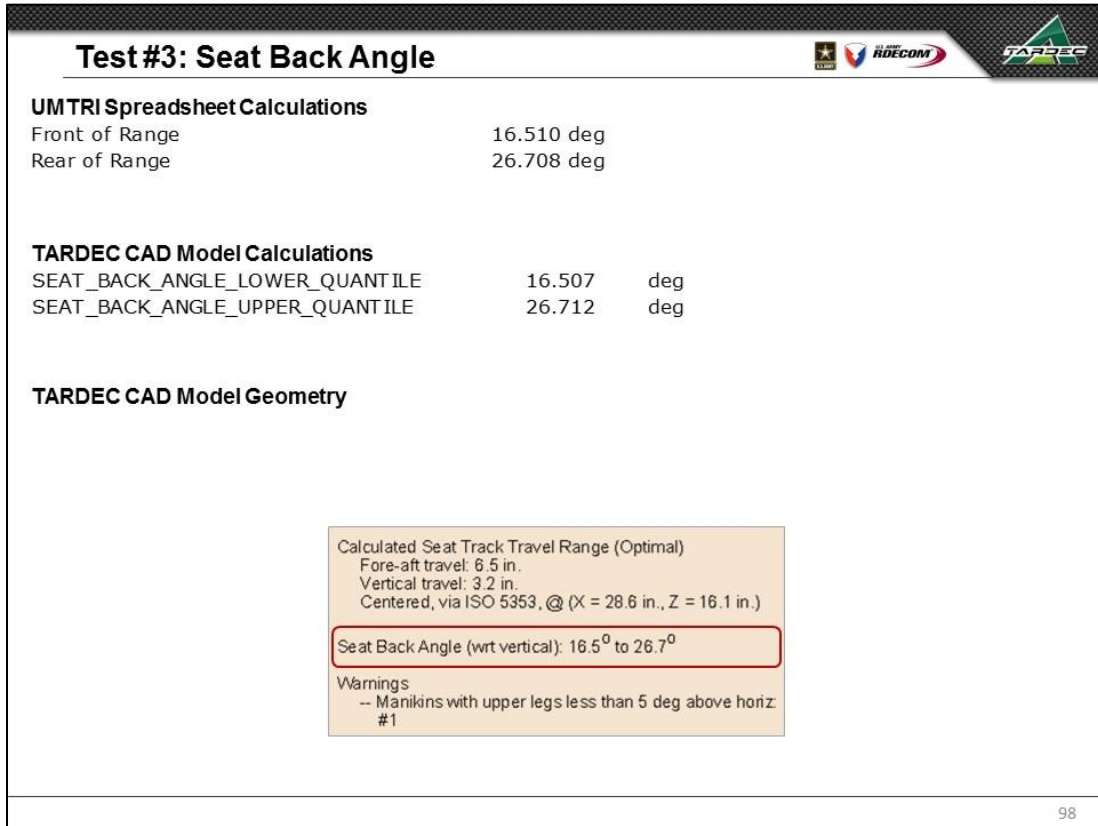

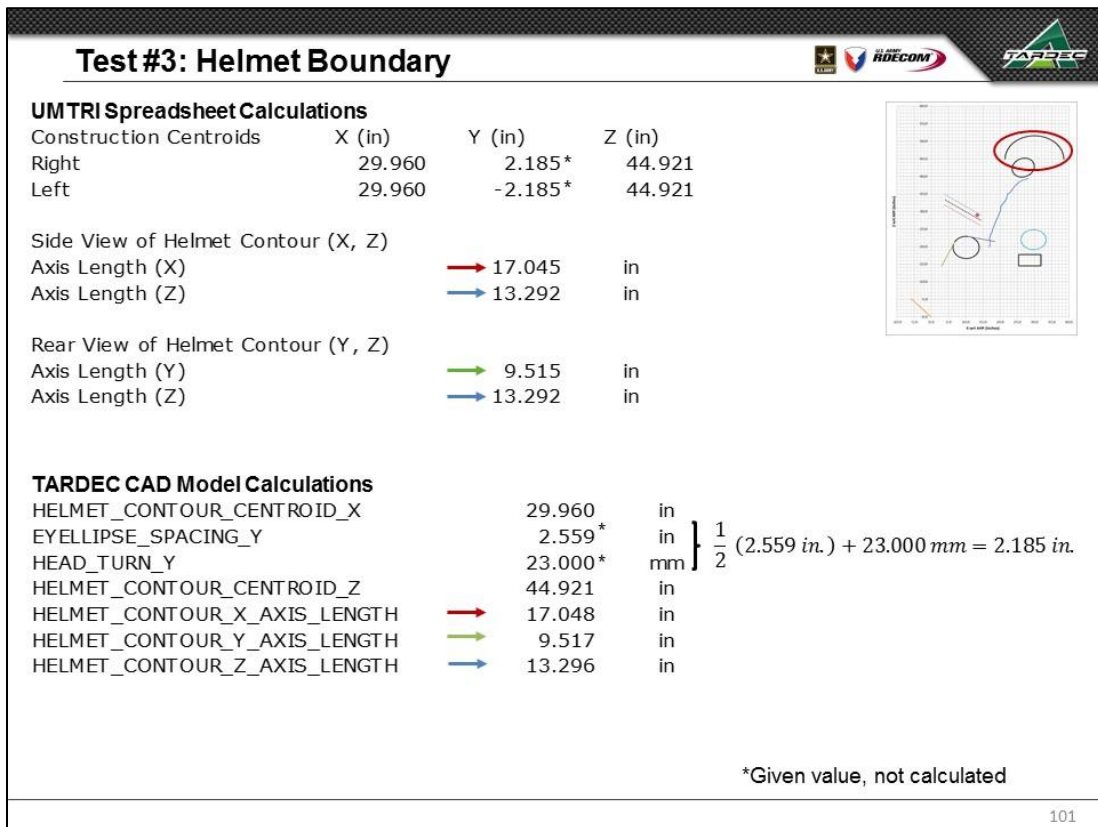
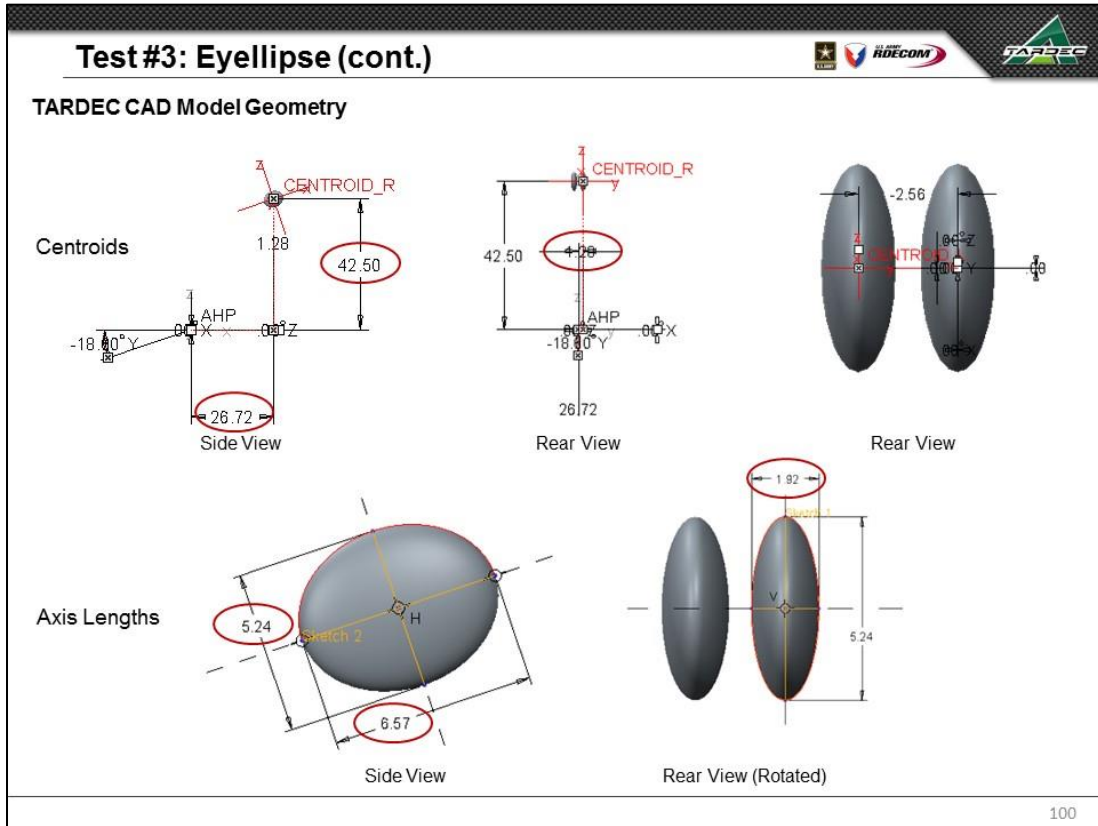

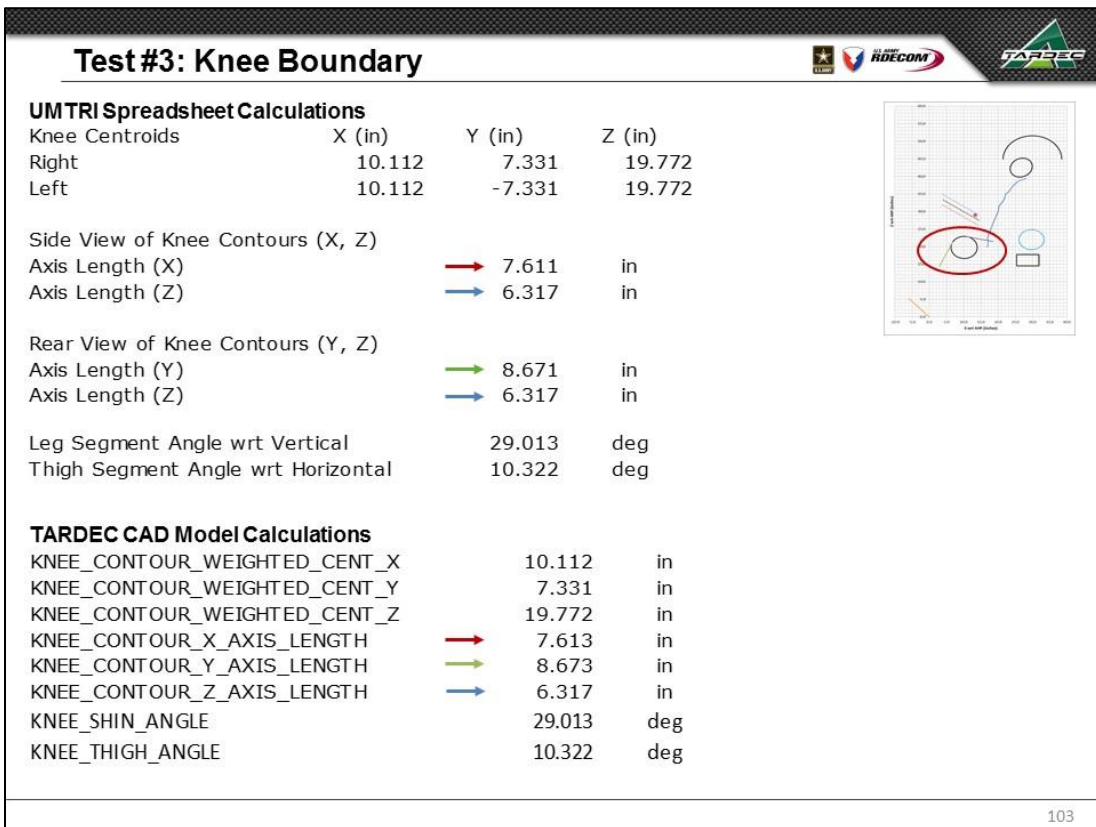
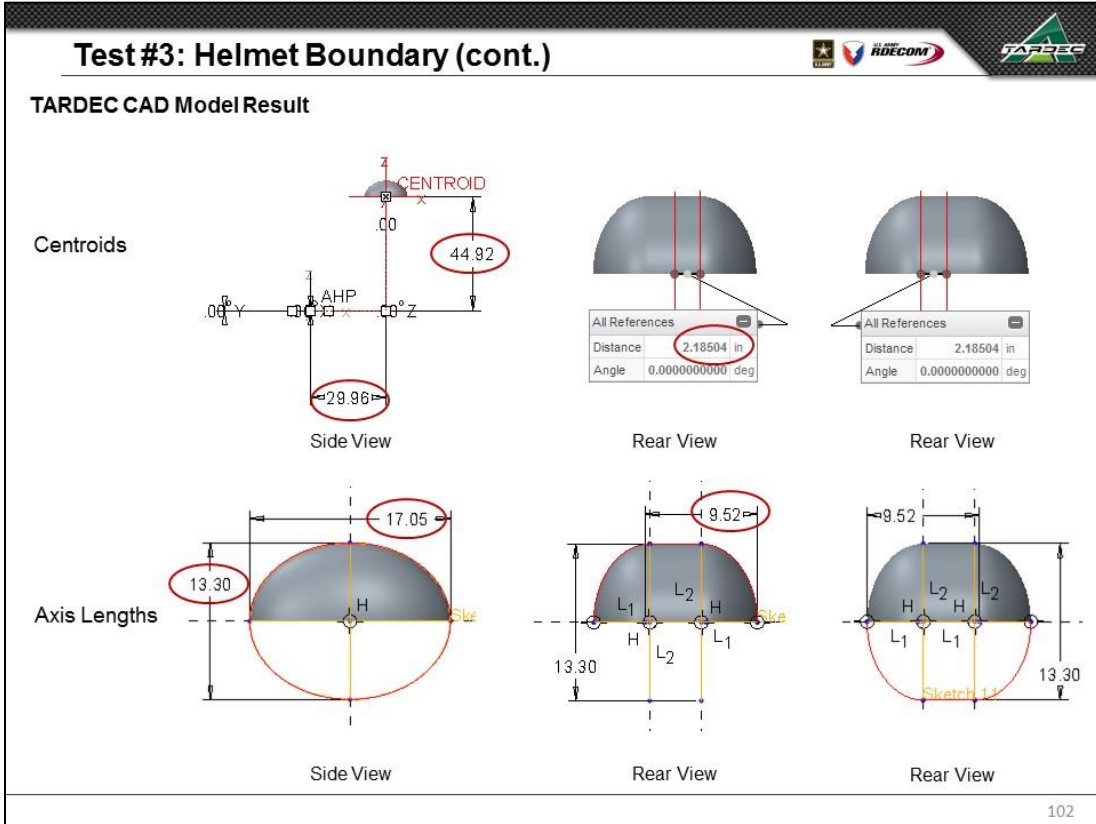

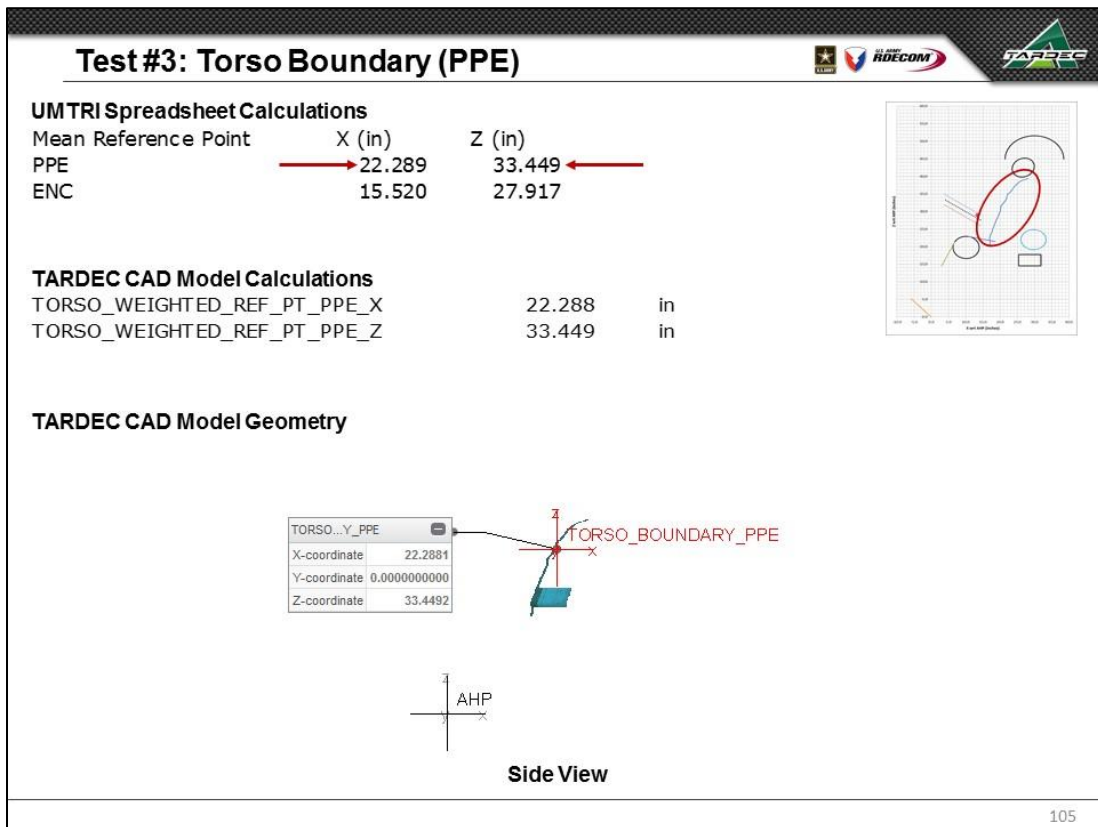
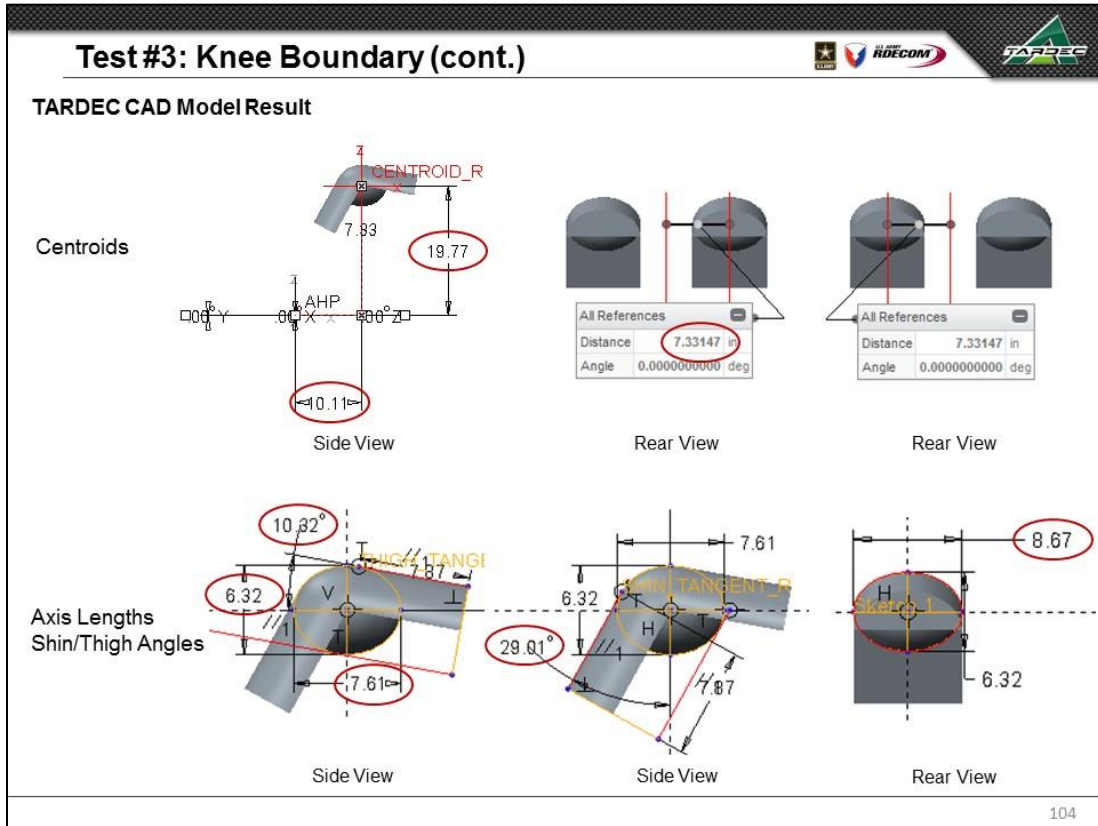

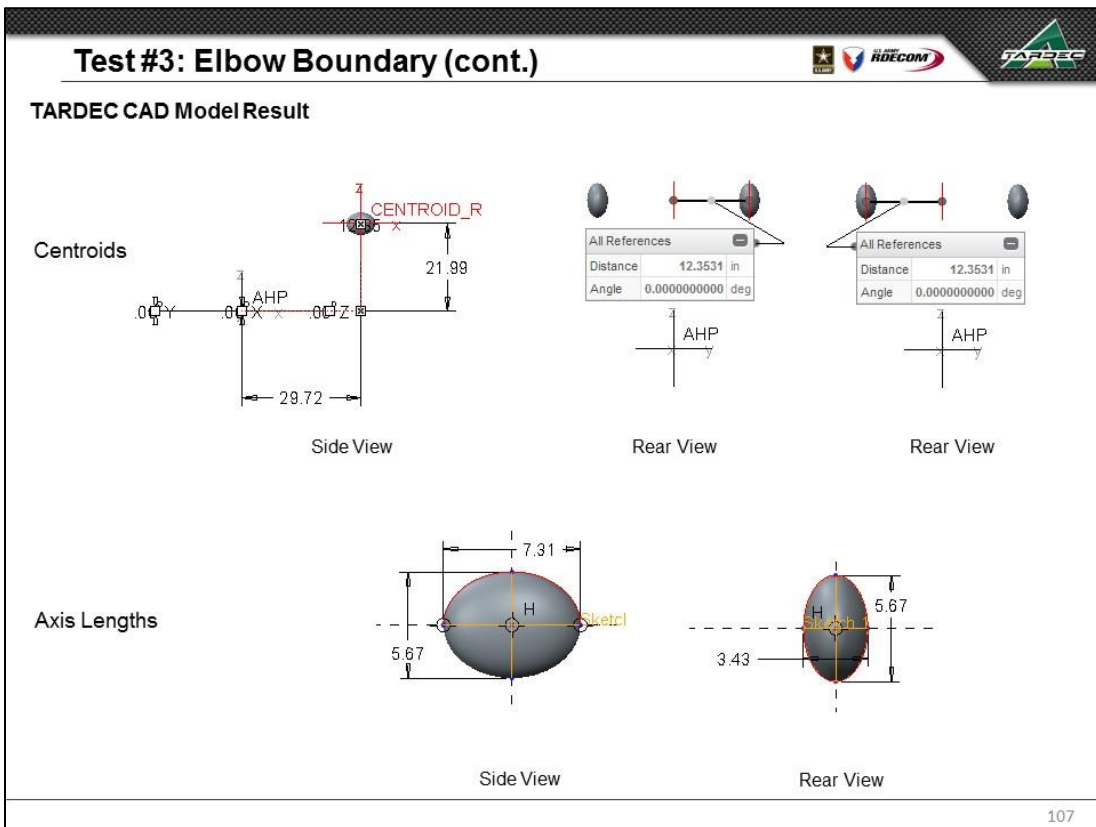
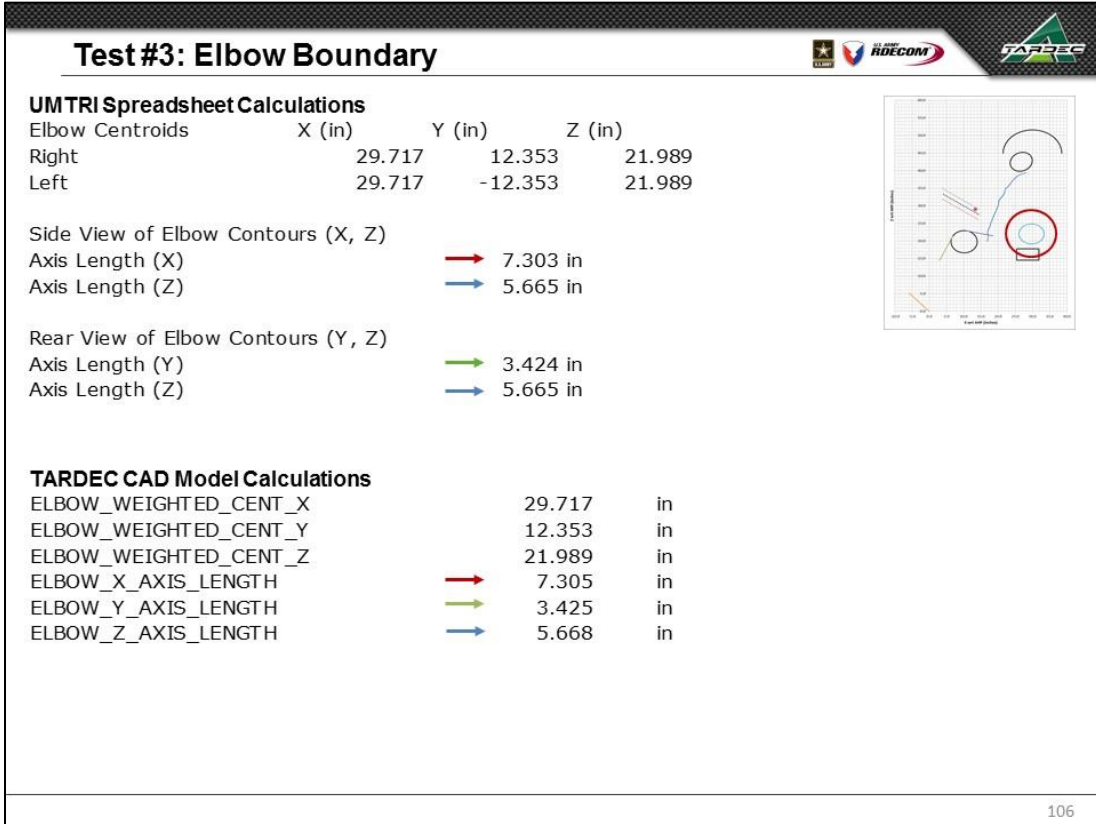

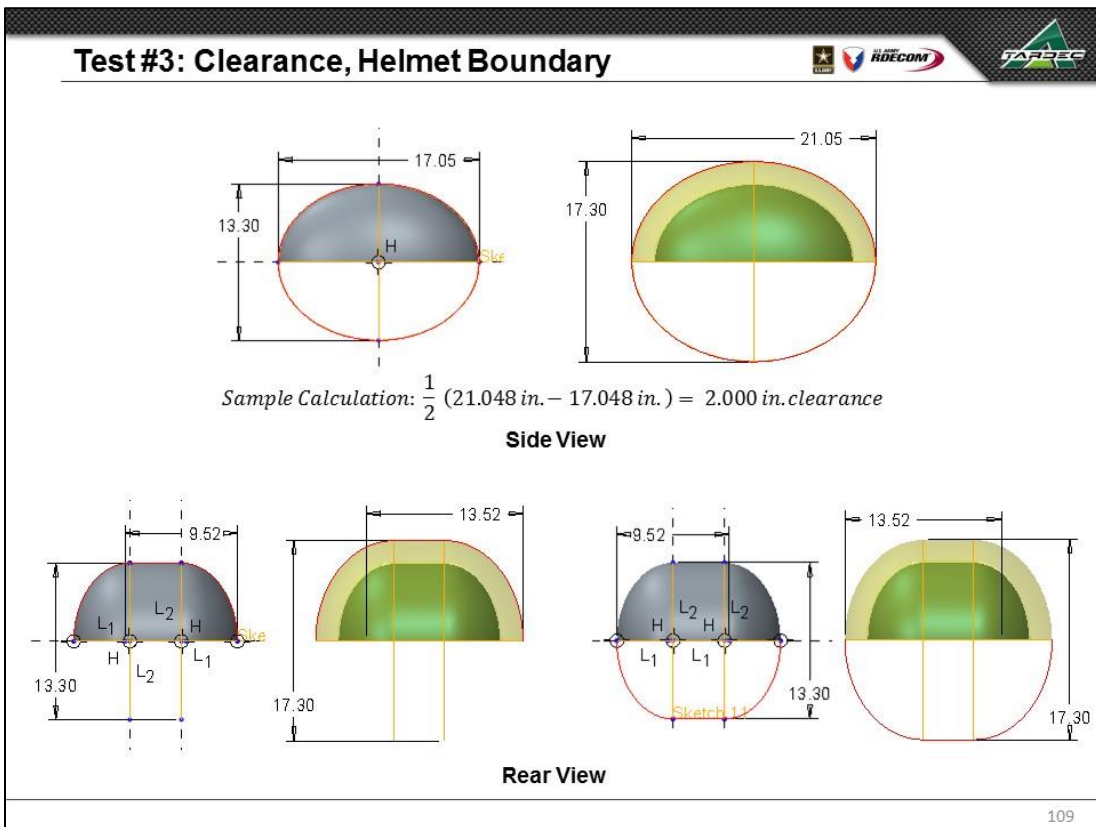
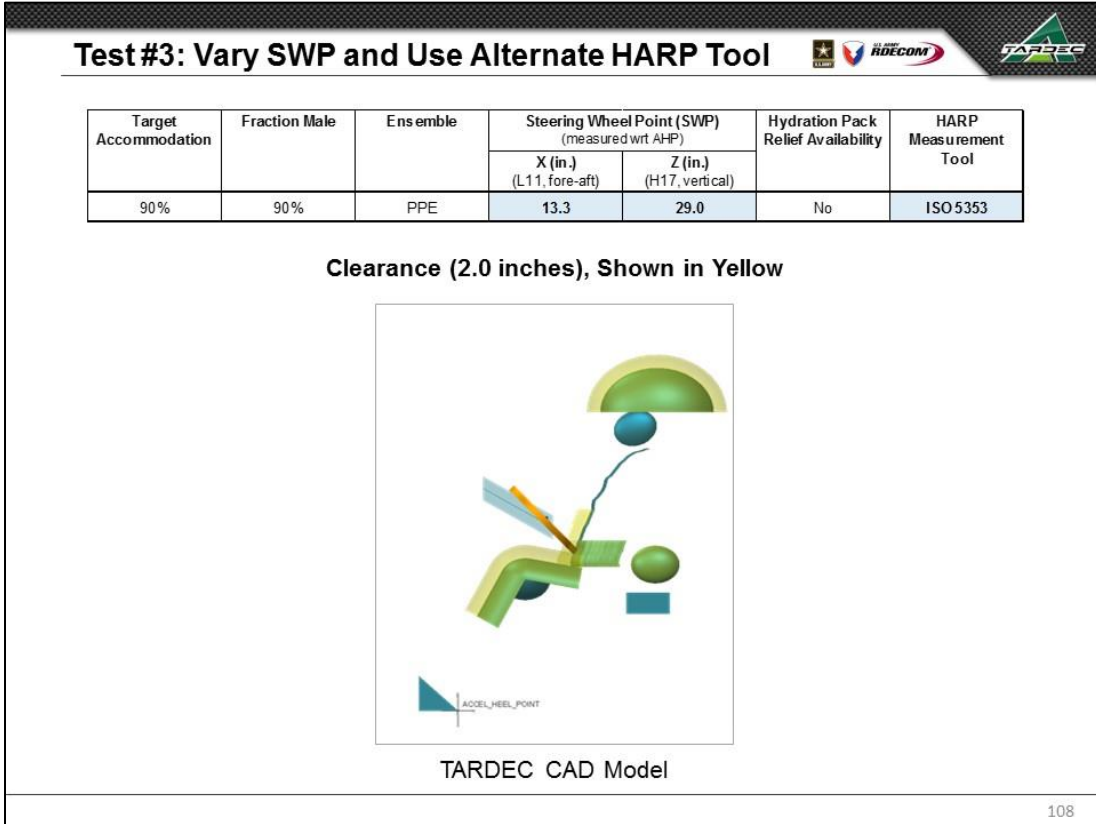

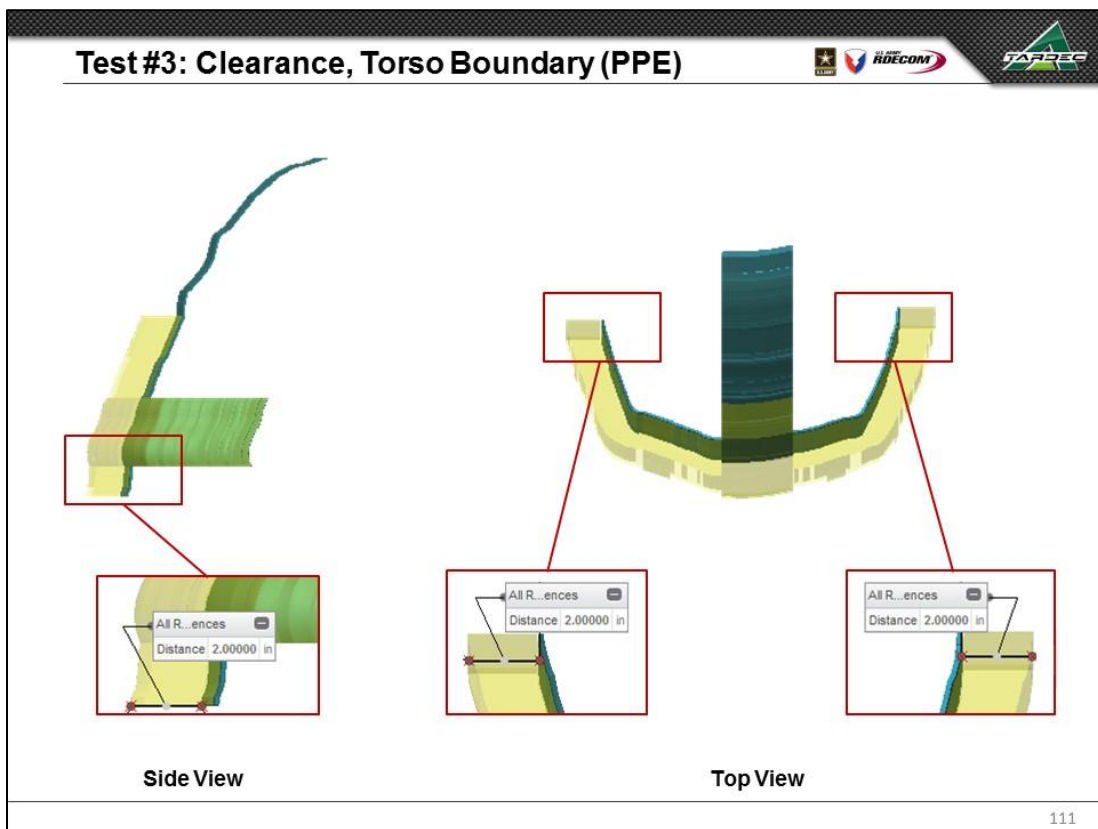
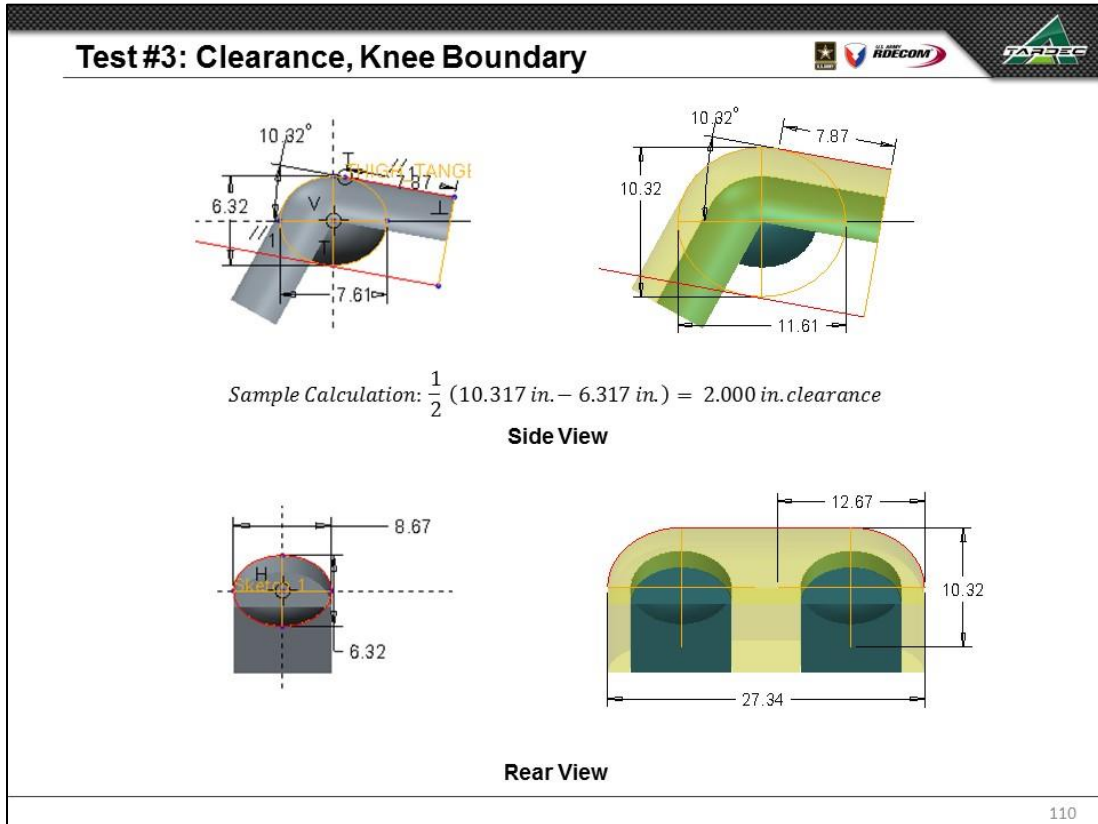

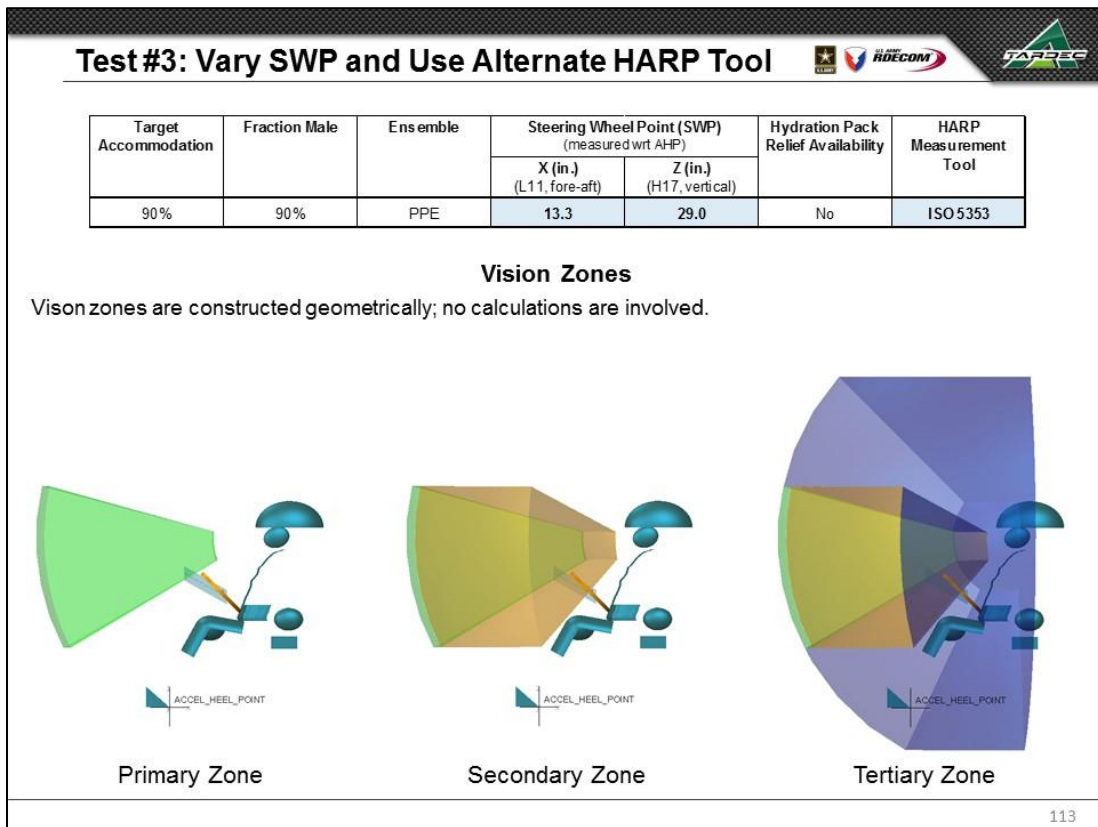
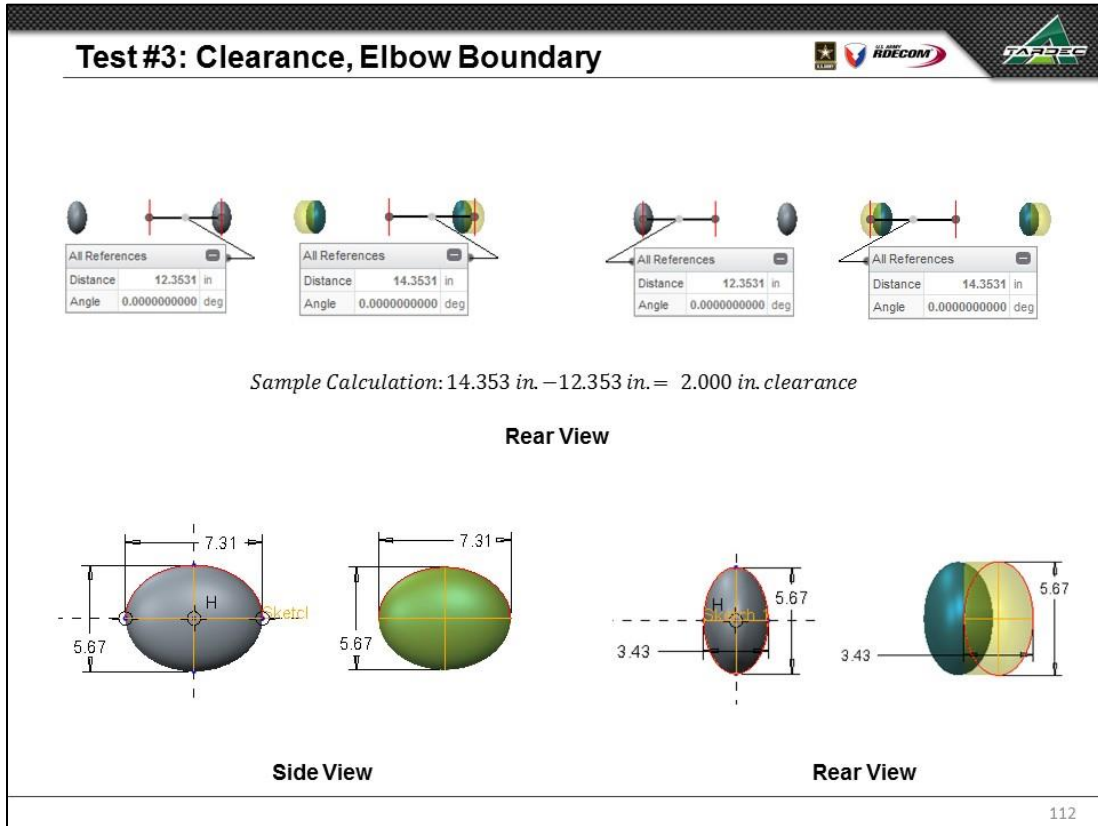

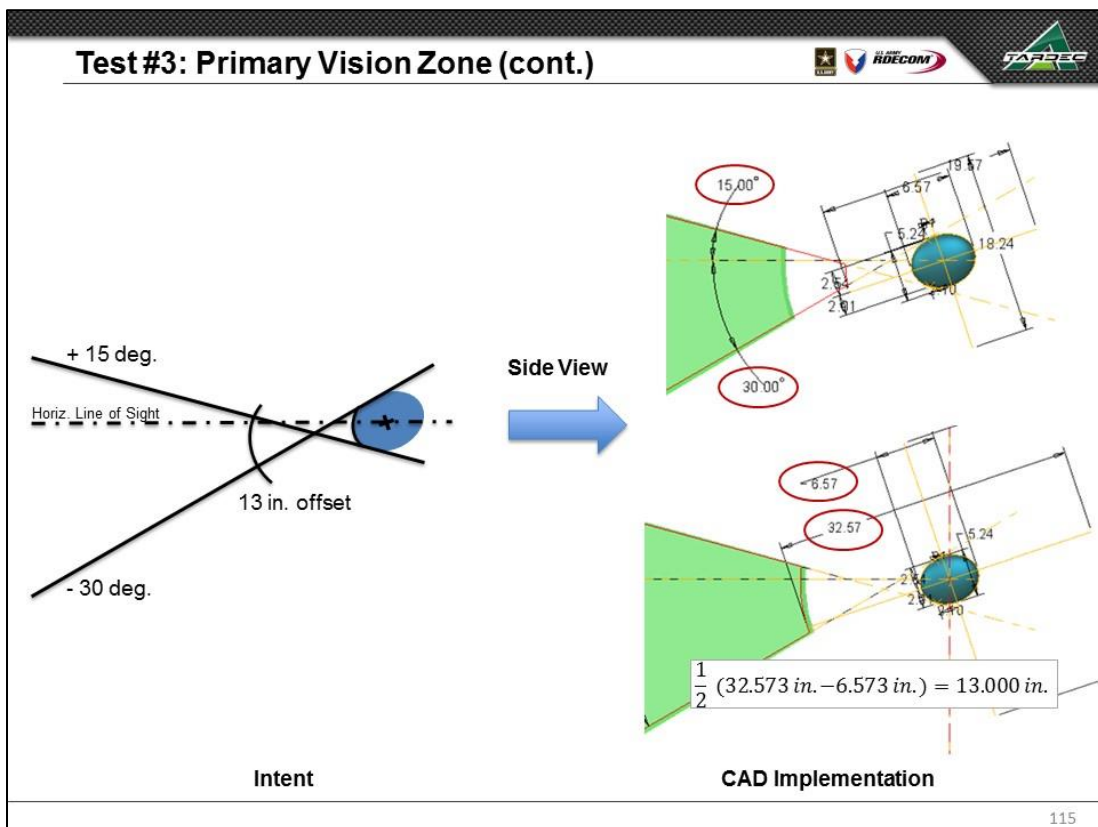
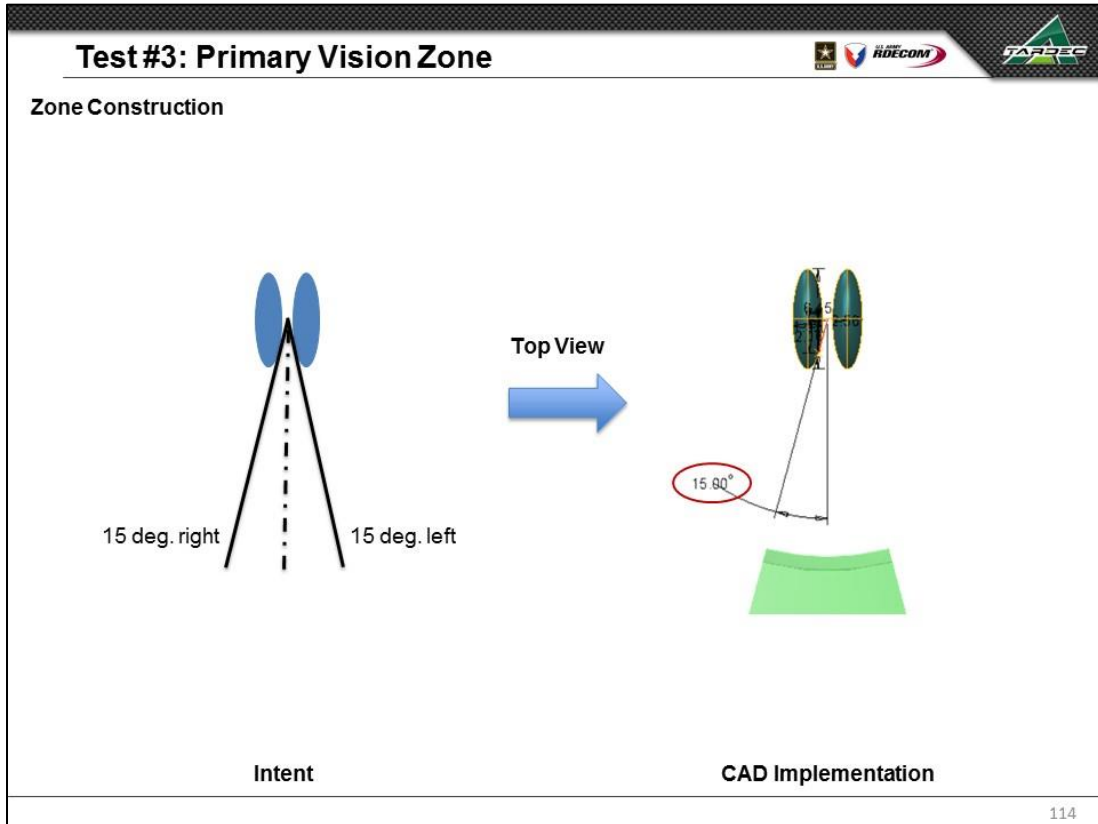

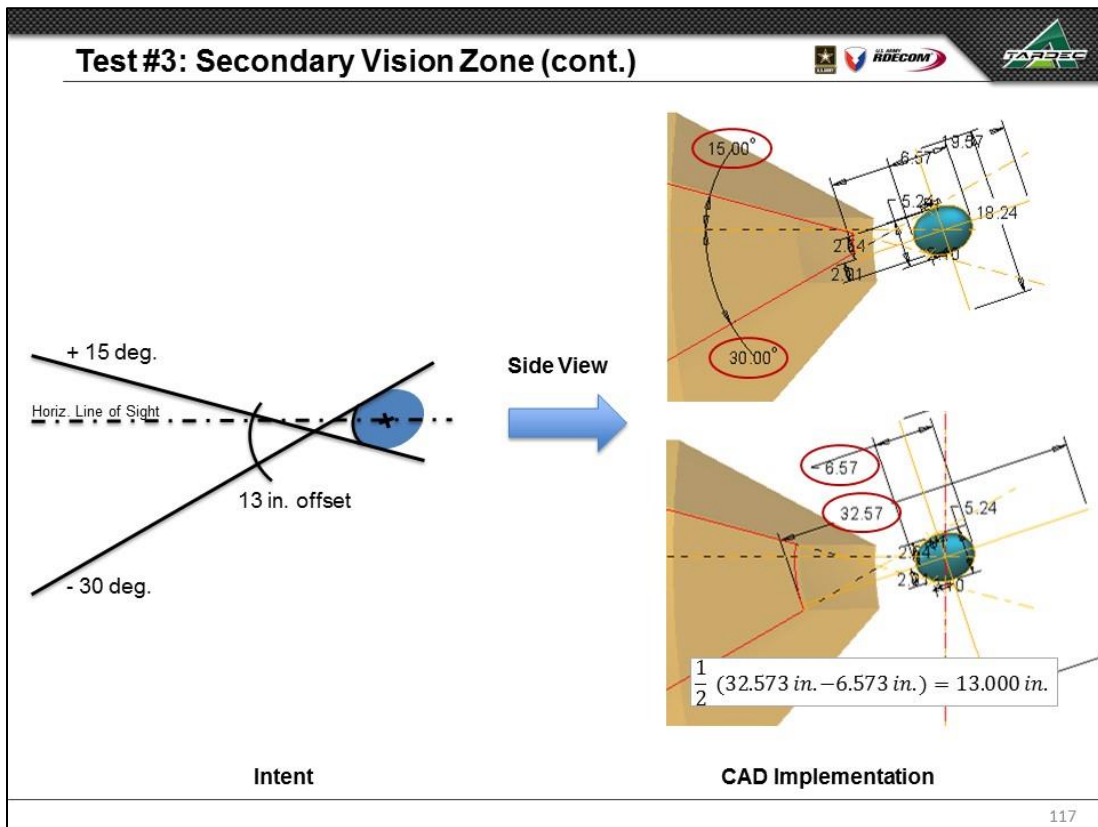
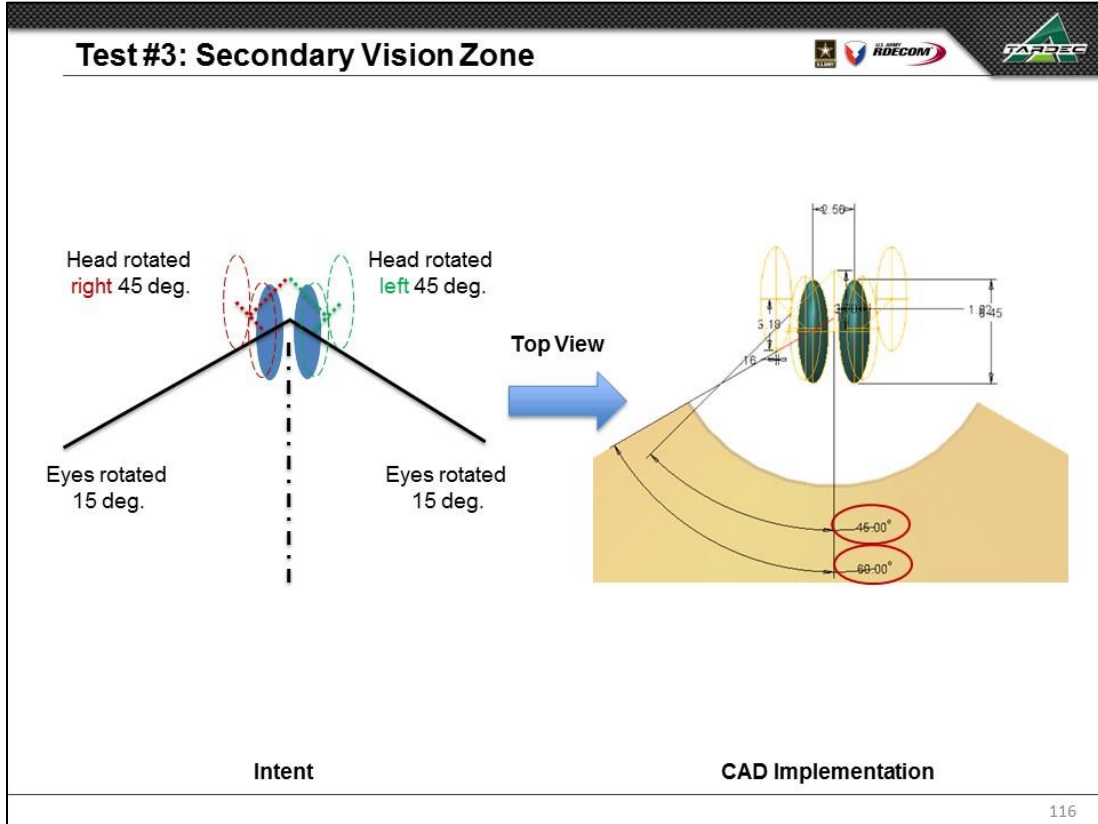

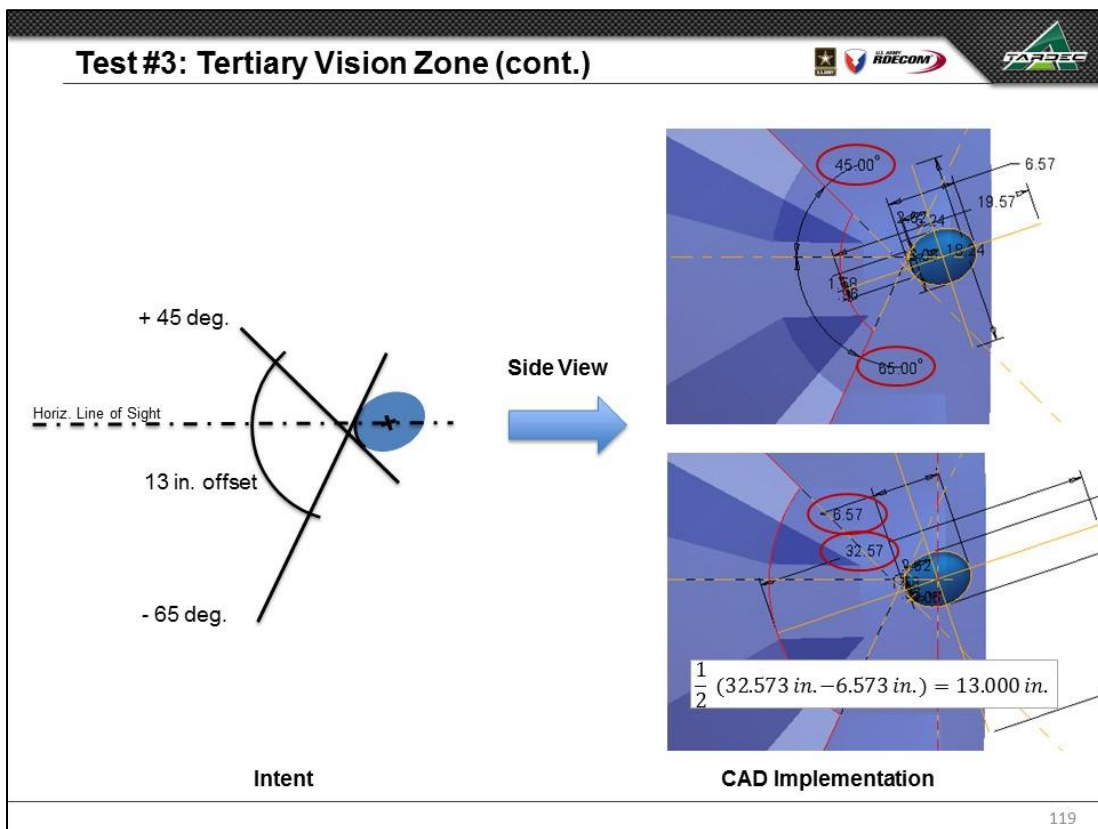
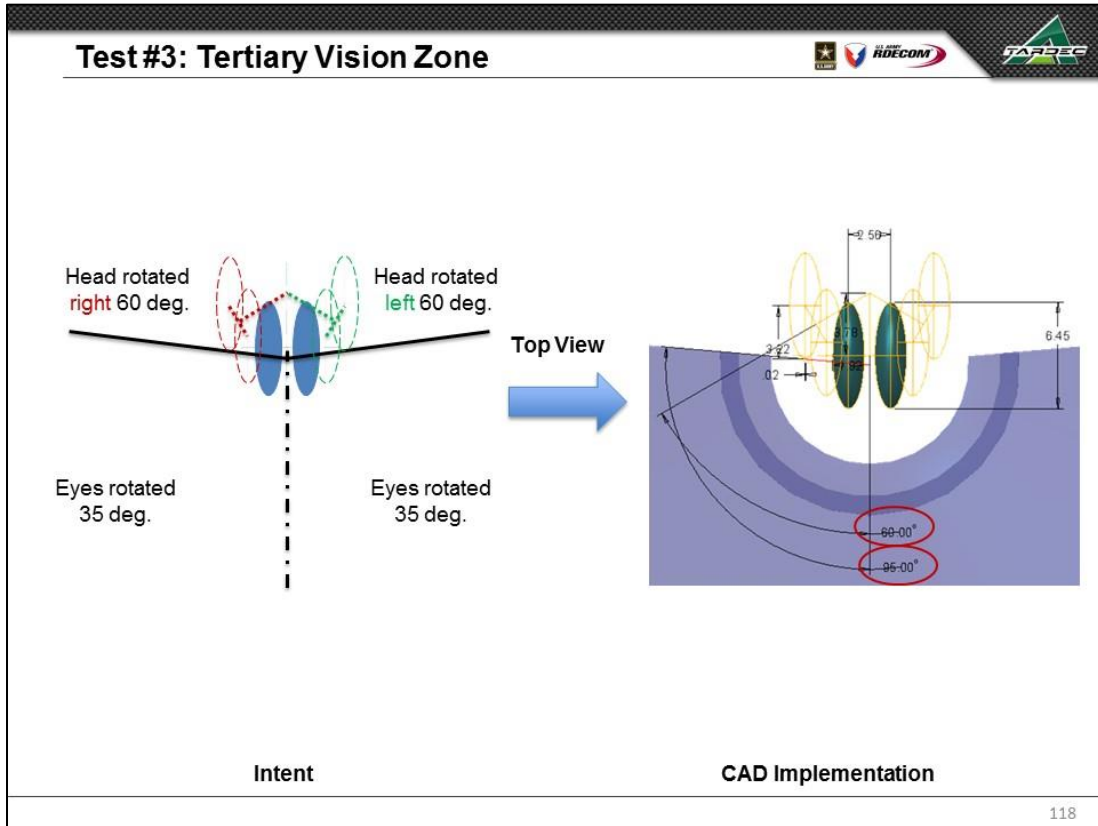



Test #3: Vary SWP and Use Alternate HARP Tool

Target Accommodation	Fraction Male	Ensemble	Steering Wheel Point (SWP) (measured wrt AHP)		Hydration Pack Relief Availability	HARP Measurement Tool
			X (in.) (L11, fore-aft)	Z (in.) (H17, vertical)		
90%	90%	PPE	13.3	29.0	No	ISO 5353

Boundary Manikin Posture and Position



TARDEC CAD Model

120

Test #3: Numerical Results, Manikin Positioning

Small Overall Female			
	UMTRI Value	TARDEC Value	Difference
POSTURE_DHM1_HIP_X	23.660 in	23.660 in	0.000 in
POSTURE_DHM1_HIP_Z	15.879 in	15.879 in	0.000 in
POSTURE_DHM1_EYE_X	24.940 in	24.940 in	0.000 in
POSTURE_DHM1_EYE_Z	38.171 in	38.171 in	0.000 in
Small Overall Male			
	UMTRI Value	TARDEC Value	Difference
POSTURE_DHM2_HIP_X	25.782 in	25.782 in	0.000 in
POSTURE_DHM2_HIP_Z	15.989 in	15.989 in	0.000 in
POSTURE_DHM2_EYE_X	26.191 in	26.191 in	0.000 in
POSTURE_DHM2_EYE_Z	39.938 in	39.938 in	0.000 in
Average Size Male			
	UMTRI Value	TARDEC Value	Difference
POSTURE_DHM3_HIP_X	27.977 in	27.977 in	0.000 in
POSTURE_DHM3_HIP_Z	15.988 in	15.988 in	0.000 in
POSTURE_DHM3_EYE_X	27.599 in	27.599 in	0.000 in
POSTURE_DHM3_EYE_Z	42.162 in	42.162 in	0.000 in
Widest Shoulders Male			
	UMTRI Value	TARDEC Value	Difference
POSTURE_DHM4_HIP_X	28.985 in	28.986 in	0.000 in
POSTURE_DHM4_HIP_Z	15.977 in	15.977 in	0.000 in
POSTURE_DHM4_EYE_X	28.255 in	28.256 in	0.000 in
POSTURE_DHM4_EYE_Z	43.440 in	43.440 in	0.000 in
Longest Torso Male			
	UMTRI Value	TARDEC Value	Difference
POSTURE_DHM5_HIP_X	28.229 in	28.229 in	0.000 in
POSTURE_DHM5_HIP_Z	15.971 in	15.971 in	0.000 in
POSTURE_DHM5_EYE_X	27.765 in	27.765 in	0.000 in
POSTURE_DHM5_EYE_Z	44.441 in	44.441 in	0.000 in
Longest Legs Male			
	UMTRI Value	TARDEC Value	Difference
POSTURE_DHM6_HIP_X	30.501 in	30.502 in	0.000 in
POSTURE_DHM6_HIP_Z	16.042 in	16.042 in	0.000 in
POSTURE_DHM6_EYE_X	29.176 in	29.176 in	0.000 in
POSTURE_DHM6_EYE_Z	42.661 in	42.661 in	0.000 in
Large Overall Male			
	UMTRI Value	TARDEC Value	Difference
POSTURE_DHM7_HIP_X	30.327 in	30.327 in	0.000 in
POSTURE_DHM7_HIP_Z	16.139 in	16.139 in	0.000 in
POSTURE_DHM7_EYE_X	28.932 in	28.932 in	0.000 in
POSTURE_DHM7_EYE_Z	44.400 in	44.400 in	0.000 in

TARDEC CAD values to agree with UMTRI spreadsheet values within
 ±0.100 inches
 ±0.100 degrees

Largest Observed Differences:
 0.000 inches

Values in agreement

121

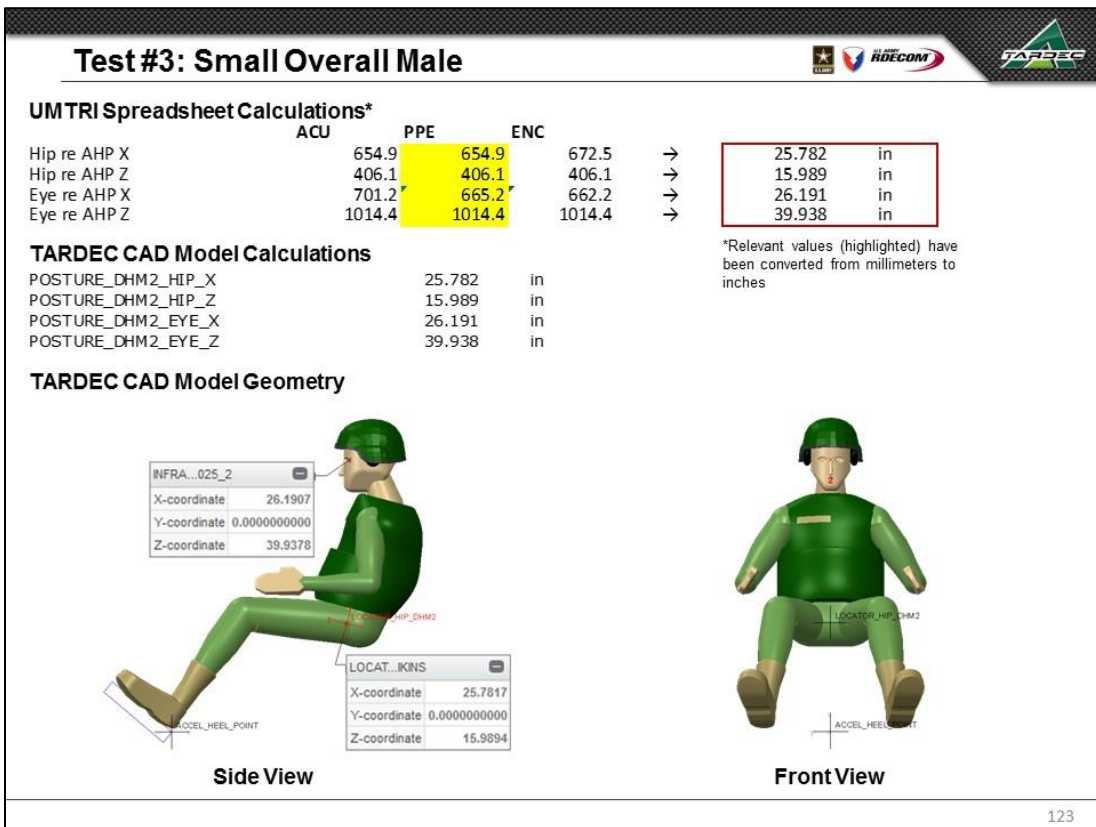
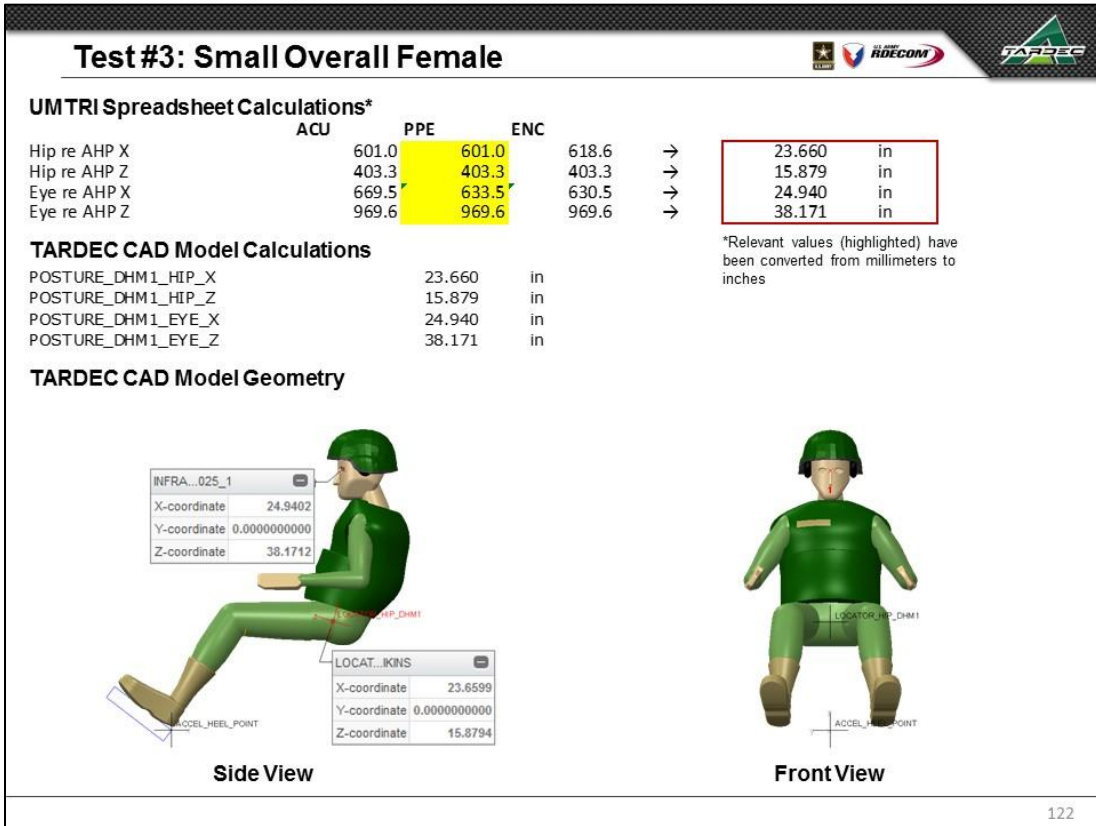

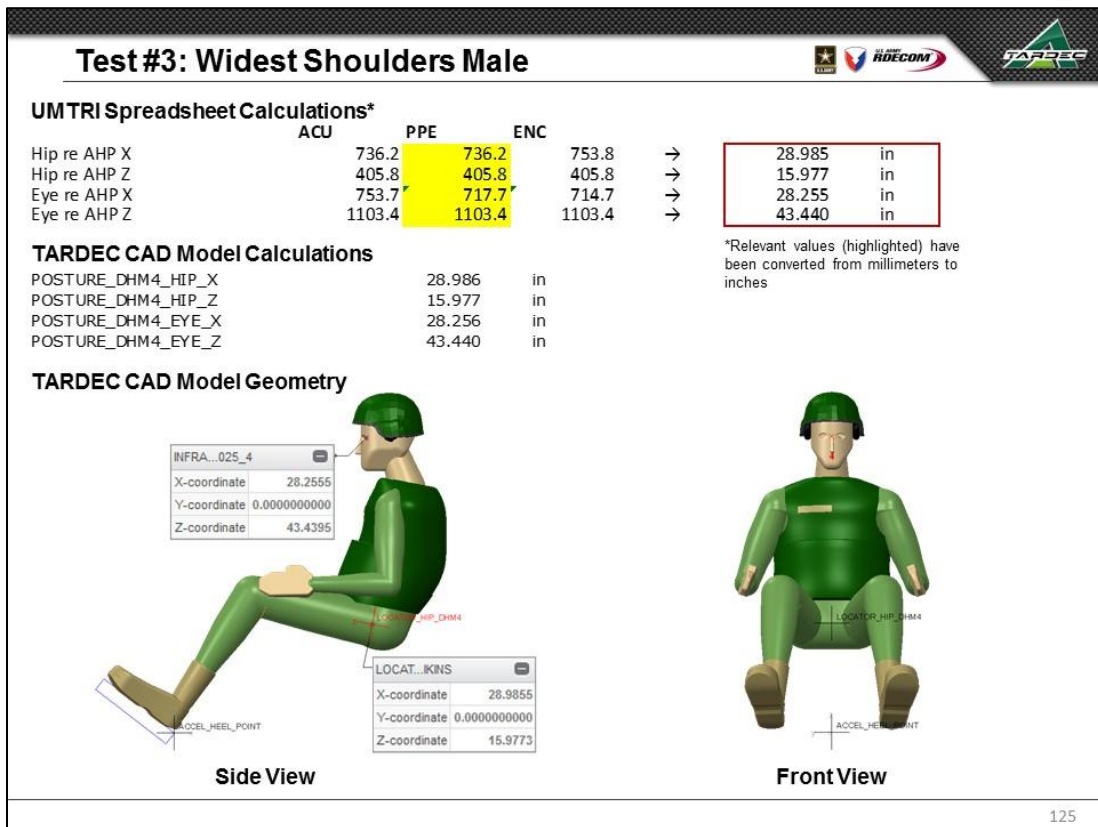
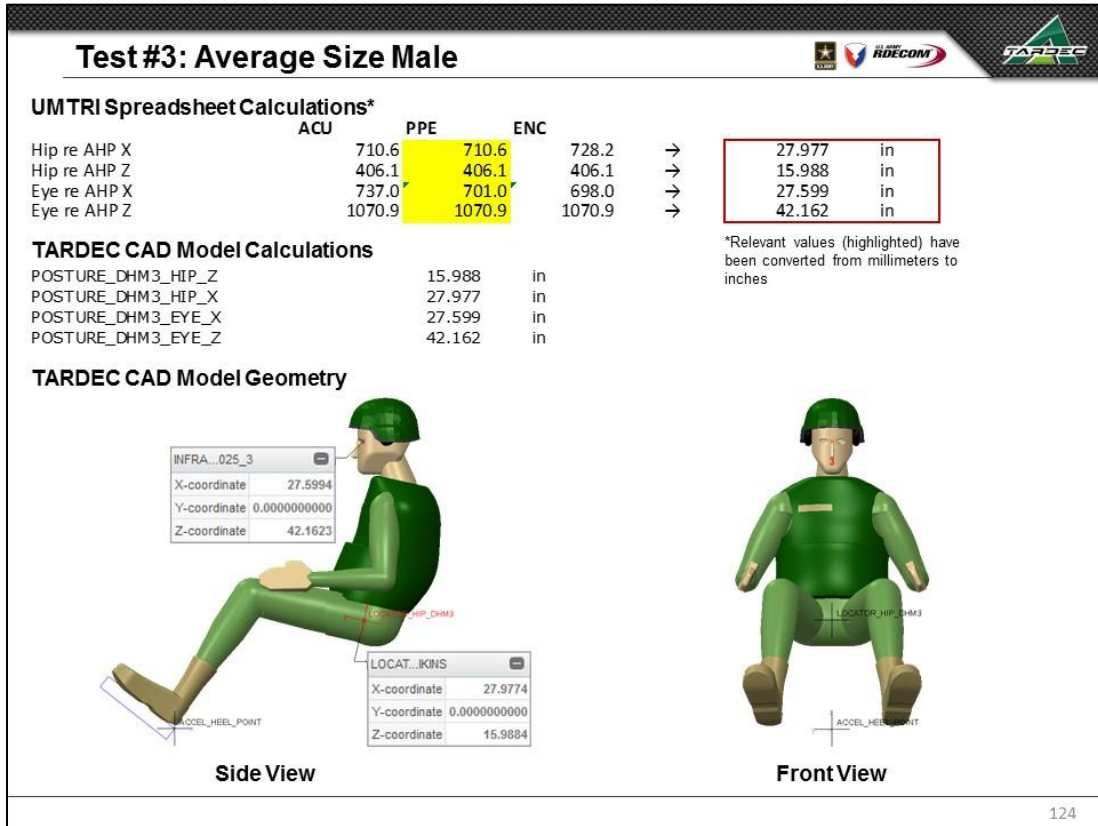

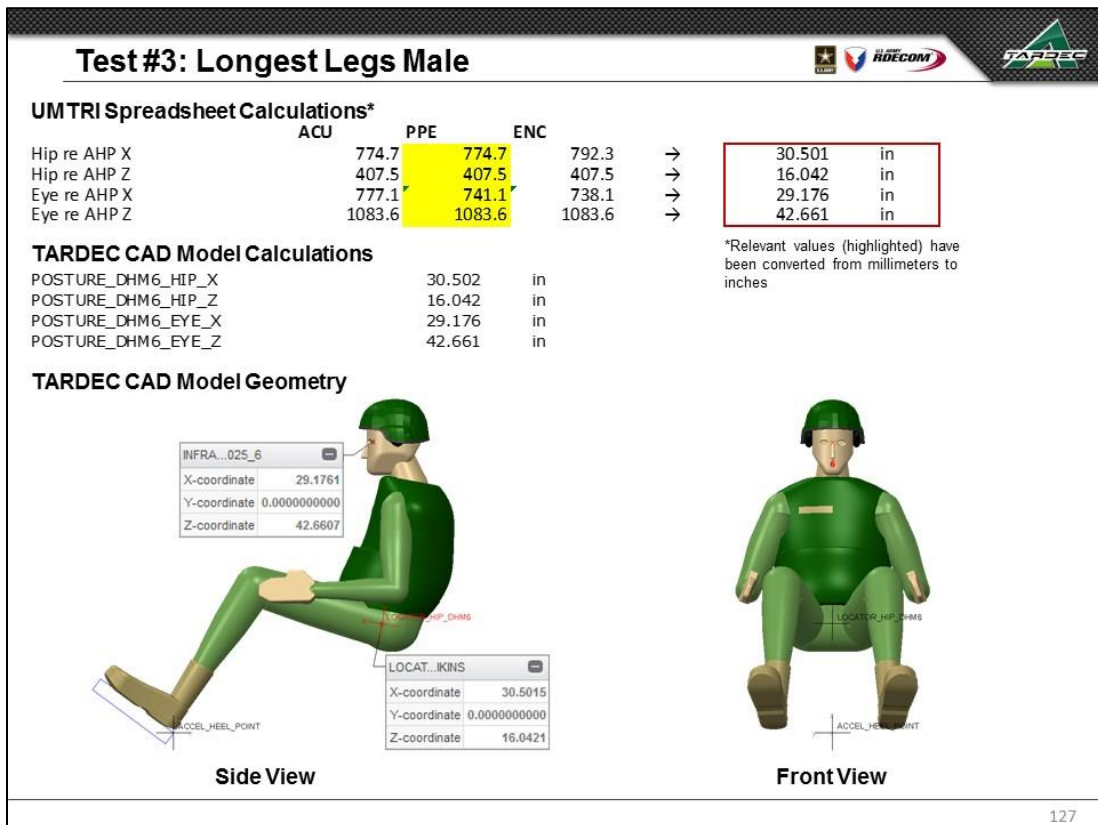
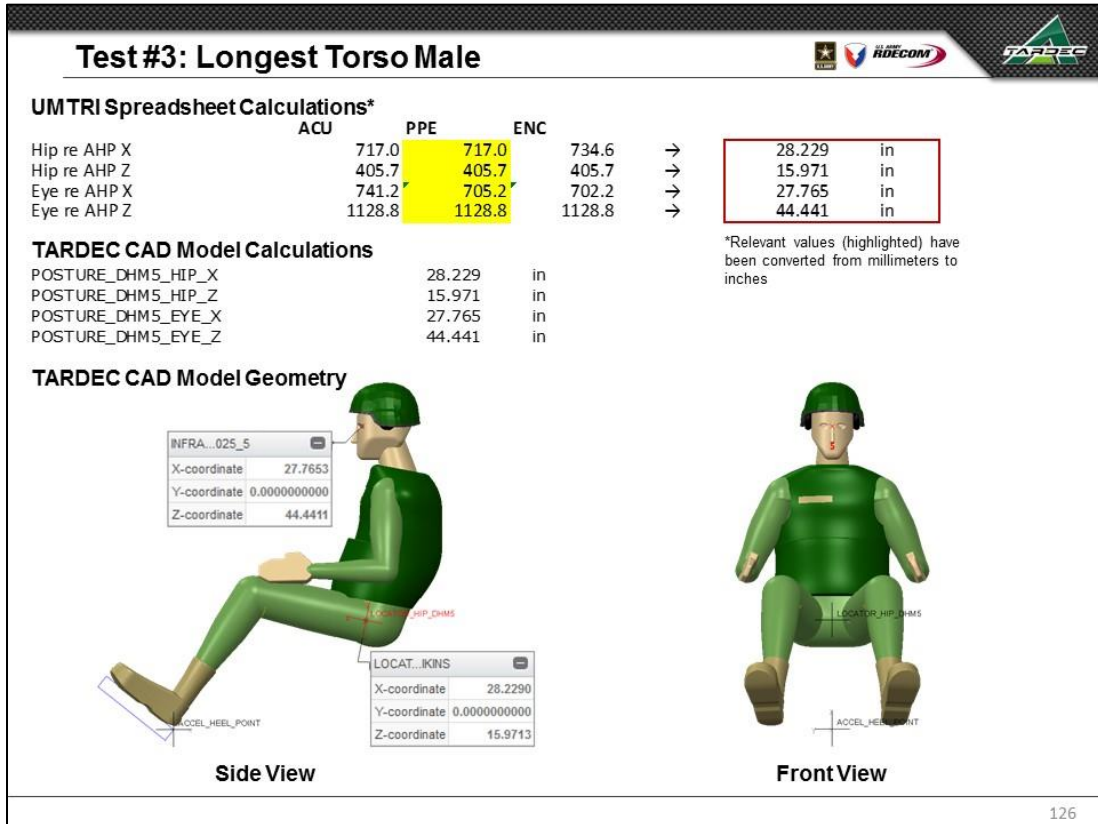

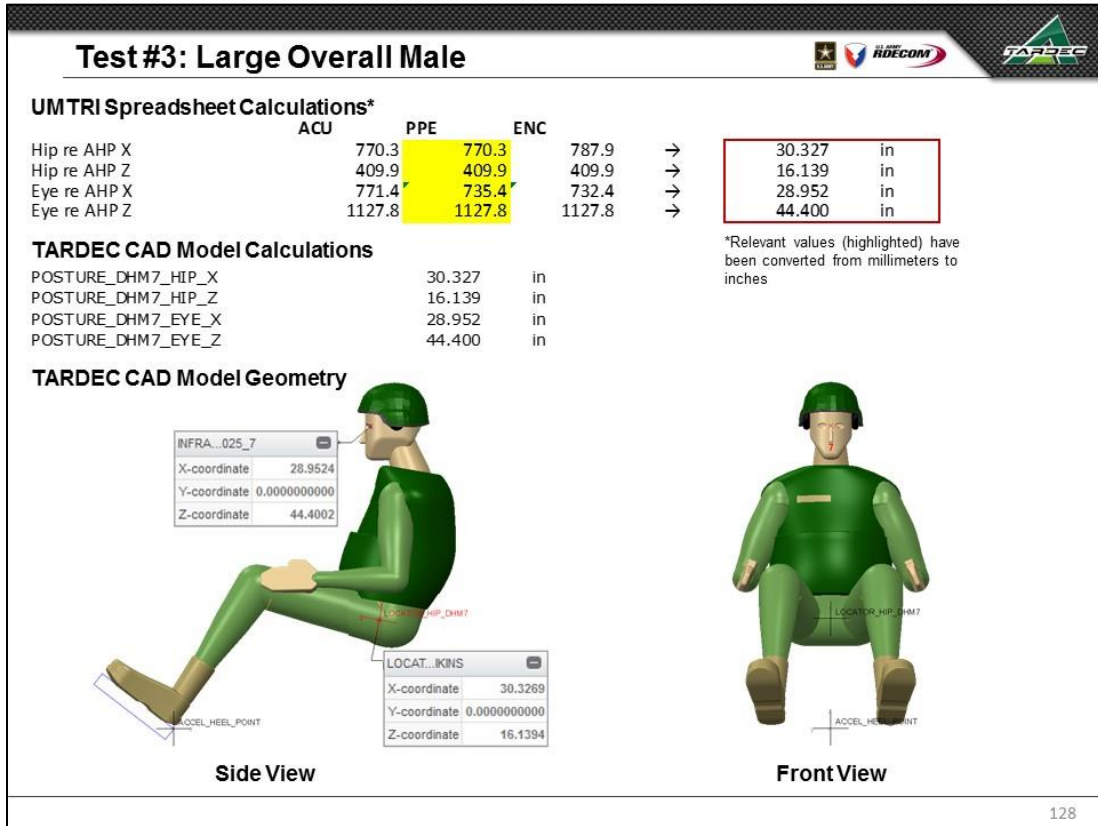

10.7.4 TEST #4 – VARY SWP IN FORE-AFT (X) DIRECTION

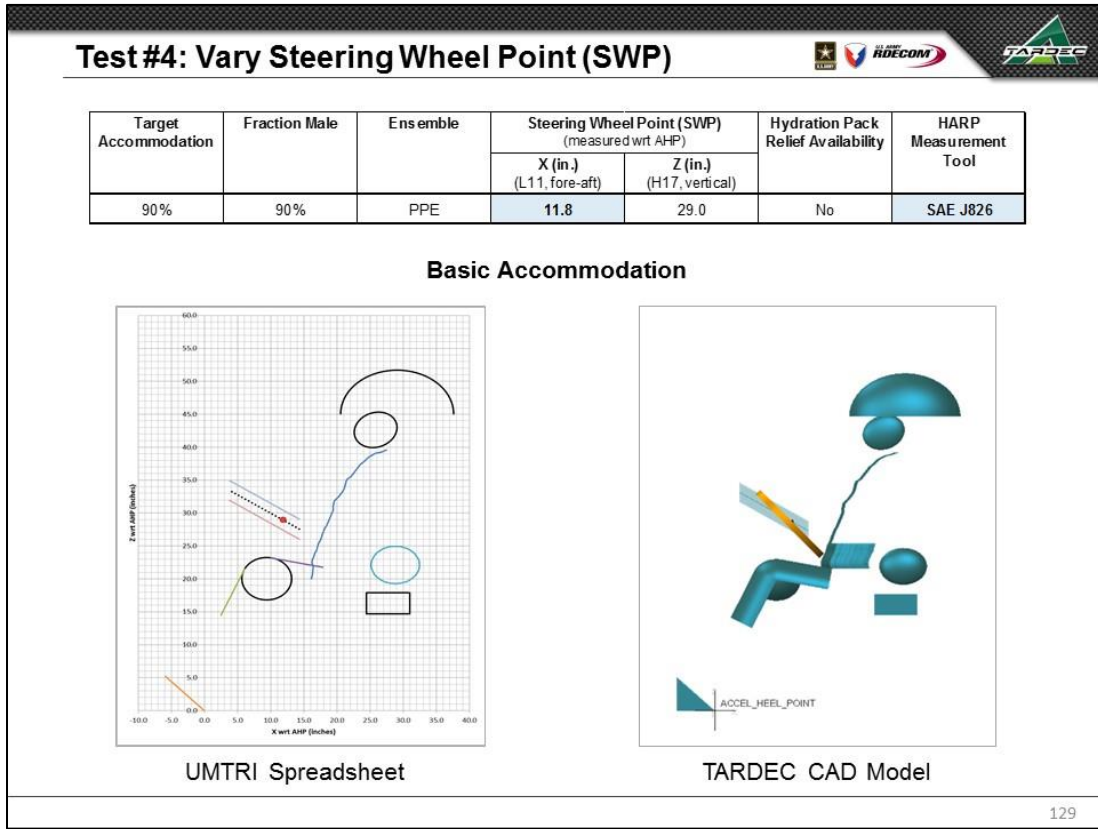

Test #4: Numerical Results, Accommodation

Surrogate Steering Wheel			
	UMTRI Value	TARDEC Value	Difference
STEERING_WHEEL_X	11.800 in	11.800 in	0.000 in
STEERING_WHEEL_Z	29.000 in	29.000 in	0.000 in
Steering Wheel Preference Line			
	UMTRI Value	TARDEC Value	Difference
STRG_WHL_FWD_X	14.297 in	14.297 in	0.000 in
STRG_WHL_FWD_Z	27.559 in	27.559 in	0.000 in
STRG_WHL_RWD_X	3.733 in	3.733 in	0.000 in
STRG_WHL_RWD_Z	33.465 in	33.465 in	0.000 in
Steering Wheel Preference Zone			
	UMTRI Value	TARDEC Value	Difference
STRG_WHL_ZONE_Z	1.516 in	1.516 in	0.001 in
STRG_WHL_ZONE_Y	N/A	1.000 in	N/A
Accelerator Plane Angle (APA)			
	UMTRI Value	TARDEC Value	Difference
ACCEL_PEDAL_PLANE_ANG	41.438 deg	41.438 deg	0.000 deg
Origin (X)	0.000 in	0.000 in	0.000 in
Origin (Z)	0.000 in	0.000 in	0.000 in
BOFRP (X)	-5.903 in	-5.903 in	0.000 in
BOFRP (Z)	5.211 in	5.211 in	0.000 in
Seat Track Travel Range			
	UMTRI Value	TARDEC Value	Difference
SEAT_POSITION_CTR_OF_TRAVEL_X	27.690 in	27.691 in	0.001 in
SEAT_POSITION_CTR_OF_TRAVEL_Z	16.279 in	16.279 in	0.000 in
SEAT_POSITION_FORE_AFT_TRAVEL	6.539 in	6.535 in	0.001 in
SEAT_POSITION_VERTICAL_TRAVEL	3.223 in	3.223 in	0.001 in
Seat Back Angle			
	UMTRI Value	TARDEC Value	Difference
SEAT_BACK_ANGLE_LOWER_QUANTILE	16.148 deg	16.145 deg	0.004 deg
SEAT_BACK_ANGLE_UPPER_QUANTILE	26.346 deg	26.350 deg	0.004 deg
Eyellipse			
	UMTRI Value	TARDEC Value	Difference
EYELLIPSE_CENTROID_X	25.812 in	25.812 in	0.000 in
EYELLIPSE_CENTROID_Y (+/-)	1.280 in	1.280 in	0.000 in
EYELLIPSE_CENTROID_Z	42.637 in	42.637 in	0.000 in
EYELLIPSE_ANGLE_REL_X	18.600 deg	18.600 deg	0.000 deg
EYELLIPSE_X_AXIS_LENGTH	6.570 in	6.573 in	0.003 in
EYELLIPSE_Y_AXIS_LENGTH	1.917 in	1.918 in	0.001 in
EYELLIPSE_Z_AXIS_LENGTH	5.236 in	5.240 in	0.004 in

Helmet Boundary			
	UMTRI Value	TARDEC Value	Difference
HELMET_CONTOUR_CBTRD_X	29.056 in	29.056 in	0.000 in
HELMET_CONTOUR_CBTRD_Y (+/-)	2.185 in	2.185 in	0.000 in
HELMET_CONTOUR_CBTRD_Z	45.054 in	45.055 in	0.000 in
HELMET_CONTOUR_X_AXIS_LENGTH	17.045 in	17.048 in	0.003 in
HELMET_CONTOUR_Y_AXIS_LENGTH	9.515 in	9.517 in	0.001 in
HELMET_CONTOUR_Z_AXIS_LENGTH	13.292 in	13.296 in	0.004 in
Knee Boundary			
	UMTRI Value	TARDEC Value	Difference
KNEE_CONTOUR_WEIGHTED_CENT_X	9.382 in	9.382 in	0.000 in
KNEE_CONTOUR_WEIGHTED_CENT_Y (+/-)	7.458 in	7.458 in	0.000 in
KNEE_CONTOUR_WEIGHTED_CENT_Z	20.033 in	20.033 in	0.000 in
KNEE_CONTOUR_X_AXIS_LENGTH	7.511 in	7.513 in	0.002 in
KNEE_CONTOUR_Y_AXIS_LENGTH	8.671 in	8.673 in	0.001 in
KNEE_CONTOUR_Z_AXIS_LENGTH	6.452 in	6.452 in	0.000 in
KNEE_SHOUL_ANGLE	26.682 deg	26.682 deg	0.000 deg
KNEE_THIGH_ANGLE	10.322 deg	10.322 deg	0.000 deg
Torso Boundary			
	UMTRI Value	TARDEC Value	Difference
TORSO_WEIGHTED_REF_PT_PFE_X	21.559 in	21.558 in	0.001 in
TORSO_WEIGHTED_REF_PT_PFE_Z	33.583 in	33.583 in	0.000 in
Elbow Boundary			
	UMTRI Value	TARDEC Value	Difference
ELBOW_WEIGHTED_CBNT_X	28.790 in	28.790 in	0.000 in
ELBOW_WEIGHTED_CBNT_Y (+/-)	12.353 in	12.353 in	0.000 in
ELBOW_WEIGHTED_CBNT_Z	22.123 in	22.123 in	0.000 in
ELBOW_X_AXIS_LENGTH	7.303 in	7.305 in	0.002 in
ELBOW_Y_AXIS_LENGTH	3.424 in	3.425 in	0.001 in
ELBOW_Z_AXIS_LENGTH	5.665 in	5.668 in	0.003 in

TARDEC CAD values to agree with UMTRI spreadsheet values within
 ±0.100 inches
 ±0.100 degrees

Largest Observed Differences:
 0.004 inches
 0.004 degrees

Values in agreement

130

Test #4: Surrogate Steering Wheel

UMTRI Spreadsheet Calculations

	L11	H17
	(in)	(in)
Steering Wheel Point (SWP)	11.800	29.000

TARDEC CAD Model Calculations

STEERING_WHEEL_X	11.800	in
STEERING_WHEEL_Z	29.000	in

TARDEC CAD Model Geometry

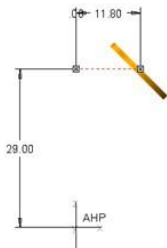

Side View

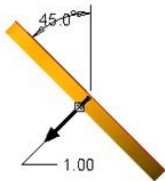

Side View

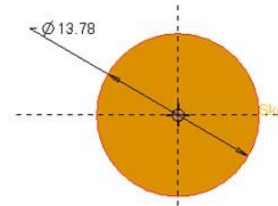

Normal to Steering Wheel

Steering Wheel Geometry

131

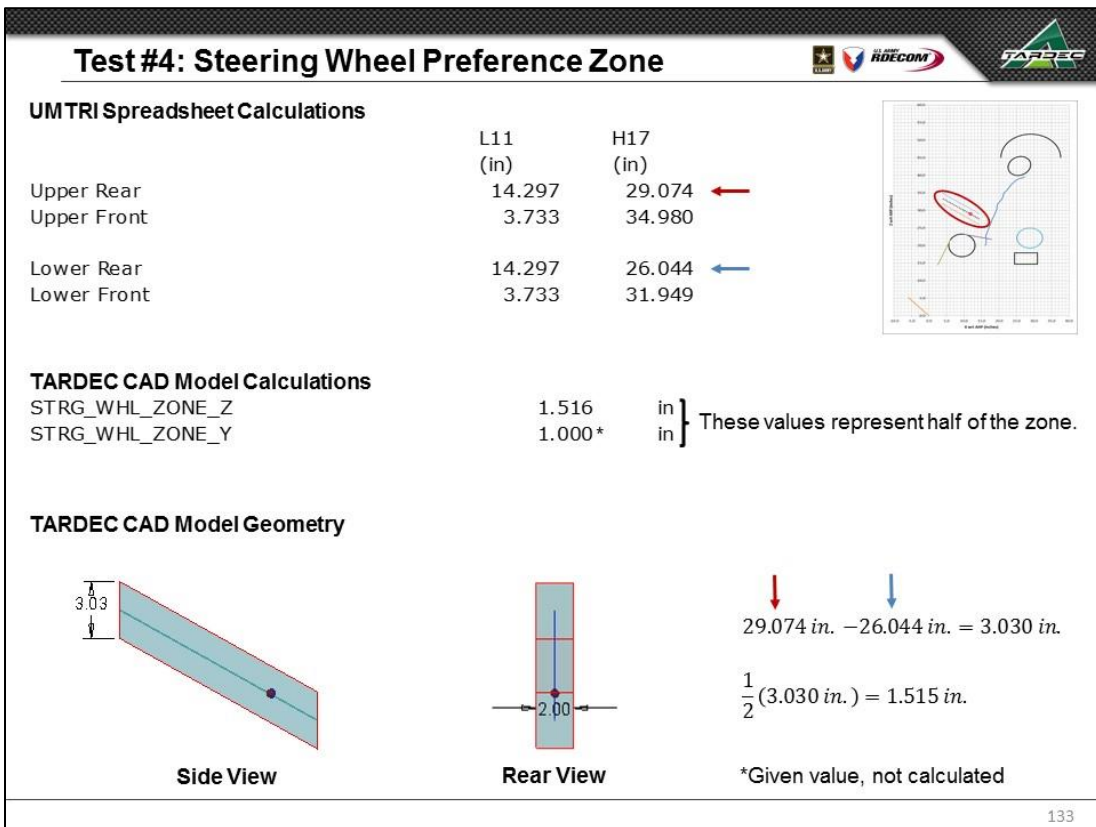
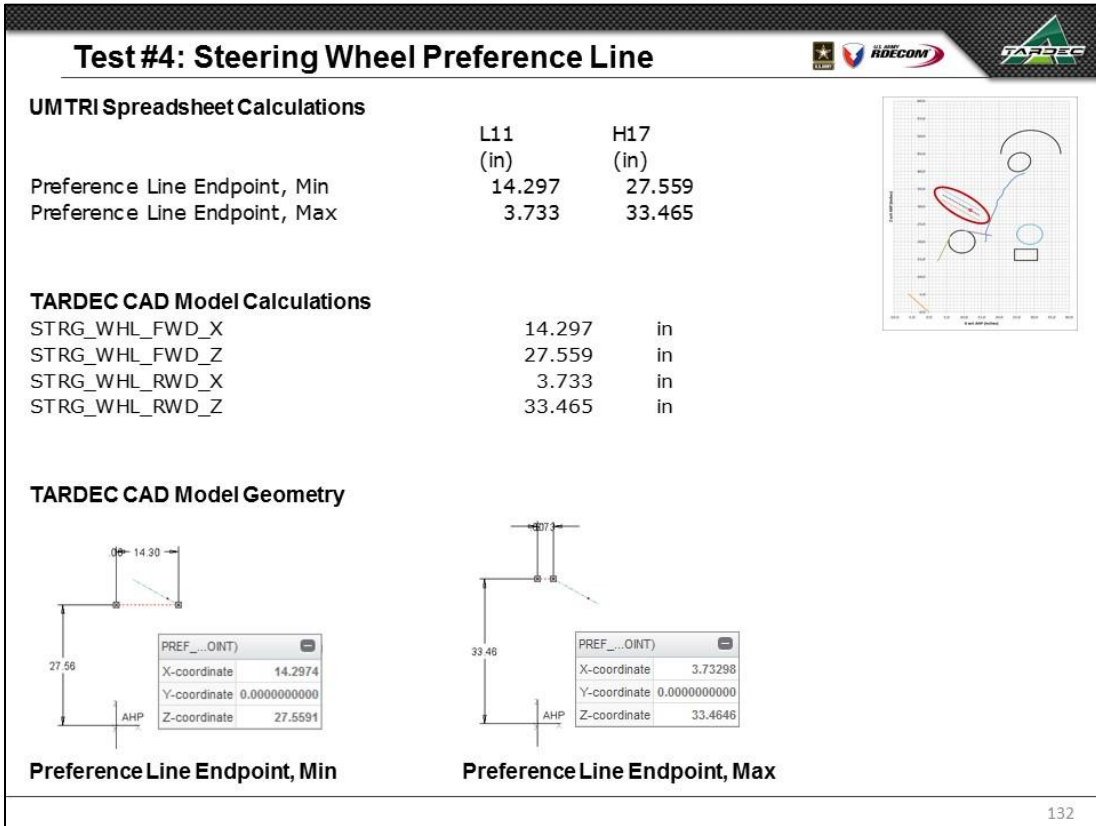

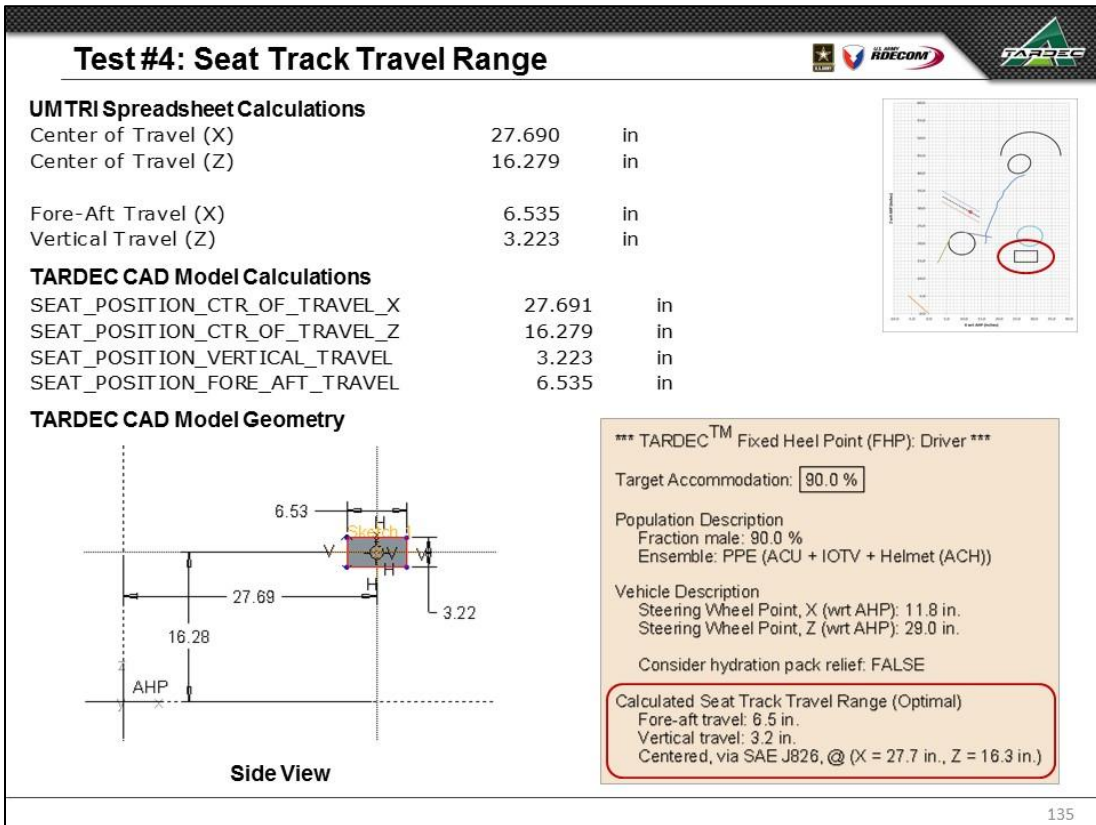
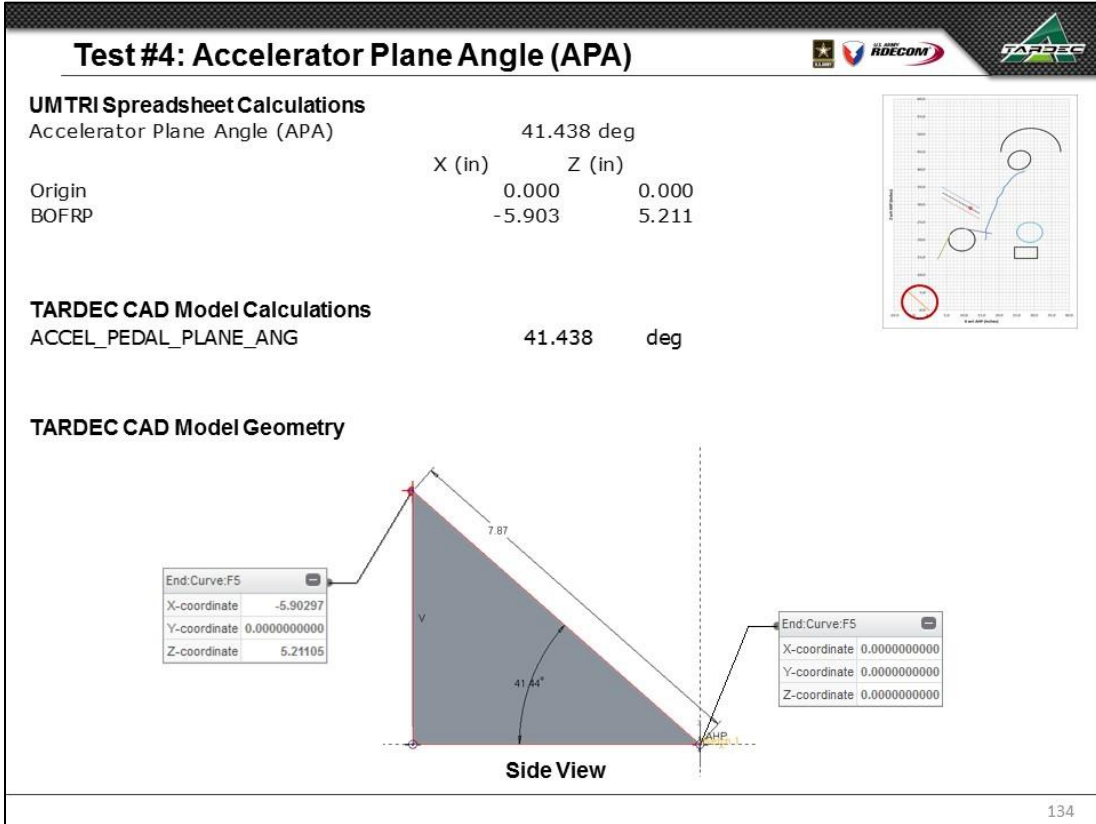

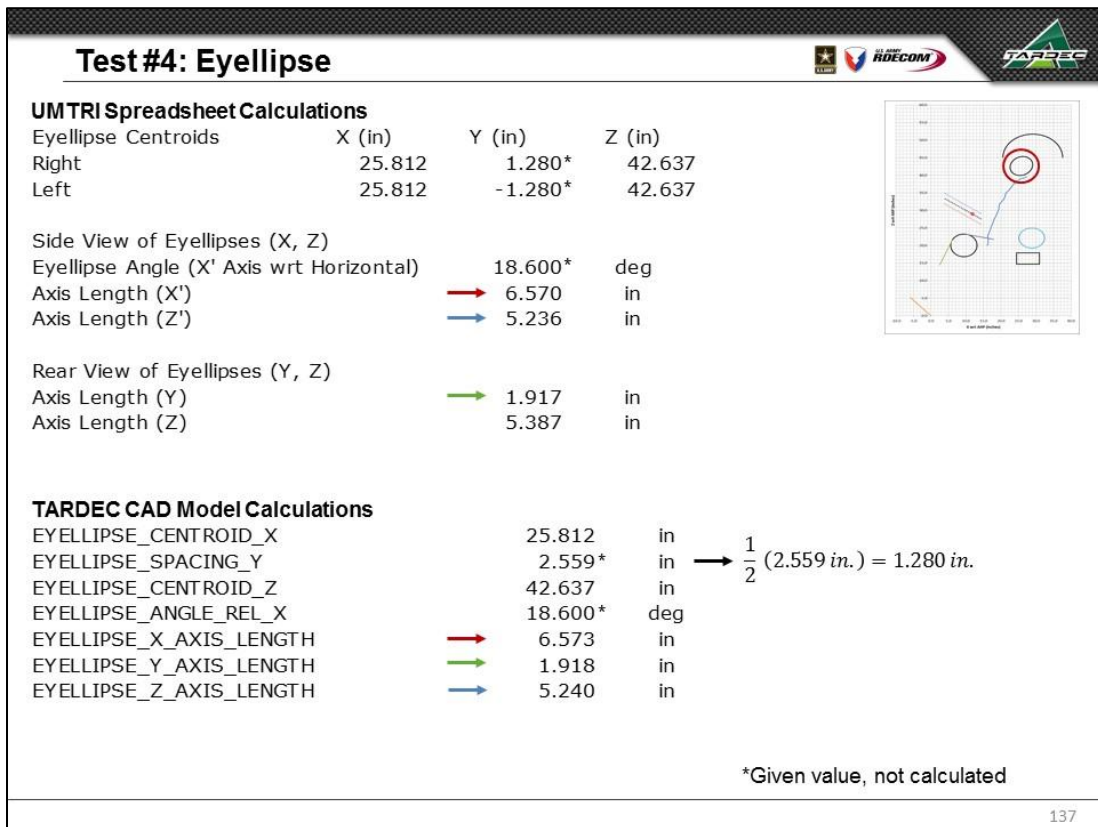
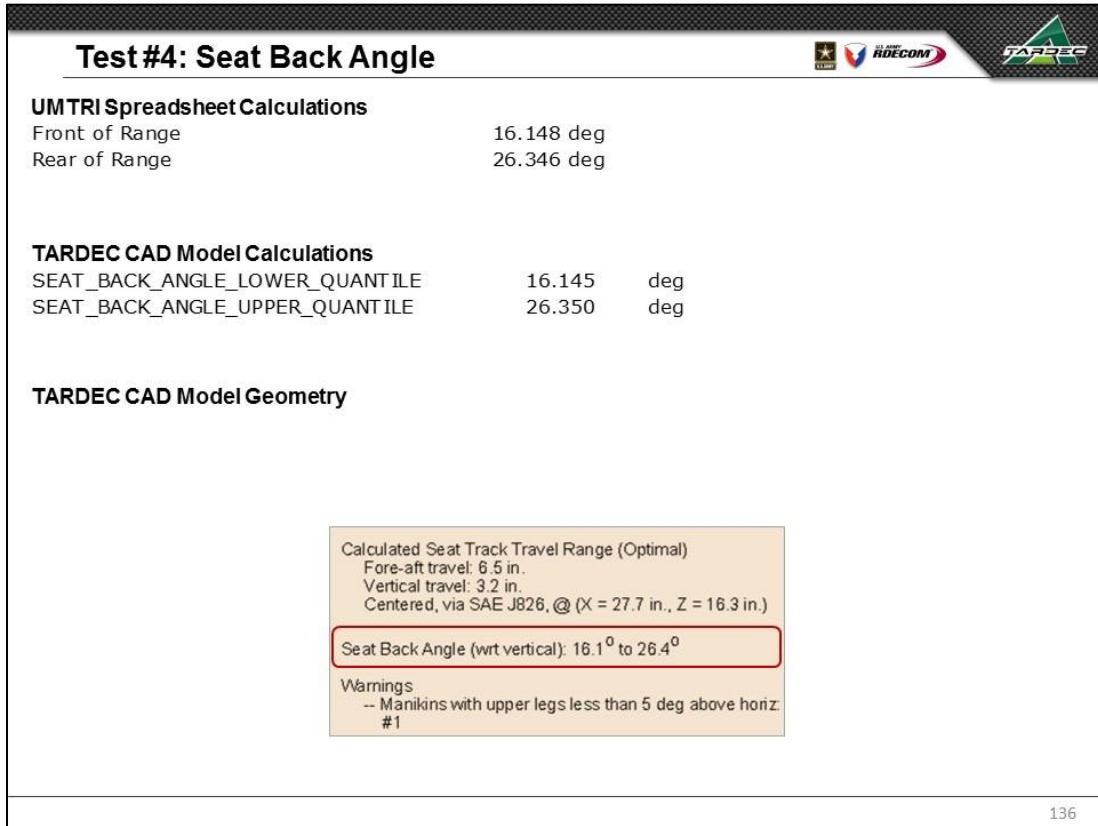

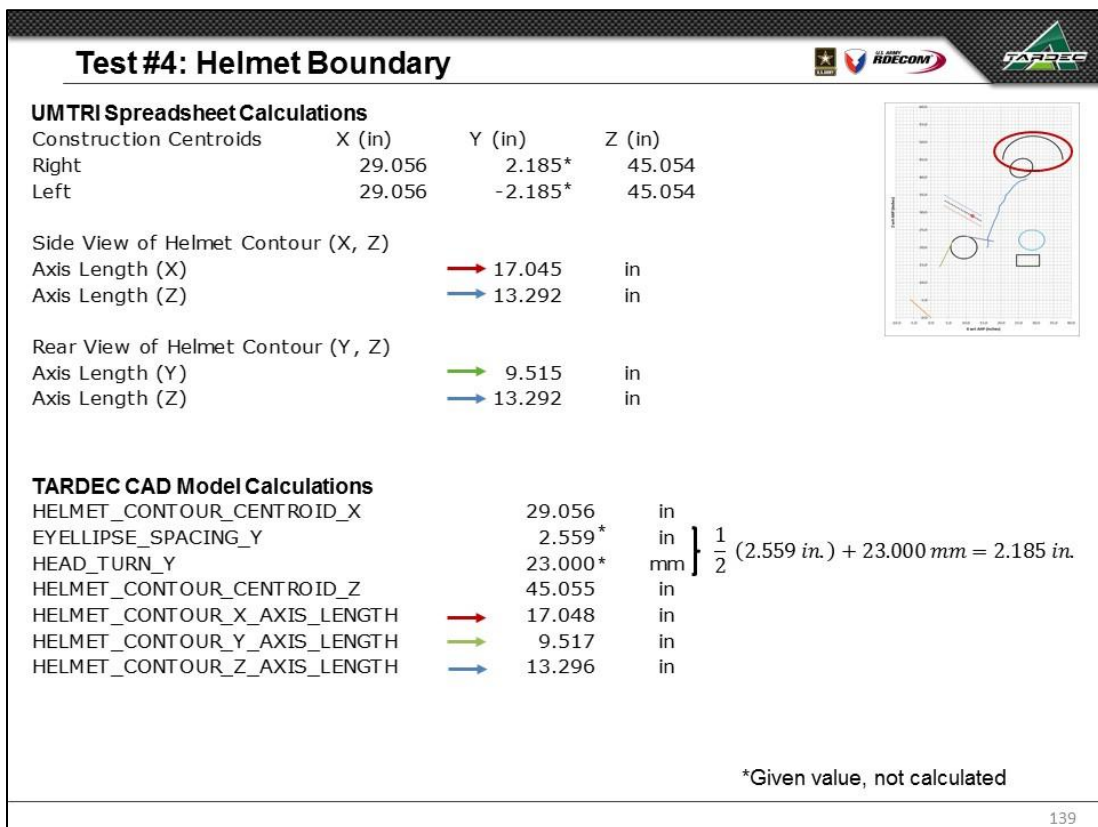
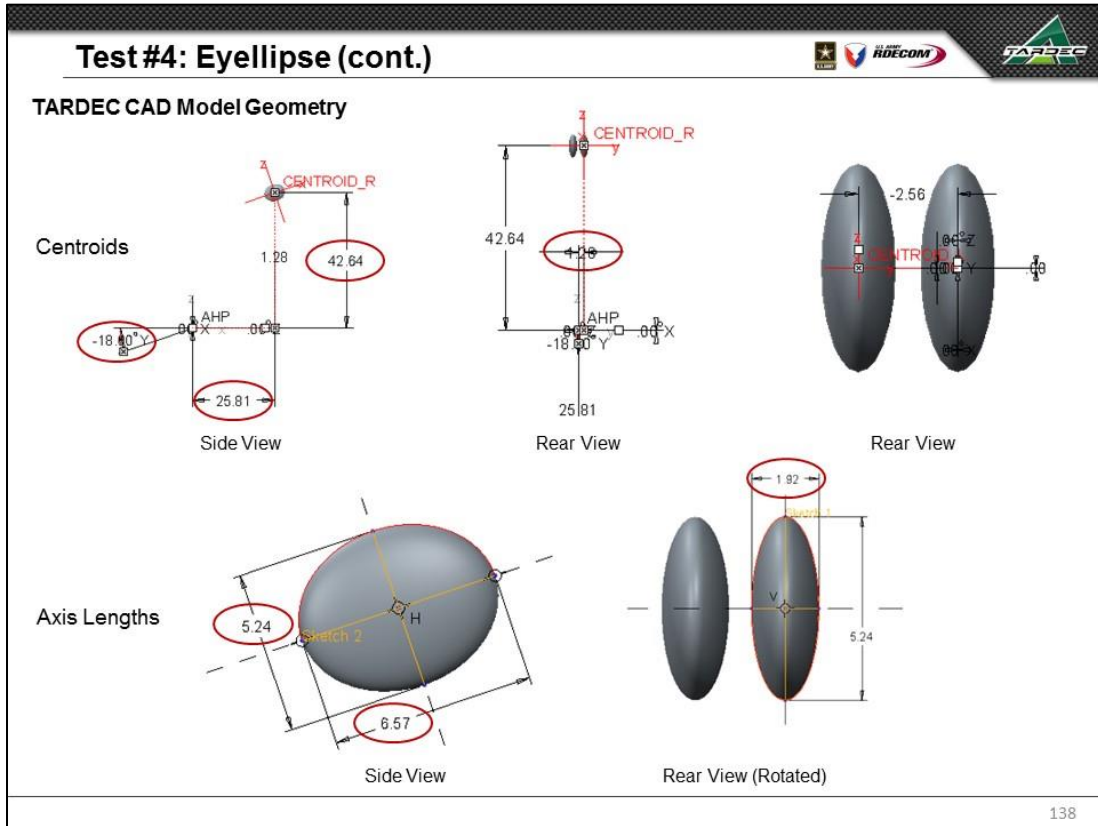

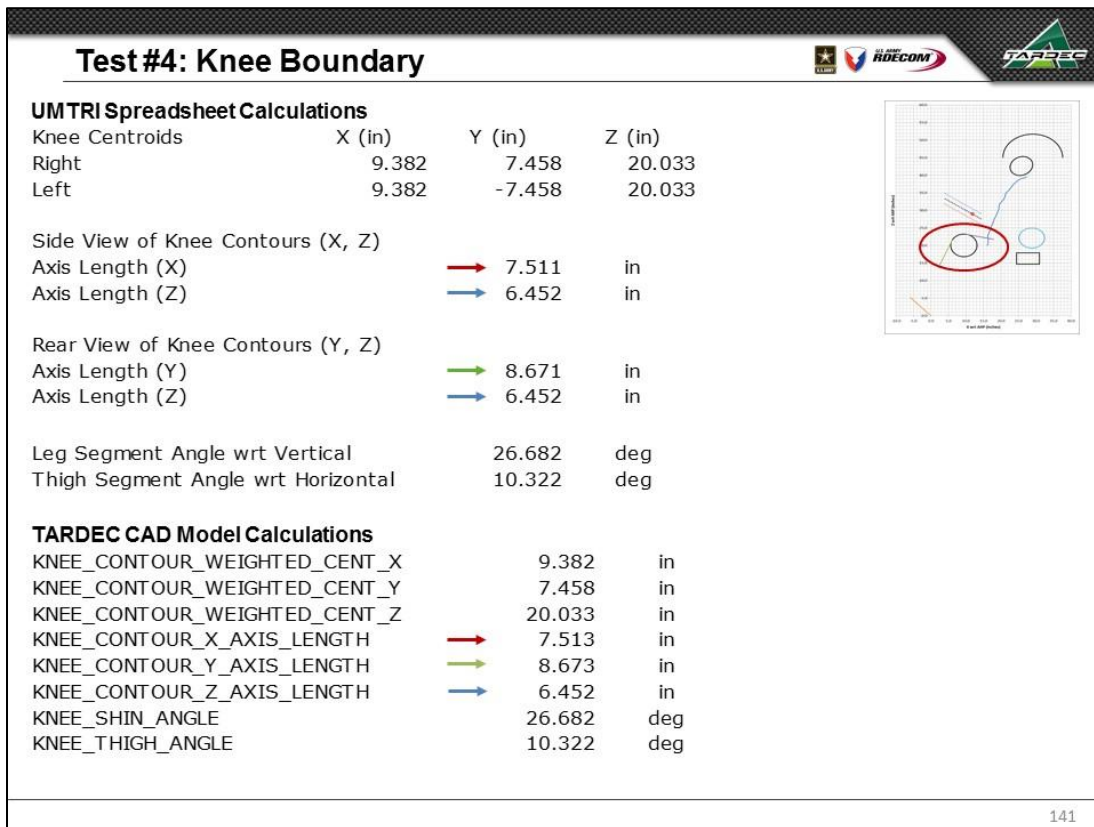
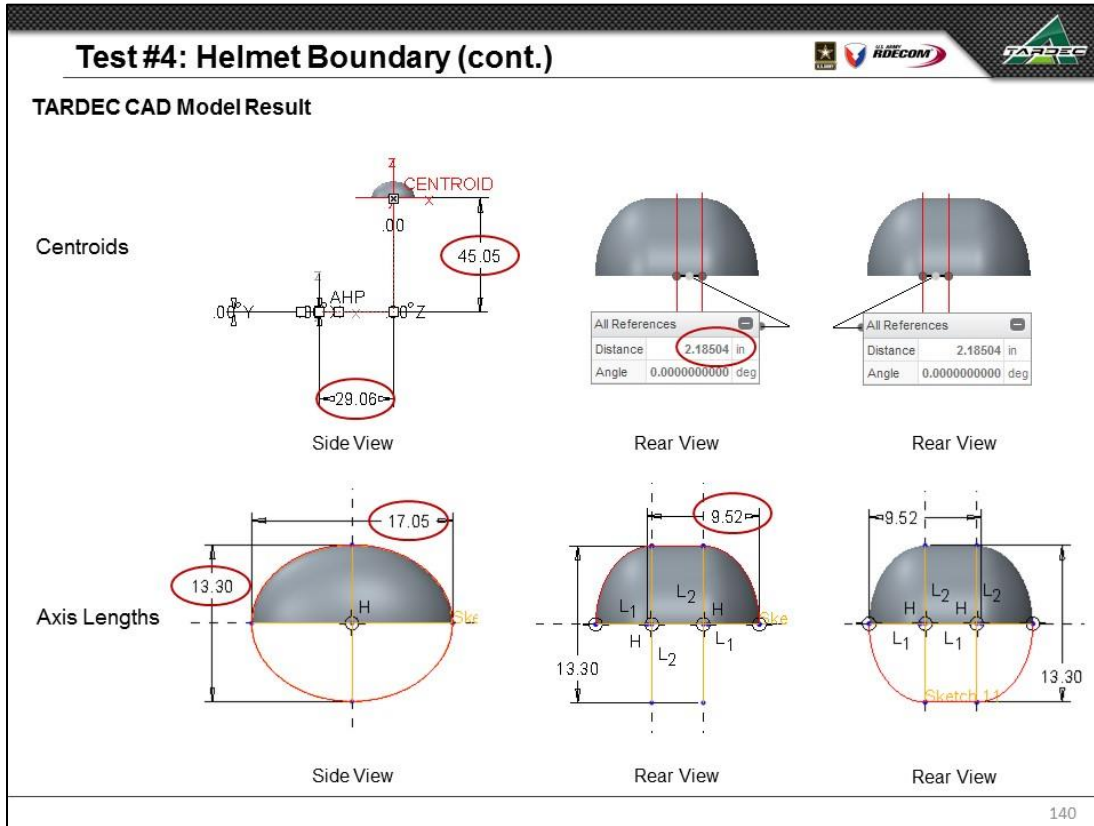

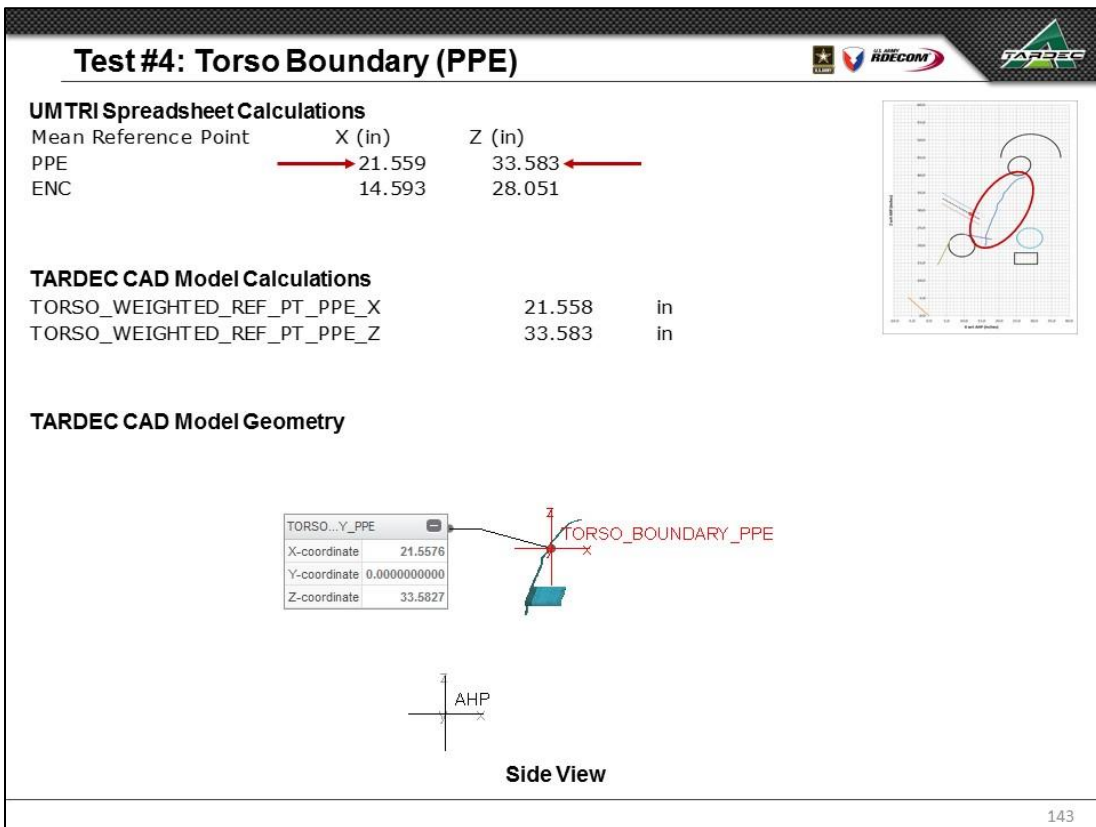
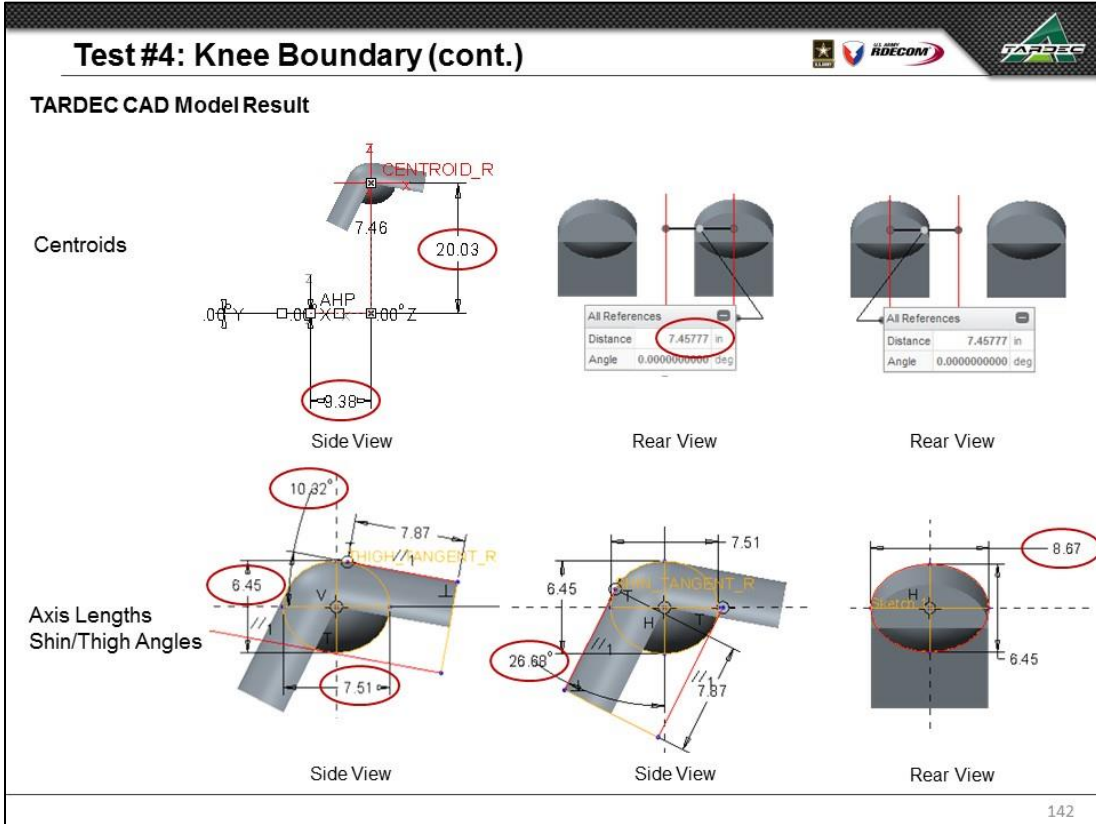

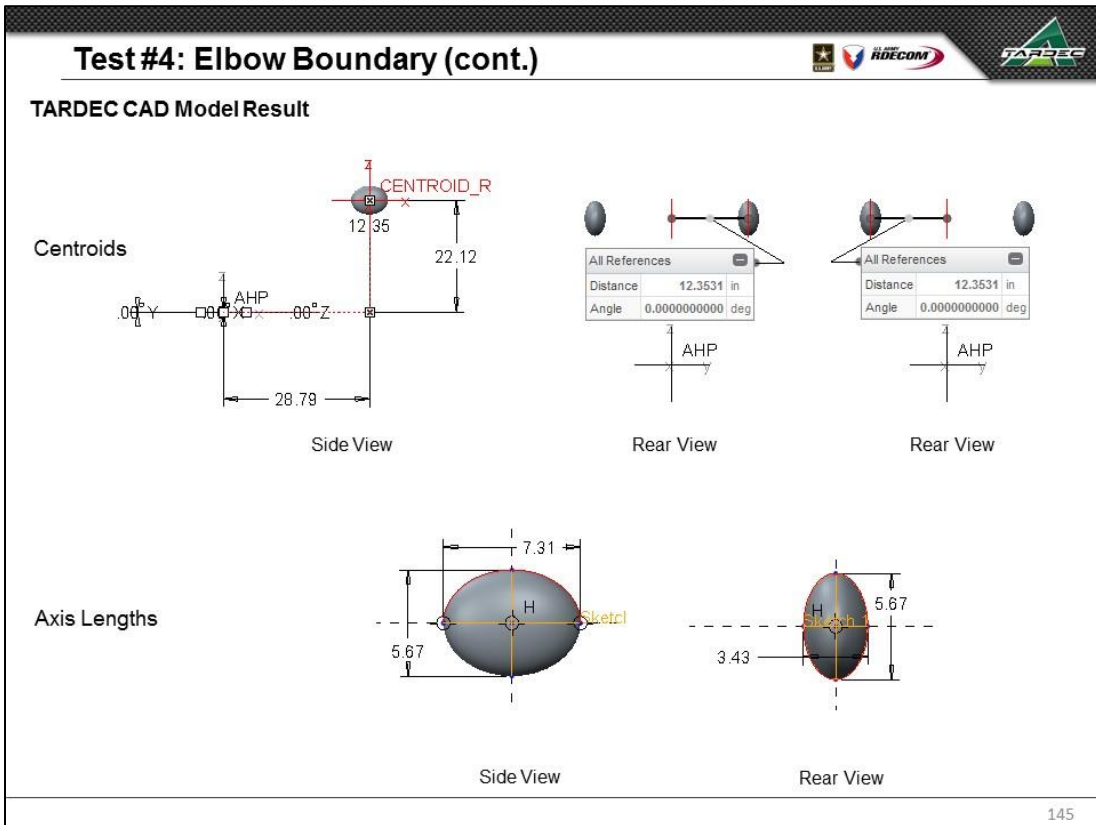
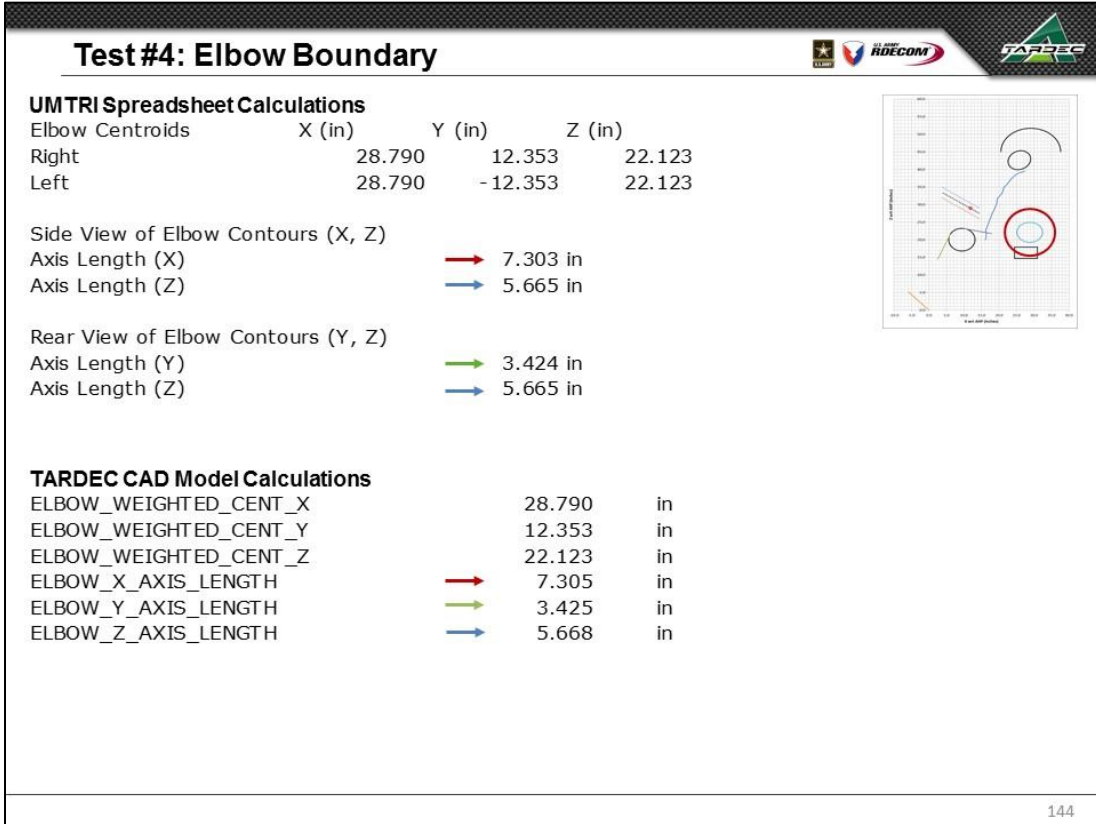

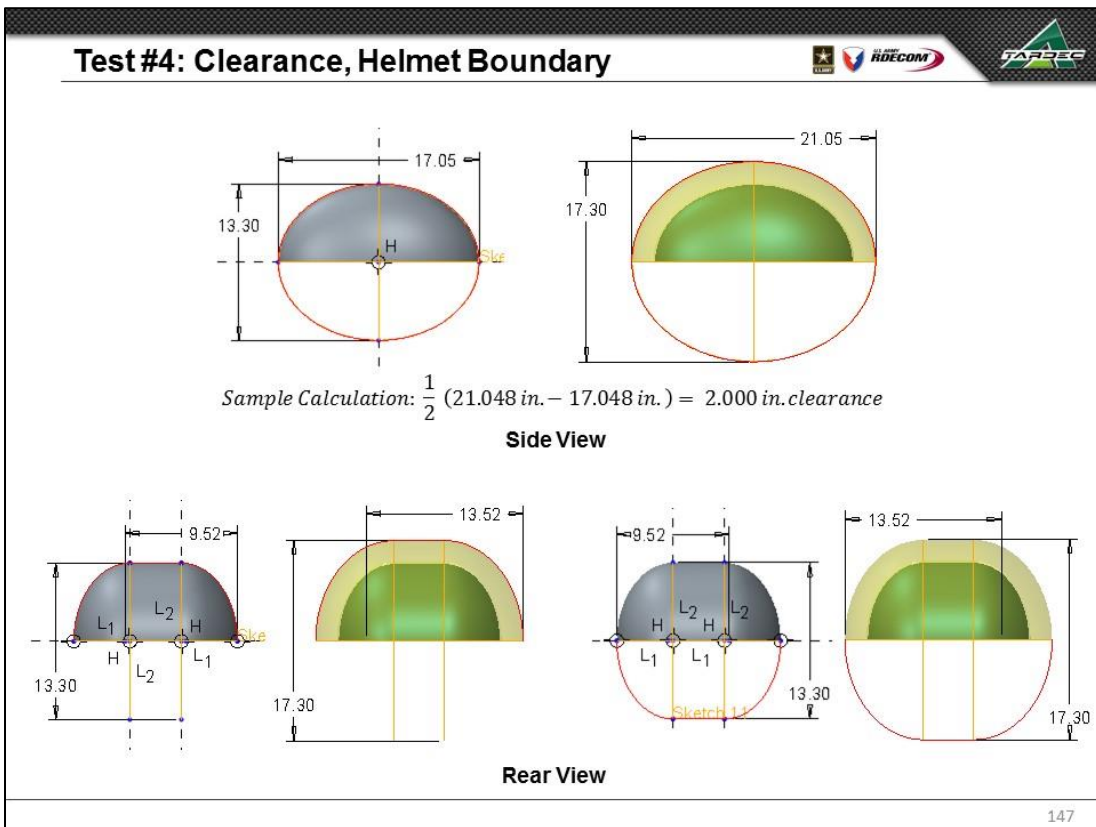
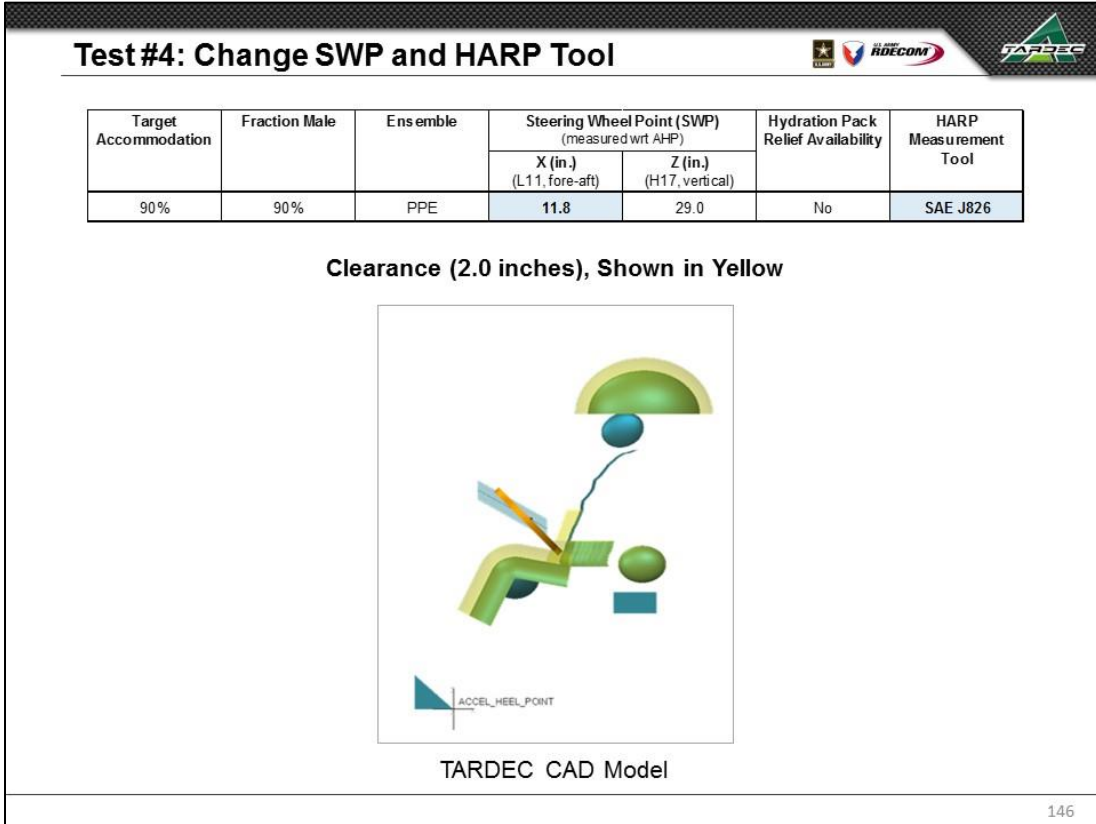

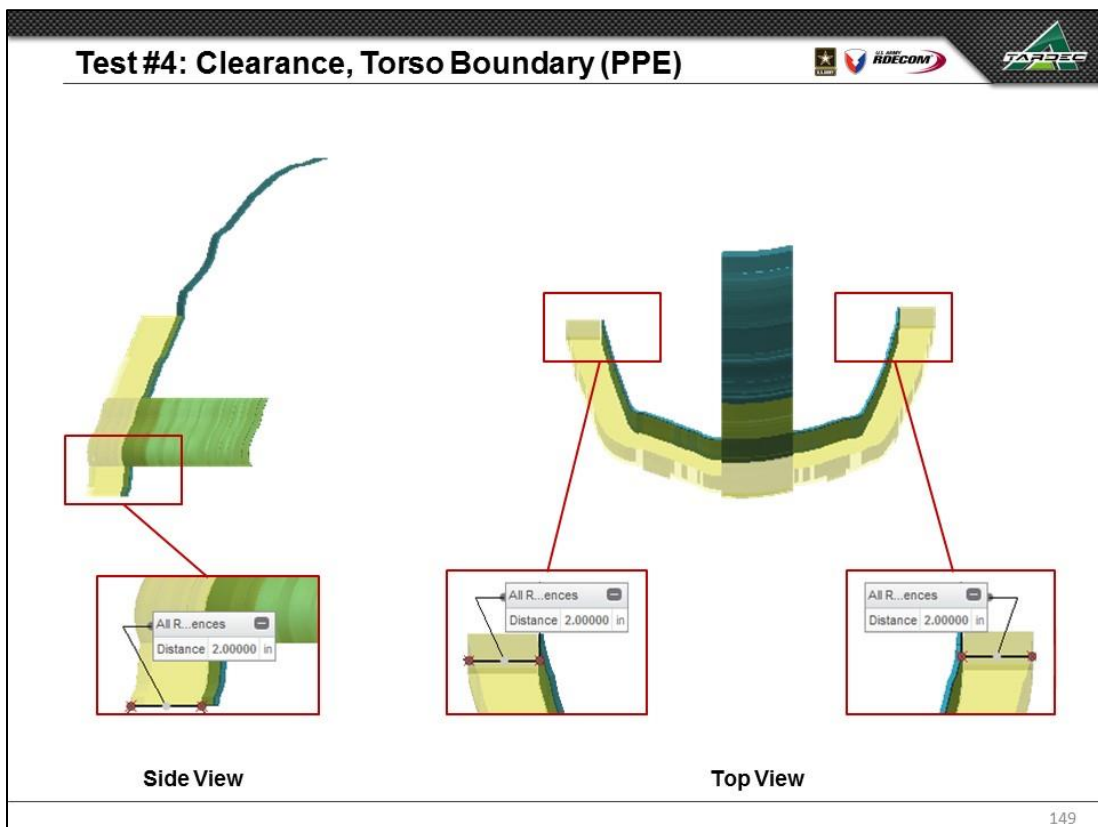
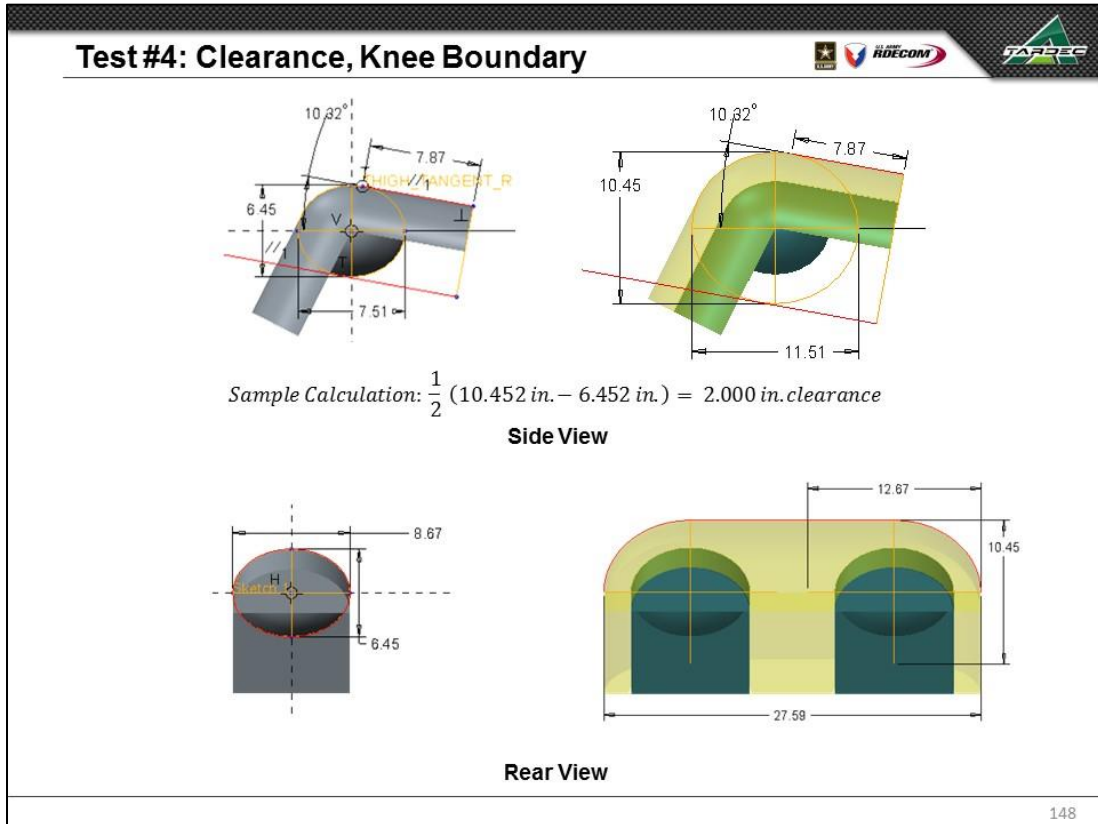

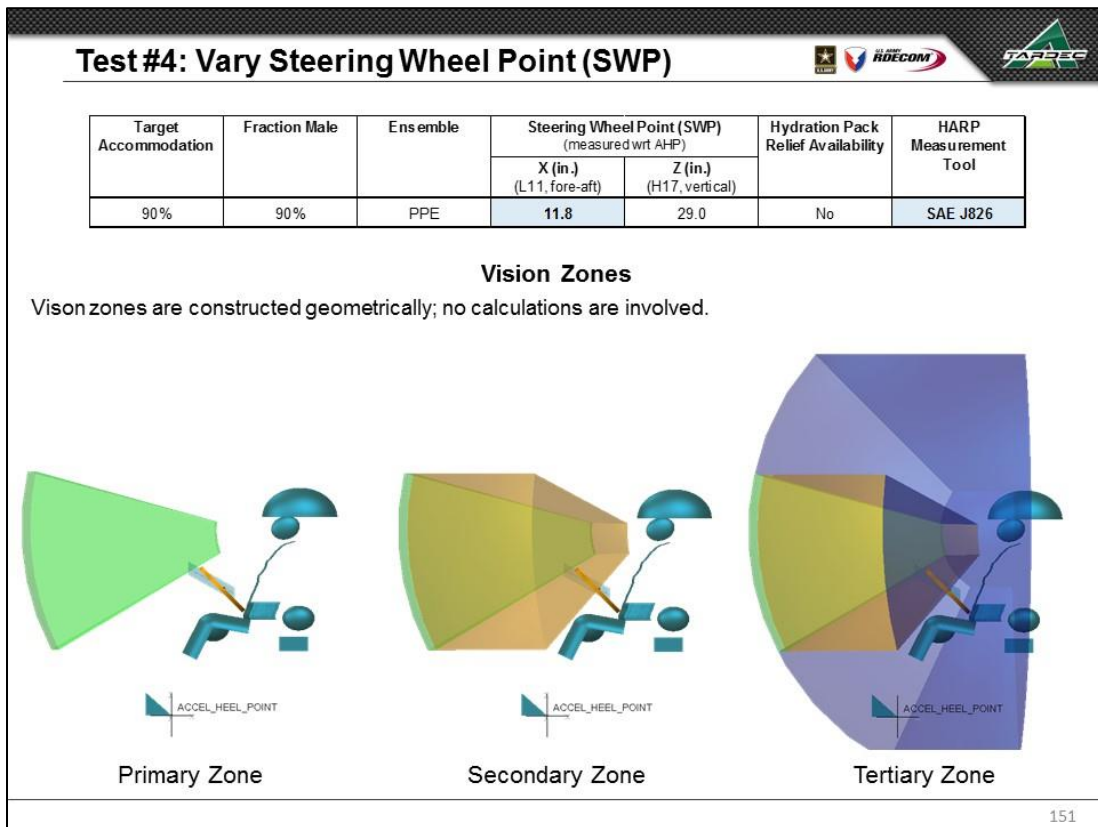
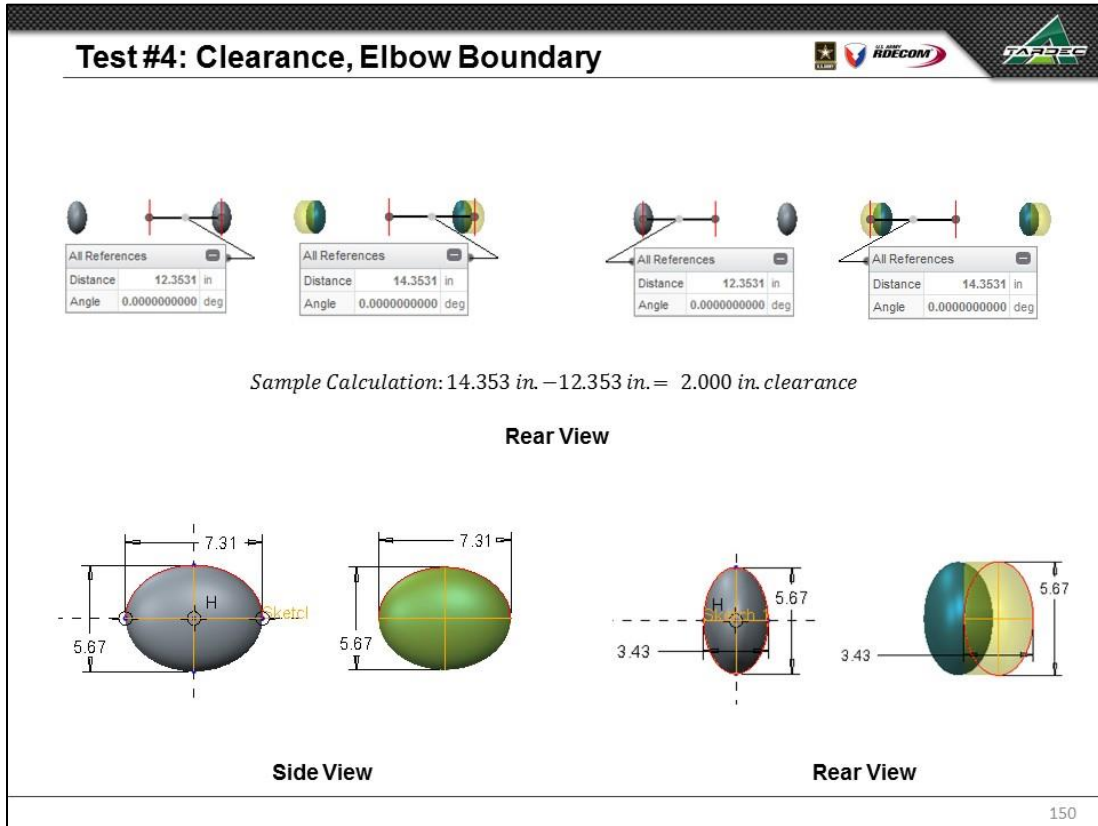

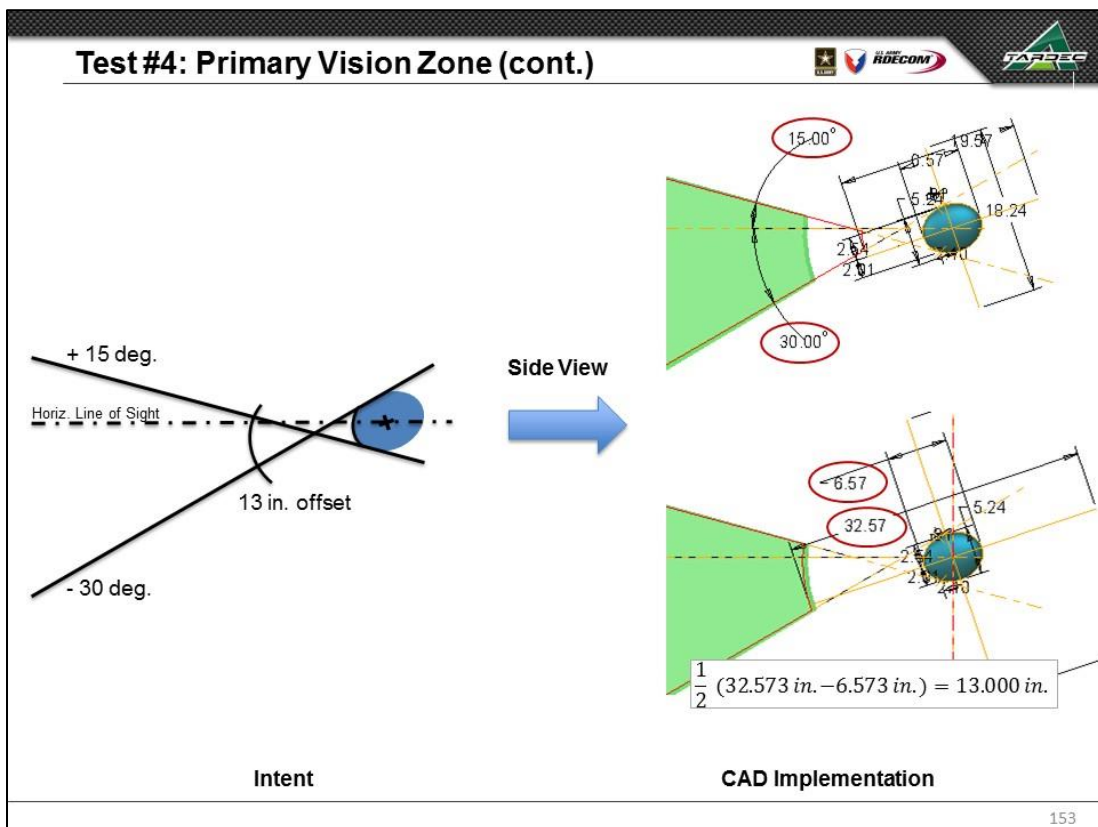
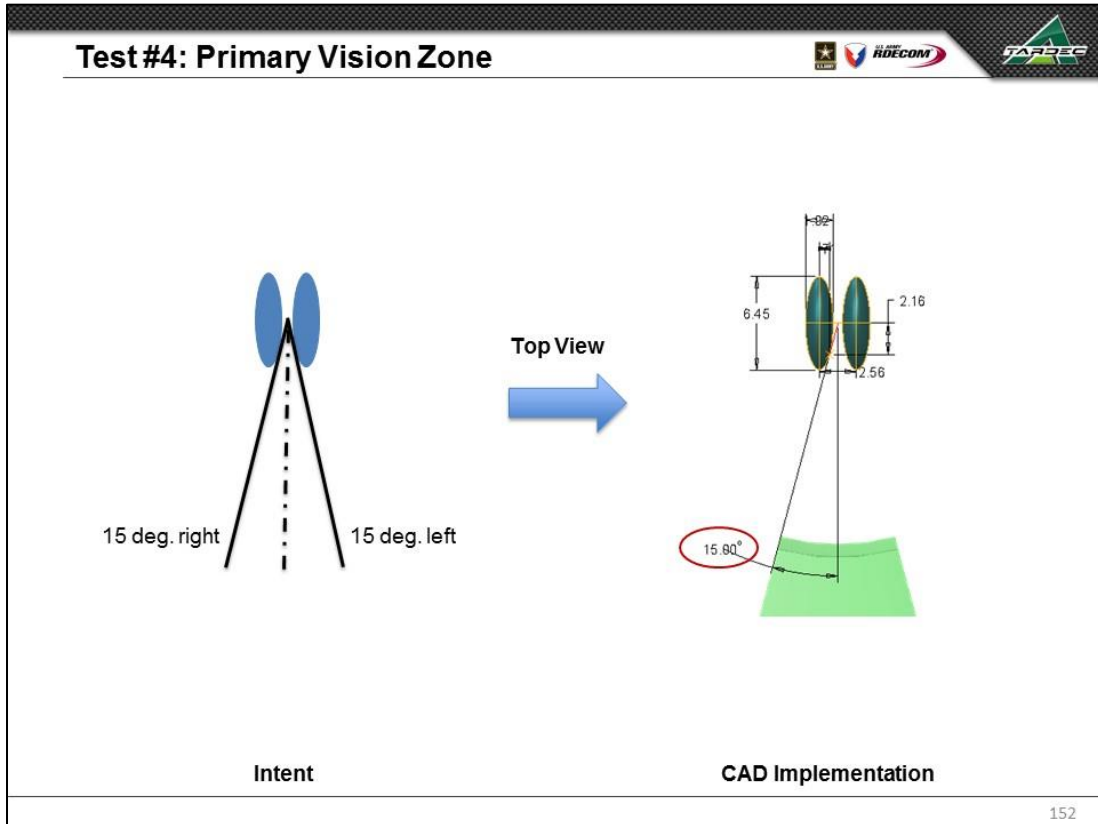

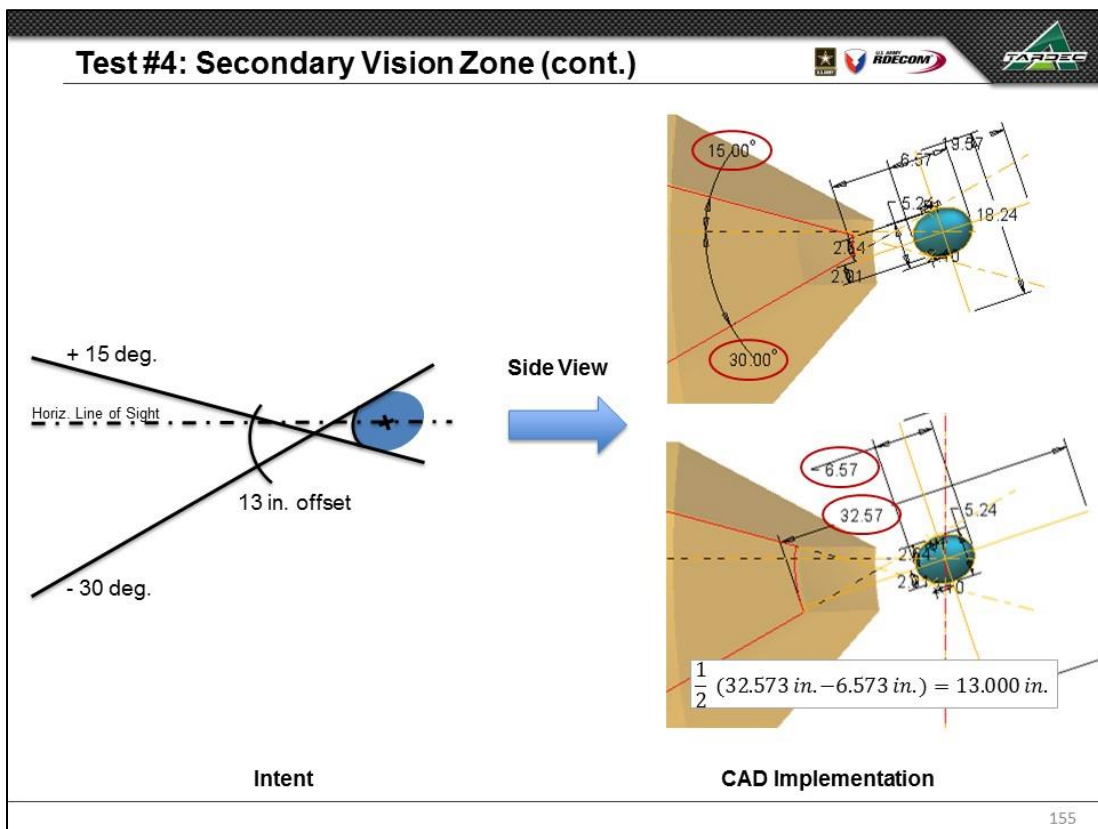
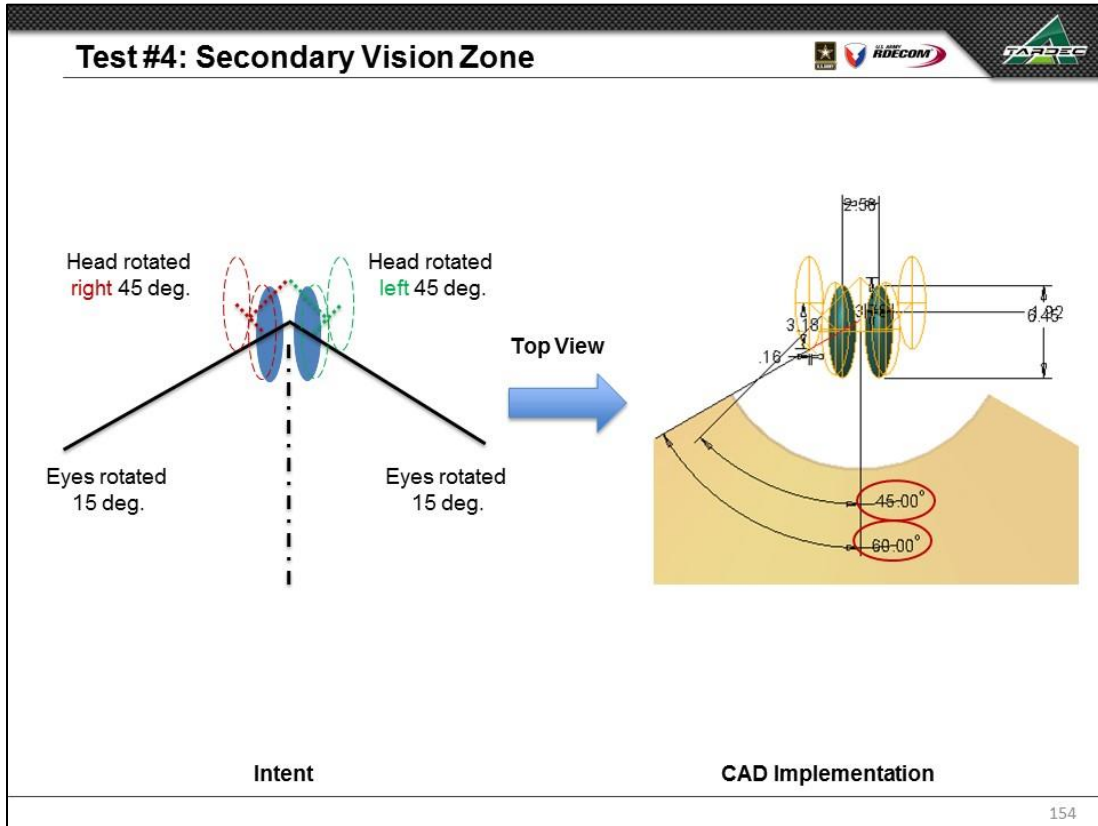

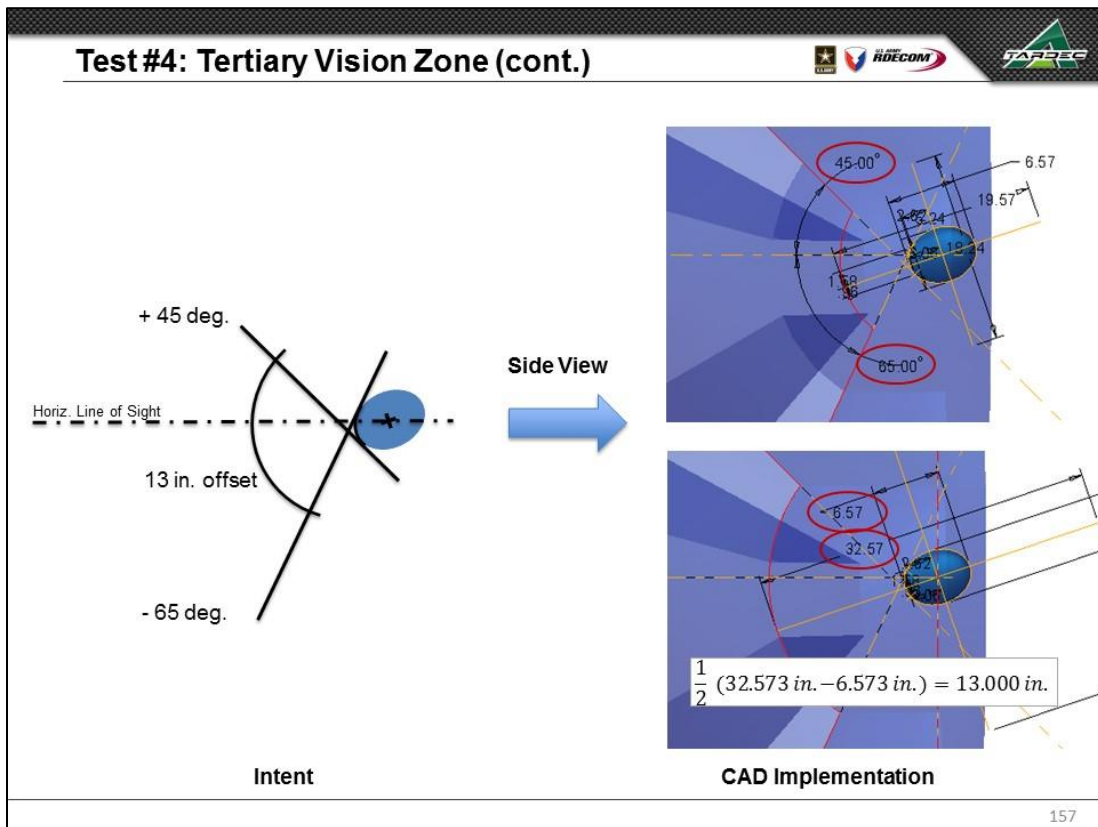
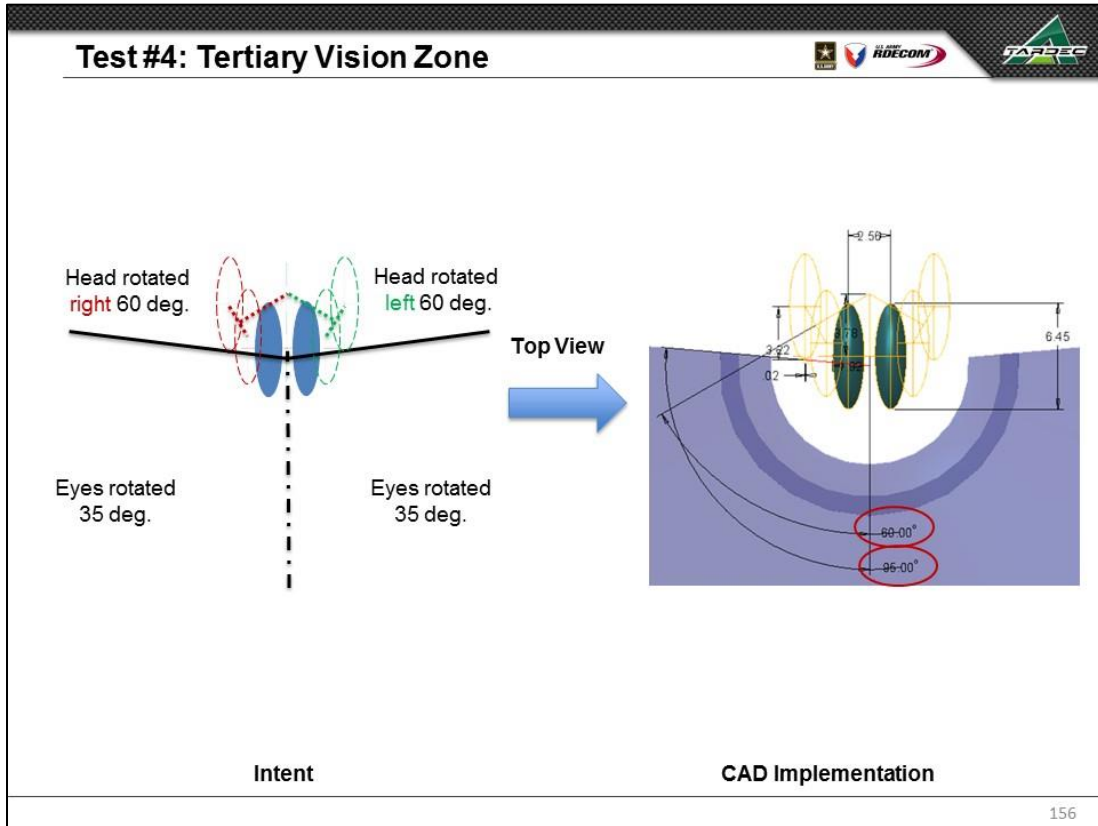



Test #4: Vary Steering Wheel Point (SWP)



Target Accommodation	Fraction Male	Ensemble	Steering Wheel Point (SWP) (measured wrt AHP)		Hydration Pack Relief Availability	HARP Measurement Tool
			X (in.) (L11, fore-aft)	Z (in.) (H17, vertical)		
90%	90%	PPE	11.8	29.0	No	SAE J826

Boundary Manikin Posture and Position



TARDEC CAD Model

158

Test #4: Numerical Results, Manikin Positioning



Small Overall Female			
	UMTRI Value	TARDEC Value	Difference
POSTURE_DHM1_HIP_X	22.881 in	22.881 in	0.000 in
POSTURE_DHM1_HIP_Z	15.992 in	15.992 in	0.000 in
POSTURE_DHM1_EYE_X	24.036 in	24.036 in	0.000 in
POSTURE_DHM1_EYE_Z	38.171 in	38.171 in	0.000 in
Small Overall Male			
	UMTRI Value	TARDEC Value	Difference
POSTURE_DHM2_HIP_X	25.003 in	25.003 in	0.000 in
POSTURE_DHM2_HIP_Z	16.102 in	16.102 in	0.000 in
POSTURE_DHM2_EYE_X	25.286 in	25.286 in	0.000 in
POSTURE_DHM2_EYE_Z	39.938 in	39.938 in	0.000 in
Average Size Male			
	UMTRI Value	TARDEC Value	Difference
POSTURE_DHM3_HIP_X	27.199 in	27.199 in	0.000 in
POSTURE_DHM3_HIP_Z	16.101 in	16.101 in	0.000 in
POSTURE_DHM3_EYE_X	26.695 in	26.695 in	0.000 in
POSTURE_DHM3_EYE_Z	42.162 in	42.162 in	0.000 in
Widest Shoulders Male			
	UMTRI Value	TARDEC Value	Difference
POSTURE_DHM4_HIP_X	28.207 in	28.207 in	0.000 in
POSTURE_DHM4_HIP_Z	16.090 in	16.090 in	0.000 in
POSTURE_DHM4_EYE_X	27.351 in	27.351 in	0.000 in
POSTURE_DHM4_EYE_Z	43.440 in	43.440 in	0.000 in
Longest Torso Male			
	UMTRI Value	TARDEC Value	Difference
POSTURE_DHM5_HIP_X	27.451 in	27.450 in	0.000 in
POSTURE_DHM5_HIP_Z	16.084 in	16.084 in	0.000 in
POSTURE_DHM5_EYE_X	26.861 in	26.861 in	0.000 in
POSTURE_DHM5_EYE_Z	44.441 in	44.441 in	0.000 in
Longest Legs Male			
	UMTRI Value	TARDEC Value	Difference
POSTURE_DHM6_HIP_X	29.723 in	29.723 in	0.000 in
POSTURE_DHM6_HIP_Z	16.155 in	16.155 in	0.000 in
POSTURE_DHM6_EYE_X	28.271 in	28.272 in	0.000 in
POSTURE_DHM6_EYE_Z	42.661 in	42.661 in	0.000 in
Large Overall Male			
	UMTRI Value	TARDEC Value	Difference
POSTURE_DHM7_HIP_X	29.548 in	29.548 in	0.000 in
POSTURE_DHM7_HIP_Z	16.252 in	16.252 in	0.000 in
POSTURE_DHM7_EYE_X	28.048 in	28.048 in	0.000 in
POSTURE_DHM7_EYE_Z	44.400 in	44.400 in	0.000 in

TARDEC CAD values to agree with UMTRI spreadsheet values within
 ±0.100 inches
 ±0.100 degrees

Largest Observed Differences:
 0.000 inches

Values in agreement

159

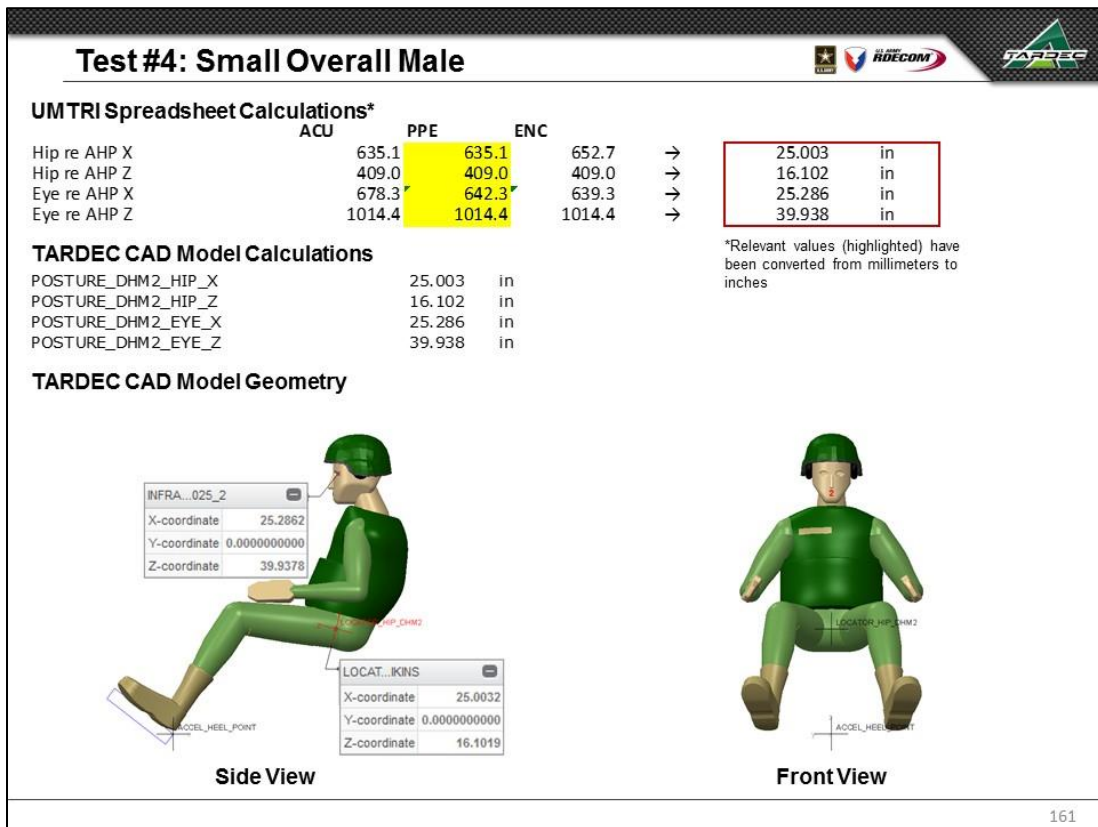
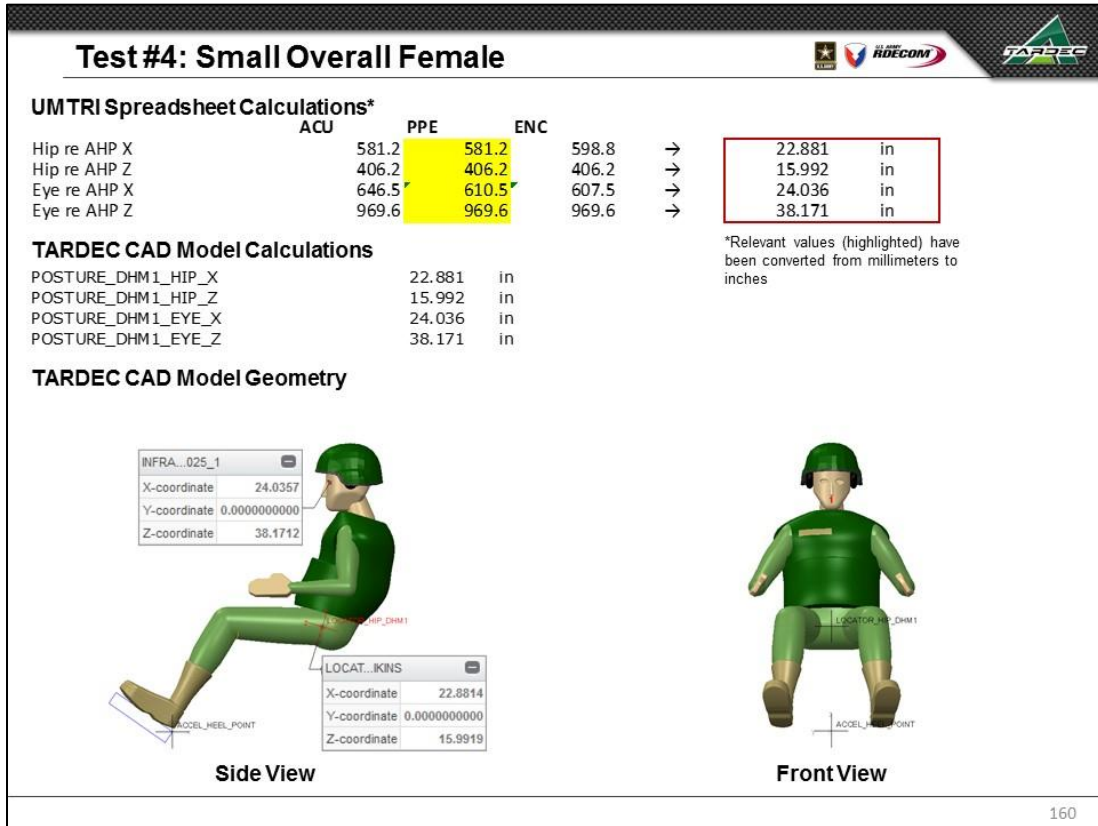

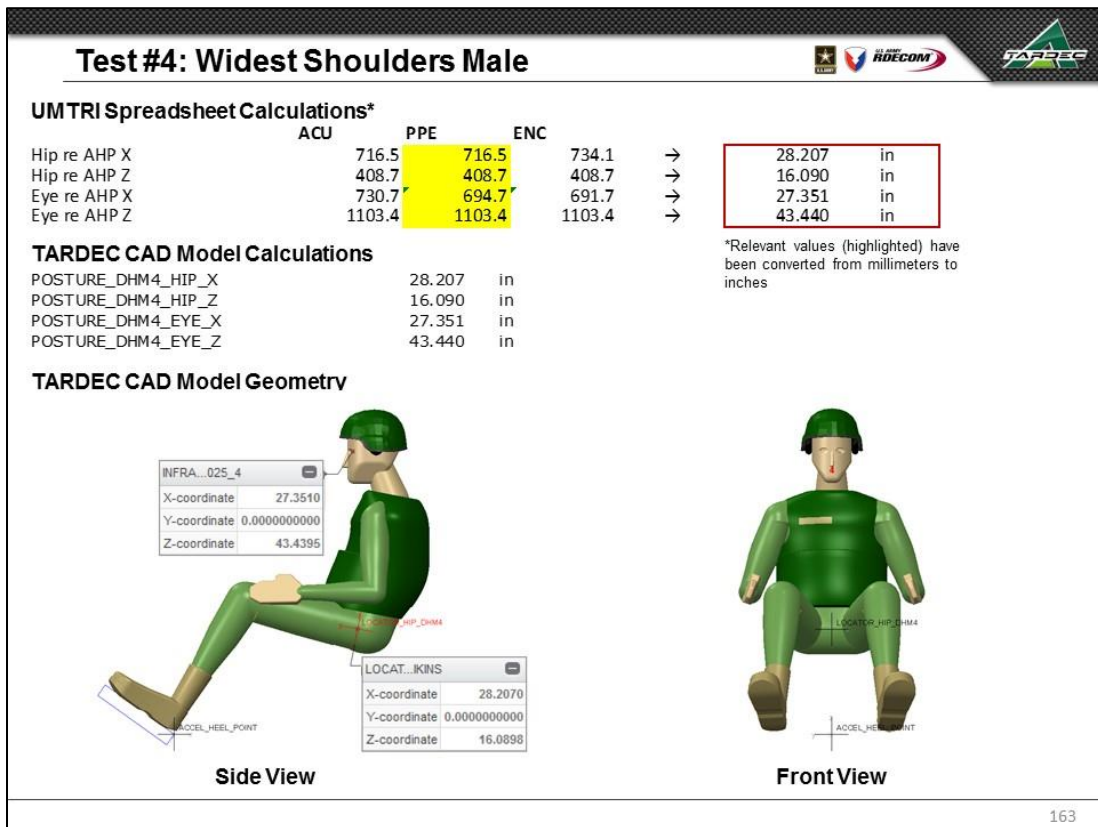
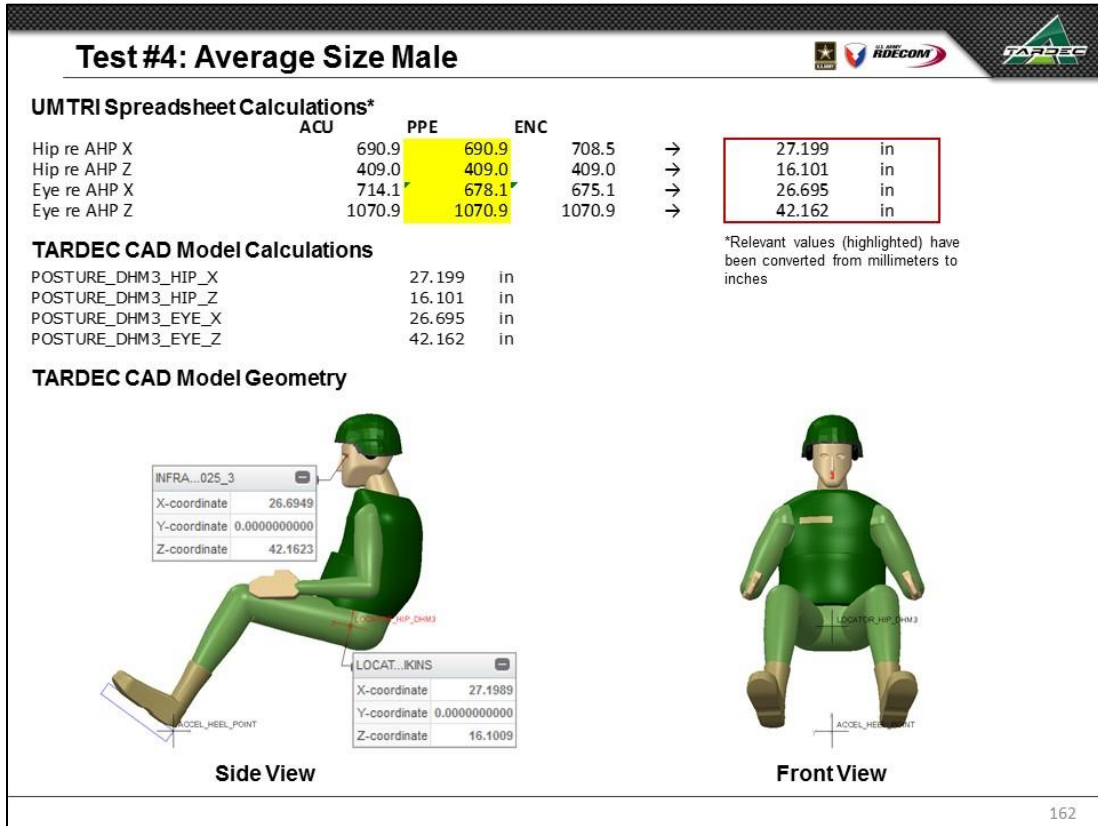

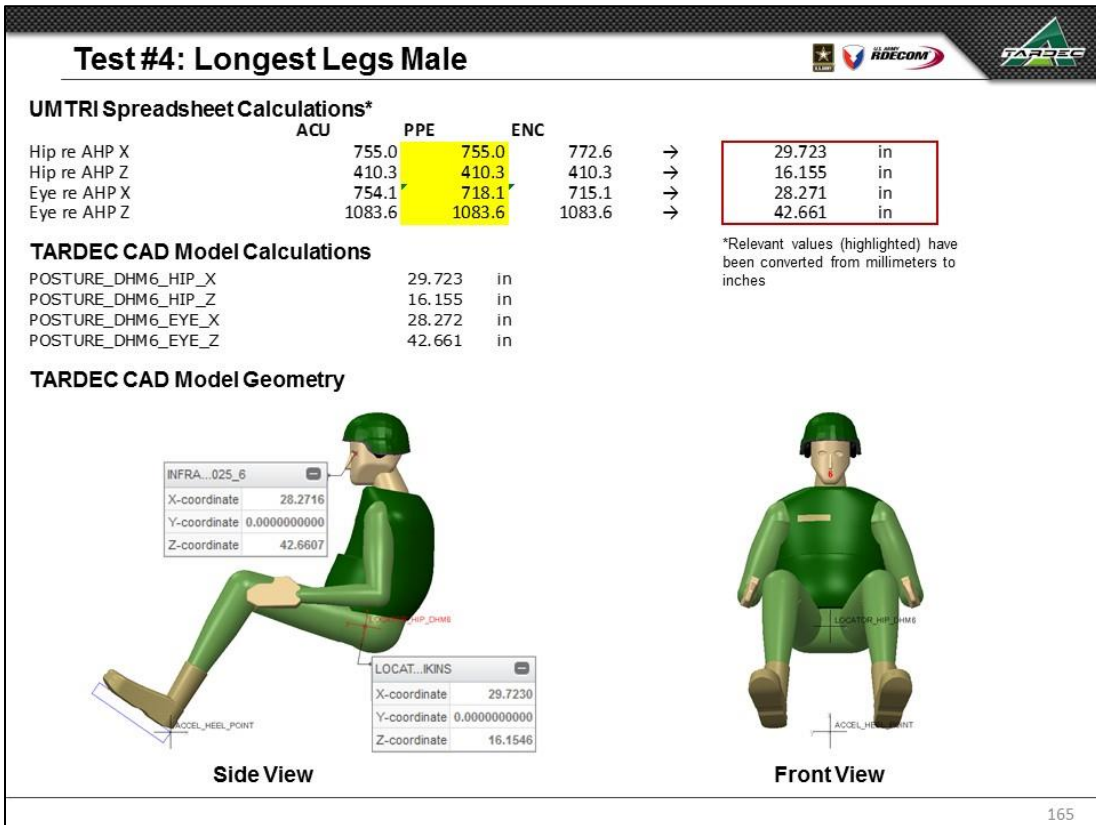
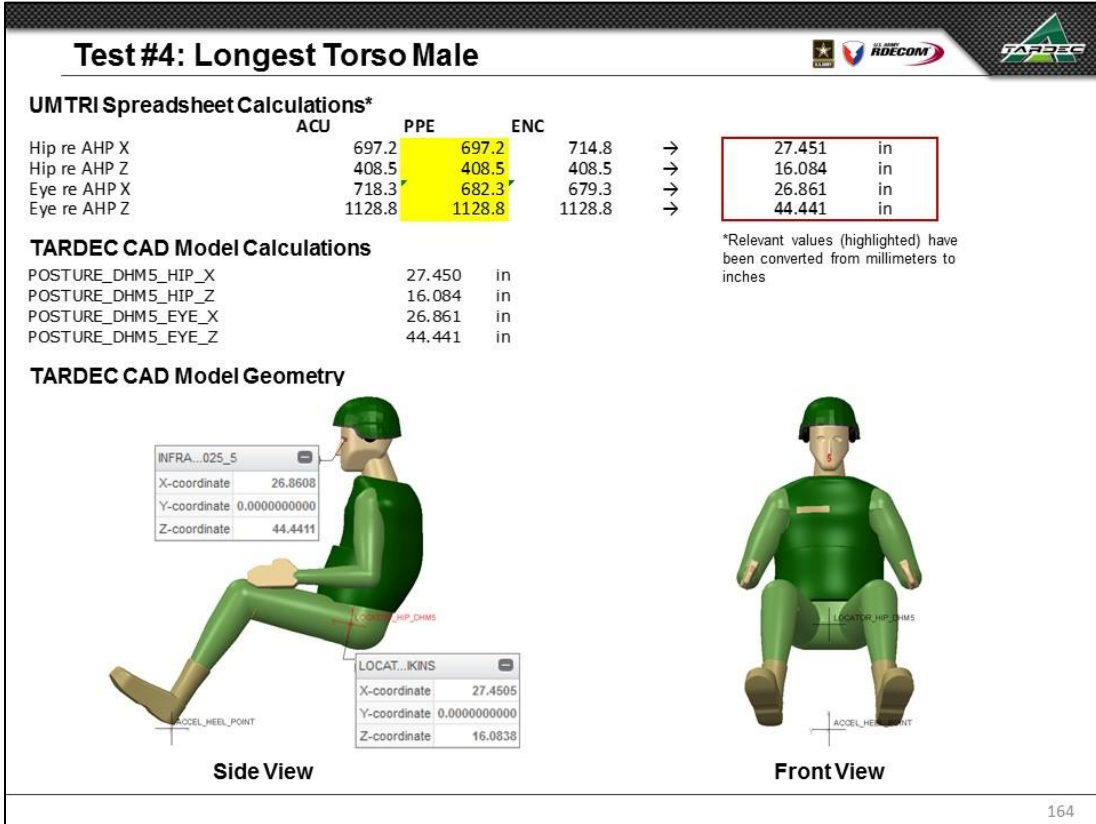

Test #4: Large Overall Male

UMTRI Spreadsheet Calculations*

	ACU	PPE	ENC		
Hip re AHP X	750.5	750.5	768.1	→	29.548 in
Hip re AHP Z	412.8	412.8	412.8	→	16.252 in
Eye re AHP X	748.4	712.4	709.4	→	28.048 in
Eye re AHP Z	1127.8	1127.8	1127.8	→	44.400 in

TARDEC CAD Model Calculations

POSTURE_DHM7_HIP_X	29.548	in
POSTURE_DHM7_HIP_Z	16.252	in
POSTURE_DHM7_EYE_X	28.048	in
POSTURE_DHM7_EYE_Z	44.400	in

TARDEC CAD Model Geometry

Side View

Front View

*Relevant values (highlighted) have been converted from millimeters to inches

166

10.7.5 TEST #5 – VARY SWP IN FORE-AFT (X) AND VERTICAL (Z) DIRECTION

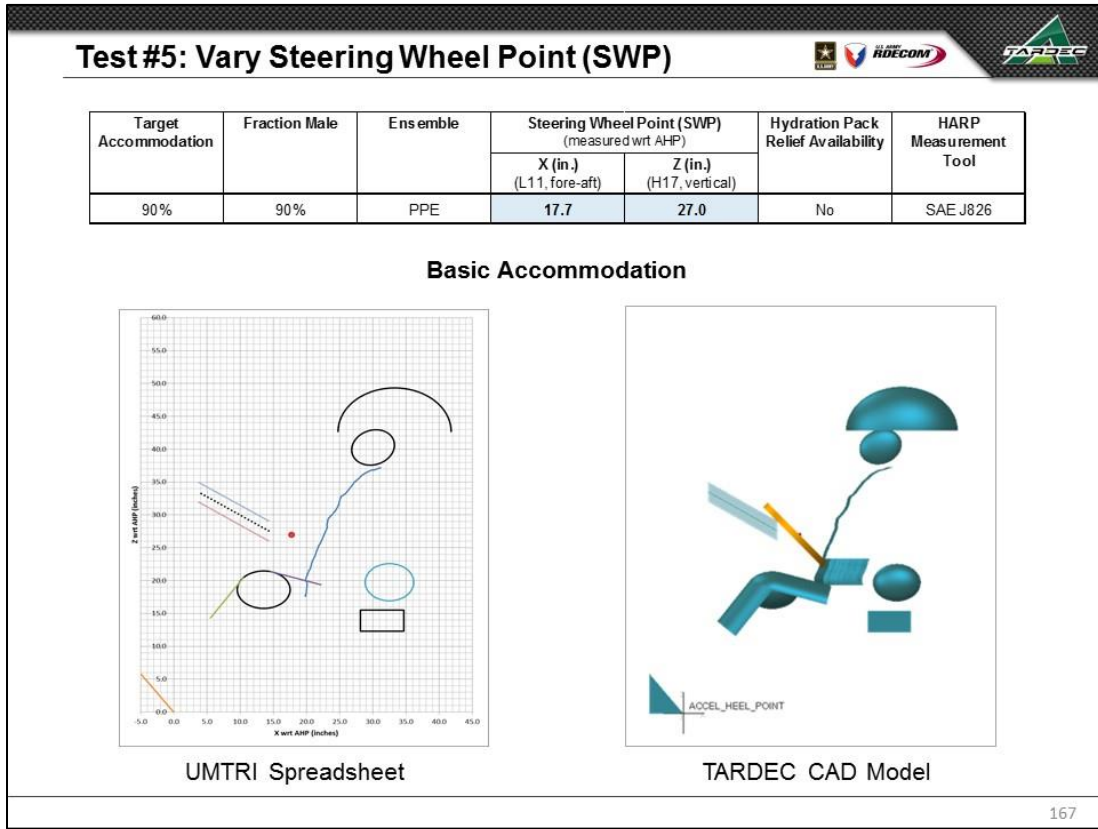

Test #5: Numerical Results, Accommodation

Surrogate Steering Wheel				Helmet Boundary			
	UMTRI Value	TARDEC Value	Difference		UMTRI Value	TARDEC Value	Difference
STEERING_WHEEL_X	17.700 in	17.700 in	0.000 in	HELMET_CONTOUR_CBTRD_X	33.269 in	33.269 in	0.000 in
STEERING_WHEEL_Z	27.000 in	27.000 in	0.000 in	HELMET_CONTOUR_CBTRD_Y (+/-)	2.185 in	2.185 in	0.000 in
Steering Wheel Preference Line				Knee Boundary			
	UMTRI Value	TARDEC Value	Difference		UMTRI Value	TARDEC Value	Difference
STRG_WHL_FWD_X	14.297 in	14.297 in	0.000 in	KNEE_CONTOUR_WEIGHTED_CENT_X	13.535 in	13.535 in	0.000 in
STRG_WHL_FWD_Z	27.559 in	27.559 in	0.000 in	KNEE_CONTOUR_WEIGHTED_CENT_Y (+/-)	7.087 in	7.087 in	0.000 in
STRG_WHL_RWD_X	3.733 in	3.733 in	0.000 in	KNEE_CONTOUR_WEIGHTED_CENT_Z	18.619 in	18.619 in	0.000 in
STRG_WHL_RWD_Z	33.465 in	33.465 in	0.000 in	KNEE_CONTOUR_X_AXIS_LENGTH	7.969 in	7.971 in	0.002 in
Steering Wheel Preference Zone				Elbow Boundary			
	UMTRI Value	TARDEC Value	Difference		UMTRI Value	TARDEC Value	Difference
STRG_WHL_ZONE_Z	1.516 in	1.516 in	0.001 in	ELBOW_WEIGHTED_CBNT_X	32.493 in	32.493 in	0.000 in
STRG_WHL_ZONE_Y	N/A	1.000 in	N/A	ELBOW_WEIGHTED_CBNT_Y (+/-)	12.353 in	12.353 in	0.000 in
Accelerator Plane Angle (APA)				Torso Boundary			
	UMTRI Value	TARDEC Value	Difference		UMTRI Value	TARDEC Value	Difference
ACCEL_PEDAL_PLANE_ANG	49.214 deg	49.214 deg	0.000 deg	TORSO_WEIGHTED_REF_PT_PFE_X	25.261 in	25.260 in	0.001 in
Origin (X)	0.000 in	0.000 in	0.000 in	TORSO_WEIGHTED_REF_PT_PFE_Z	31.211 in	31.211 in	0.000 in
Origin (Z)	0.000 in	0.000 in	0.000 in	Seat Track Travel Range			
BOFRP (X)	-5.144 in	-5.144 in	0.000 in	SEAT_POSITION_CTR_OF_TRAVEL_X	31.393 in	31.394 in	0.001 in
BOFRP (Z)	5.962 in	5.962 in	0.000 in	SEAT_POSITION_CTR_OF_TRAVEL_Z	13.908 in	13.908 in	0.000 in
Seat Back Angle				SEAT_POSITION_FORE_AFT_TRAVEL	6.533 in	6.535 in	0.001 in
	UMTRI Value	TARDEC Value	Difference	SEAT_POSITION_VERTICAL_TRAVEL	3.222 in	3.223 in	0.001 in
SEAT_BACK_ANGLE_LOWER_QUANTILE	17.572 deg	17.568 deg	0.004 deg	Seat Back Angle			
SEAT_BACK_ANGLE_UPPER_QUANTILE	27.770 deg	27.774 deg	0.004 deg	SEAT_BACK_ANGLE_LOWER_QUANTILE	17.572 deg	17.568 deg	0.004 deg
Eyellipse				SEAT_BACK_ANGLE_UPPER_QUANTILE	27.770 deg	27.774 deg	0.004 deg
	UMTRI Value	TARDEC Value	Difference	Eyellipse			
EYELLIPSE_CENTROID_X	30.025 in	30.025 in	0.000 in	EYELLIPSE_CENTROID_X	30.025 in	30.025 in	0.000 in
EYELLIPSE_CENTROID_Y (+/-)	1.280 in	1.280 in	0.000 in	EYELLIPSE_CENTROID_Y (+/-)	1.280 in	1.280 in	0.000 in
EYELLIPSE_CENTROID_Z	40.266 in	40.266 in	0.000 in	EYELLIPSE_CENTROID_Z	40.266 in	40.266 in	0.000 in
EYELLIPSE_ANGLE_REL_X	18.600 deg	18.600 deg	0.000 deg	EYELLIPSE_ANGLE_REL_X	18.600 deg	18.600 deg	0.000 deg
EYELLIPSE_X_AXIS_LENGTH	6.570 in	6.573 in	0.003 in	EYELLIPSE_X_AXIS_LENGTH	6.570 in	6.573 in	0.003 in
EYELLIPSE_Y_AXIS_LENGTH	1.917 in	1.918 in	0.001 in	EYELLIPSE_Y_AXIS_LENGTH	1.917 in	1.918 in	0.001 in
EYELLIPSE_Z_AXIS_LENGTH	5.236 in	5.240 in	0.004 in	EYELLIPSE_Z_AXIS_LENGTH	5.236 in	5.240 in	0.004 in

TARDEC CAD values to agree with UMTRI spreadsheet values within
 ±0.100 inches
 ±0.100 degrees

Largest Observed Differences:
 0.004 inches
 0.004 degrees

Values in agreement

168

Test #5: Surrogate Steering Wheel

UMTRI Spreadsheet Calculations

	L11	H17
	(in)	(in)
Steering Wheel Point (SWP)	17.700	27.000

TARDEC CAD Model Calculations

STEERING_WHEEL_X	17.700	in
STEERING_WHEEL_Z	27.000	in

TARDEC CAD Model Geometry

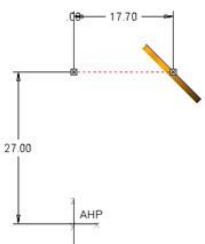

Side View

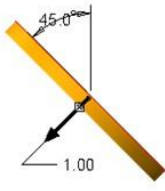

Side View

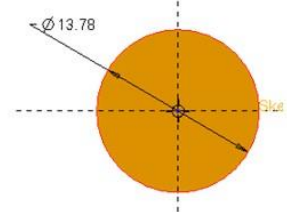

Normal to Steering Wheel

Steering Wheel Geometry

Unclassified // For Official Use Only

169

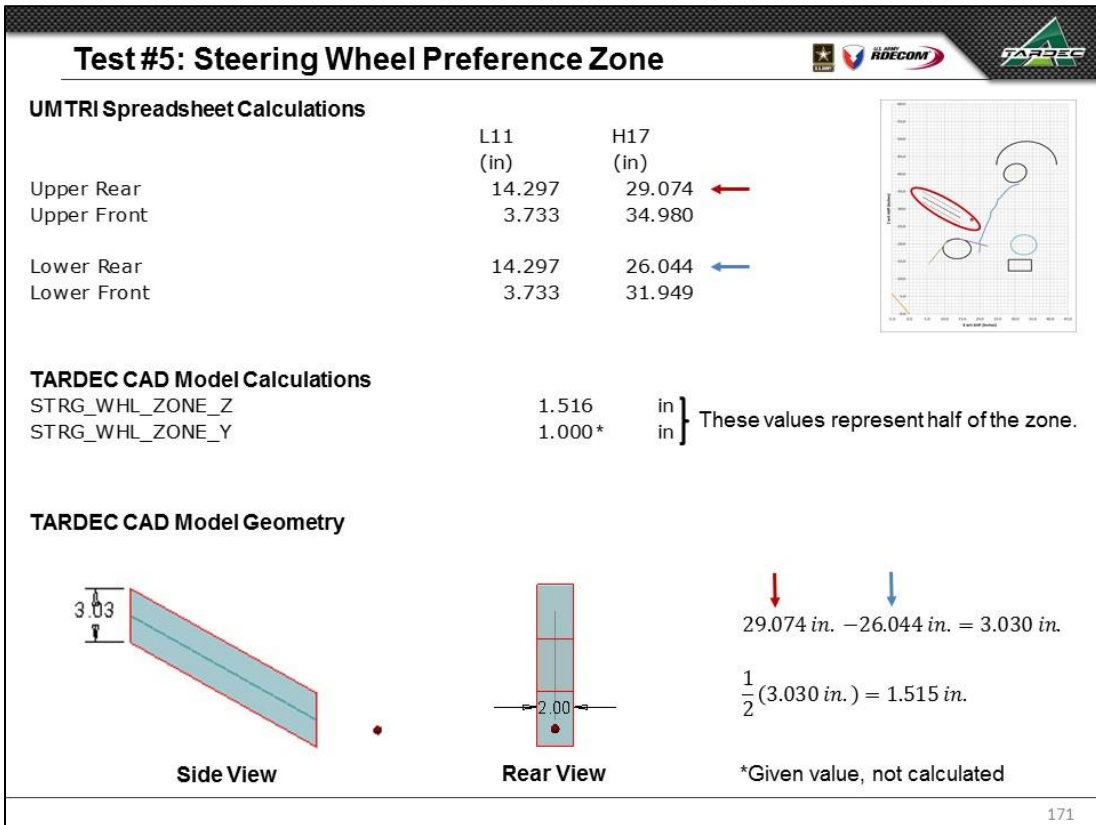
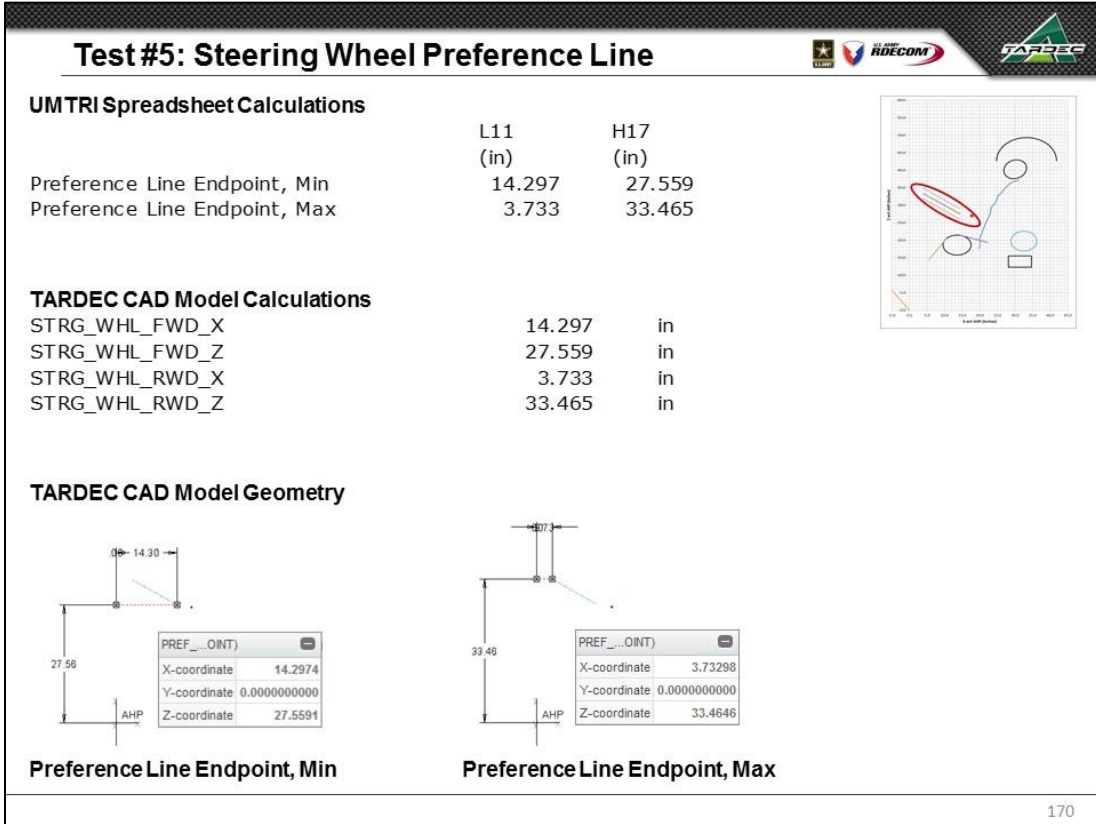

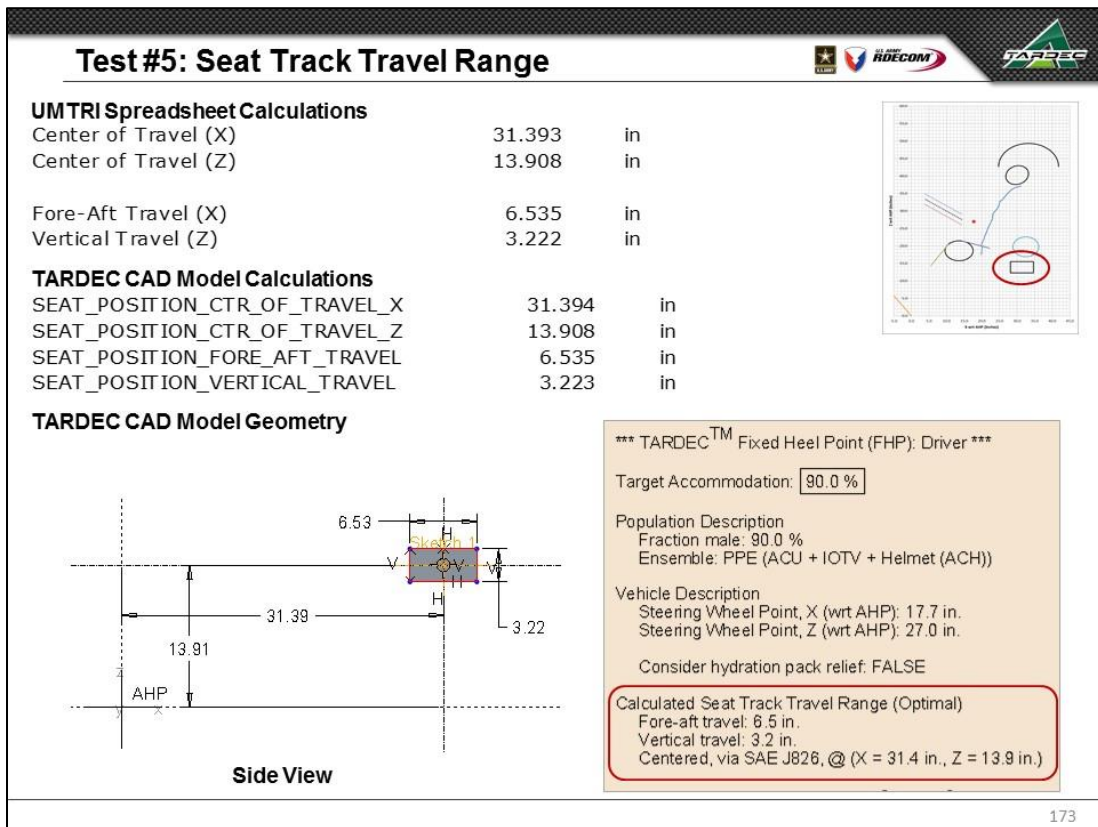
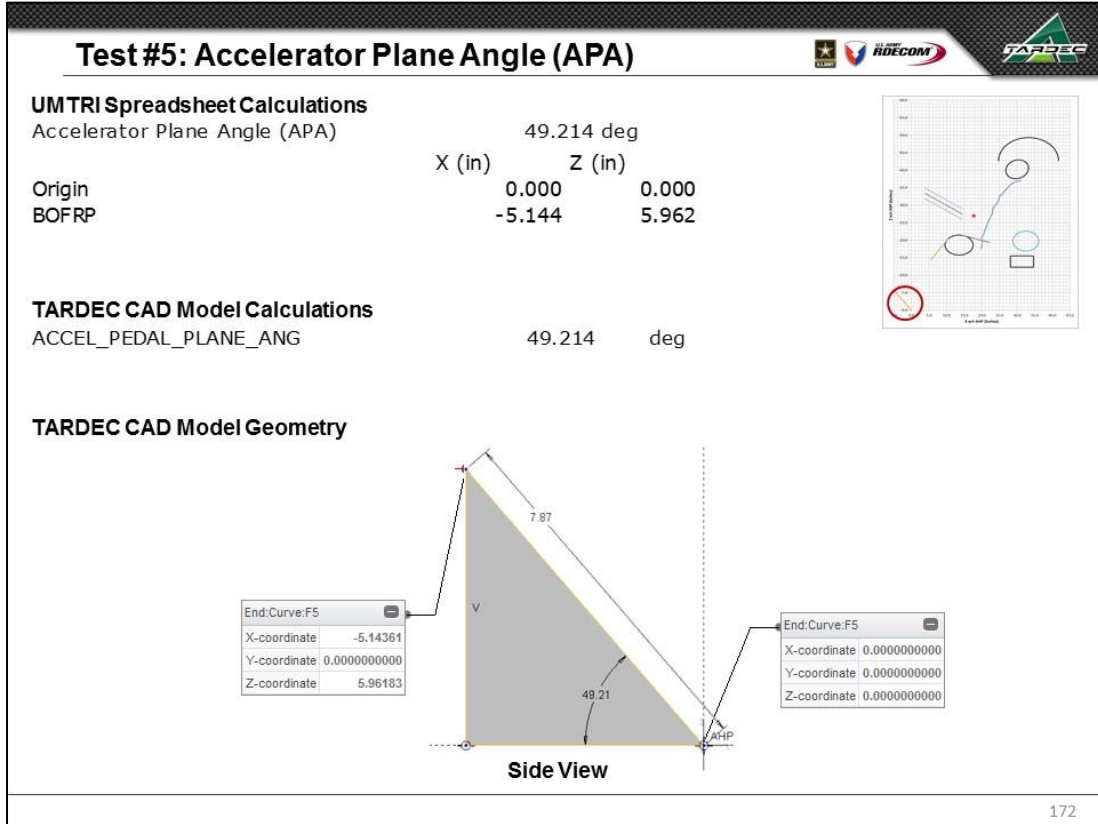

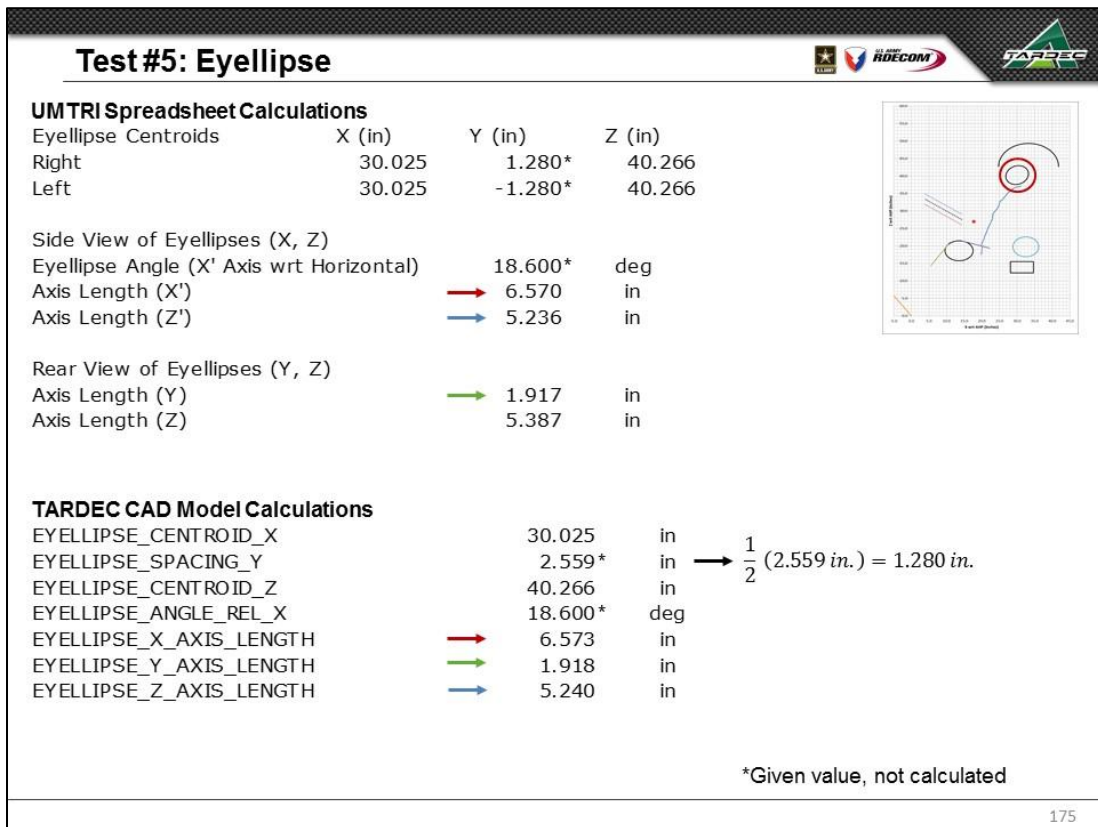
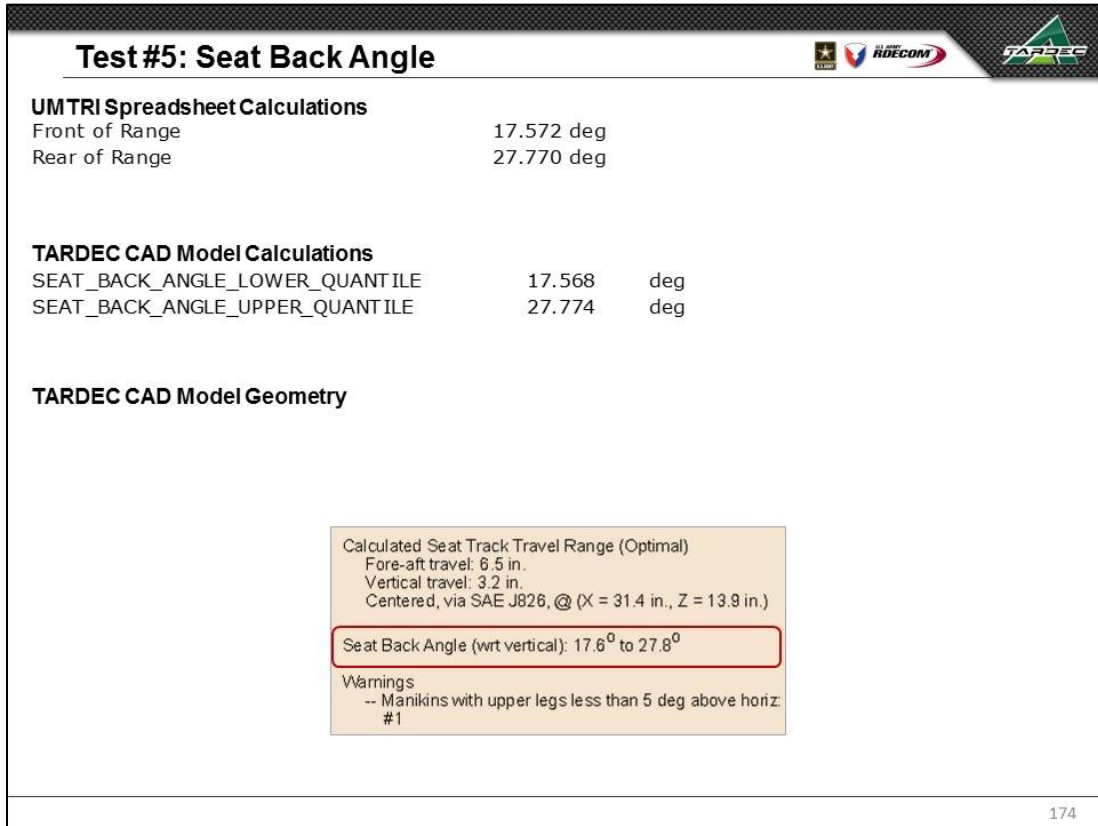

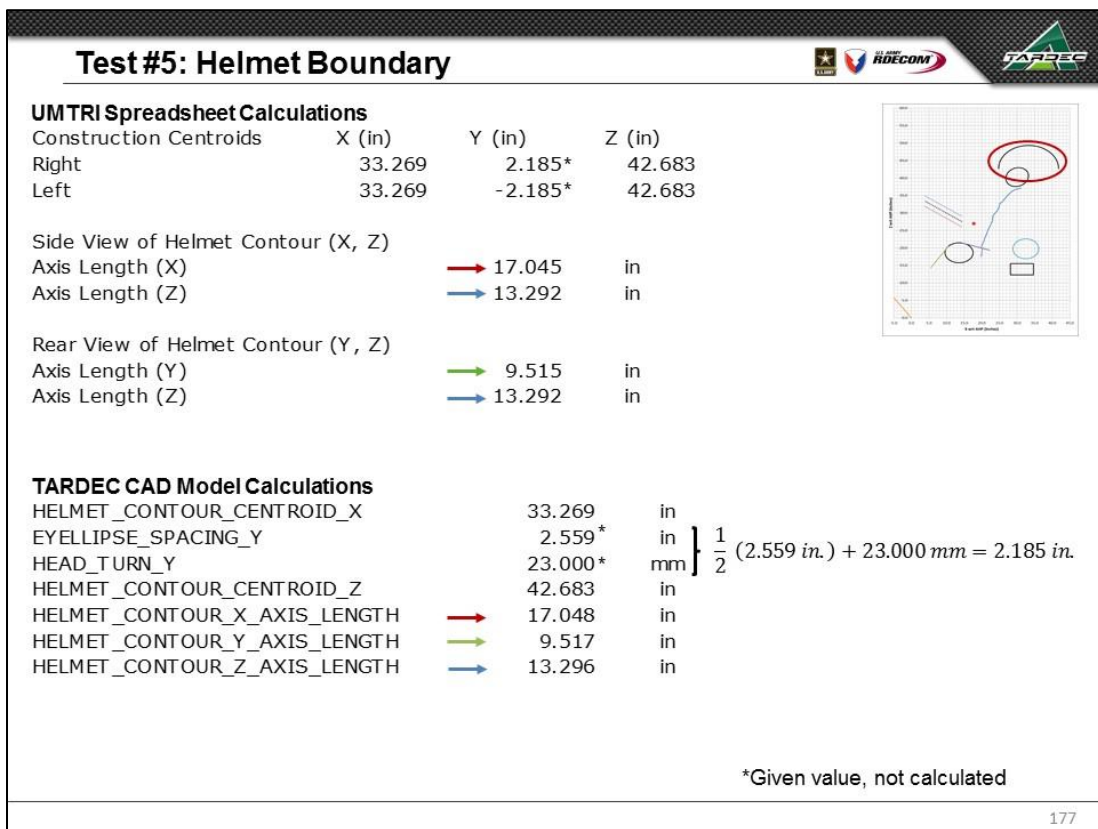
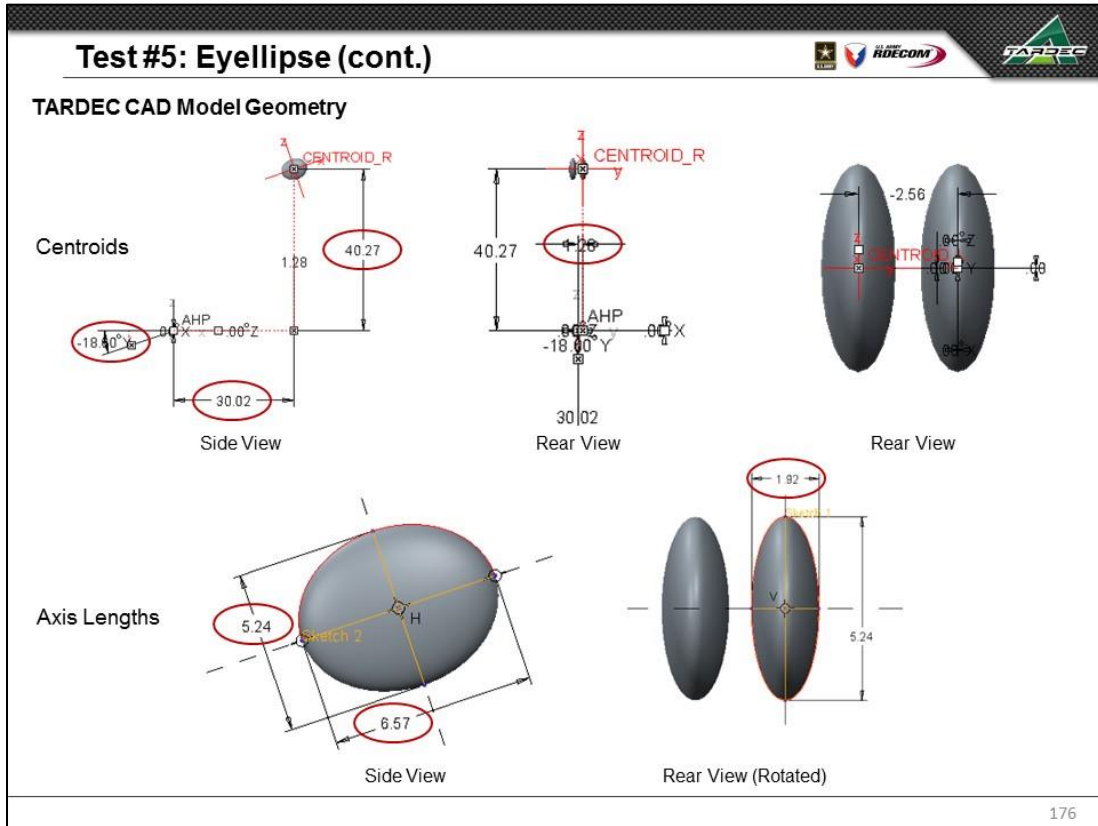

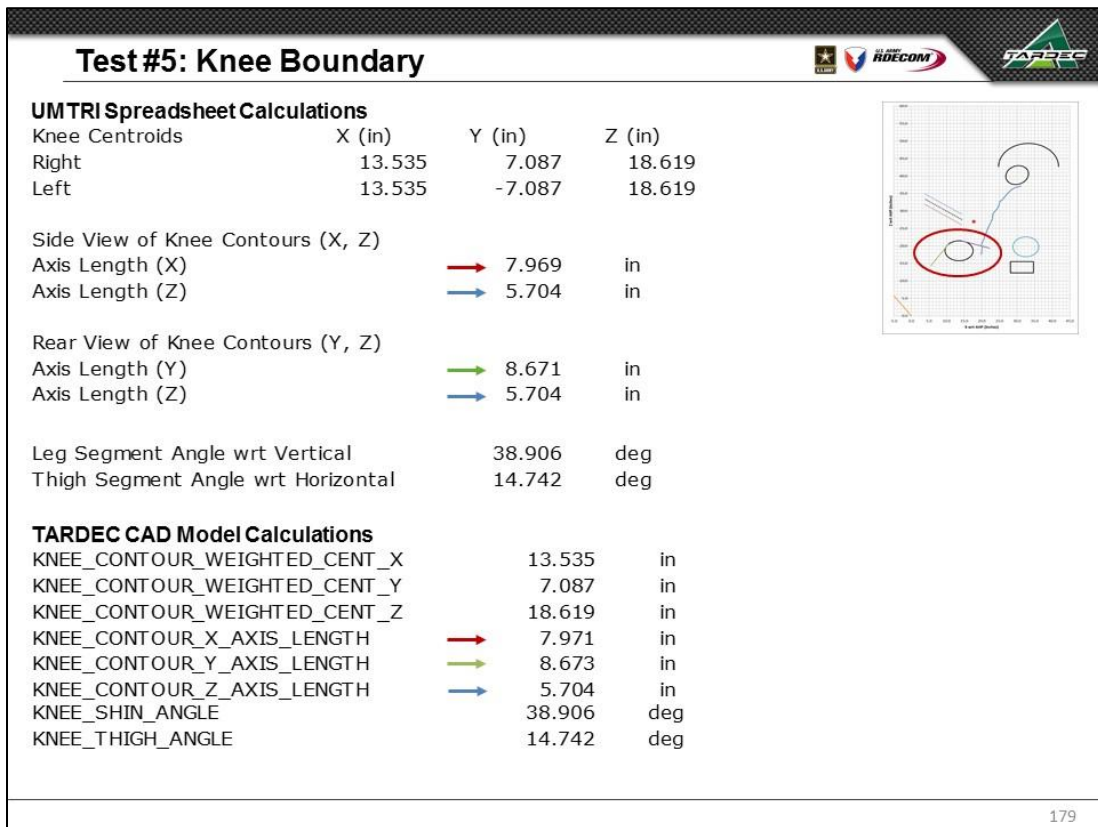
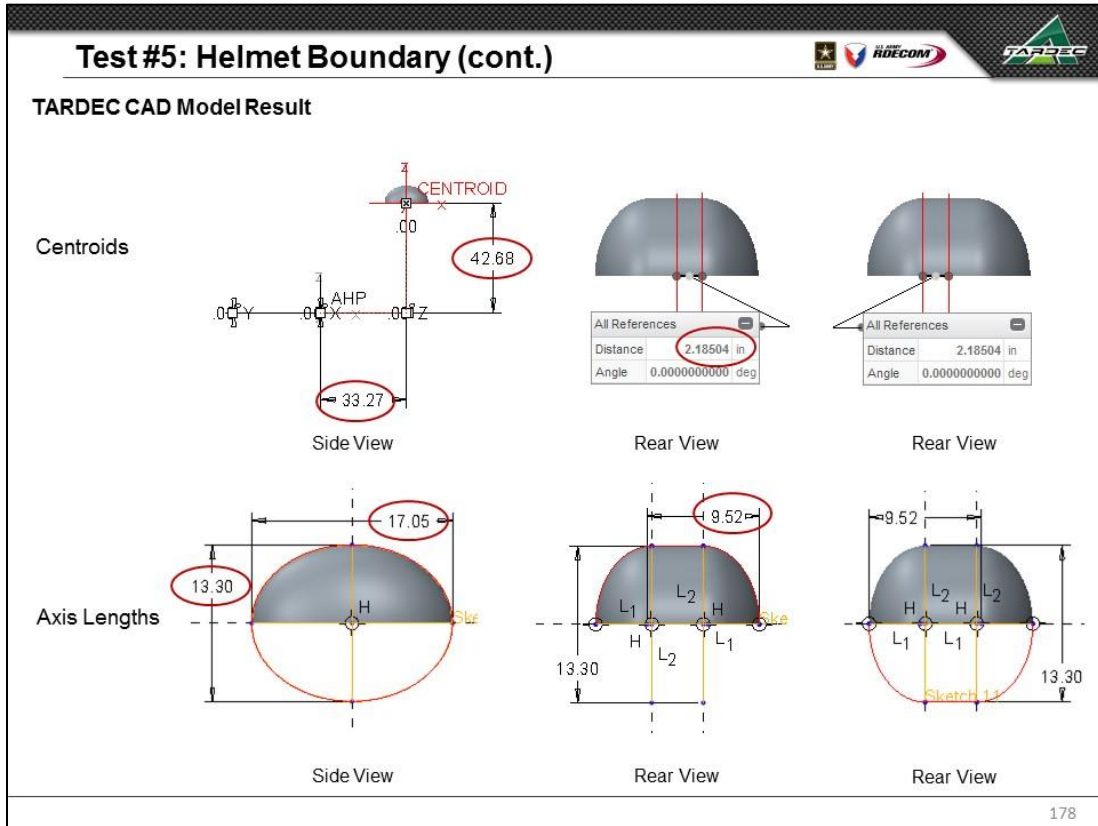

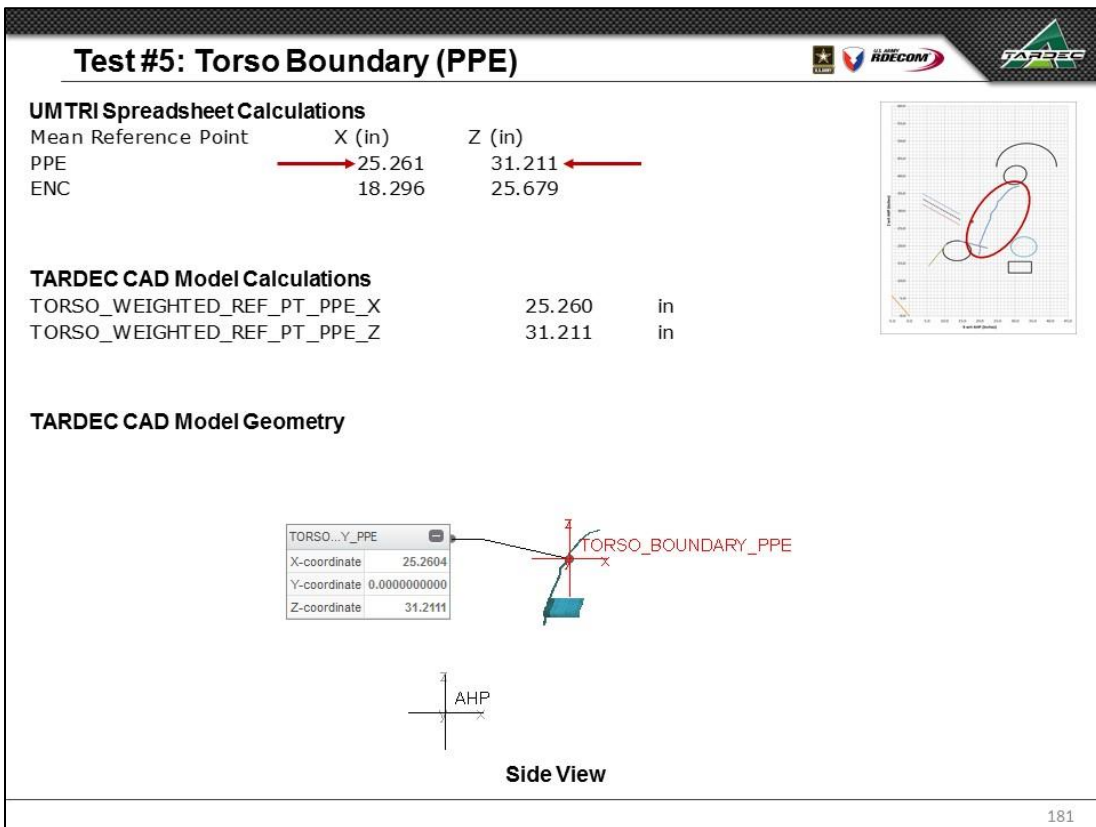
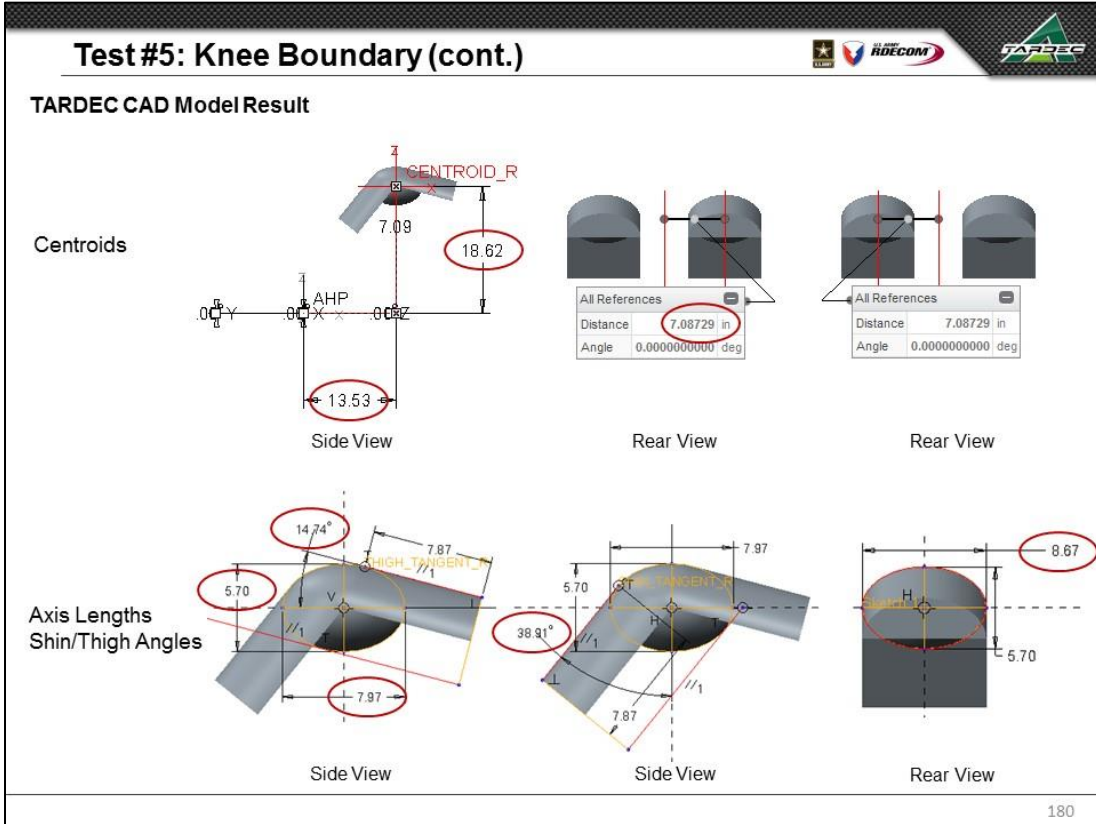

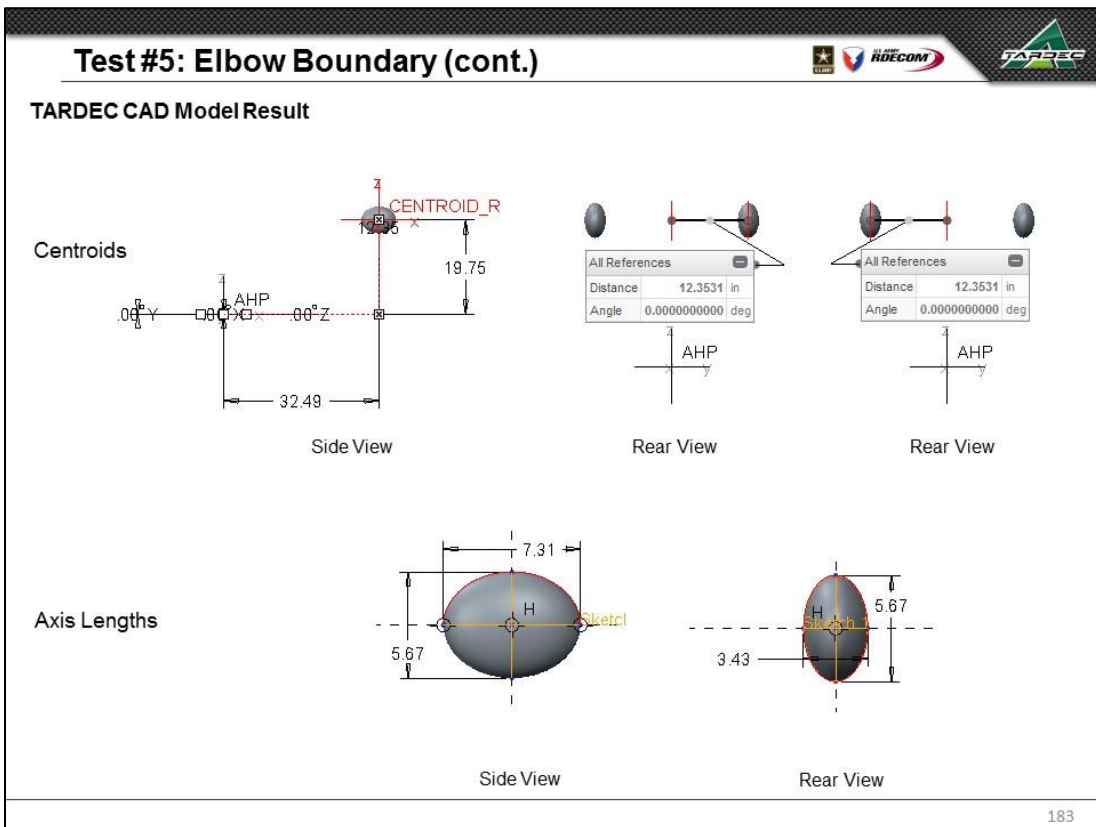
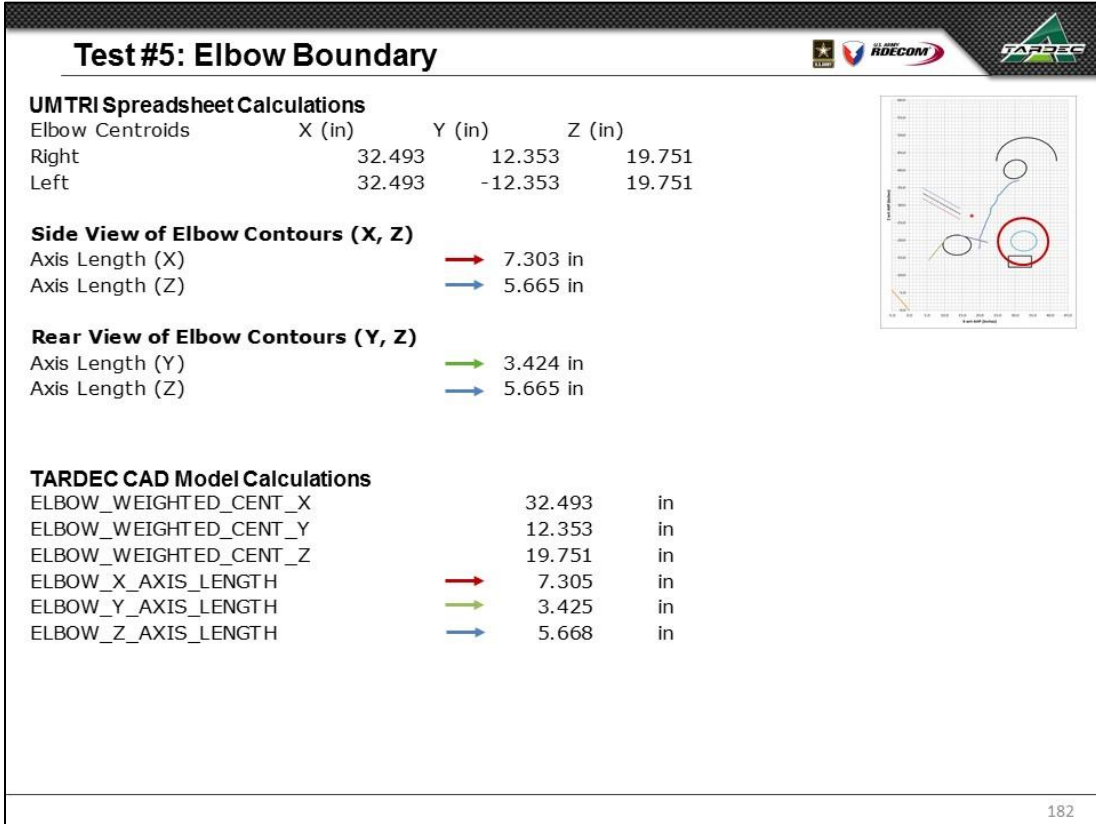

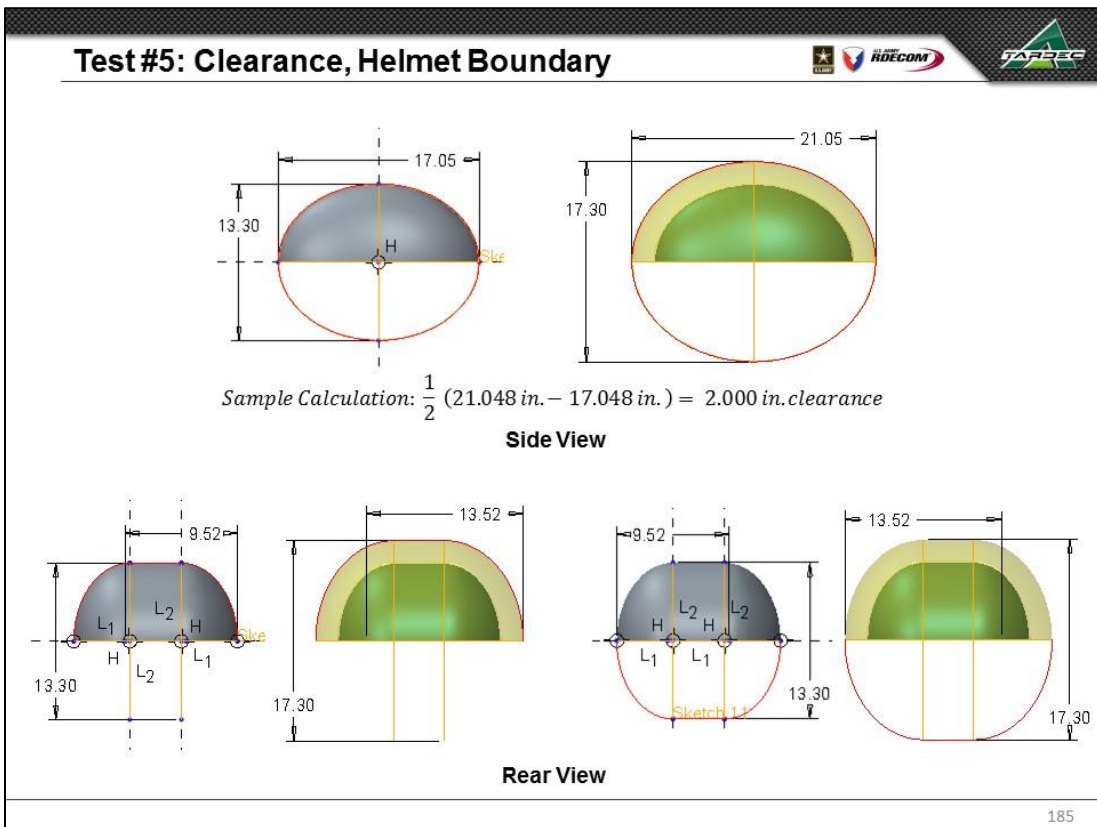
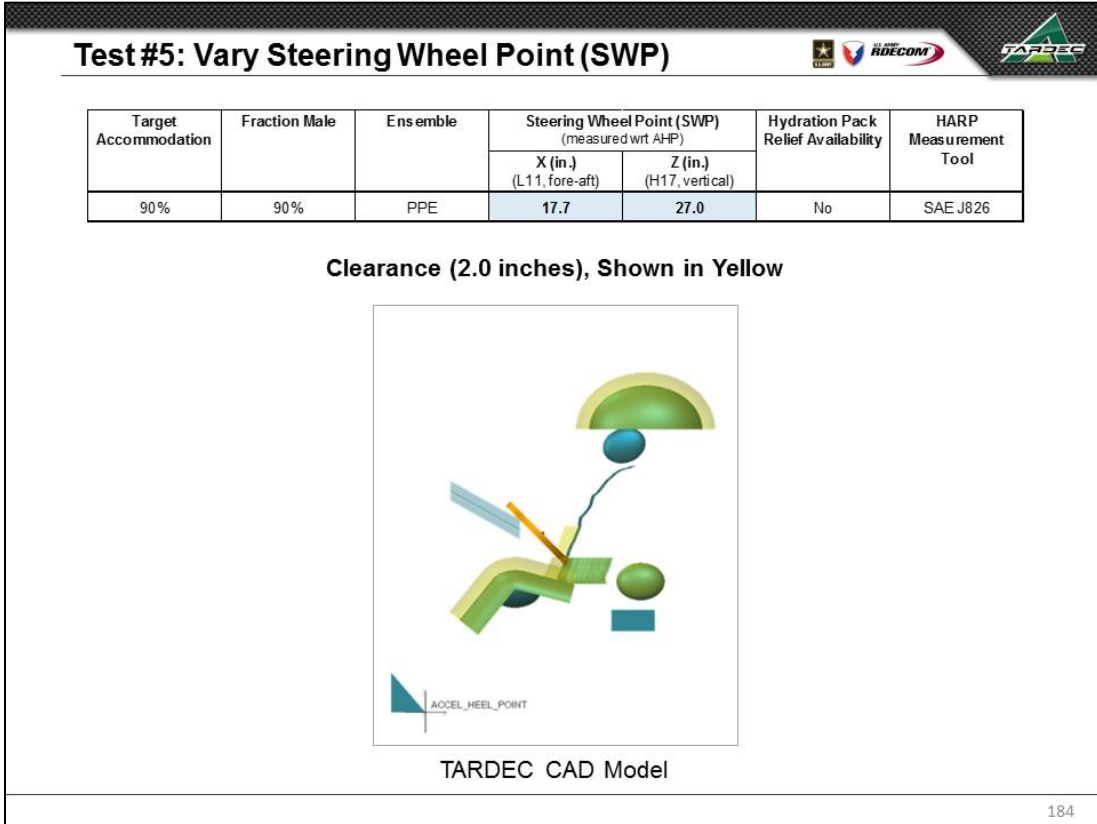

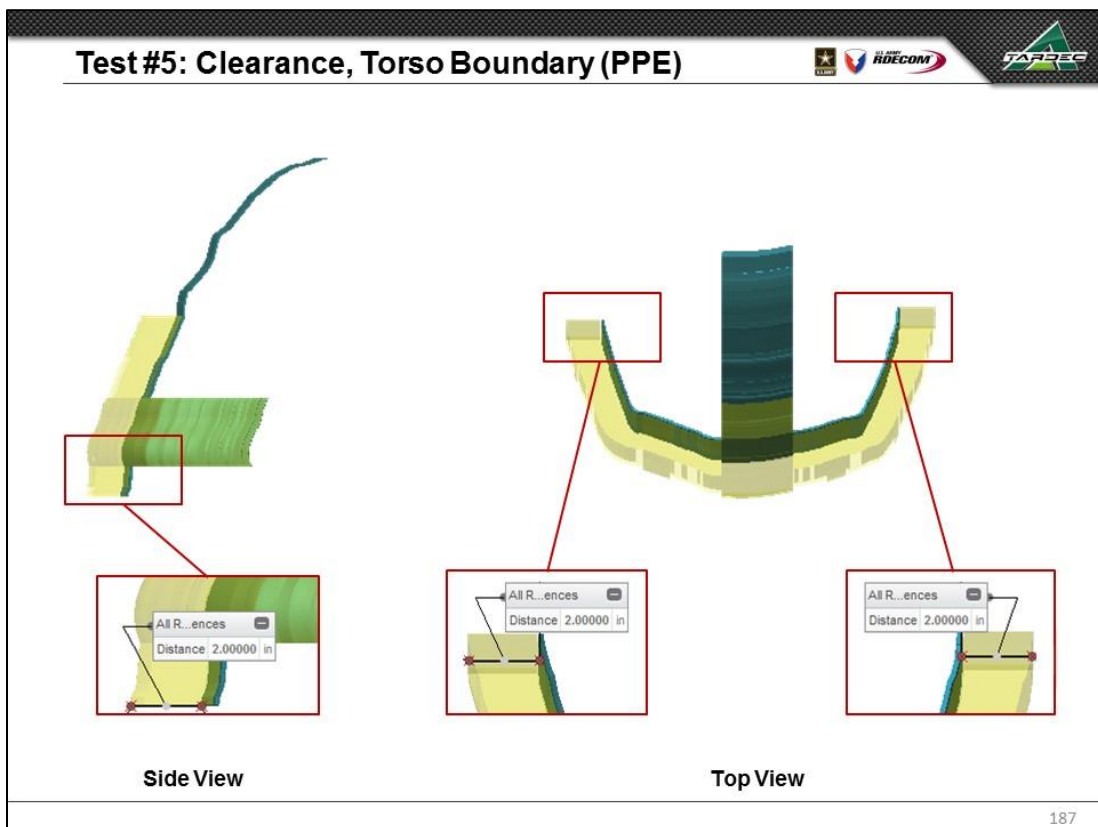
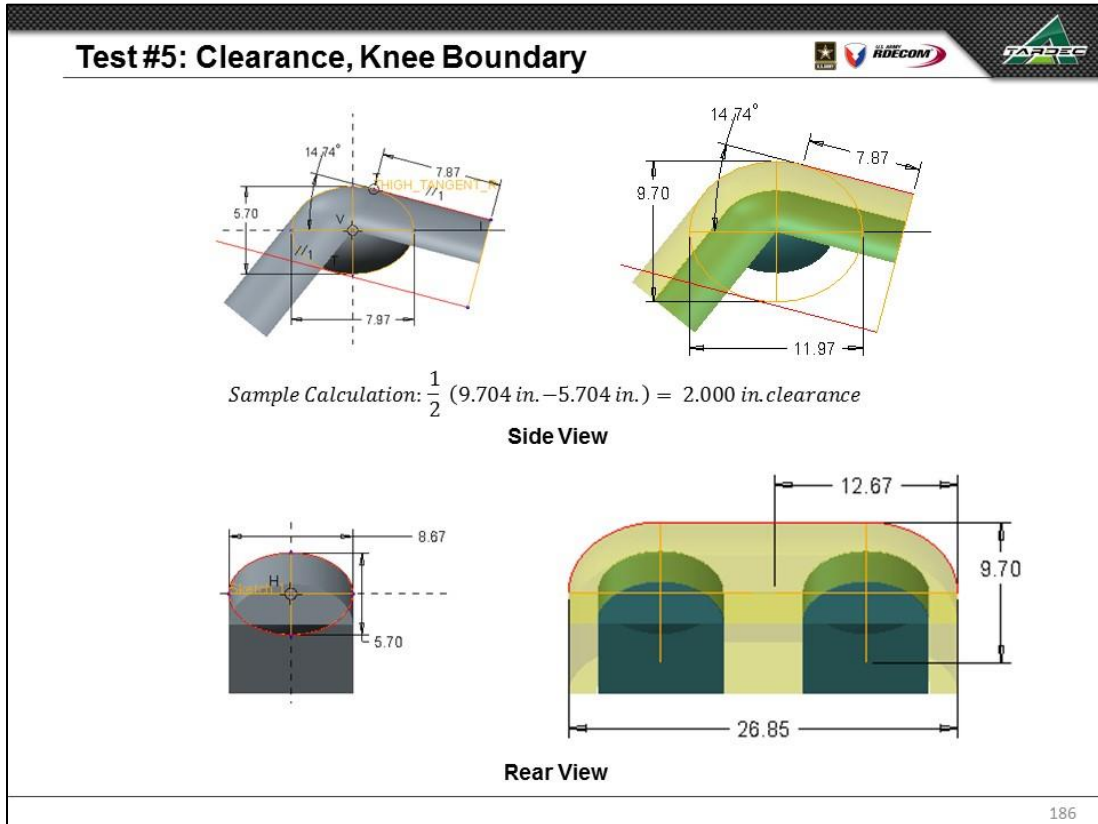

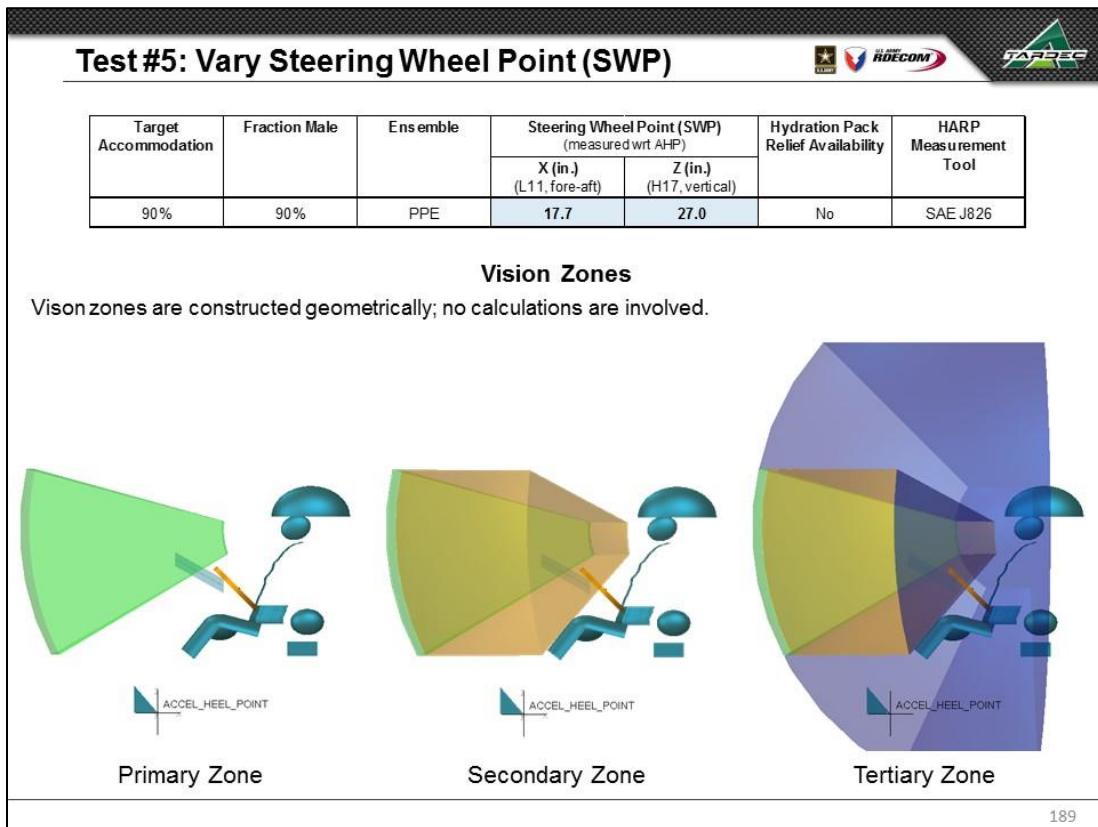
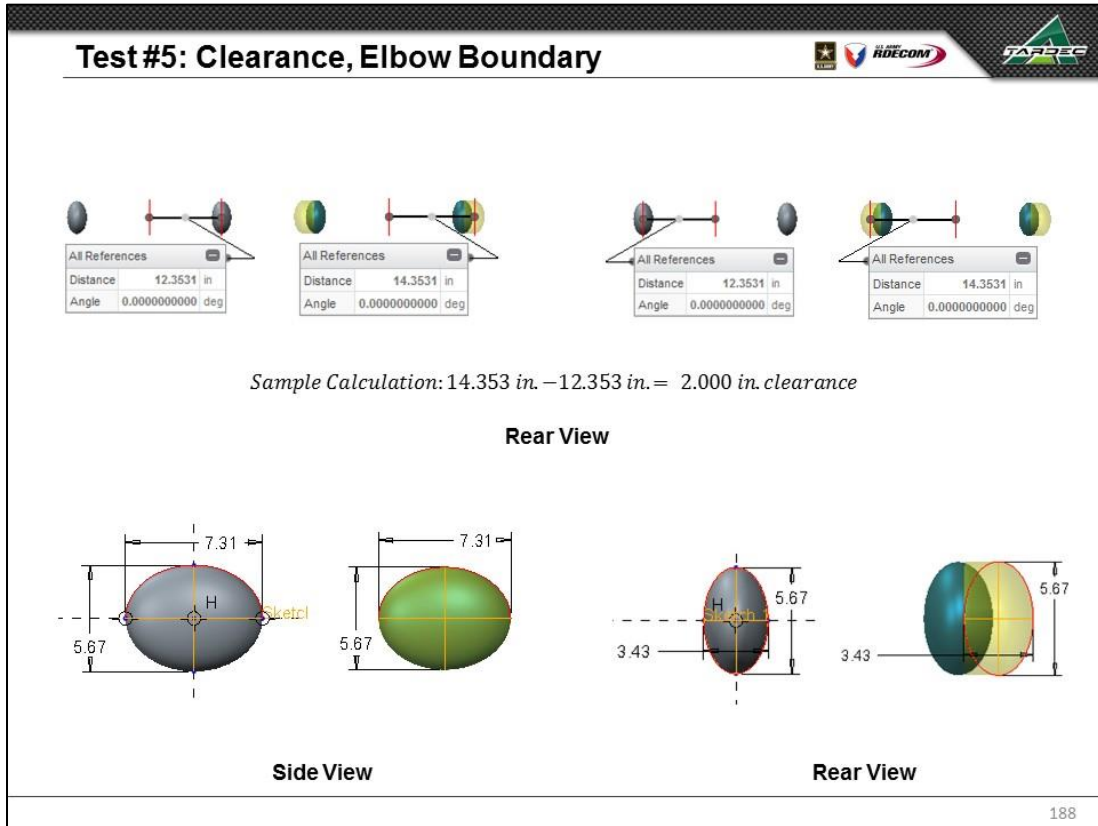

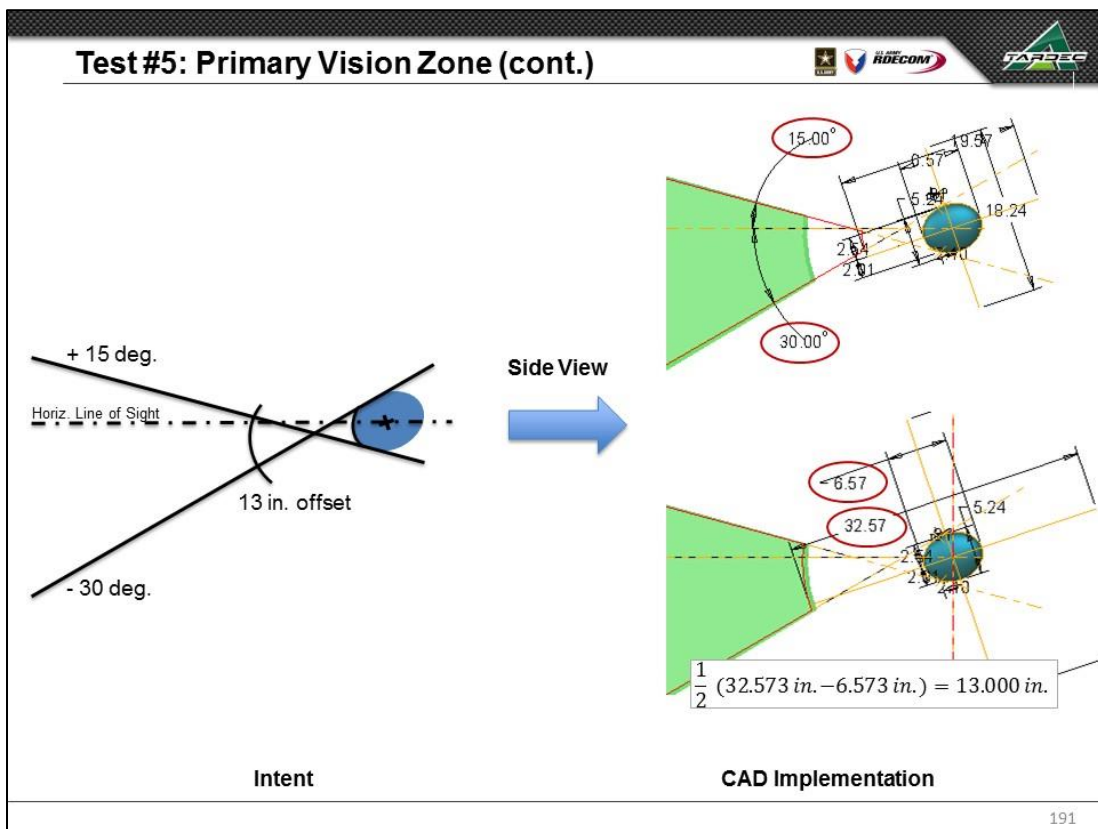
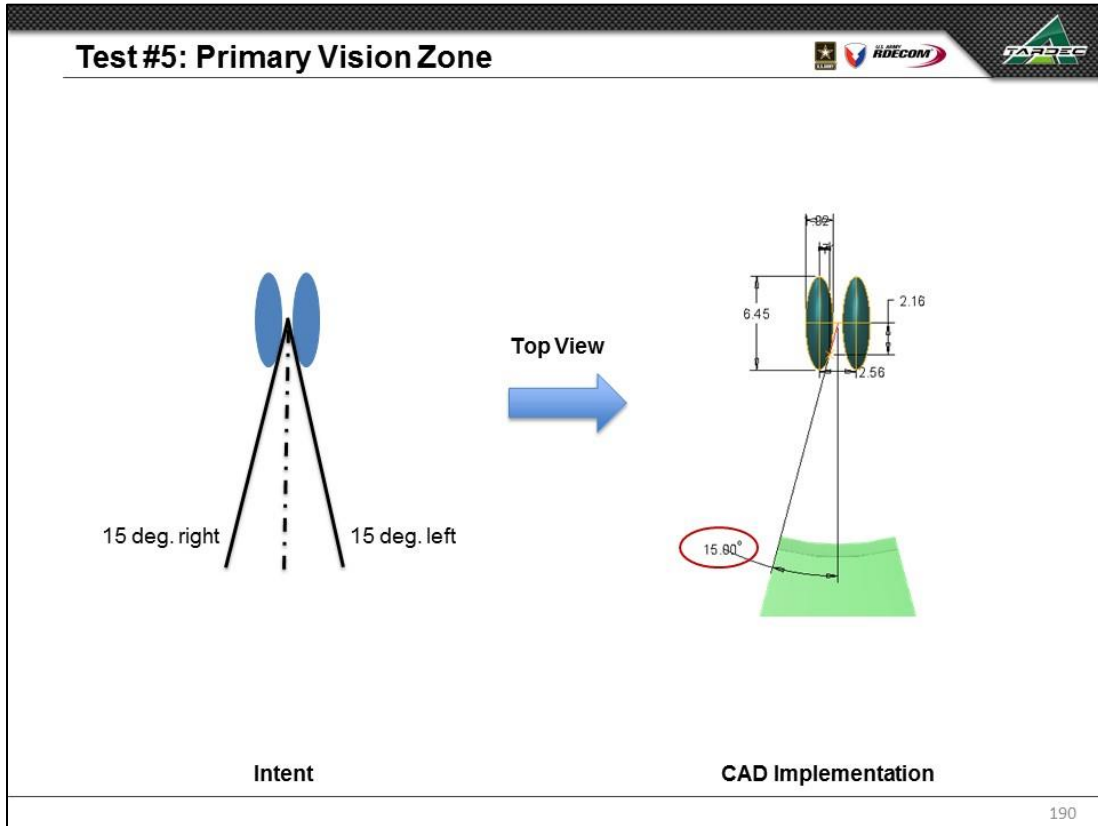

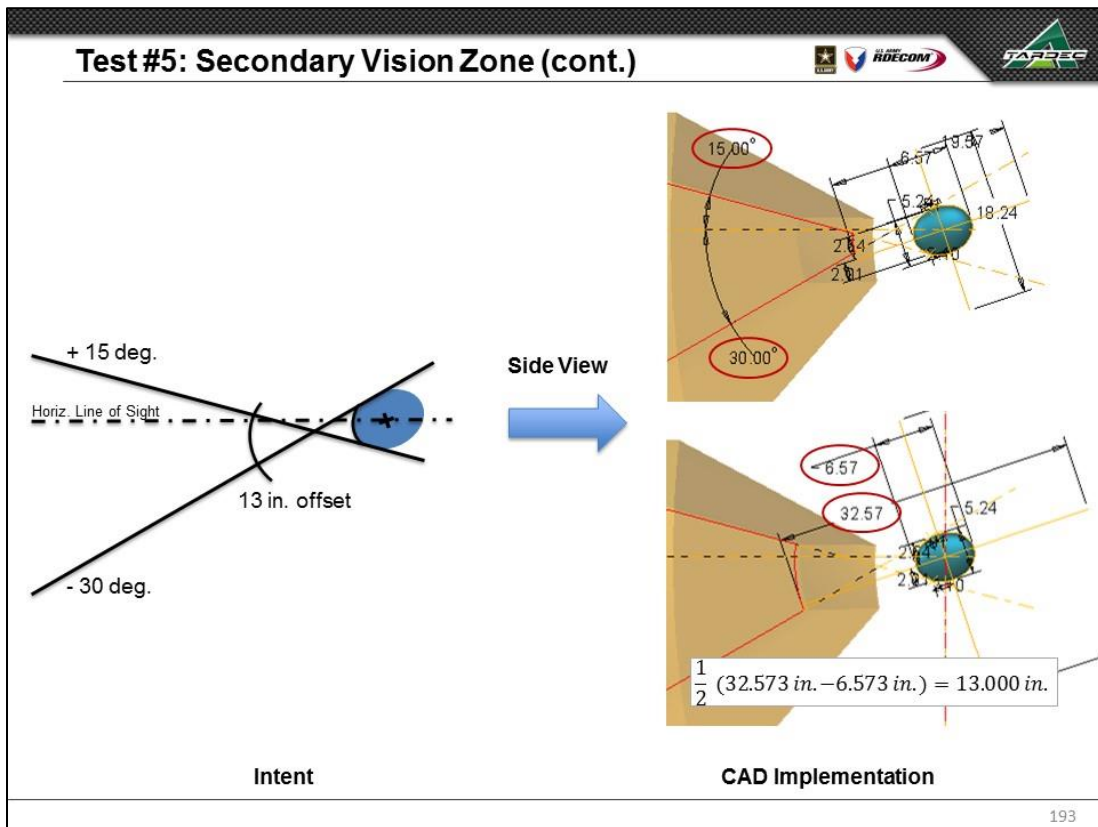
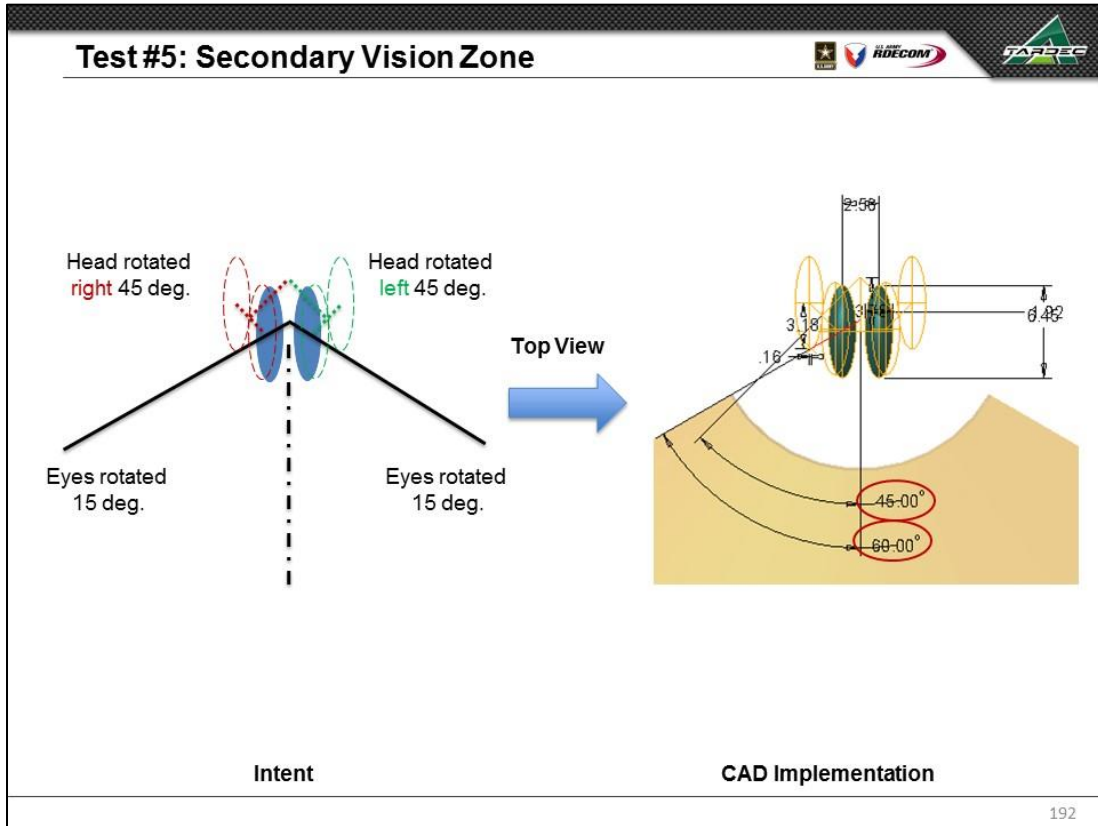

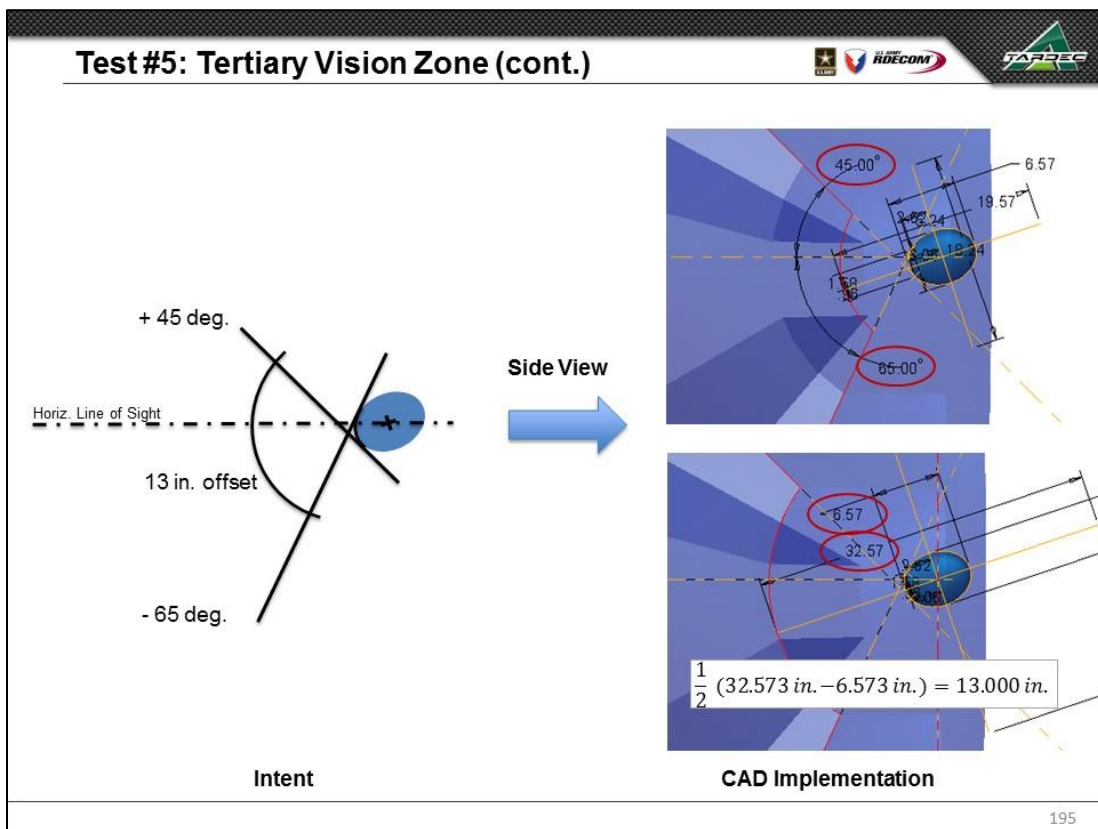
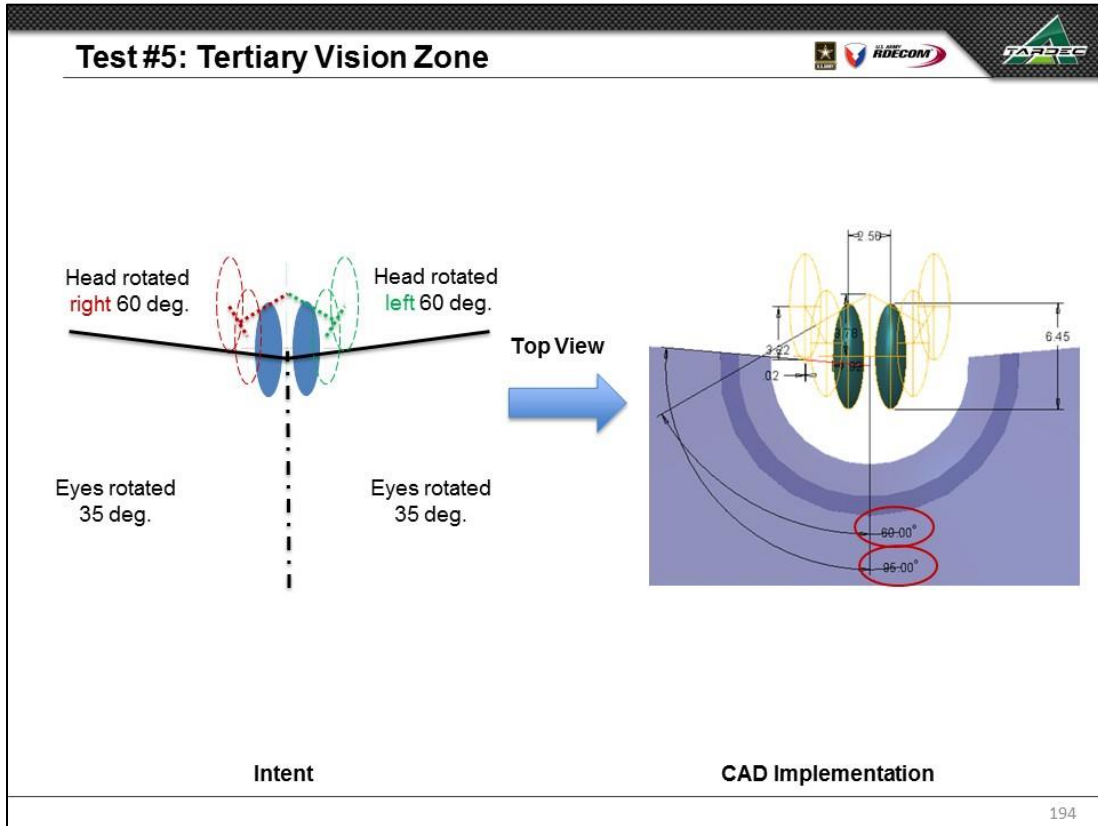



Test #5: Vary Steering Wheel Point (SWP)



Target Accommodation	Fraction Male	Ensemble	Steering Wheel Point (SWP) (measured wrt AHP)		Hydration Pack Relief Availability	HARP Measurement Tool
			X (in.) (L11, fore-aft)	Z (in.) (H17, vertical)		
90%	90%	PPE	17.7	27.0	No	SAE J826

Boundary Manikin Posture and Position



TARDEC CAD Model

196

Test #5: Numerical Results, Manikin Positioning



Small Overall Female			
	UMTRI Value	TARDEC Value	Difference
POSTURE_DHM1_HIP_X	26.711 in	26.711 in	0.000 in
POSTURE_DHM1_HIP_Z	13.602 in	13.602 in	0.000 in
POSTURE_DHM1_EYE_X	28.293 in	28.293 in	0.000 in
POSTURE_DHM1_EYE_Z	36.111 in	36.111 in	0.000 in
Small Overall Male			
	UMTRI Value	TARDEC Value	Difference
POSTURE_DHM2_HIP_X	28.833 in	28.833 in	0.000 in
POSTURE_DHM2_HIP_Z	13.712 in	13.712 in	0.000 in
POSTURE_DHM2_EYE_X	29.543 in	29.543 in	0.000 in
POSTURE_DHM2_EYE_Z	37.878 in	37.878 in	0.000 in
Average Size Male			
	UMTRI Value	TARDEC Value	Difference
POSTURE_DHM3_HIP_X	31.029 in	31.029 in	0.000 in
POSTURE_DHM3_HIP_Z	13.711 in	13.711 in	0.000 in
POSTURE_DHM3_EYE_X	30.952 in	30.952 in	0.000 in
POSTURE_DHM3_EYE_Z	40.102 in	40.102 in	0.000 in
Widest Shoulders Male			
	UMTRI Value	TARDEC Value	Difference
POSTURE_DHM4_HIP_X	32.036 in	32.037 in	0.000 in
POSTURE_DHM4_HIP_Z	13.700 in	13.700 in	0.000 in
POSTURE_DHM4_EYE_X	31.608 in	31.608 in	0.000 in
POSTURE_DHM4_EYE_Z	41.380 in	41.380 in	0.000 in
Longest Torso Male			
	UMTRI Value	TARDEC Value	Difference
POSTURE_DHM5_HIP_X	31.280 in	31.280 in	0.000 in
POSTURE_DHM5_HIP_Z	13.694 in	13.694 in	0.000 in
POSTURE_DHM5_EYE_X	31.118 in	31.118 in	0.000 in
POSTURE_DHM5_EYE_Z	42.381 in	42.381 in	0.000 in
Longest Legs Male			
	UMTRI Value	TARDEC Value	Difference
POSTURE_DHM6_HIP_X	33.553 in	33.553 in	0.000 in
POSTURE_DHM6_HIP_Z	13.765 in	13.765 in	0.000 in
POSTURE_DHM6_EYE_X	32.529 in	32.529 in	0.000 in
POSTURE_DHM6_EYE_Z	40.601 in	40.601 in	0.000 in
Large Overall Male			
	UMTRI Value	TARDEC Value	Difference
POSTURE_DHM7_HIP_X	33.378 in	33.378 in	0.000 in
POSTURE_DHM7_HIP_Z	13.862 in	13.862 in	0.000 in
POSTURE_DHM7_EYE_X	32.305 in	32.305 in	0.000 in
POSTURE_DHM7_EYE_Z	42.340 in	42.340 in	0.000 in

TARDEC CAD values to agree with UMTRI spreadsheet values within
 ±0.100 inches
 ±0.100 degrees

Largest Observed Differences:
 0.000 inches

Values in agreement

197

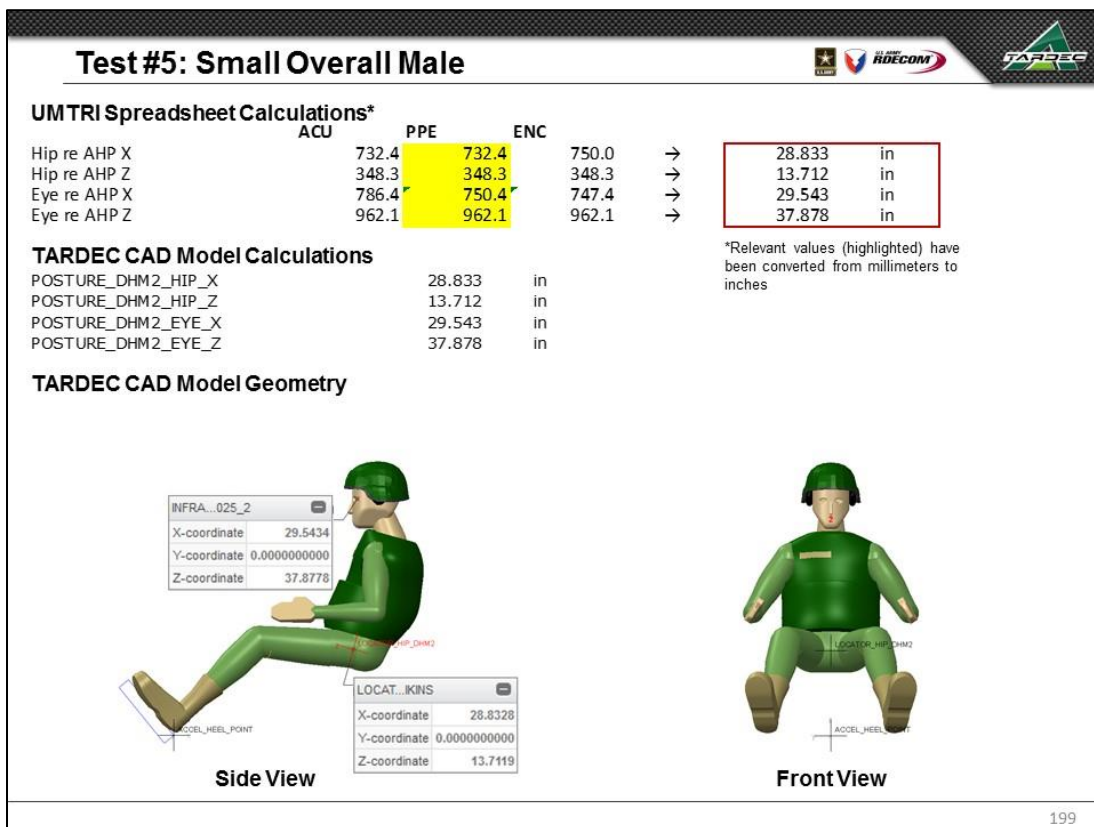
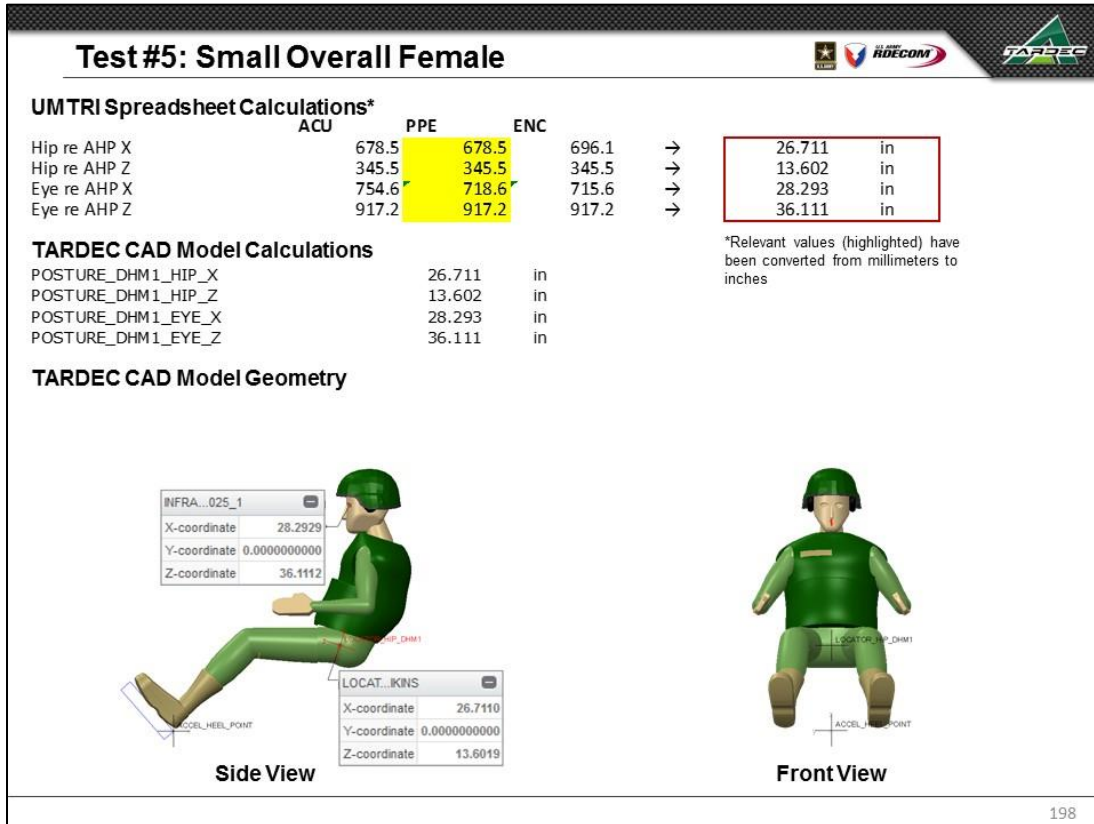

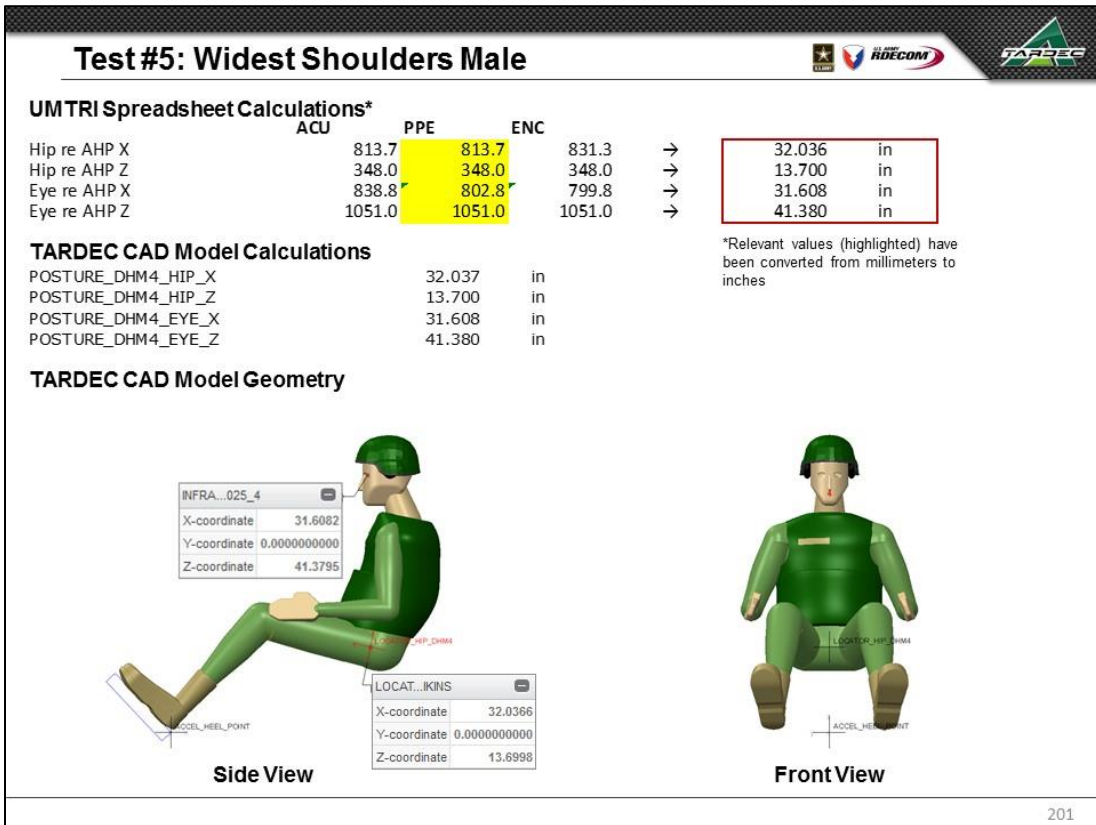
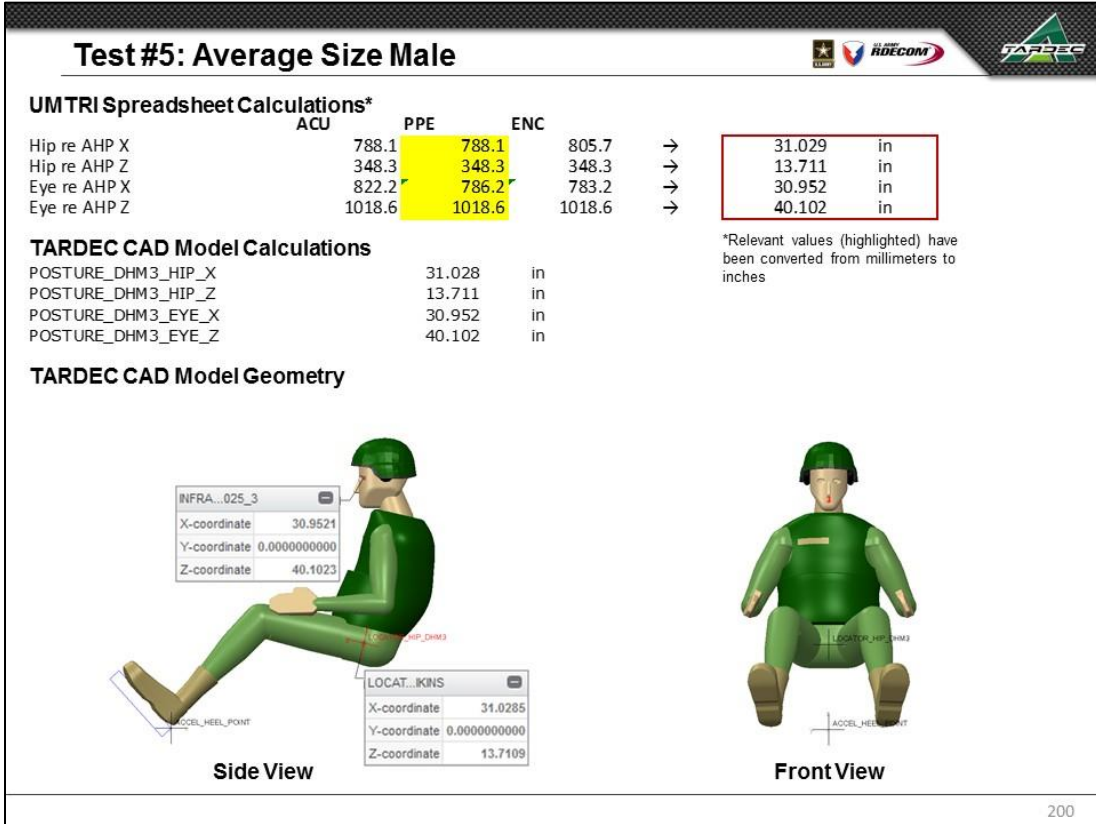

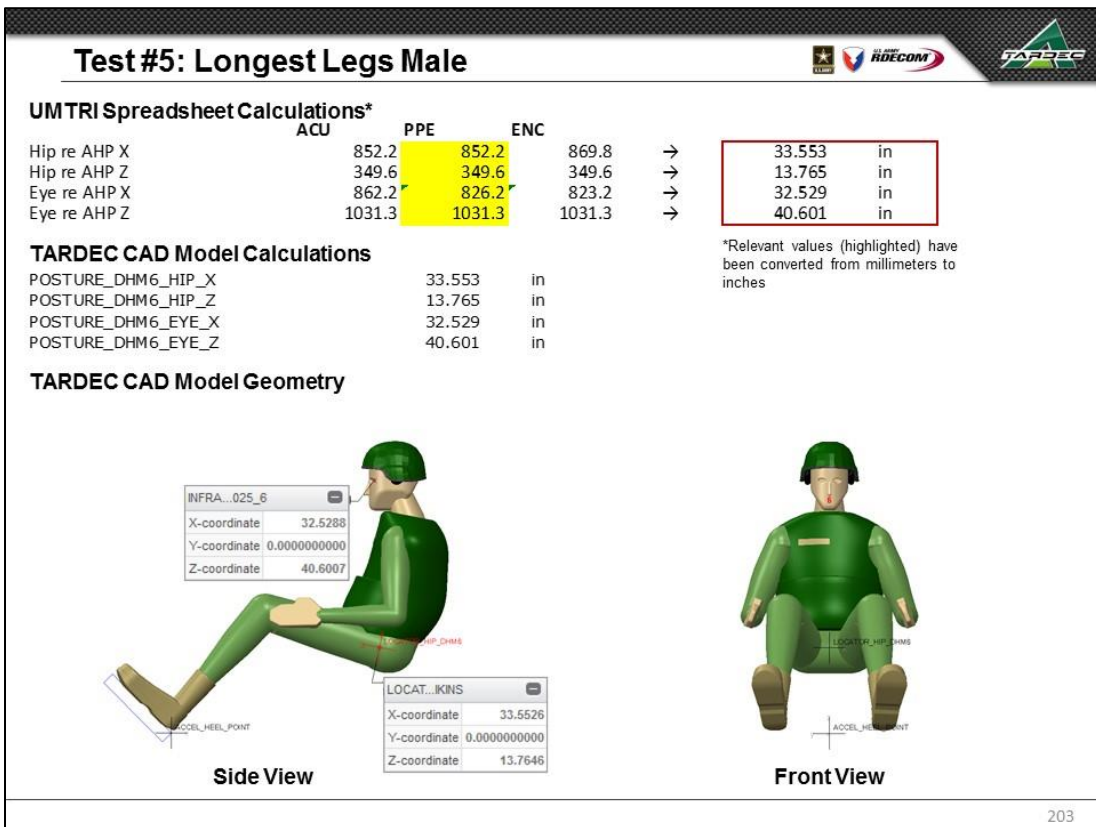
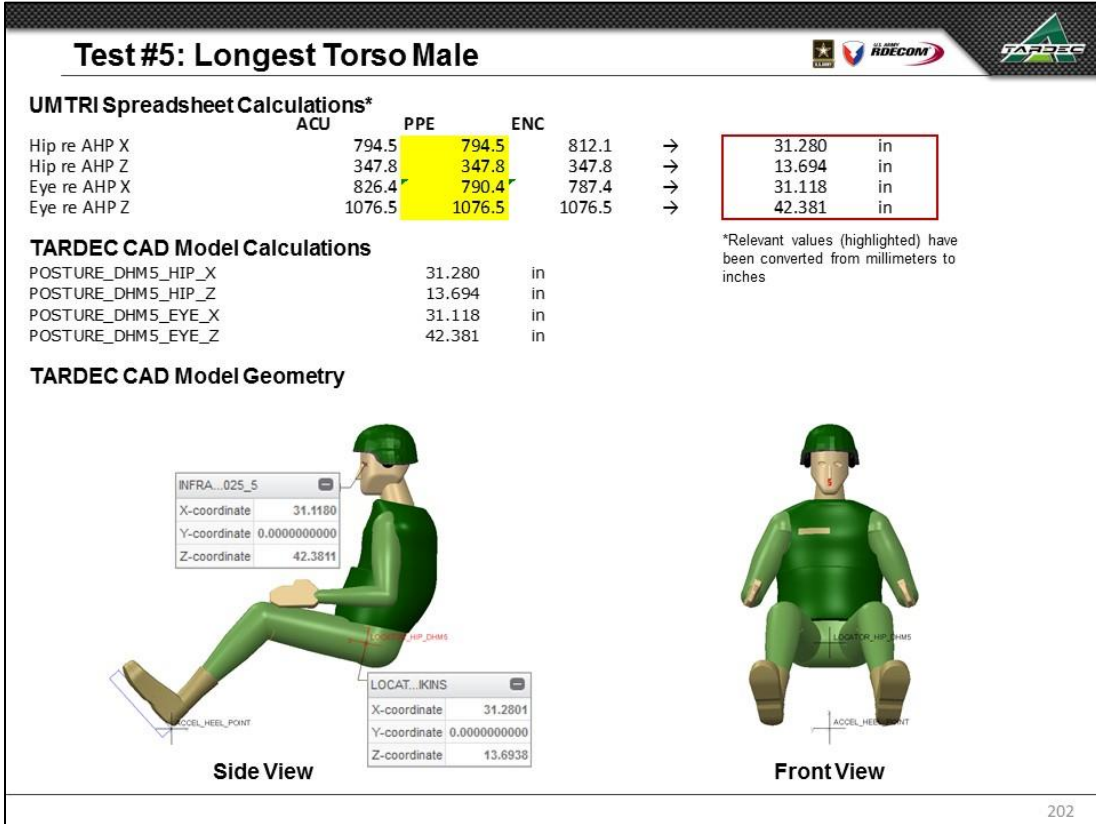

Test #5: Large Overall Male



UMTRI Spreadsheet Calculations*

	ACU	PPE	ENC		
Hip re AHP X	847.8	847.8	865.4	→	33.378 in
Hip re AHP Z	352.1	352.1	352.1	→	13.862 in
Eye re AHP X	856.5	820.5	817.5	→	32.305 in
Eye re AHP Z	1075.4	1075.4	1075.4	→	42.340 in

TARDEC CAD Model Calculations

POSTURE_DHM7_HIP_X	33.378	in
POSTURE_DHM7_HIP_Z	13.862	in
POSTURE_DHM7_EYE_X	32.305	in
POSTURE_DHM7_EYE_Z	42.340	in

TARDEC CAD Model Geometry

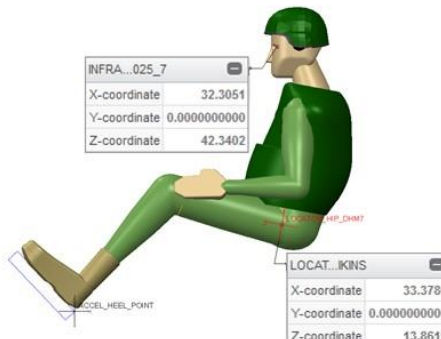

Side View



Front View

*Relevant values (highlighted) have been converted from millimeters to inches

10.7.6 TEST #6 – VARY SWP IN FORE-AFT (X) AND VERTICAL (Z) DIRECTION AND ENSEMBLE

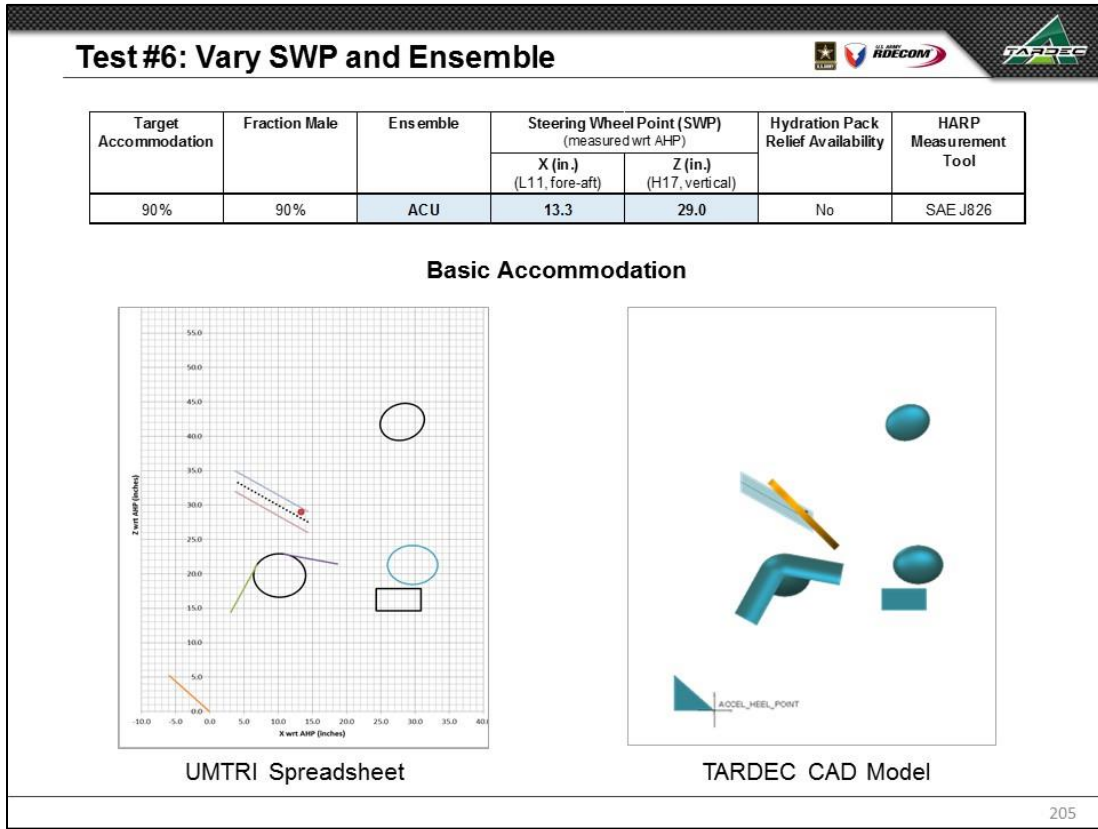

Surrogate Steering Wheel			
	UMTRI Value	TARDEC Value	Difference
STEERING_WHEEL_X	13.300 in	13.300 in	0.000 in
STEERING_WHEEL_Z	29.000 in	29.000 in	0.000 in
Steering Wheel Preference Line			
	UMTRI Value	TARDEC Value	Difference
STRG_WHL_FWD_X	14.297 in	14.297 in	0.000 in
STRG_WHL_FWD_Z	27.559 in	27.559 in	0.000 in
STRG_WHL_RWD_X	3.733 in	3.733 in	0.000 in
STRG_WHL_RWD_Z	33.465 in	33.465 in	0.000 in
Steering Wheel Preference Zone			
	UMTRI Value	TARDEC Value	Difference
STRG_WHL_ZONE_Z	1.518 in	1.518 in	0.001 in
STRG_WHL_ZONE_Y	N/A	1.000 in	N/A
Accelerator Plane Angle (APA)			
	UMTRI Value	TARDEC Value	Difference
ACCEL_PEDAL_PLANE_ANG	41.438 deg	41.438 deg	0.000 deg
Origin (X)	0.000 in	0.000 in	0.000 in
Origin (Z)	0.000 in	0.000 in	0.000 in
BOFRP (X)	-5.903 in	-5.903 in	0.000 in
BOFRP (Z)	5.211 in	5.211 in	0.000 in
Seat Track Travel Range			
	UMTRI Value	TARDEC Value	Difference
SEAT_POSITION_CTR_OF_TRAVEL_X	27.603 in	27.603 in	0.001 in
SEAT_POSITION_CTR_OF_TRAVEL_Z	16.244 in	16.244 in	0.000 in
SEAT_POSITION_FORE_AFT_TRAVEL	6.535 in	6.535 in	0.001 in
SEAT_POSITION_VERTICAL_TRAVEL	3.223 in	3.223 in	0.001 in
Seat Back Angle			
	UMTRI Value	TARDEC Value	Difference
SEAT_BACK_ANGLE_LOWER_QUANTILE	16.510 deg	16.507 deg	0.004 deg
SEAT_BACK_ANGLE_UPPER_QUANTILE	26.708 deg	26.712 deg	0.004 deg
Eyellipse			
	UMTRI Value	TARDEC Value	Difference
EYELLIPSE_CENTROID_X	28.114 in	28.114 in	0.000 in
EYELLIPSE_CENTROID_Y (+/-)	1.280 in	1.280 in	0.000 in
EYELLIPSE_CENTROID_Z	42.090 in	42.090 in	0.000 in
EYELLIPSE_ANGLE_REL_X	18.600 deg	18.600 deg	0.000 deg
EYELLIPSE_X_AXIS_LENGTH	6.570 in	6.573 in	0.003 in
EYELLIPSE_Y_AXIS_LENGTH	1.917 in	1.918 in	0.001 in
EYELLIPSE_Z_AXIS_LENGTH	5.236 in	5.240 in	0.004 in

Helmet Boundary			
The ACU ensemble does not include a helmet			
Knee Boundary			
	UMTRI Value	TARDEC Value	Difference
KNEE_CONTOUR_WEIGHTED_CENT_X	10.199 in	10.199 in	0.000 in
KNEE_CONTOUR_WEIGHTED_CENT_Y (+/-)	7.331 in	7.331 in	0.000 in
KNEE_CONTOUR_WEIGHTED_CENT_Z	19.772 in	19.772 in	0.000 in
KNEE_CONTOUR_X_AXIS_LENGTH	7.611 in	7.613 in	0.002 in
KNEE_CONTOUR_Y_AXIS_LENGTH	8.671 in	8.673 in	0.001 in
KNEE_CONTOUR_Z_AXIS_LENGTH	6.317 in	6.317 in	0.000 in
KNEE_SHOUL_ANGLE	29.013 deg	29.013 deg	0.000 deg
KNEE_THIGH_ANGLE	10.322 deg	10.322 deg	0.000 deg
Torso Boundary			
A torso boundary is not provided when the ACU ensemble is chosen			
Elbow Boundary			
	UMTRI Value	TARDEC Value	Difference
ELBOW_WEIGHTED_CENT_X	29.627 in	29.627 in	0.000 in
ELBOW_WEIGHTED_CENT_Y (+/-)	11.479 in	11.479 in	0.000 in
ELBOW_WEIGHTED_CENT_Z	21.304 in	21.304 in	0.000 in
ELBOW_X_AXIS_LENGTH	7.303 in	7.305 in	0.002 in
ELBOW_Y_AXIS_LENGTH	3.424 in	3.425 in	0.001 in
ELBOW_Z_AXIS_LENGTH	5.665 in	5.668 in	0.003 in

TARDEC CAD values to agree with UMTRI spreadsheet values within
 ±0.100 inches
 ±0.100 degrees

Largest Observed Differences:
 0.004 inches
 0.004 degrees

Values in agreement

206

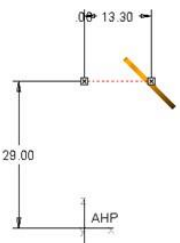
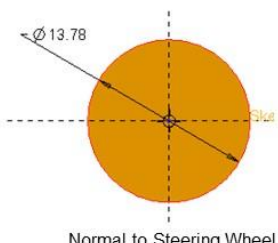
Test #6: Surrogate Steering Wheel			
UMTRI Spreadsheet Calculations			
	L11	H17	
	(in)	(in)	
Steering Wheel Point (SWP)	13.300	29.000	
TARDEC CAD Model Calculations			
STEERING_WHEEL_X	13.300	in	
STEERING_WHEEL_Z	29.000	in	
TARDEC CAD Model Geometry			
 <p>Side View</p>		 <p>Steering Wheel Geometry</p>	

207

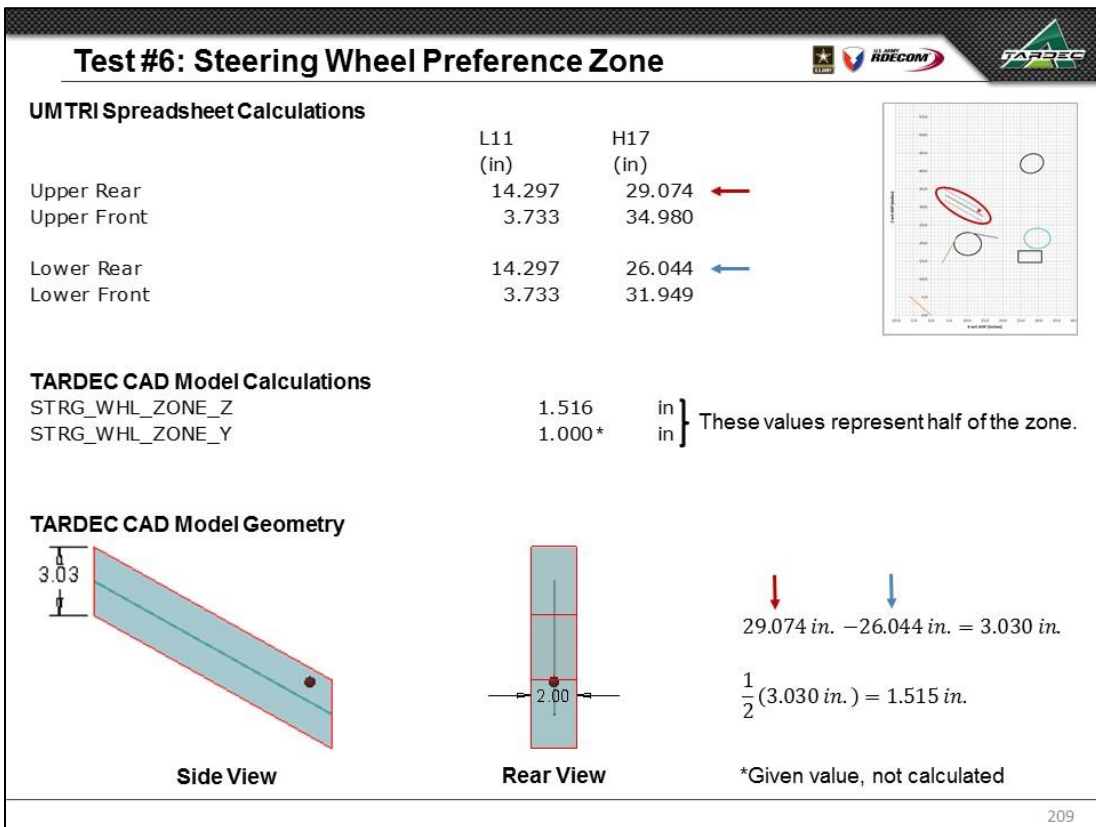
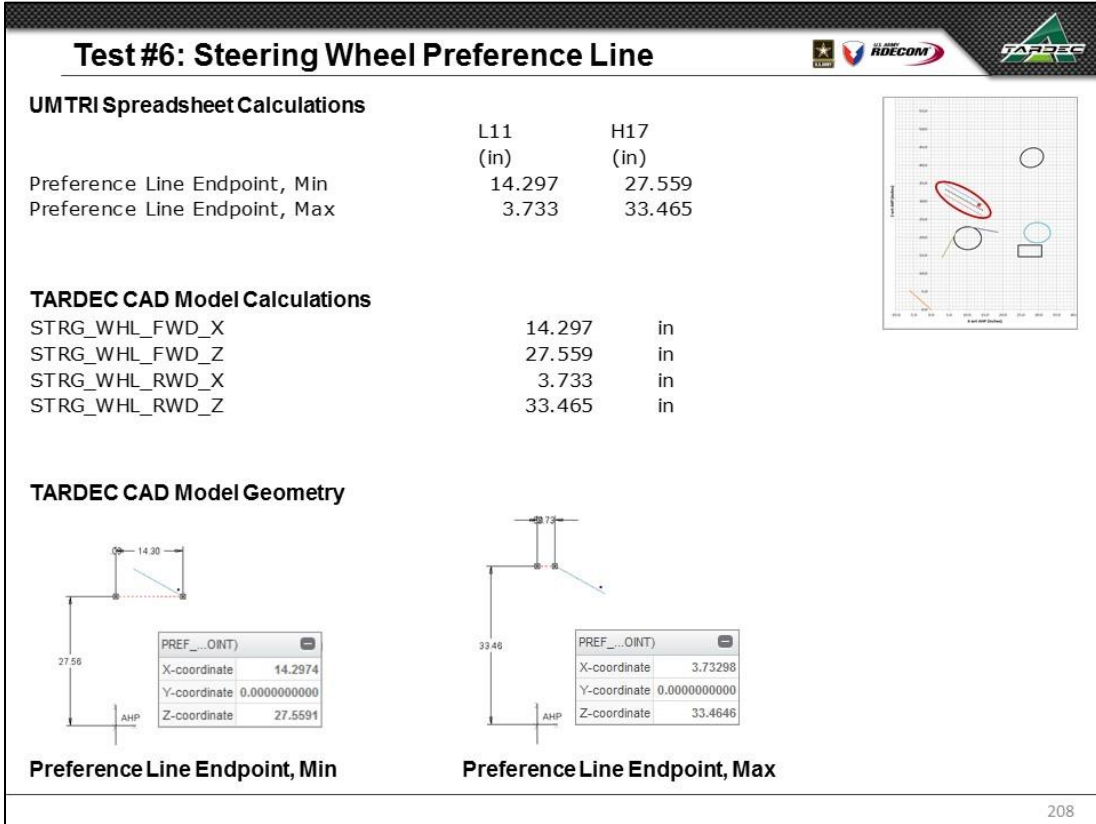

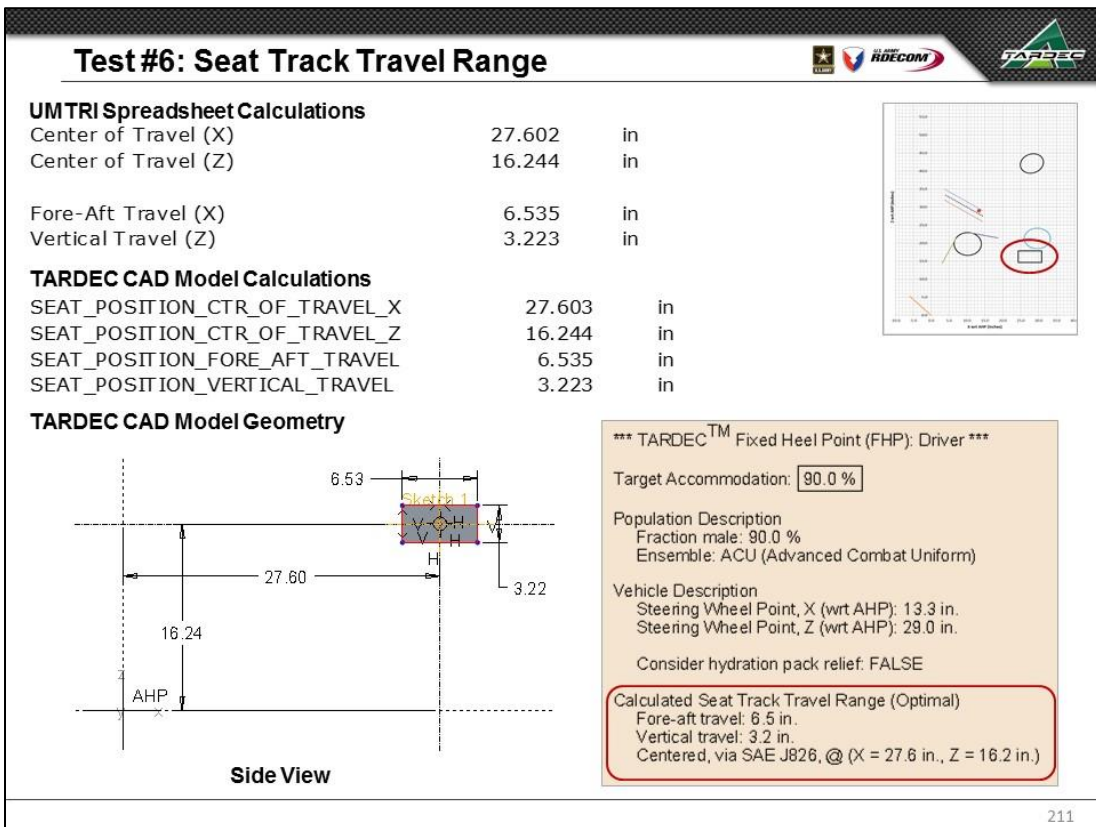
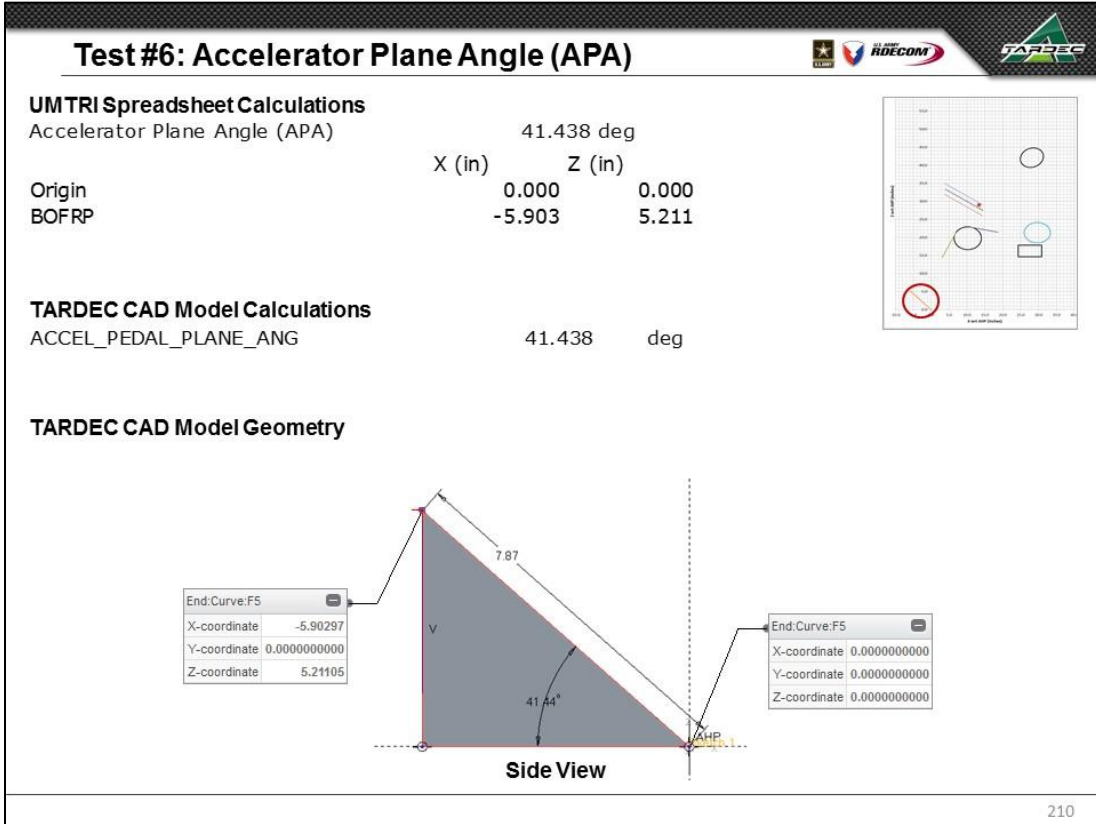

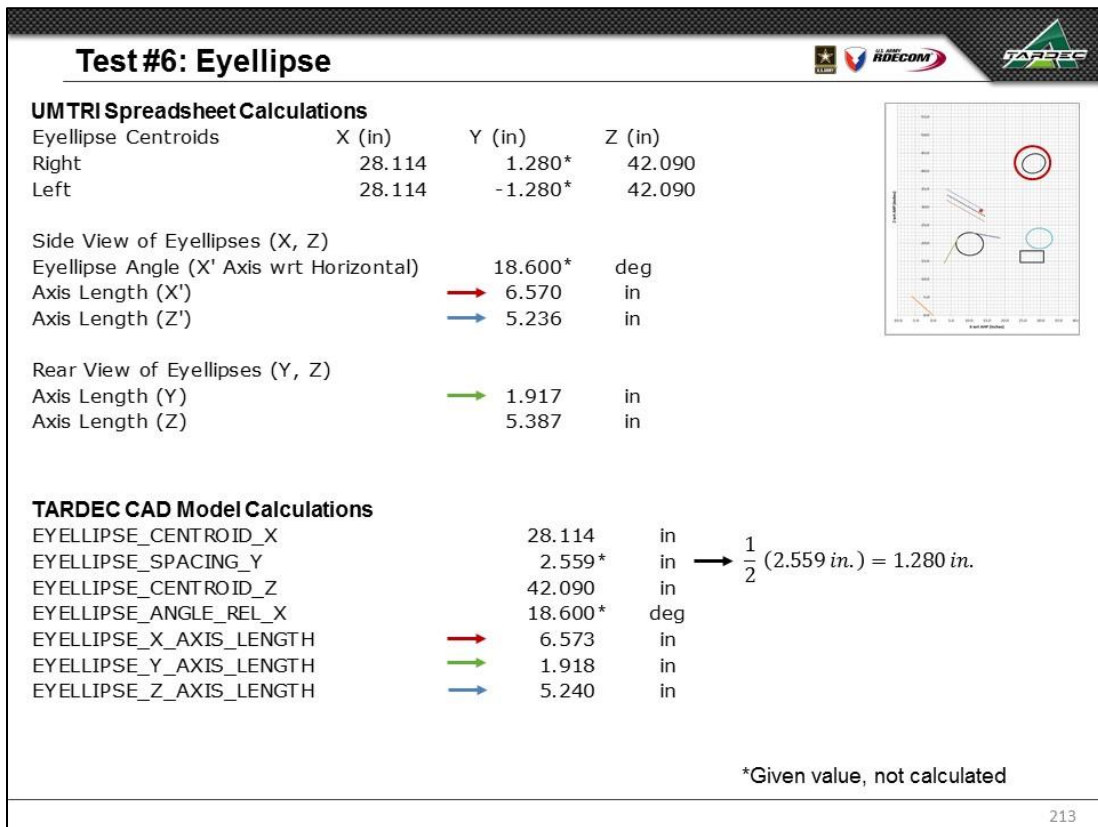
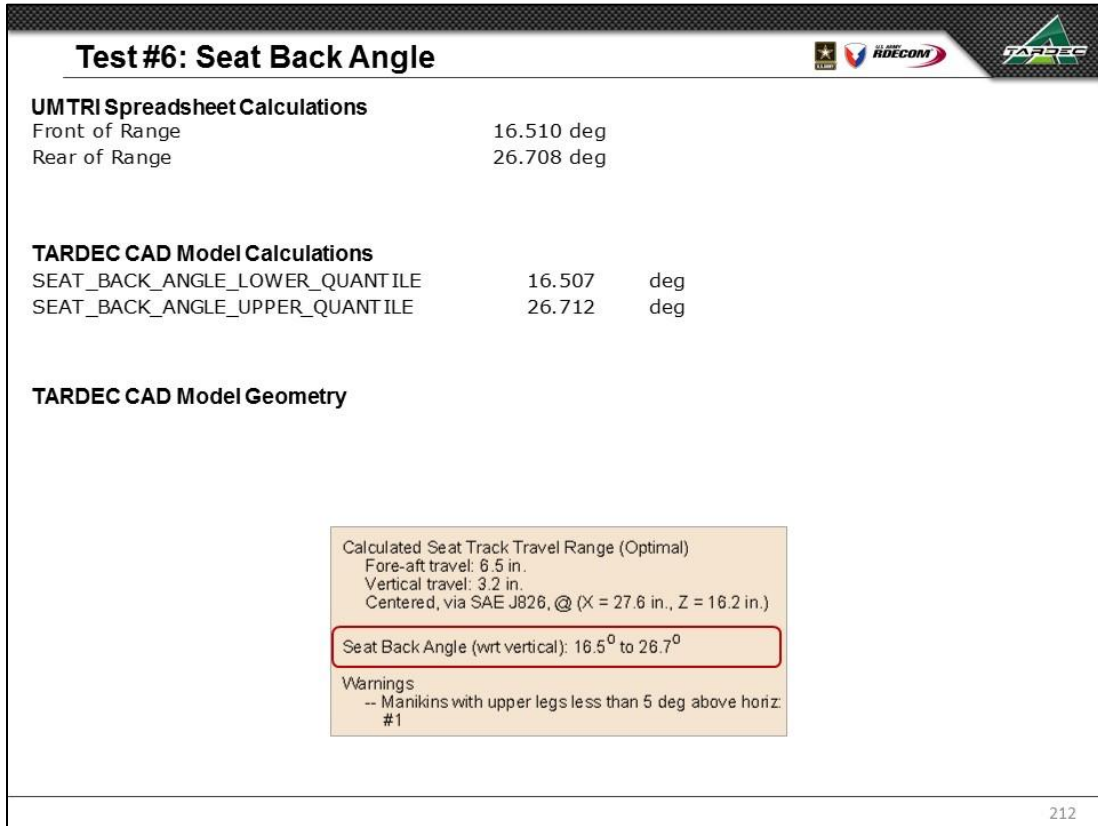

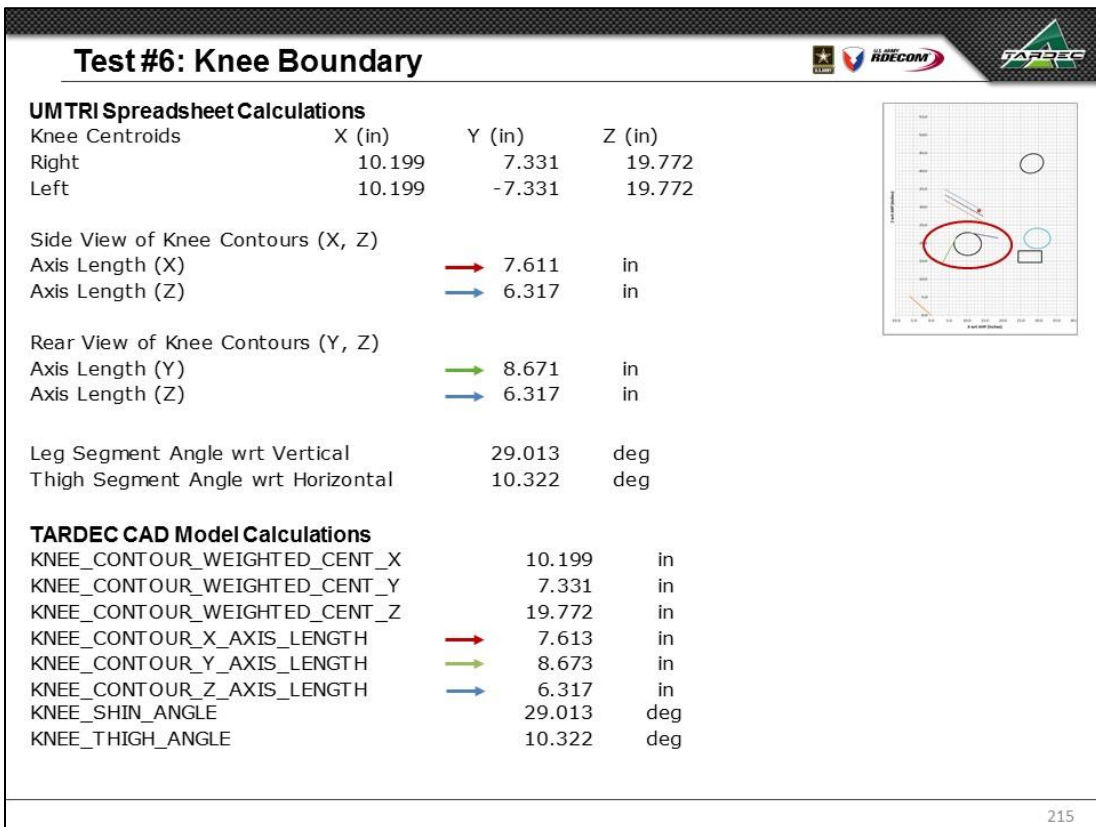
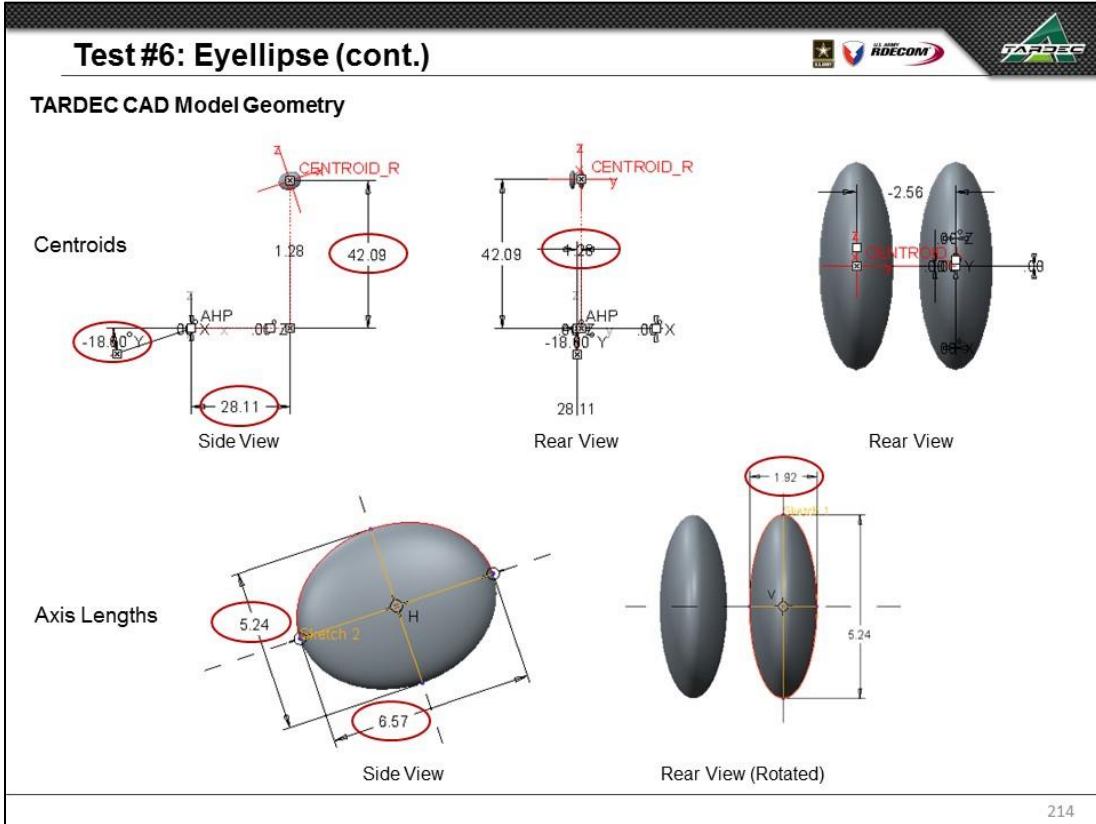

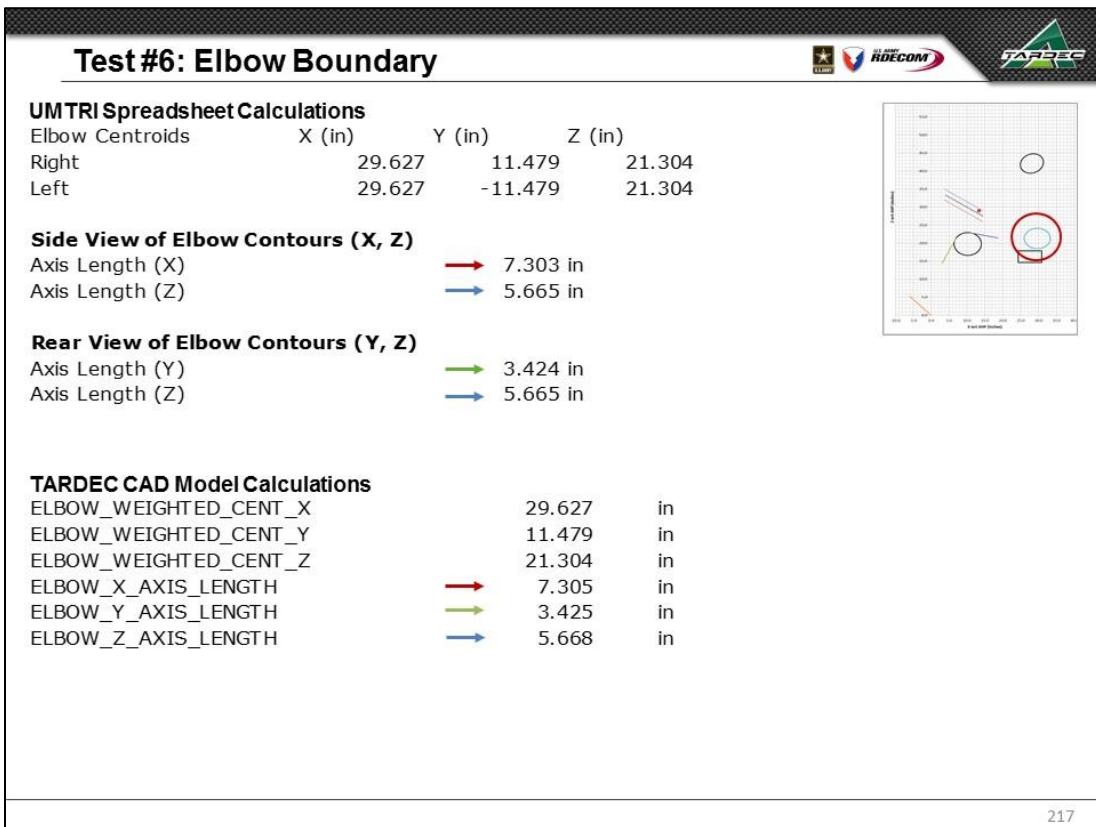
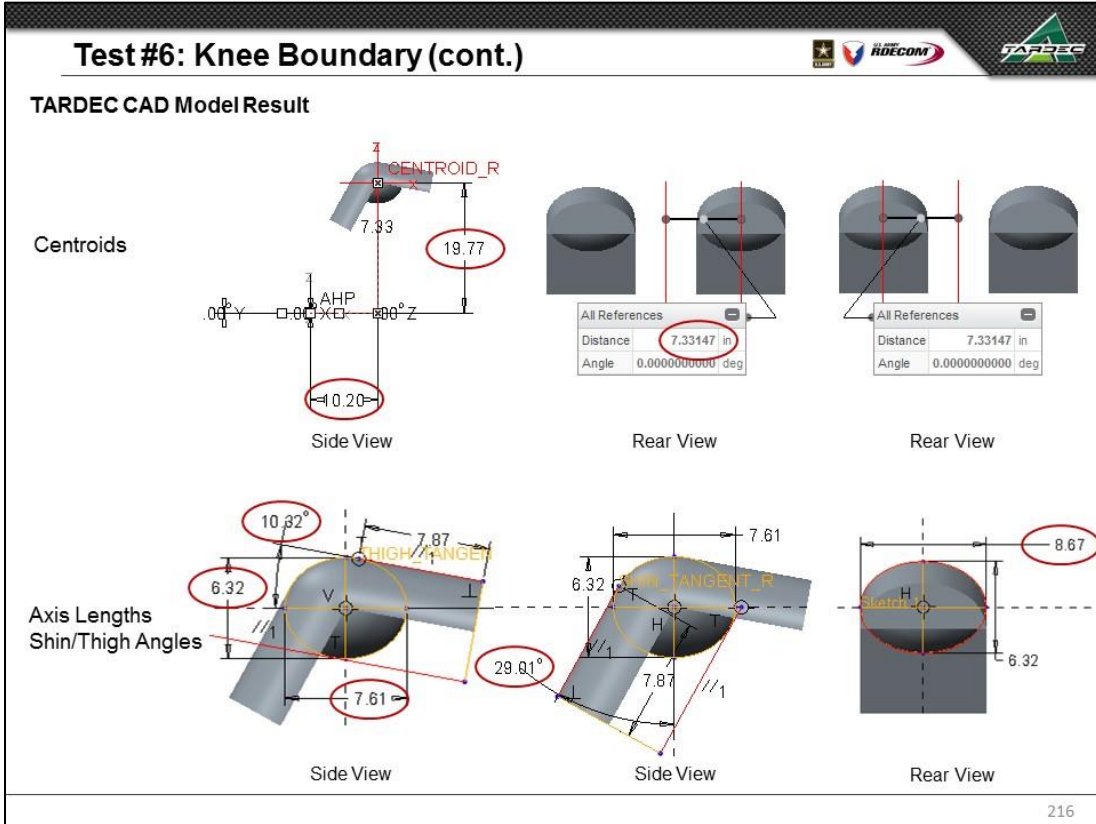

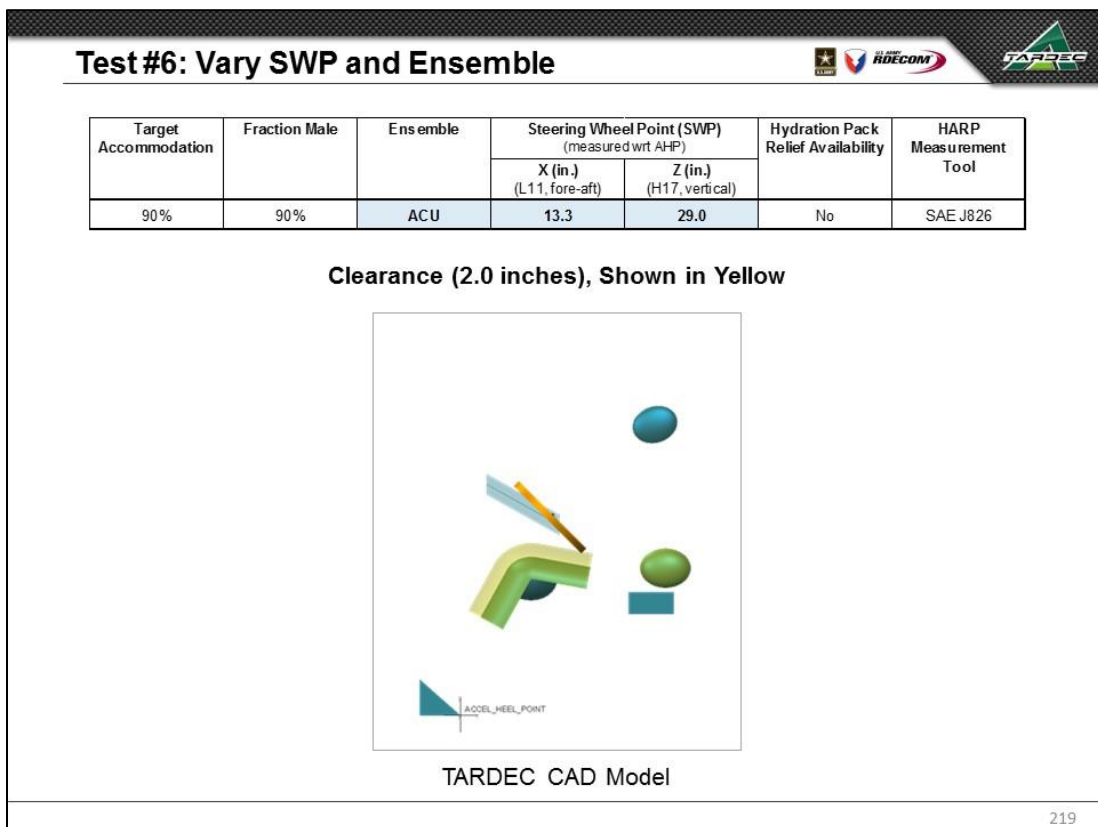
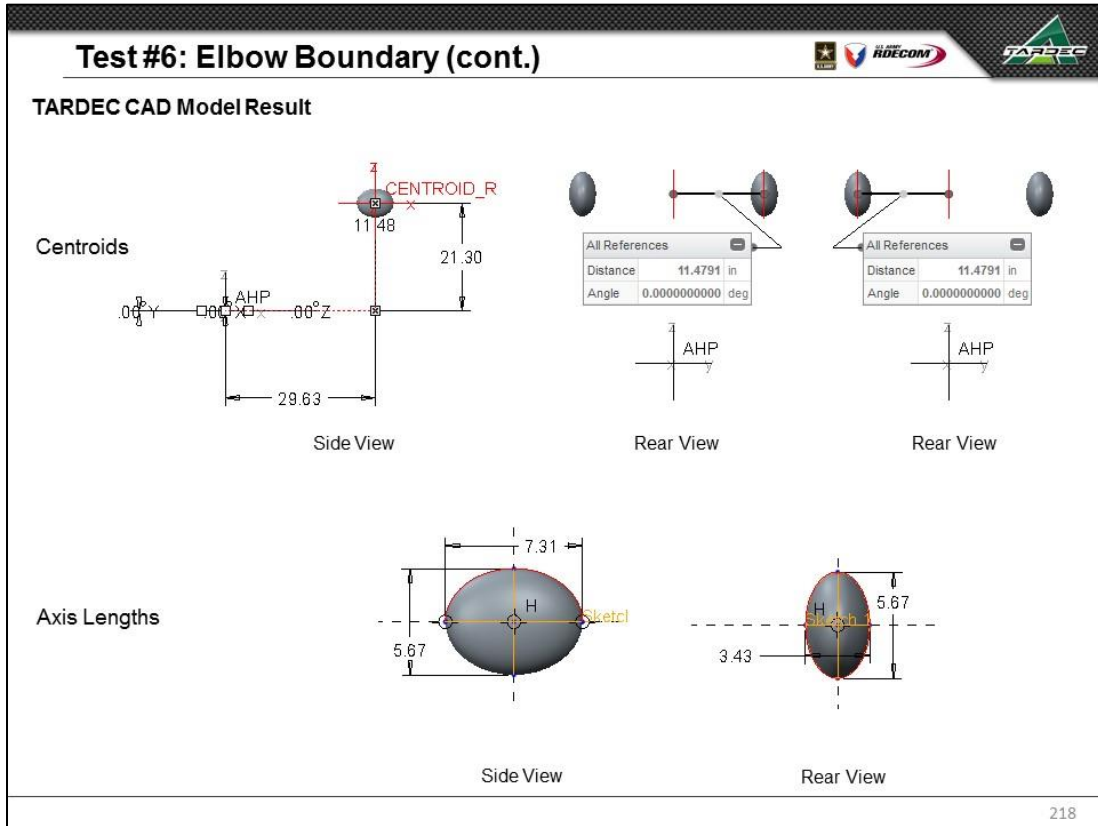

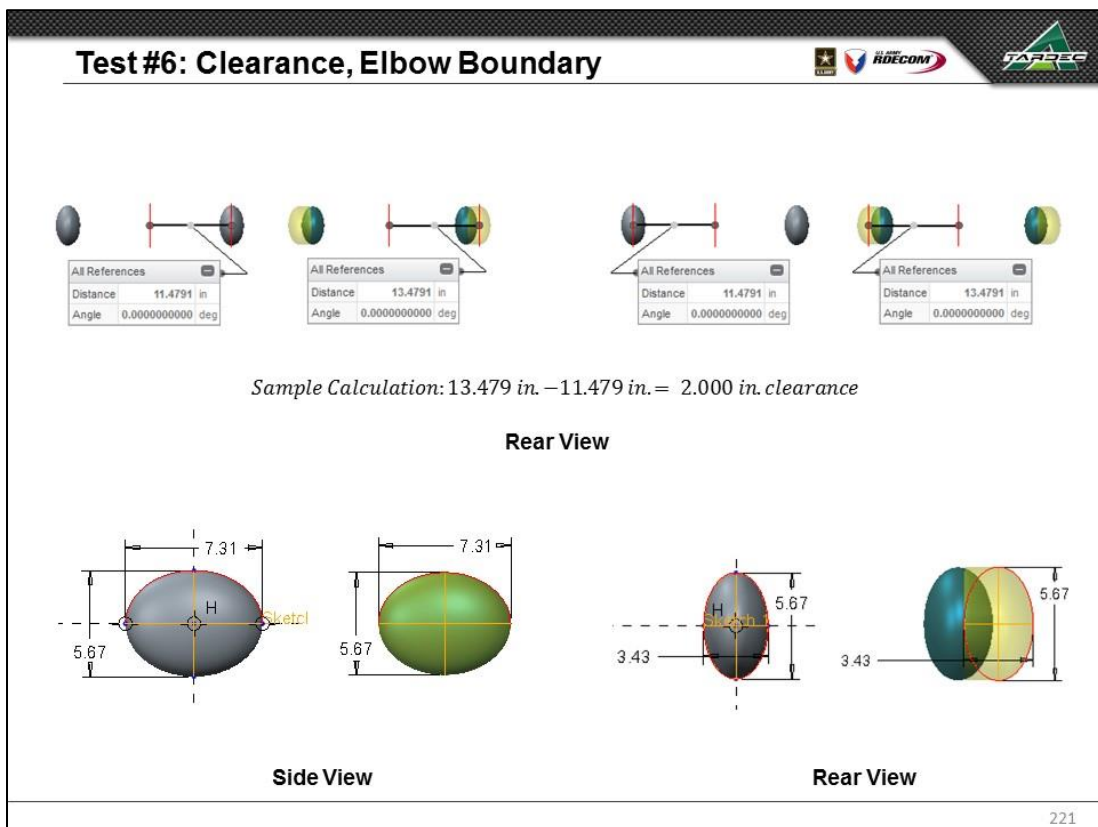
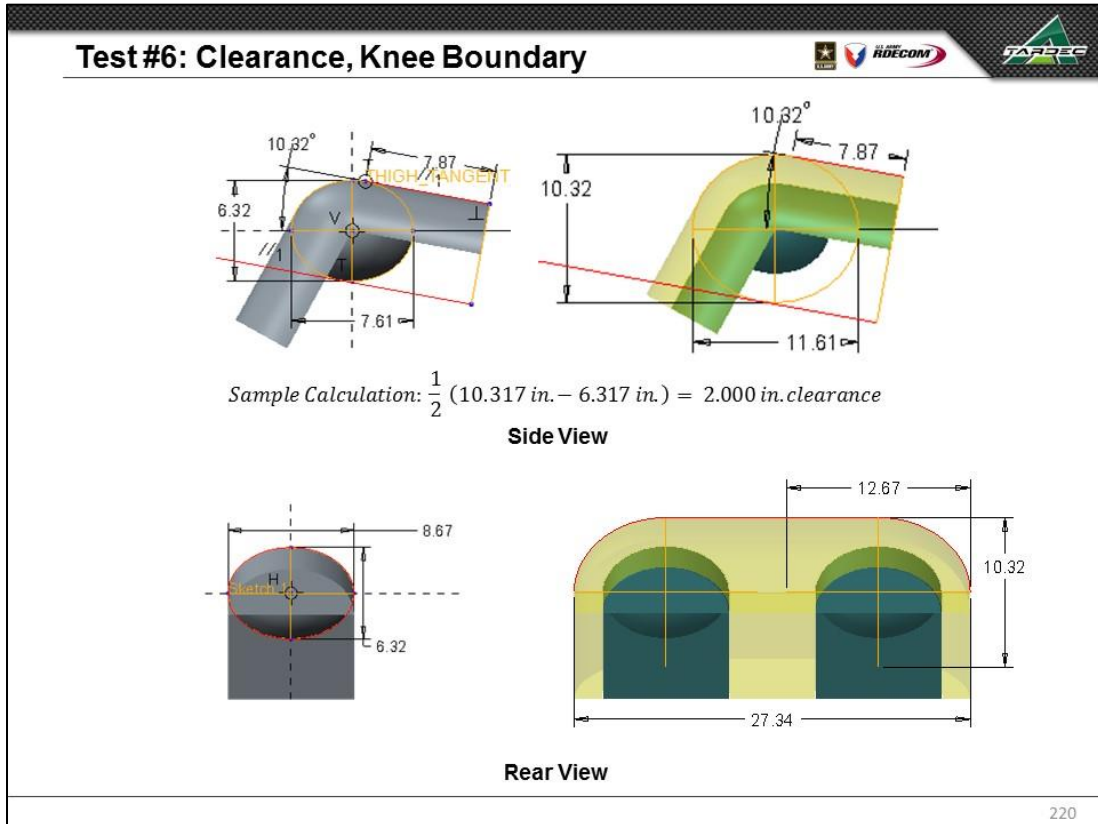

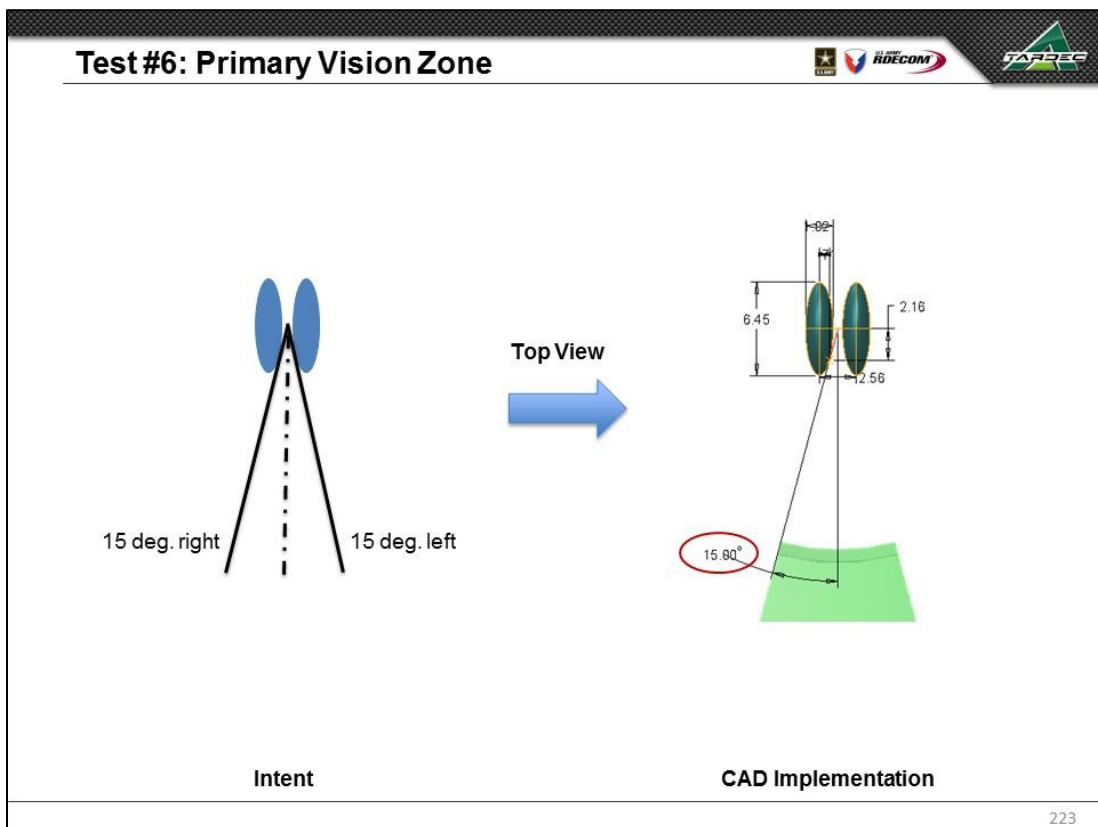
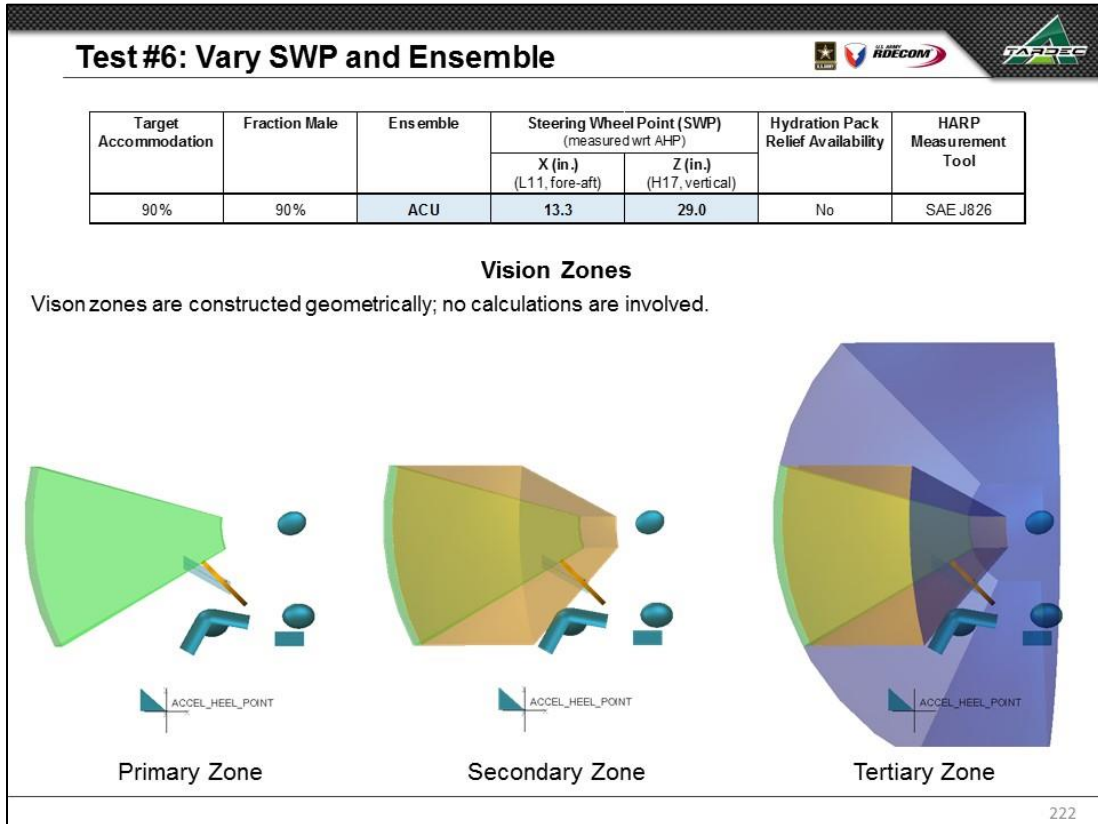

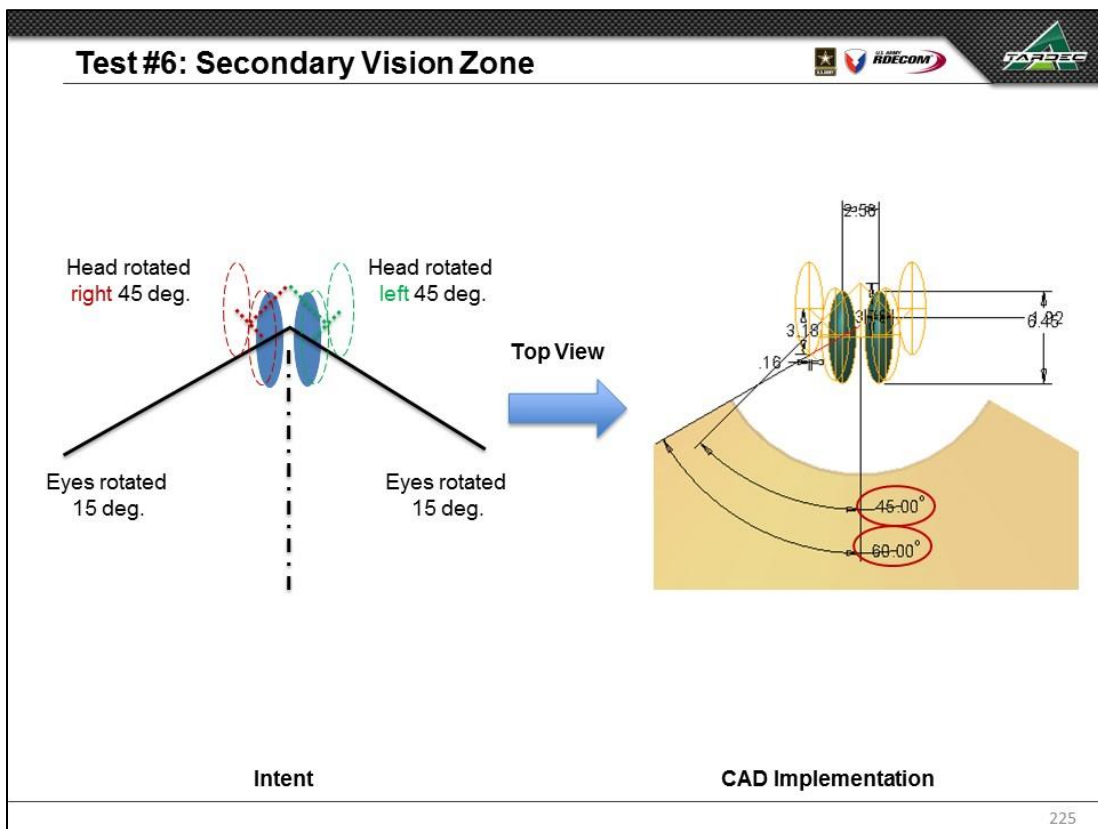
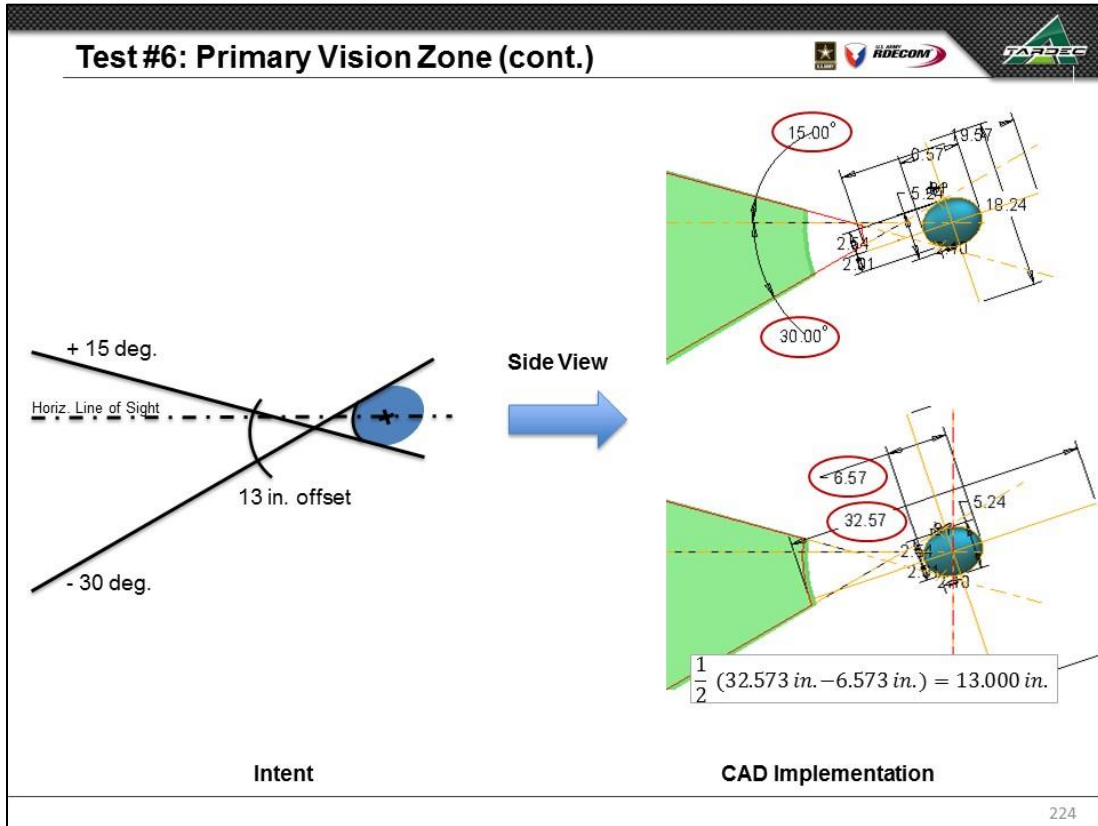

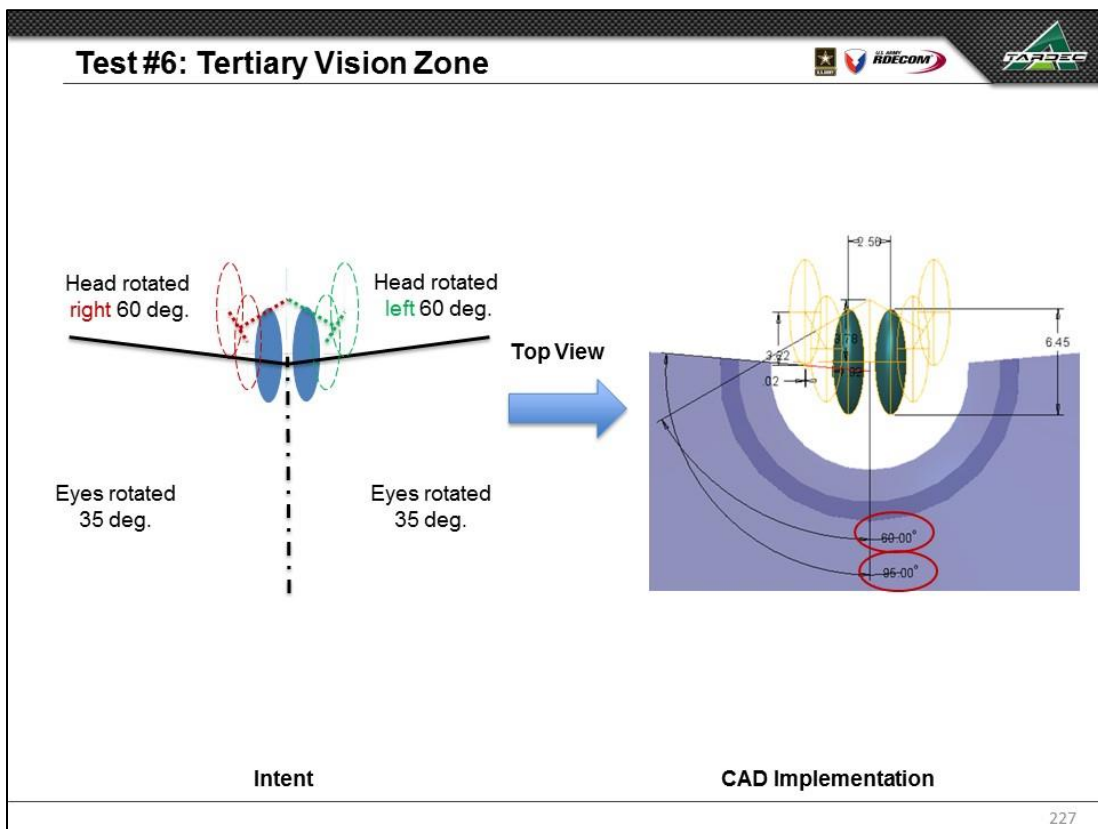
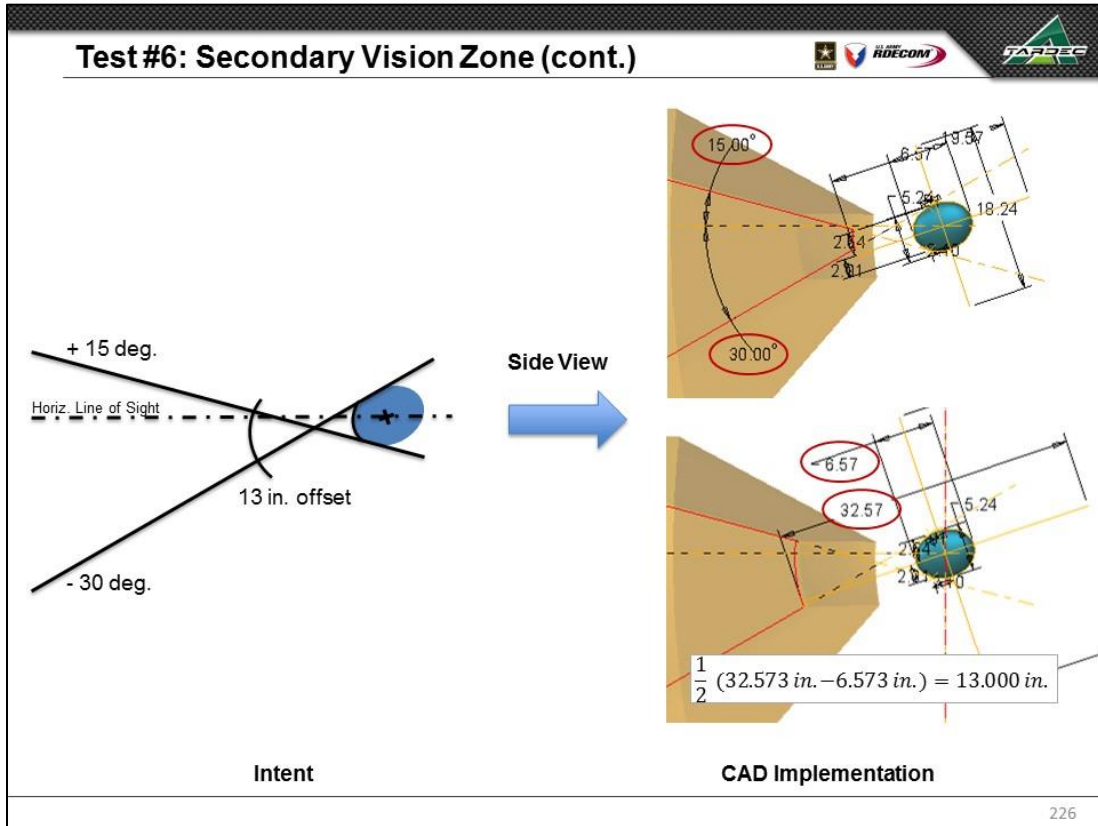

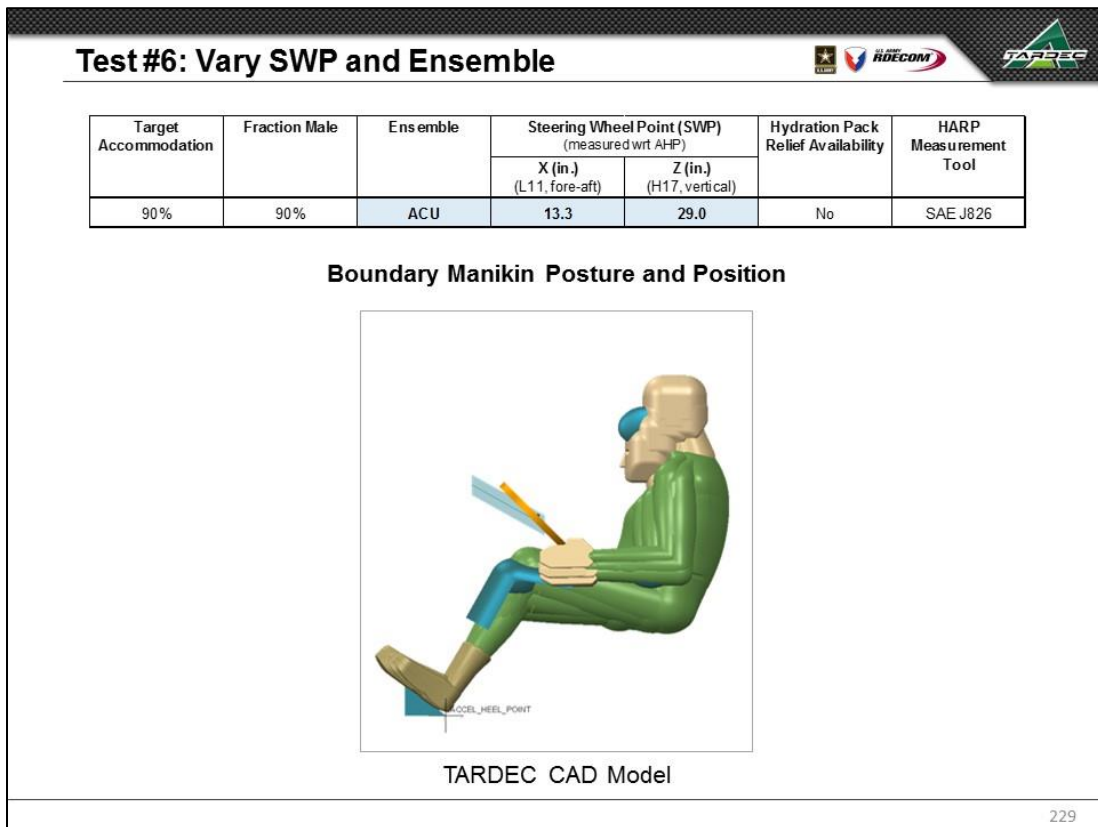
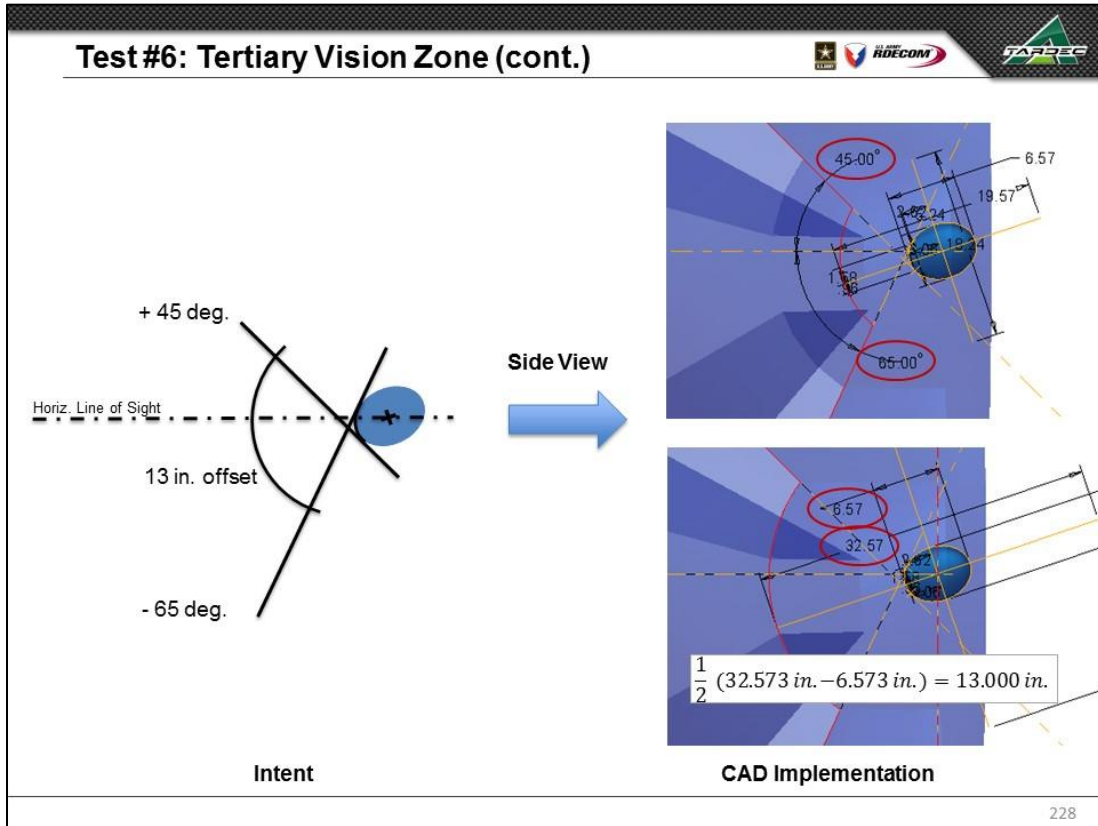

Test #6: Numerical Results, Manikin Positioning

Small Overall Female			
	UMTRI Value	TARDEC Value	Difference
POSTURE_DHM1_HIP_X	23.660 in	23.660 in	0.000 in
POSTURE_DHM1_HIP_Z	15.879 in	15.879 in	0.000 in
POSTURE_DHM1_EYE_X	26.357 in	26.357 in	0.000 in
POSTURE_DHM1_EYE_Z	38.171 in	38.171 in	0.000 in
Small Overall Male			
	UMTRI Value	TARDEC Value	Difference
POSTURE_DHM2_HIP_X	25.782 in	25.782 in	0.000 in
POSTURE_DHM2_HIP_Z	15.989 in	15.989 in	0.000 in
POSTURE_DHM2_EYE_X	27.608 in	27.608 in	0.000 in
POSTURE_DHM2_EYE_Z	39.938 in	39.938 in	0.000 in
Average Size Male			
	UMTRI Value	TARDEC Value	Difference
POSTURE_DHM3_HIP_X	27.977 in	27.977 in	0.000 in
POSTURE_DHM3_HIP_Z	15.988 in	15.988 in	0.000 in
POSTURE_DHM3_EYE_X	29.017 in	29.017 in	0.000 in
POSTURE_DHM3_EYE_Z	42.162 in	42.162 in	0.000 in
Widest Shoulders Male			
	UMTRI Value	TARDEC Value	Difference
POSTURE_DHM4_HIP_X	28.985 in	28.986 in	0.000 in
POSTURE_DHM4_HIP_Z	15.977 in	15.977 in	0.000 in
POSTURE_DHM4_EYE_X	29.673 in	29.673 in	0.000 in
POSTURE_DHM4_EYE_Z	43.440 in	43.440 in	0.000 in
Longest Torso Male			
	UMTRI Value	TARDEC Value	Difference
POSTURE_DHM5_HIP_X	28.229 in	28.229 in	0.000 in
POSTURE_DHM5_HIP_Z	15.971 in	15.971 in	0.000 in
POSTURE_DHM5_EYE_X	29.183 in	29.183 in	0.000 in
POSTURE_DHM5_EYE_Z	44.441 in	44.441 in	0.000 in
Longest Legs Male			
	UMTRI Value	TARDEC Value	Difference
POSTURE_DHM6_HIP_X	30.501 in	30.502 in	0.000 in
POSTURE_DHM6_HIP_Z	16.042 in	16.042 in	0.000 in
POSTURE_DHM6_EYE_X	30.593 in	30.593 in	0.000 in
POSTURE_DHM6_EYE_Z	42.661 in	42.661 in	0.000 in
Large Overall Male			
	UMTRI Value	TARDEC Value	Difference
POSTURE_DHM7_HIP_X	30.327 in	30.327 in	0.000 in
POSTURE_DHM7_HIP_Z	16.139 in	16.139 in	0.000 in
POSTURE_DHM7_EYE_X	30.370 in	30.370 in	0.000 in
POSTURE_DHM7_EYE_Z	44.400 in	44.400 in	0.000 in

TARDEC CAD values to agree with UMTRI spreadsheet values within
 ±0.100 inches
 ±0.100 degrees

Largest Observed Differences:
 0.000 inches

Values in agreement

230

Test #6: Small Overall Female

UMTRI Spreadsheet Calculations*			
	ACU	PPE	ENC
Hip re AHP X	601.0	601.0	618.6
Hip re AHP Z	403.3	403.3	403.3
Eye re AHP X	669.5	633.5	630.5
Eye re AHP Z	969.6	969.6	969.6

23.660	in
15.879	in
26.357	in
38.171	in

*Relevant values (highlighted) have been converted from millimeters to inches

TARDEC CAD Model Calculations			
POSTURE_DHM1_HIP_X	23.660	in	
POSTURE_DHM1_HIP_Z	15.879	in	
POSTURE_DHM1_EYE_X	26.357	in	
POSTURE_DHM1_EYE_Z	38.171	in	

TARDEC CAD Model Geometry

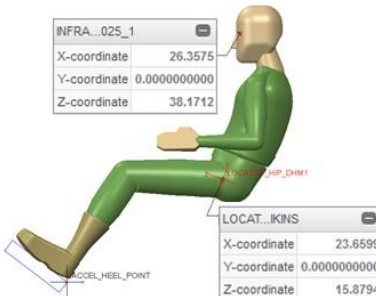

Side View



Front View

231

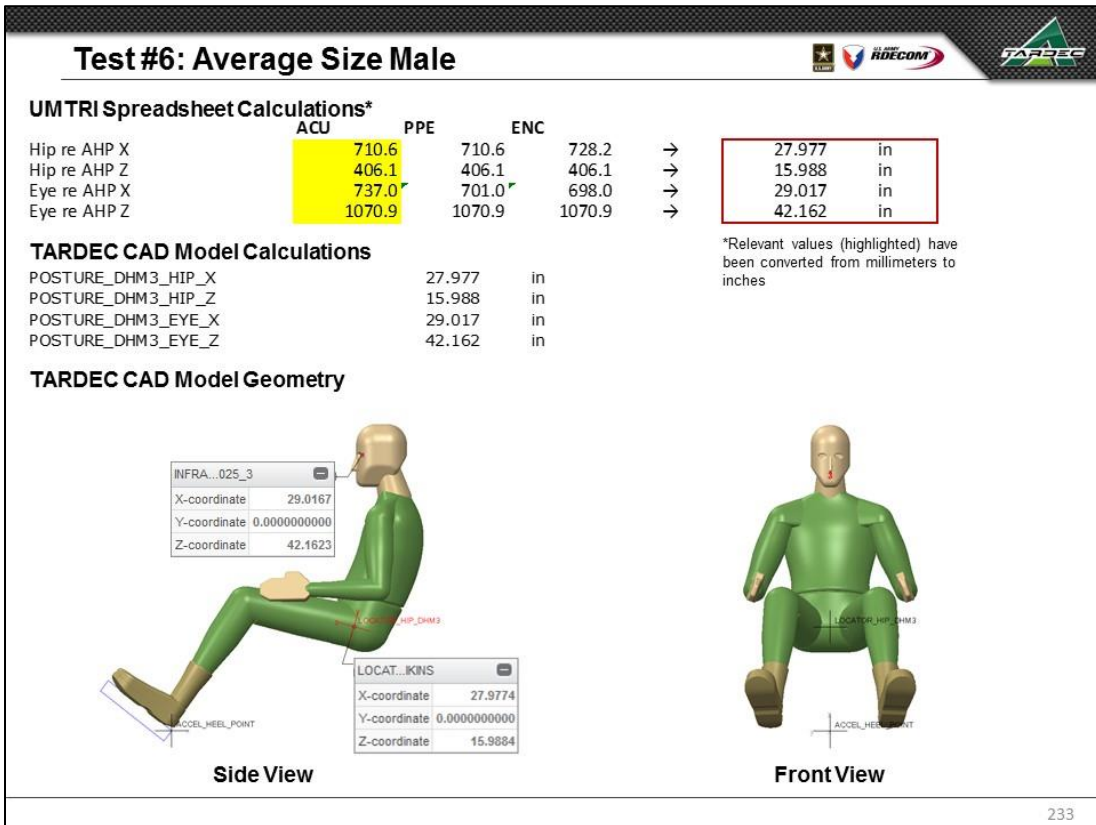
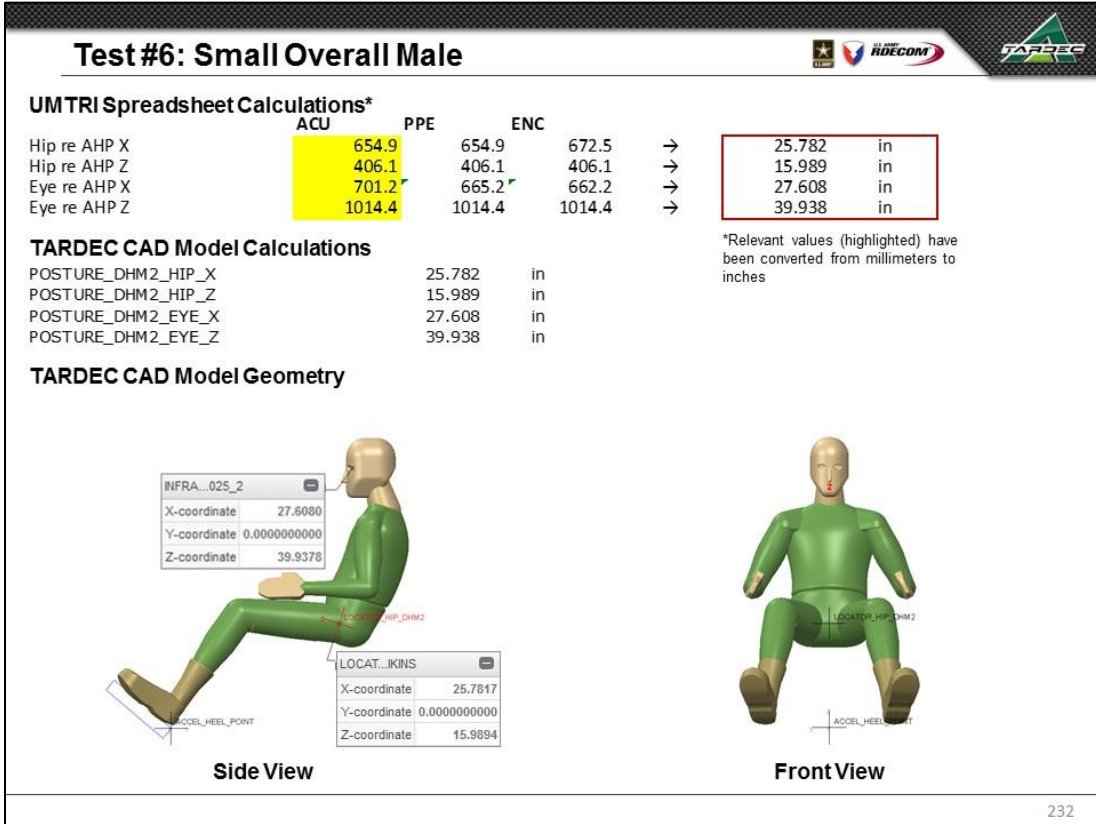

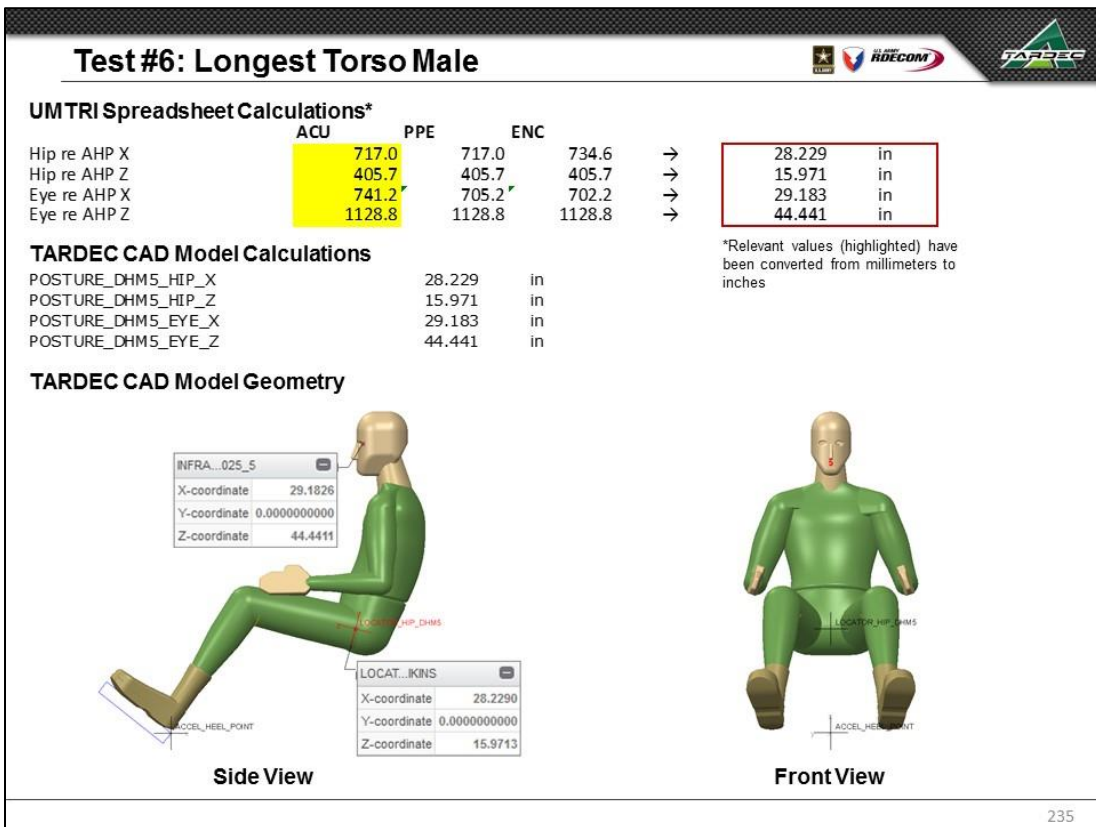
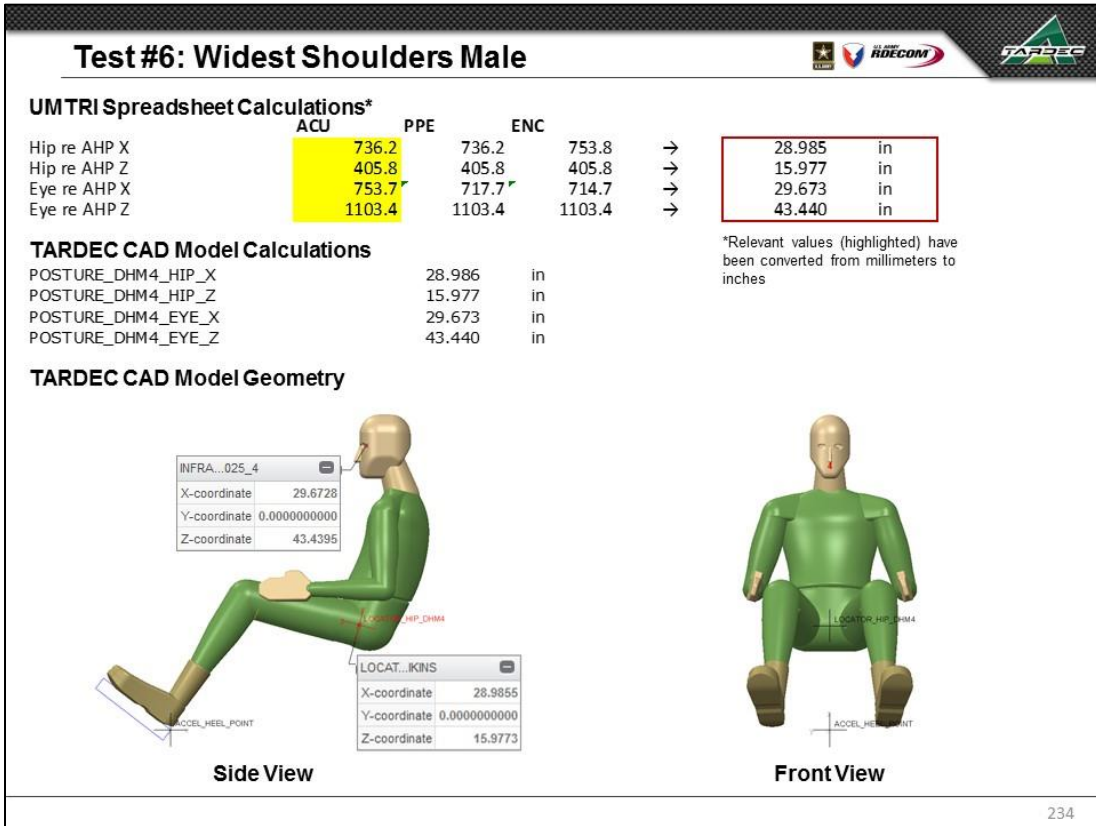

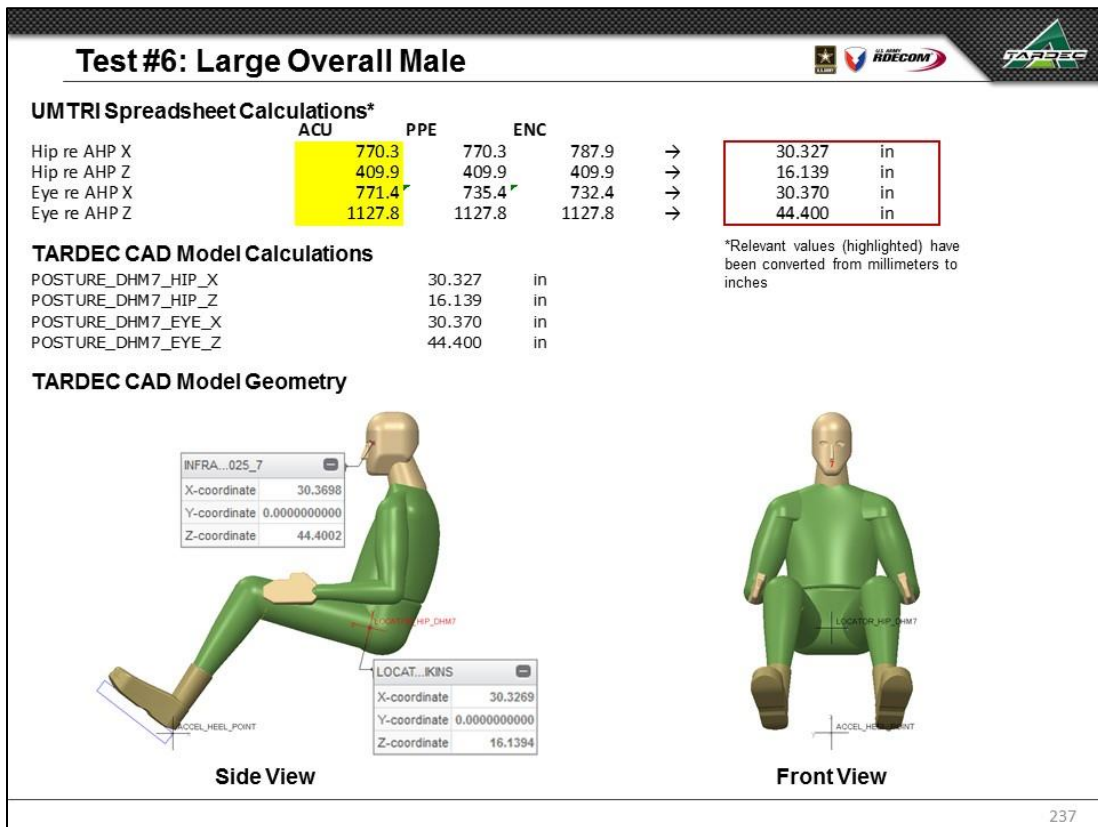
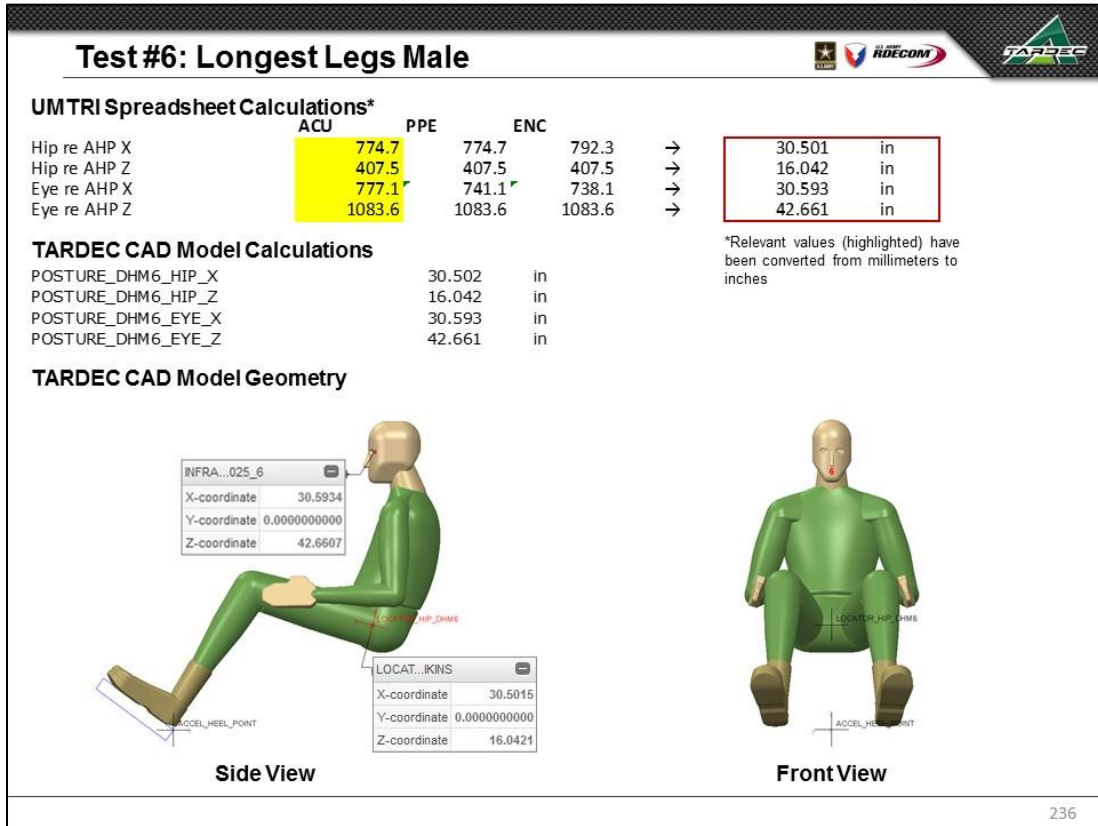

10.7.7 TEST #7 – VARY TARGET ACCOMMODATION AND ENSEMBLE

Test #7: Vary Target Accommodation and Ensemble



Target Accommodation	Fraction Male	Ensemble	Steering Wheel Point (SWP) (measured wrt AHP)		Hydration Pack Relief Availability	HARP Measurement Tool
			X (in.) (L11, fore-aft)	Z (in.) (H17, vertical)		
95%	90%	ENC	13.3	29.0	No	SAE J826

Basic Accommodation

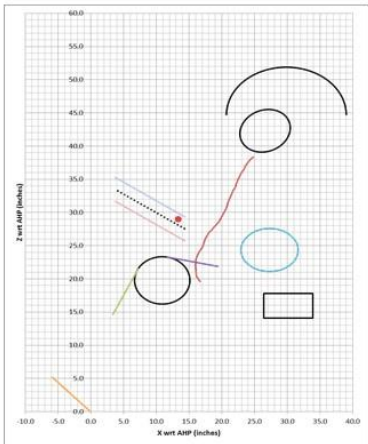



TARDEC CAD Model

238

Test #7: Numerical Results, Accommodation

Surrogate Steering Wheel				Helmet Boundary			
	UMTRI Value	TARDEC Value	Difference		UMTRI Value	TARDEC Value	Difference
STEERING_WHEEL_X	13.300 in	13.300 in	0.000 in	HELMET_CONTOUR_CBTRD_X	29.837 in	29.838 in	0.001 in
STEERING_WHEEL_Z	29.000 in	29.000 in	0.000 in	HELMET_CONTOUR_CBTRD_Y (+/-)	2.185 in	2.185 in	0.000 in
Steering Wheel Preference Line				Knee Boundary			
	UMTRI Value	TARDEC Value	Difference		UMTRI Value	TARDEC Value	Difference
STRG_WHL_FWD_X	14.297 in	14.297 in	0.000 in	KNEE_CONTOUR_WEIGHTED_CENT_X	10.896 in	10.896 in	0.000 in
STRG_WHL_FWD_Z	27.559 in	27.559 in	0.000 in	KNEE_CONTOUR_WEIGHTED_CENT_Y (+/-)	7.331 in	7.331 in	0.000 in
STRG_WHL_RWD_X	3.733 in	3.733 in	0.000 in	KNEE_CONTOUR_WEIGHTED_CENT_Z	19.772 in	19.772 in	0.000 in
STRG_WHL_RWD_Z	33.465 in	33.465 in	0.000 in	KNEE_CONTOUR_X_AXIS_LENGTH	8.436 in	8.435 in	0.001 in
Steering Wheel Preference Zone				Torso Boundary			
	UMTRI Value	TARDEC Value	Difference		UMTRI Value	TARDEC Value	Difference
STRG_WHL_ZONE_Z	1.806 in	1.806 in	0.000 in	TORSO_WEIGHTED_REF_PT_ENC_Z	16.513 in	16.517 in	0.004 in
STRG_WHL_ZONE_Y	N/A	1.000 in	N/A	TORSO_WEIGHTED_REF_PT_ENC_X	27.720 in	27.720 in	0.000 in
Accelerator Plane Angle (APA)				Elbow Boundary			
	UMTRI Value	TARDEC Value	Difference		UMTRI Value	TARDEC Value	Difference
ACCEL_PEDAL_PLANE_ANG	41.438 deg	41.438 deg	0.000 deg	ELBOW_WEIGHTED_CBNT_X	27.276 in	27.276 in	0.000 in
Origin (X)	0.000 in	0.000 in	0.000 in	ELBOW_WEIGHTED_CBNT_Y (+/-)	14.707 in	14.707 in	0.000 in
Origin (Z)	0.000 in	0.000 in	0.000 in	ELBOW_WEIGHTED_CBNT_Z	24.940 in	24.940 in	0.000 in
BOFRP (X)	-5.903 in	-5.903 in	0.000 in	ELBOW_X_AXIS_LENGTH	8.744 in	8.742 in	0.002 in
BOFRP (Z)	5.211 in	5.211 in	0.000 in	ELBOW_Y_AXIS_LENGTH	4.102 in	4.101 in	0.001 in
Seat Track Travel Range				Elbow Z Axis Length			
	UMTRI Value	TARDEC Value	Difference		UMTRI Value	TARDEC Value	Difference
SEAT_POSITION_CTR_OF_TRAVEL_X	30.119 in	30.121 in	0.002 in	ELBOW_Z_AXIS_LENGTH	6.486 in	6.488 in	0.001 in
SEAT_POSITION_CTR_OF_TRAVEL_Z	15.949 in	15.949 in	0.000 in	Seat Back Angle			
SEAT_POSITION_FORE_AFT_TRAVEL	7.515 in	7.506 in	0.008 in		UMTRI Value	TARDEC Value	Difference
SEAT_POSITION_VERTICAL_TRAVEL	3.698 in	3.695 in	0.004 in	SEAT_BACK_ANGLE_LOWER_QUANTILE	18.133 deg	18.132 deg	0.001 deg
Seat Back Angle				SEAT_BACK_ANGLE_UPPER_QUANTILE	30.285 deg	30.287 deg	0.001 deg
	UMTRI Value	TARDEC Value	Difference	Eyellipse			
EYELLIPSE_CENTROID_X	26.593 in	26.594 in	0.001 in		UMTRI Value	TARDEC Value	Difference
EYELLIPSE_CENTROID_Y (+/-)	1.280 in	1.280 in	0.000 in	EYELLIPSE_CENTROID_Y (+/-)	1.280 in	1.280 in	0.000 in
EYELLIPSE_CENTROID_Z	42.304 in	42.304 in	0.000 in	EYELLIPSE_CENTROID_Z	42.304 in	42.304 in	0.000 in
EYELLIPSE_ANGLE_REL_X	18.600 deg	18.600 deg	0.000 deg	EYELLIPSE_ANGLE_REL_X	18.600 deg	18.600 deg	0.000 deg
EYELLIPSE_X_AXIS_LENGTH	7.832 in	7.833 in	0.001 in	EYELLIPSE_X_AXIS_LENGTH	7.832 in	7.833 in	0.001 in
EYELLIPSE_Y_AXIS_LENGTH	2.284 in	2.285 in	0.001 in	EYELLIPSE_Y_AXIS_LENGTH	2.284 in	2.285 in	0.001 in
EYELLIPSE_Z_AXIS_LENGTH	6.243 in	6.244 in	0.001 in	EYELLIPSE_Z_AXIS_LENGTH	6.243 in	6.244 in	0.001 in

TARDEC CAD values to agree with UMTRI spreadsheet values within
 ±0.100 inches
 ±0.100 degrees

Largest Observed Differences:
 0.008 inches
 0.001 degrees

Values in agreement

239

Test #7: Surrogate Steering Wheel

UMTRI Spreadsheet Calculations

	L11	H17
	(in)	(in)
Steering Wheel Point (SWP)	13.300	29.000

TARDEC CAD Model Calculations

STEERING_WHEEL_X	13.300	in
STEERING_WHEEL_Z	29.000	in

TARDEC CAD Model Geometry

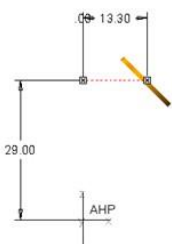

Side View

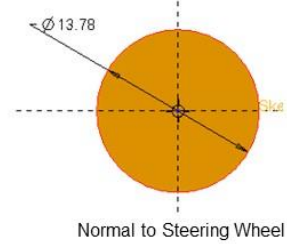

Steering Wheel Geometry

240

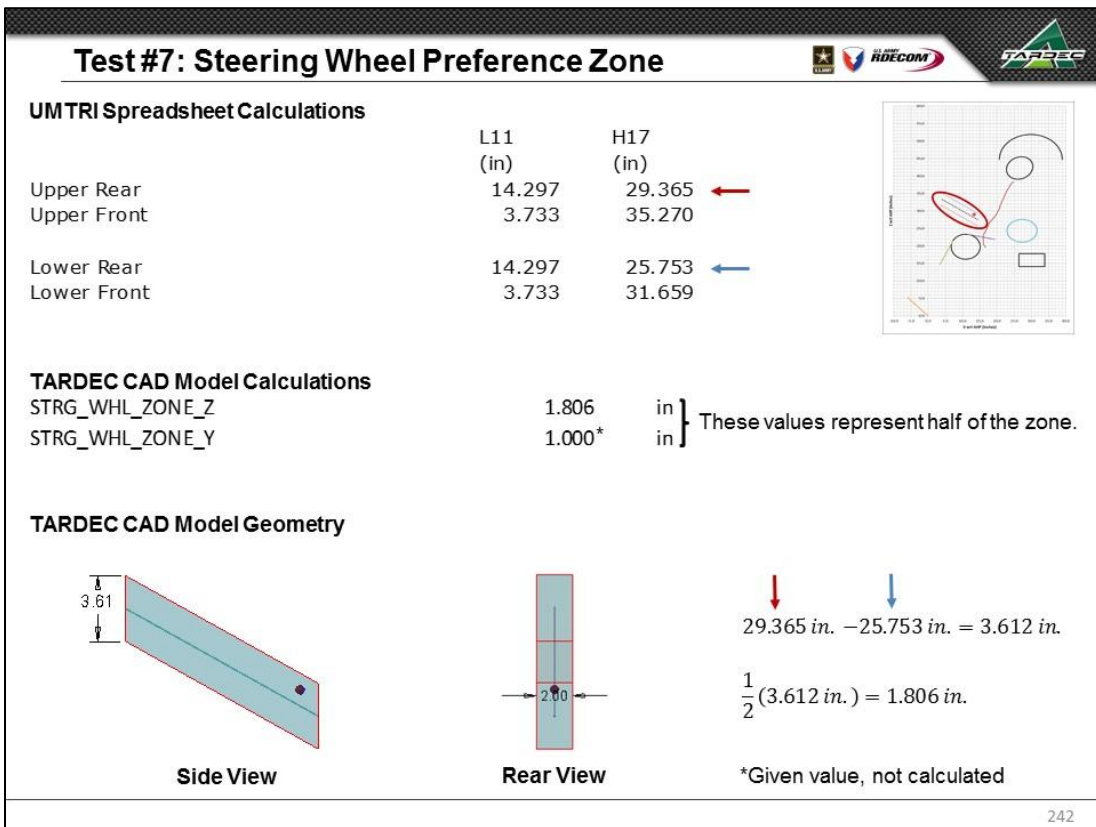
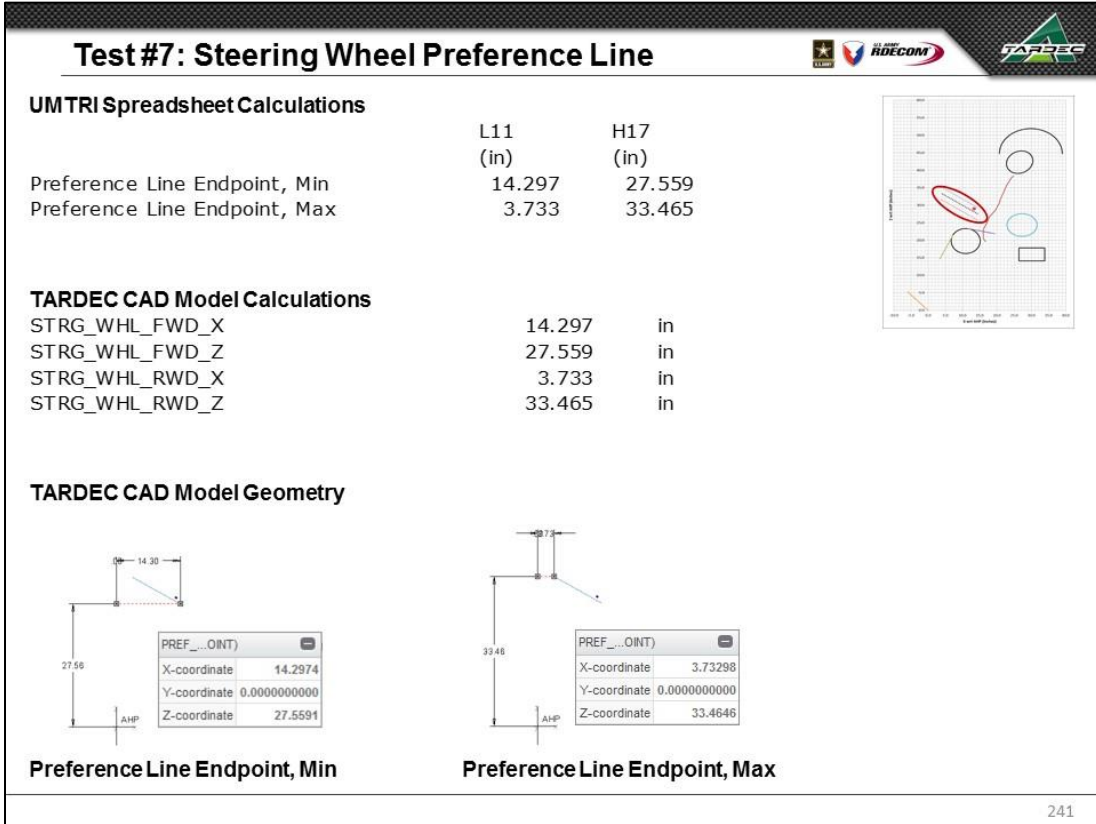

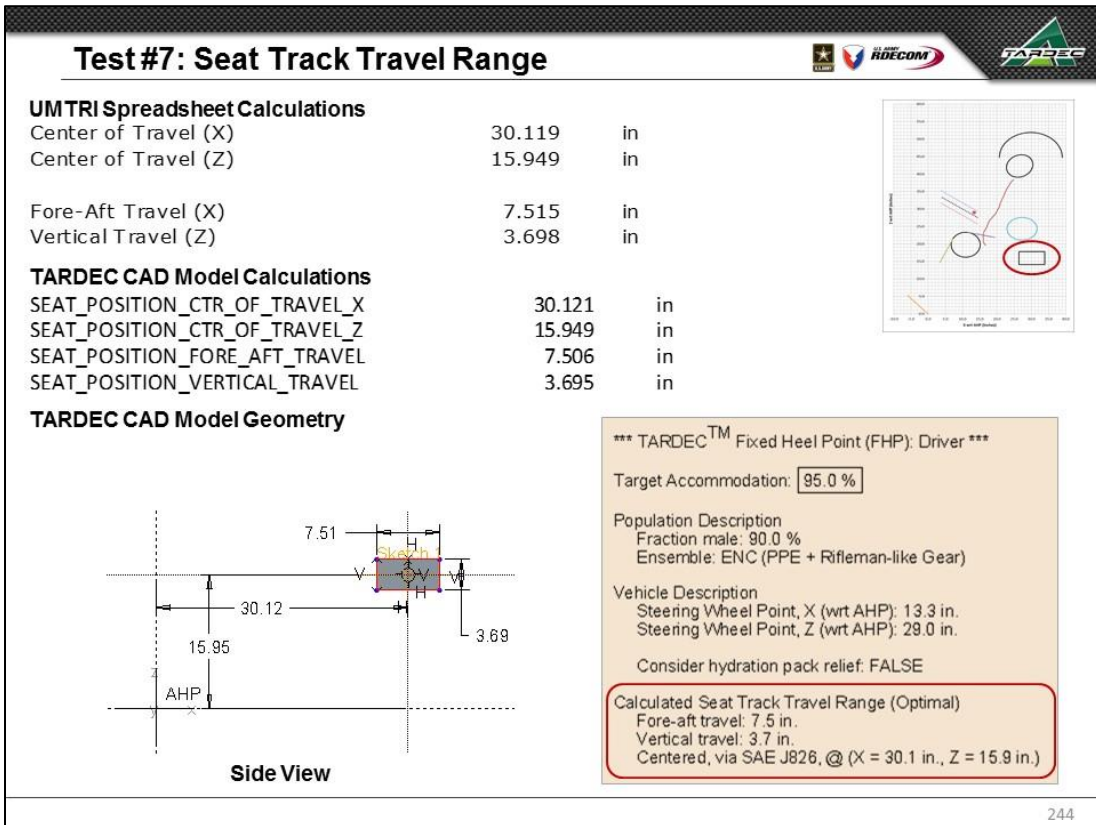
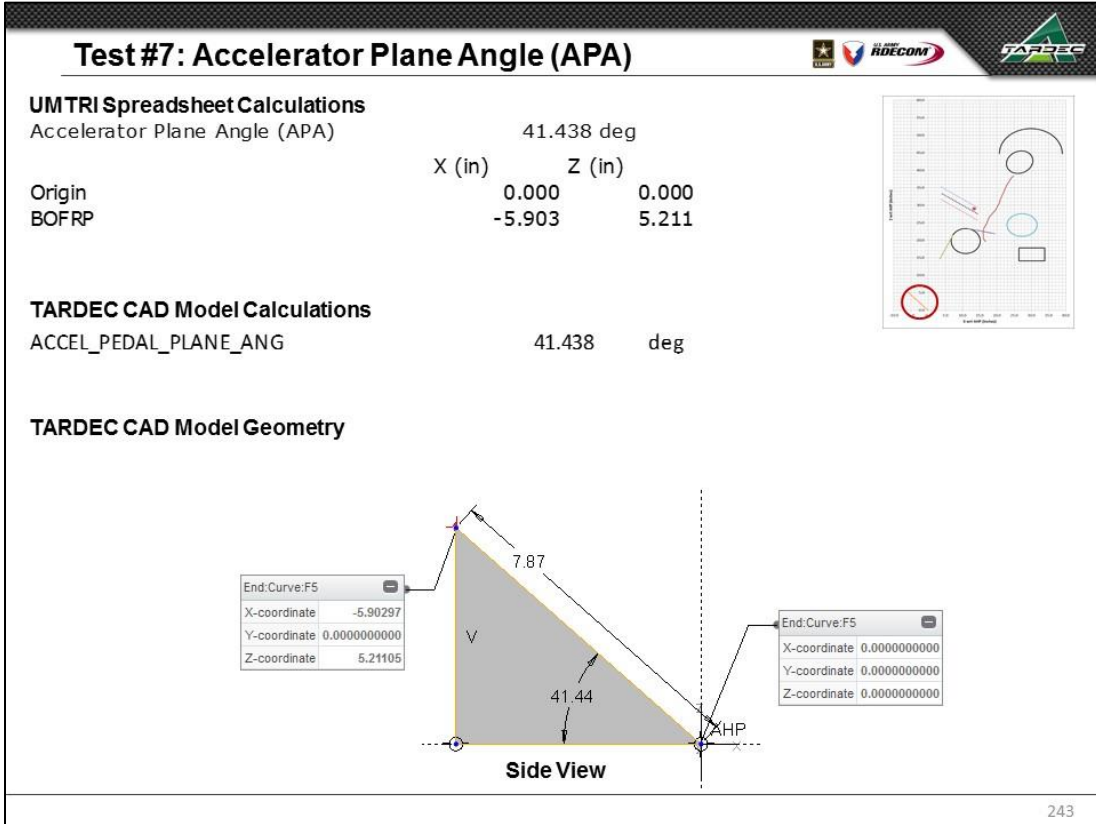

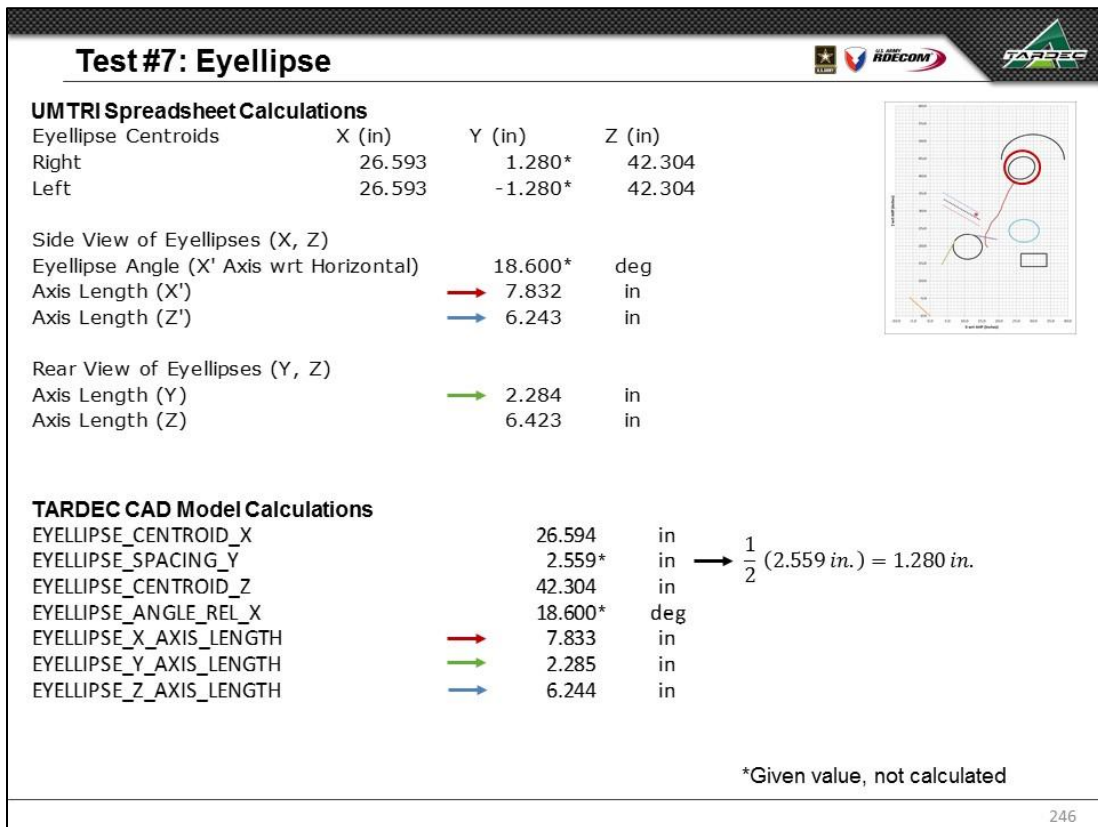
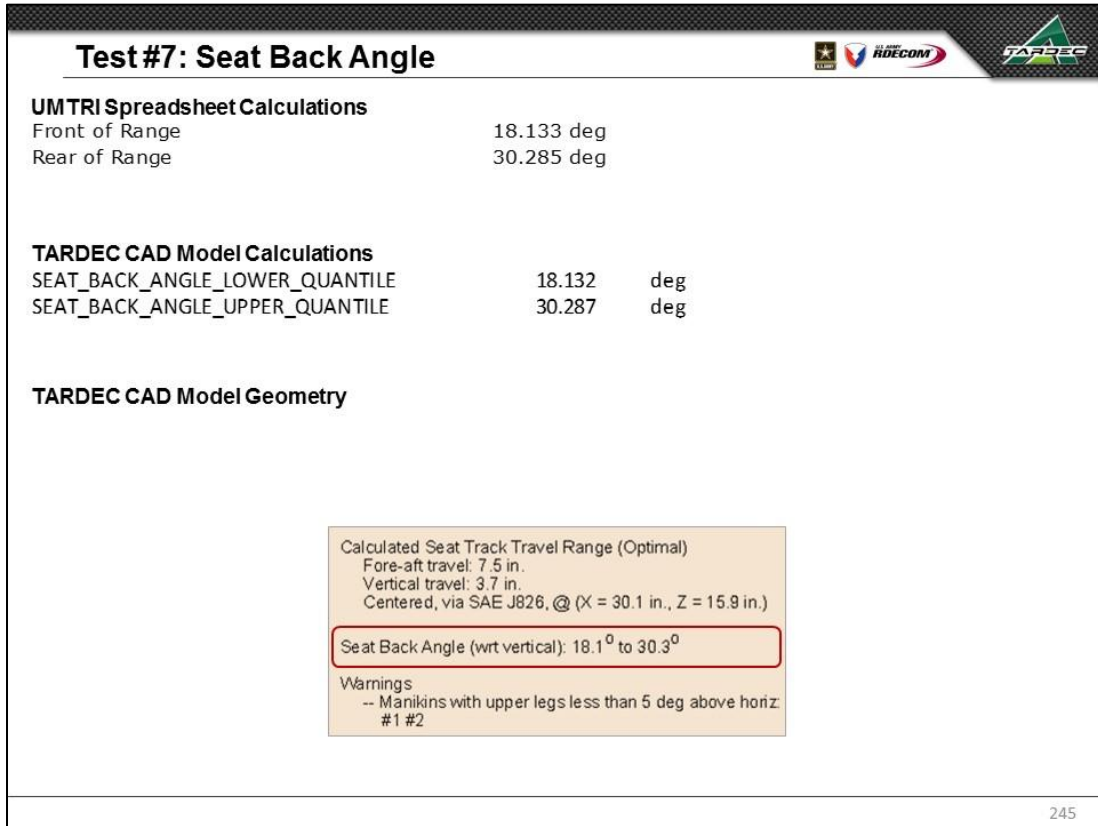

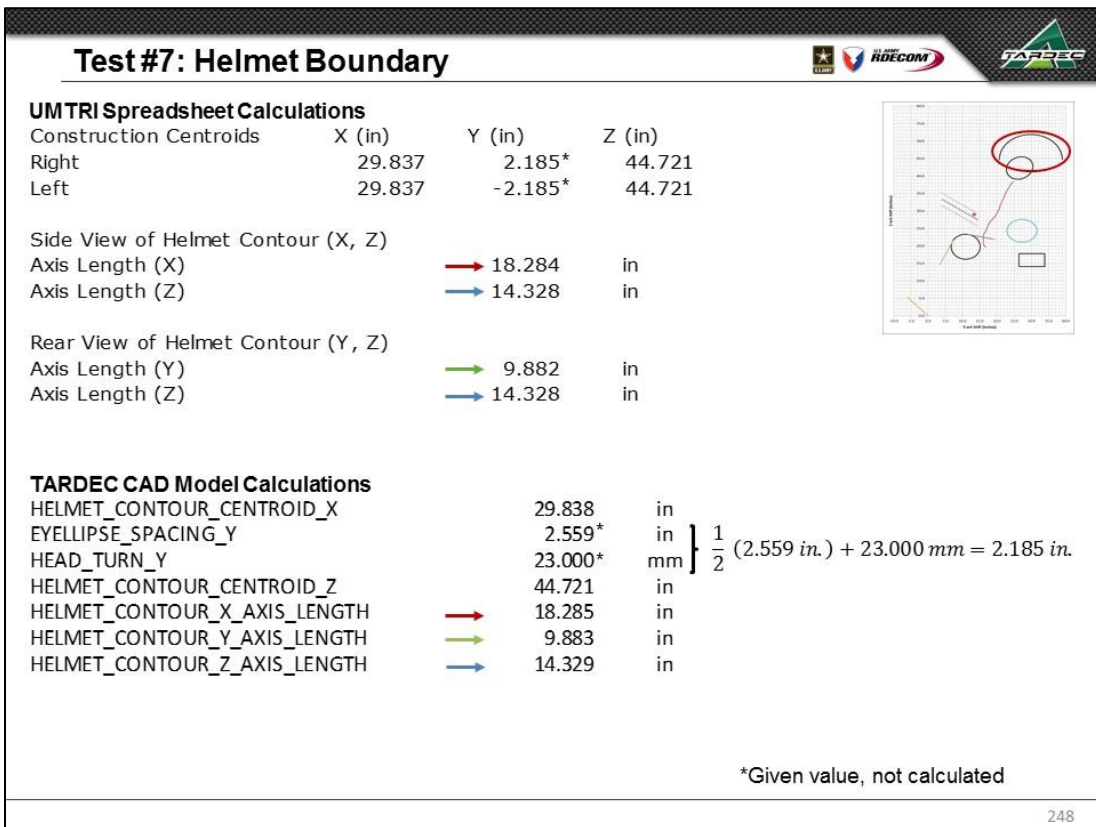
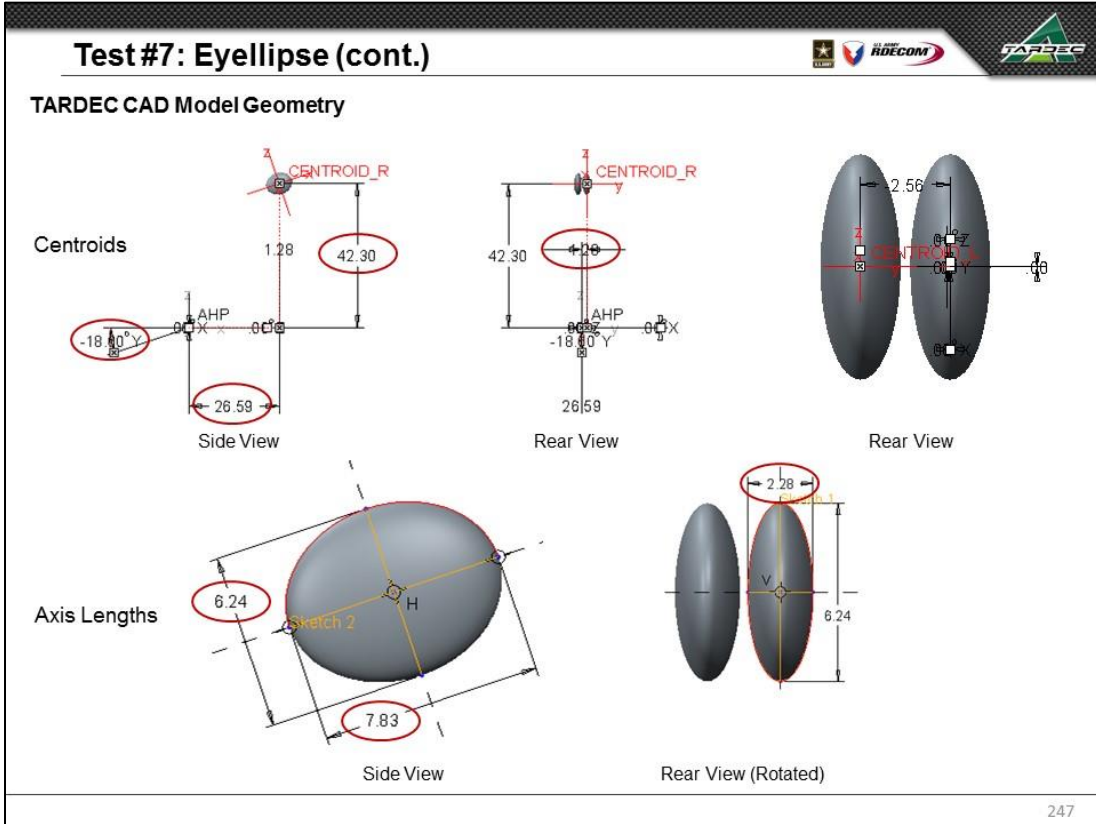

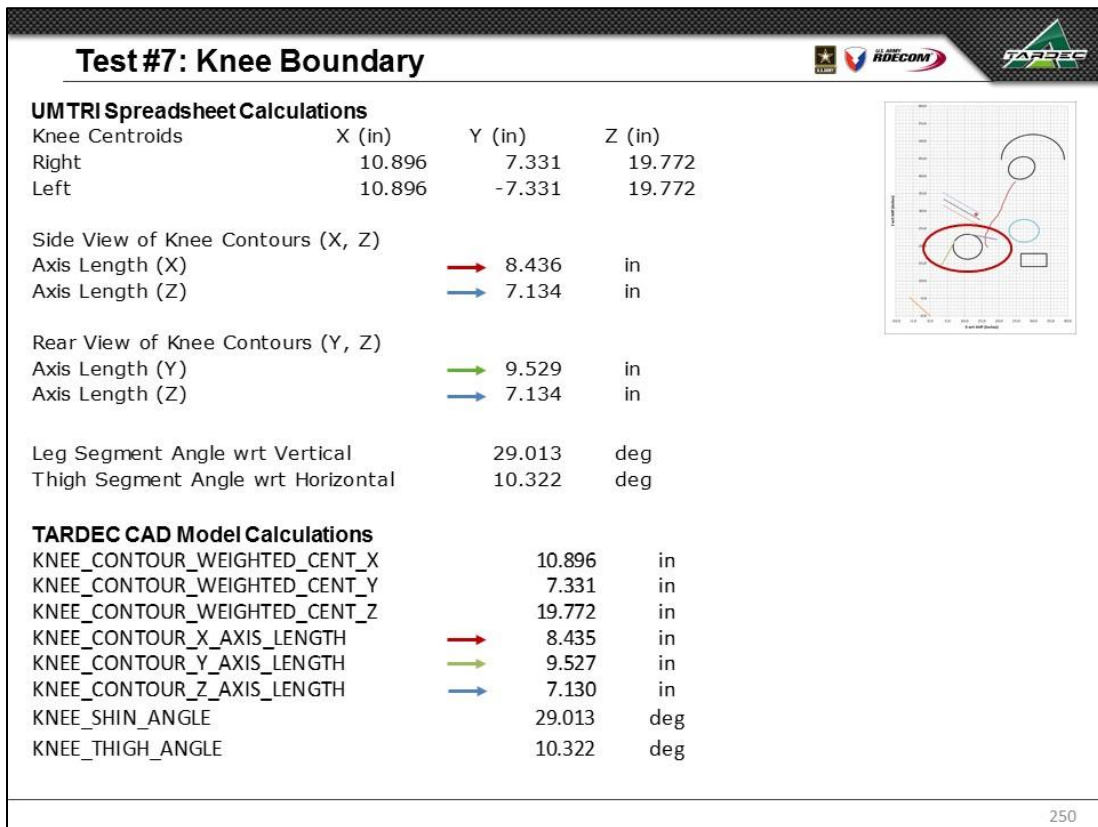
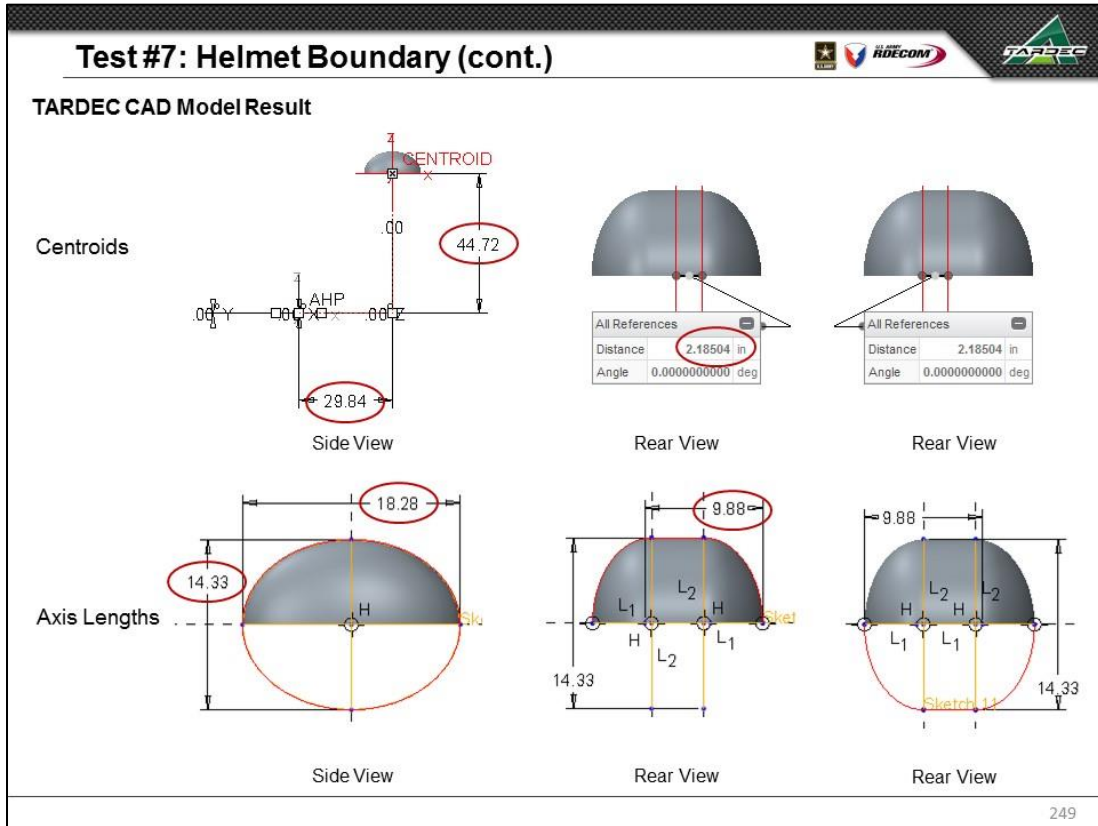

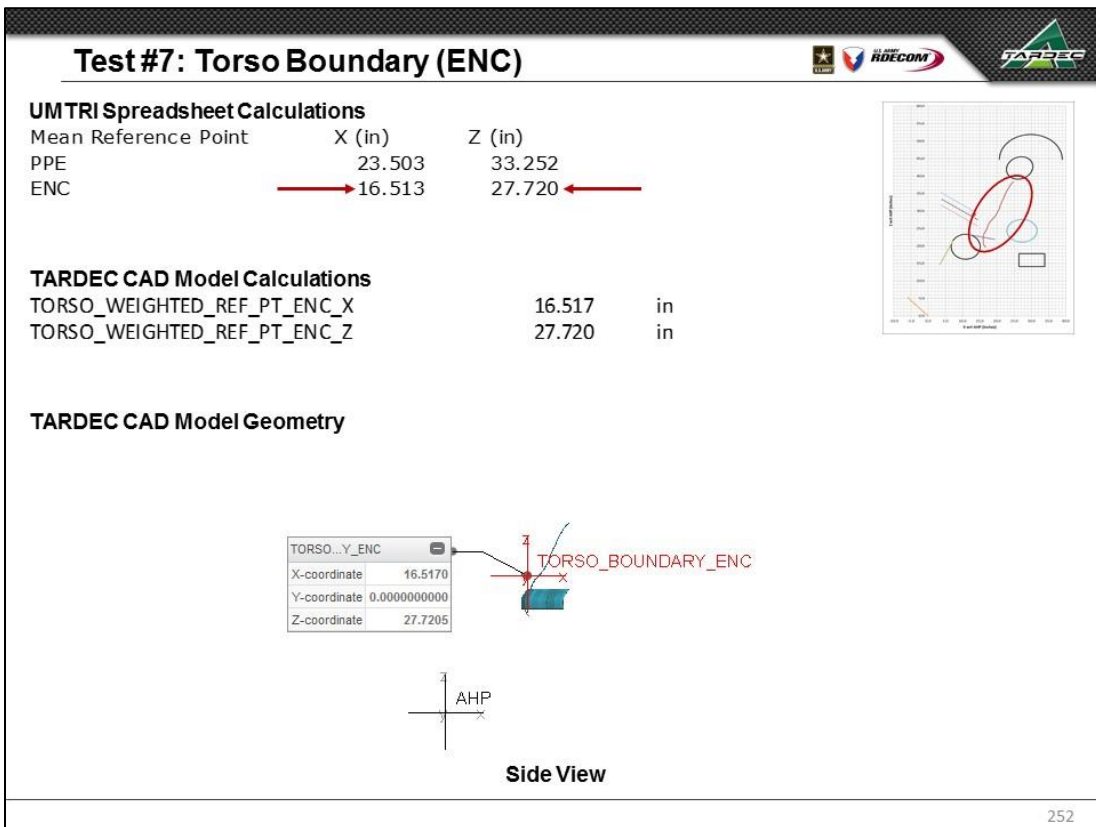
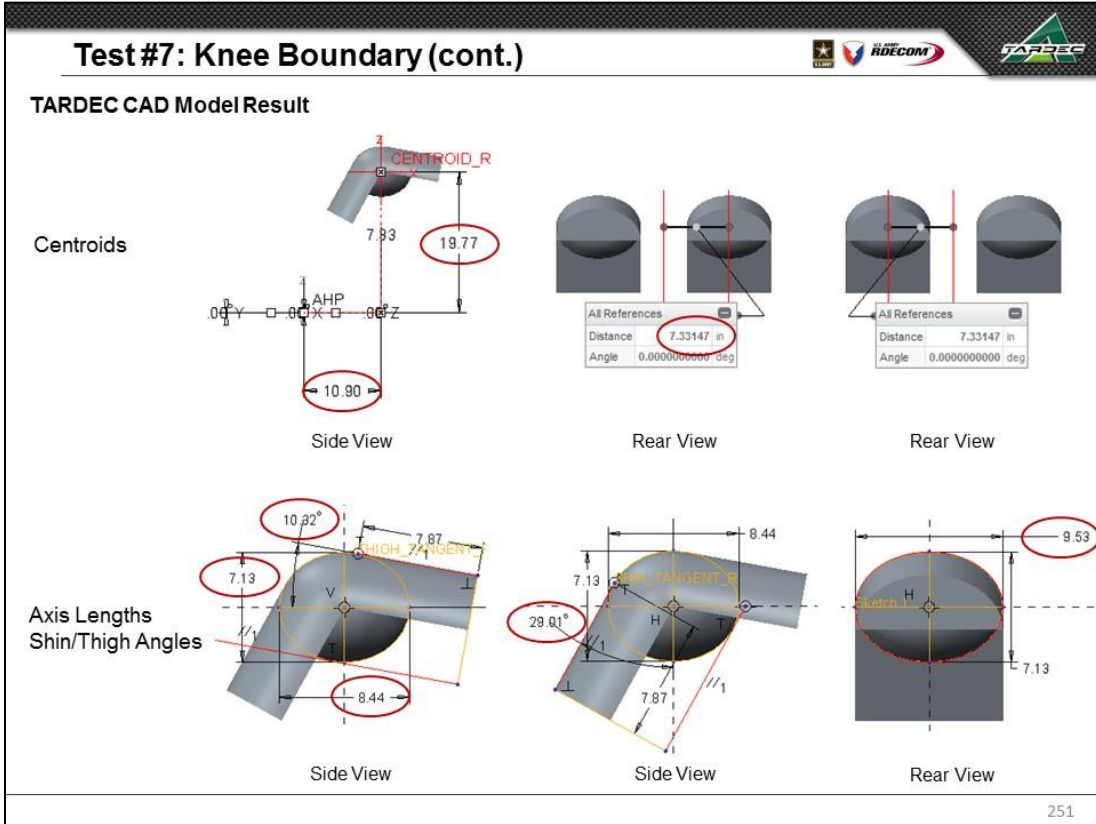

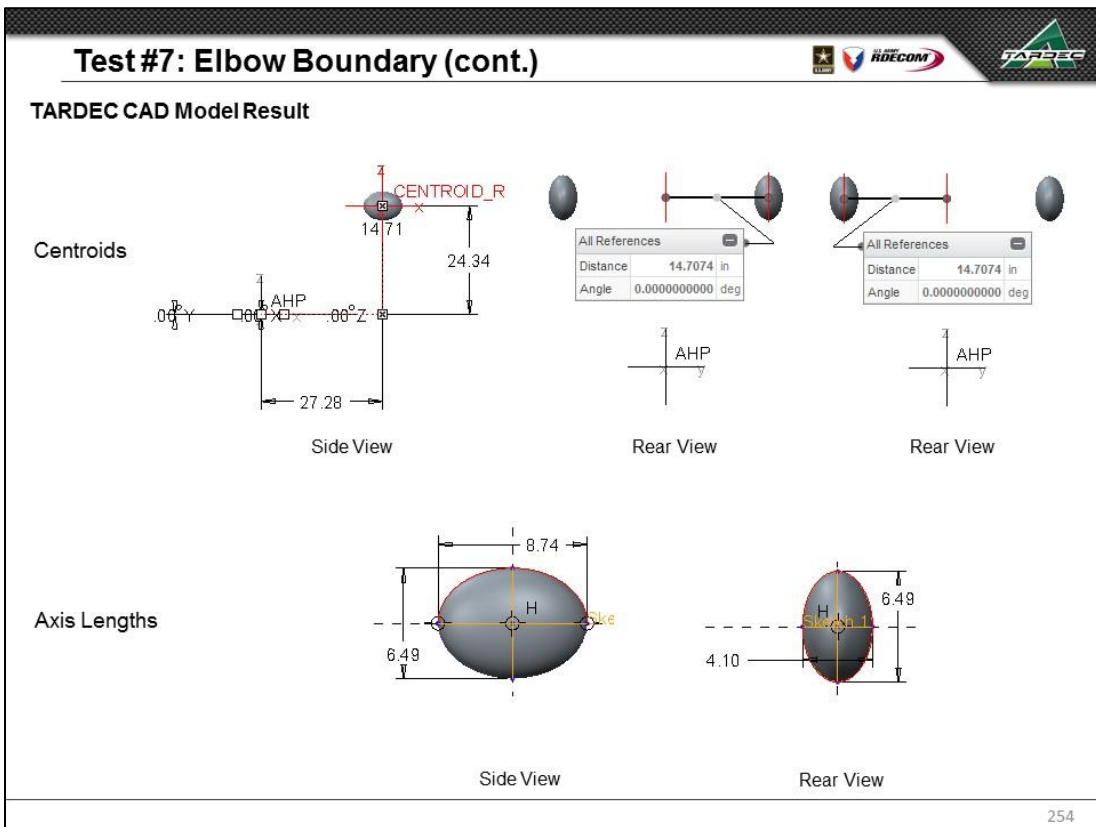
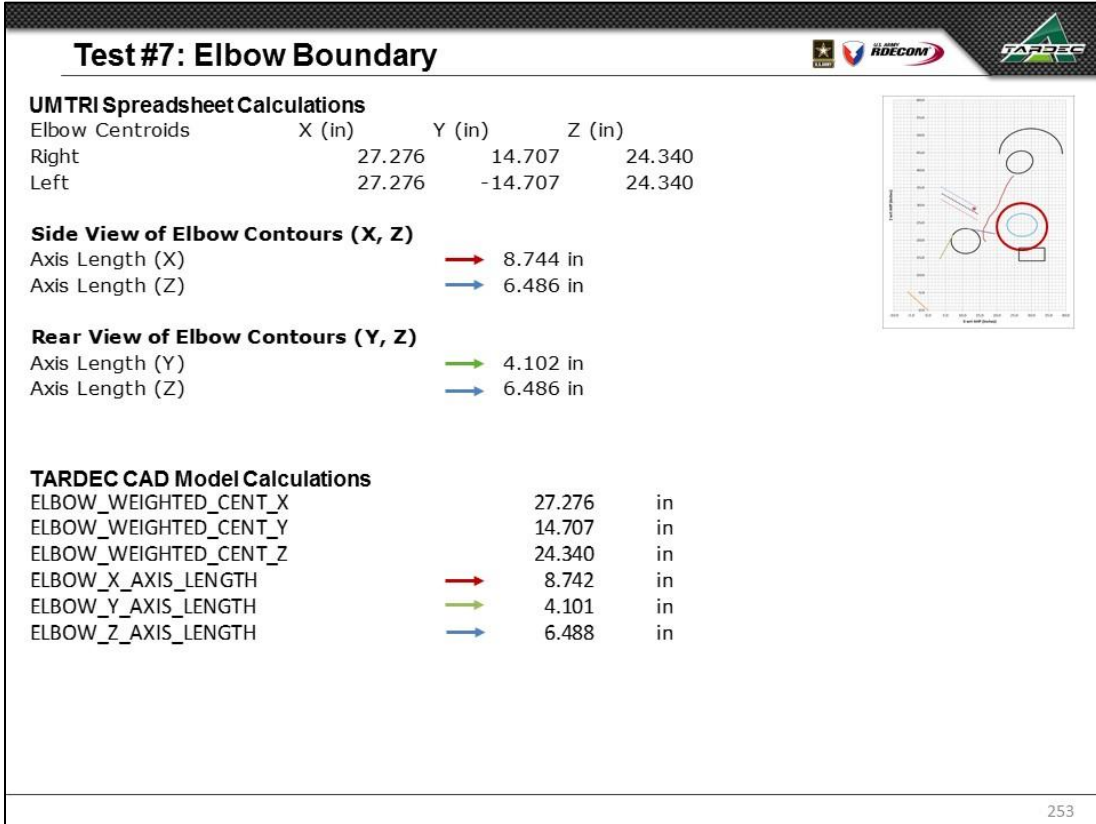

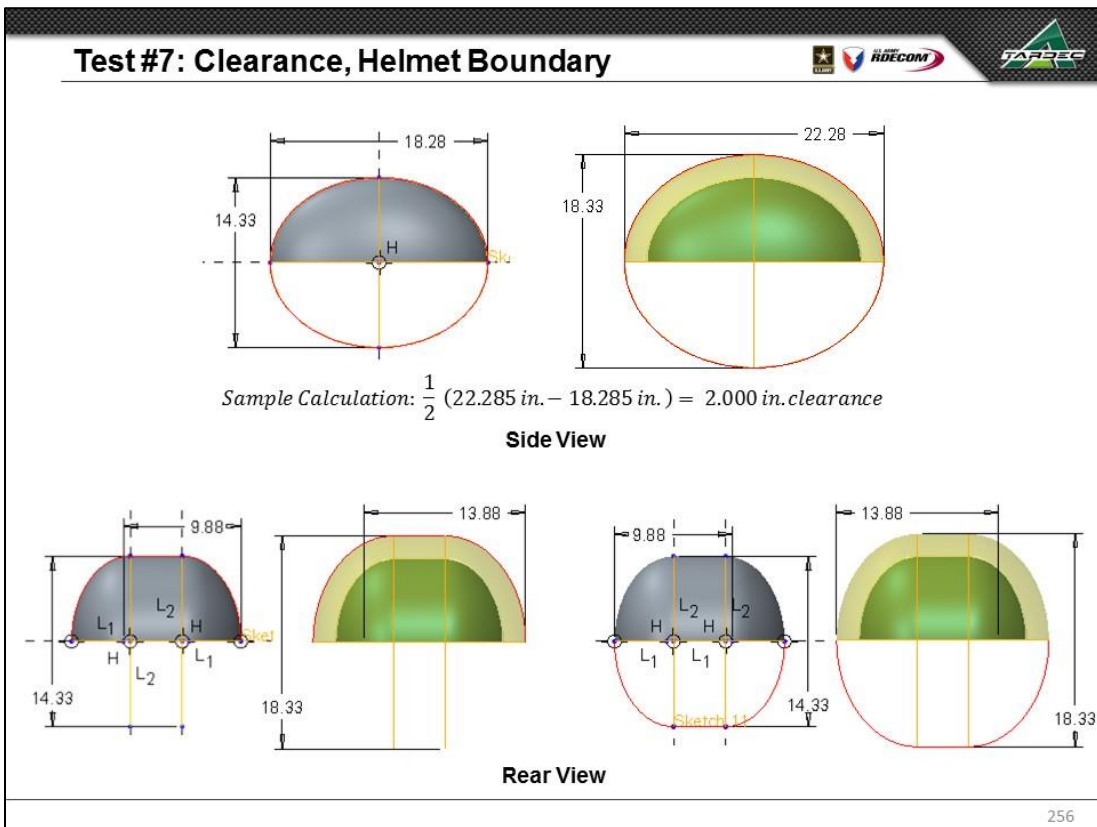
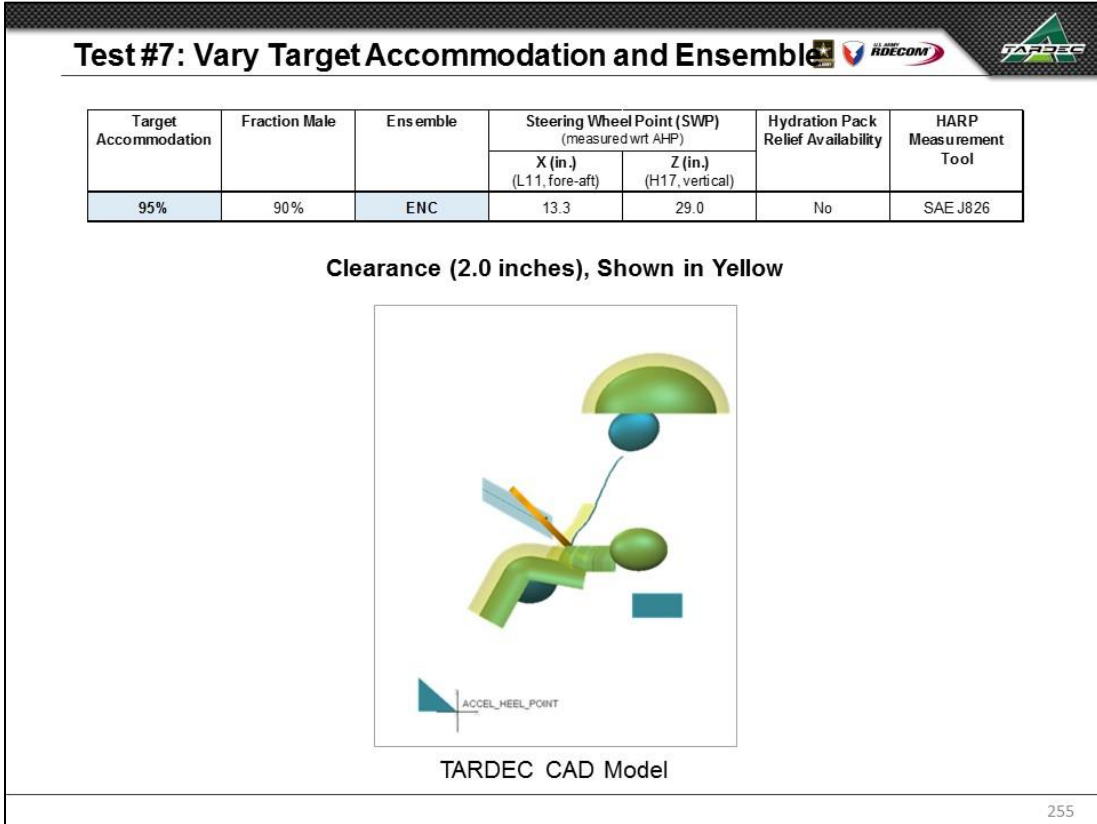

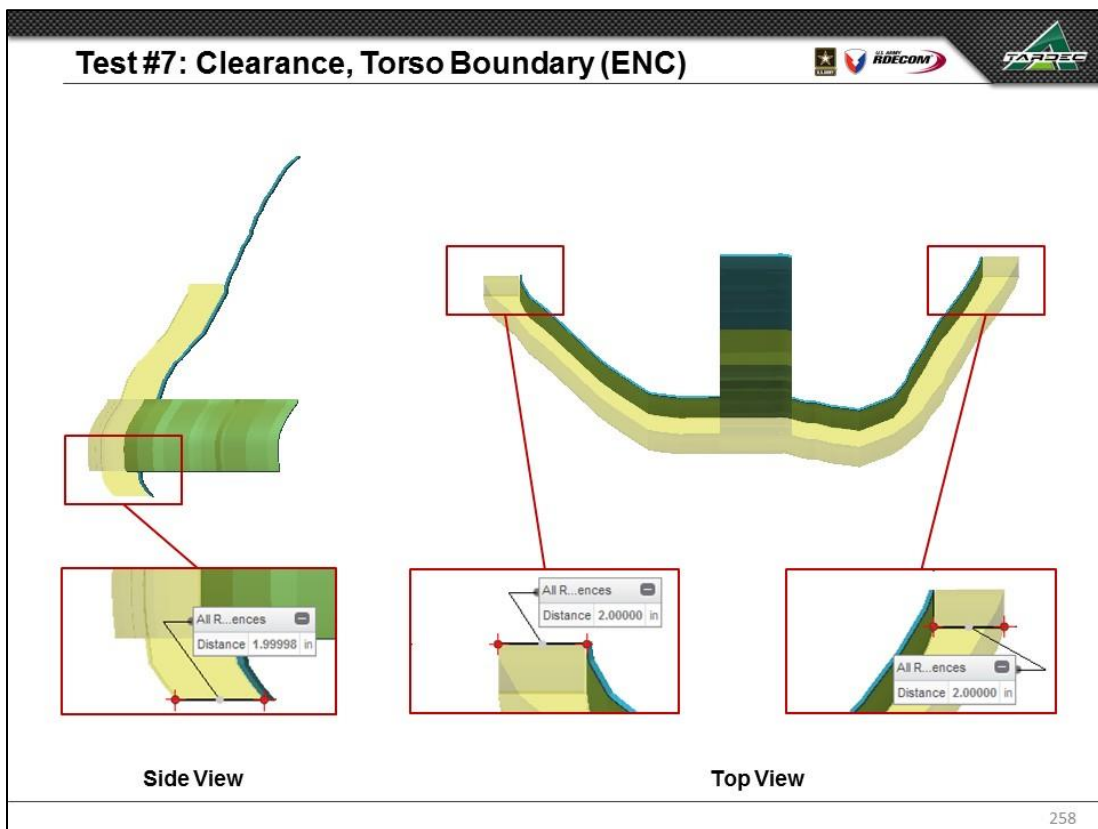
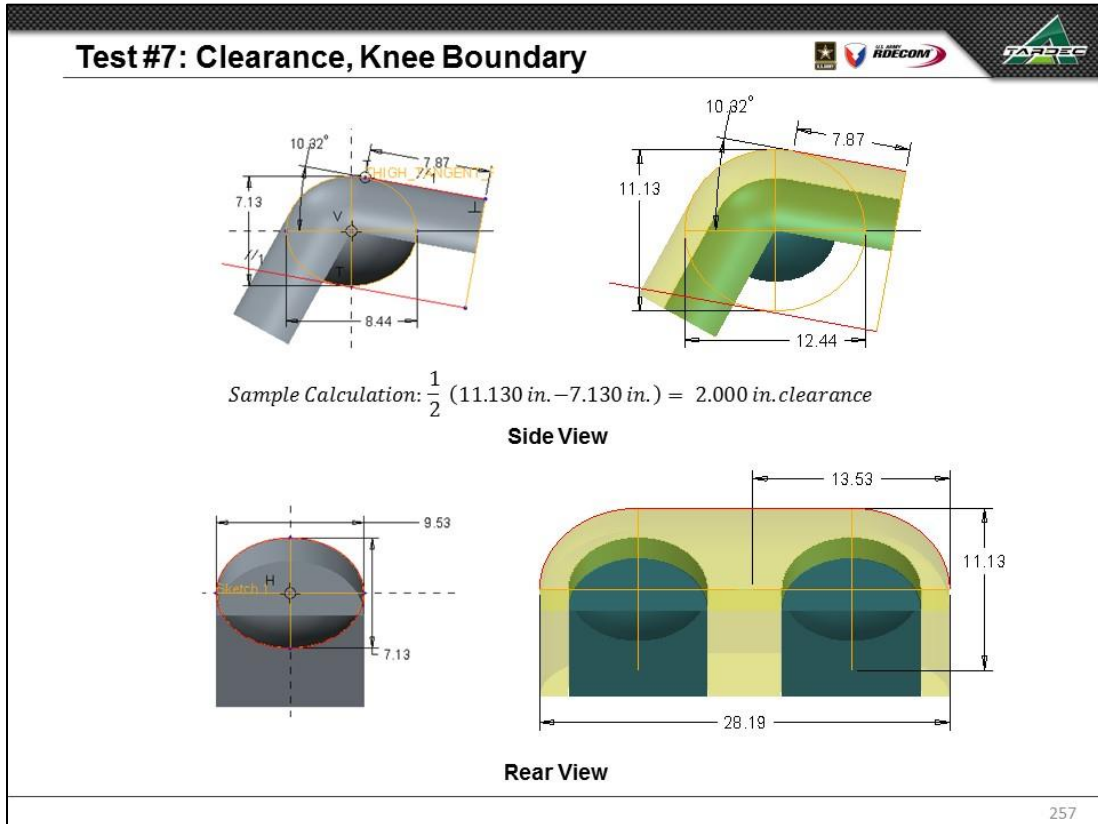

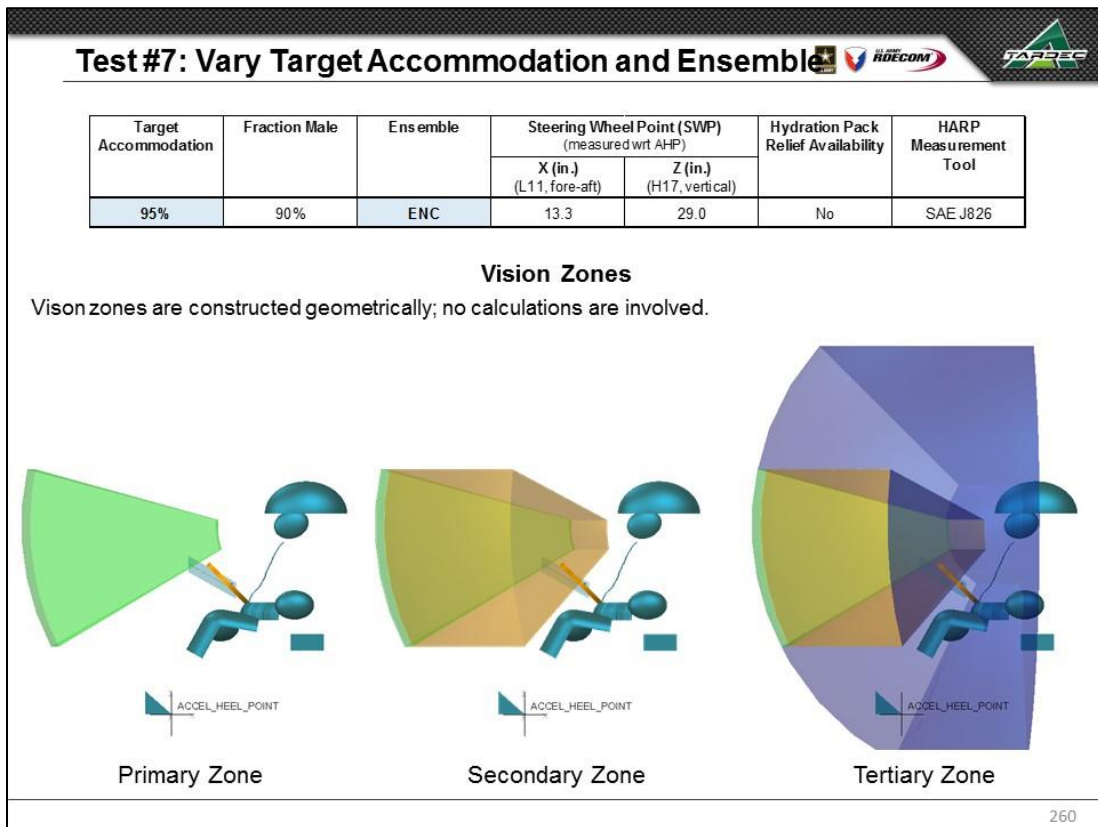
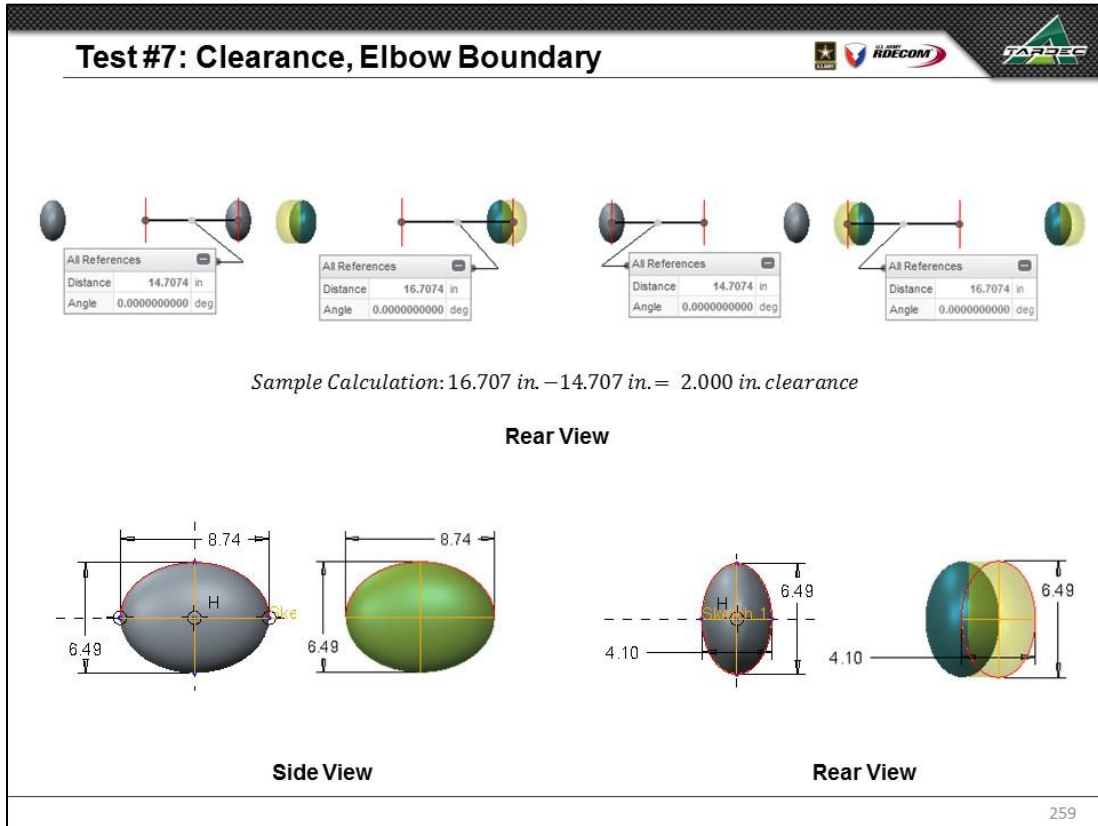

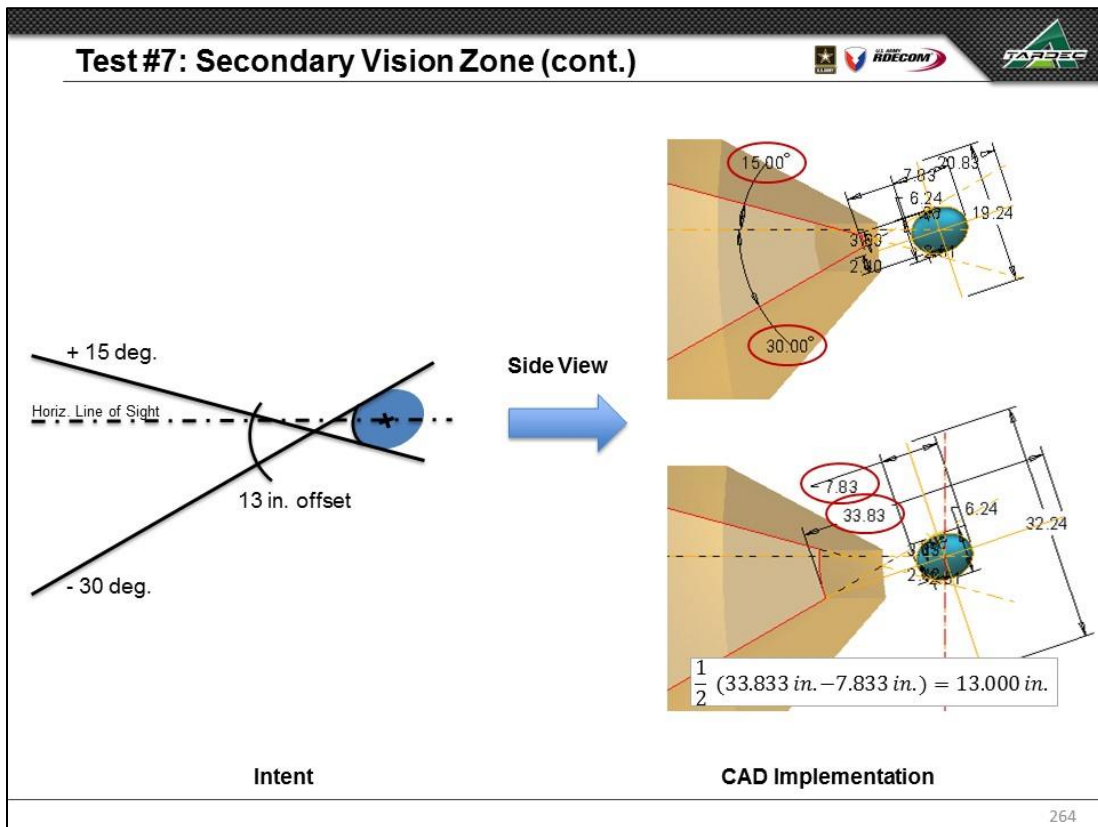
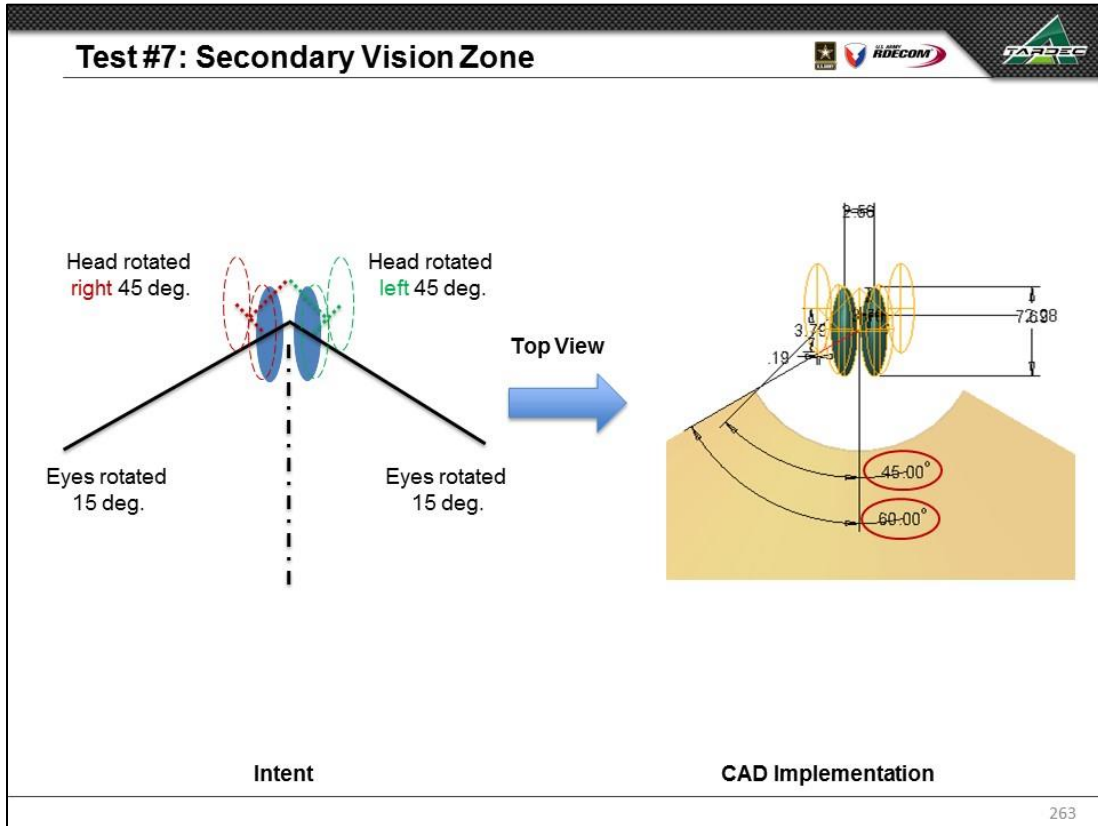

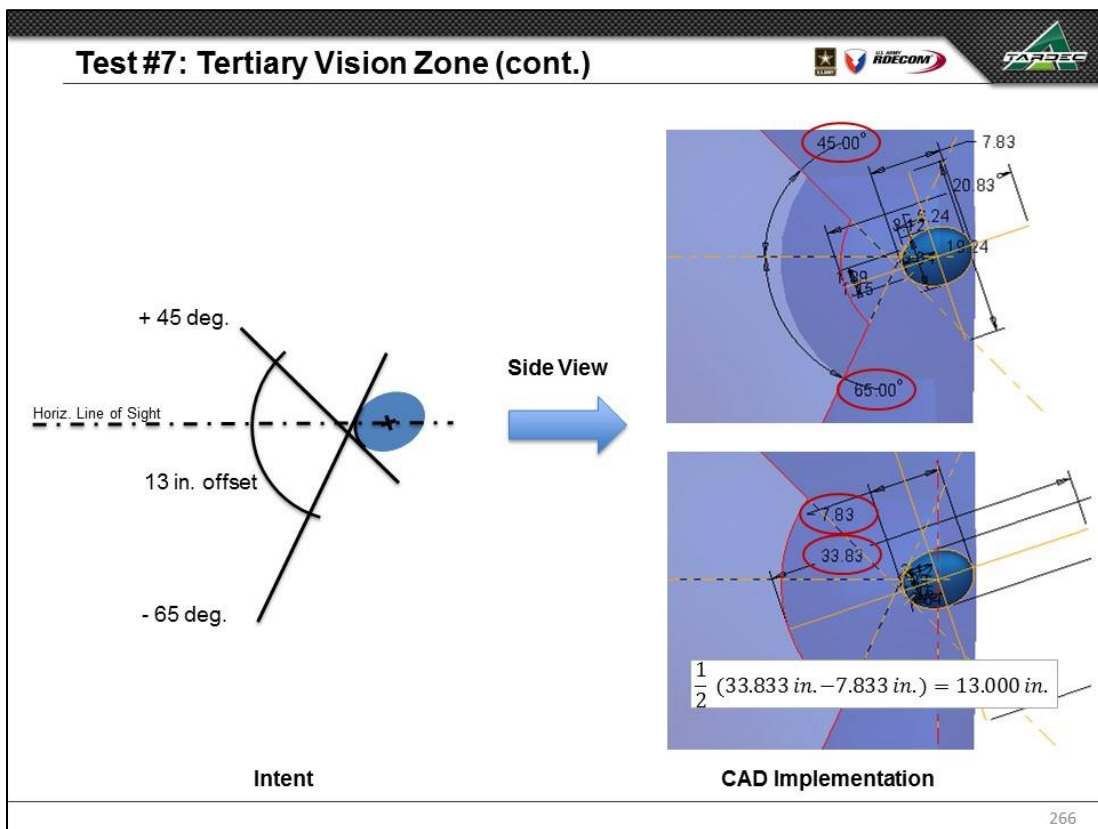
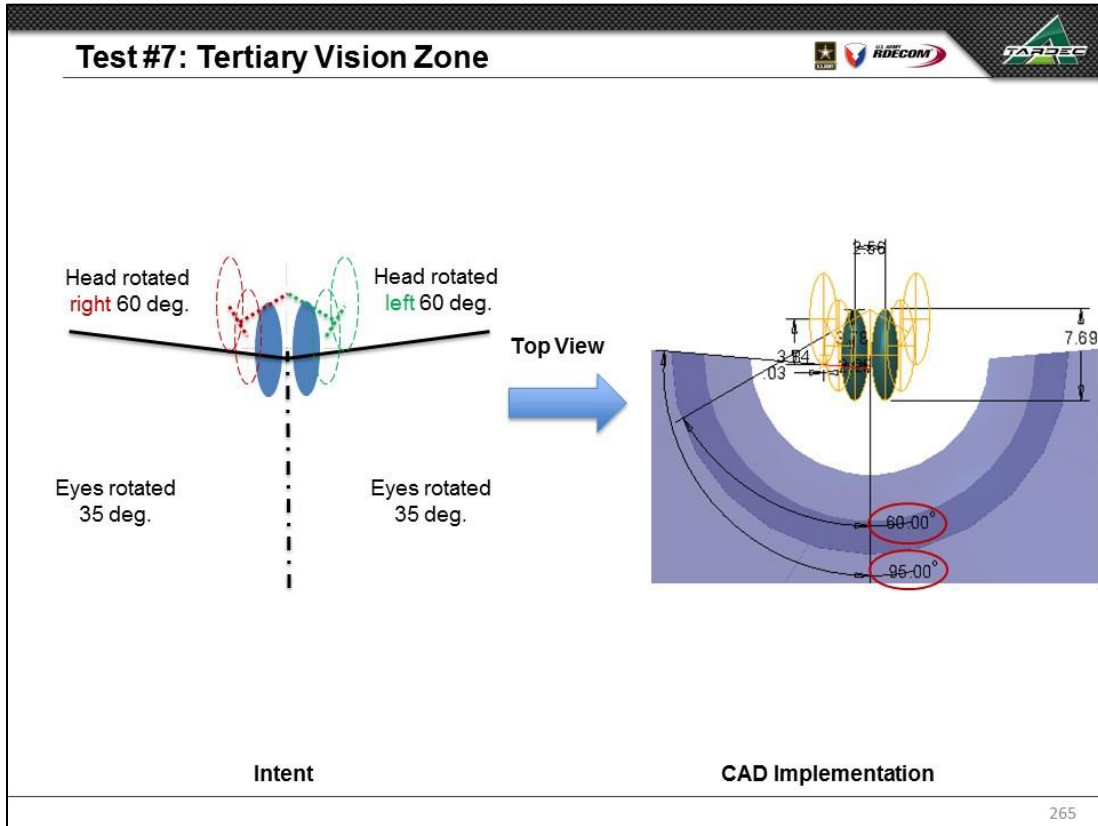



Test #7: Vary Target Accommodation and Ensemble

Target Accommodation	Fraction Male	Ensemble	Steering Wheel Point (SWP) (measured wrt AHP)		Hydration Pack Relief Availability	HARP Measurement Tool
			X (in.) (L11, fore-aft)	Z (in.) (H17, vertical)		
95%	90%	ENC	13.3	29.0	No	SAE J826

Boundary Manikin Posture and Position



TARDEC CAD Model

267

Test #7: Numerical Results, Manikin Positioning

Small Overall Female			
	UMTRI Value	TARDEC Value	Difference
POSTURE_DHM1_HIP_X	24.353 in	24.353 in	0.000 in
POSTURE_DHM1_HIP_Z	15.879 in	15.879 in	0.000 in
POSTURE_DHM1_EYE_X	24.822 in	24.822 in	0.000 in
POSTURE_DHM1_EYE_Z	38.171 in	38.171 in	0.000 in
Small Overall Male			
	UMTRI Value	TARDEC Value	Difference
POSTURE_DHM2_HIP_X	26.475 in	26.475 in	0.000 in
POSTURE_DHM2_HIP_Z	15.989 in	15.989 in	0.000 in
POSTURE_DHM2_EYE_X	26.073 in	26.073 in	0.000 in
POSTURE_DHM2_EYE_Z	39.938 in	39.938 in	0.000 in
Average Size Male			
	UMTRI Value	TARDEC Value	Difference
POSTURE_DHM3_HIP_X	28.670 in	28.670 in	0.000 in
POSTURE_DHM3_HIP_Z	15.988 in	15.988 in	0.000 in
POSTURE_DHM3_EYE_X	27.481 in	27.481 in	0.000 in
POSTURE_DHM3_EYE_Z	42.162 in	42.162 in	0.000 in
Widest Shoulders Male			
	UMTRI Value	TARDEC Value	Difference
POSTURE_DHM4_HIP_X	29.678 in	29.678 in	0.000 in
POSTURE_DHM4_HIP_Z	15.977 in	15.977 in	0.000 in
POSTURE_DHM4_EYE_X	28.137 in	28.137 in	0.000 in
POSTURE_DHM4_EYE_Z	43.440 in	43.440 in	0.000 in
Longest Torso Male			
	UMTRI Value	TARDEC Value	Difference
POSTURE_DHM5_HIP_X	28.922 in	28.922 in	0.000 in
POSTURE_DHM5_HIP_Z	15.971 in	15.971 in	0.000 in
POSTURE_DHM5_EYE_X	27.647 in	27.647 in	0.000 in
POSTURE_DHM5_EYE_Z	44.441 in	44.441 in	0.000 in
Longest Legs Male			
	UMTRI Value	TARDEC Value	Difference
POSTURE_DHM6_HIP_X	31.194 in	31.194 in	0.000 in
POSTURE_DHM6_HIP_Z	16.042 in	16.042 in	0.000 in
POSTURE_DHM6_EYE_X	29.058 in	29.058 in	0.000 in
POSTURE_DHM6_EYE_Z	42.661 in	42.661 in	0.000 in
Large Overall Male			
	UMTRI Value	TARDEC Value	Difference
POSTURE_DHM7_HIP_X	31.020 in	31.020 in	0.000 in
POSTURE_DHM7_HIP_Z	16.139 in	16.139 in	0.000 in
POSTURE_DHM7_EYE_X	28.834 in	28.834 in	0.000 in
POSTURE_DHM7_EYE_Z	44.400 in	44.400 in	0.000 in

TARDEC CAD values to agree with UMTRI spreadsheet values within
 ±0.100 inches
 ±0.100 degrees

Largest Observed Differences:
 0.000 inches

Values in agreement

268

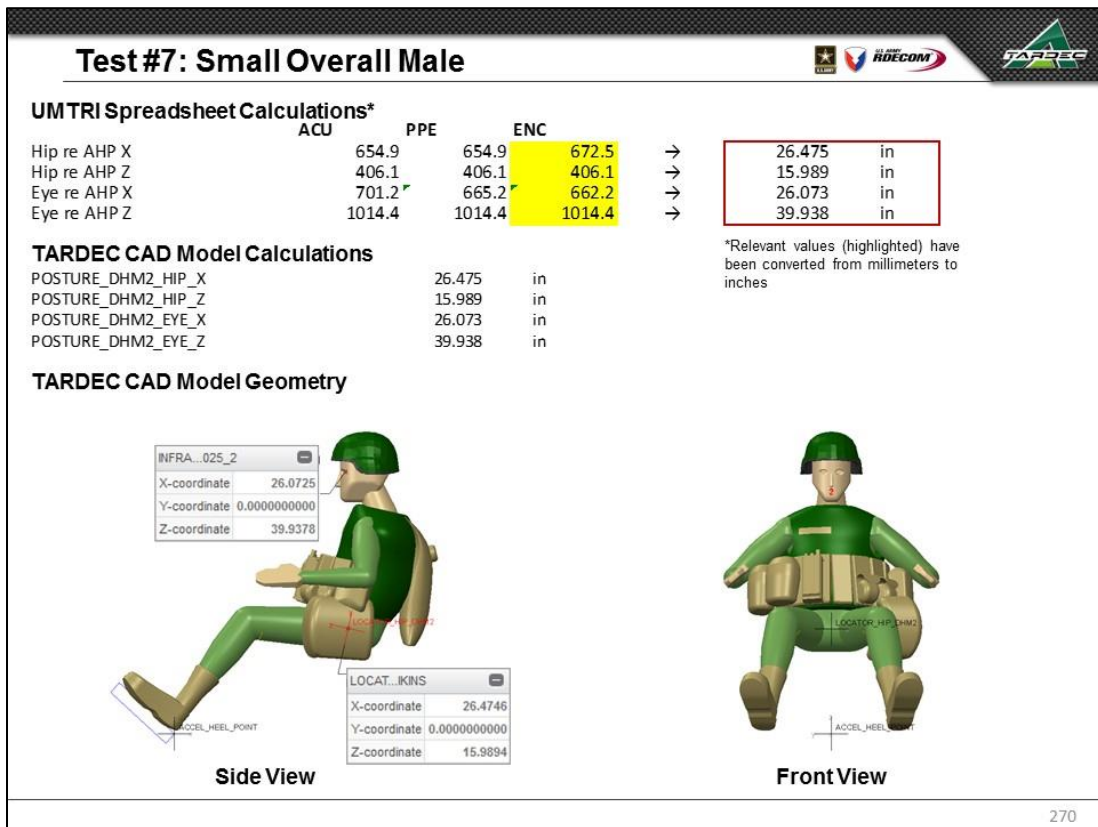
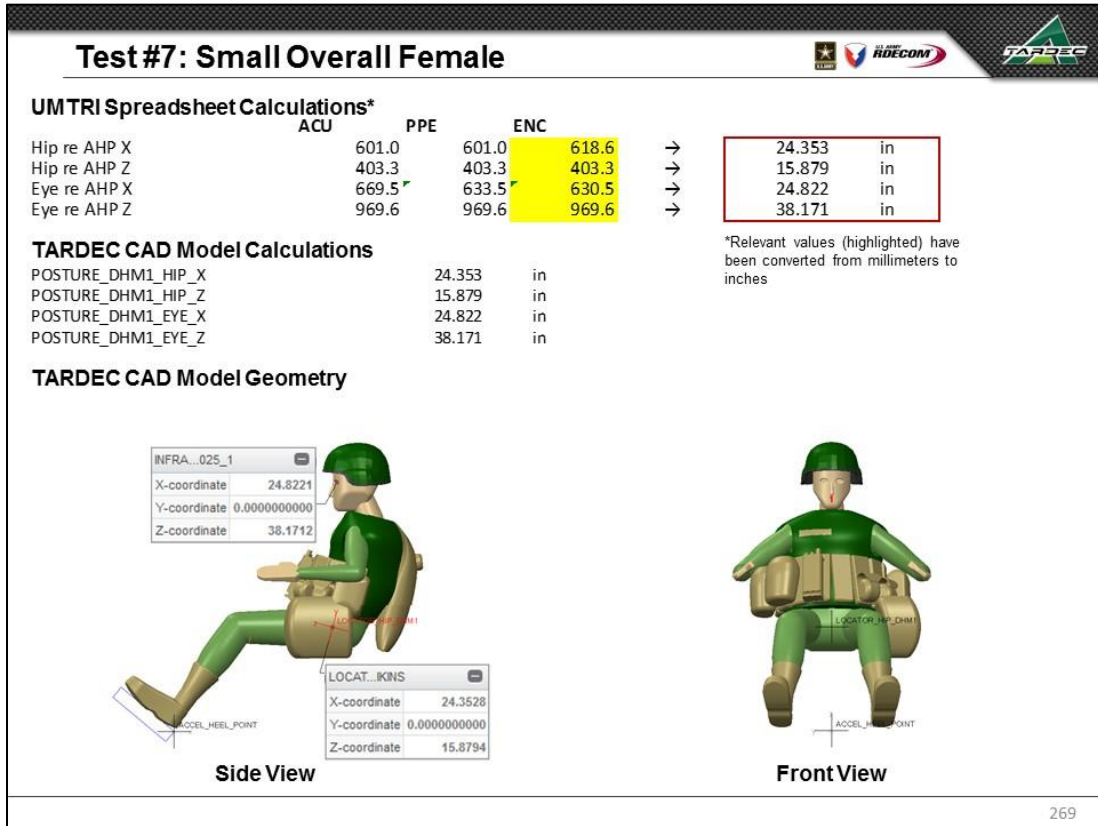

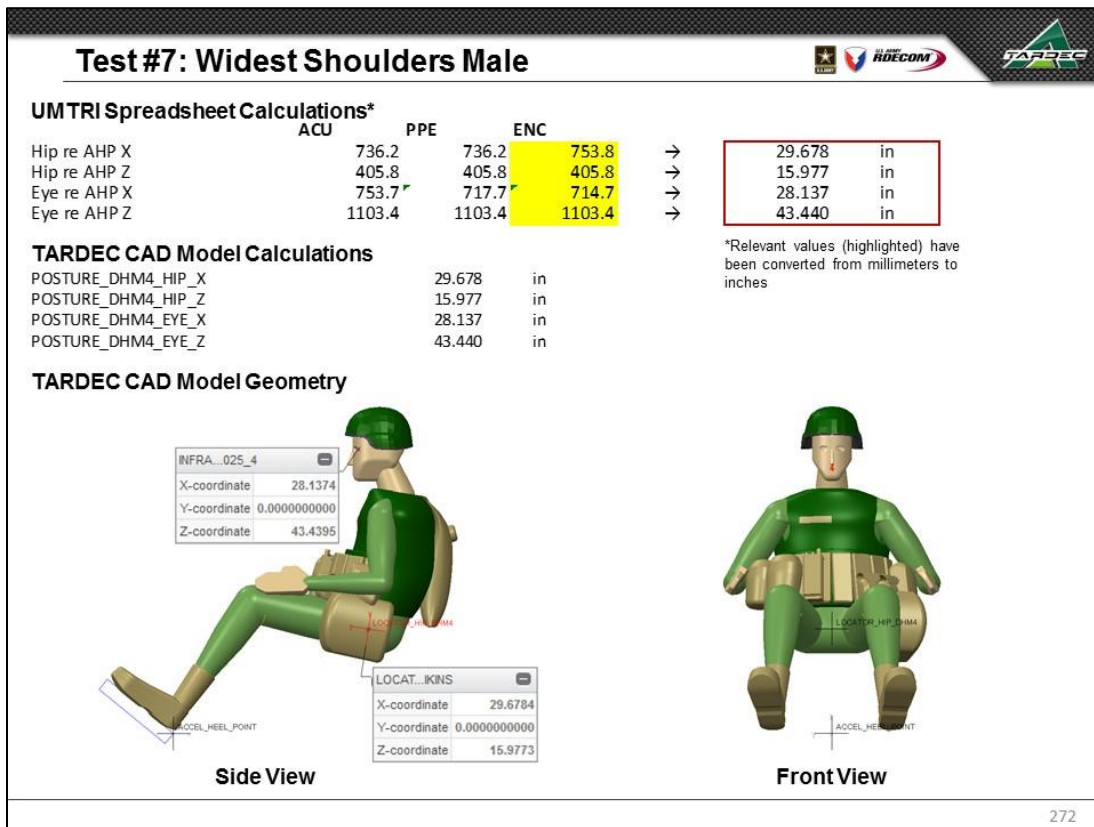
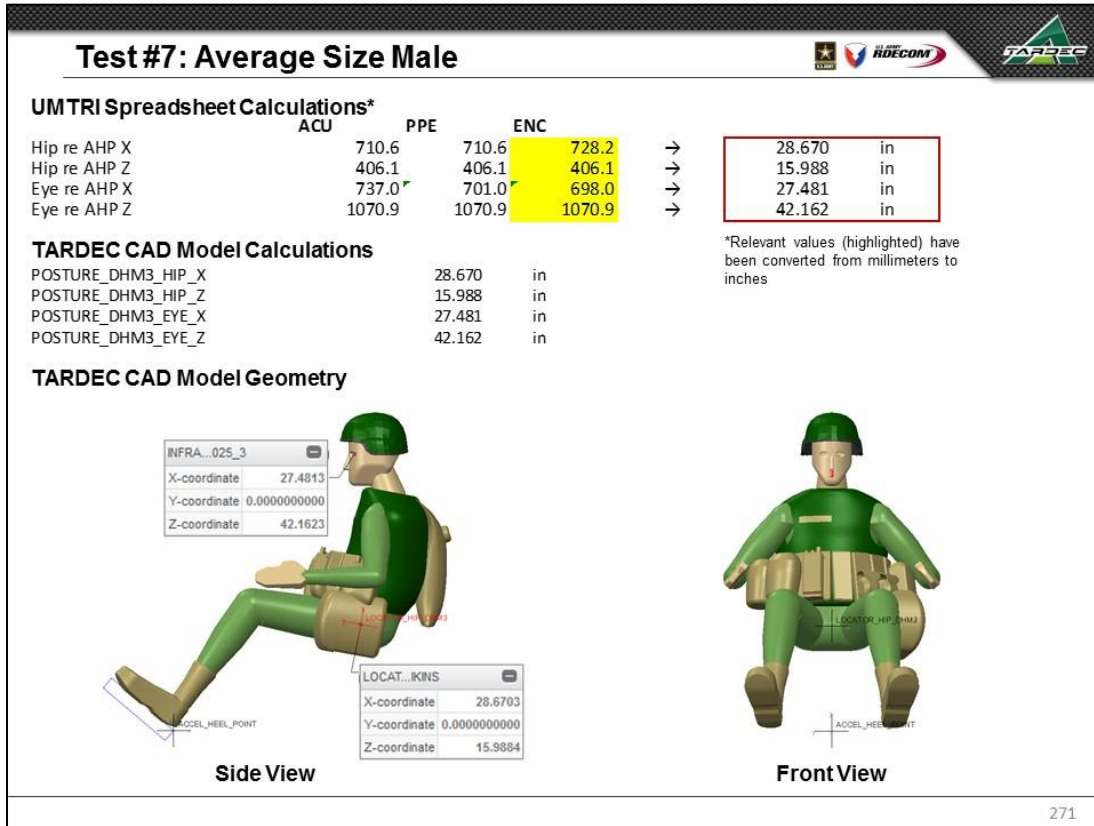

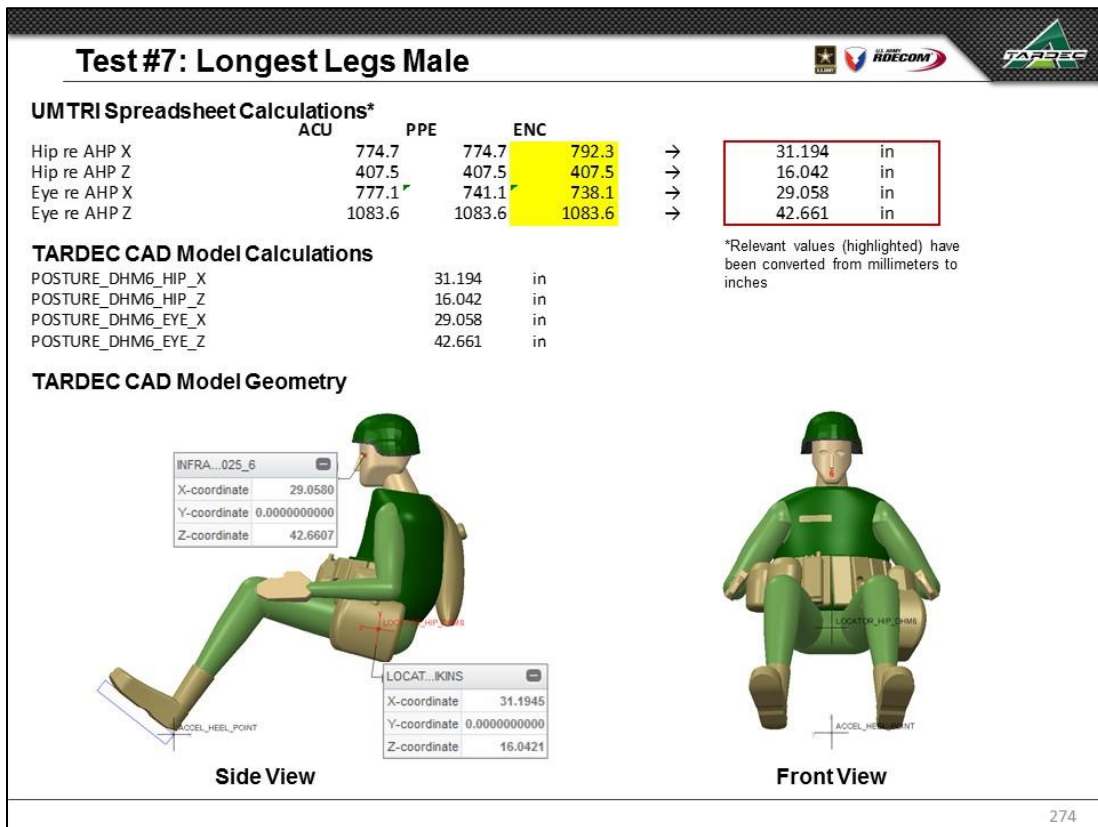
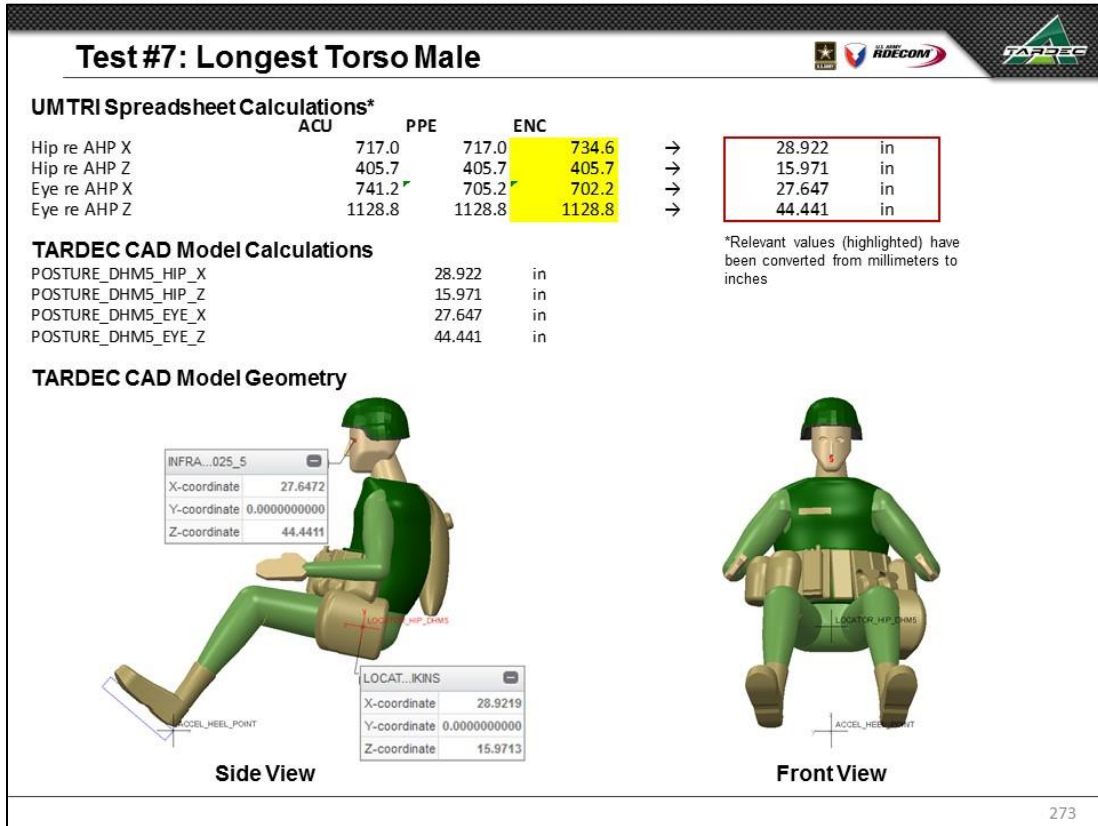

Test #7: Large Overall Male



UMTRI Spreadsheet Calculations*

	ACU	PPE	ENC		
Hip re AHP X	770.3	770.3	787.9	→	31.020 in
Hip re AHP Z	409.9	409.9	409.9	→	16.139 in
Eye re AHP X	771.4	735.4	732.4	→	28.834 in
Eye re AHP Z	1127.8	1127.8	1127.8	→	44.400 in

TARDEC CAD Model Calculations

POSTURE_DHM7_HIP_X	31.020	in
POSTURE_DHM7_HIP_Z	16.139	in
POSTURE_DHM7_EYE_X	28.834	in
POSTURE_DHM7_EYE_Z	44.400	in

TARDEC CAD Model Geometry

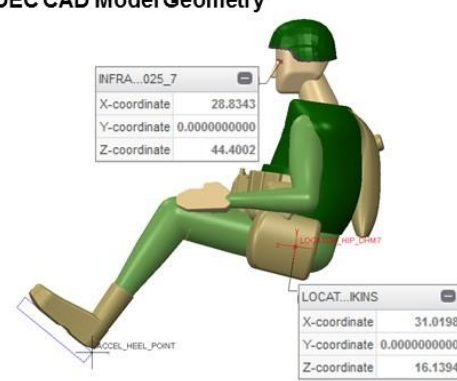

Side View



Front View

*Relevant values (highlighted) have been converted from millimeters to inches

275

10.7.8 TEST #8 – VARY GENDER MIX AND ENSEMBLE

Test #8: Vary Gender Mix and Ensemble

Target Accommodation	Fraction Male	Ensemble	Steering Wheel Point (SWP) (measured wrt AHP)		Hydration Pack Relief Availability	HARP Measurement Tool
			X (in.) (L11, fore-aft)	Z (in.) (H17, vertical)		
90%	50%	PPE	13.3	29.0	No	SAE J826

Basic Accommodation

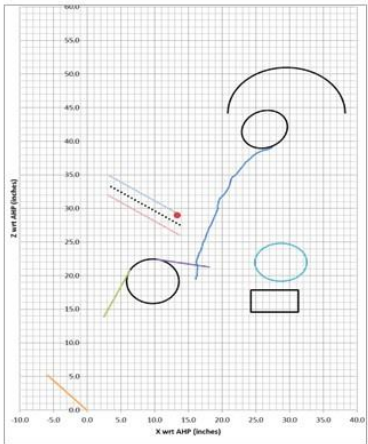

UMTRI Spreadsheet

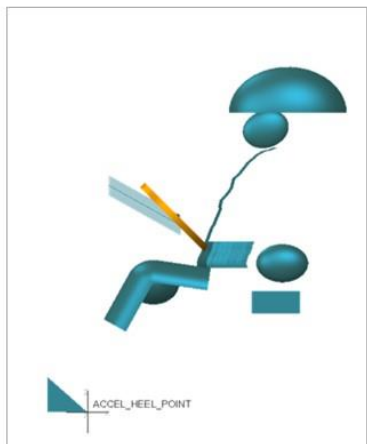

TARDEC CAD Model

276

Surrogate Steering Wheel			
	UMTRI Value	TARDEC Value	Difference
STEERING_WHEEL_X	13.300 in	13.300 in	0.000 in
STEERING_WHEEL_Z	29.000 in	29.000 in	0.000 in
Steering Wheel Preference Line			
	UMTRI Value	TARDEC Value	Difference
STRG_WHL_FWD_X	13.716 in	13.716 in	0.000 in
STRG_WHL_FWD_Z	27.559 in	27.559 in	0.000 in
STRG_WHL_RWD_X	3.151 in	3.151 in	0.000 in
STRG_WHL_RWD_Z	33.465 in	33.465 in	0.000 in
Steering Wheel Preference Zone			
	UMTRI Value	TARDEC Value	Difference
STRG_WHL_ZONE_Z	1.516 in	1.516 in	0.001 in
STRG_WHL_ZONE_Y	N/A	1.000 in	N/A
Accelerator Plane Angle (APA)			
	UMTRI Value	TARDEC Value	Difference
ACCEL_PEDAL_PLANE_ANG	41.438 deg	41.438 deg	0.000 deg
Origin (X)	0.000 in	0.000 in	0.000 in
Origin (Z)	0.000 in	0.000 in	0.000 in
BOFRP (X)	-5.903 in	-5.903 in	0.000 in
BOFRP (Z)	5.211 in	5.211 in	0.000 in
Seat Track Travel Range			
	UMTRI Value	TARDEC Value	Difference
SEAT_POSITION_CTR_OF_TRAVEL_X	27.766 in	27.766 in	0.000 in
SEAT_POSITION_CTR_OF_TRAVEL_Z	16.220 in	16.220 in	0.000 in
SEAT_POSITION_FORE_AFT_TRAVEL	7.045 in	7.044 in	0.000 in
SEAT_POSITION_VERTICAL_TRAVEL	3.234 in	3.236 in	0.001 in
Seat Back Angle			
	UMTRI Value	TARDEC Value	Difference
SEAT_BACK_ANGLE_LOWER_QUANTILE	16.510 deg	16.507 deg	0.004 deg
SEAT_BACK_ANGLE_UPPER_QUANTILE	26.708 deg	26.712 deg	0.004 deg
Eyellipse			
	UMTRI Value	TARDEC Value	Difference
EYELIPSE_CENTROID_X	26.271 in	26.271 in	0.000 in
EYELIPSE_CENTROID_Y (+/-)	1.280 in	1.280 in	0.000 in
EYELIPSE_CENTROID_Z	41.779 in	41.779 in	0.000 in
EYELIPSE_ANGLE_REL_X	18.600 deg	18.600 deg	0.000 deg
EYELIPSE_X_AXIS_LENGTH	6.889 in	6.890 in	0.001 in
EYELIPSE_Y_AXIS_LENGTH	1.917 in	1.918 in	0.001 in
EYELIPSE_Z_AXIS_LENGTH	5.484 in	5.486 in	0.002 in

Helmet Boundary			
	UMTRI Value	TARDEC Value	Difference
HELMET_CONTOUR_CBTRDROID_X	29.515 in	29.515 in	0.000 in
HELMET_CONTOUR_CBTRDROID_Y (+/-)	2.185 in	2.185 in	0.000 in
HELMET_CONTOUR_CBTRDROID_Z	44.196 in	44.196 in	0.000 in
HELMET_CONTOUR_X_AXIS_LENGTH	17.358 in	17.359 in	0.001 in
HELMET_CONTOUR_Y_AXIS_LENGTH	9.515 in	9.517 in	0.001 in
HELMET_CONTOUR_Z_AXIS_LENGTH	13.548 in	13.550 in	0.002 in
Knee Boundary			
	UMTRI Value	TARDEC Value	Difference
KNEE_CONTOUR_WEIGHTED_CENT_X	9.709 in	9.709 in	0.000 in
KNEE_CONTOUR_WEIGHTED_CENT_Y (+/-)	6.817 in	6.817 in	0.000 in
KNEE_CONTOUR_WEIGHTED_CENT_Z	19.163 in	19.163 in	0.000 in
KNEE_CONTOUR_X_AXIS_LENGTH	7.753 in	7.754 in	0.001 in
KNEE_CONTOUR_Y_AXIS_LENGTH	8.895 in	8.896 in	0.000 in
KNEE_CONTOUR_Z_AXIS_LENGTH	6.615 in	6.615 in	0.000 in
KNEE_SHIN_ANGLE	29.013 deg	29.013 deg	0.000 deg
KNEE_THIGH_ANGLE	8.489 deg	8.489 deg	0.000 deg
Torso Boundary			
	UMTRI Value	TARDEC Value	Difference
TORSO_WEIGHTED_REF_PT_PFE_X	21.517 in	21.517 in	0.000 in
TORSO_WEIGHTED_REF_PT_PFE_Z	33.076 in	33.076 in	0.000 in
Elbow Boundary			
	UMTRI Value	TARDEC Value	Difference
ELBOW_WEIGHTED_CBNT_X	28.690 in	28.690 in	0.000 in
ELBOW_WEIGHTED_CBNT_Y (+/-)	11.922 in	11.922 in	0.000 in
ELBOW_WEIGHTED_CBNT_Z	21.981 in	21.981 in	0.000 in
ELBOW_X_AXIS_LENGTH	7.683 in	7.681 in	0.000 in
ELBOW_Y_AXIS_LENGTH	3.599 in	3.599 in	0.000 in
ELBOW_Z_AXIS_LENGTH	5.652 in	5.655 in	0.003 in

TARDEC CAD values to agree with UMTRI spreadsheet values within
 ±0.100 inches
 ±0.100 degrees

Largest Observed Differences:
 0.003 inches
 0.004 degrees

Values in agreement

277

Test #8: Surrogate Steering Wheel

UMTRI Spreadsheet Calculations

	L11 (in)	H17 (in)
Steering Wheel Point (SWP)	13.300	29.000

TARDEC CAD Model Calculations

STEERING_WHEEL_X	13.300	in
STEERING_WHEEL_Z	29.000	in

TARDEC CAD Model Geometry

Side View

Steering Wheel Geometry

278

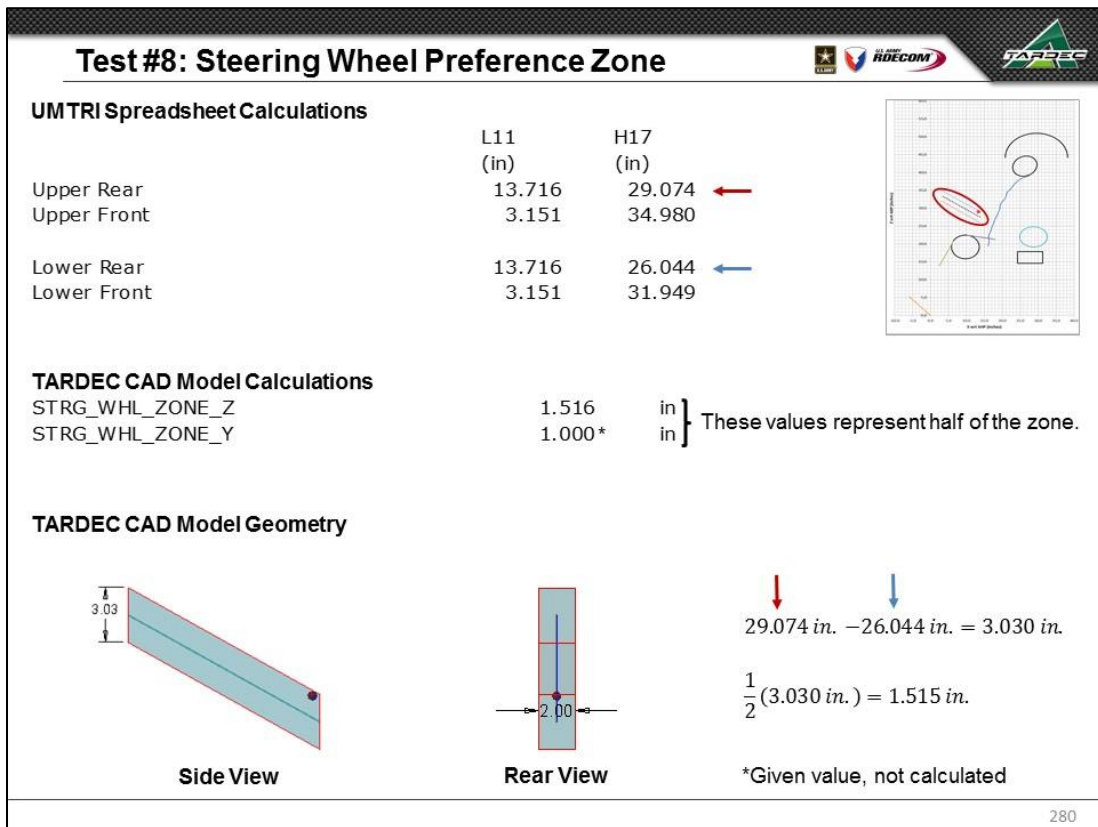
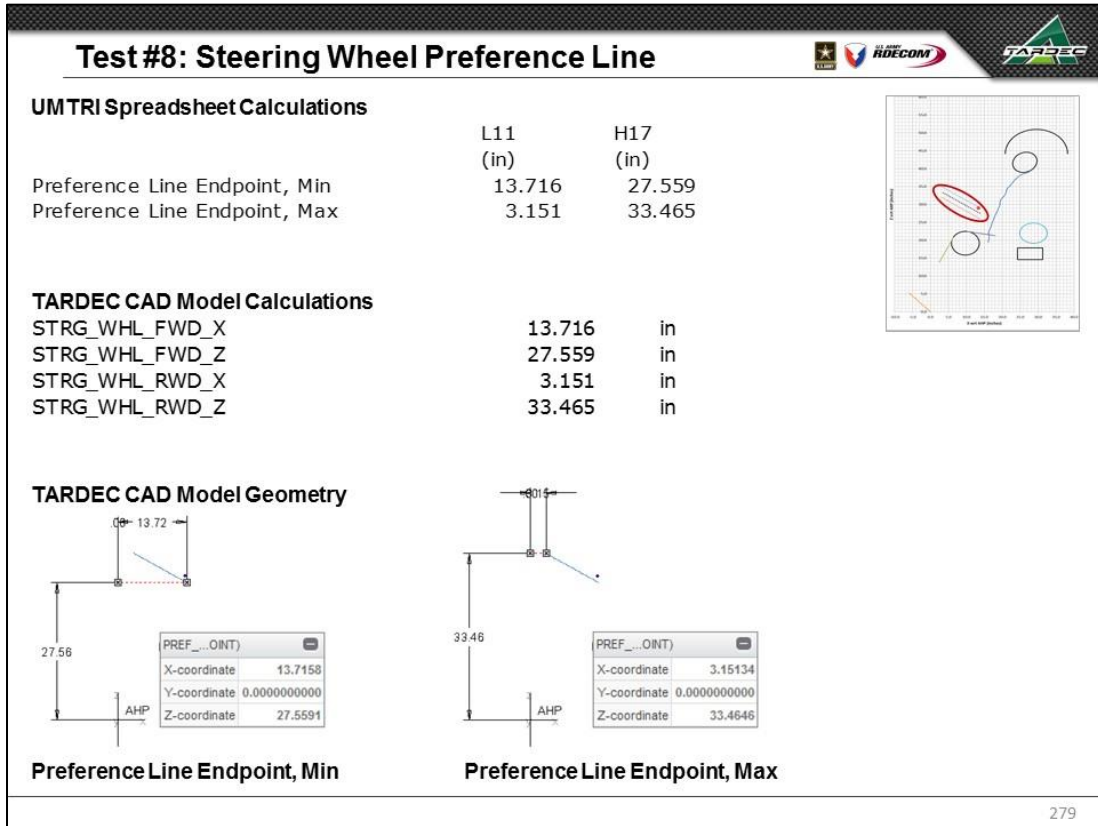

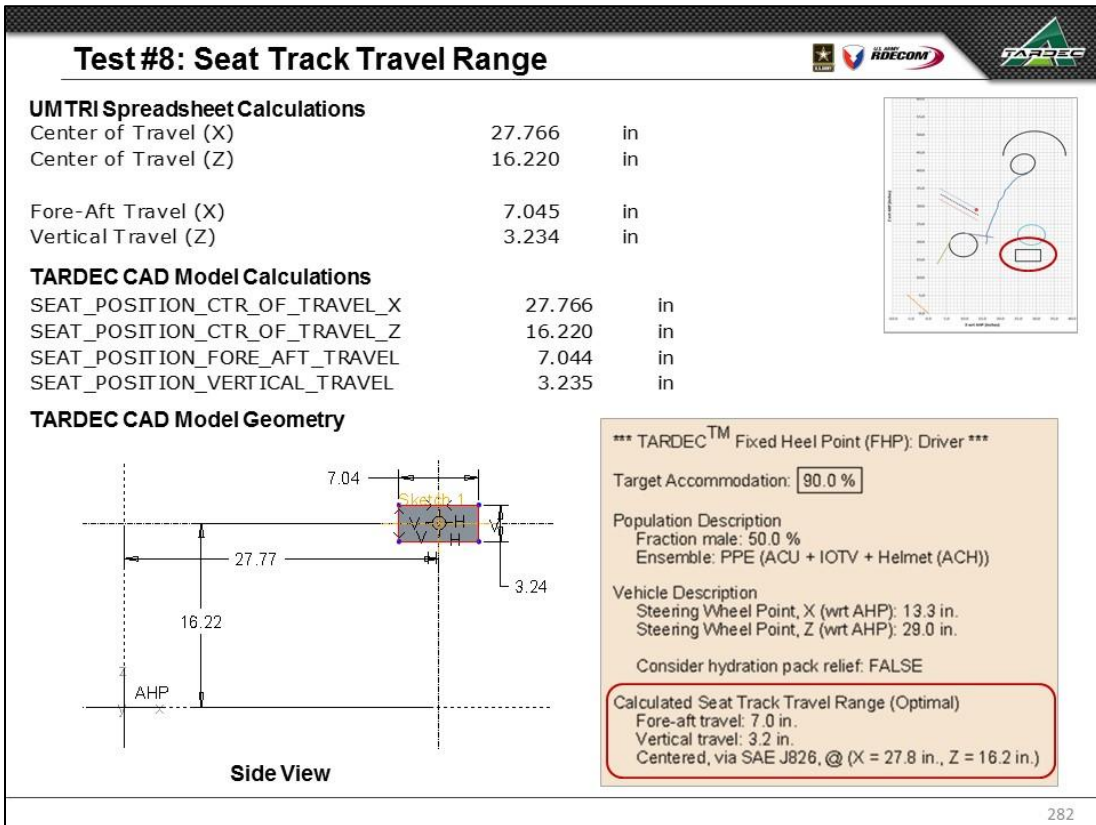
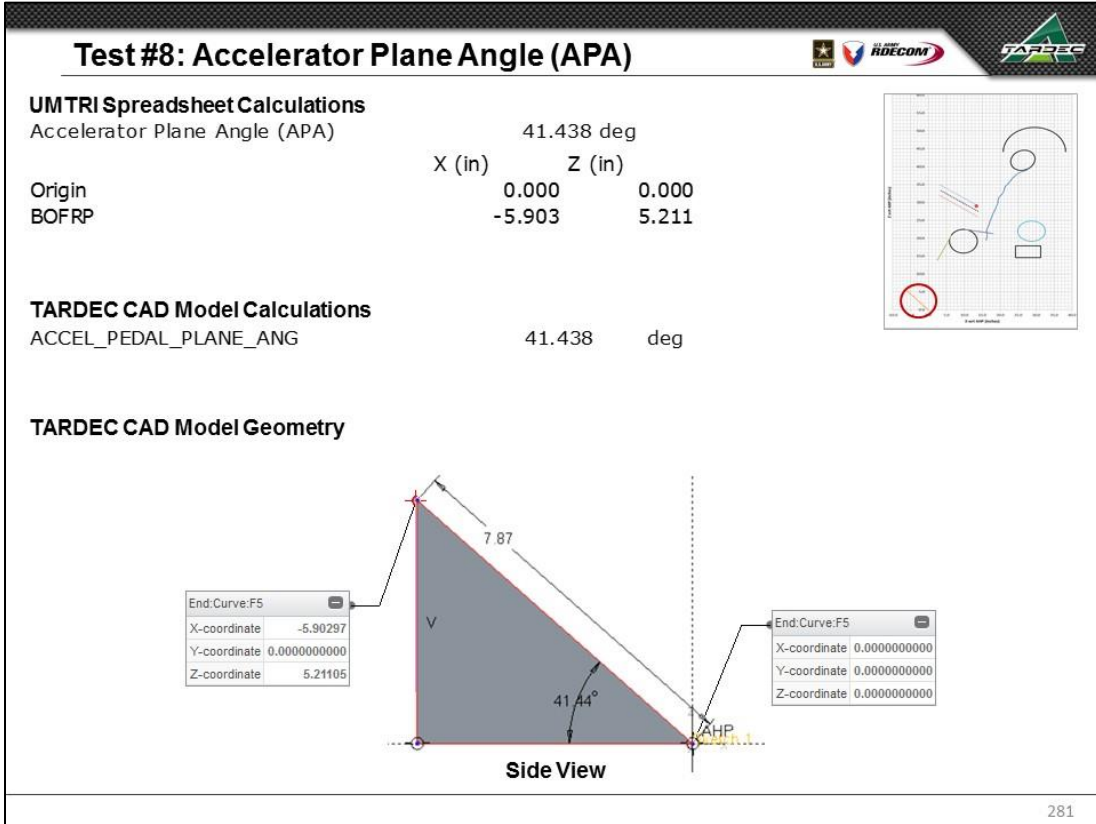

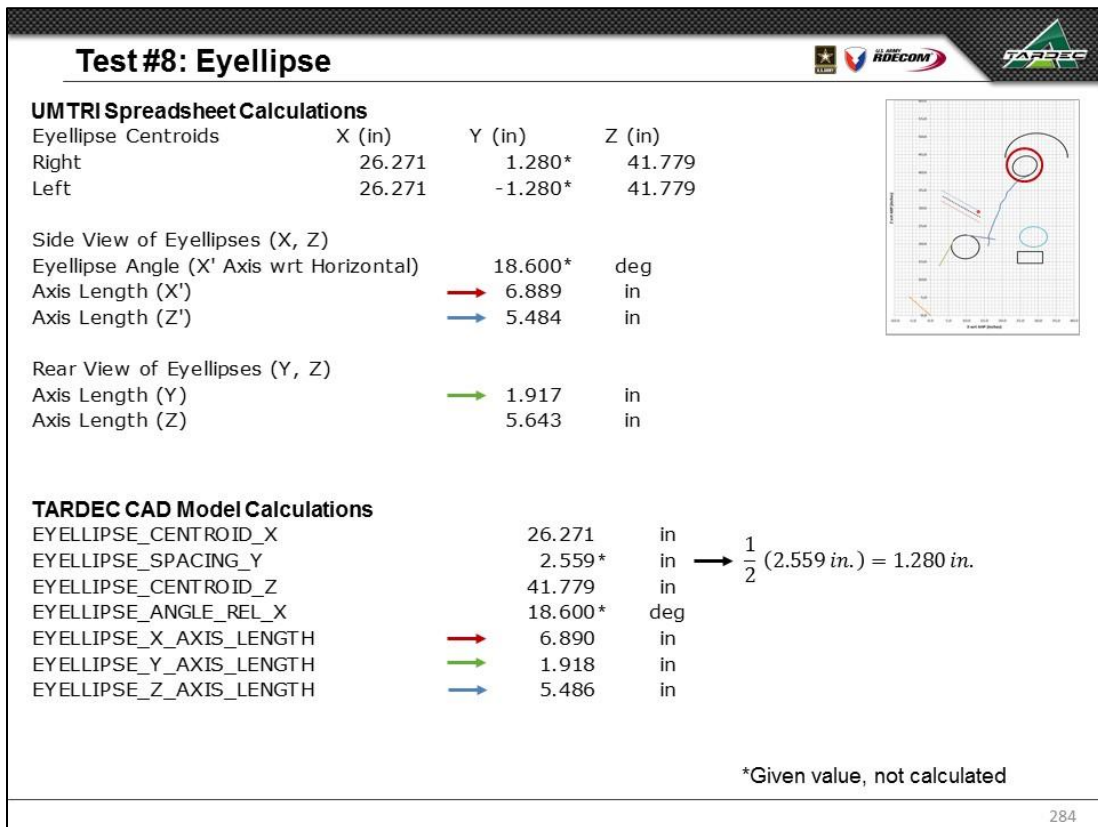
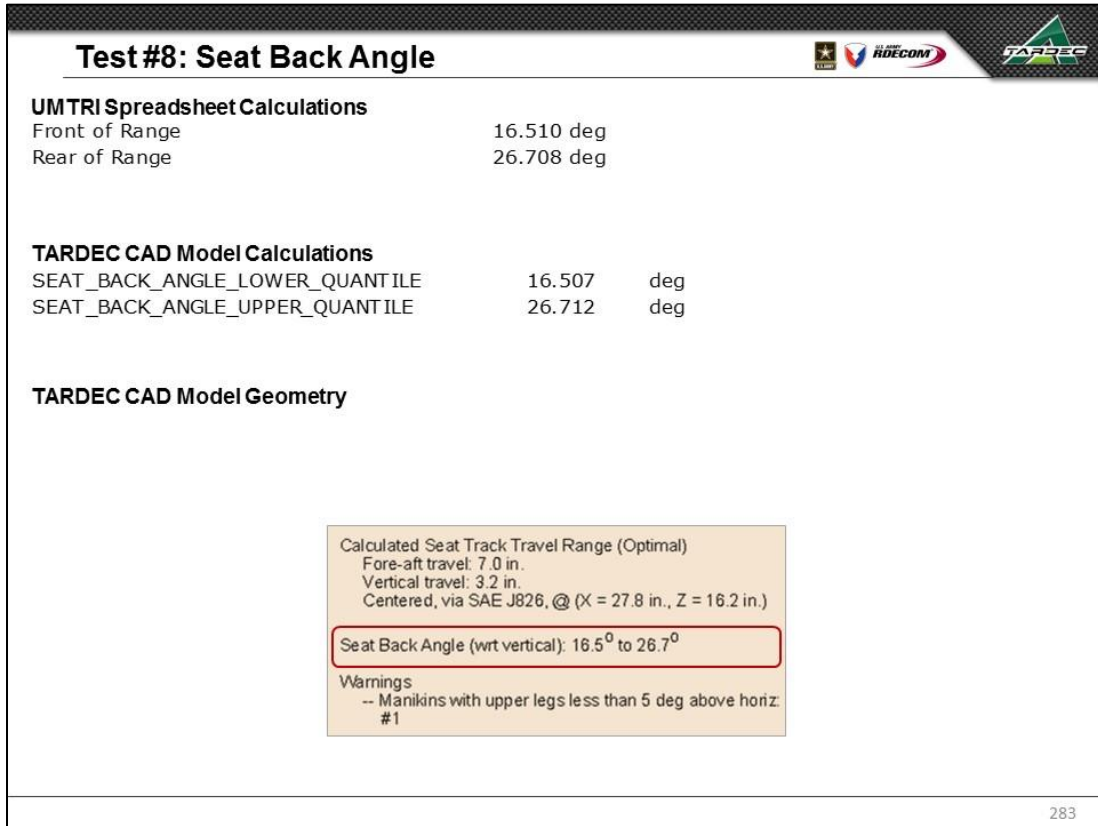

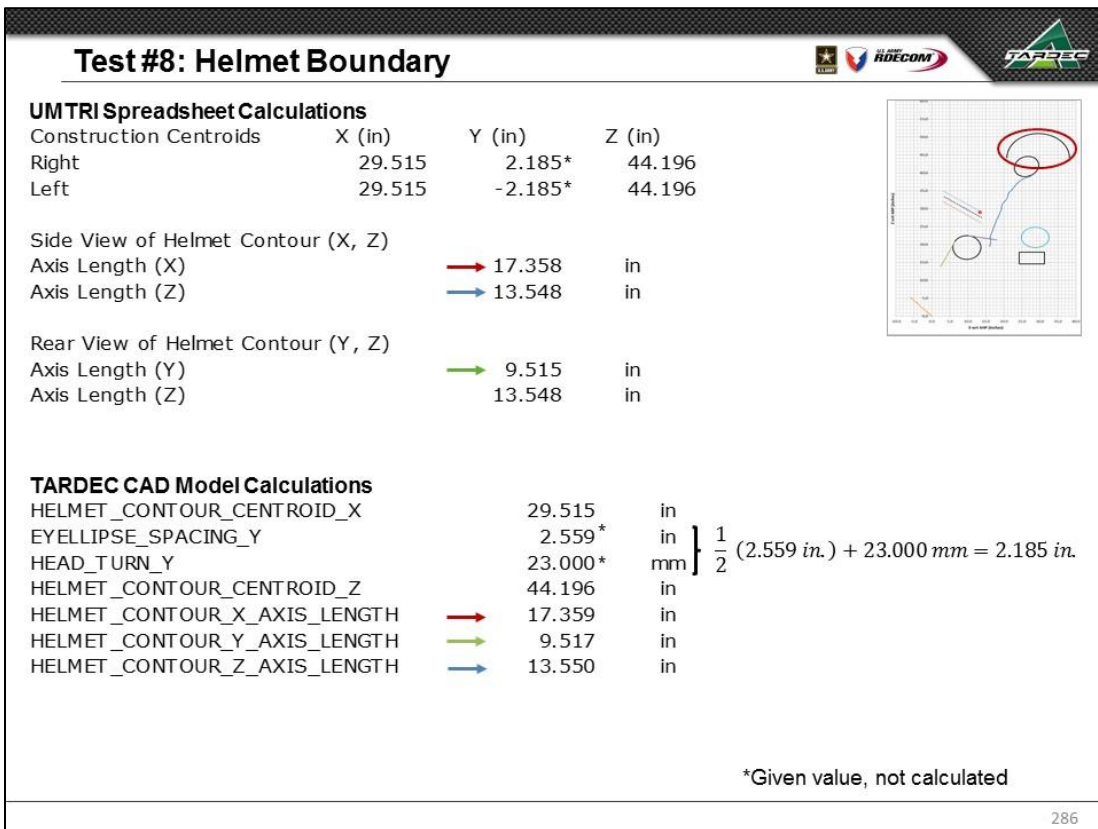
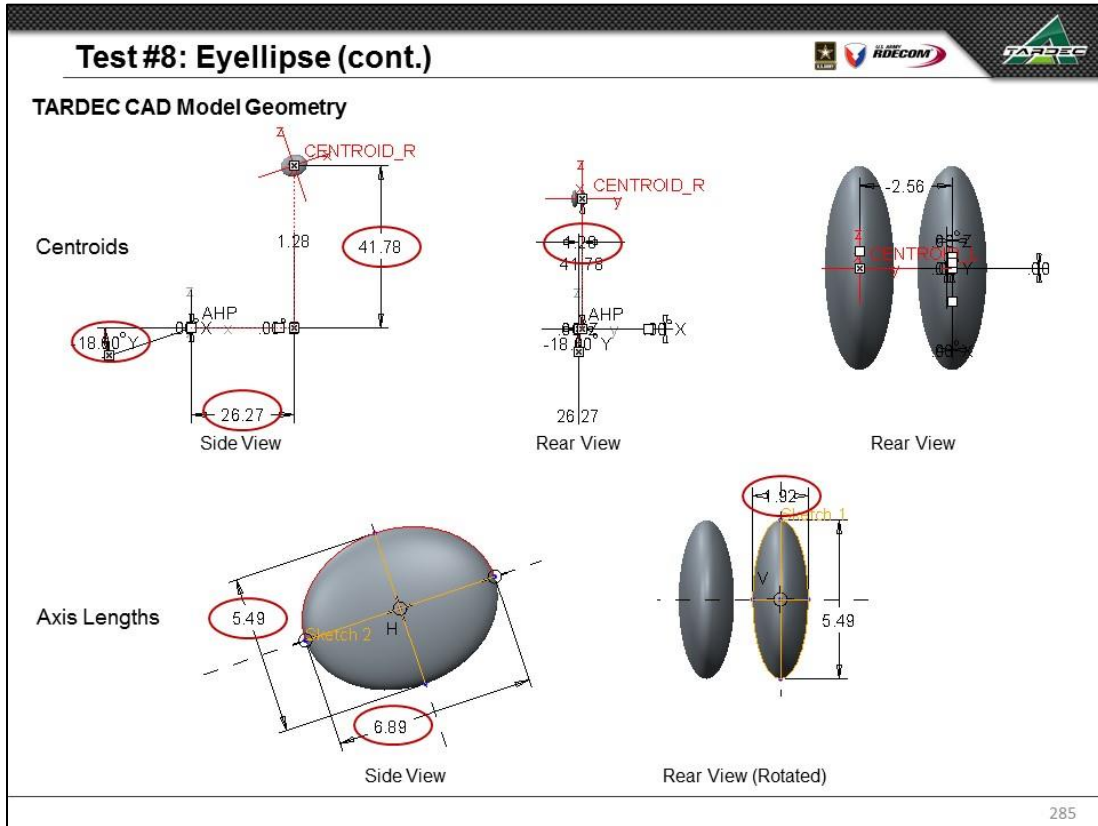

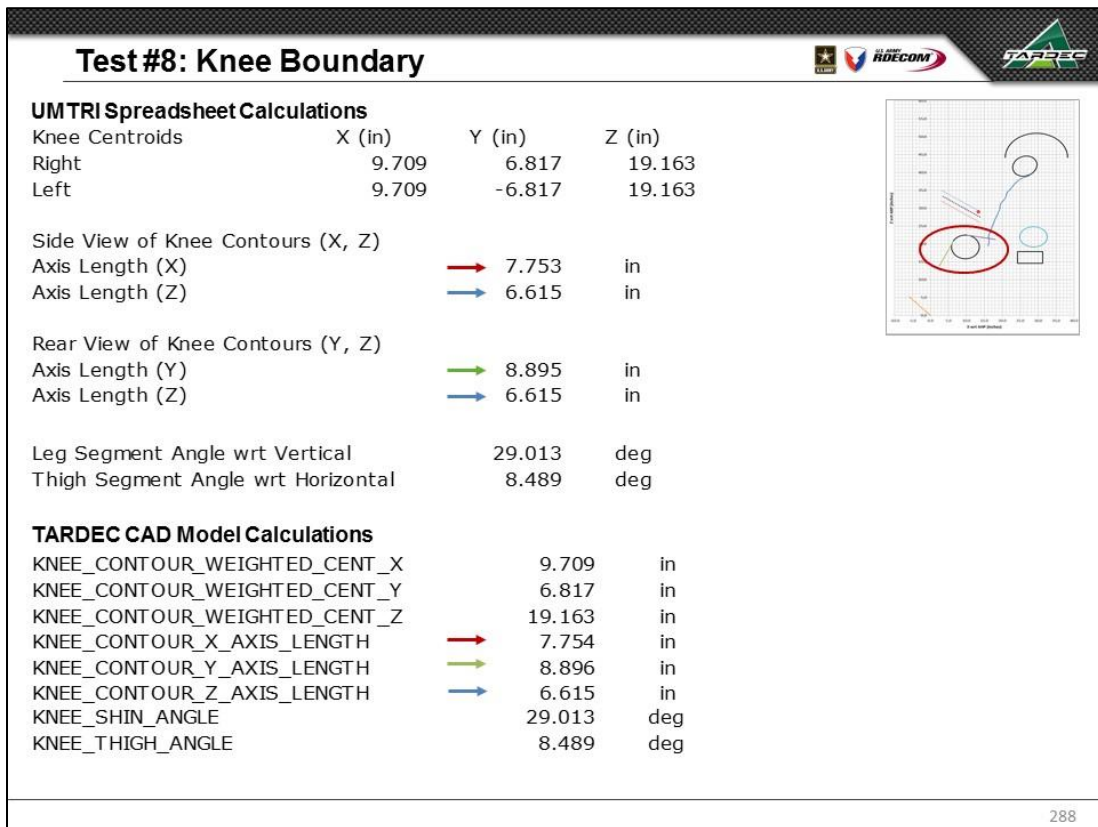
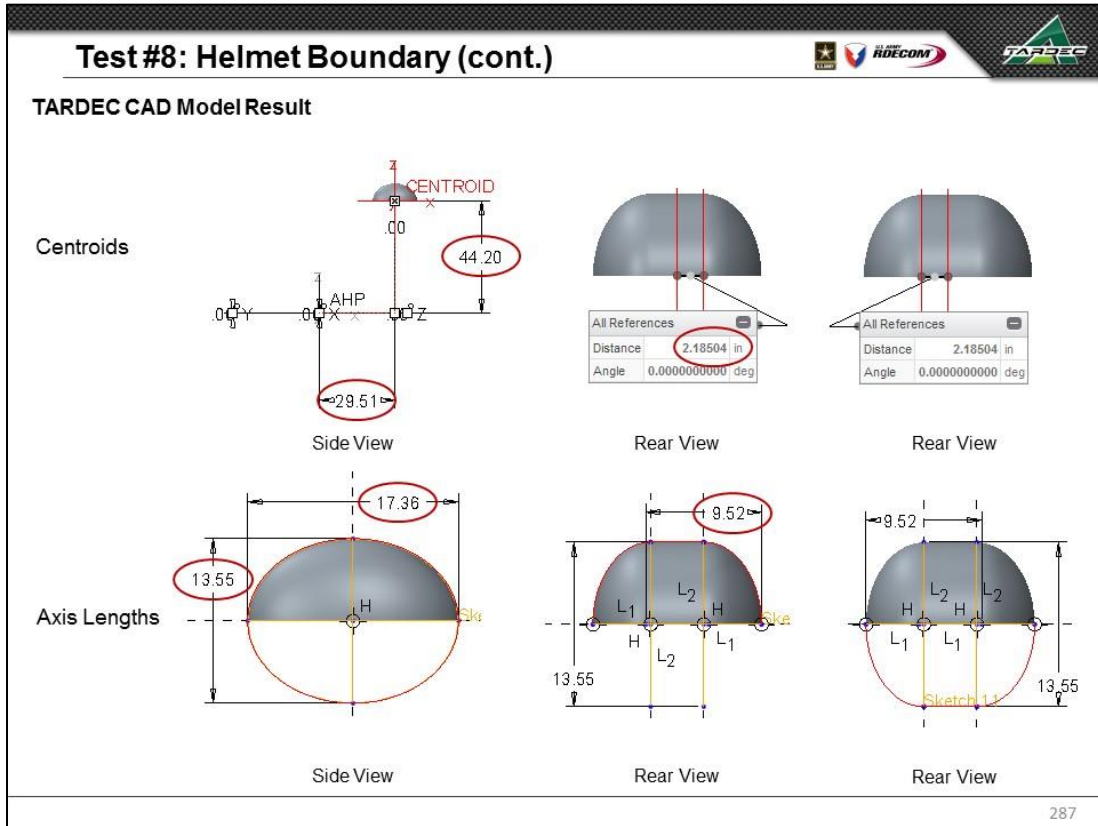

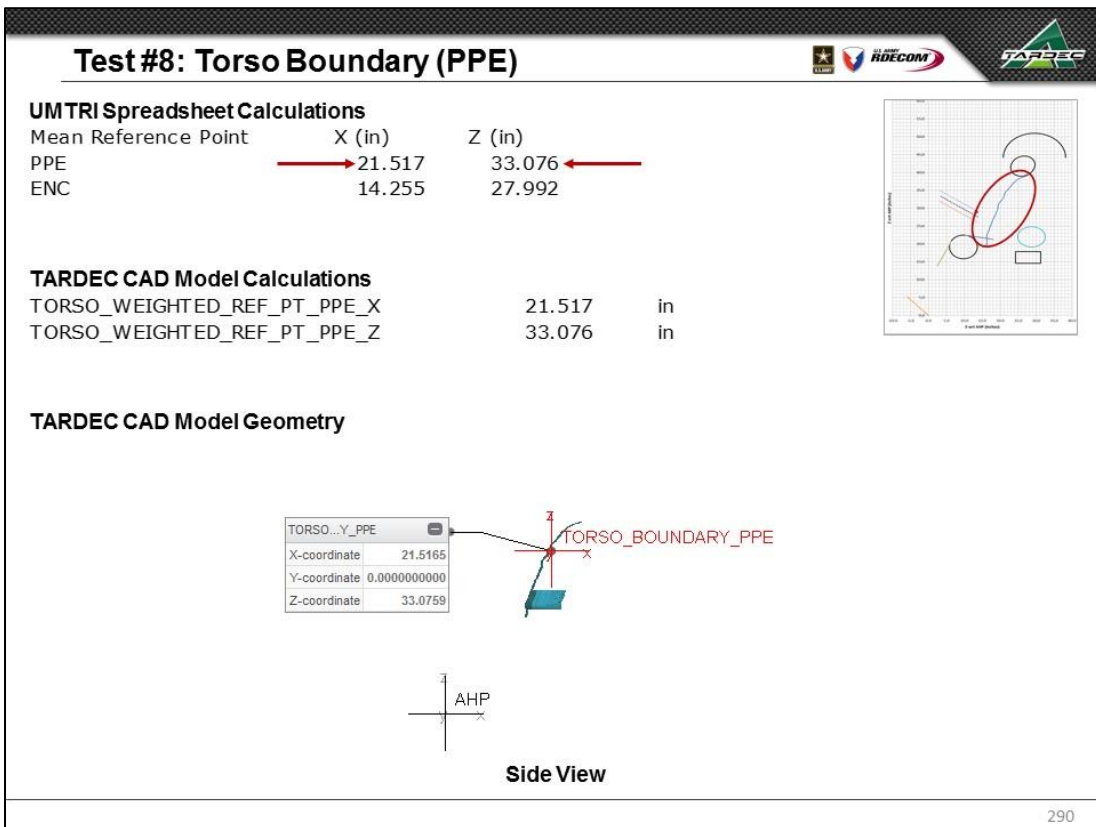
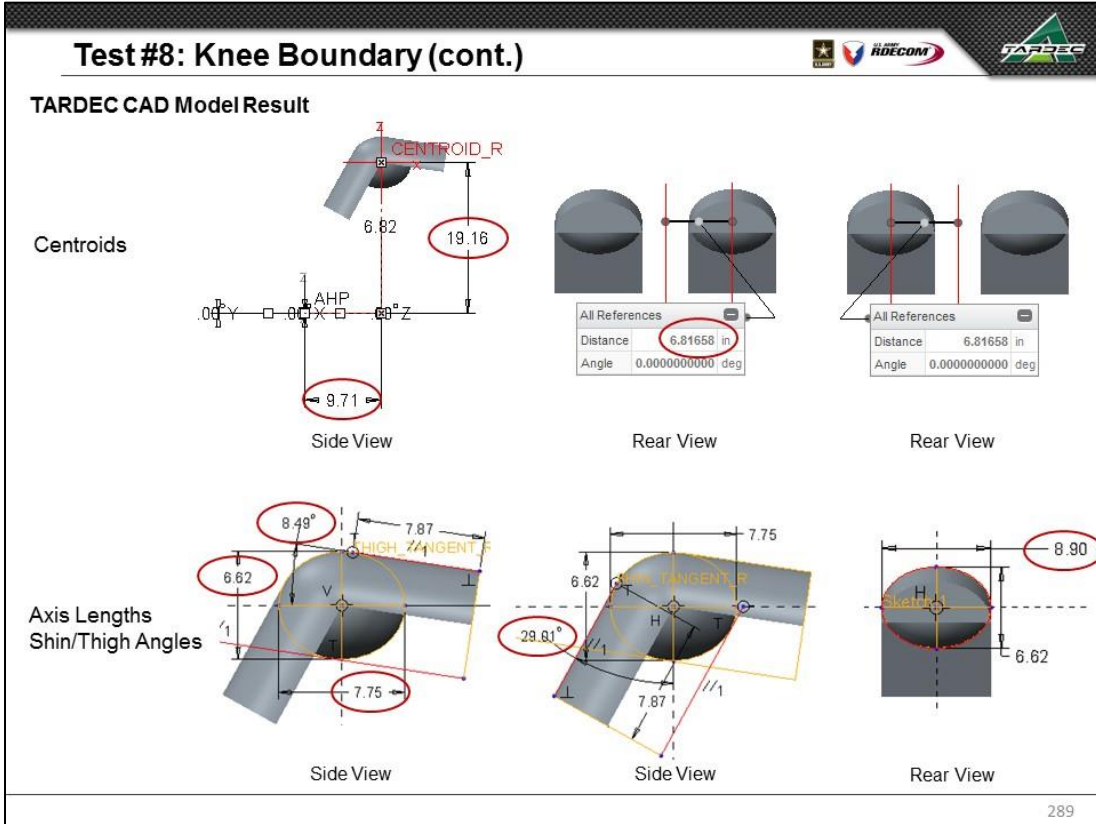

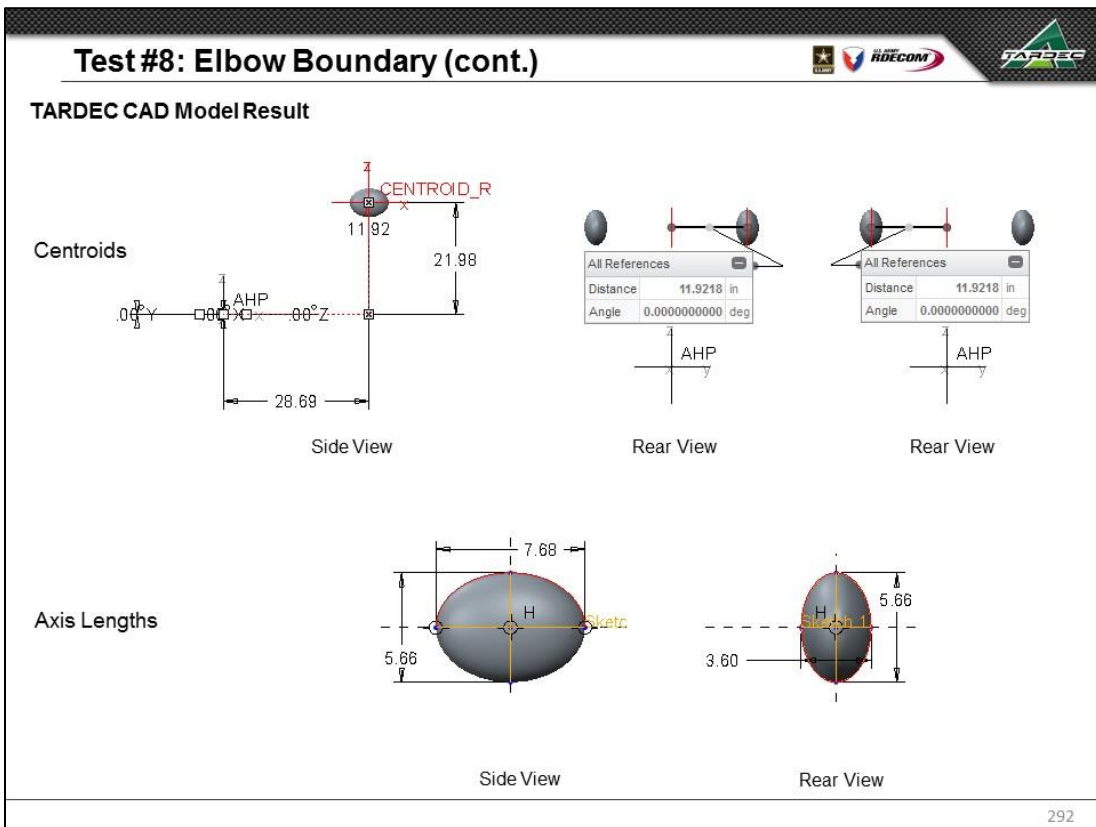
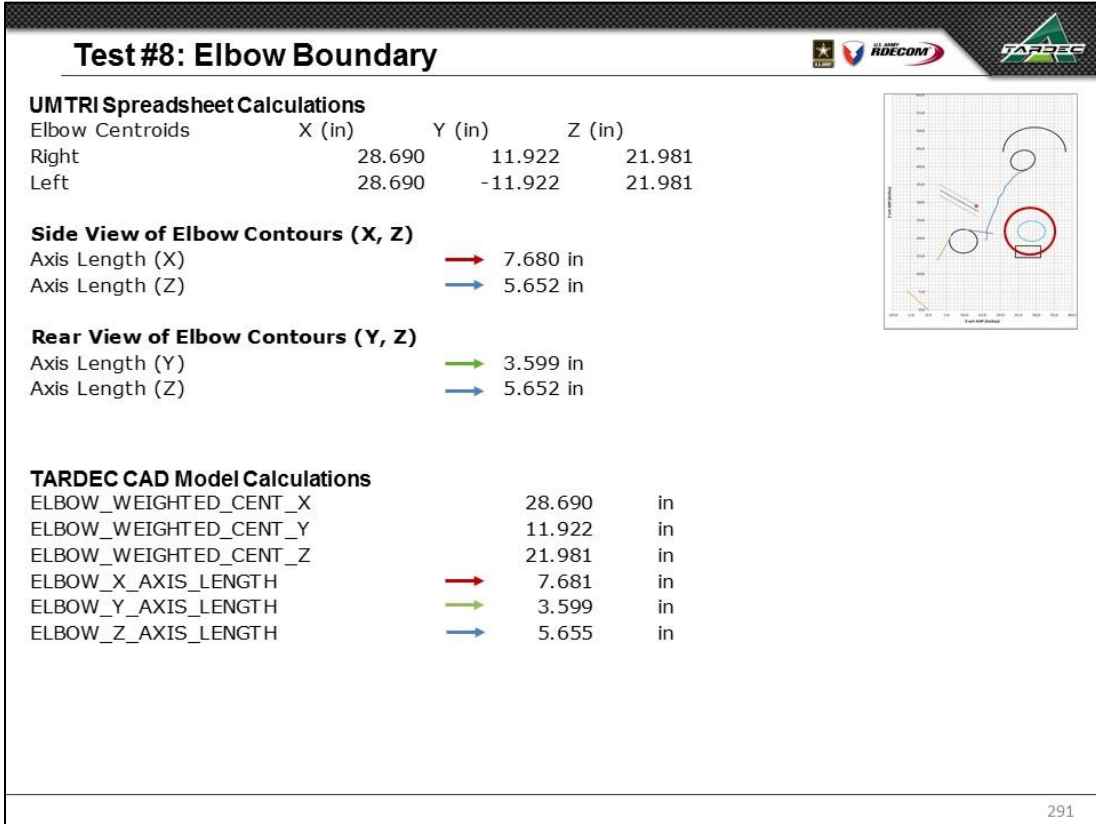

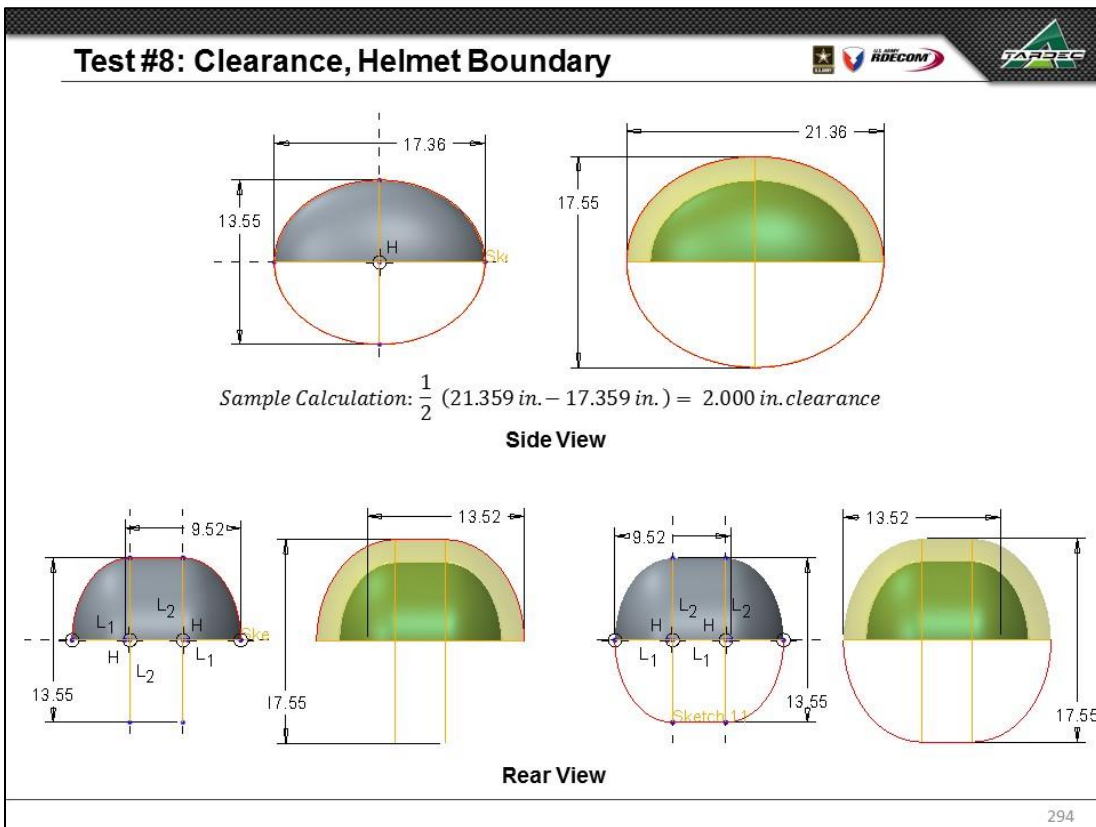
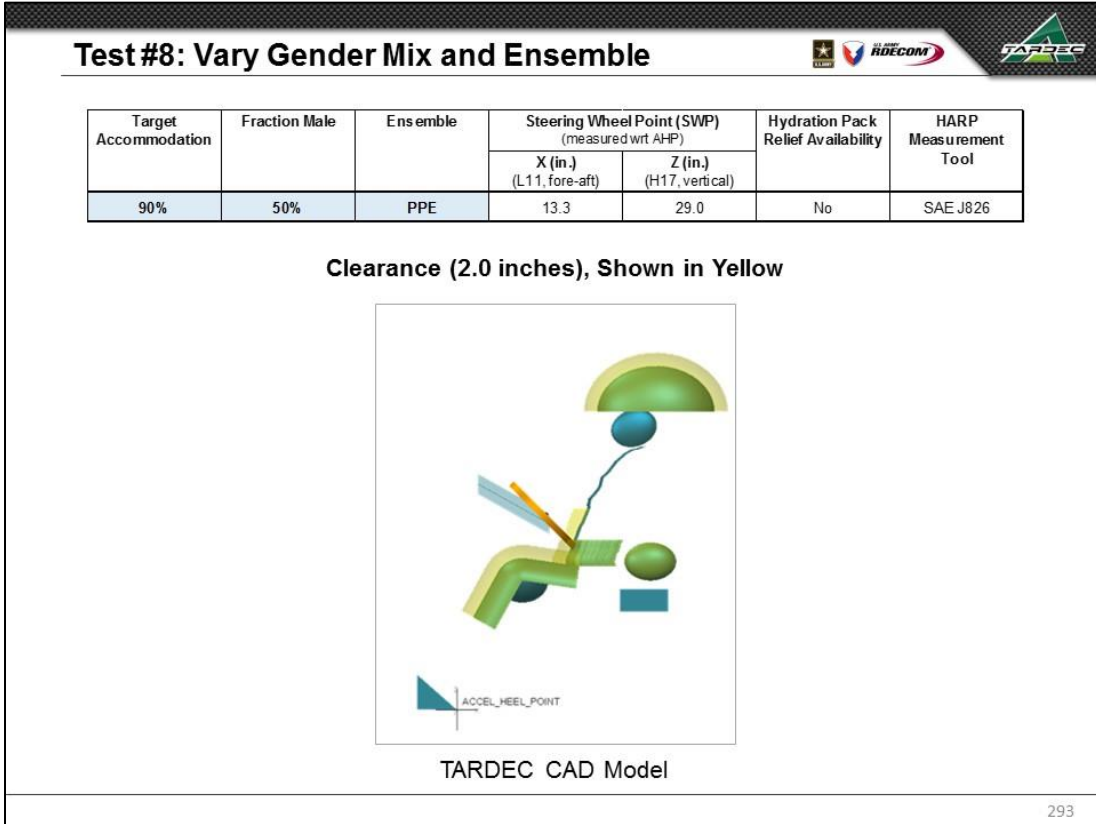

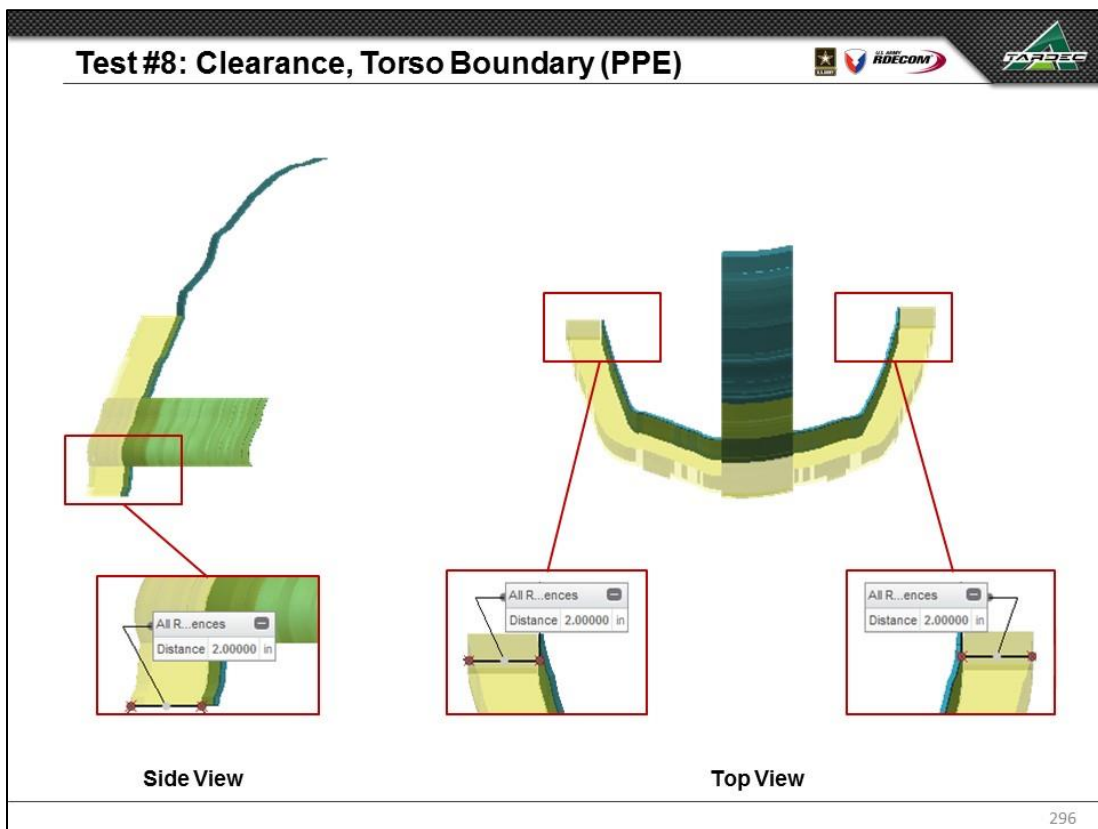
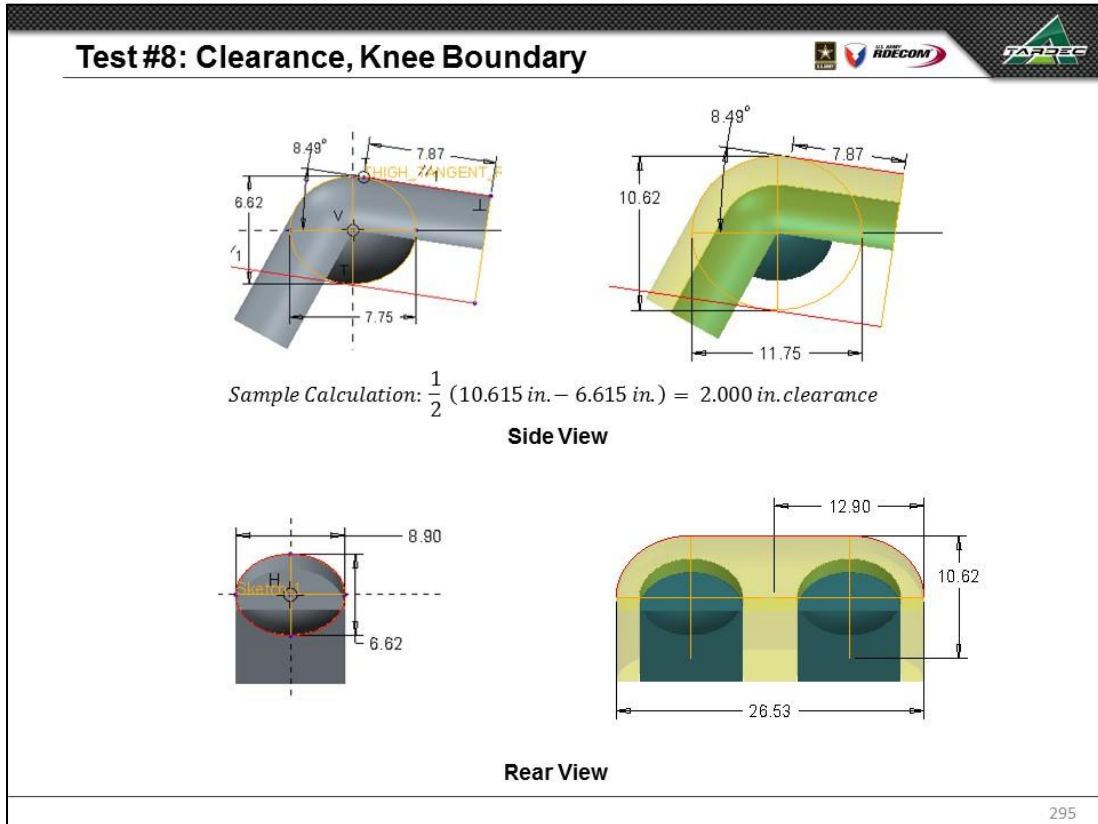

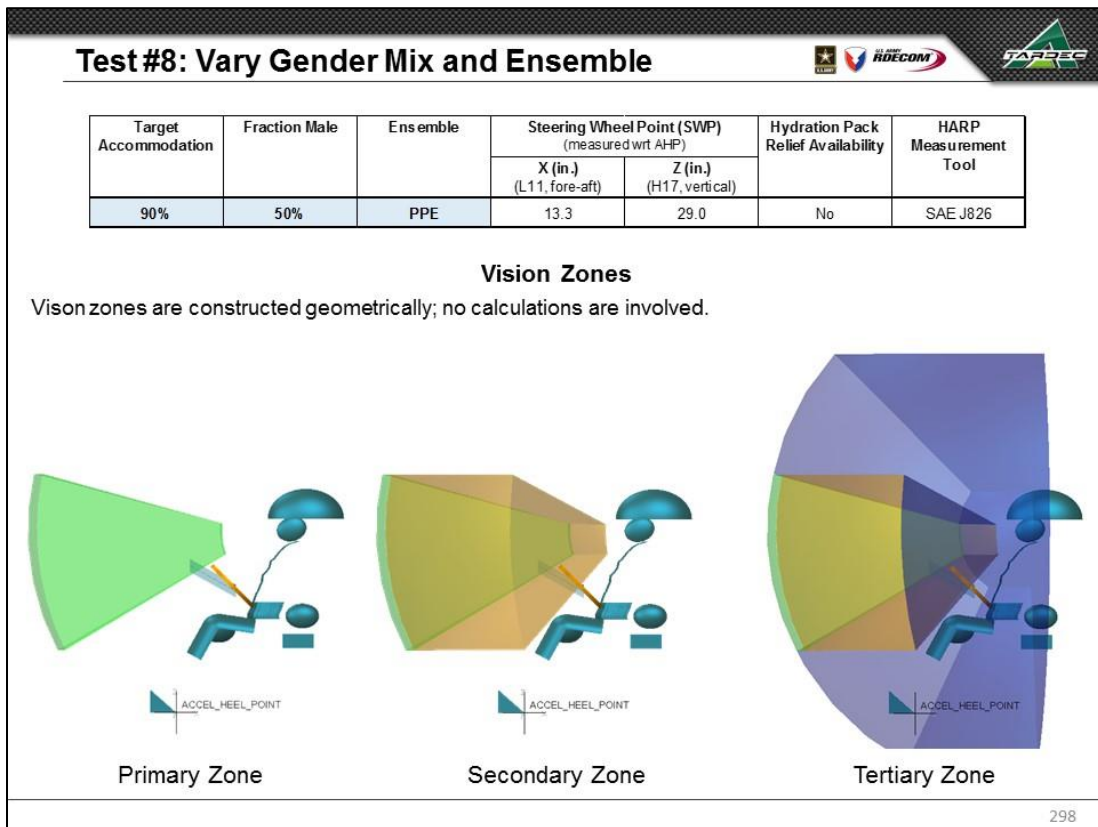
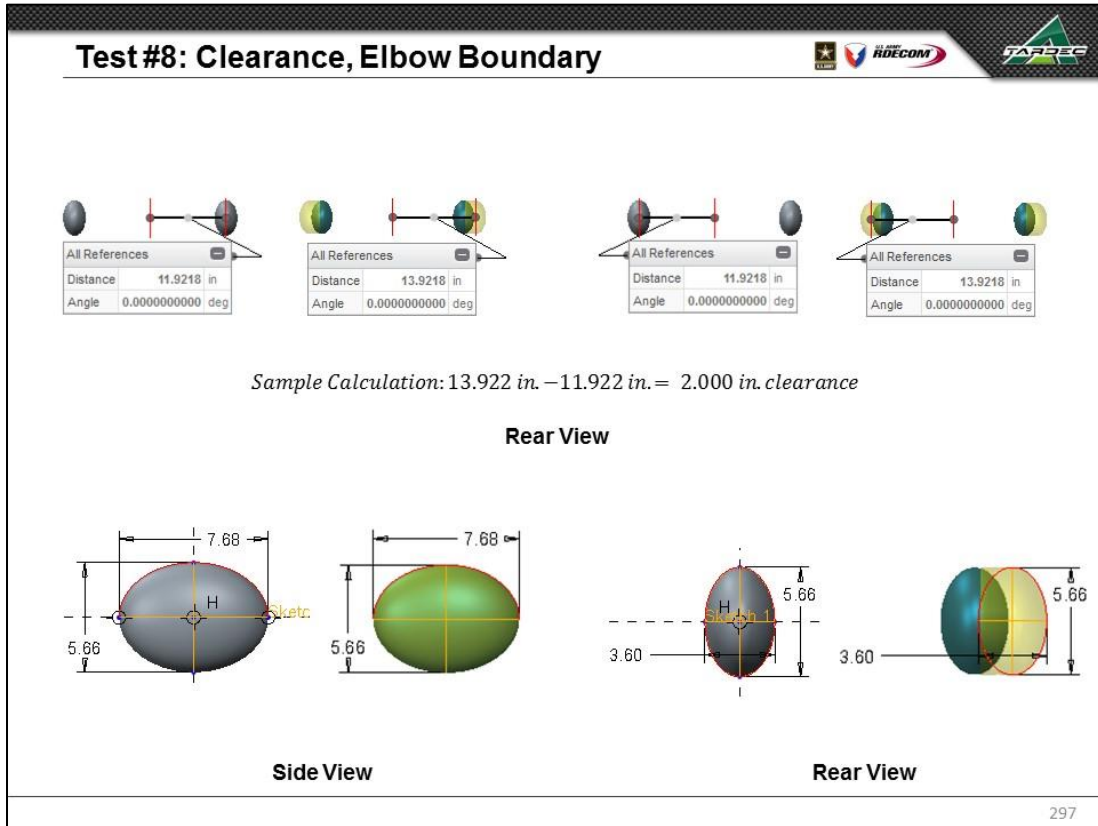

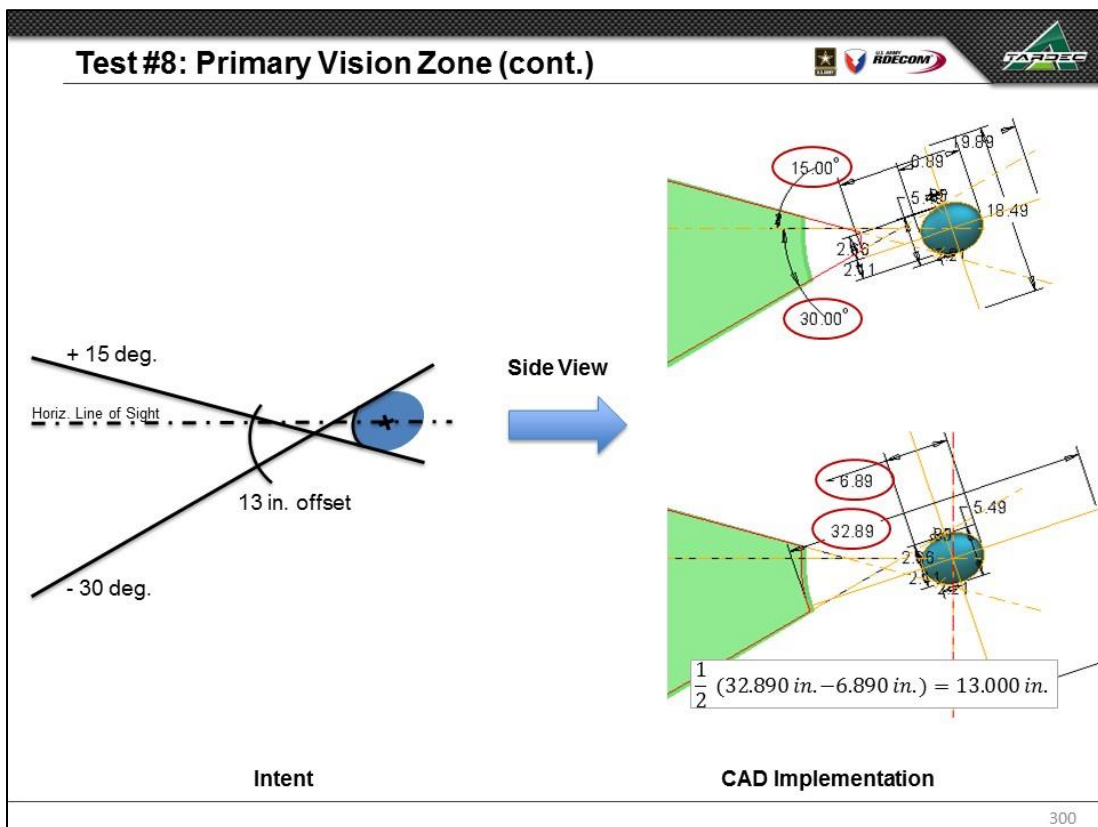
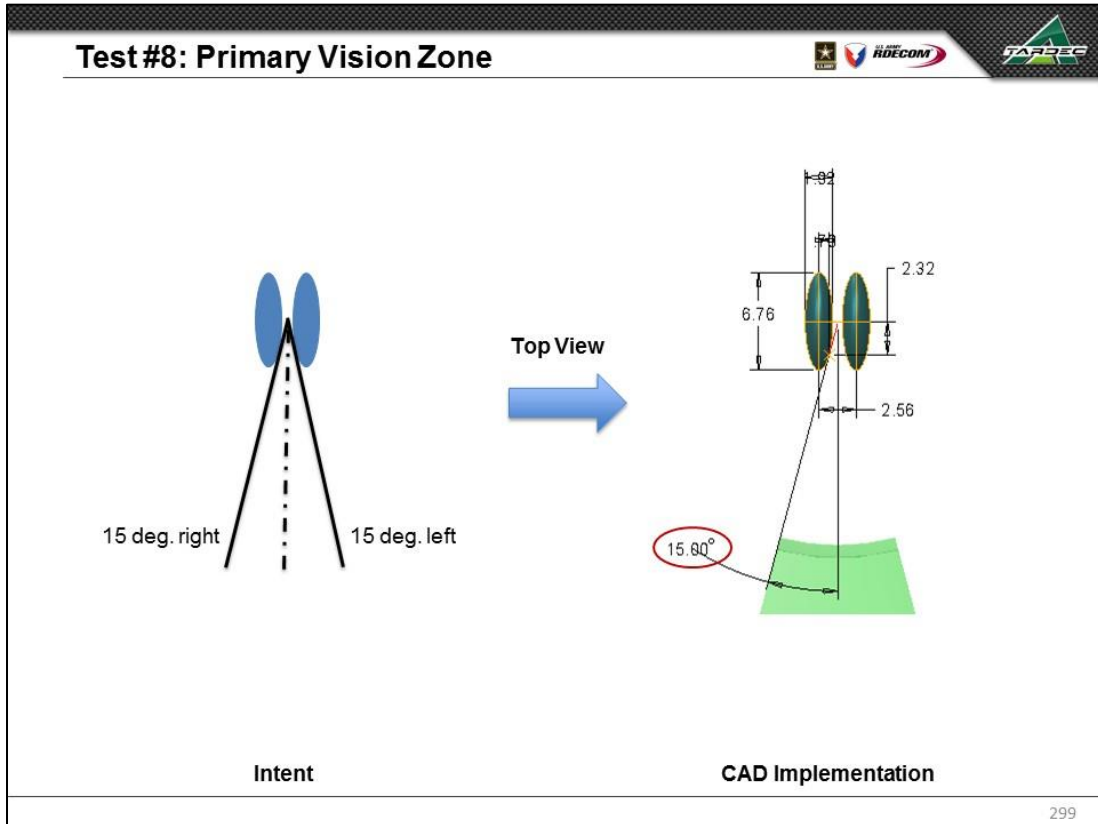

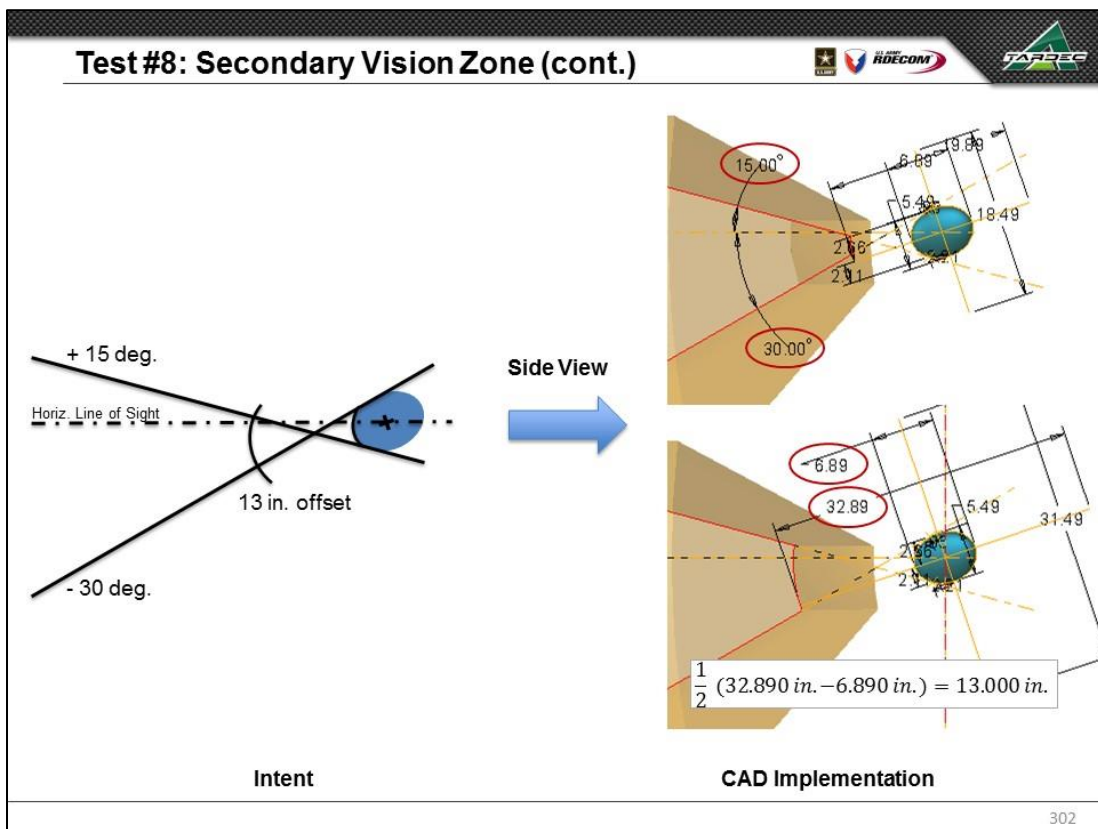
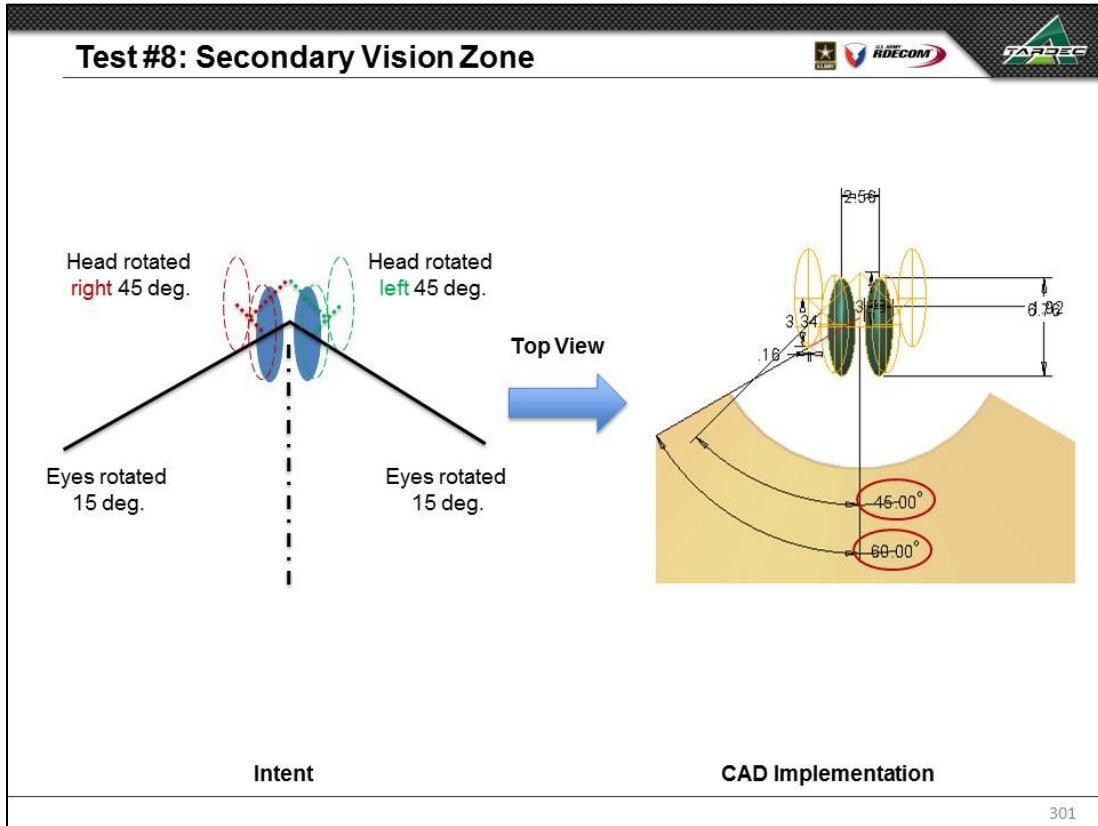

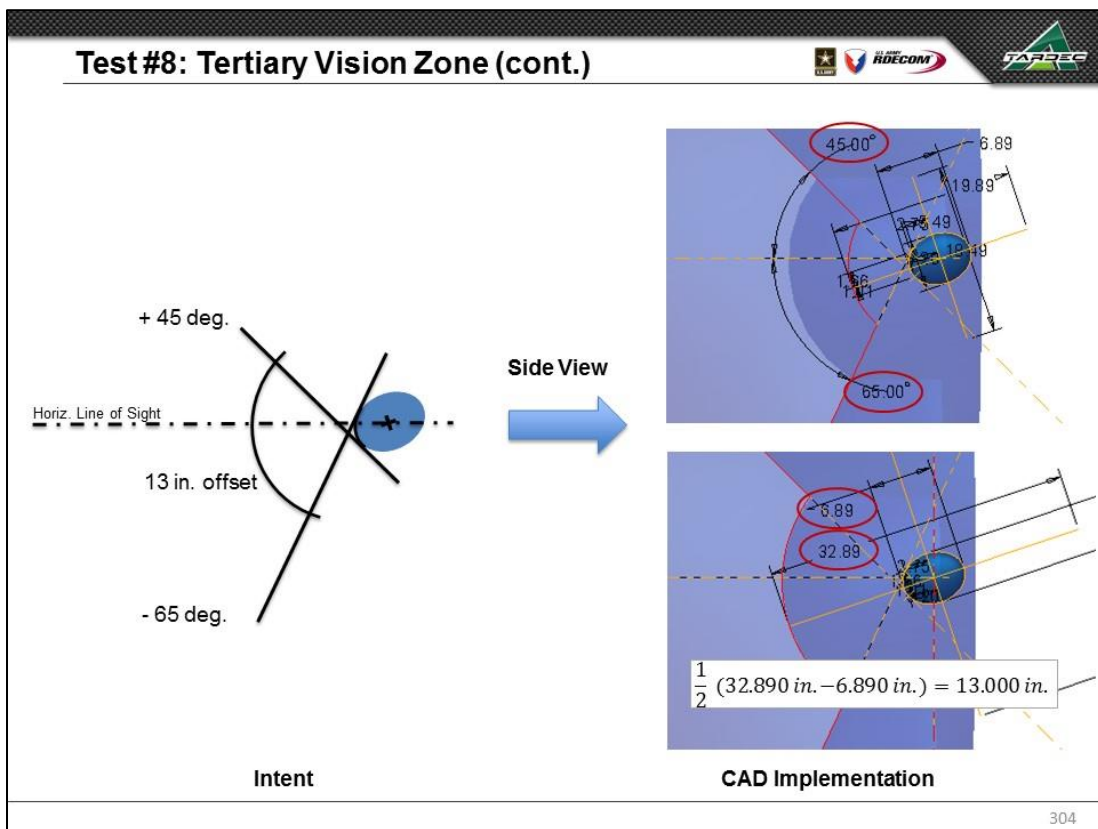
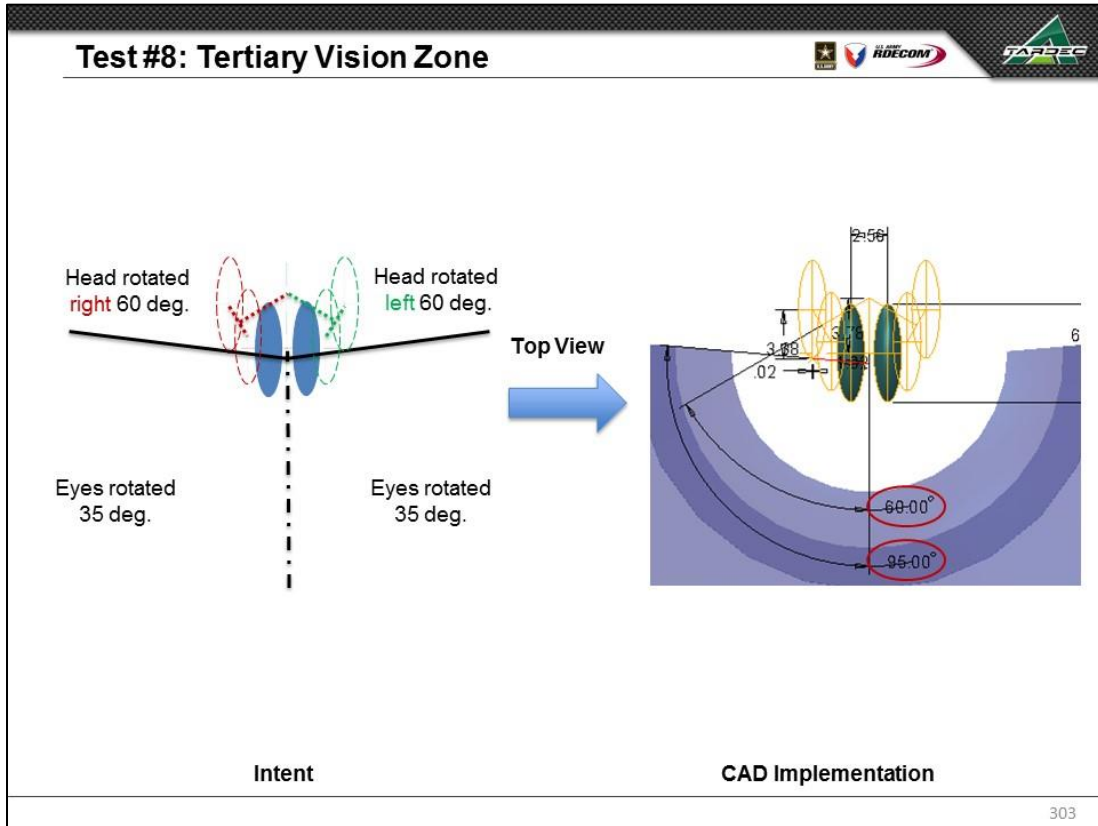



Test #8: Vary Gender Mix and Ensemble



Target Accommodation	Fraction Male	Ensemble	Steering Wheel Point (SWP) (measured wrt AHP)		Hydration Pack Relief Availability	HARP Measurement Tool
			X (in.) (L11, fore-aft)	Z (in.) (H17, vertical)		
90%	50%	PPE	13.3	29.0	No	SAE J826

Boundary Manikin Posture and Position



TARDEC CAD Model

305

Test #8: Numerical Results, Manikin Positioning



Small Overall Female			
	UMTRI Value	TARDEC Value	Difference
POSTURE_DHM1_HIP_X	23.660 in	23.660 in	0.000 in
POSTURE_DHM1_HIP_Z	15.879 in	15.879 in	0.000 in
POSTURE_DHM1_EYE_X	24.940 in	24.940 in	0.000 in
POSTURE_DHM1_EYE_Z	38.171 in	38.171 in	0.000 in
Small Overall Male			
	UMTRI Value	TARDEC Value	Difference
POSTURE_DHM2_HIP_X	25.782 in	25.782 in	0.000 in
POSTURE_DHM2_HIP_Z	15.989 in	15.989 in	0.000 in
POSTURE_DHM2_EYE_X	26.191 in	26.191 in	0.000 in
POSTURE_DHM2_EYE_Z	39.938 in	39.938 in	0.000 in
Average Size Male			
	UMTRI Value	TARDEC Value	Difference
POSTURE_DHM3_HIP_X	27.977 in	27.977 in	0.000 in
POSTURE_DHM3_HIP_Z	15.988 in	15.988 in	0.000 in
POSTURE_DHM3_EYE_X	27.599 in	27.599 in	0.000 in
POSTURE_DHM3_EYE_Z	42.162 in	42.162 in	0.000 in
Widest Shoulders Male			
	UMTRI Value	TARDEC Value	Difference
POSTURE_DHM4_HIP_X	28.985 in	28.986 in	0.000 in
POSTURE_DHM4_HIP_Z	15.977 in	15.977 in	0.000 in
POSTURE_DHM4_EYE_X	28.255 in	28.256 in	0.000 in
POSTURE_DHM4_EYE_Z	43.440 in	43.440 in	0.000 in
Longest Torso Male			
	UMTRI Value	TARDEC Value	Difference
POSTURE_DHM5_HIP_X	28.229 in	28.229 in	0.000 in
POSTURE_DHM5_HIP_Z	15.971 in	15.971 in	0.000 in
POSTURE_DHM5_EYE_X	27.765 in	27.765 in	0.000 in
POSTURE_DHM5_EYE_Z	44.441 in	44.441 in	0.000 in
Longest Legs Male			
	UMTRI Value	TARDEC Value	Difference
POSTURE_DHM6_HIP_X	30.501 in	30.502 in	0.000 in
POSTURE_DHM6_HIP_Z	16.042 in	16.042 in	0.000 in
POSTURE_DHM6_EYE_X	29.176 in	29.176 in	0.000 in
POSTURE_DHM6_EYE_Z	42.661 in	42.661 in	0.000 in
Large Overall Male			
	UMTRI Value	TARDEC Value	Difference
POSTURE_DHM7_HIP_X	30.327 in	30.327 in	0.000 in
POSTURE_DHM7_HIP_Z	16.139 in	16.139 in	0.000 in
POSTURE_DHM7_EYE_X	28.932 in	28.932 in	0.000 in
POSTURE_DHM7_EYE_Z	44.400 in	44.400 in	0.000 in

TARDEC CAD values to agree with UMTRI spreadsheet values within
 ±0.100 inches
 ±0.100 degrees

Largest Observed Differences:
 0.000 inches

Values in agreement

306

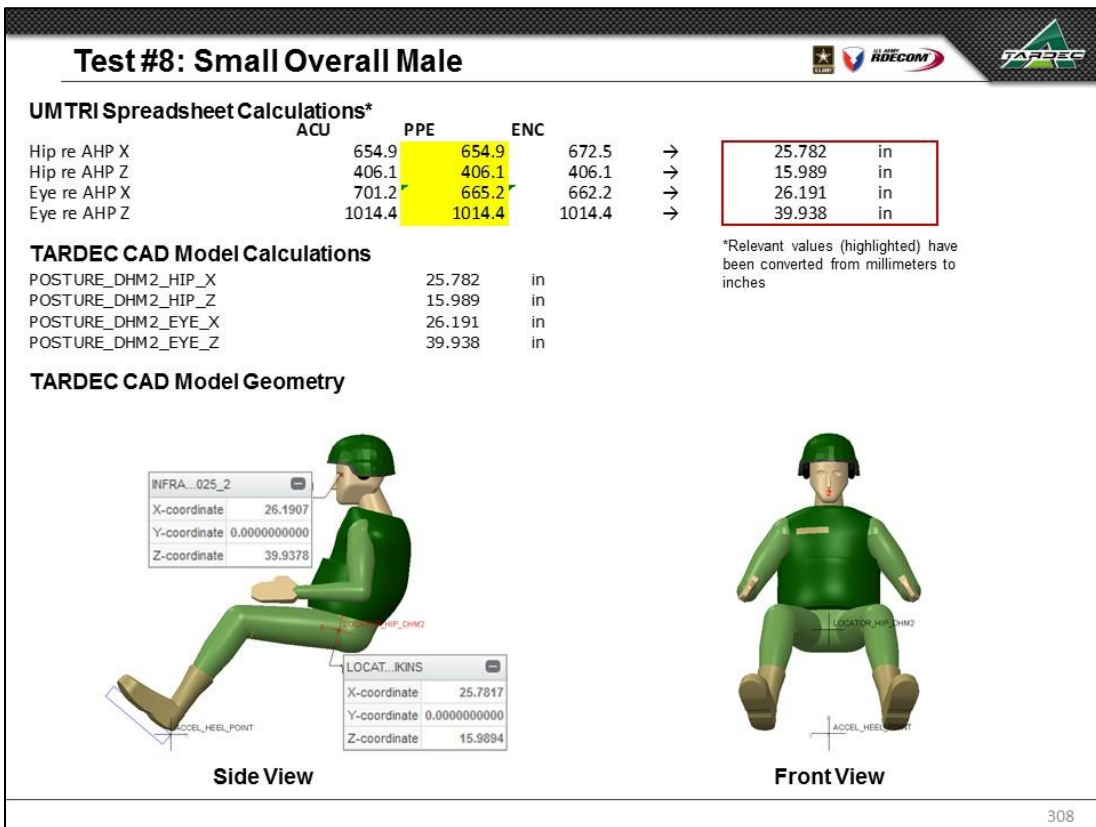
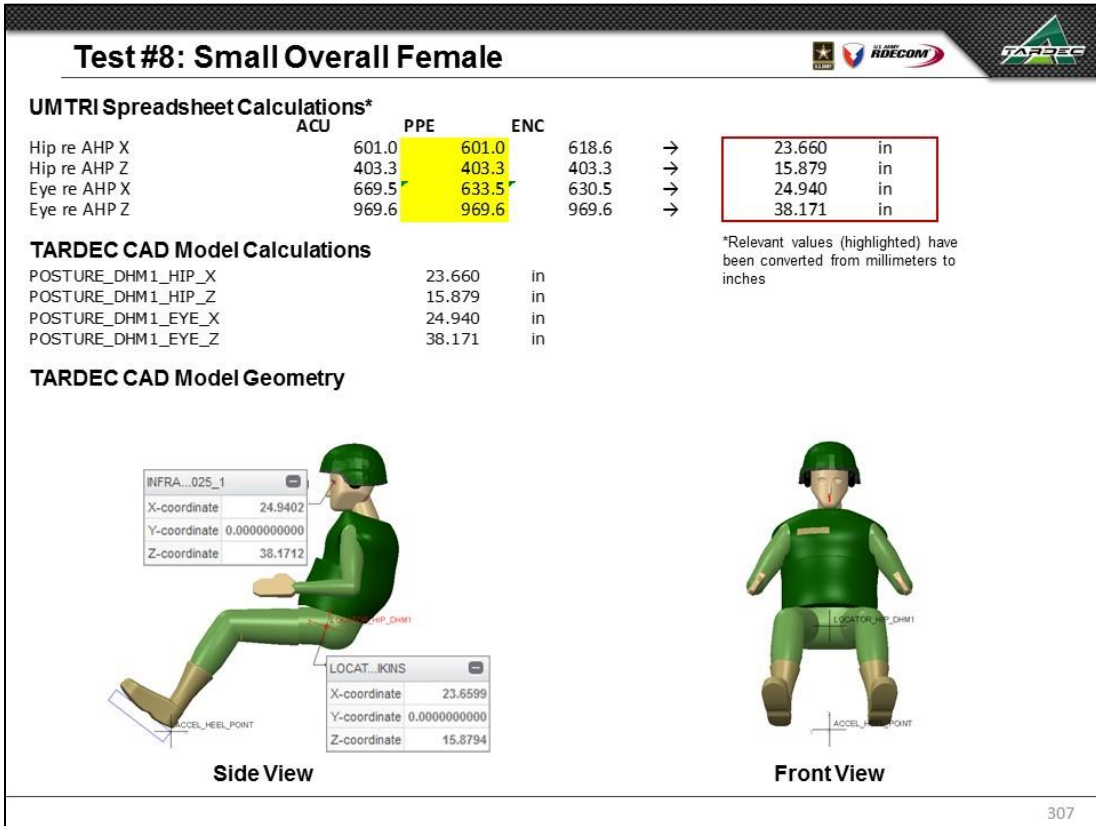

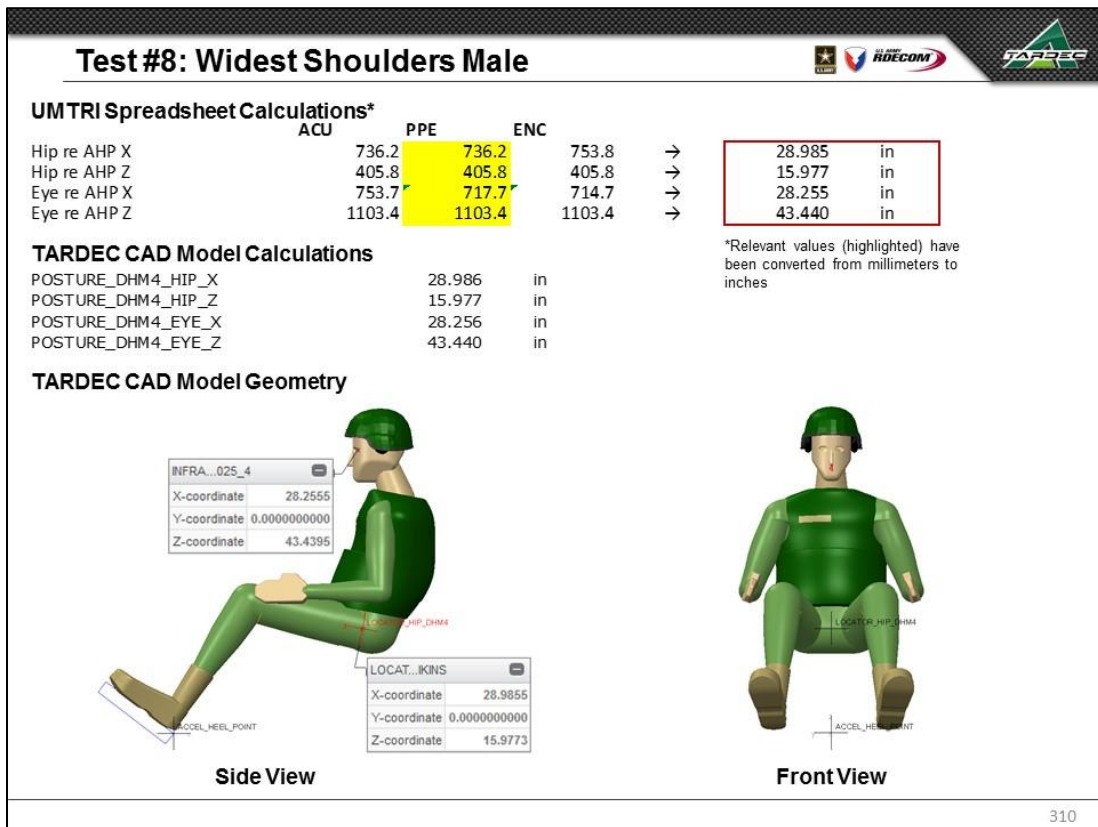
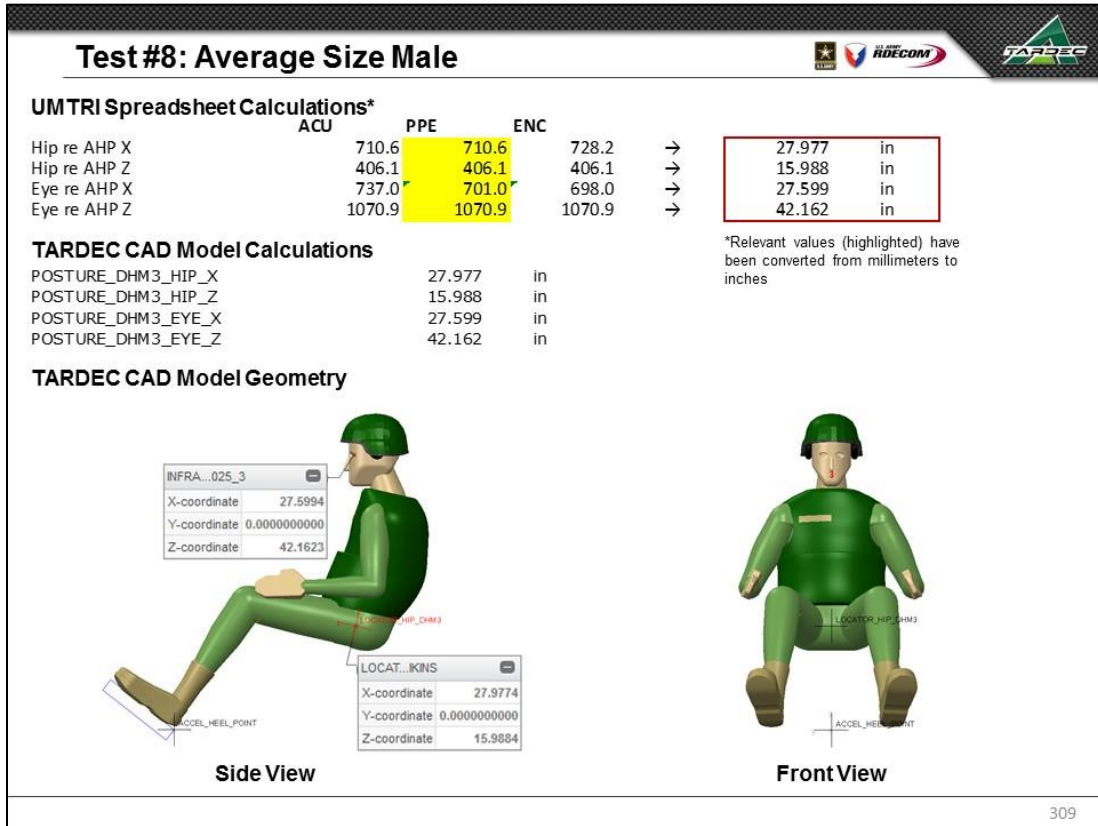

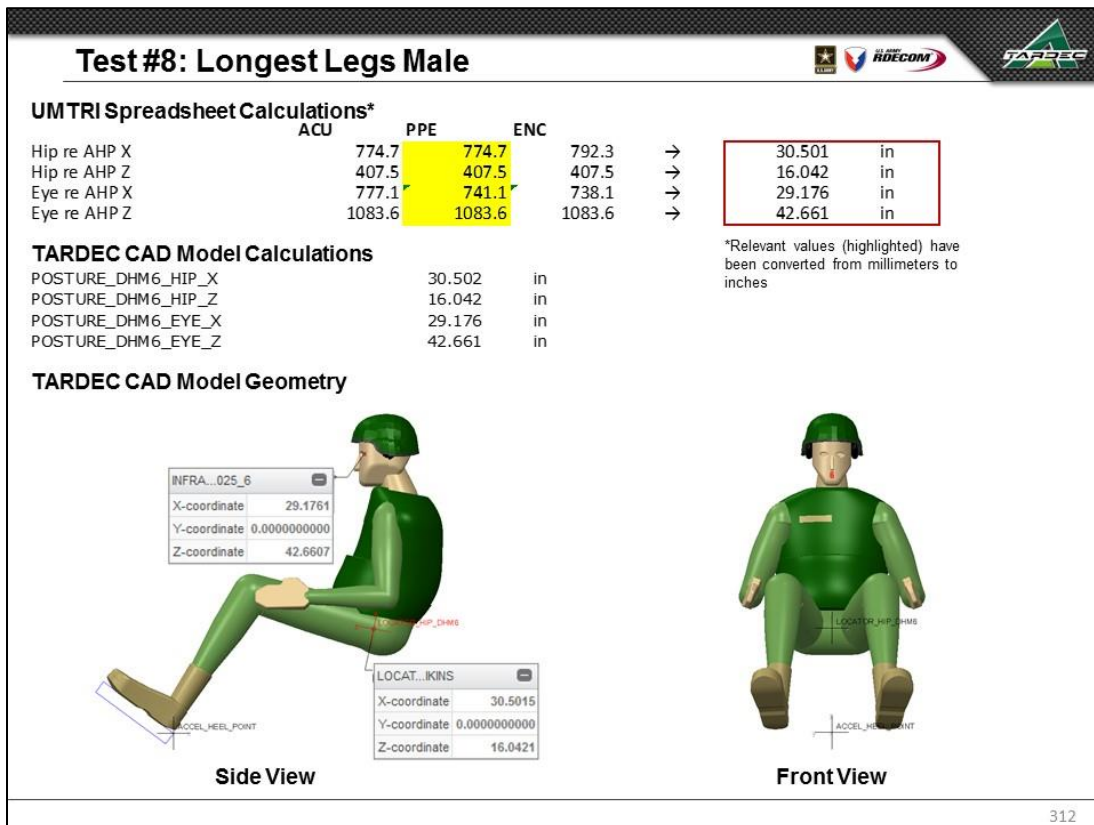
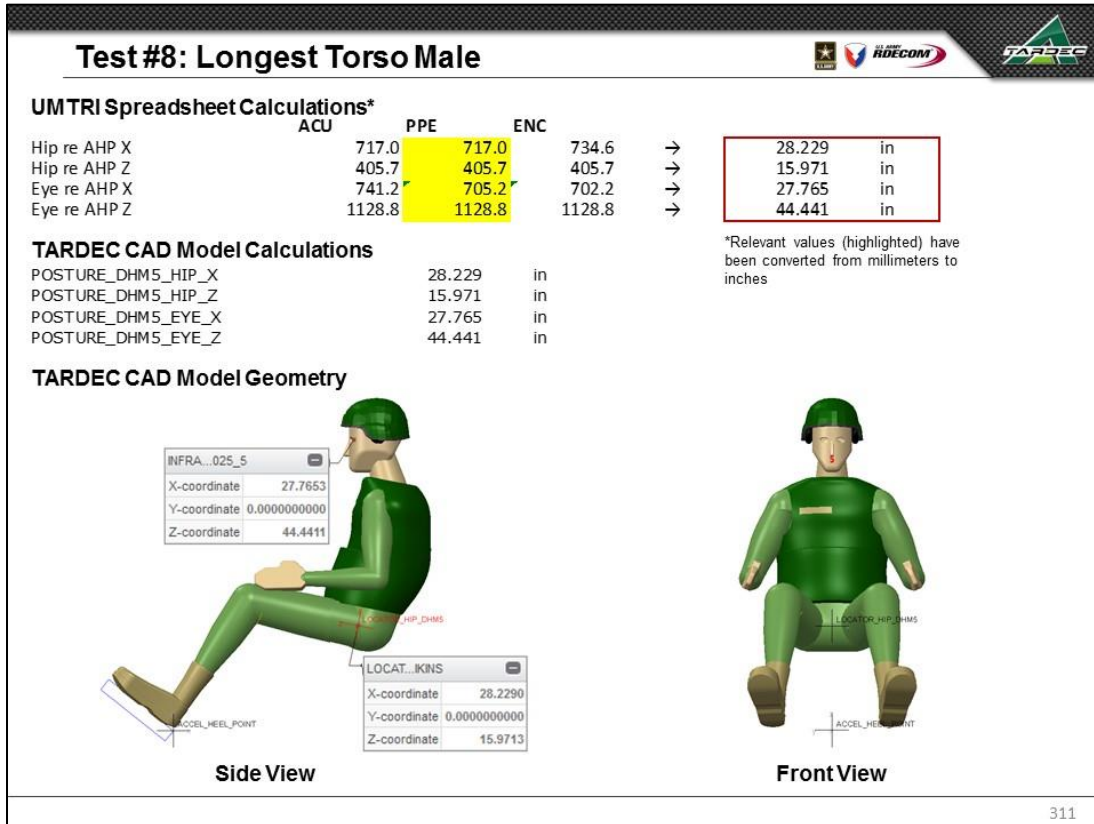

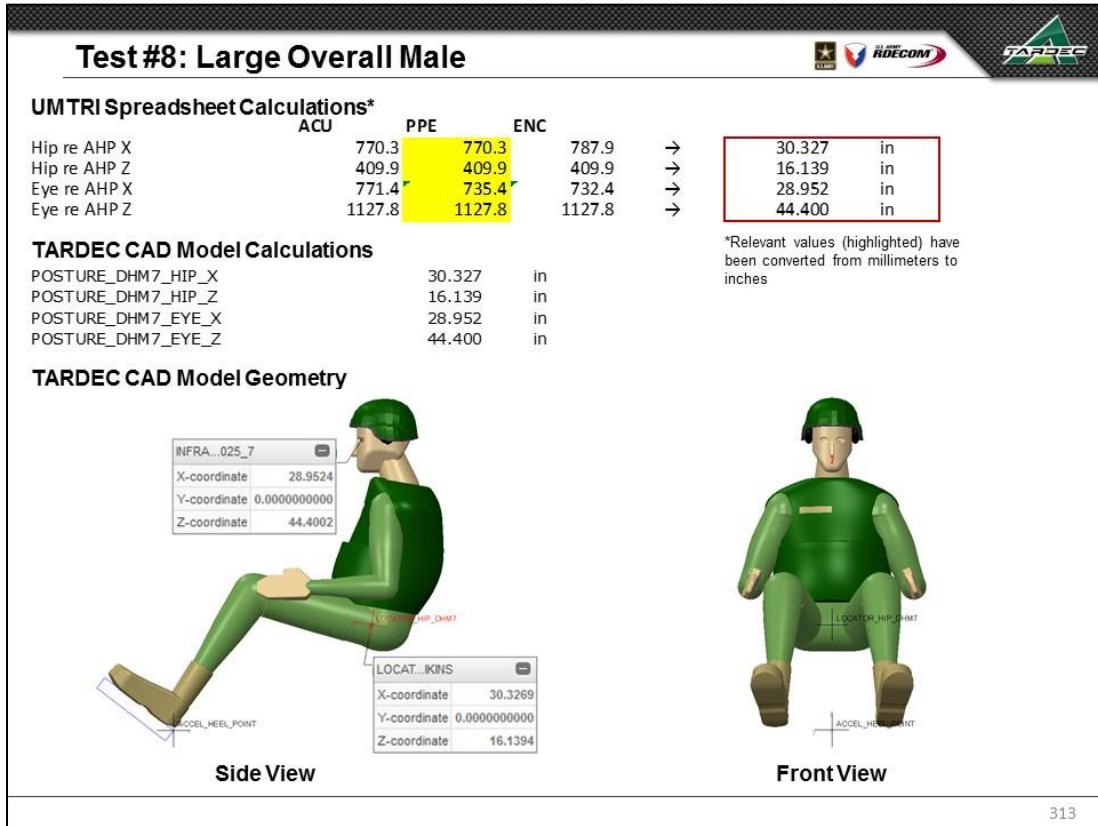

10.7.9 TEST #9 – VARY GENDER MIX AND ENSEMBLE

Test #9: Vary Gender Mix and Ensemble



Target Accommodation	Fraction Male	Ensemble	Steering Wheel Point (SWP) (measured wrt AHP)		Hydration Pack Relief Availability	HARP Measurement Tool
			X (in.) (L11, fore-aft)	Z (in.) (H17, vertical)		
90%	50%	ACU	13.3	29.0	No	SAE J826

Basic Accommodation

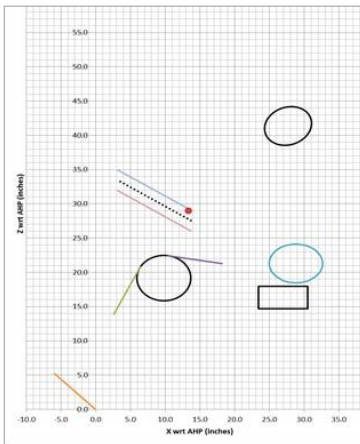

UMTRI Spreadsheet



TARDEC CAD Model

314

Surrogate Steering Wheel			
	UMTRI Value	TARDEC Value	Difference
STEERING_WHEEL_X	13.300 in	13.300 in	0.000 in
STEERING_WHEEL_Z	29.000 in	29.000 in	0.000 in
Steering Wheel Preference Line			
	UMTRI Value	TARDEC Value	Difference
STRG_WHL_FWD_X	13.716 in	13.716 in	0.000 in
STRG_WHL_FWD_Z	27.539 in	27.539 in	0.000 in
STRG_WHL_RWD_X	3.151 in	3.151 in	0.000 in
STRG_WHL_RWD_Z	33.465 in	33.465 in	0.000 in
Steering Wheel Preference Zone			
	UMTRI Value	TARDEC Value	Difference
STRG_WHL_ZONE_Z	1.516 in	1.516 in	0.001 in
STRG_WHL_ZONE_Y	N/A	1.000 in	N/A
Accelerator Plane Angle (APA)			
	UMTRI Value	TARDEC Value	Difference
ACCEL_PEDAL_PLANE_ANG	41.438 deg	41.438 deg	0.000 deg
Origin (X)	0.000 in	0.000 in	0.000 in
Origin (Z)	0.000 in	0.000 in	0.000 in
BOFRP (X)	-5.903 in	-5.903 in	0.000 in
BOFRP (Z)	5.211 in	5.211 in	0.000 in
Seat Track Travel Range			
	UMTRI Value	TARDEC Value	Difference
SEAT_POSITION_CTR_OF_TRAVEL_X	26.947 in	26.947 in	0.000 in
SEAT_POSITION_CTR_OF_TRAVEL_Z	16.319 in	16.319 in	0.000 in
SEAT_POSITION_FORE_AFT_TRAVEL	7.044 in	7.044 in	0.000 in
SEAT_POSITION_VERTICAL_TRAVEL	3.234 in	3.235 in	0.001 in
Seat Back Angle			
	UMTRI Value	TARDEC Value	Difference
SEAT_BACK_ANGLE_LOWER_QUANTILE	16.510 deg	16.507 deg	0.004 deg
SEAT_BACK_ANGLE_UPPER_QUANTILE	26.708 deg	26.712 deg	0.004 deg
Eyellipse			
	UMTRI Value	TARDEC Value	Difference
EYELLIPSE_CENTROID_X	27.668 in	27.668 in	0.000 in
EYELLIPSE_CENTROID_Y (+/-)	1.280 in	1.280 in	0.000 in
EYELLIPSE_CENTROID_Z	41.365 in	41.365 in	0.000 in
EYELLIPSE_ANGLE_REL_X	18.600 deg	18.600 deg	0.000 deg
EYELLIPSE_X_AXIS_LENGTH	6.889 in	6.890 in	0.001 in
EYELLIPSE_Y_AXIS_LENGTH	1.917 in	1.918 in	0.001 in
EYELLIPSE_Z_AXIS_LENGTH	5.484 in	5.486 in	0.002 in

Helmet Boundary			
The ACU ensemble does not include a helmet			

Knee Boundary			
	UMTRI Value	TARDEC Value	Difference
KNEE_CONTOUR_WEIGHTED_CENT_X	9.796 in	9.796 in	0.000 in
KNEE_CONTOUR_WEIGHTED_CENT_Y (+/-)	6.817 in	6.817 in	0.000 in
KNEE_CONTOUR_WEIGHTED_CENT_Z	19.163 in	19.163 in	0.000 in
KNEE_CONTOUR_X_AXIS_LENGTH	7.753 in	7.754 in	0.001 in
KNEE_CONTOUR_Y_AXIS_LENGTH	8.895 in	8.896 in	0.000 in
KNEE_CONTOUR_Z_AXIS_LENGTH	6.615 in	6.615 in	0.000 in
KNEE_SHIN_ANGLE	29.013 deg	29.013 deg	0.000 deg
KNEE_THIGH_ANGLE	8.489 deg	8.489 deg	0.000 deg

Torso Boundary			
A torso boundary is not provided when the ACU ensemble is chosen			

Elbow Boundary			
	UMTRI Value	TARDEC Value	Difference
ELBOW_WEIGHTED_CENT_X	28.796 in	28.796 in	0.000 in
ELBOW_WEIGHTED_CENT_Y (+/-)	11.048 in	11.048 in	0.000 in
ELBOW_WEIGHTED_CENT_Z	21.296 in	21.296 in	0.000 in
ELBOW_X_AXIS_LENGTH	7.683 in	7.681 in	0.000 in
ELBOW_Y_AXIS_LENGTH	3.599 in	3.599 in	0.000 in
ELBOW_Z_AXIS_LENGTH	5.652 in	5.655 in	0.003 in

TARDEC CAD values to agree with UMTRI spreadsheet values within
 ±0.100 inches
 ±0.100 degrees

Largest Observed Differences:
 0.003 inches
 0.004 degrees

Values in agreement

315

Test #9: Surrogate Steering Wheel		
UMTRI Spreadsheet Calculations		
	L11	H17
	(in)	(in)
Steering Wheel Point (SWP)	13.300	29.000
TARDEC CAD Model Calculations		
STEERING_WHEEL_X	13.300	in
STEERING_WHEEL_Z	29.000	in
TARDEC CAD Model Geometry		

316

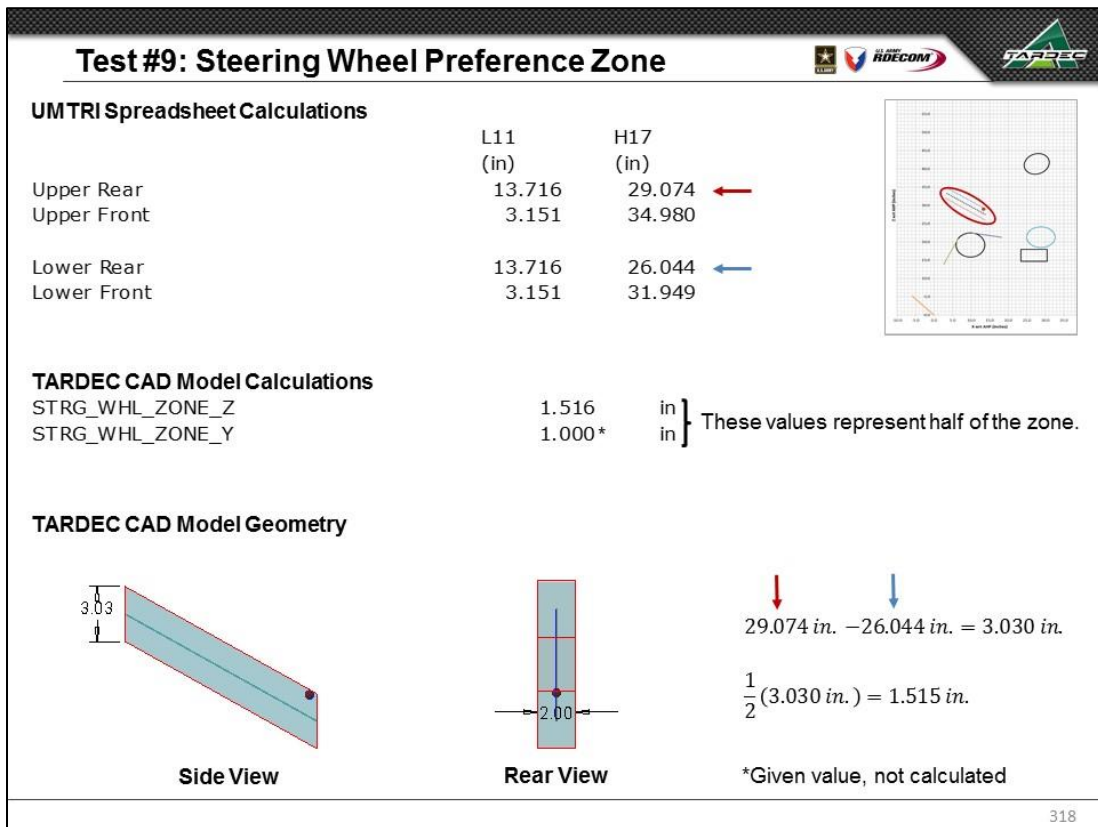
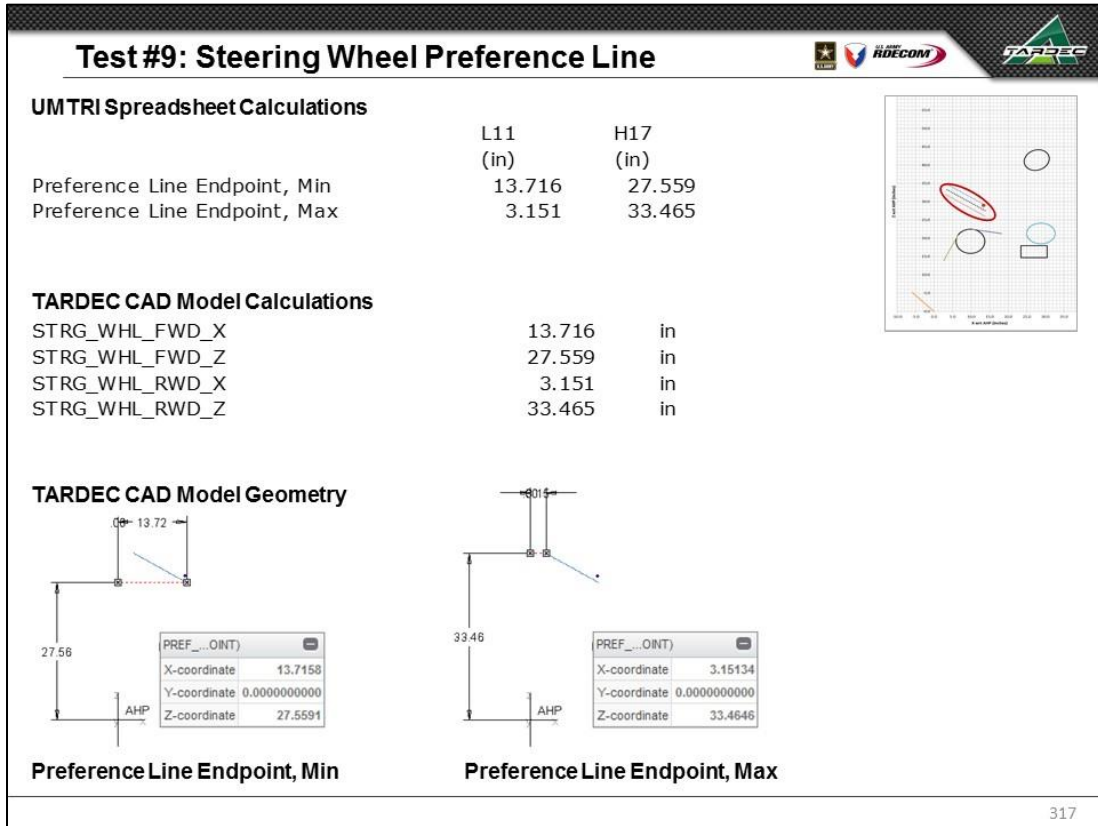

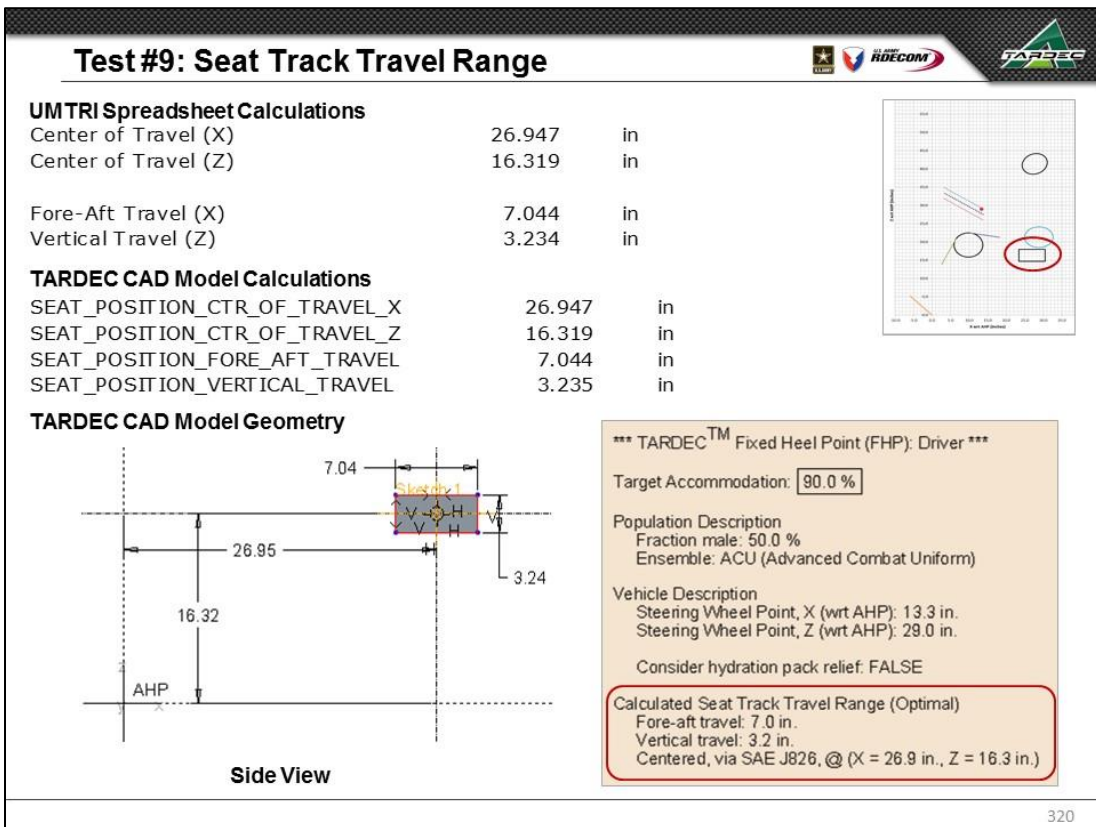
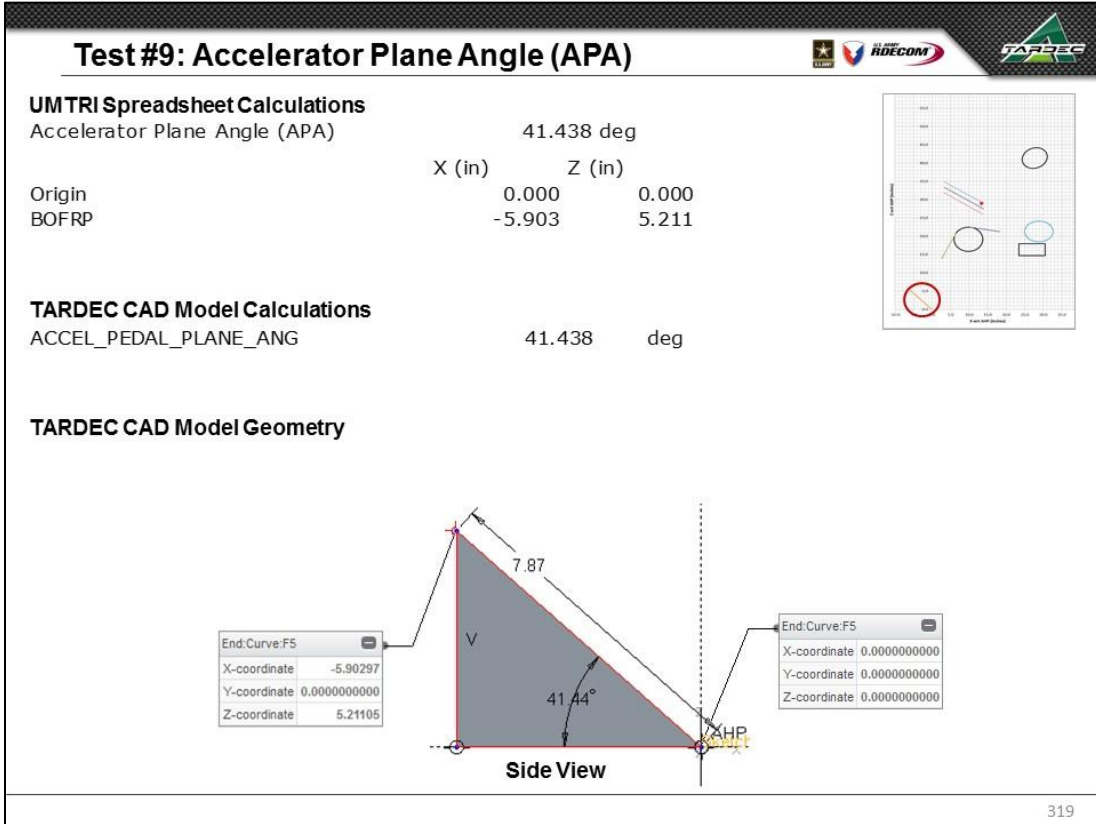

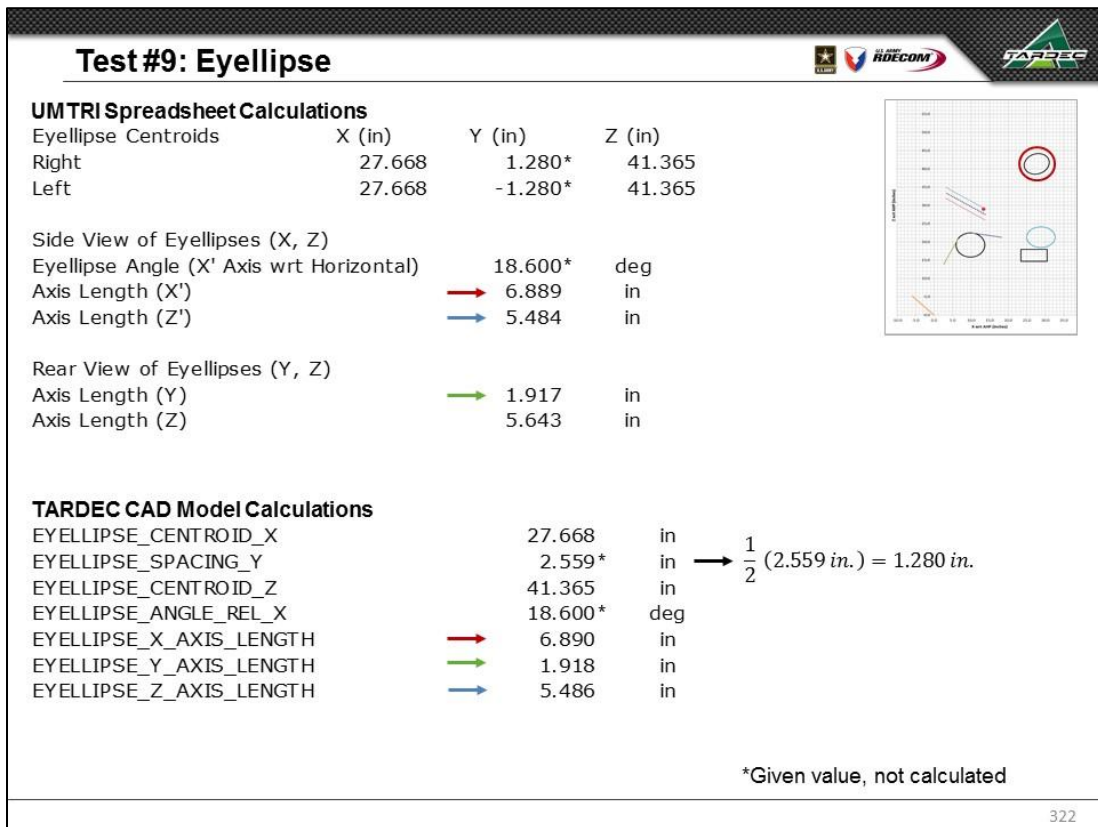
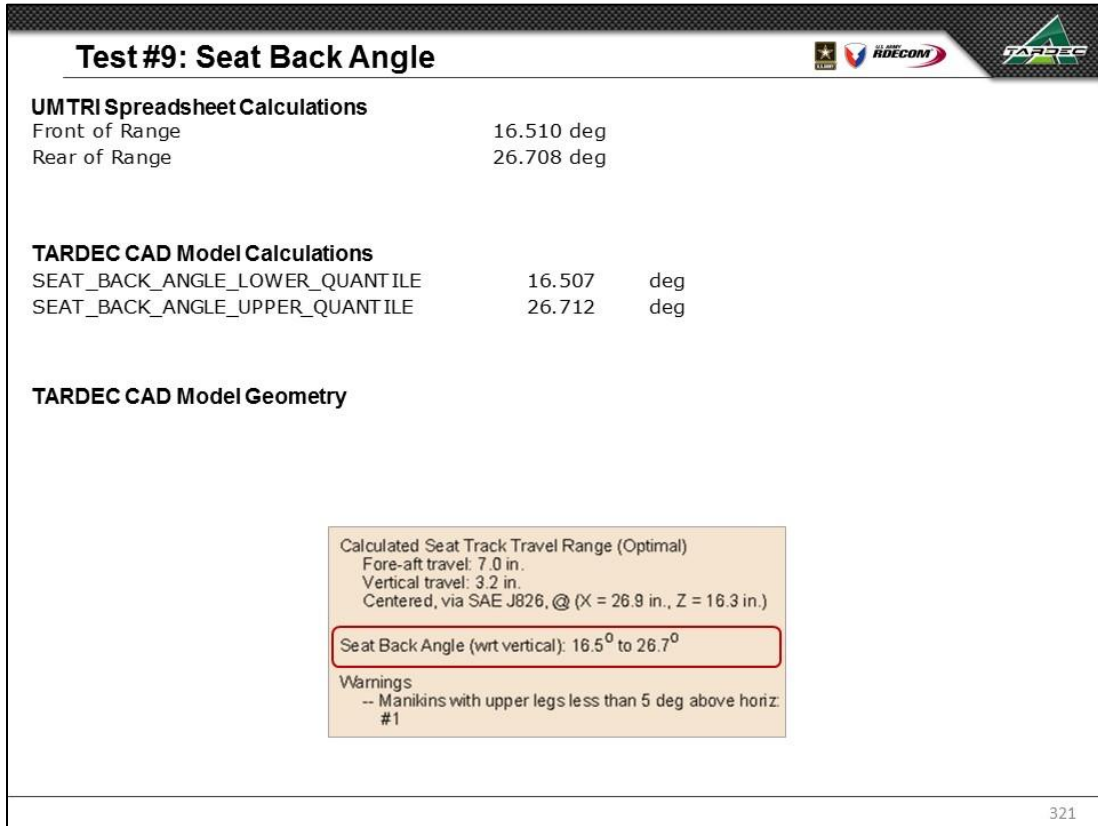

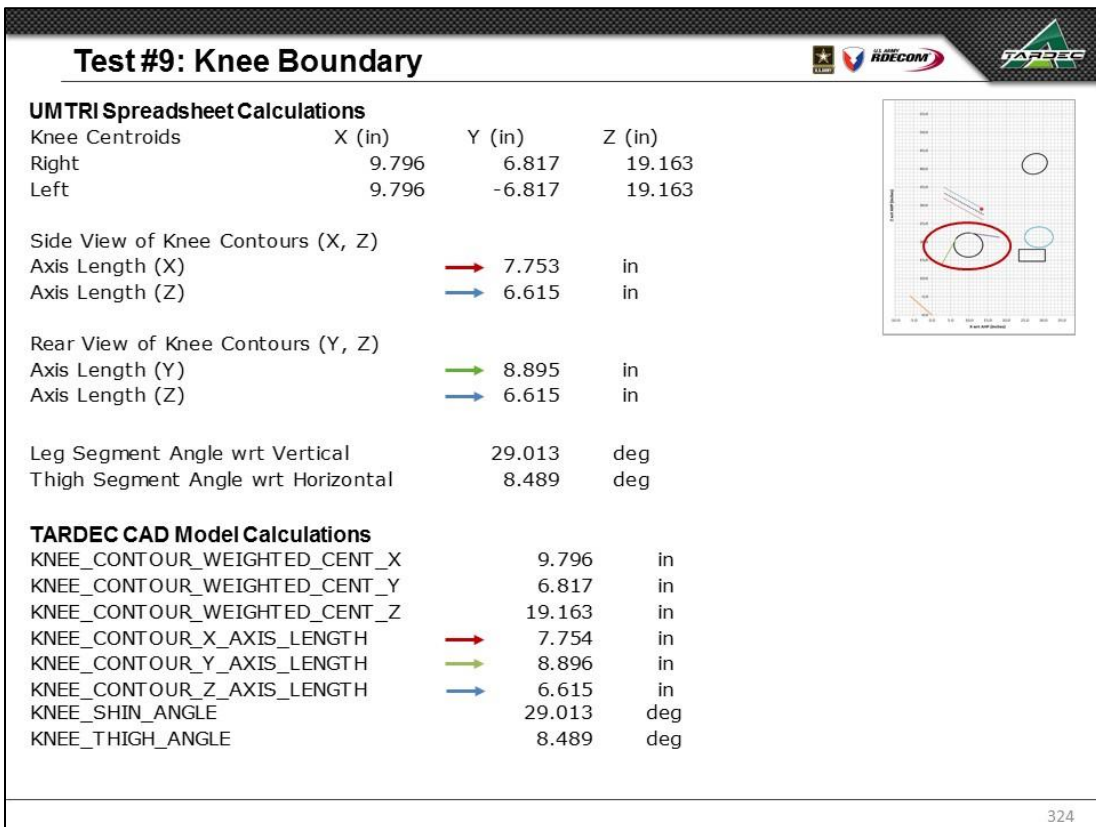
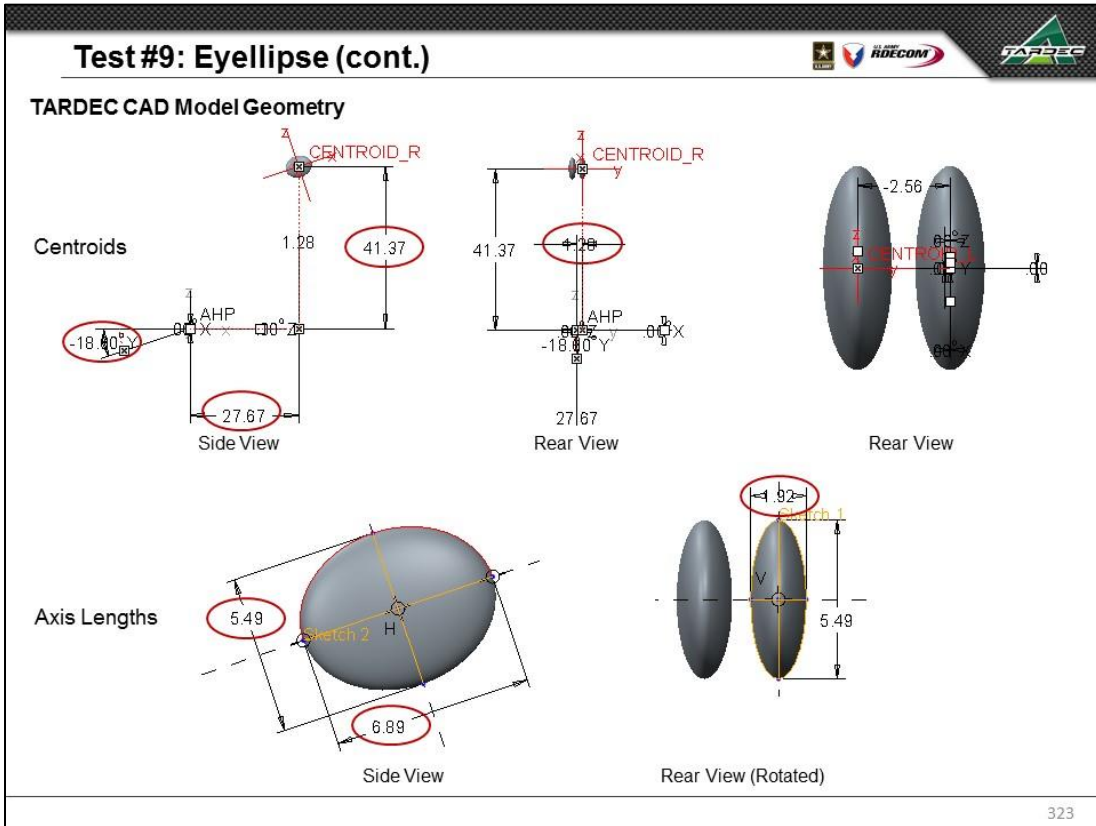

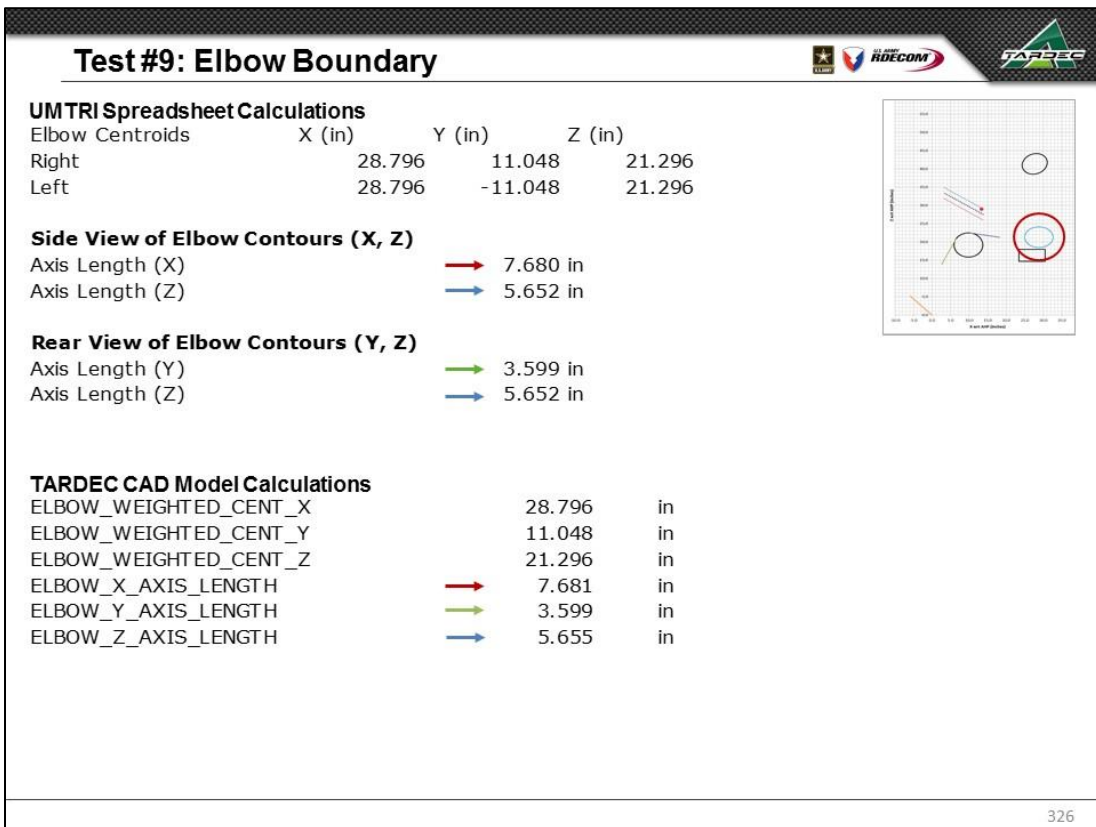
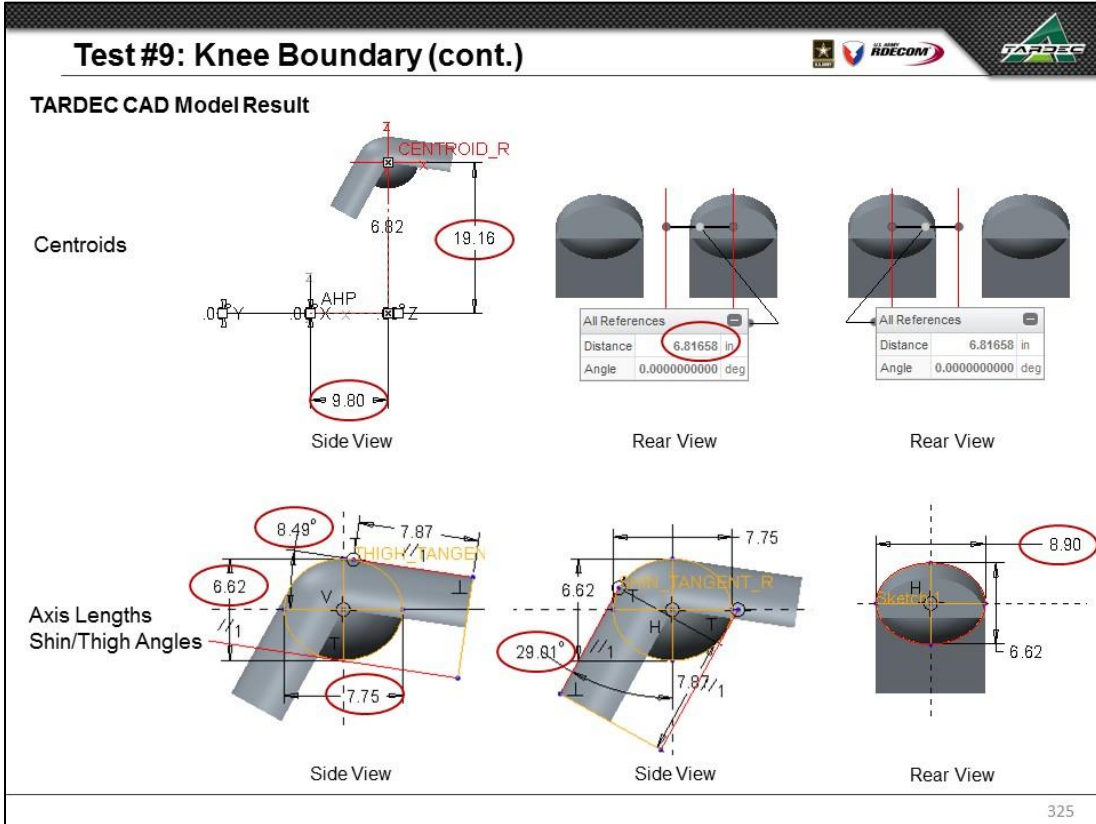

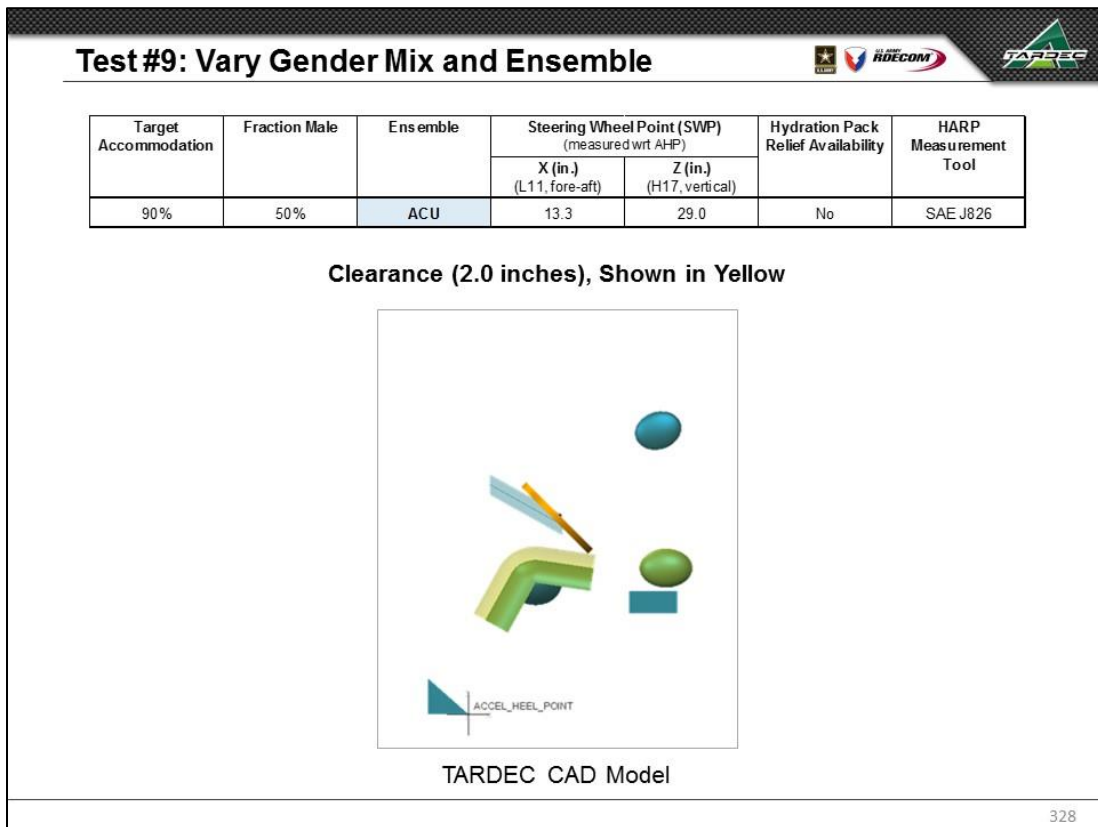
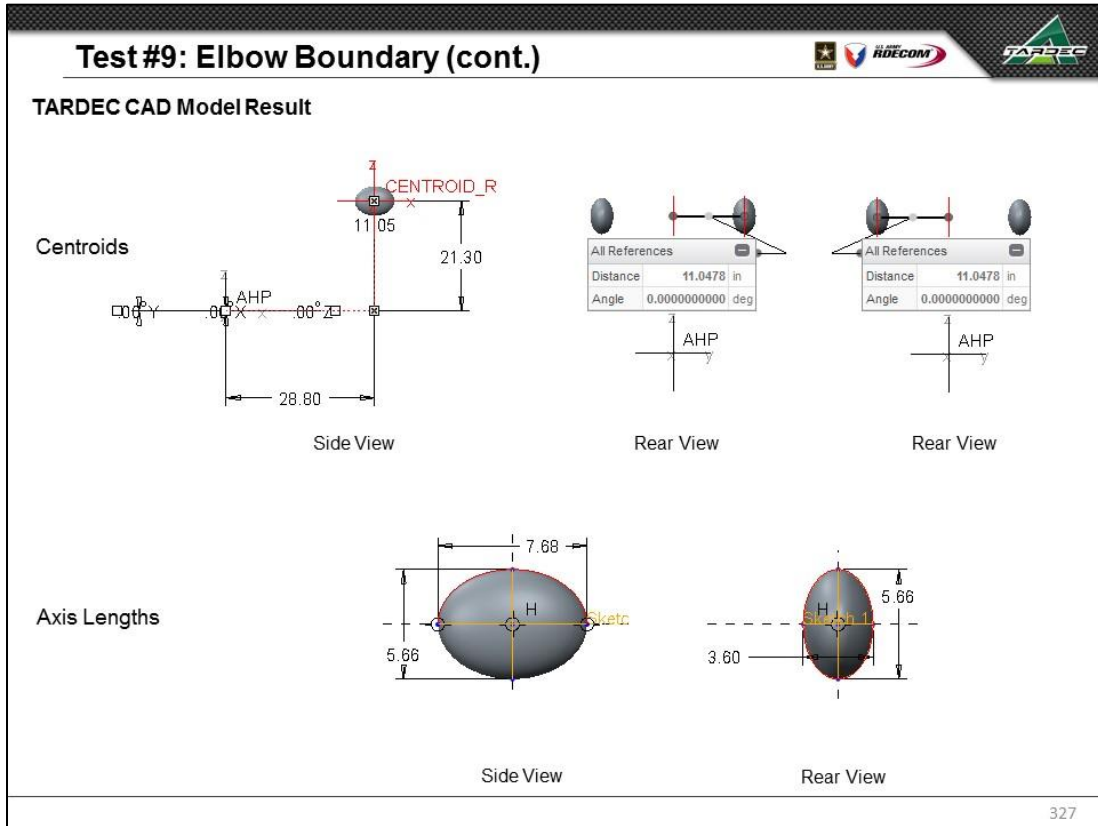

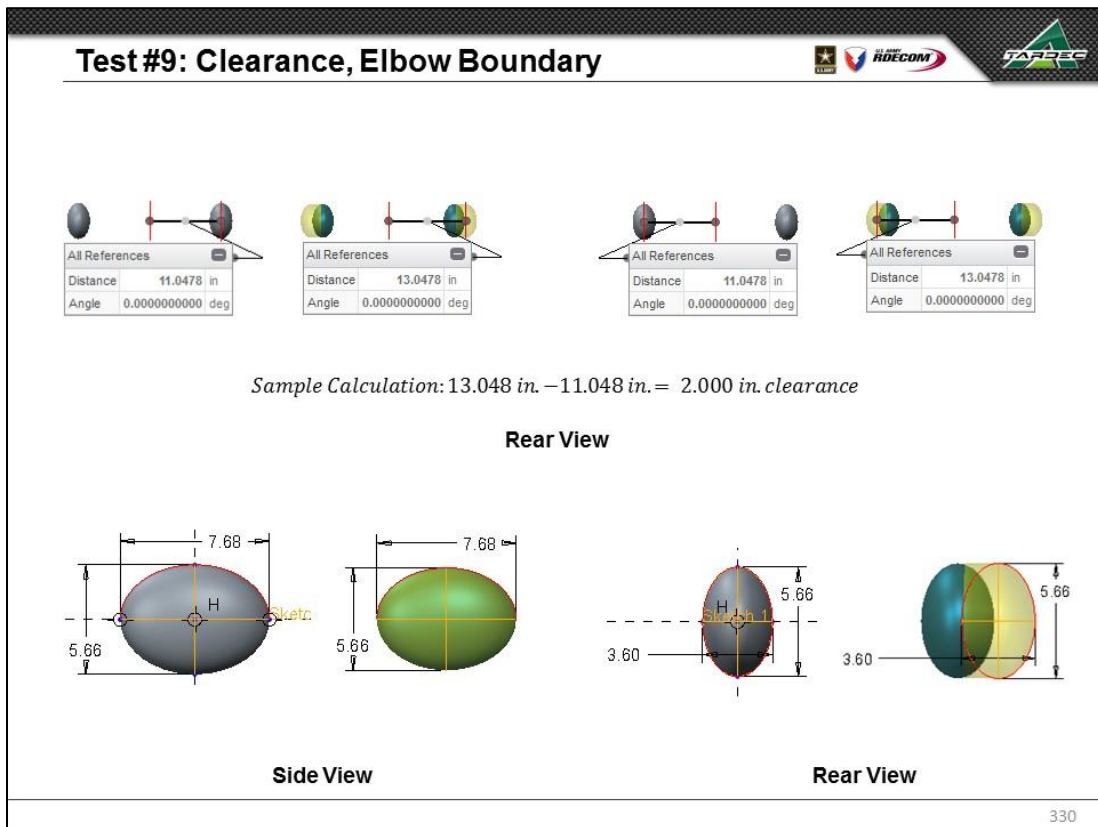
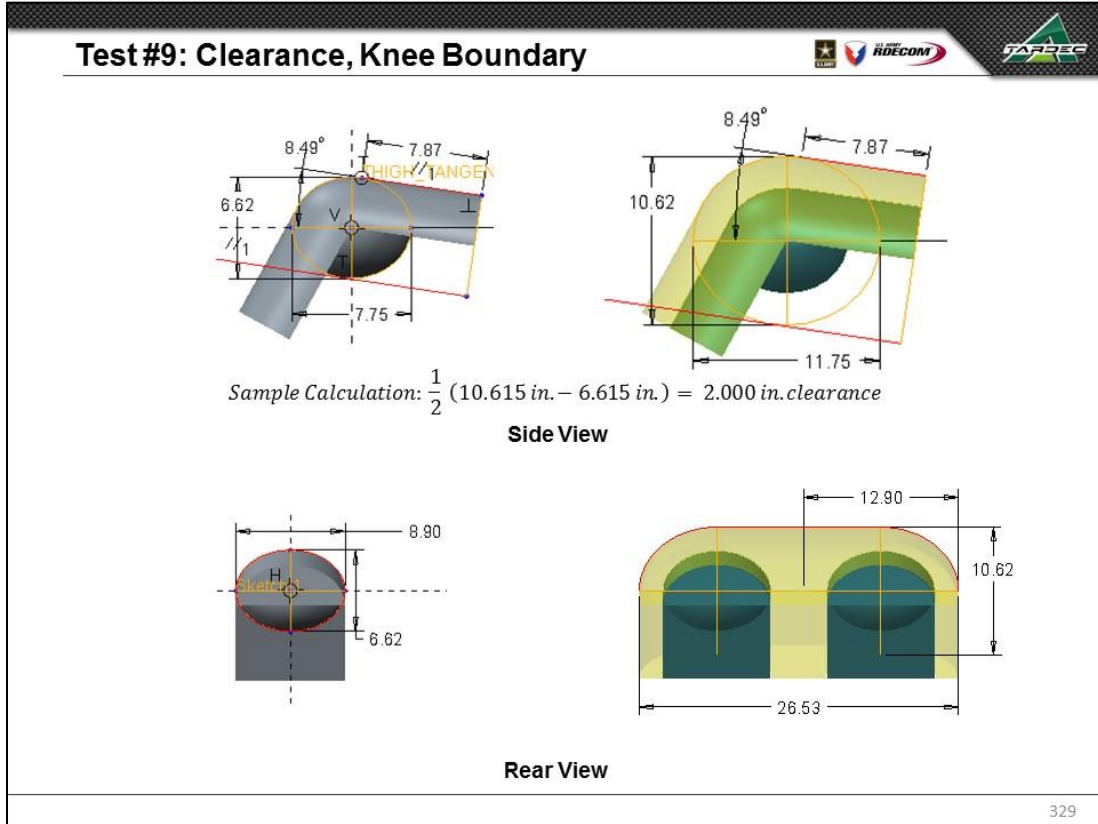

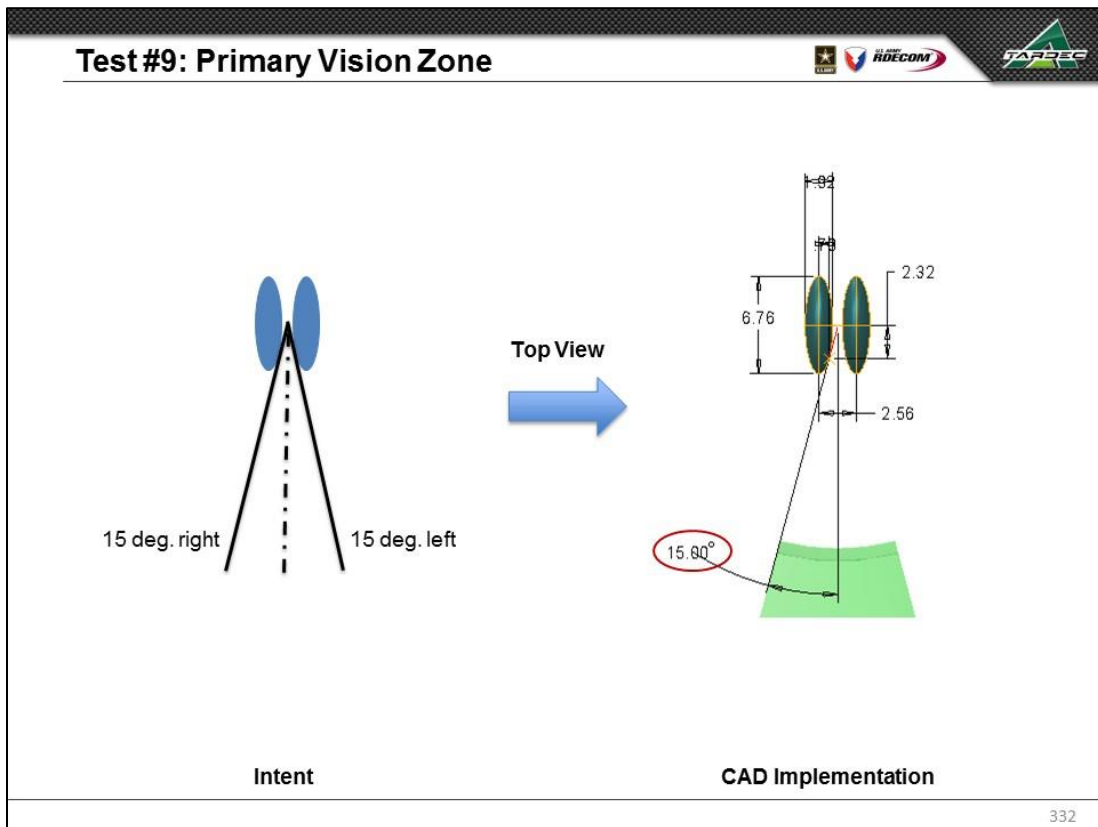
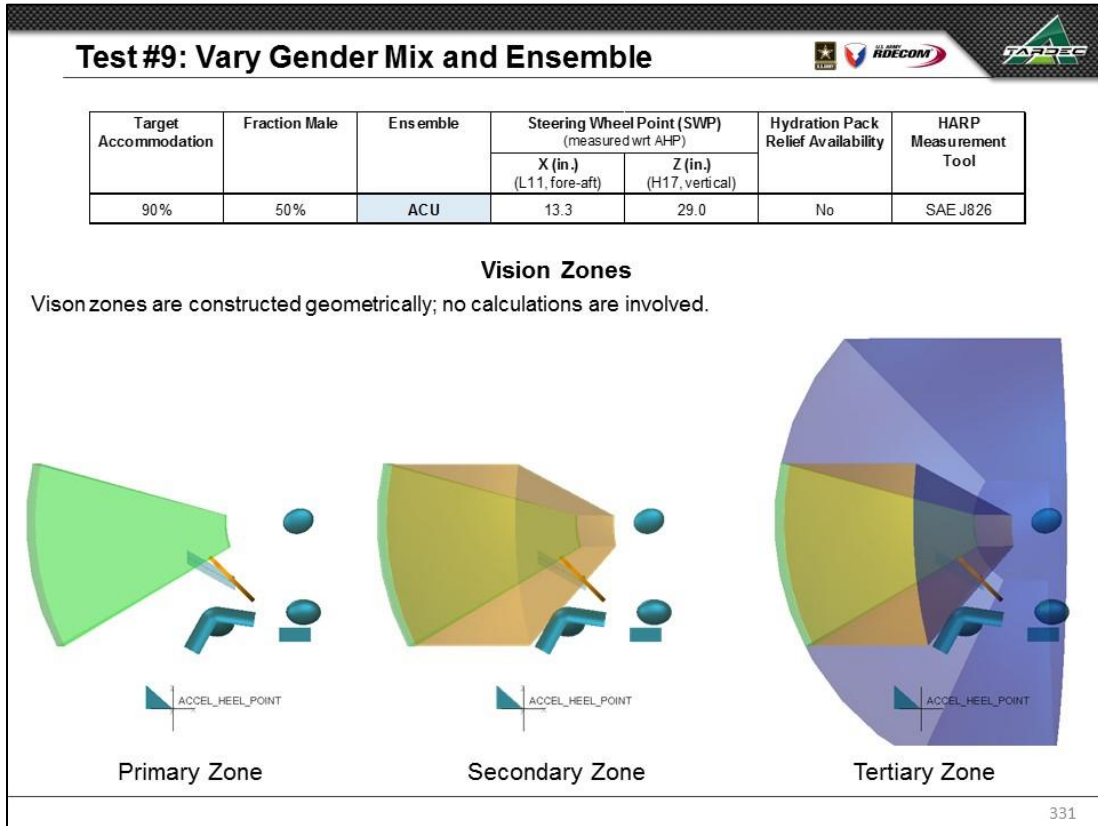

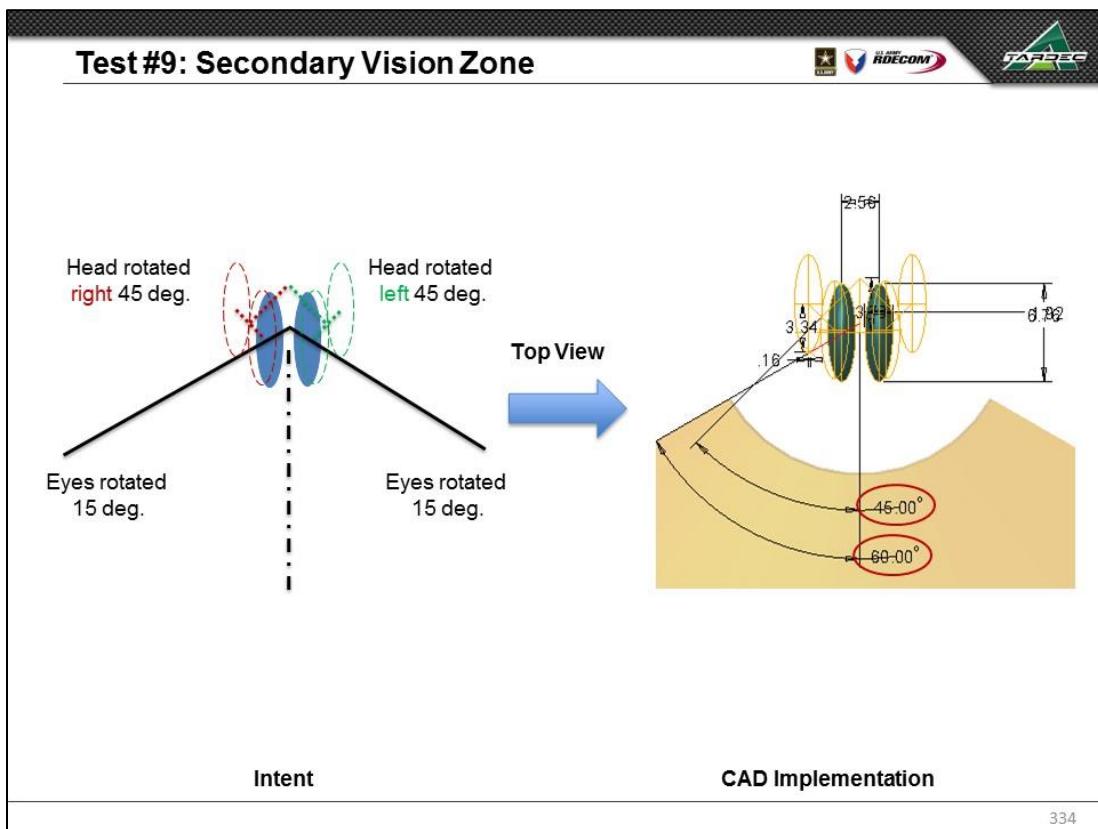
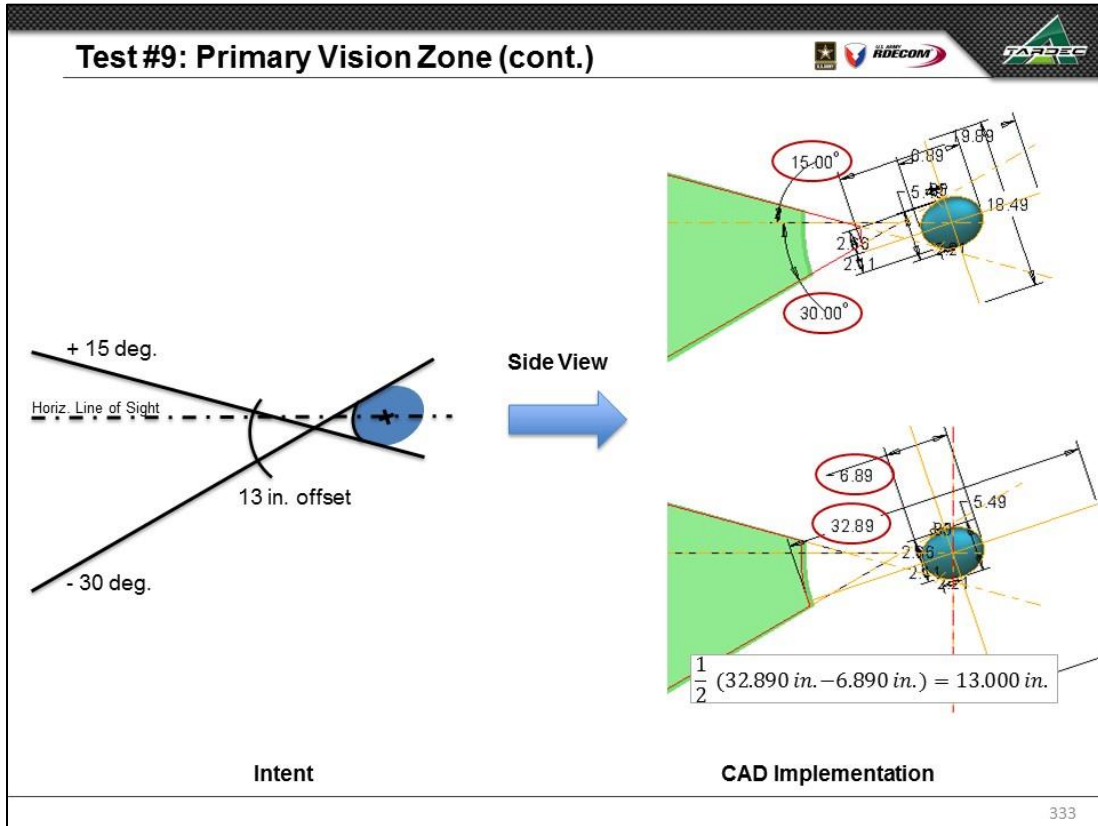

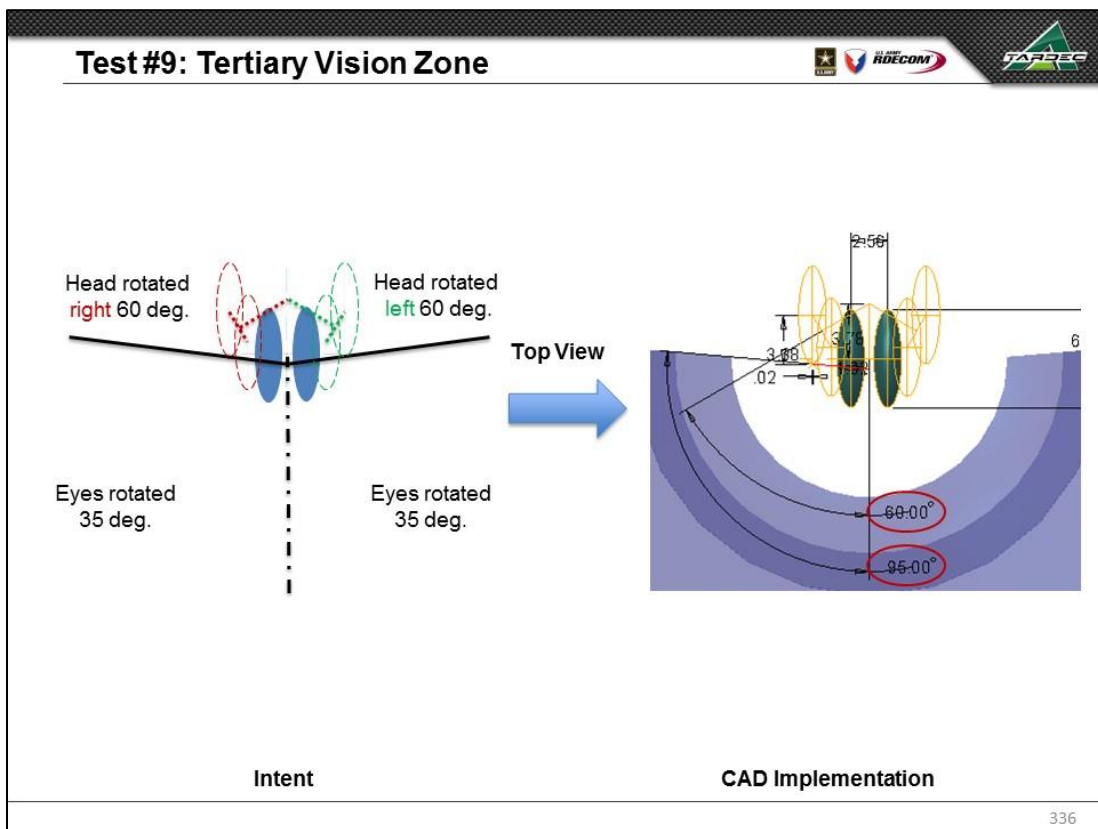
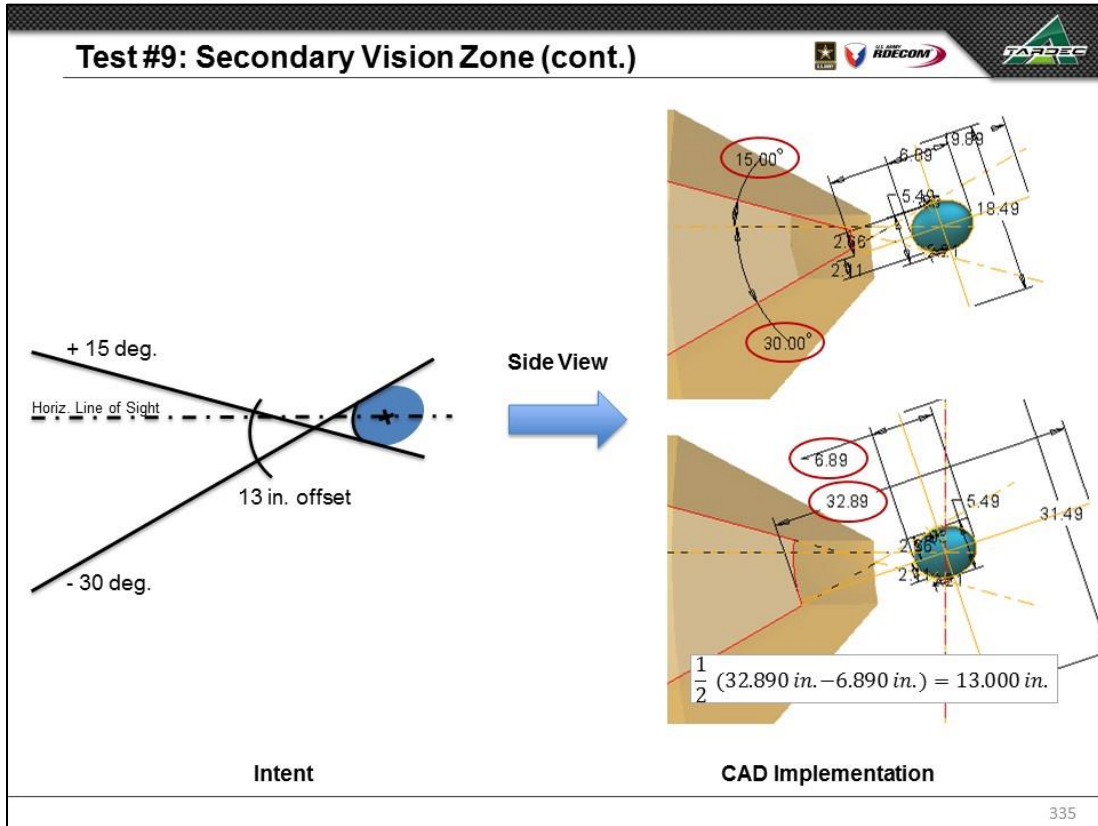

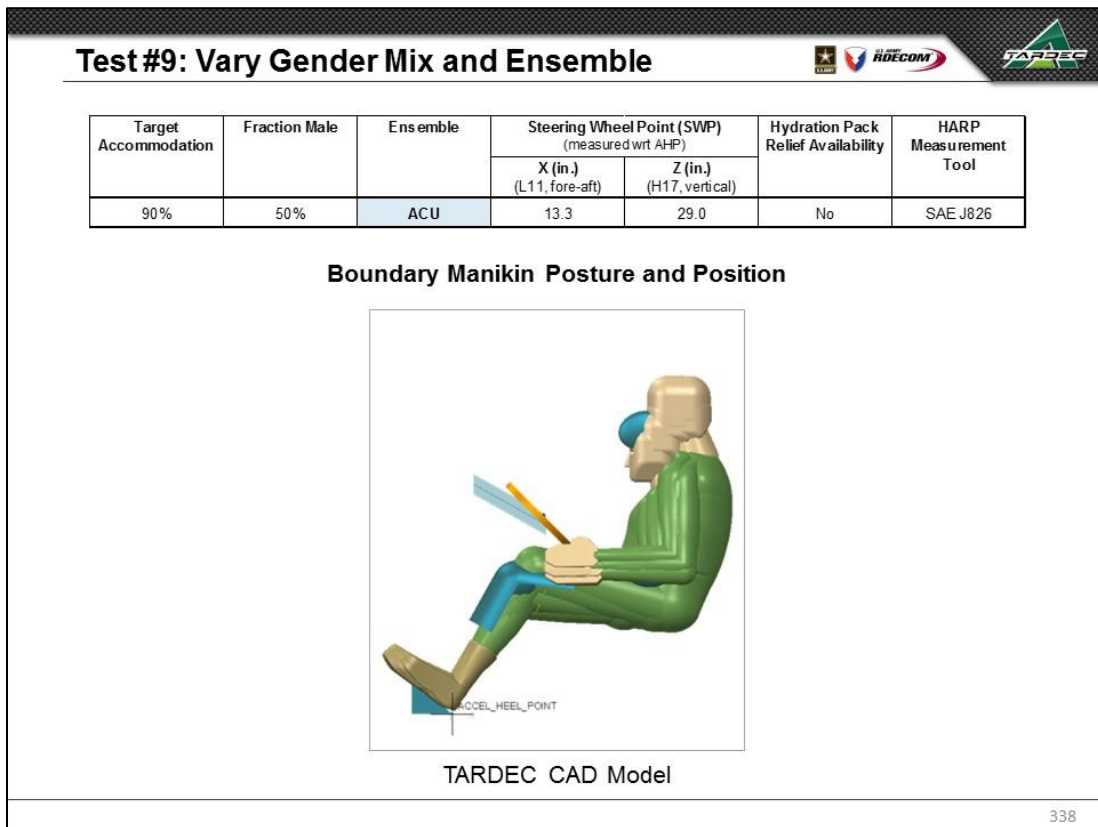
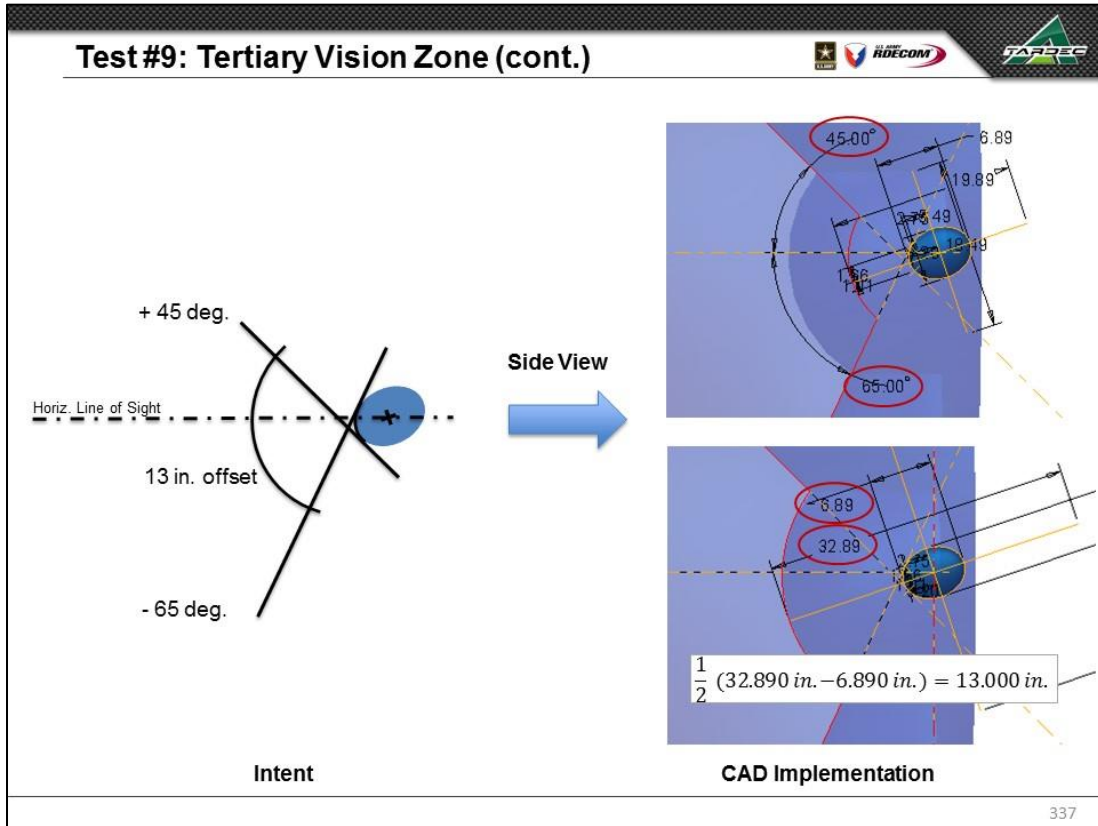

Test #9: Numerical Results, Manikin Positioning

Small Overall Female			
	UMTRI Value	TARDEC Value	Difference
POSTURE_DHM1_HIP_X	23.660 in	23.660 in	0.000 in
POSTURE_DHM1_HIP_Z	15.879 in	15.879 in	0.000 in
POSTURE_DHM1_EYE_X	26.357 in	26.357 in	0.000 in
POSTURE_DHM1_EYE_Z	38.171 in	38.171 in	0.000 in
Small Overall Male			
	UMTRI Value	TARDEC Value	Difference
POSTURE_DHM2_HIP_X	25.782 in	25.782 in	0.000 in
POSTURE_DHM2_HIP_Z	15.989 in	15.989 in	0.000 in
POSTURE_DHM2_EYE_X	27.608 in	27.608 in	0.000 in
POSTURE_DHM2_EYE_Z	39.938 in	39.938 in	0.000 in
Average Size Male			
	UMTRI Value	TARDEC Value	Difference
POSTURE_DHM3_HIP_X	27.977 in	27.977 in	0.000 in
POSTURE_DHM3_HIP_Z	15.988 in	15.988 in	0.000 in
POSTURE_DHM3_EYE_X	29.017 in	29.017 in	0.000 in
POSTURE_DHM3_EYE_Z	42.162 in	42.162 in	0.000 in
Widest Shoulders Male			
	UMTRI Value	TARDEC Value	Difference
POSTURE_DHM4_HIP_X	28.985 in	28.985 in	0.000 in
POSTURE_DHM4_HIP_Z	15.977 in	15.977 in	0.000 in
POSTURE_DHM4_EYE_X	29.673 in	29.673 in	0.000 in
POSTURE_DHM4_EYE_Z	43.440 in	43.440 in	0.000 in
Longest Torso Male			
	UMTRI Value	TARDEC Value	Difference
POSTURE_DHM5_HIP_X	28.229 in	28.229 in	0.000 in
POSTURE_DHM5_HIP_Z	15.971 in	15.971 in	0.000 in
POSTURE_DHM5_EYE_X	29.183 in	29.183 in	0.000 in
POSTURE_DHM5_EYE_Z	44.441 in	44.441 in	0.000 in
Longest Legs Male			
	UMTRI Value	TARDEC Value	Difference
POSTURE_DHM6_HIP_X	30.501 in	30.502 in	0.000 in
POSTURE_DHM6_HIP_Z	16.042 in	16.042 in	0.000 in
POSTURE_DHM6_EYE_X	30.593 in	30.593 in	0.000 in
POSTURE_DHM6_EYE_Z	42.661 in	42.661 in	0.000 in
Large Overall Male			
	UMTRI Value	TARDEC Value	Difference
POSTURE_DHM7_HIP_X	30.327 in	30.327 in	0.000 in
POSTURE_DHM7_HIP_Z	16.139 in	16.139 in	0.000 in
POSTURE_DHM7_EYE_X	30.370 in	30.370 in	0.000 in
POSTURE_DHM7_EYE_Z	44.400 in	44.400 in	0.000 in

TARDEC CAD values to agree with UMTRI spreadsheet values within
 ±0.100 inches
 ±0.100 degrees

Largest Observed Differences:
 0.000 inches

Values in agreement

339

Test #9: Small Overall Female



UMTRI Spreadsheet Calculations*

	ACU	PPE	ENC		
Hip re AHP X	601.0	601.0	618.6	→	23.660 in
Hip re AHP Z	403.3	403.3	403.3	→	15.879 in
Eye re AHP X	669.5	633.5	630.5	→	26.357 in
Eye re AHP Z	969.6	969.6	969.6	→	38.171 in

TARDEC CAD Model Calculations

POSTURE_DHM1_HIP_X	23.660	in
POSTURE_DHM1_HIP_Z	15.879	in
POSTURE_DHM1_EYE_X	26.357	in
POSTURE_DHM1_EYE_Z	38.171	in

TARDEC CAD Model Geometry

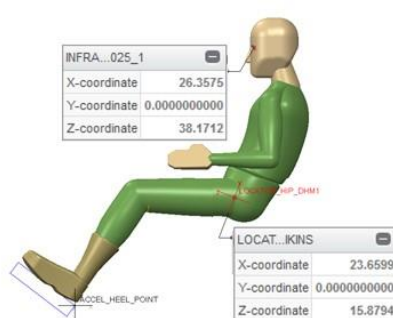

Side View



Front View

*Relevant values (highlighted) have been converted from millimeters to inches

340

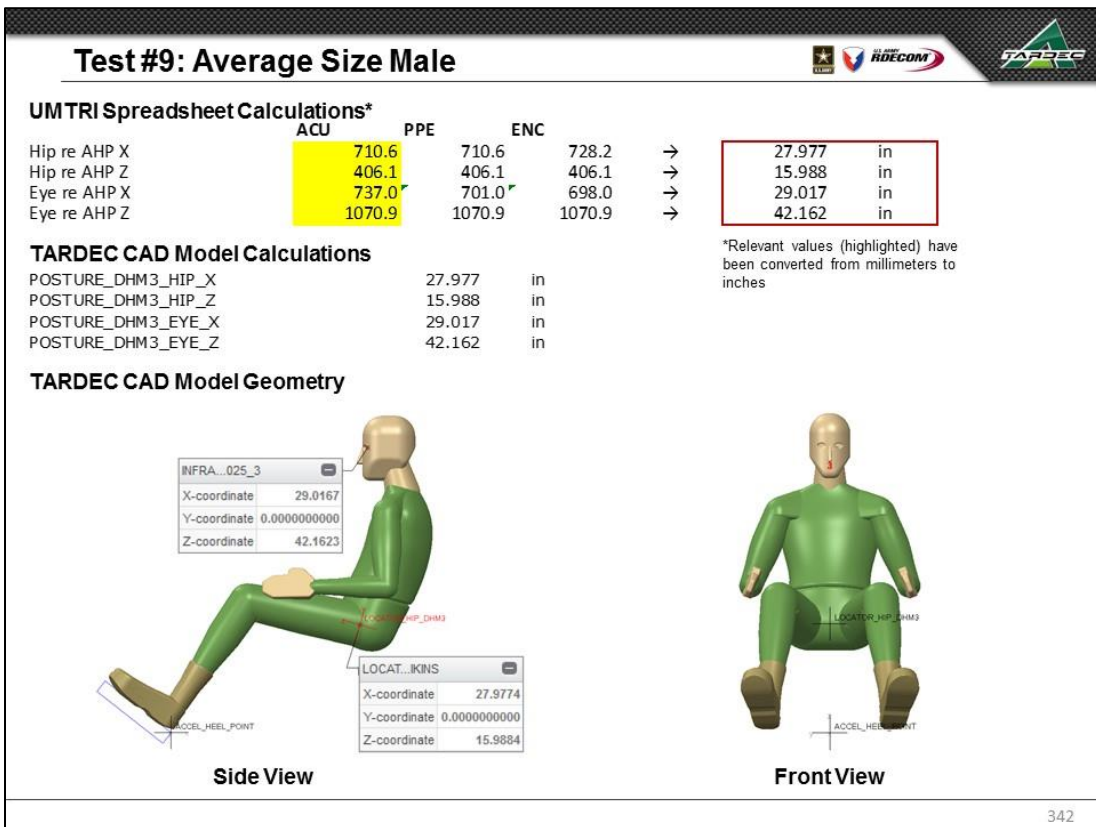
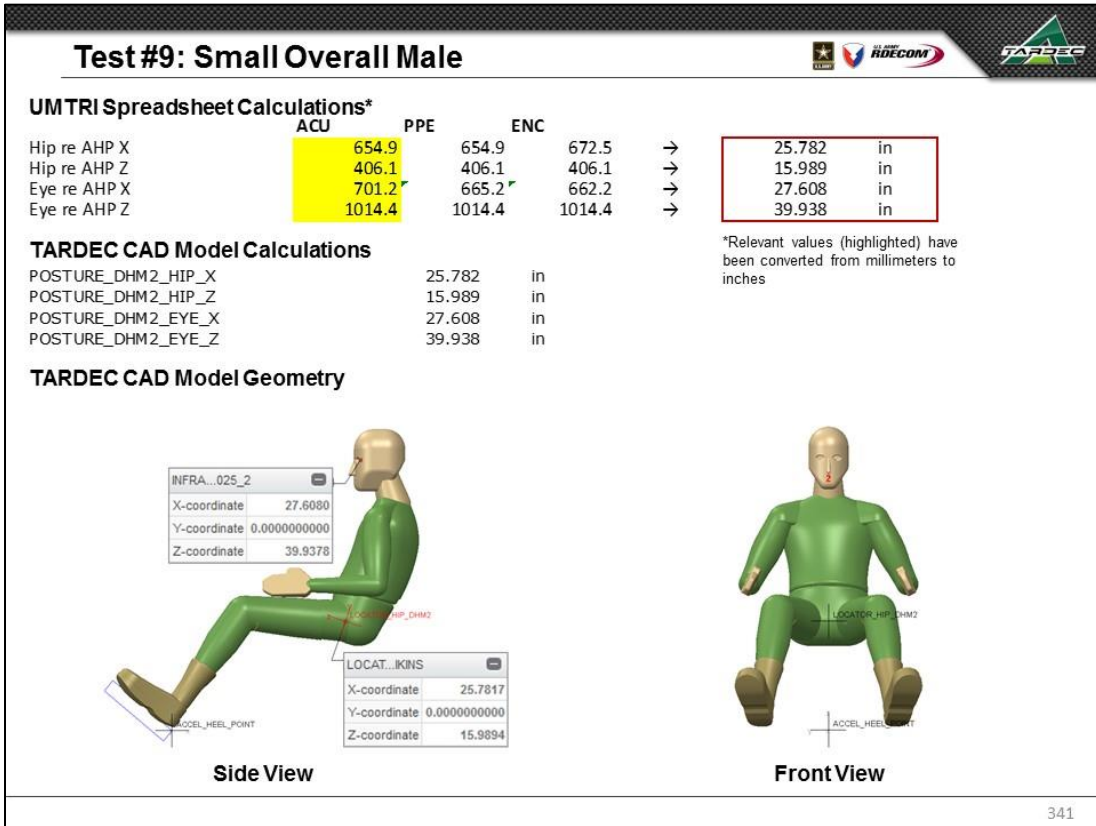

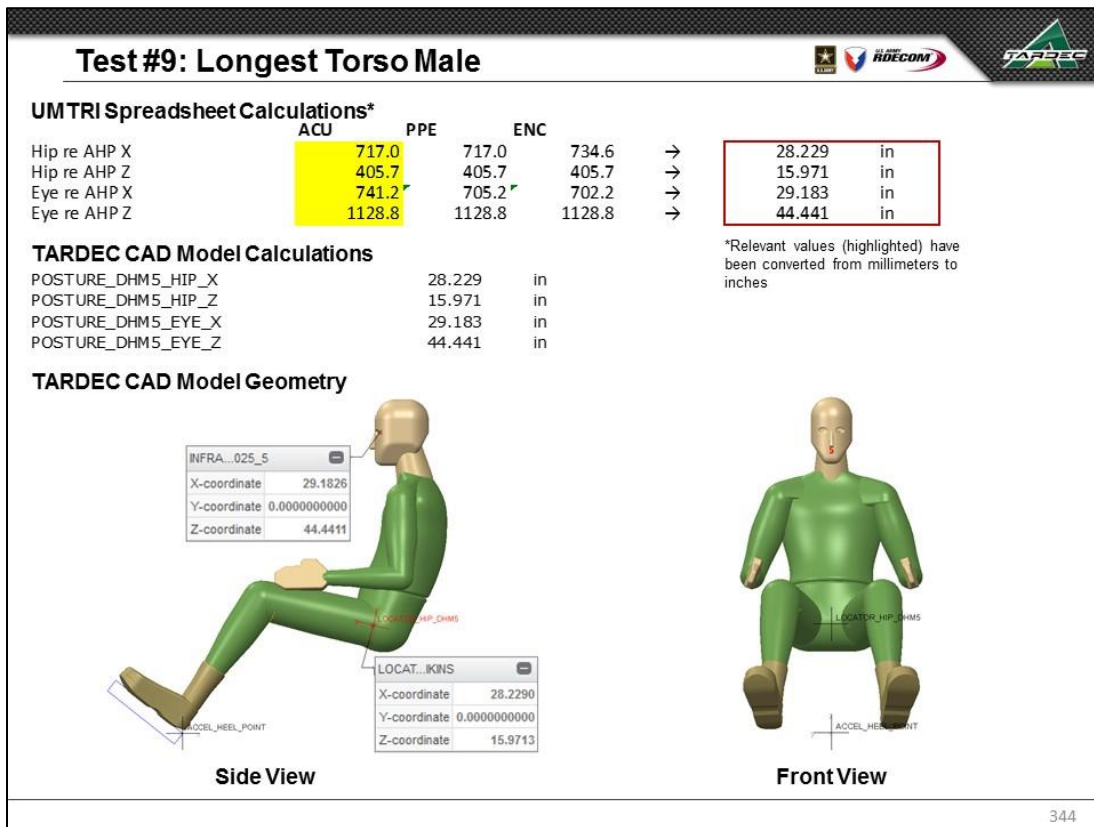
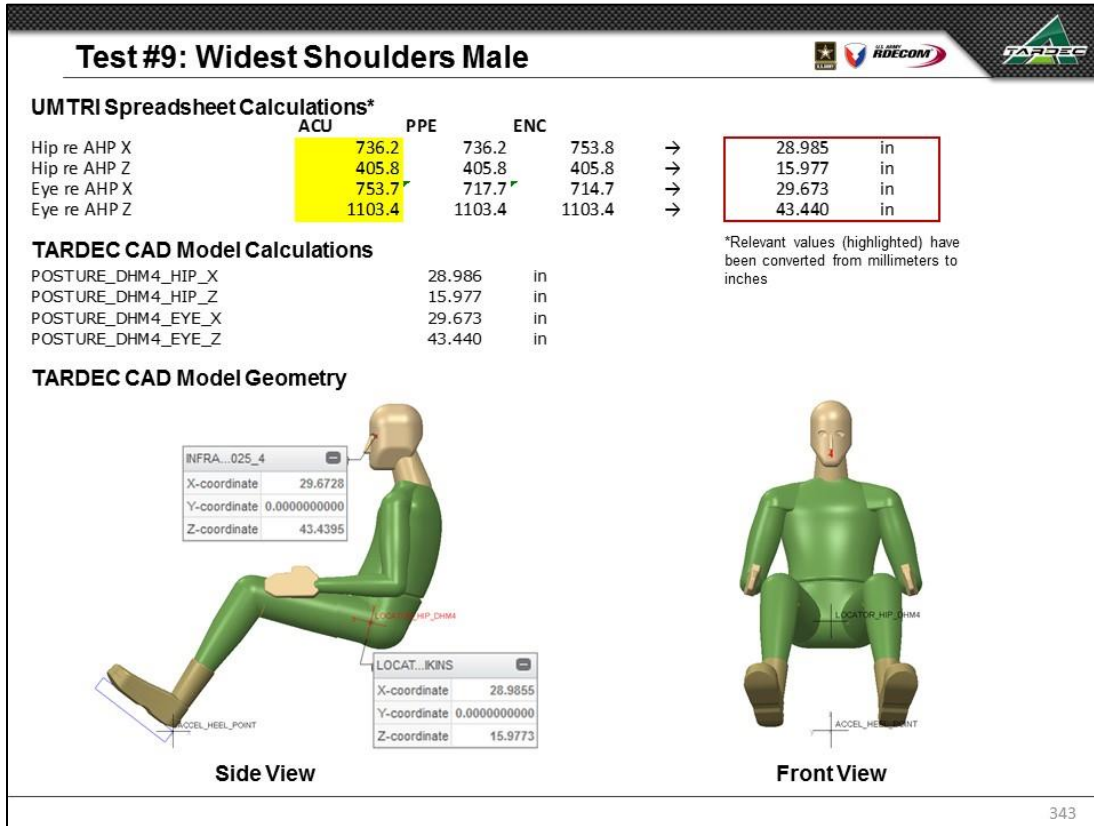

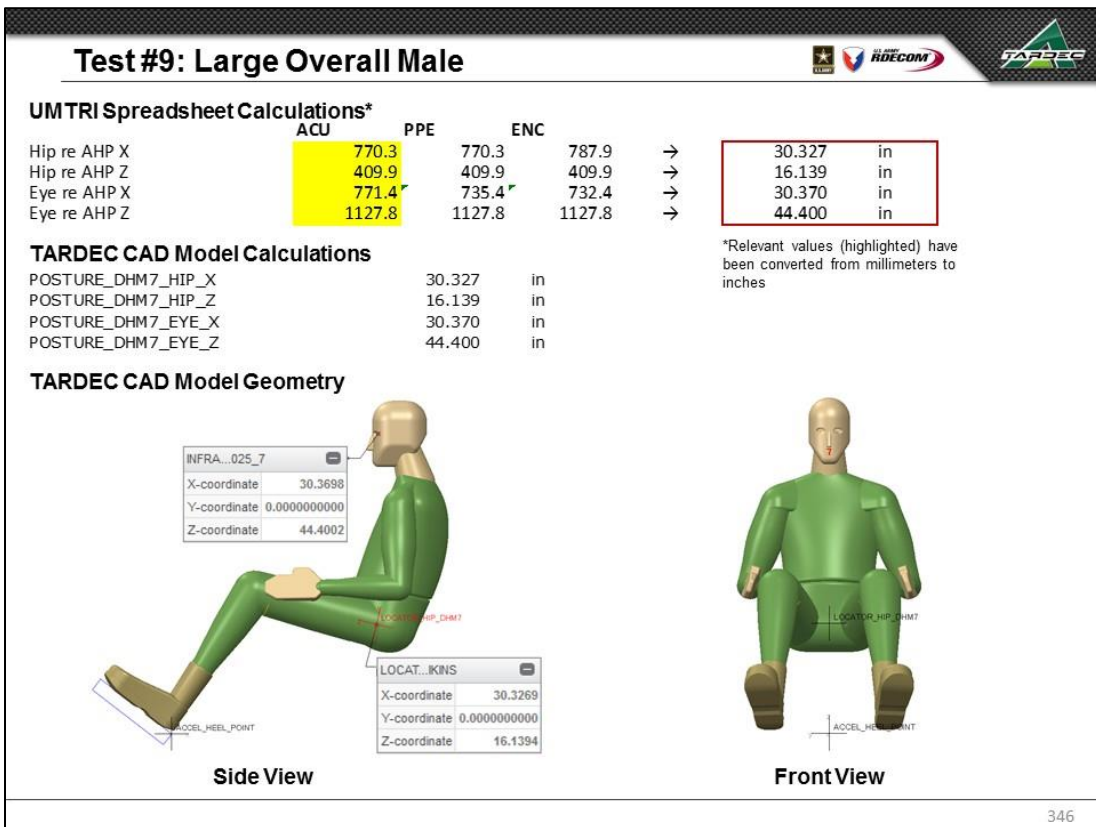
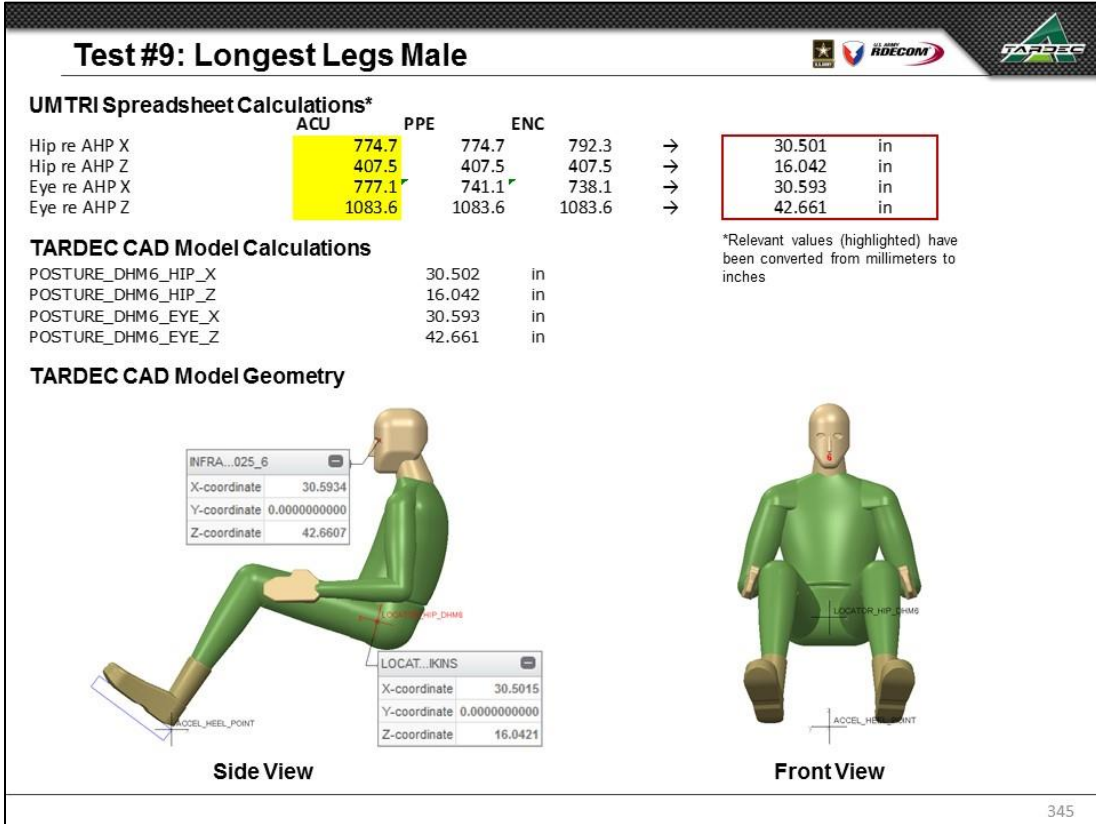

10.7.10 TEST #10 – VARY GENDER MIX, ENSEMBLE, AND PROVIDE HYDRATION PACK RELIEF

Test #10: Vary Gender Mix, Ensemble, and Provide Hydration Pack Relief



Target Accommodation	Fraction Male	Ensemble	Steering Wheel Point (SWP) (measured wrt AHP)		Hydration Pack Relief Availability	HARP Measurement Tool
			X (in.) (L11, fore-aft)	Z (in.) (H17, vertical)		
90%	50%	ENC	13.3	29.0	Yes	SAE J826

Basic Accommodation

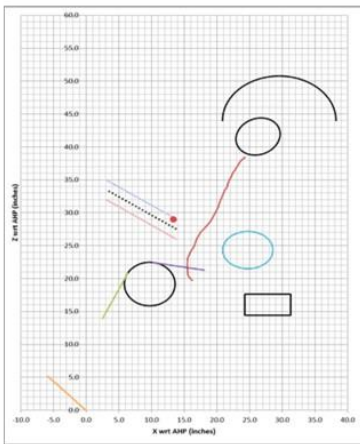

UMTRI Spreadsheet



TARDEC CAD Model

347

Surrogate Steering Wheel				Helmet Boundary			
	UMTRI Value	TARDEC Value	Difference		UMTRI Value	TARDEC Value	Difference
STEERING_WHEEL_X	13.300	13.300	0.000	HELMET_CONTOUR_CBTRD_X	29.515	29.515	0.000
STEERING_WHEEL_Z	29.000	29.000	0.000	HELMET_CONTOUR_CBTRD_Y (+/-)	2.185	2.185	0.000
Steering Wheel Preference Line				Knee Boundary			
	UMTRI Value	TARDEC Value	Difference		UMTRI Value	TARDEC Value	Difference
STRG_WHL_FWD_X	13.716	13.716	0.000	KNEE_CONTOUR_WEIGHTED_CENT_X	9.709	9.709	0.000
STRG_WHL_FWD_Z	27.559	27.559	0.000	KNEE_CONTOUR_WEIGHTED_CENT_Y (+/-)	6.817	6.817	0.000
STRG_WHL_RWD_X	3.151	3.151	0.000	KNEE_CONTOUR_WEIGHTED_CENT_Z	19.163	19.163	0.000
STRG_WHL_RWD_Z	33.465	33.465	0.000	KNEE_CONTOUR_X_AXIS_LENGTH	7.753	7.754	0.001
Steering Wheel Preference Zone				Torso Boundary			
	UMTRI Value	TARDEC Value	Difference		UMTRI Value	TARDEC Value	Difference
STRG_WHL_ZONE_Z	1.518	1.518	0.001	TORSO_WEIGHTED_REF_PT_ENC_Z	15.983	15.983	0.000
STRG_WHL_ZONE_Y	N/A	1.000	N/A	TORSO_WEIGHTED_REF_PT_ENC_X	27.795	27.795	0.000
Accelerator Plane Angle (APA)				Elbow Boundary			
	UMTRI Value	TARDEC Value	Difference		UMTRI Value	TARDEC Value	Difference
ACCEL_PEDAL_PLANE_ANG	41.438	41.438	0.000	ELBOW_WEIGHTED_CBNT_X	24.717	24.717	0.000
Origin (X)	0.000	0.000	0.000	ELBOW_WEIGHTED_CBNT_Y (+/-)	14.276	14.276	0.000
Origin (Z)	0.000	0.000	0.000	ELBOW_WEIGHTED_CBNT_Z	24.331	24.331	0.000
BOFRP (X)	-5.903	-5.903	0.000	ELBOW_X_AXIS_LENGTH	7.683	7.681	0.002
BOFRP (Z)	5.211	5.211	0.000	ELBOW_Y_AXIS_LENGTH	3.599	3.599	0.000
Seat Track Travel Range				Elbow Z Axis Length			
	UMTRI Value	TARDEC Value	Difference		UMTRI Value	TARDEC Value	Difference
SEAT_POSITION_CTR_OF_TRAVEL_X	27.766	27.766	0.000	ELBOW_Z_AXIS_LENGTH	5.652	5.655	0.003
SEAT_POSITION_CTR_OF_TRAVEL_Z	16.023	16.023	0.000	Eyellipse			
SEAT_POSITION_FORE_AFT_TRAVEL	7.044	7.044	0.000				
SEAT_POSITION_VERTICAL_TRAVEL	3.234	3.235	0.001				
Seat Back Angle				Eyellipse			
	UMTRI Value	TARDEC Value	Difference	EYELLIPSE_CBTRD_X	26.271	26.271	0.000
SEAT_BACK_ANGLE_LOWER_QUANTILE	19.110	19.107	0.004	EYELLIPSE_CBTRD_Y (+/-)	1.280	1.280	0.000
SEAT_BACK_ANGLE_UPPER_QUANTILE	29.308	29.312	0.004	EYELLIPSE_CBTRD_Z	41.582	41.582	0.000
Eyellipse				EYELLIPSE_ANGLE_REL_X	18.600	18.600	0.000
	UMTRI Value	TARDEC Value	Difference	EYELLIPSE_X_AXIS_LENGTH	6.889	6.890	0.001
EYELLIPSE_CBTRD_X	26.271	26.271	0.000	EYELLIPSE_Y_AXIS_LENGTH	1.917	1.918	0.001
EYELLIPSE_CBTRD_Y (+/-)	1.280	1.280	0.000	EYELLIPSE_Z_AXIS_LENGTH	5.484	5.486	0.002
EYELLIPSE_CBTRD_Z	41.582	41.582	0.000	Values in agreement			
EYELLIPSE_ANGLE_REL_X	18.600	18.600	0.000				
EYELLIPSE_X_AXIS_LENGTH	6.889	6.890	0.001				
EYELLIPSE_Y_AXIS_LENGTH	1.917	1.918	0.001				
EYELLIPSE_Z_AXIS_LENGTH	5.484	5.486	0.002				

TARDEC CAD values to agree with UMTRI spreadsheet values within
 ±0.100 inches
 ±0.100 degrees
 Largest Observed Differences:
 0.003 inches
 0.004 degrees

Values in agreement

Test #10: Surrogate Steering Wheel

UMTRI Spreadsheet Calculations

	L11 (in)	H17 (in)
Steering Wheel Point (SWP)	13.300	29.000

TARDEC CAD Model Calculations

Parameter	Value	Unit
STEERING_WHEEL_X	13.300	in
STEERING_WHEEL_Z	29.000	in

TARDEC CAD Model Geometry

The diagrams illustrate the geometry of the surrogate steering wheel. The 'Side View' shows the wheel's position relative to the AHP (Accelerator Heel Point) with a horizontal distance of 13.30 inches and a vertical distance of 29.00 inches. The 'Steering Wheel Geometry' shows a circular wheel with a diameter of 13.78 inches, a 45-degree angle, and a 1.00 inch offset from the center.

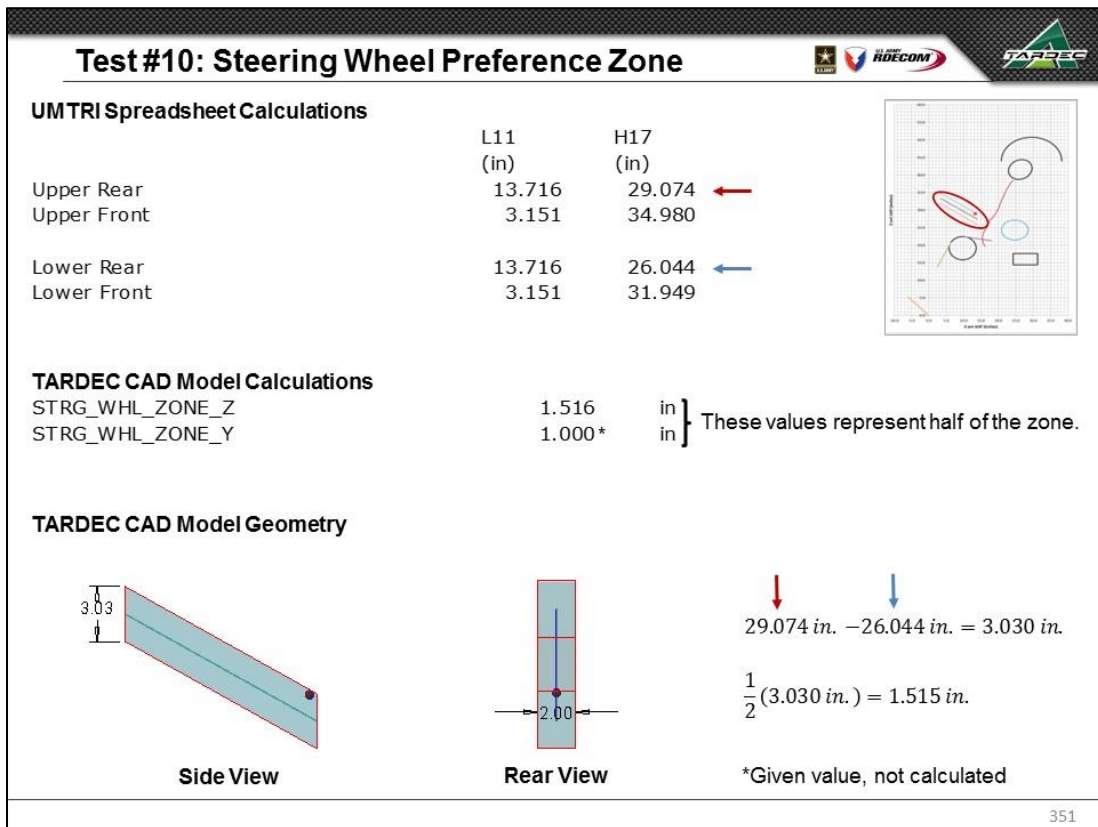
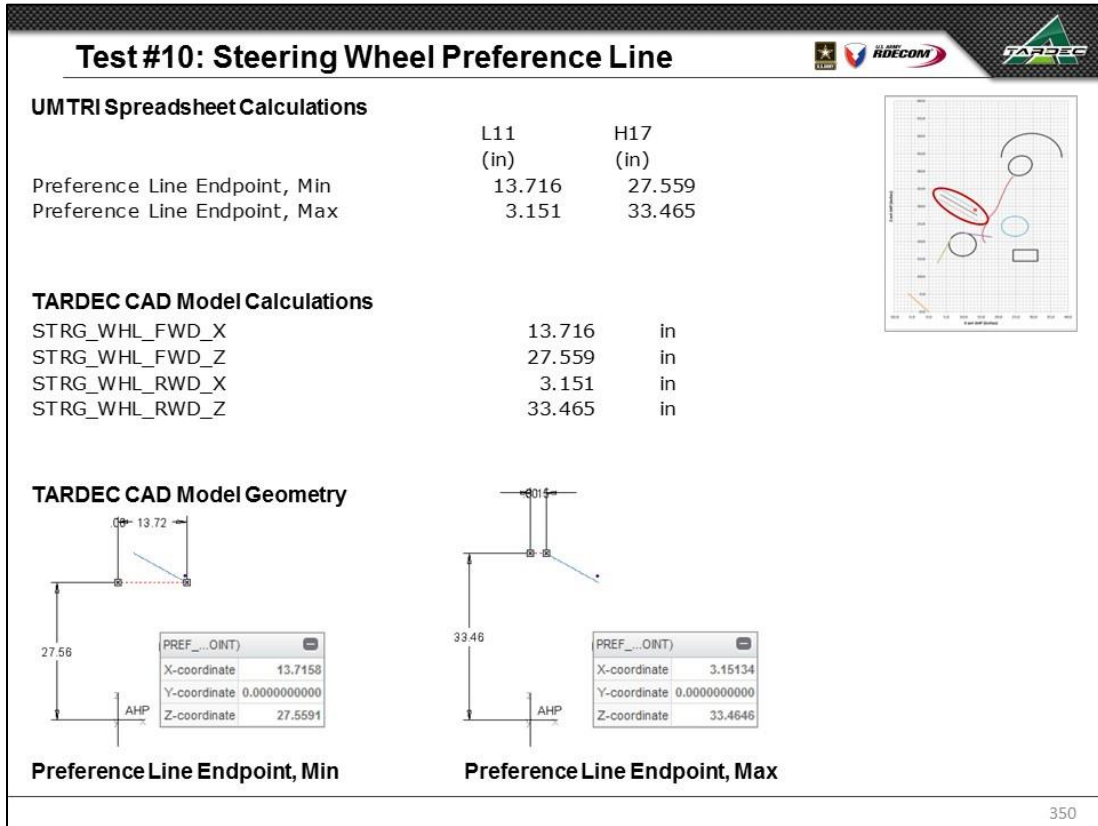

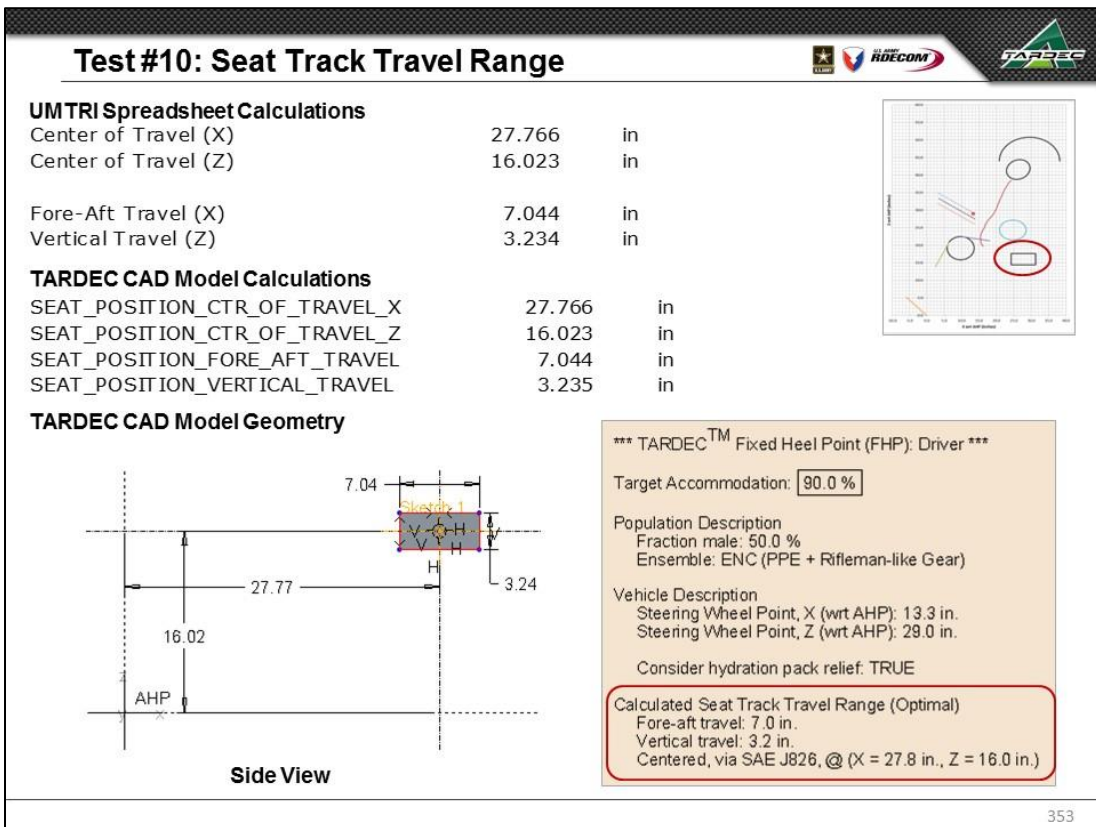
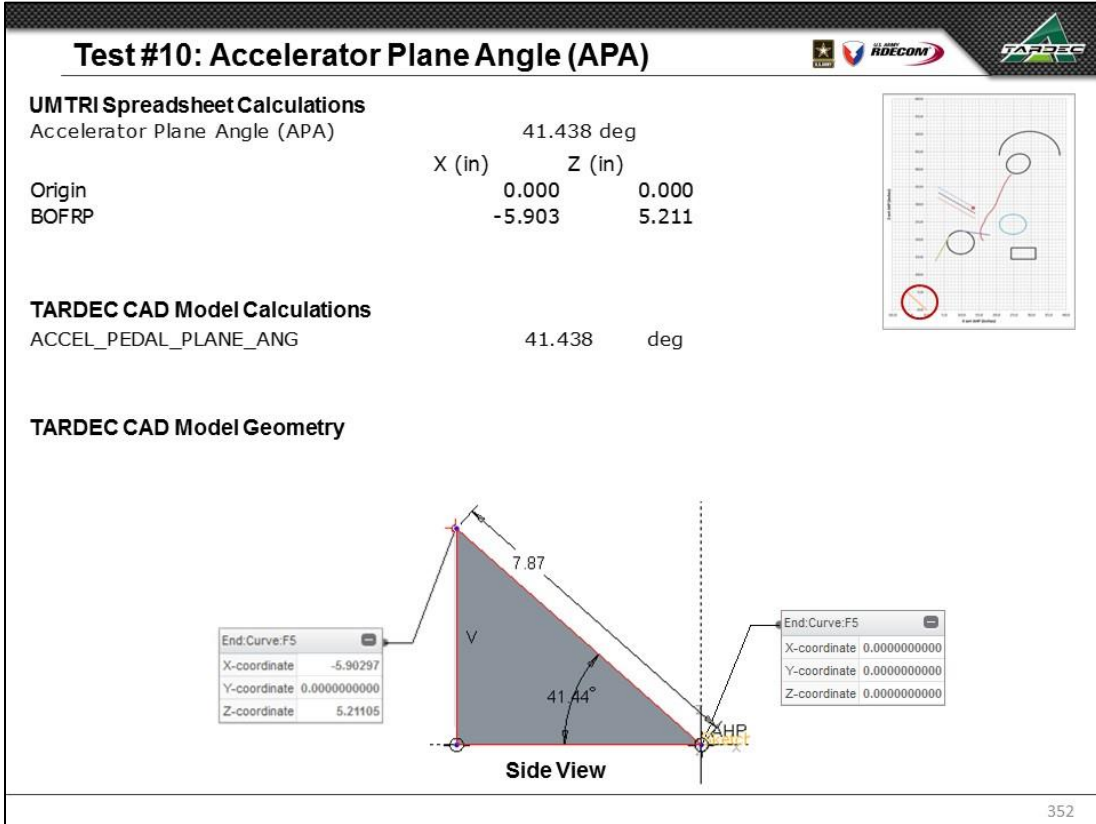

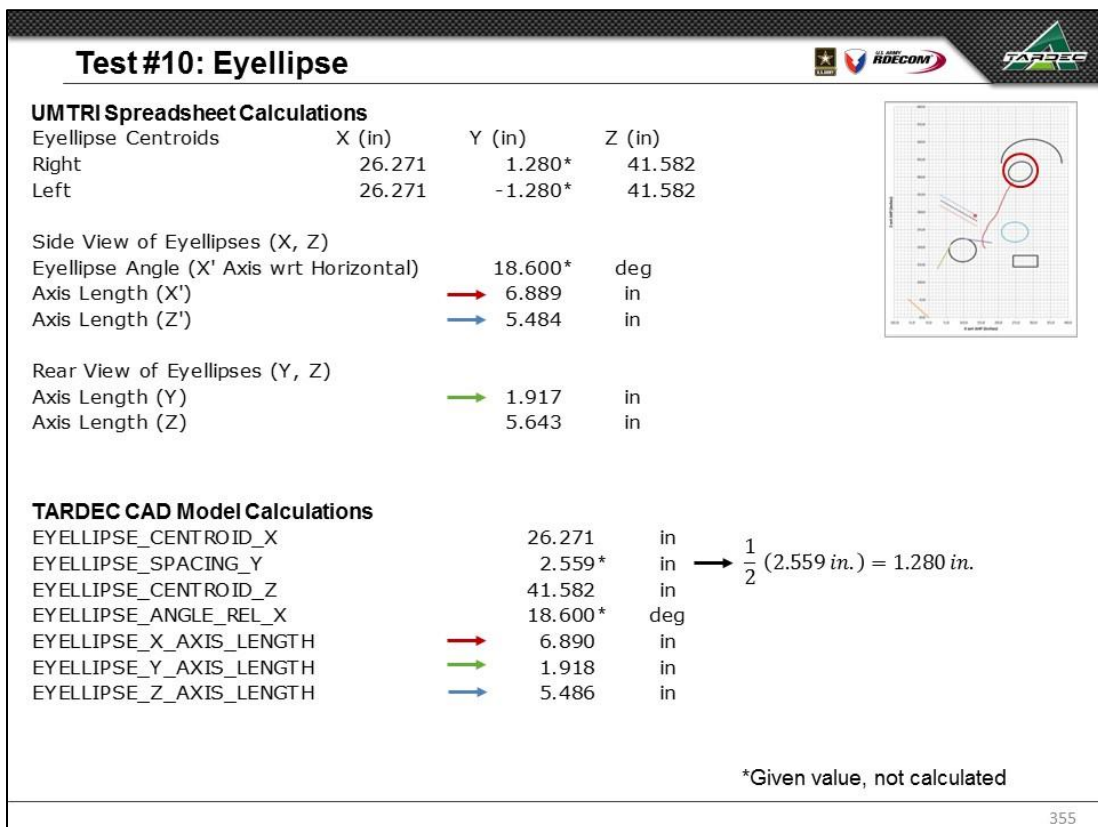
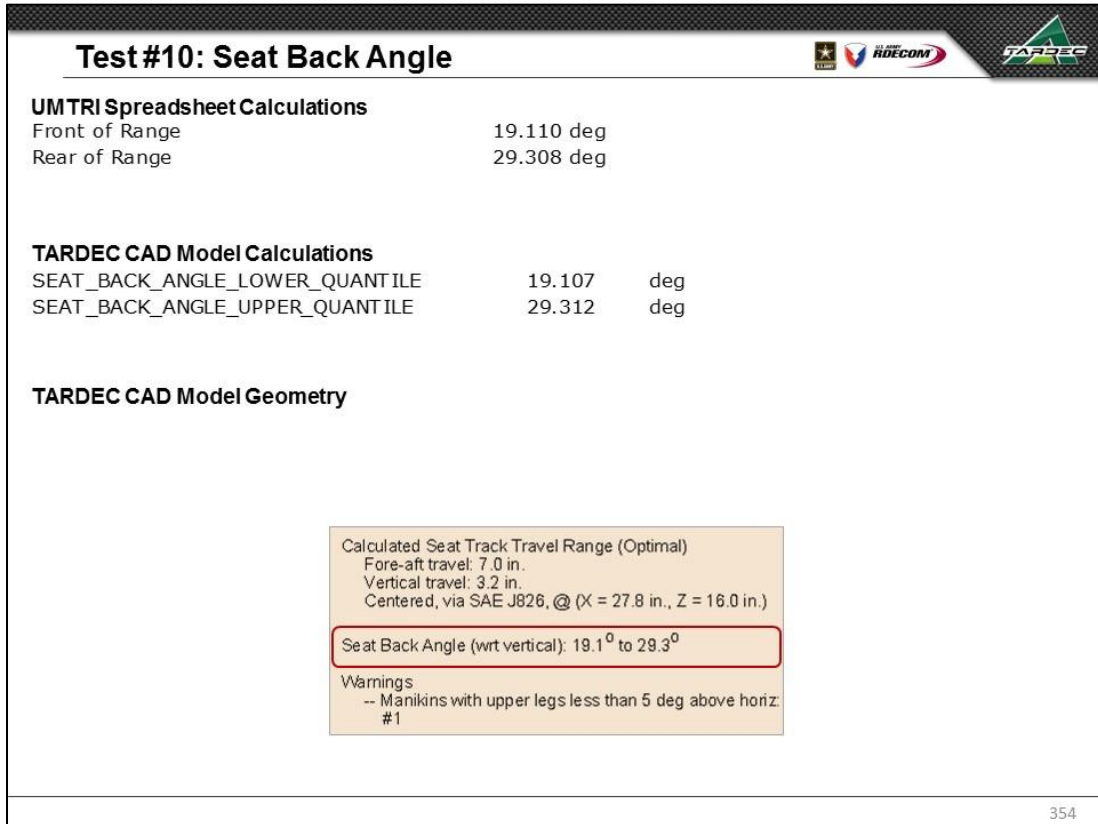

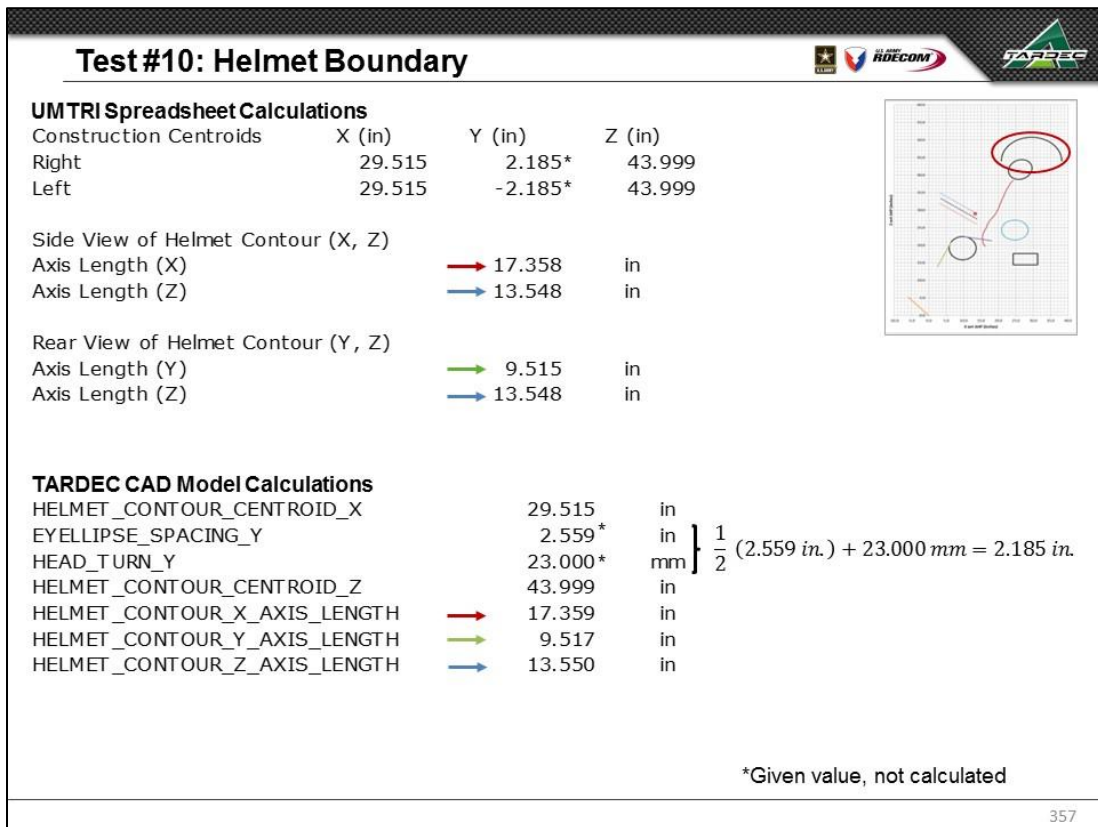
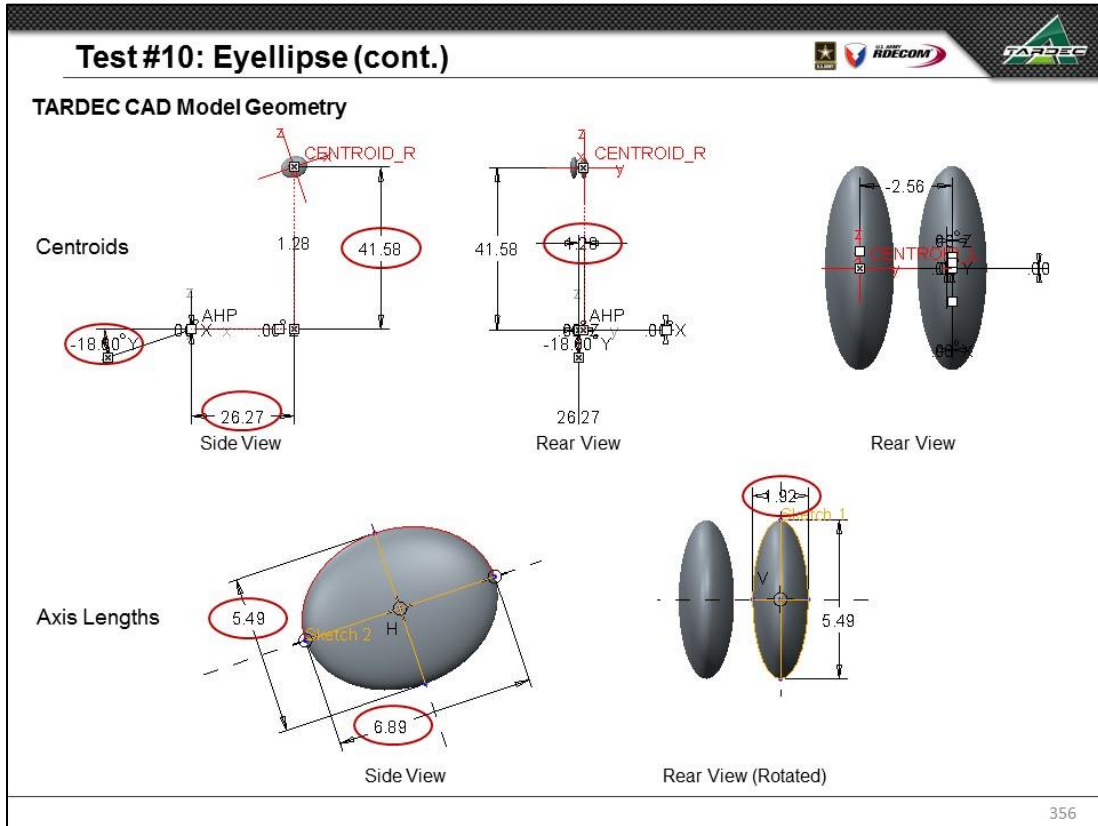

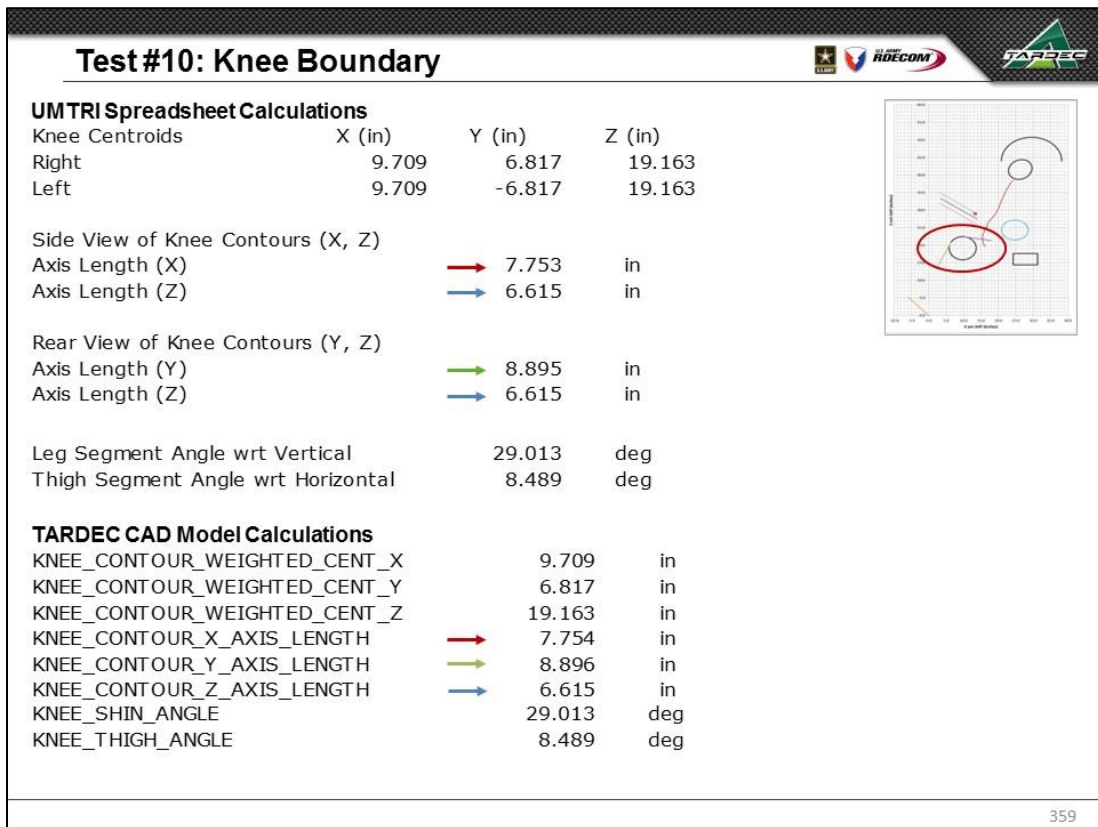
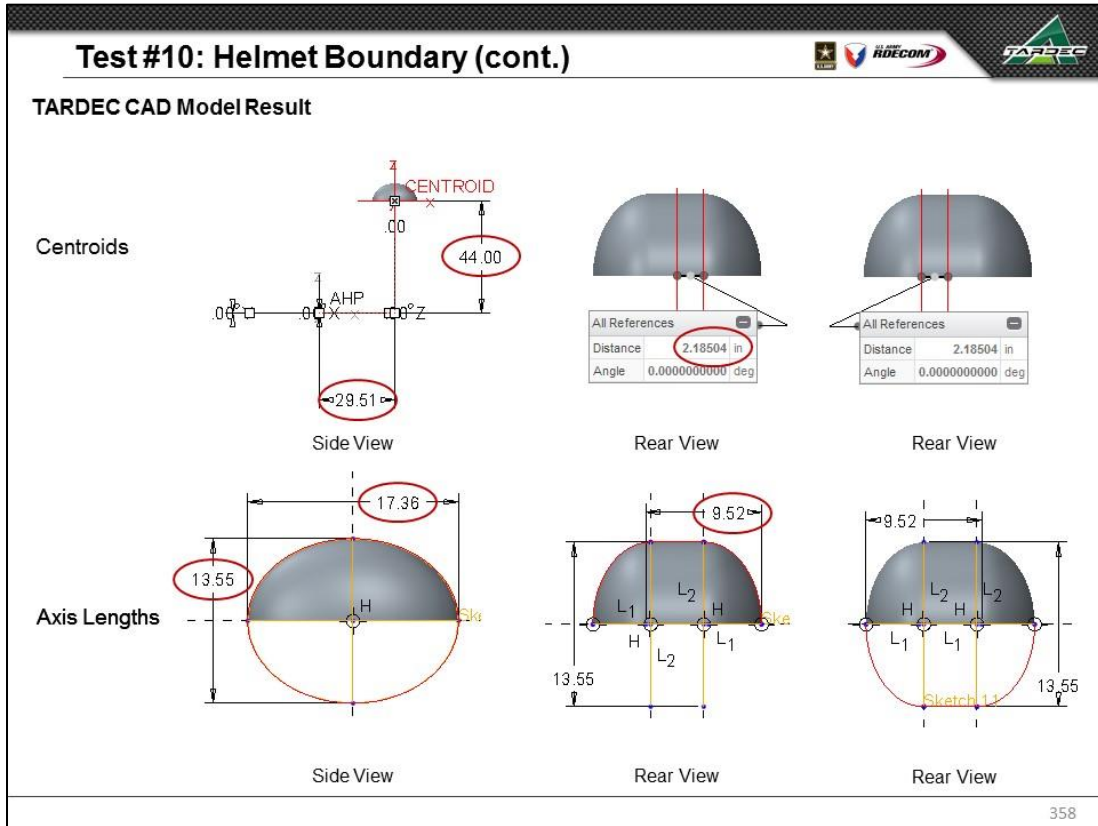

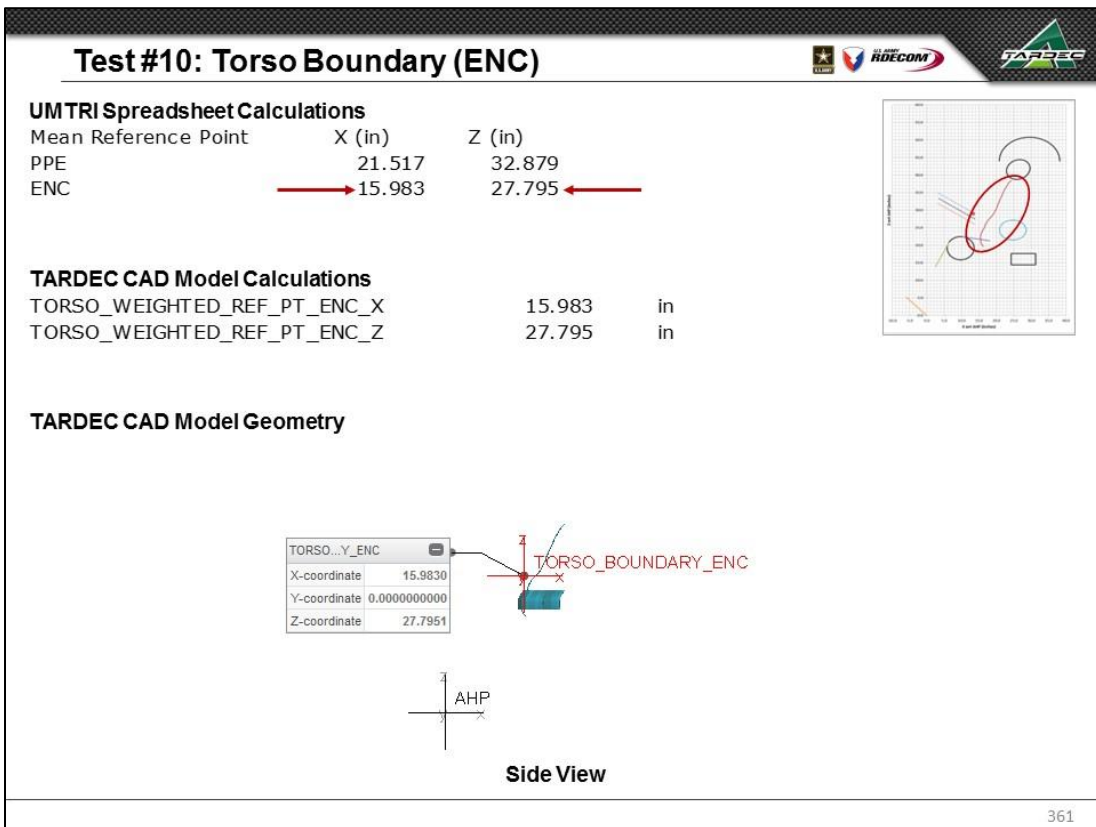
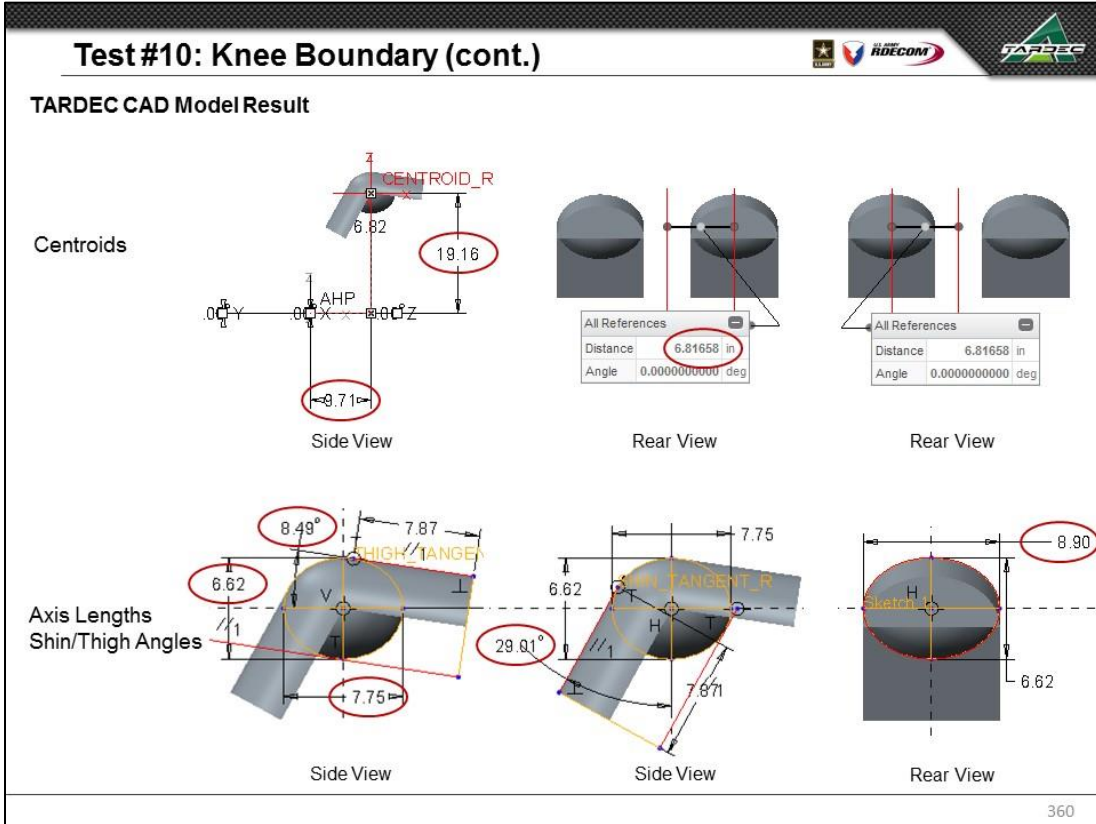

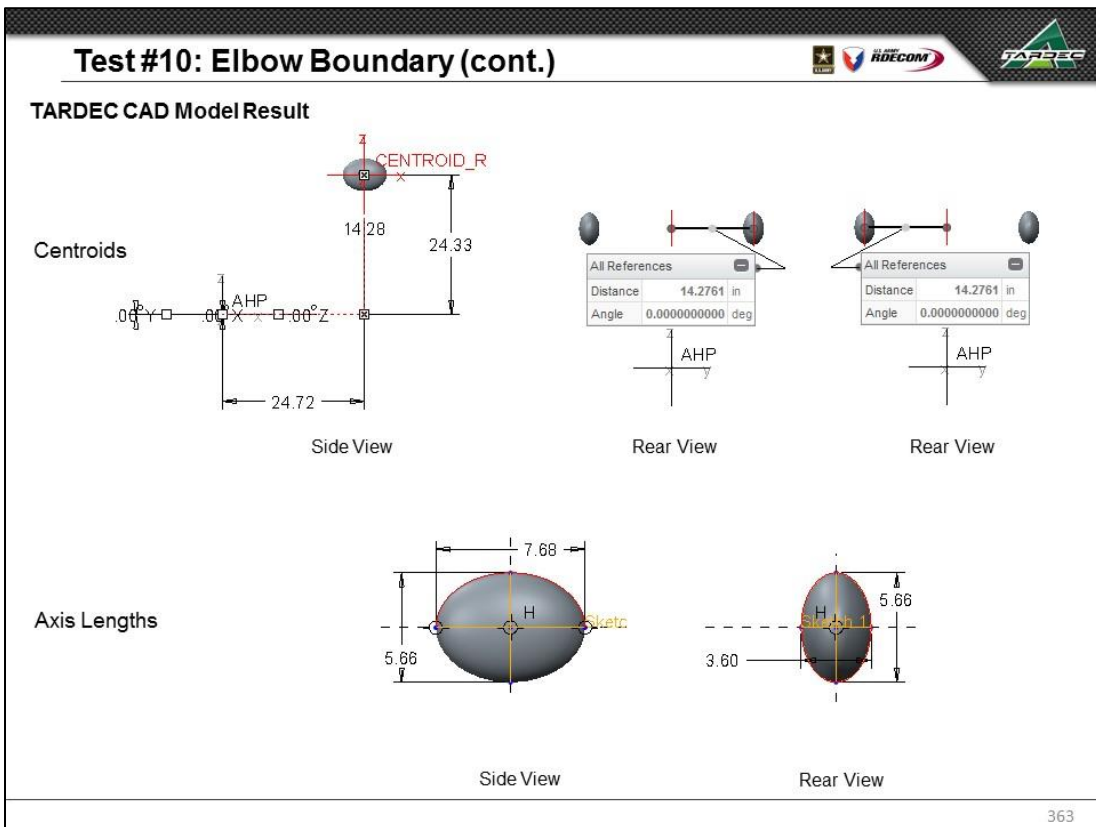
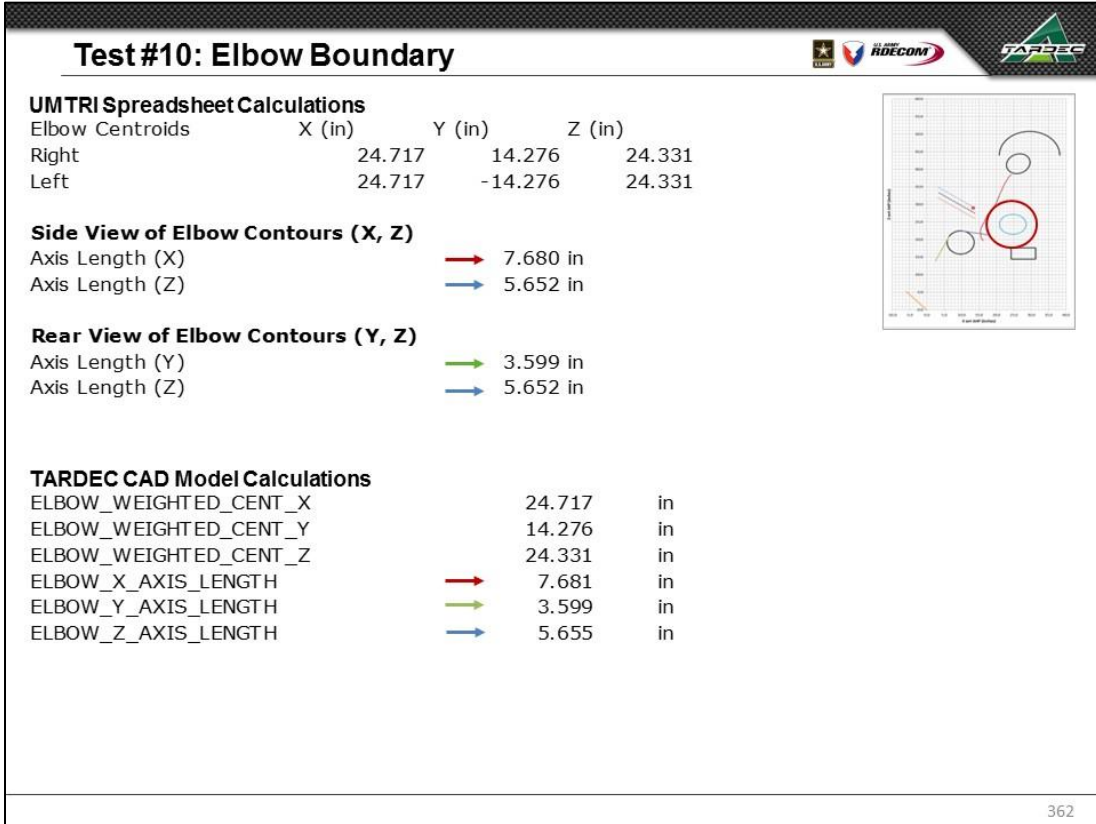



Test #10: Vary Gender Mix, Ensemble, and Provide Hydration Pack Relief

Target Accommodation	Fraction Male	Ensemble	Steering Wheel Point (SWP) (measured wrt AHP)		Hydration Pack Relief Availability	HARP Measurement Tool
			X (in.) (L11, fore-aft)	Z (in.) (H17, vertical)		
90%	50%	ENC	13.3	29.0	Yes	SAE J826

Clearance (2.0 inches), Shown in Yellow



TARDEC CAD Model

364

Test #10: Clearance, Helmet Boundary

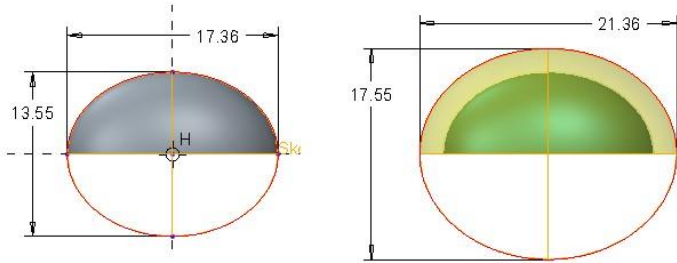

Sample Calculation: $\frac{1}{2} (21.359 \text{ in.} - 17.359 \text{ in.}) = 2.000 \text{ in. clearance}$

Side View

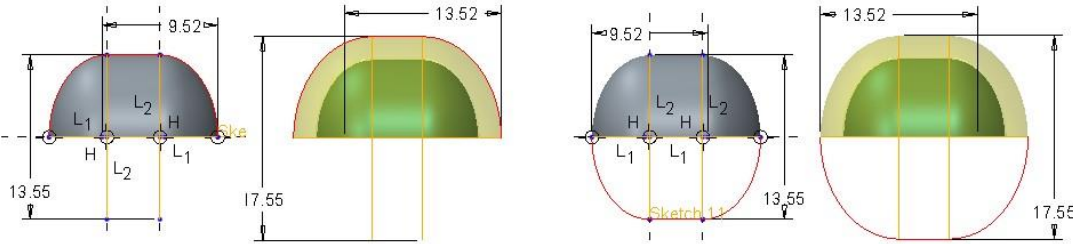

Rear View

365

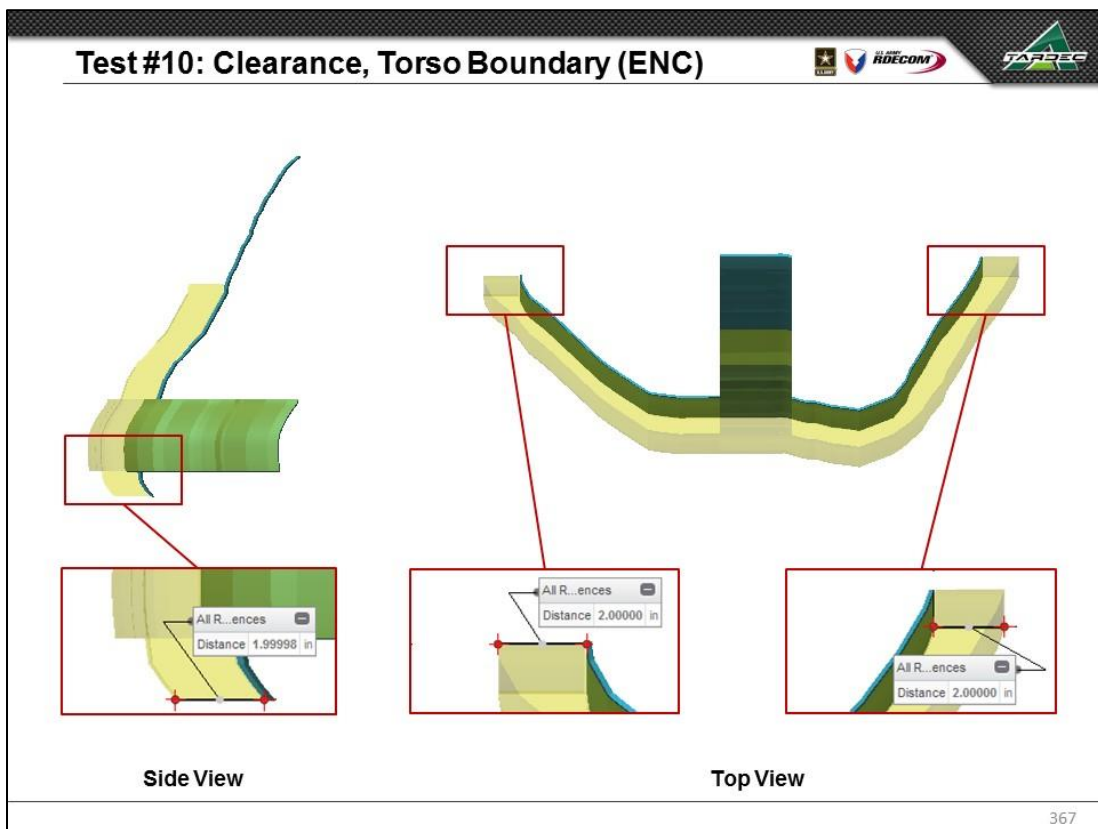
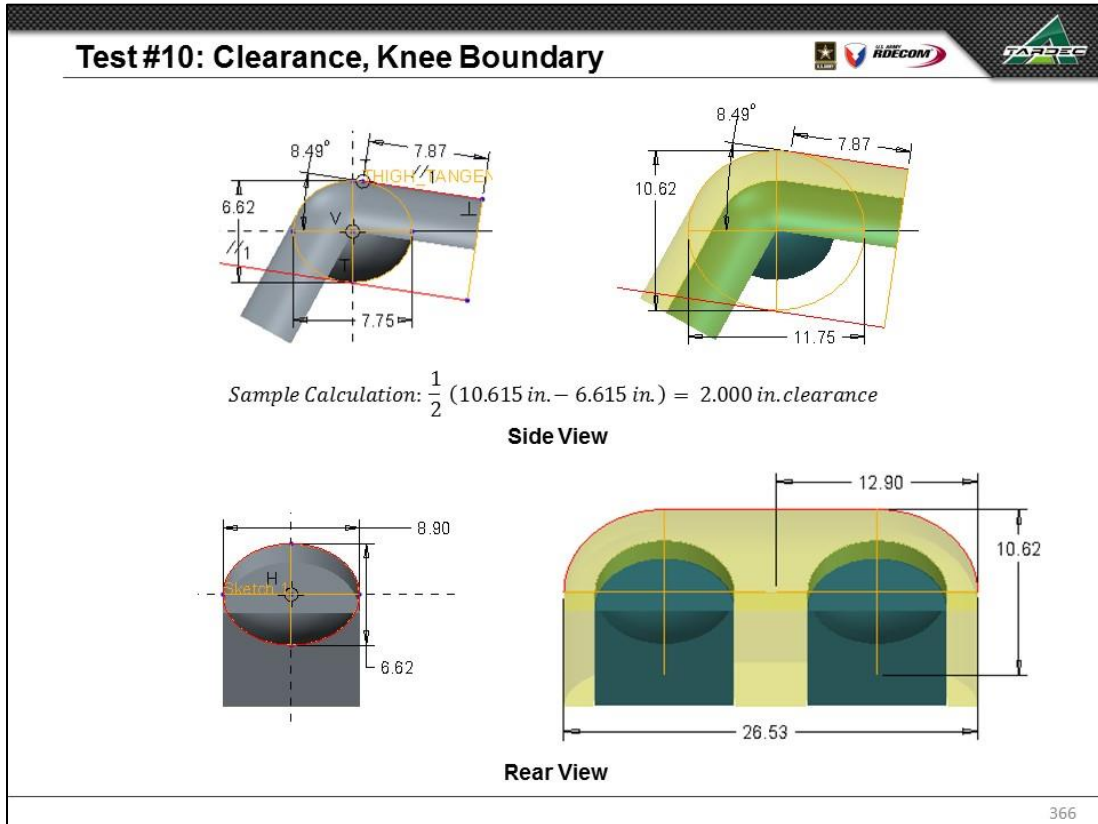

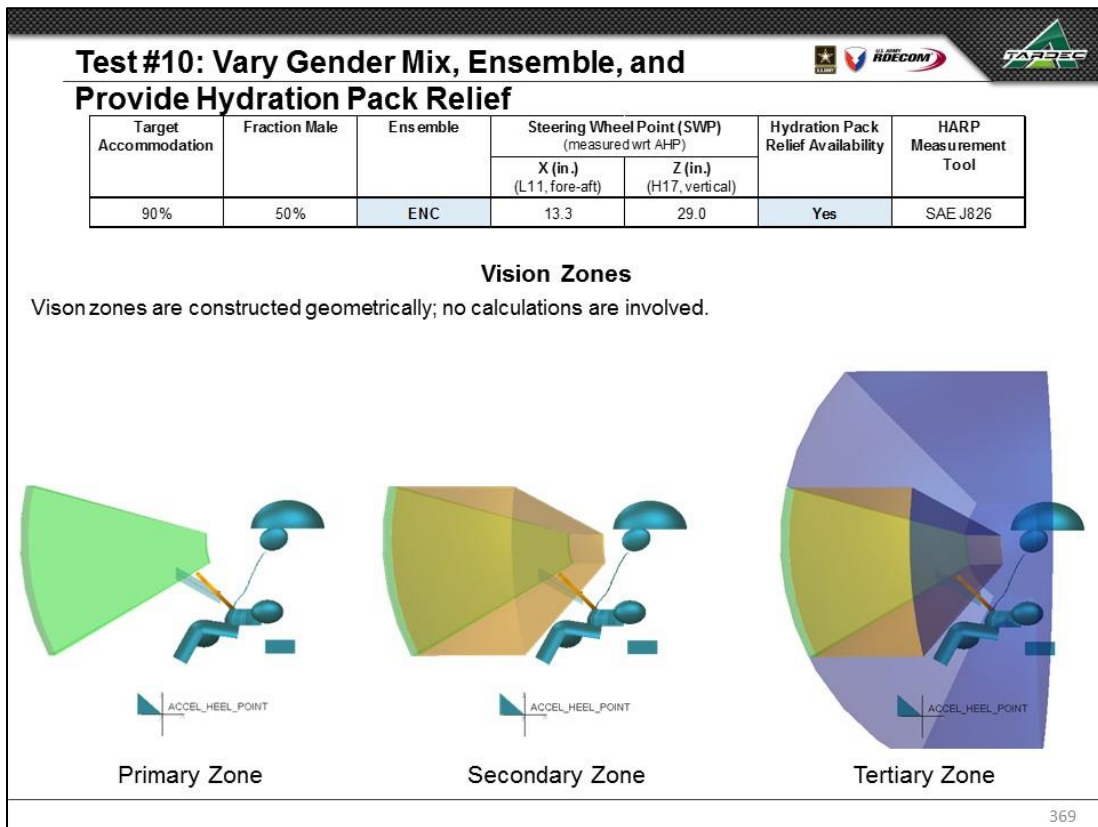
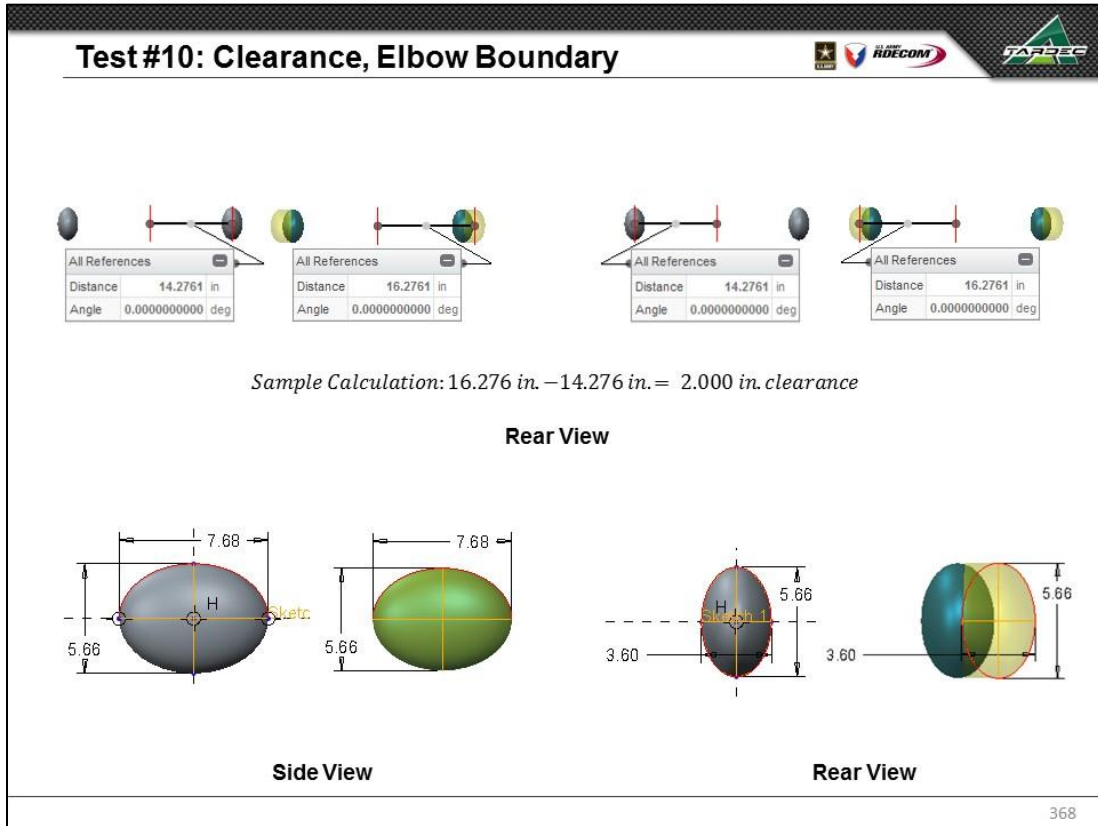

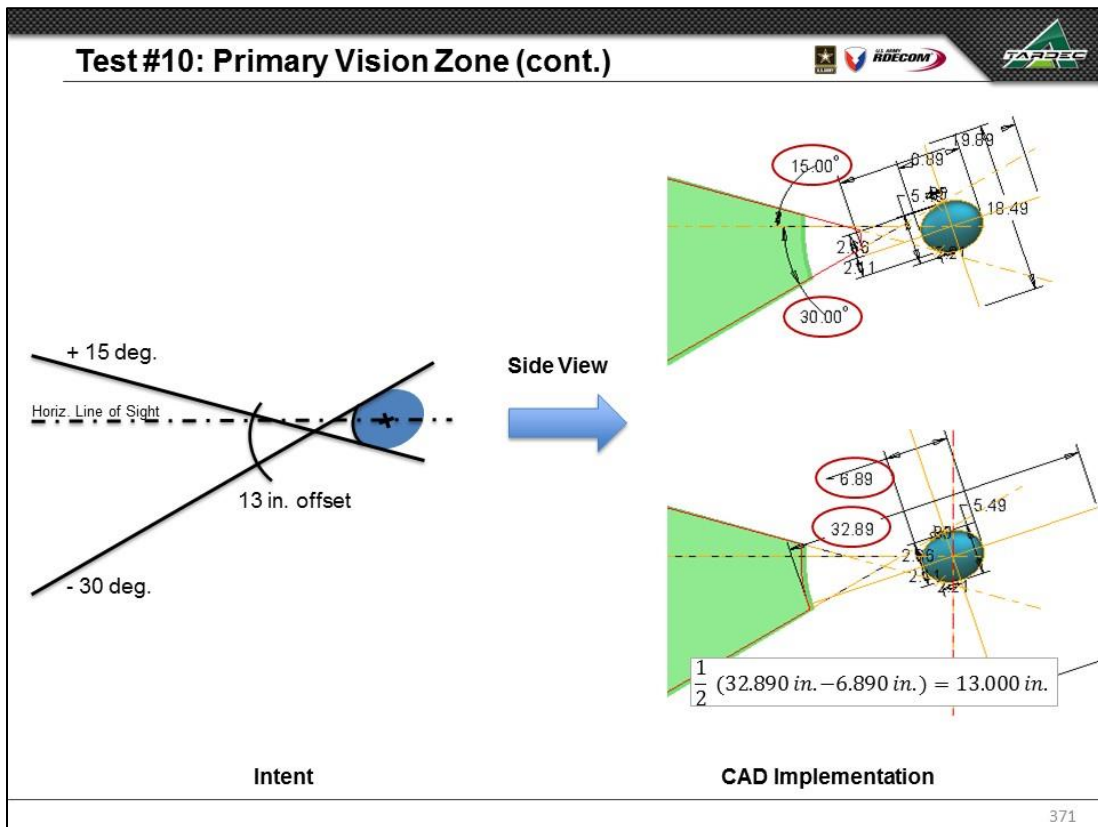
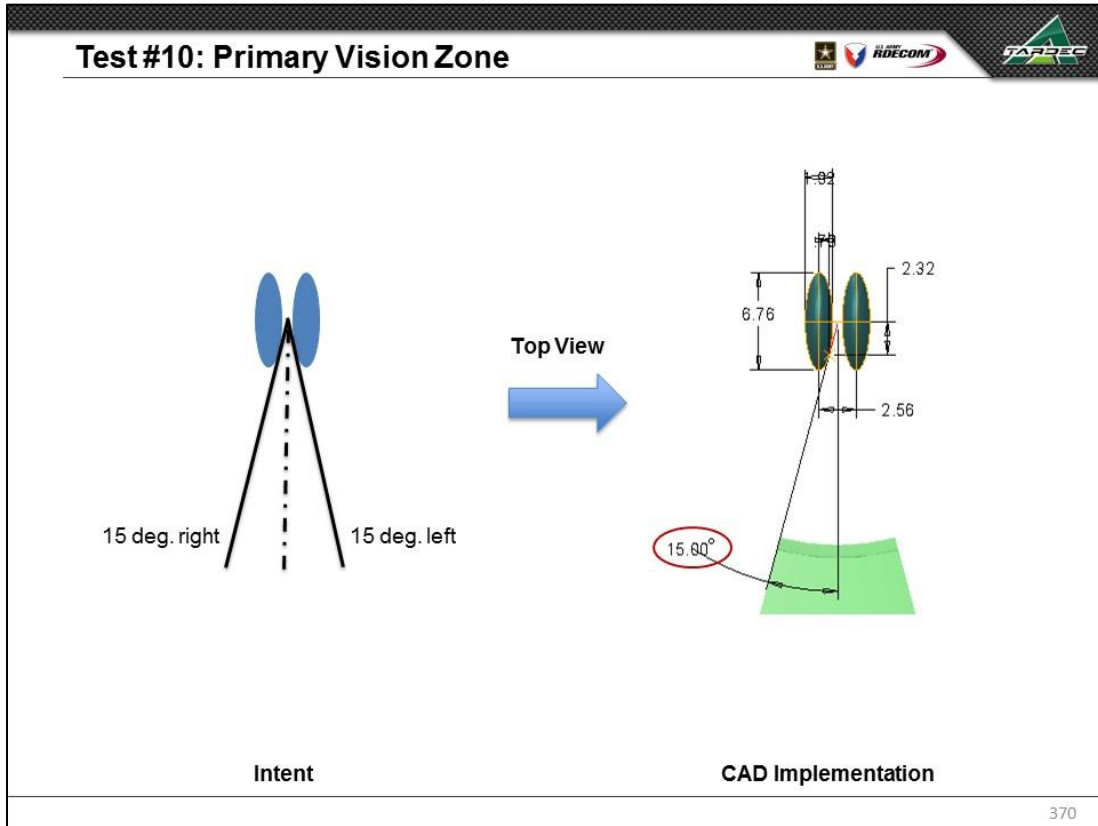

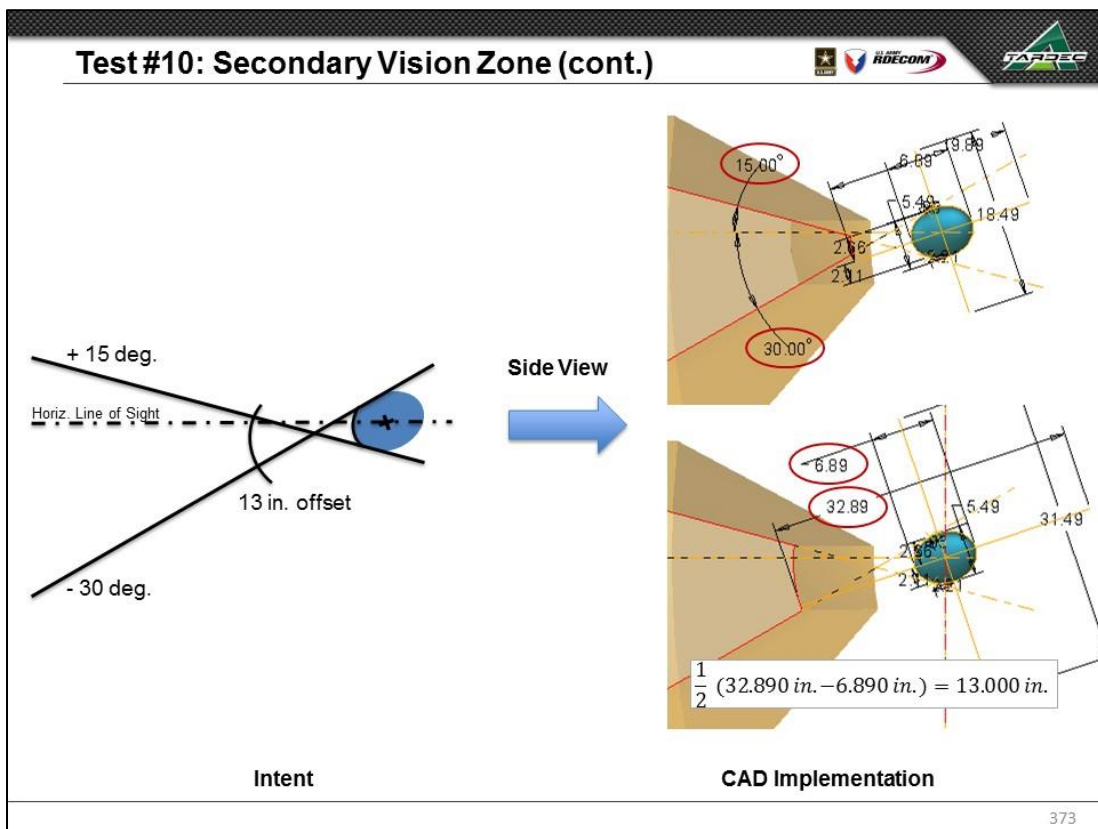
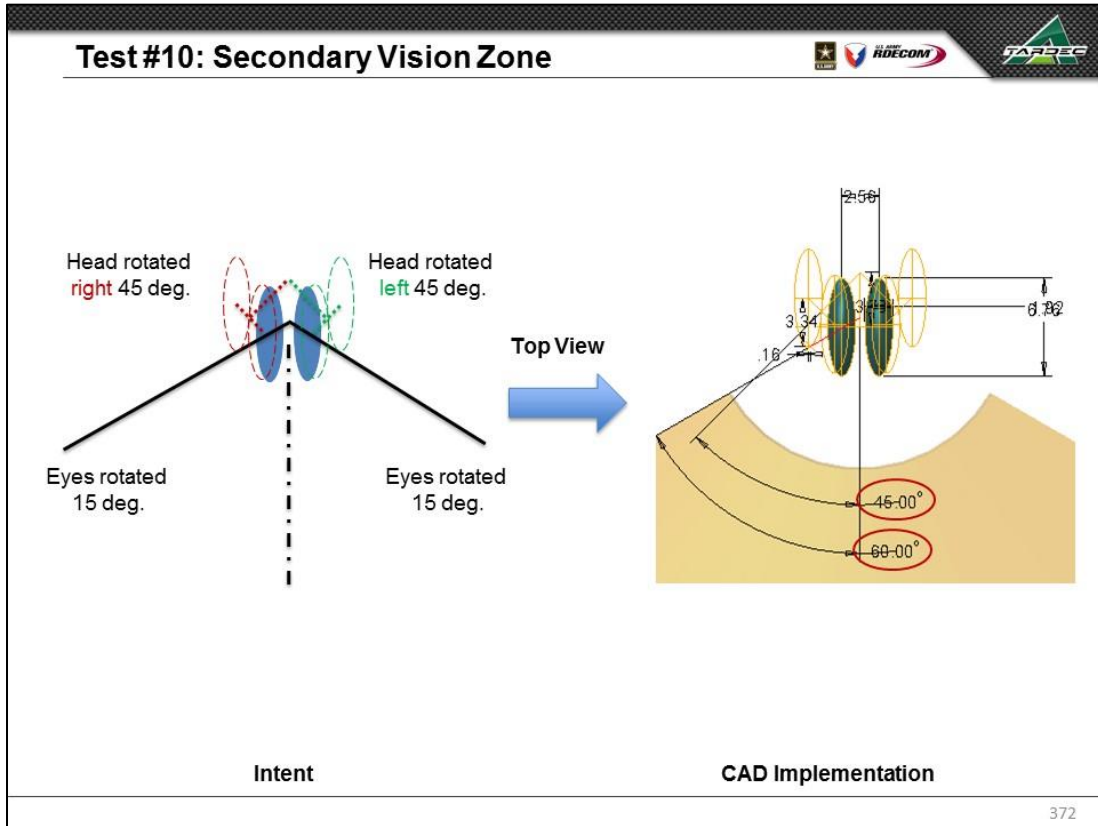



Test #10: Vary Gender Mix, Ensemble, and Provide Hydration Pack Relief



Target Accommodation	Fraction Male	Ensemble	Steering Wheel Point (SWP) (measured wrt AHP)		Hydration Pack Relief Availability	HARP Measurement Tool
			X (in.) (L11, fore-aft)	Z (in.) (H17, vertical)		
90%	50%	ENC	13.3	29.0	Yes	SAE J826

Boundary Manikin Posture and Position



TARDEC CAD Model

376

Test #10: Numerical Results, Manikin Positioning



Small Overall Female			
	UMTRI Value	TARDEC Value	Difference
POSTURE_DHM1_HIP_X	23.660 in	23.660 in	0.000 in
POSTURE_DHM1_HIP_Z	15.879 in	15.879 in	0.000 in
POSTURE_DHM1_EYE_X	24.940 in	24.940 in	0.000 in
POSTURE_DHM1_EYE_Z	38.171 in	38.171 in	0.000 in
Small Overall Male			
	UMTRI Value	TARDEC Value	Difference
POSTURE_DHM2_HIP_X	25.782 in	25.782 in	0.000 in
POSTURE_DHM2_HIP_Z	15.989 in	15.989 in	0.000 in
POSTURE_DHM2_EYE_X	26.191 in	26.191 in	0.000 in
POSTURE_DHM2_EYE_Z	39.938 in	39.938 in	0.000 in
Average Size Male			
	UMTRI Value	TARDEC Value	Difference
POSTURE_DHM3_HIP_X	27.977 in	27.977 in	0.000 in
POSTURE_DHM3_HIP_Z	15.988 in	15.988 in	0.000 in
POSTURE_DHM3_EYE_X	27.599 in	27.599 in	0.000 in
POSTURE_DHM3_EYE_Z	42.162 in	42.162 in	0.000 in
Widest Shoulders Male			
	UMTRI Value	TARDEC Value	Difference
POSTURE_DHM4_HIP_X	28.985 in	28.986 in	0.000 in
POSTURE_DHM4_HIP_Z	15.977 in	15.977 in	0.000 in
POSTURE_DHM4_EYE_X	28.255 in	28.256 in	0.000 in
POSTURE_DHM4_EYE_Z	43.440 in	43.440 in	0.000 in
Longest Torso Male			
	UMTRI Value	TARDEC Value	Difference
POSTURE_DHM5_HIP_X	28.229 in	28.229 in	0.000 in
POSTURE_DHM5_HIP_Z	15.971 in	15.971 in	0.000 in
POSTURE_DHM5_EYE_X	27.765 in	27.765 in	0.000 in
POSTURE_DHM5_EYE_Z	44.441 in	44.441 in	0.000 in
Longest Legs Male			
	UMTRI Value	TARDEC Value	Difference
POSTURE_DHM6_HIP_X	30.501 in	30.502 in	0.000 in
POSTURE_DHM6_HIP_Z	16.042 in	16.042 in	0.000 in
POSTURE_DHM6_EYE_X	29.176 in	29.176 in	0.000 in
POSTURE_DHM6_EYE_Z	42.661 in	42.661 in	0.000 in
Large Overall Male			
	UMTRI Value	TARDEC Value	Difference
POSTURE_DHM7_HIP_X	30.327 in	30.327 in	0.000 in
POSTURE_DHM7_HIP_Z	16.139 in	16.139 in	0.000 in
POSTURE_DHM7_EYE_X	28.932 in	28.932 in	0.000 in
POSTURE_DHM7_EYE_Z	44.400 in	44.400 in	0.000 in

TARDEC CAD values to agree with UMTRI spreadsheet values within
 ±0.100 inches
 ±0.100 degrees

Largest Observed Differences:
 0.000 inches

Values in agreement

377

