

Contract Number: W81XWH-17-P-0022
Support the (TCCCR) Task Area for Research and Development
of Medical Equipment to Clear and Maintain a Combat Airway

**A Report on Deliverable Six:
Develop a Concept Design for a Ruggedized,
Lightweight, Portable, Powered Handheld
Suction Device**

Report Authors:

Ricardo Pescador, BSME¹

Michael Lasch, MSME¹

Yusheng Feng, PhD¹

Robert A. De Lorenzo, MD, MSCI, MSM, FACEP²

¹Department of Mechanical Engineering, University of Texas at San Antonio

²Department of Emergency Medicine, UT Health San Antonio

27 September 2017

Table of Contents

Objective of the Report.....	4
Background.....	4
<i>Summary of the Background Section</i>	5
<i>Recommendations of Background Section</i>	5
Specifications and Design Considerations.....	5
Brief Design Considerations.....	6
Theoretical Pump and Vacuum Concepts.....	6
Flow and Vacuum Relationship.....	7
Specifications and Functional Requirements.....	9
Prime Mover (Pump) Options.....	9
Power Source (Battery) Selection Criteria.....	10
Electronics and Controller Criteria.....	11
<i>Printed Circuit Board</i>	12
<i>Micro-controller and Motor-controller</i>	12
Miscellaneous Considerations.....	13
Prior Art.....	13
Intellectual Property and Patent Overview.....	13
General Information and Device Usability.....	14
Pressure display and Suction Adjustment.....	14
Performance.....	15
<i>Pump</i>	15
<i>Power Consumption and Display</i>	15
<i>Specification Comparison</i>	16
<i>Cost and Current Use</i>	17
<i>Prior Art Conclusion</i>	17
Relevant ISO Standard (ISO 10079-1).....	17
Pump Performance and Suction Rate.....	17
Weight.....	17
Hose Assembly.....	17
Noise Level.....	18
Power Supply.....	18

Display and Indicators 18

Operation and Storage Conditions 18

Suction Rate..... 18

Summary and Conclusions..... 19

Acknowledgements..... 20

Appendix A - Key Task of the Report..... 21

Appendix B - Technical Approach 22

Appendix C – Concept Design Schematic Drawing..... 24

Appendix D – Parts List..... 25

Objective of the Report

Develop a concept design for a ruggedized, lightweight, portable, powered handheld suction device that is capable of quickly and fully clearing fluid and debris from the airway of a combat casualty. The concept should meet the following fundamental requirements: 1) Portable, 2) Lightweight, 3) Battery Powered, 4) Easily decontaminated from body fluids, 5) operable in anticipated environmental conditions (per Mil Std), and 6) be certifiable airworthy (per Mil Std). Deliverables will be: A report of a design concept including basic design specifications, appropriate sketches, identification of key parts and costs, and discussion of existing patent issues that affect the design.

Background

[Readers are referred to the following for a more detailed overview and background on portable suction for use in prehospital combat casualty care: *A Report on Deliverable One: Determine Required Performance Characteristics [of Suction] for Management Of Prehospital Combat Casualty Care Injuries*. Contract Number: W81XWH-17-P-0022 Support the (TCCCR) Task Area for Research and Development of Medical Equipment to Clear and Maintain a Combat Airway. Report Author: Robert A. De Lorenzo, MD, MSCI, MSM, FACEP, Department of Emergency Medicine, UT Health San Antonio, February 22, 2017.]

Tactical airway management often determines survival in both trauma and medical patients. Skilled interventions often make the critical difference in survival for patients with actual or impending airway compromise. Managing airways in the tactical environment presents an additional level of unique and complex challenges for any emergency provider. Hazardous or confined spaces and hostile action inherently limit the ability to intervene with an artificial airway or assisted ventilation. Loss of patient airway in tactical and combat environments commonly occurs. The proximate cause can be direct trauma to the airway structures or indirectly from traumatic shock or brain injury and the subsequent loss of airway protective reflexes.

There is limited information on the types, if any, of portable suction units carried by combat medics in the far-forward combat area. Anecdotal information suggests that powered suction devices are simply too heavy to be carried in the combat medic's aid kit. Manual powered devices, while lightweight, offer limited capability and require the use of a hand or foot to operate, limiting efficiency of the provider. Fielding data from military logistics agencies on the number and types of suction units employed in the field is not available, and prior experience suggests even if obtained, the data shows only total purchases and not where and when fielded.

Existing portable suction standards are civilian-oriented, lack a detailed base of evidentiary support, and in any case do not satisfy the critical needs of combat casualty care. Importantly, there is little data on the safety of suction units used in this setting. We will review the available literature and guidelines on suction safety with an emphasis on the maximum pressure that can be safely applied to sensitive tissue without causing harm. We will also propose a protocol draft that can be used to safety-test a suction device.

Of note, this report will focus on the safety of the patient, and not the safety aspects of the operator. That is, the operator bears some risks such as exposure to blood and body fluids by accomplishing the task of patient suctioning. This will not be addressed.

Summary of the Background Section

- The required specifications for suction devices is not well studied and there are no guidelines specific to the prehospital combat use.

Recommendations of Background Section

- The military services should generate a requirement for suction devices for use in the prehospital combat environment.

Specifications and Design Considerations

[For a detailed review of specifications and design considerations, readers are referred to A Report on Deliverable Four: Develop a Specifications List for a Portable, Lightweight Prehospital Suction Device. Contract Number: W81XWH-17-P-0022 Support the (TCCCR) Task Area for Research and Development of Medical Equipment to Clear and Maintain a Combat Airway. Report Author: Robert A. De Lorenzo, MD, MSCI, MSM, FACEP, Department of Emergency Medicine, UT Health San Antonio, September 14, 2017.]

Brief Design Considerations

A portable suction device is a medical device intended to maintain a human's airway clear of any obstructions (refer to Figure). Said obstructions include vomit, debris, and fragmentation. This medical device is intended to be used in a military environment.

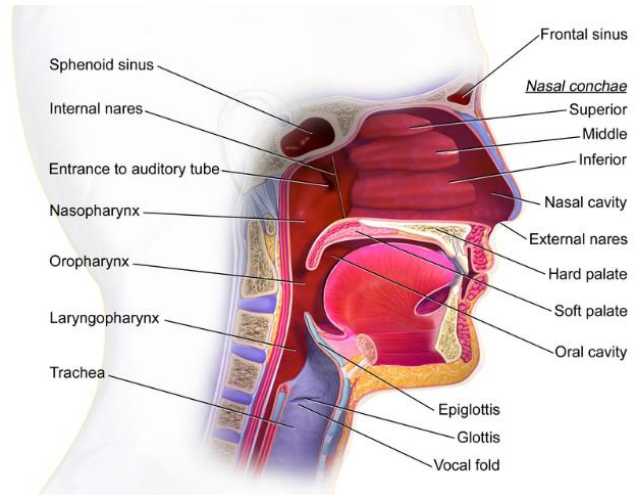

FIGURE: Upper Respiratory

Tract

Photo Credit: Blausen.com staff (2014). "Medical gallery of Blausen Medical 2014". WikiJournal of Medicine 1 (2). DOI:10.15347/wjm/2014.010. ISSN 2002-4436.

Theoretical Pump and Vacuum Concepts

Pumps

- Mechanical devices used to suction, increase pressure or move liquids or gases.
- Pumps can be configured for vacuum, pressure and vacuum-pressure purposes.

Pumps in Series

- Pressure head doubles when compared to one operating pump.
- Flow rate remains the same when compared to one operating pump.

Pumps in Parallel

- Flow rate doubles when compared to one operating pump.
- Pressure head remains the same when compared to one operating pump.

Figure: Pumps in series and parallel

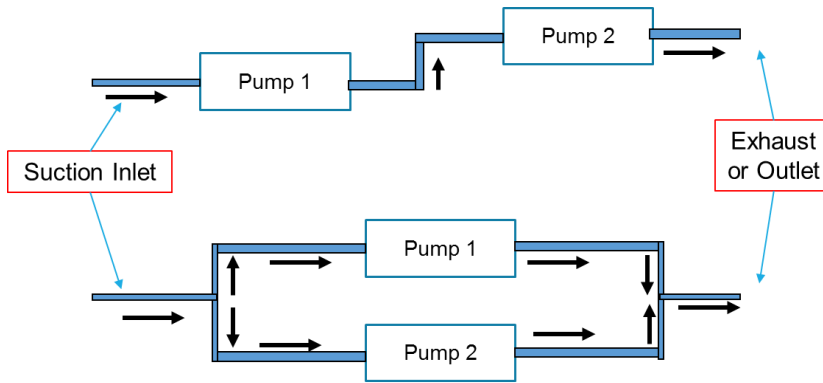

Note: Pump 1 and 2 are Identical Pumps

Flow and Vacuum Relationship

Figure: Pressure – Flow Relationship

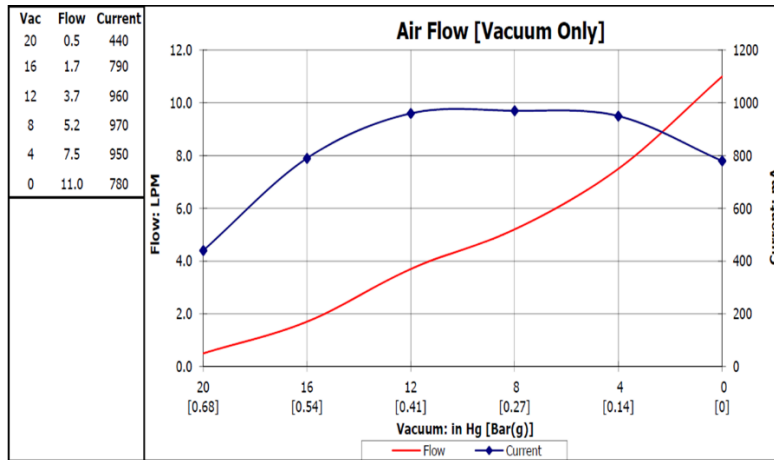

Therefore :

$$Pressure_{vacuum} \propto \frac{1}{Flow\ Rate}$$

- As Vacuum increases flow rate decreases

The current concept design is depicted in the figure. This design utilizes a pump as the mechanism to suction obstructions out of a person’s airway, an inline hydrophobic filter and a collection canister. The inline hydrophobic filter is intended to protect the pump from any contaminants and also restricts the passage of any fluid to the air pump. Inherently, this makes the pump reusable while the filter, canister and tubing require replacement after usage. The concept design also has an on/off switch, a low battery LED and a potentiometer to regulate the pumping power. The control system of the device is composed of an Arduino Leonardo and a motor shield. Two power sources are used to power the entire device; a 12V battery is solely dedicated for the pump and a 9V battery powers the Arduino board. After examining the design concept it was determined that the device had the following deficiencies:



Figure: Prototype

- Low suction; higher suction is desired
- Large footprint and heavy; smaller portable device is desired
- A large canister which gives it a large footprint
- Requires two separate batteries to operate
- Utilizes a hydrophobic filter which provides a large pressure drop and restricts flowrate

Figure: Concept design, with setup for bench testing.

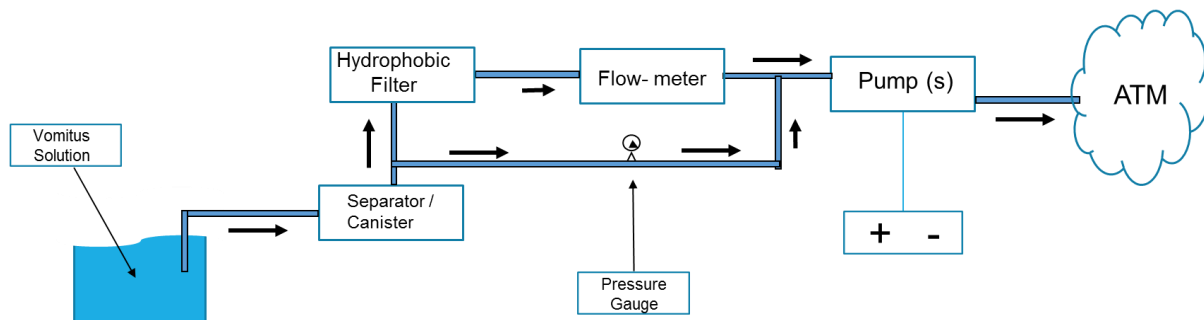

Specifications and Functional Requirements

A detailed review of the functional requirements for improvement is described in this section.

Prime Mover (Pump) Options

Commercial off-the-shelf rotary pumps are available in a variety of sizes and configurations. Two representative examples are shown.

Rotary Vane Pump G 07

Flow	21 l/min
Max. pressure	1,4 bar
Max. vacuum	77 %

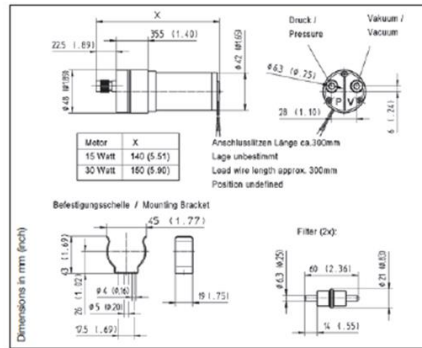

Pneumatic Data			
Description	G 12/07-15 Watt	G 24/07-15 Watt	G 24/07-30 Watt
Part number	50336	50218	50221
Max. flow	17,0 l/min	17,5 l/min	21,0 l/min
Max. intermittent pressure	1,3 bar	1,0 bar	1,4 bar
Max. continuous pressure	0,3 bar		0,2 bar
Max. intermittent vacuum	76 %	75 %	77 %
Max. continuous vacuum	30 %		20 %

Electrical Data			
Motor type	Permanent magnet	Permanent magnet	Permanent magnet
Nominal voltage	12 V DC	24 V DC	24 V DC
Min. current consumption	1,9 A	1,1 A	1,9 A
Max. current consumption	3,2 A	1,6 A	2,5 A
Protection class	IP40	IP40	IP40
Motor bearing	Ball bearing	Ball bearing	Ball bearing

General Data			
Ambient temperature	-10 to 40 °C	-10 to 40 °C	-10 to 40 °C
Weight	0,6 kg	0,6 kg	0,7 kg
Direction of rotation	cw	cw	cw

WOB-L Piston Vacuum Pump 8006ZV DC

Flow	31,0 l/min
Max. vacuum	80 %

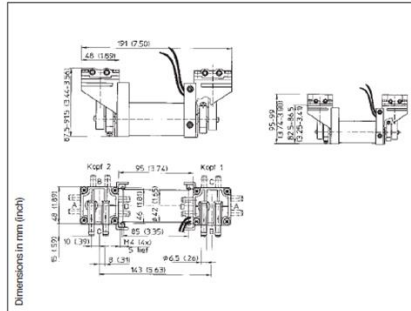
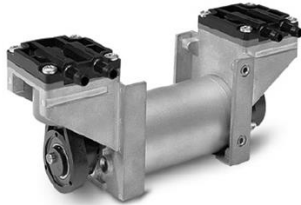

Pneumatic Data	
Description	8006ZV/30/4,5V/DC
Part number	80060131
	80060135
Max. flow	31,0 l/min
Max. vacuum	80 %
Max. restart vacuum	Ambient pressure
Electrical Data	
Motor type	Direct current
Nominal voltage	12 V/24 V DC
Nominal speed	2800 rpm
Power consumption	60 W
Motor insulation class	E
General Data	
Ambient temperature	10 to 40 °C
Media temperature	10 to 60 °C
Weight	0,93 kg
Port direction	CB
Configuration	parallel

Another pump option is provided at:

http://www.micropump.com/product_detail.aspx?ProductID=71. It has a removable impeller which means you could potentially use this pump without the filter; thus, providing an alternative design concept.

Power Source (Battery) Selection Criteria

Batteries containing the required power requirements and smaller in physical size will need to be obtained for the design concept. There are a wide variety of commercial off-the-shelf battery packs that can be used. If there is no generic power sources that meet the specified requirements under load, a custom-made batteries need to be considered.

Criteria of information needed:

- What is device's input voltage? (V)
- What is its power consumption (W)
- What is Maximum current drain (A)
- Decide Battery pack's Capacity (mAh or Ah)
- Calculation :

$$(Ah) = \text{Device's Wattage (W)} \times \text{Time to run (Hours)} / \text{Battery Voltage (V)}$$

A representative example of a commercial battery pack is shown.

Polymer Li-Ion Battery Pack: 14.8v 3650mAh (54.02 Wh, 7.0A rate) with PCM (4.38)



Your Price: \$80.95

In Stock

Product ID # 5878
Part Number: PL-5545135S4-WR

Lead Time: 5 Business Days

Quantity:

[Add to a new shopping list](#)

[Email this page to a friend](#)



*Important Shipping Regulation	This pack is for testing (prototype) only. It has not been UN38.3 tested yet. Read more...
Packing	<ul style="list-style-type: none"> Made by 4 Polymer Li-ion 3.7V3650 mAh (PL- 5545135-2C) Wrapped by heavy duty heat shrink tube Optional for 1 pc A Fire Retardant Bag: 295mmx230mmx75mm --- Reduce the chance of damage if caught fire <ul style="list-style-type: none"> This Fire Retardant Bag (Li-Ion Safer Bag) is intended to reduce the chance of damage in the event of catching fire. Must locate & seal the battery pack in the bag while charging / leaving without any attention
Voltage	14.8V (working) 16.8V (peak) 11.0V (cut-off)
Capacity	Nominal: 3650 mAh (54.02Wh)
Protection	<ul style="list-style-type: none"> One PCM with balance function (10A max.) is installed with the battery pack to protect battery from <ul style="list-style-type: none"> Over-charging beyond 4.25V/cell Over-discharging below 2.75V/cell Over-drain beyond 10A Must wait min of 30 minutes after battery is fully charged to allow the pcm to perform balance function on all the cells within the pack. 7 Amp polyswitch installed to limit max. discharging current and to protect wrong polarity
Pre-wired	6" wire with 18 AWG
Max. Discharging Rate	7 Amp limited by polyswitch (lower rate available upon request)
Dimensions(LxWxH)	5.8"(148mm) x 2.3"(58mm) x 1.7"(46mm)
Detail Data Sheet	 Please click here to download the specification
Weight	12.7oz. (360grams)

Electronics and Controller Criteria

Printed Circuit Board

A Printed Circuit Board (PCB) could replace the current state of the design concept which is composed of routed wires and electronic components; this will provide a more compact solution and will inherently enhance the manufacturing process. The following image illustrates the proposed design concept.

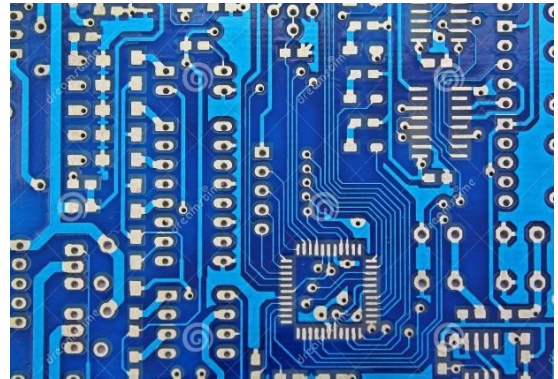
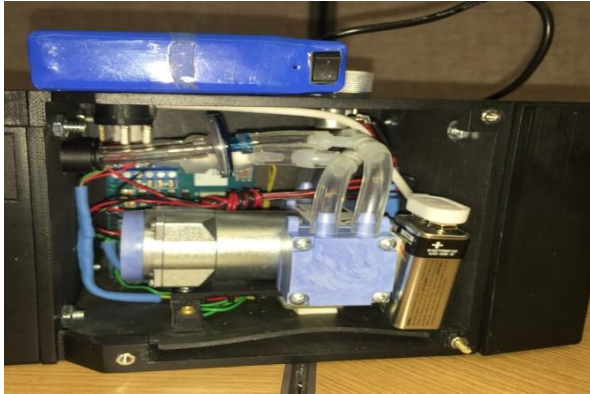

Figure: Printed Circuit Board

Micro-controller and Motor-controller

A relative large size micro- controller and motor-controller are currently used in the design concept. These components can be replaced by much smaller components such as the Adafruit-feather micro controller and motor shield. By implementing the suggested improvement, the resulting prototype will be lighter and compact in size. The power requirements of the device will also be decreased since the proposed micro-controller requires a much smaller and lighter power source. The following images represent the aforementioned improvements.

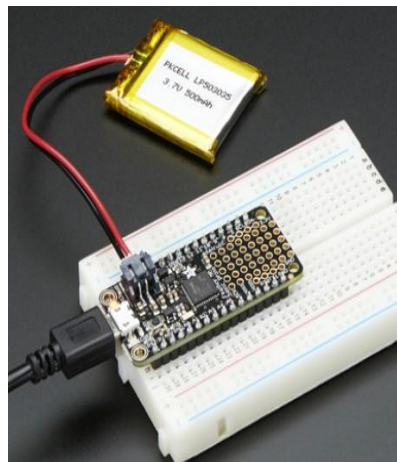

Figure: Micro Controllers

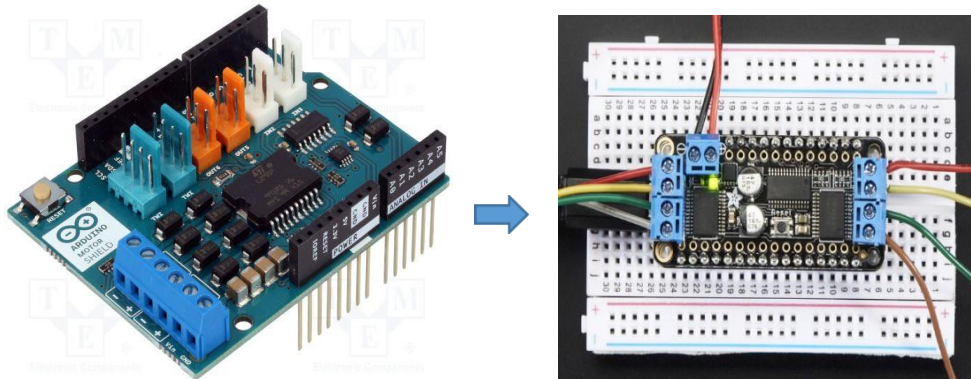

Figure: Motor Controllers

Miscellaneous Considerations

Miscellaneous areas of design consideration

- Pneumatic fittings to ensure vacuum is maintained
- Fluid lines to use with vacuum systems
- Pressure sensors and flow-rate sensors
- Solenoid valves
- Check valves
- Mufflers to reduce noise
- Other ways to obtain a strong vacuum (i.e. vacuum generators)



Prior Art

Intellectual Property and Patent Overview

A preliminary review of the United States Patent and Trademark Office (USPTO) database produced a list of 35 patents which are in the realm of intellectual property that deals with the portable airway device. Of those 35 patent and patent applications, 4 include claims concerning the portability of the device.

Three patents of particular interest are detailed below:

Patent US 4,930,997 (Bennett, 1990) which is granted for a portable medical suction device. This patent claims generation of a portable suction device that utilizes a power supply, motor, hydrophobic vent, housing, and vacuum generation apparatus. These claims all cover the development of a basic device which will generate suction via a portable device.

Patent US 7,063,688 (Say, 2006) which is granted for a portable battery powered aspirator. This device claims to have developed a battery powered device that will generate suction and have the ability to transport fluid into a removable storage container. This device is primarily designed to be an all in one aspiration device.

Patent US 5,776,119 (Bilbo, 1998) was granted for a portable suction unit. This device is design for removal of mucus, sputum, and bodily fluids.

Looking at the current state of the art research, development of portable suction devices is a well-developed area, the problem lies in the fact that there is still a significant gap in the implementation of technology to assist emergency responders to help save lives.

General Information and Device Usability

For the purposes of illustration of the current state-of-the-art in commercial portable suction devices, the Laerdal Compact Suction Unit® 4 (LCSU® 4) is described. This device is intended to maintain a person's airway through the use of medical vacuum or suction. The versatile design shown in Figure 3 displays a 300 mL and 800 mL reservoir configuration. Depending on the emergency, the pump and electronics housing can be attached to the desired fluid storage capacity container. Both containers are disposable and enclose a hydrophobic filter which prevents any unwanted fluids from entering the main housing.



Figure: LCSU 4

Pressure display and Suction Adjustment

By adjusting the dial, the device provides a variable flow rate/suction feature. Suction can be varied from 50 to 550 mmHg, in 50 mmHg increments.

Performance

Pump

A maximum flow rate of 30 LPM (liters per minute of air) can be provide by the pump under no load. The maximum vacuum the pump can provide is 550 mmHg, although the flow rate at this stage was not specified.

Power Consumption and Display

This device displays significantly low efficiency in power consumption. Specifications state that the device can run for 45 minutes under no load (free flow). Therefore, the run time under maximum vacuum should be relatively low (not specified). Battery consumption is displayed in a control panel which provides low battery alert, external power indicator and fully charged alert features.

Specification Comparison

The following table was developed based on the specifications that were used to develop the design concept.* Unless otherwise specified, specifications stated for the Laerdal Compact Suction Device were obtained from the Laerdal website www.Laerdal.com.

Table 1: Specification Comparison

Specification	Concept Design Suction Device	Laerdal Compact Suction Device
Pump Flow Rate	3 L/min (vomitus)	30 Liters/ Minute (air flow)
Suction Performance	Vacuum Range: 0-550 mmHg	Vacuum Range: 50 -550 mmHg
Weight	< 1kg (2.2 lbs)	@ 300 mL configuration, 3.3 lbs. @500 mL configuration,4.3 lbs.
Hose Diameter	5/8 in diameter tubing.	3/16 in diameter tubing.
Noise Level	≤ 70 dB.	≤ 70 dB
Fluid Storage	1000 mL.	300 mL and 500 mL configurations available
Power	12V rechargeable power source.	12V rechargeable power source.
Control	Device allows for adjustment of flow rate/ suction through the use of a dial.	Device allows for adjustment of flow rate/ suction through the use of a dial.
Foot Print	30 x 10 x 10 cm	@ 300 mL, 7.3" x 10.3" x 3.2" @ 500 mL, 9.3" x 7.5" x 9.3"
Pressure display	None	Provides pressure values

*[For a detailed review of specifications and design considerations, readers are referred to A Report on Deliverable Four: Develop a Specifications List for a Portable, Lightweight Prehospital Suction Device. Contract Number: W81XWH-17-P-0022 Support the (TCCCR) Task Area for Research and Development of Medical Equipment to Clear and Maintain a Combat Airway. Report Author: Robert A. De Lorenzo, MD, MSCI, MSM, FACEP, Department of Emergency Medicine, UT Health San Antonio, September 4, 2017.]

Cost and Current Use

The listed price for the 300 mL and 800 mL is \$553 and \$675 respectively as of 2017. This includes the single body (pump & electronics housing), reservoir, filter and a standardized suction line. The canister (fluid storage) and tubing are listed at \$14.45 and \$28.90 for the 300 mL and 800 mL respectively. It was found that LCSU® 4 is currently in use by fire departments in North America. The Laerdal Co. possesses distribution cells in 23 countries around the world, concentrating most resources and personnel in North America.

Prior Art Conclusion

Based on the analyzed information, it was determined that the LCSU® 4 represents the typical unit used in the commercial prehospital care environment. This medical device is a reasonable benchmark for further design development.

Relevant ISO Standard (ISO 10079-1)

ISO 10079-1 is a standard specifically for electrically powered suction equipment for hospital and emergency care use. It specifies minimum safety and performance requirements for medical and surgical suction equipment for healthcare facilities such as hospitals, for domiciliary care of patients and for field and transport use. It is recommended that you review this standard for guidance in the development of this device.

Pump Performance and Suction Rate

The pump suction shall comply with ISO 10079-1 in that the suction equipment shall develop a vacuum of at least 40kPa below atmospheric pressure within 10 seconds.

Weight

In accordance with ISO 10079-1 the mass of the handheld suction device shall not exceed six kilograms.

Hose Assembly

In accordance with ISO 10079-1, the tubing diameter must be a minimum of 6 millimeters.

Noise Level

In accordance with ISO 10079-1, the acoustic energy cannot exceed 80 dbA for a cumulative exposure of 24 hours. A peak level of 140 dbC for acoustic noise is the maximum value for non-exposure values. The testing of the medical equipment is to be operated under its "worst case" normal condition. The test room is to be semi-reverberant with a hard reflecting floor and the distance between any wall or object and surface is not be less than 3 meters. In accordance with ISO 10079-1, the vibration of the device should not exceed 2.5 m/s^2 over a time interval of 8 hours.

Power Supply

According to ISO 10079-1, the power supply shall not exceed 250 V for a handheld device. The frequency must be less than or equal to 1 kHz.

Display and Indicators

In accordance with 10079-1, the vacuum indicator for analog displays shall have graduations not less than 2 mm apart. For digital displays, the medical device shall display vacuum at intervals of not greater than 2 % of the full-scale value. The maximum vacuum for which the equipment is designed shall be marked prominently on the display case or immediately adjacent to it.

Operation and Storage Conditions

In accordance with ISO 10079-1, the device shall be operable in a temperature range of -18 to $50 (\pm 2) ^\circ\text{C}$. In addition, the device shall also be capable of being stored in temperatures ranging from -40 to $60 (\pm 2) ^\circ\text{C}$.

Suction Rate

The suction device shall remove 200 mL of vomitus solution in less than 10 seconds (Section 59.9)

Summary and Conclusions

Suction is a critical component of airway management, which is the second leading cause of preventable battlefield death. Current commercially available portable suction devices can serve as design benchmarks for current state-of-the-art performance. A concept design for a future device is described and key design and engineering aspects are reviewed.

Acknowledgements

The author wishes to acknowledge the administrative and editorial skill, tireless effort and patience of Heather Wantuch, MPA; and the technical advice, support and background information of Bruce Adams, MD, Steve Yeadon, and Lyle Hood, PhD.

Appendix A - Key Task of the Report

Develop a concept design for a ruggedized, lightweight, portable, powered handheld suction device that is capable of quickly and fully clearing fluid and debris from the airway of a combat casualty. The concept should meet the following fundamental requirements: 1) Portable, 2) Lightweight, 3) Battery Powered, 4) Easily decontaminated from body fluids, 5) operable in anticipated environmental conditions (per Mil Std), and 6) be certifiable airworthy (per Mil Std). Deliverables will be: A report of a design concept including basic design specifications, appropriate sketches, identification of key parts and costs, and discussion of existing patent issues that affect the design.

Appendix B - Technical Approach

Existing and projected (future) military medical requirements relevant to the expected combat and operational scenarios (such as prolonged field care) are identified. The required performance characteristics of a suction unit intended for prehospital combat casualty care is ascertained based on these anticipated operational scenarios. The key characteristics searched include vacuum suction flow rate, pressure, and capacity to evacuate the expected fluid/particle viscosity/size (e.g., saliva, blood, vomitus, mud, gravel, broken teeth) for management of prehospital Combat Casualty Care injuries. Source documents were extracted from 1980-present and analyzed for title content. If relevant, the article was reviewed in detail. Secondary references prior to 1980 were selectively searched based on the title and the likelihood of topical relevance. Specific sources searched include but are not limited to:

- Committee on Combat Casualty Care (CoTCCC)
- Medical literature using Medline or equivalent with search terms including
 - *Suction*
 - *Vacuum*
 - *Aspiration*
 - *Airway, airway management*
 - *Airway obstruction*
 - Modifier terms including *safety, efficacy, and performance*
- Engineering literature using Academic Search (EBSCO), or equivalent using similar search terms as above
- Defense Technical Information Center (DTIC)
- Retrievable information from conferences and meetings focused on combat casualty care, prehospital care, and airway management.
- Government standards including FDA
- Industry and government standards clearinghouses including ISO

Where necessary to fill in information gaps, existing requirements were supplemented with proposed requirements vetted against local expert military and civilian medical consultations. UT Health San Antonio maintains a robust panel of US military experts in emergency medicine and prehospital care that can be consulted. Additionally, UT Health San Antonio is in close proximity to and maintains a healthy relationship with

JBSA-Fort Sam Houston which is the US military's key hub of combat casualty care and trauma training, and UT Health San Antonio retains the ability to consult with the organizations and personnel within this installation as well as other US military installations worldwide.

The available information is organized, critically appraised, and synthesized into a narrative report that summarizes the performance characteristics for management of prehospital combat

Appendix C – Concept Design Schematic Drawing

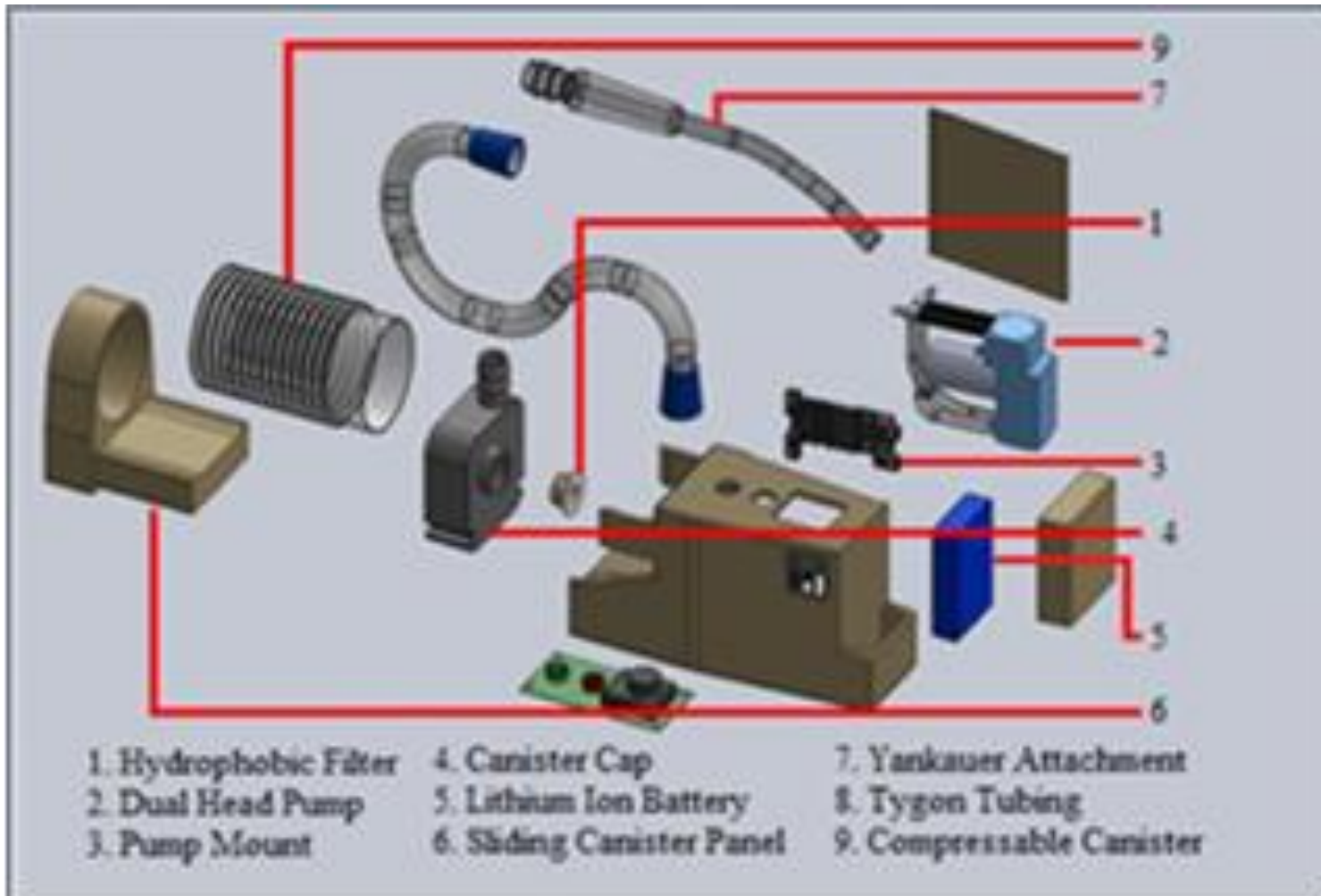

Appendix D – Parts List

Legend	Company	Miscellaneous parts		Description	Quantity	Price/ part	Total Price	Web link
		Item No.	Part Number					
	Amazon	1	N/A	Soldering Station: X-Tronic Model #3020-XTS Digital LED Display	1	\$ 49.80	\$ 49.80	https://www
	Sparkfun	2	N/A	SE MZ1018 Helping Hand with Magnifying Glass	2	\$ 6.26	\$ 12.52	https://www
	Adafruit	3	N/A	luxcell® 900M-T-LI 0.8mm Point Diameter Soldering Solder Iron Tips 5 Pcs	3	\$ 4.31	\$ 12.93	https://www
	Mouser Electronics	4	N/A	Rosin Paste Flux #135 in a 2 oz jar	1	\$ 10.11	\$ 10.11	https://www
	McMaster Carr	5	N/A	Synwax 1.0mm 10g Lead Free Solder Wire Tin Reel with Rosin Core Sn 99% Ag 0.3% Cu 0.7%	1	\$ 25.99	\$ 25.99	https://www
		6	N/A	Fluke 179/TPAK True RMS Digital Multimeter with TPAK Meter Hanging Kit, 50 Megohm Resistance, 1000V AC/DC Voltage, 10A AC/DC Current	1	\$ 404.50	\$ 404.50	https://www
		7	N/A	Feedback Sports Table Top Digital Gram Scale (Red, 3-Kilogram)	1	\$ 45.58	\$ 45.58	https://www
		8	N/A	Lock&Lock 4L 6-Cup 338-Fluid Ounce Rectangular Container with Handle and Tray, Tall	2	\$ 41.00	\$ 82.00	https://www
		9	N/A	Elenco 350 Piece Pre-formed Jumper Wire Kit	2	\$ 14.49	\$ 28.98	https://www
		10	N/A	Remington Industries 20UL10075TRKIT UL1007 20 AWG Gauge Stranded Hook-Up Wire Kit, 300V, 0.0320" Diameter, 25', 3" Length	1	\$ 26.31	\$ 26.31	https://www
		11	N/A	Remington Industries 22UL10075TRKIT UL1007 22 AWG Gauge Stranded Hook-Up Wire Kit, 300V, 0.0253" Diameter, 25', 3" Length	1	\$ 20.61	\$ 20.61	https://www
		12	N/A	PanaVise Model 201 "Junior" Miniature Vise	1	\$ 26.99	\$ 26.99	https://www
		13	N/A	CRIMPING PLIERS 10" by IRWIN MfP Part No 2078310	1	\$ 18.71	\$ 18.77	https://www
		14	N/A	IRWIN VISE-GRIP Multi-Tool Wire Stripper/Crimper/Cutter, 2078309	1	\$ 15.58	\$ 15.58	https://www
		15	N/A	URBEST™ 530 Pcs 2:1 Heat Shrink Tubing Tube Sleeving Wrap Cable Wire 5 Color 8 Size	1	\$ 10.29	\$ 10.29	https://www
		16	N/A	Darius 480 Pcs Premium Quality Assorted Insulated Electrical Wire Terminals Crimp Connectors Spade Set	1	\$ 23.00	\$ 23.00	https://www
		17	N/A	Hakko CHP-170 Micro Soft Wire Cutter, 1.5mm Stand-off, Flush Cut, 2.5mm Hardened Carbon Steel Construction, 21-Degree Angled Jaw, 8mm Jaw Length, 16 Gauge Maximum Cutting Capacity	1	\$ 5.99	\$ 5.99	https://www
		18	N/A	Kuman 120pcs Breadboard Jumper Wires For Arduino Raspberry Pi 40pin Male to Female, 40pin Female to Female Ribbon Cables Kit Multicolored Pack K45	1	\$ 9.99	\$ 9.99	https://www
		19	N/A	CO ROIDE 300pcs 3mm 5mm Assorted Color 2pin Diffused LED Light Emitting Diodes Electronic Parts with 5 Colors	1	\$ 14.99	\$ 14.99	https://www
		20	N/A	E-Projects EPC-103 16 Value Resistor Kit, 10 Ohm - 1M Ohm (Pack of 400)	1	\$ 11.33	\$ 11.33	https://www
		21	N/A	100 pcs Rectifier Diode Tape kit_IN4148 1N4007 1N5819 1N5359 FR107 FR207 1N5408 1N5822	1	\$ 2.71	\$ 2.71	https://www
		22	N/A	Sunkee S9012 S9013 S9014 A1015 C1815 S8050 S8550 2N3904 2N3906 A42 A92 A733,17valuesx10pcs=170pcs, Transistor Assorted Kit	1	\$ 9.99	\$ 9.99	https://www
		23	N/A	10 pcs UA741 LM741 17741 IC OP AMP COMPENSATED DIP-8	1	\$ 6.58	\$ 6.58	https://www
		24	N/A	luxcell 60 Pcs 8 Pin 2.54mm Pitch DIP IC Sockets Adaptor	1	\$ 3.34	\$ 3.34	https://www
		25	N/A	50 Pcs 5mm Round Head Common Cathode RGB Light LED Emitting Diodes	1	\$ 2.56	\$ 2.56	https://www
		26	N/A	Leather /Vinyl Restorers (ORGANIZER, PORTABLE, 15X11X3IN) 1 Each / Each	1	\$ 53.95	\$ 53.95	https://www
		27	N/A	VISHAY SERVICIS P18W102KAD15 POTENTIOMETER CERMET, 10KOHM 10% 1W	2	\$ 17.00	\$ 34.00	https://www
		28	N/A	Enegizer Ultimate Lithium Battery, 2 Count	4	\$ 12.97	\$ 51.88	https://www
		29	N/A	3pcs Replacement Double Wire Lead 9V Battery Box Case Holder Connector	3	\$ 6.60	\$ 19.80	https://www
		30	N/A	luxcell® 10 Pcs Faux Leather Housing T Type Clip Connector for 9V Battery	1	\$ 4.04	\$ 4.04	https://www
		31	N/A	DIYmall SA 75W DC-DC Adjustable Step-down Module with Voltmeter	2	\$ 7.99	\$ 15.98	https://www
		32	N/A	Lavolta BP5305 Variable Linear DC Power Supply 0 - 30V / 0 - 5A - Regulated Adjustable Lab Kit with Alligator Leads	1	\$ 76.49	\$ 76.49	https://www
		33	N/A	Elenco TL-12 Banana to Mingrabber Set	1	\$ 6.79	\$ 6.79	https://www
		34	N/A	Elenco Banana to Banana Test Lead Set	1	\$ 6.46	\$ 6.46	https://www
		35	N/A	Elenco Electronics TL-16 Banana to Large Alligator Test Lead Set	1	\$ 6.99	\$ 6.99	https://www
		36	PRT-00112	Breadboard - Classic	1	\$ 9.95	\$ 9.95	https://www
		37	PRT-12614	Breadboard - Giant	1	\$ 19.95	\$ 19.95	https://www
		38	PRODUCT ID: 321	Large Alligator Clip Test Lead (set of 10)	1	\$ 4.95	\$ 4.95	https://www
		39	PRODUCT ID: 1008	Small Alligator Clip Test Lead (set of 12)	1	\$ 3.95	\$ 3.95	https://www
		40	PRODUCT ID: 1359	SMD Component Testing Tweezers	1	\$ 27.95	\$ 27.95	https://www
		41	PRODUCT ID: 1597	Professional Silicone-Tip Solder Sucker	1	\$ 17.50	\$ 17.50	https://www
		42	PRODUCT ID: 422	Fine tip curved tweezers - ESD safe - 120mm	1	\$ 3.95	\$ 3.95	https://www
		43	PRODUCT ID: 807	Dual H-Bridge Motor Driver for DC or Steppers - 600mA - L293D	3	\$ 2.95	\$ 8.85	https://www
		44	PRODUCT ID: 2203	IC Socket - for 16-pin 0.3" Chips - Pack of 3	1	\$ 0.95	\$ 0.95	https://www
		45	PRODUCT ID: 421	Fine tip straight tweezers - ESD safe - 135mm	1	\$ 3.95	\$ 3.95	https://www
		46	PRODUCT ID: 723	Adafruit Perma-Proto Mint Tin Size Breadboard PCB	2	\$ 5.95	\$ 11.90	https://www
		47	PRODUCT ID: 591	Adafruit Perma-Proto Super Pack!	1	\$ 34.95	\$ 34.95	https://www
		48	PRODUCT ID: 1214	Adafruit Perma-Proto Small Mint Tin Size Breadboard PCB - 3 pack	1	\$ 7.95	\$ 7.95	https://www
		49	P1-CMF5029K300FHEB	Metal Film Resistors - Through Hole 1/4W 38.3kohms 2%	10	\$ 0.46	\$ 4.60	https://www
		50	576-0313002 HXP	Littelfuse	4	\$ 1.02	\$ 4.08	http://www
		51	11355184	Durable Nylon Extra-Grip Barbed Tube Fitting, Straight for 1/2" Tube ID x 3/8 Male Pipe Size, packs of 10	1	\$ 4.76	\$ 4.76	http://www
		52	5372K118	Durable Nylon Extra-Grip Barbed Tube Fitting Straight for 3/8" Tube ID x 3/8 Male Pipe Size	1	\$ 4.71	\$ 4.71	http://www
		53	5372K123	Durable Nylon Extra-Grip Barbed Tube Fitting Straight for 1/2" Tube ID x 1/4 Male Pipe Size	1	\$ 4.73	\$ 4.73	http://www
		54	5372K117	Durable Nylon Extra-Grip Barbed Tube Fitting Straight for 3/8" Tube ID x 1/4 Male Pipe Size	1	\$ 4.54	\$ 4.54	http://www
		55	5195178	Abrasion-Resistant Polyurethane Tubing for Water, 1/2" ID, 3/4" OD, 25 Ft	1	\$ 76.25	\$ 76.25	http://www
		56	5195182	Abrasion-Resistant Polyurethane Tubing for Water, 3/4" ID, 1" OD, 10 Ft	1	\$ 30.70	\$ 30.70	http://www
		57	53055K145	Sanitary White PVDF Barbed Tube Fitting Reducing Straight for 3/4" x 1/2" Tube ID	1	\$ 4.19	\$ 4.19	http://www