



February 5, 2018

Defense Technical Information Center  
8725 John J Kingman Road Ste 0944  
Fort Belvoir, VA 22060-6218

**HOLCOMBE DEPARTMENT OF  
ELECTRICAL & COMPUTER  
ENGINEERING**

Clemson University  
105 Riggs Hall  
Box 340915  
Clemson, SC  
29634-0915

P 864-656-5650  
F 864-656-5917

[www.clemson.edu/cecas/ece](http://www.clemson.edu/cecas/ece)

Dear Defense Technical Information Center:

Please find enclosed the Final Technical Report with accompanying SF298 for Office of Naval Research award N00014-16-1-3113.

Very respectfully,

Daniel L. Noneaker, Department Chair  
Holcombe Department of Electrical and Computer Engineering  
105 Riggs Hall, Clemson SC 29634-0915  
Em: [dnoneak@clemson.edu](mailto:dnoneak@clemson.edu)  
Ph: 864-656-0100, Fax: 864-656-5917

**REPORT DOCUMENTATION PAGE**

Form Approved  
OMB No. 0704-0188

The public reporting burden for this collection of information is estimated to average 1 hour per response, including the time for reviewing instructions, searching existing data sources, gathering and maintaining the data needed, and completing and reviewing the collection of information. Send comments regarding this burden estimate or any other aspect of this collection of information, including suggestions for reducing the burden, to Department of Defense, Washington Headquarters Services, Directorate for Information Operations and Reports (0704-0188), 1215 Jefferson Davis Highway, Suite 1204, Arlington, VA 22202-4302. Respondents should be aware that notwithstanding any other provision of law, no person shall be subject to any penalty for failing to comply with a collection of information if it does not display a currently valid OMB control number.  
**PLEASE DO NOT RETURN YOUR FORM TO THE ABOVE ADDRESS.**

1. REPORT DATE (DD-MM-YYYY) 31-12-2017		2. REPORT TYPE Final Technical Report		3. DATES COVERED (From - To) 01-09-2016 -- 31-12-2017	
4. TITLE AND SUBTITLE Addressing Circuitous Currents MVDC Power Systems Protection				5a. CONTRACT NUMBER	
				5b. GRANT NUMBER N00014-16-1-3113	
				5c. PROGRAM ELEMENT NUMBER	
6. AUTHOR(S) Noneaker, Daniel L. Corzine, Keith Maqsood, Atif				5d. PROJECT NUMBER	
				5e. TASK NUMBER	
				5f. WORK UNIT NUMBER	
7. PERFORMING ORGANIZATION NAME(S) AND ADDRESS(ES) Clemson University 201 Sikes Hall Clemson, SC 29634-0001 USA				8. PERFORMING ORGANIZATION REPORT NUMBER N00014-16-1-3113_Final_Technical_Report	
9. SPONSORING/MONITORING AGENCY NAME(S) AND ADDRESS(ES) Office of Naval Research 875 N. Randolph Street, Suite 1425 Arlington, VA 22203-1995				10. SPONSOR/MONITOR'S ACRONYM(S) ONR	
				11. SPONSOR/MONITOR'S REPORT NUMBER(S)	
12. DISTRIBUTION/AVAILABILITY STATEMENT Approved for public release: distribution is unlimited					
13. SUPPLEMENTARY NOTES					
14. ABSTRACT The work investigates Z-source breakers in multi-zone systems with current to the load through multiple paths. The zonal distribution planned for future navy ships is emulated. Detailed simulations and development of a low voltage DC testbed are documented. DC zonal distribution can increase the power density on Navy ships, so that future ships achieve reduced weight and volume and higher efficiency. A challenge with DC distribution is electrical protection. Z-source DC breakers are an option being considered and this work explores the integration of these breakers into DC zonal distribution systems.					
15. SUBJECT TERMS Z-source breakers, multi-zone power distribution, DC zonal distribution, electric ship					
16. SECURITY CLASSIFICATION OF:			17. LIMITATION OF ABSTRACT	18. NUMBER OF PAGES	19a. NAME OF RESPONSIBLE PERSON
a. REPORT	b. ABSTRACT	c. THIS PAGE			Daniel L. Noneaker
U	U	U	UU	24	19b. TELEPHONE NUMBER (Include area code) (864)656-0100

## INSTRUCTIONS FOR COMPLETING SF 298

**1. REPORT DATE.** Full publication date, including day, month, if available. Must cite at least the year and be Year 2000 compliant, e.g. 30-06-1998; xx-06-1998; xx-xx-1998.

**2. REPORT TYPE.** State the type of report, such as final, technical, interim, memorandum, master's thesis, progress, quarterly, research, special, group study, etc.

**3. DATE COVERED.** Indicate the time during which the work was performed and the report was written, e.g., Jun 1997 - Jun 1998; 1-10 Jun 1996; May - Nov 1998; Nov 1998.

**4. TITLE.** Enter title and subtitle with volume number and part number, if applicable. On classified documents, enter the title classification in parentheses.

**5a. CONTRACT NUMBER.** Enter all contract numbers as they appear in the report, e.g. F33315-86-C-5169.

**5b. GRANT NUMBER.** Enter all grant numbers as they appear in the report. e.g. AFOSR-82-1234.

**5c. PROGRAM ELEMENT NUMBER.** Enter all program element numbers as they appear in the report, e.g. 61101A.

**5e. TASK NUMBER.** Enter all task numbers as they appear in the report, e.g. 05; RF0330201; T4112.

**5f. WORK UNIT NUMBER.** Enter all work unit numbers as they appear in the report, e.g. 001; AFAPL30480105.

**6. AUTHOR(S).** Enter name(s) of person(s) responsible for writing the report, performing the research, or credited with the content of the report. The form of entry is the last name, first name, middle initial, and additional qualifiers separated by commas, e.g. Smith, Richard, J, Jr.

**7. PERFORMING ORGANIZATION NAME(S) AND ADDRESS(ES).** Self-explanatory.

**8. PERFORMING ORGANIZATION REPORT NUMBER.** Enter all unique alphanumeric report numbers assigned by the performing organization, e.g. BRL-1234; AFWL-TR-85-4017-Vol-21-PT-2.

**9. SPONSORING/MONITORING AGENCY NAME(S) AND ADDRESS(ES).** Enter the name and address of the organization(s) financially responsible for and monitoring the work.

**10. SPONSOR/MONITOR'S ACRONYM(S).** Enter, if available, e.g. BRL, ARDEC, NADC.

**11. SPONSOR/MONITOR'S REPORT NUMBER(S).** Enter report number as assigned by the sponsoring/monitoring agency, if available, e.g. BRL-TR-829; -215.

**12. DISTRIBUTION/AVAILABILITY STATEMENT.** Use agency-mandated availability statements to indicate the public availability or distribution limitations of the report. If additional limitations/ restrictions or special markings are indicated, follow agency authorization procedures, e.g. RD/FRD, PROPIN, ITAR, etc. Include copyright information.

**13. SUPPLEMENTARY NOTES.** Enter information not included elsewhere such as: prepared in cooperation with; translation of; report supersedes; old edition number, etc.

**14. ABSTRACT.** A brief (approximately 200 words) factual summary of the most significant information.

**15. SUBJECT TERMS.** Key words or phrases identifying major concepts in the report.

**16. SECURITY CLASSIFICATION.** Enter security classification in accordance with security classification regulations, e.g. U, C, S, etc. If this form contains classified information, stamp classification level on the top and bottom of this page.

**17. LIMITATION OF ABSTRACT.** This block must be completed to assign a distribution limitation to the abstract. Enter UJU (Unclassified Unlimited) or SAR (Same as Report). An entry in this block is necessary if the abstract is to be limited.

# **Addressing Circuitous Currents MVDC Power System Protection**

Final Report  
Contract N00014-16-1-3113

Dr Dan Noneaker  
Department of Electrical and Computer Engineering  
Clemson University, Clemson SC

Dr. Keith Corzine  
Atif Maqsood  
Department of Electrical Engineering  
University of California Santa Cruz, CA

31 December 2017

## Contents

Research Motivation	3
Task 1: Zonal System Development	3
Task 2: Breaker Reconfiguration Control	17
Conclusion	24

## Research Motivation

This work investigates the application of Z-source breaker in multi-zone systems where current is provided to the load through multiple paths. This study is meant to emulate the zonal distribution system planned for future navy ships. Results from detailed simulation as well as development of a low-voltage dc testbed are documented in this report. The motivation behind using dc zonal distribution is to increase the power density on Navy ships. That allows future navy ships to meet their goal of reducing weight and volume; hence meeting higher efficiency standards. The future Naval designs will be more compact as a result of this development. A challenge with dc distribution is electrical protection. Z-source dc breakers are one of the options being considered and this work explores the integration of these breakers into dc zonal distribution systems.

### Task 1: Zonal System Development

Task 1 specifically states "A detailed simulation will be created specifically to study the problem of circuitous currents in a zonal ship power system. It will consist of port and starboard busses feeding two zones through a set of four power converters and four z-source breakers. Faults will be simulated at various points in the system to determine the effect on system operation. A small scale laboratory system corresponding to the simulation will be setup."

For this task the system being studied is shown in Figure 1. There are two different scenarios being considered. The case in Figure 1a) is two-converter four-breaker system wherein two converters are sharing the load to feed two zones. The case in Figure 1b) is four-converter four-breaker system where each load zone has its own independent set of port and starboard converters. Figure 1 shows the system with zones numbered 1 to  $n$ . For the detailed simulation only two of the zones are considered to highlight the problem of circuitous currents. The rest of the system is an extension of those two zones. A screenshot of the system simulation on PSCAD is shown in Figure 2 for case in Figure 1b).

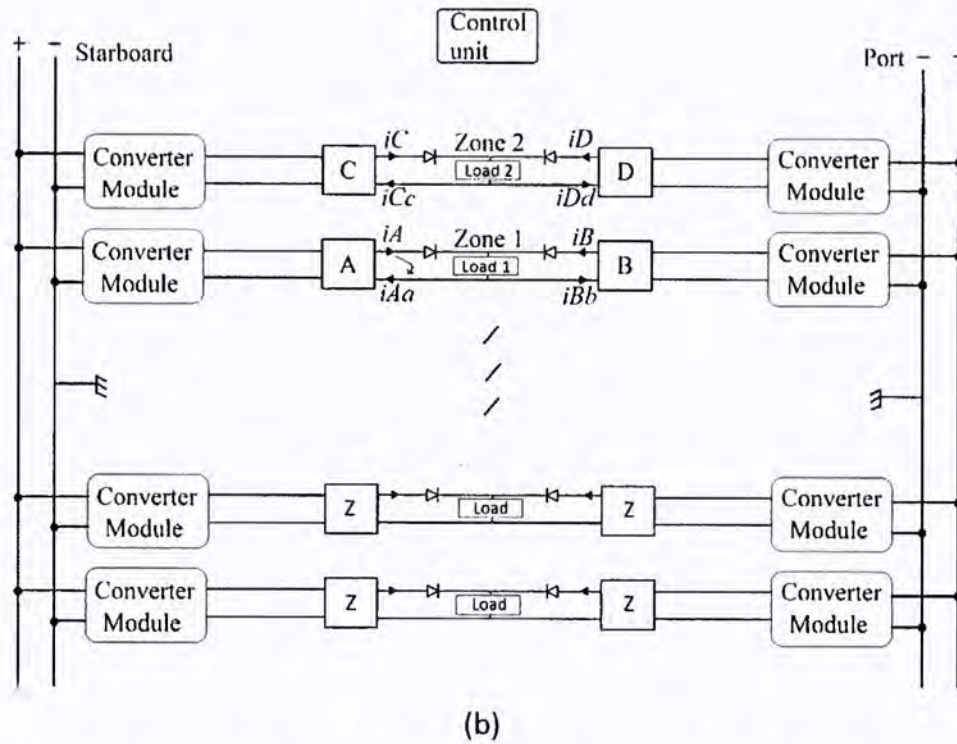
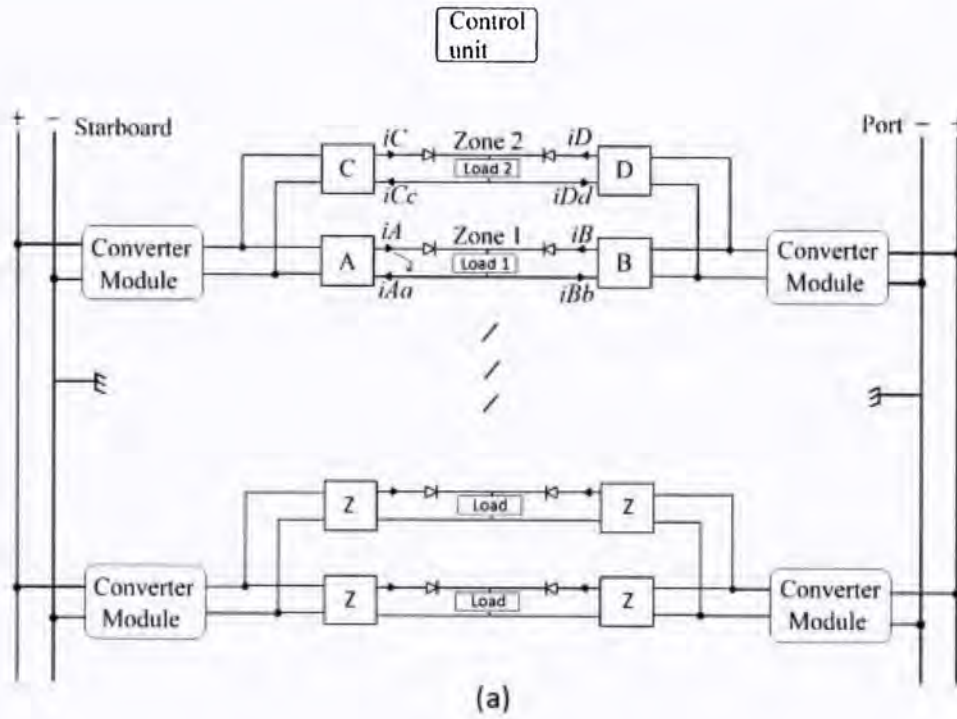

Figure 1. Zonal dc power system (a) two-converter four-breaker system  
 (b) four-converter four-breaker system.



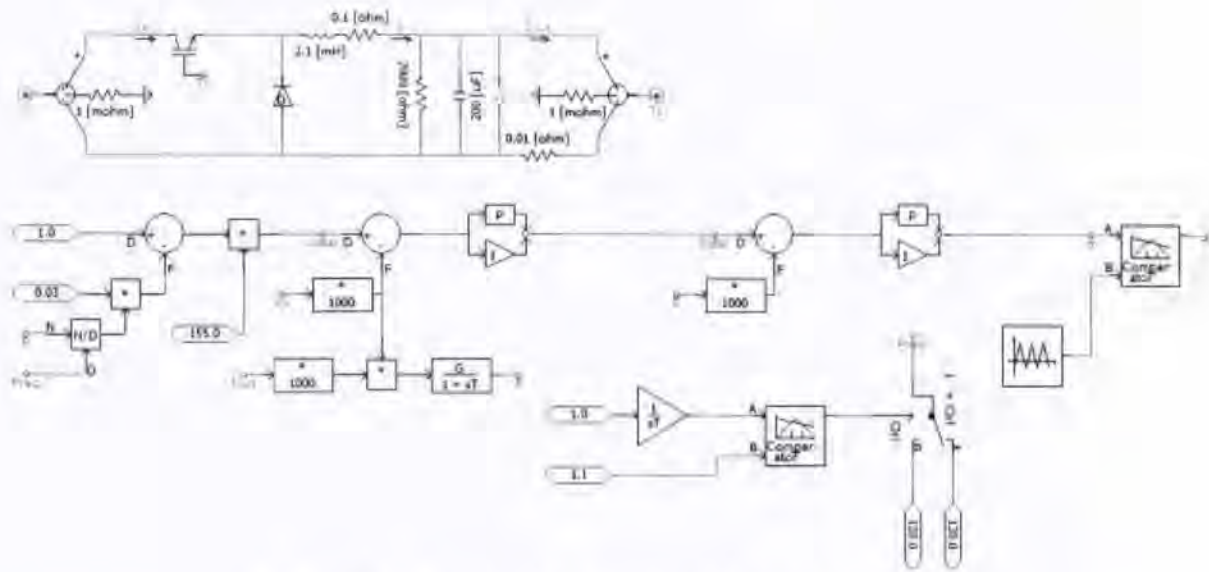

Figure 3. Screenshot of a converter module simulation.

The control of the converter requires feedback from converter's output current, inductor current and output voltage. Another control input is the required power from the converter which is provided by a central control and may change depending on the configuration and power sharing formula of the system. The output power of the converter is calculated as the product of measured output voltage and measured output current. This power is compared to the required power perimeter and adjusted with a 3% droop to calculate the required output voltage. The required output voltage is compared to the actual measured output voltage to adjust the required inductor current through PI control. This required inductor current is compared to the measured inductor current to adjust the required duty cycle of IGBT gate PWM signal through another PI control loop. The values of PI loop gains are selected by trial and error for the smoothest current and voltage transitions.

The breaker design selected for this project is the cross-connected Z-source breaker with an additional snubber branch and resistive current limiting. A screenshot of the breaker module is shown in Figure 4. During steady-state operation the capacitors charge up to the input dc voltage and the inductors carry all the current. The SCR is given a pulse at its gate which allows it to conduct current and then the gate pulse is removed so the breaker is ready to respond to a fault. When there is a sharp change of resistance across the output of the breaker, the capacitors begin



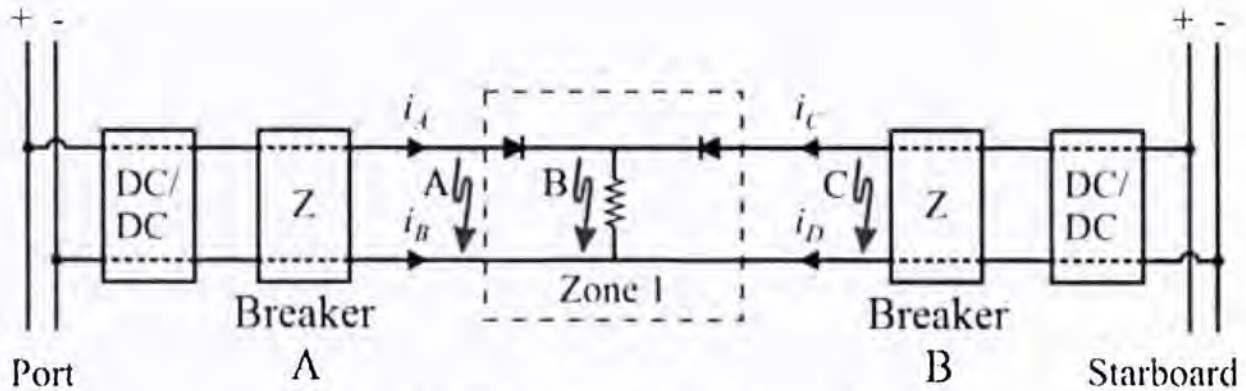

Figure 5. Fault locations studied for each zone.

A fault at location B is directly across the load and so the entire zone must be isolated from the system. This would mean the breakers at port and starboard both should open. The result from this simulation of a single zone is shown in Figure 6. The top two subplots are the input and output currents respectively of breaker A. The next two subplots are the input and output currents of breaker B and the bottom subplot is the fault current. It can be seen that the output currents of breaker A and breaker B contribute equally to the fault current and input current of these breakers show how quickly the system isolates the zone from the port and starboard bus.

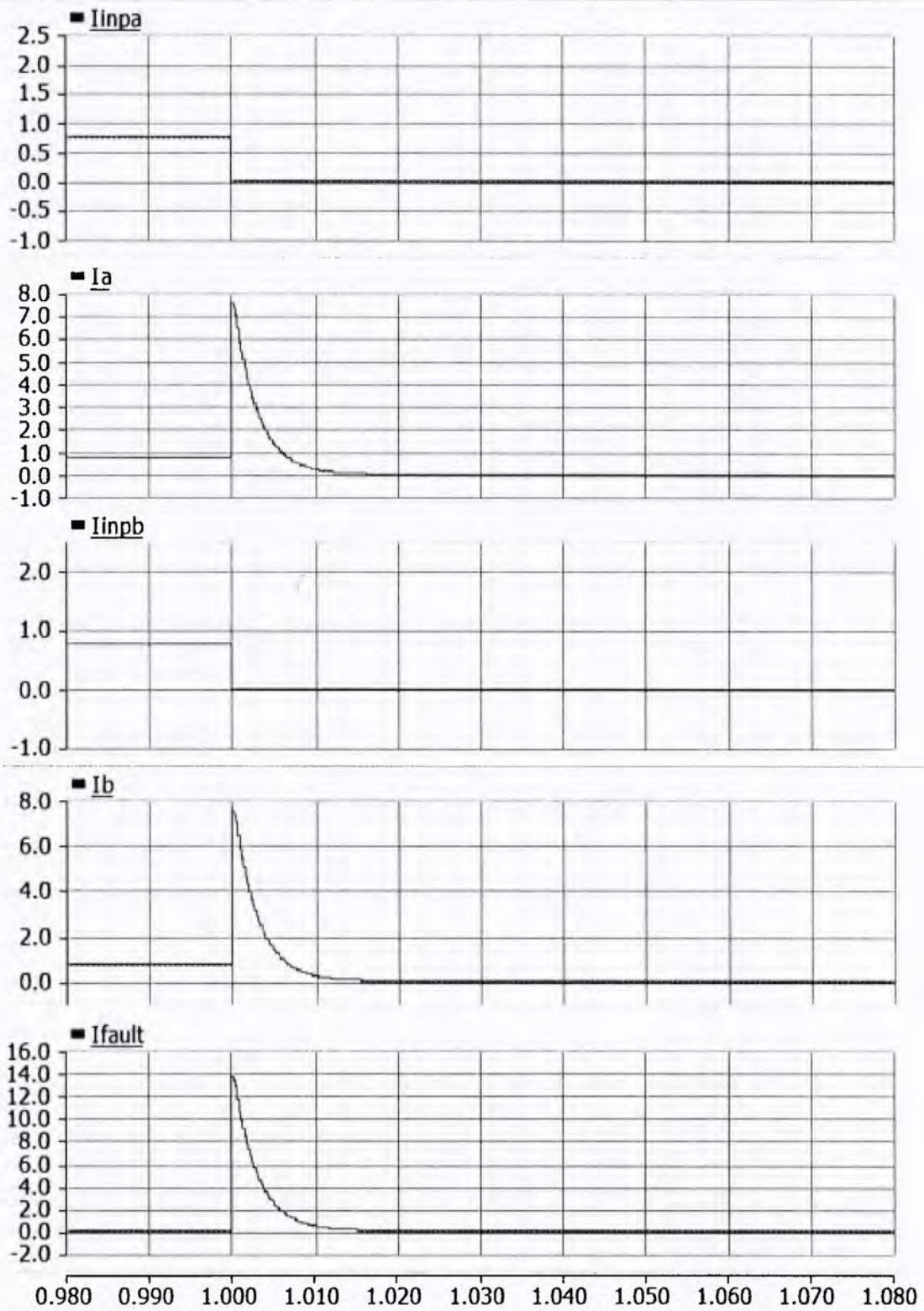

Figure 6. System response for a fault at location B.

The presence of auctioneering diodes in these zones ensures that the load can be fed from either port or starboard side if required. It is possible to open one of the breakers and have twice the power flow from the other one. This also allows the flexibility in case of a fault at position A or C as shown in Figure 5 that the load can continue to get power through one of the sides at least. However, when the case is simulated with fault at location A it is observed that both the breakers still open which is not the ideal result. Figure 7 shows the current waveforms same as Figure 6 but for the case of fault at location A. From figure 7 it can be seen that both the breakers open although there is no sharp spike of current at the output of Breaker B and output of breaker A provides bulk of the fault current.

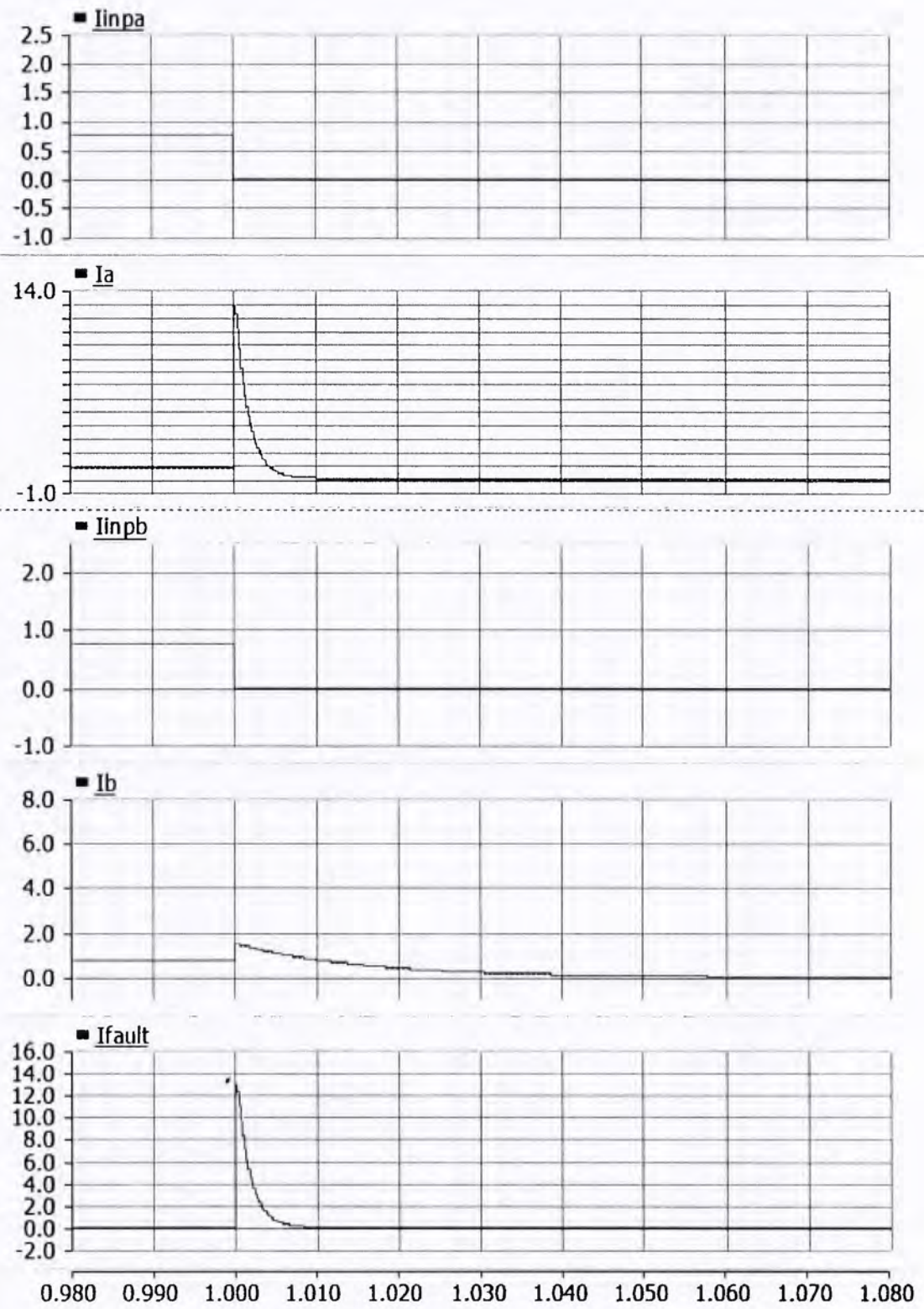

Figure 7. System response for a fault at location A.

For the system shown in Figure 1, neither the Z-source breakers nor the dc/dc converters provide galvanic isolation. This means that there is an electric path from the negative rail of starboard bus to the negative rail of the port bus. This could lead to circuitous current in the system in the case of transients such as a shunt fault. For the fault location A, the path of circuitous fault current is traced and shown in Figure 8. The source of this current is the capacitor at the output of the buck converter on the port side of system. The capacitor at the output of buck converter on the starboard side does not see the fault due to blocking diodes. The discharge path of the capacitor creating this circuitous current includes the inductors of Z-source breakers.

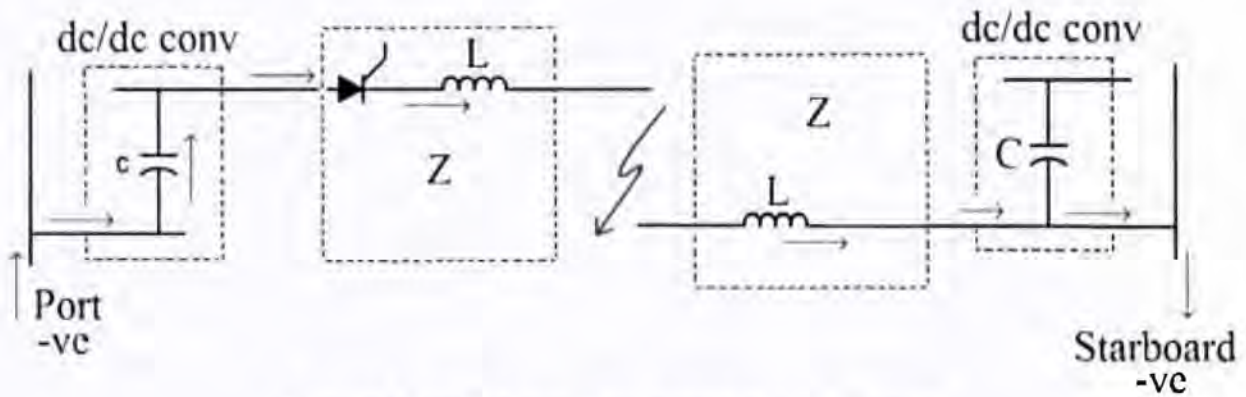

Figure 8. Path of circuitous current in a single zone.

The initial injection of this circuitous current in the negative rail of starboard side Z-source causes the SCR in its positive rail to be reversed biased and the current through it falls to zero instantly. One way to prevent this from happening is to block this current path using a diode. Another diode should be added to block the path of circuitous current in case the fault occurs at the starboard side. The resulting system with two additional diodes is shown in Figure 9. The diode labeled X will block the circuitous current without blocking the current for normal operation.

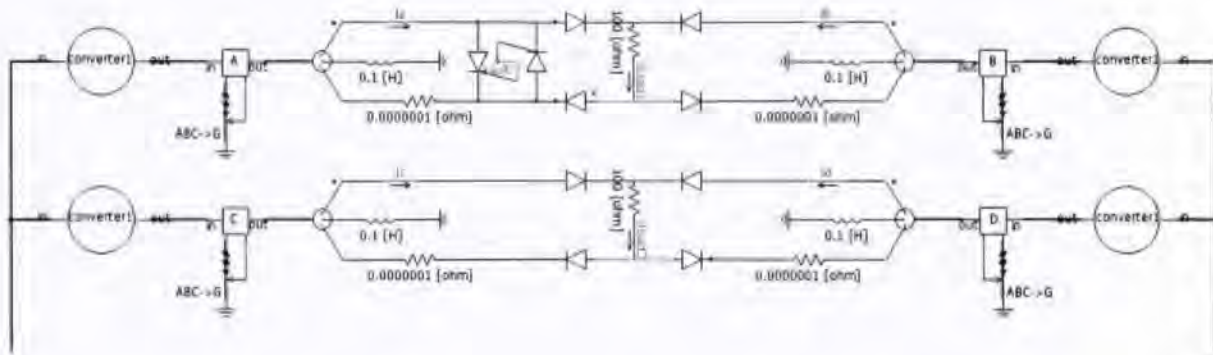

Figure 9. Simulated system with additional negative rail diode.

The system in Figure 9 is simulated for the fault location shown. Only the breaker at the port side opens. The resulting current waveforms are shown in Figure 10 in the same order as in Figures 6 and 7. It can be seen that there is no large spike in current for output of breaker B. This means that the injection of capacitive discharge from the port-side converter to the starboard-side breaker has been blocked. As a result, the starboard-side breaker is prevented from opening. It can be seen that after the fault, the current through breaker B doubles to compensate for loss of power from the port side.

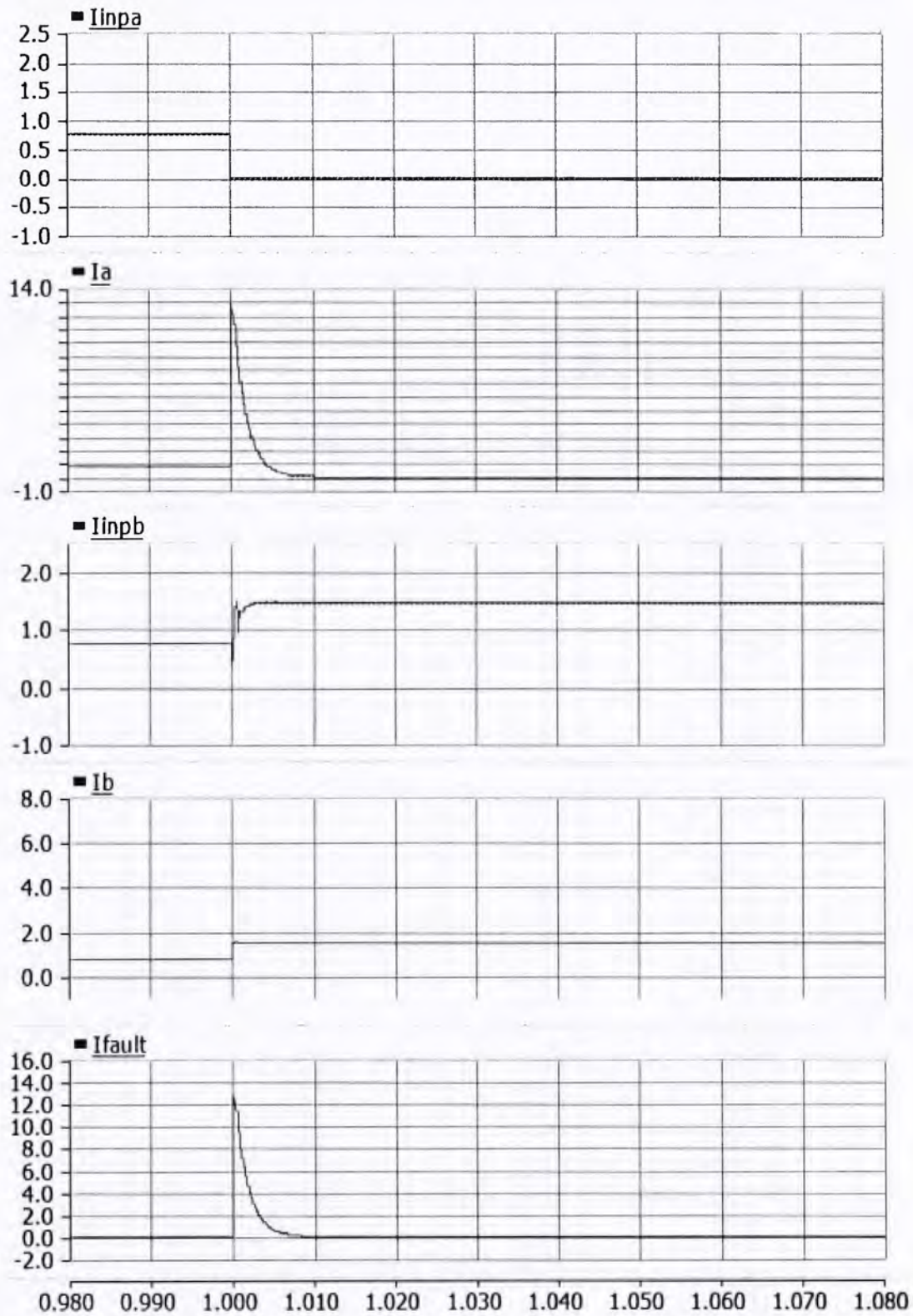

Figure 10. System response for a fault at location A with additional diodes on negative rail.

To verify the role of auctioneering diodes, circuitous currents and their effect on fault location, the simulated systems are assembled in the lab. The breaker box contains the design of Z-source breaker shown in Figure 4. The design specification for that are provided in Table I. For dc/dc converters, two simple buck converters are designed and assembled. The specifications for these buck converters are provided in Table II. Figure 11 shows the lab setup for these experiments. Prototype breaker box is shown in Figure 12. All experiments are obtained at converter input voltage of 220V, output voltage of 150V and load of 50Ω.

Table I. Z-source breaker parameters.

<b>Maximum Voltage</b>	<i>900VDC</i>
<b>Nominal current</b>	<i>30ADC</i>
<b>SCR turn off time</b>	<i>30μs</i>
<b>Inductor</b>	<i>1mH</i>
<b>Capacitor</b>	<i>50μF</i>
<b>Discharging resistor</b>	<i>2Ω</i>
<b>Charging resistor</b>	<i>100Ω</i>

Table II. Buck converter specifications.

<b>Inductor</b>	<b>Capacitor</b>	<b>Base load</b>	<b>Switching device</b>	<b>Switching frequency</b>
<i>2.2mH</i>	<i>200μF</i>	<i>2kΩ</i>	<i>IGBT module</i>	<i>10kHz</i>

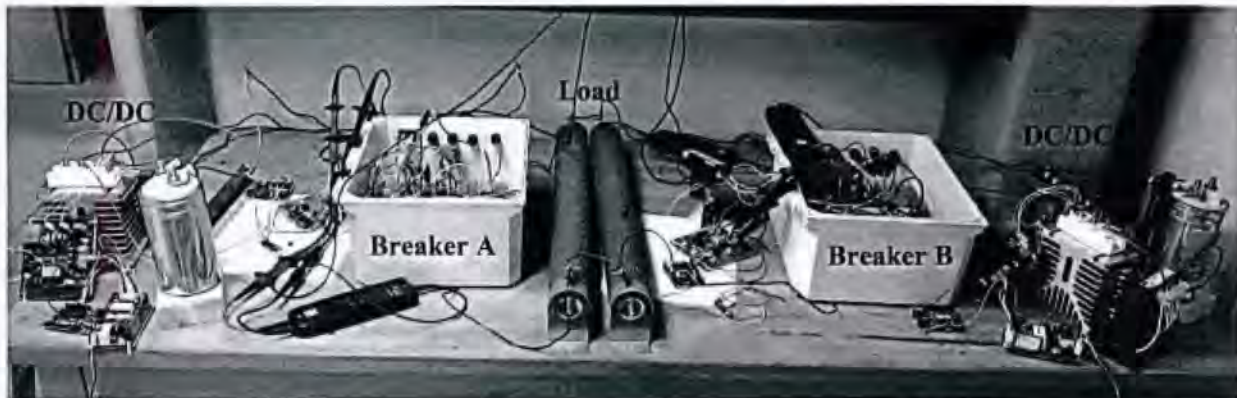

Figure 11. Laboratory setup with prototype breakers and dc/dc converters.



Figure 12. Prototype z-source breaker enclosure

Figure 13 shows the current waveforms corresponding to the laboratory setup where additional diodes are used to block circuitous current. The resulting waveforms look similar to the simulation results in Figure 10. The positive and negative rail currents are balanced. Only the breaker at the starboard bus opened and the current through the positive rail of the other breaker doubled to compensate for it. The waveforms in Figure 13 are labeled  $I_A$  to  $I_D$  corresponding to the Figure 5.

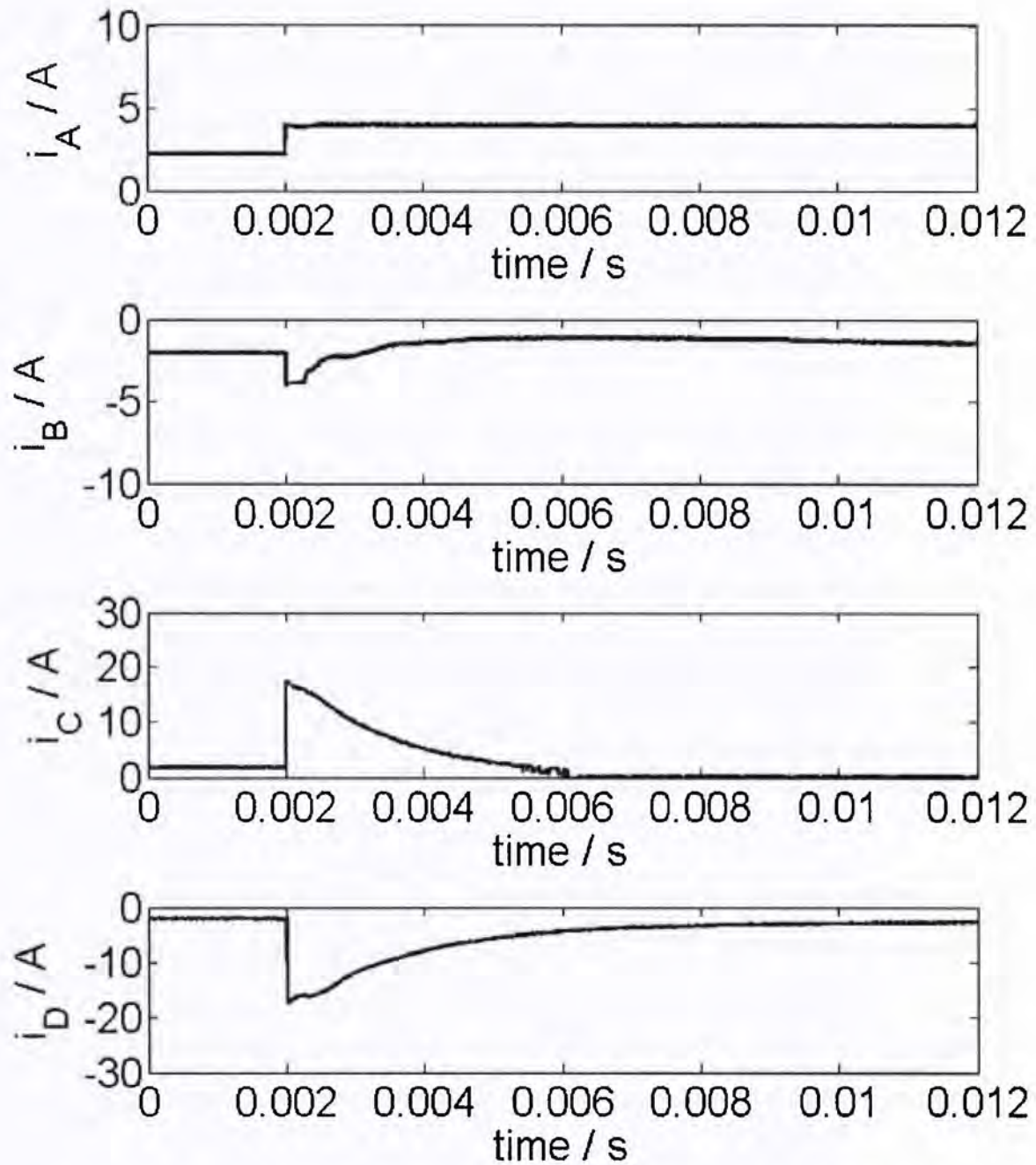

Figure 13. Current waveforms for lab setup with additional diodes in negative rail.

### Task 2: Breaker Reconfiguration Control

Task 2 states "A method for reconfiguration of circuit breakers that identifies circuitous currents will be developed. To whatever extent possible, the focus will be on autonomous control that can be implemented on each individual breaker. The control will be validated using the

simulation developed in Task 1. The reconfiguration method will then be tested on the laboratory setup."

From the previous task, the problem of circuitous current and its effect has been identified. The method of using additional diodes seems to have solved the problem from simulation and lab results but the additional diodes in the system are in the path of the steady-state current so that it would introduce some power losses. Another way to achieve optimum results using Z-source breakers is discussed in this section. Figure 7 shows that both of the breakers open even though the output currents differ significantly. There is a large spike in output of breaker A feeding the fault current caused by the capacitive discharge of the shunt capacitance in the Z-source breaker. In contrast to that, the output current of breaker B shows some increase, but compared with the steady-state current, it is only a slight change.

With this information known, the fault location can be determined by comparing the current with a preset threshold. The threshold value should be about four to five times the steady-state current. If both positive and negative rail currents exceed that threshold, it can be concluded that the fault is at the output terminals of the breaker and no action is necessary. However, if only the negative rail current exceeds that threshold, a flag will be set indicating that the breaker turned OFF due to a circuitous current and should be reclosed after a reasonable settling time. Table III presents the summary of required actions for fault locations simulated in locations shown in Figure 5.

Table III. Control action summary.

Fault Location	Port Breaker current response	Starboard breaker current response	Control Action
A	Both output current exceed threshold	Only negative rail current exceed threshold	Close Starboard side breaker after time $T$
B	Both output current exceed threshold	Both output current exceed threshold	No action required
C	Only negative rail current exceed threshold	Both output current exceed threshold	Close Starboard side breaker after time $T$

The advantage offered by this approach is higher efficiency during normal operation. The disadvantage is that the power to the load is interrupted for some time before being restored. It is

therefore important to categorize the loads as critical or noncritical. This approach should be preferred for noncritical load that can afford a small interruption in power without harming ships operation or a high current load where efficiency is a critical factor.

For the simulated system the output currents from the breakers are monitored to identify if the output current has exceeded the set threshold. In this way the breaker can identify the location of the fault with respect to the auctioneering diodes. The central control monitors these current signals from the breakers and resolves if any of the breakers need to be reclosed. In case of four-converter four-breaker system the zones have their own set of independent converters. In case of reclosing the breaker one of the converters doubles its load while the other converters remain unaffected.

In case of two-converter four-breaker system there are several load sharing possibilities. If the fault occurs at the location shown in Figure 1 and the objective of power sharing is to balance the load between port and starboard, then starboard converter would provide entire load of zone 2. This would mean that breaker C will have to provide double of its pre fault current. Similarly the port side converter will provide entire load of Zone 1 and breaker B will provide twice of its pre-fault current after reclosing. The current through breaker D will fall to zero and it will be open.

If the objective of power sharing is to ensure equal steady-state current through the breakers in zone 2 then the required power through the converters will need to be changed to 3:1. The port converter will provide the entire load of zone 1 as well as half the load of zone 2. The starboard converter will be providing only half the load of zone 2. This power sharing is simulated and the results are shown in Figure 13 for a fault at location shown in red in Figure 1. This power sharing is achieved in the simulation through modification of rated power in droop control of the buck converters. For the system in Figure 1b) each converter has its own breaker so the power ratios can stay 1:1 in every scenario. Figure 13 also shows a reclosing time of about 0.1s. Because of the complete independent orientation of breakers and converters in four-converter four-breaker system there is almost no disturbance in the output current of breaker C and D while the system opens and recloses as shown in Figure 13b). For the two-converter four-breaker system there is disturbance in the breaker currents of zone 2 even though the fault is in zone 1. These transients are a result of the converters trying to balance current between breakers C and D feeding zone 2.

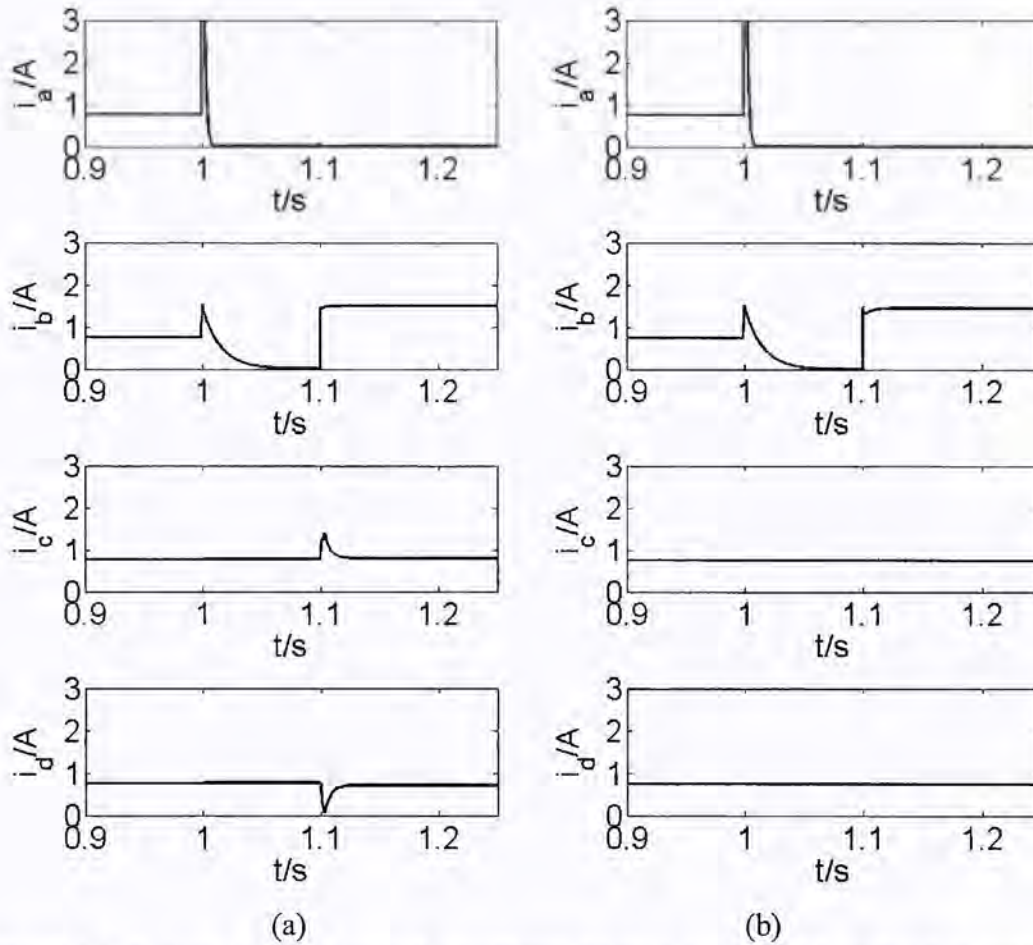

Figure 13. Z-source output current waveforms (a) two-converter four-breaker system  
(b) four-converter four-breaker system.

To verify the approach of fault location detection through lab setup, the output currents of both breakers in a single zone are measured using Hall effect sensors. The outputs of those sensors are compared with a set threshold voltage using analog comparators. Once a current crosses the threshold, the state is locked to indicate that a fault has occurred. The gate control device for each breaker will communicate this information to a central control. Based on the summary from Table 3, the central controlling device decides the appropriate action and sends the information back to the gate control device.

To implement the scheme from Table III, LEM current sensors are installed in the current path of the inductors in Z-source breaker. The current signals are processed to ensure their value stays between 0 and 5V which is the acceptable ADC input range for Arduino Uno device. The steady

state current in this experiment through each breaker is expected to be 1.5A. The current threshold is therefore programmed at ADC input of 2.5V which corresponds to roughly 5A. Once the current exceeds the threshold, the Arduino raises a flag and keeps sending this information to the central control until it receives a reset command. To communicate with the central control, the UART module of Arduino Uno is used. An HC-06 bluetooth device is connected to Arduino which sends and receives the data from another HC-06 device connected to the central control. The two Bluetooth devices need to be paired once before installation and after that they can automatically detect each other for future operations.

This local Arduino device is responsible for sending gate signals to the SCR in the breaker. The output current from Arduino device is not enough to drive the gate of an SCR so a current amplifier is made from a discrete BJT. The amplified signal then goes through a pulse transformer to provide isolation. A block diagram of the local control setup is shown in Figure 14.

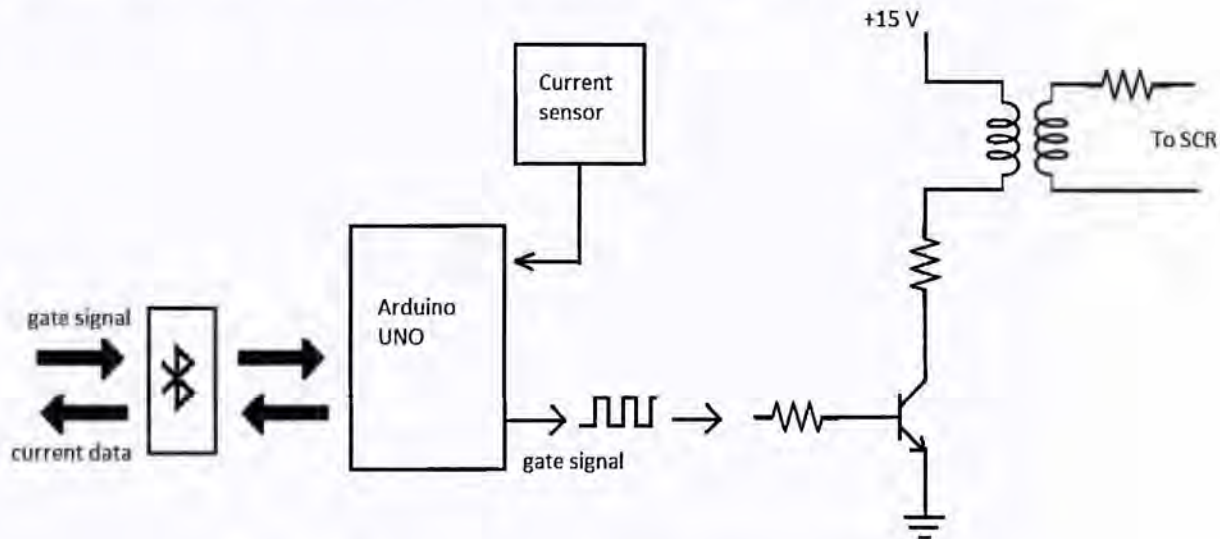

Figure 14. Block diagram of the local control on each breaker

The central control is setup about 10 feet away at another work bench. Each Hc-06 module from the breaker has its paired bluetooth module connected to another Arduino uno. In this setup there were two breakers used so one of the two arduinos is selected as the main controller. All the data is collected in that Arduino and it sends out the gate signals for the SCRs which are wirelessly communicated to the breakers. A settling time of 0.2s is programmed for the system in form of a delay in sending the reclosing signal when required. A block diagram is shown in Figure 15.

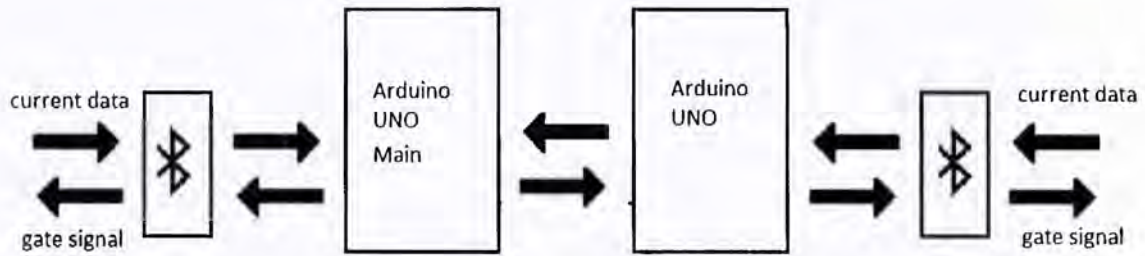

Figure 15. Block diagram of the central control for laboratory setup

Figure 16 shows the current sensors outputs corresponding to the current waveforms when the fault is created at location C from figure 5. It can be seen that initially both breakers turn OFF and this part of waveform is similar to Figure 7. After some settling time, the breaker at port side closes and starts conducting again. The return path of the current is shared between the two breakers.

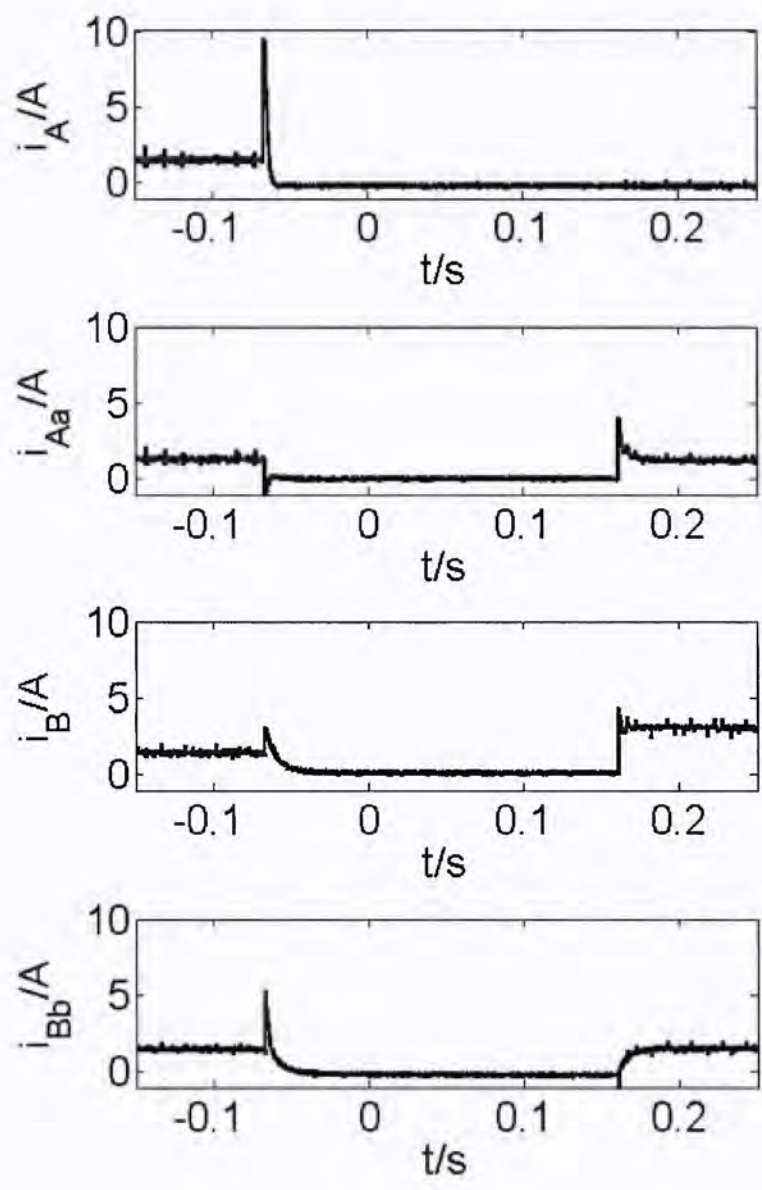

Figure 16. Breaker A and breaker B output currents at fault and re integration for fault location shown in Figure 1.

## **Conclusion**

Circuitous currents in galvanically non-isolated zonal systems create a number of issues that disturb fault protection schemes. These large common-mode currents not only are damaging in magnitude, they also cause protection systems to falsely turn OFF power converters and breakers supplying power from a healthy path. The first part of this work addresses creating a detailed simulation to observe circuitous currents in a zonal power system. The simulation showed multiple breakers switching off in response to a fault in one location; a false-positive situation. A low-voltage laboratory setup was created which verified the same false-positive breaker operation. A reconfiguration method was developed in the simulation and later applied to the laboratory system. Three fault scenarios were tested and a centralized control re-energizes the appropriate breakers to maintain remedial system operation.