

REPORT DOCUMENTATION PAGE			Form Approved OMB NO. 0704-0188		
<p>The public reporting burden for this collection of information is estimated to average 1 hour per response, including the time for reviewing instructions, searching existing data sources, gathering and maintaining the data needed, and completing and reviewing the collection of information. Send comments regarding this burden estimate or any other aspect of this collection of information, including suggestions for reducing this burden, to Washington Headquarters Services, Directorate for Information Operations and Reports, 1215 Jefferson Davis Highway, Suite 1204, Arlington VA, 22202-4302. Respondents should be aware that notwithstanding any other provision of law, no person shall be subject to any penalty for failing to comply with a collection of information if it does not display a currently valid OMB control number. PLEASE DO NOT RETURN YOUR FORM TO THE ABOVE ADDRESS.</p>					
1. REPORT DATE (DD-MM-YYYY) 03-12-2017		2. REPORT TYPE Final Report		3. DATES COVERED (From - To) 15-Jul-2016 - 14-Apr-2017	
4. TITLE AND SUBTITLE Final Report: Broadening the Efficiency Bandwidth Product of Electrically small Antenna through Direct Antenna Modulation (DAM) Transmitting			5a. CONTRACT NUMBER W911NF-16-1-0428		
			5b. GRANT NUMBER		
			5c. PROGRAM ELEMENT NUMBER 611102		
6. AUTHORS			5d. PROJECT NUMBER		
			5e. TASK NUMBER		
			5f. WORK UNIT NUMBER		
7. PERFORMING ORGANIZATION NAMES AND ADDRESSES University of California - Los Angeles Office of Contract and Grant Administration 11000 Kinross Avenue, Suite 211 Los Angeles, CA 90095 -1406			8. PERFORMING ORGANIZATION REPORT NUMBER		
9. SPONSORING/MONITORING AGENCY NAME(S) AND ADDRESS (ES) U.S. Army Research Office P.O. Box 12211 Research Triangle Park, NC 27709-2211			10. SPONSOR/MONITOR'S ACRONYM(S) ARO		
			11. SPONSOR/MONITOR'S REPORT NUMBER(S) 69469-EL-II.3		
12. DISTRIBUTION AVAILABILITY STATEMENT Approved for public release; distribution is unlimited.					
13. SUPPLEMENTARY NOTES The views, opinions and/or findings contained in this report are those of the author(s) and should not be construed as an official Department of the Army position, policy or decision, unless so designated by other documentation.					
14. ABSTRACT					
15. SUBJECT TERMS					
16. SECURITY CLASSIFICATION OF:		17. LIMITATION OF ABSTRACT		15. NUMBER OF PAGES	19a. NAME OF RESPONSIBLE PERSON
a. REPORT UU	b. ABSTRACT UU	c. THIS PAGE UU	UU		Yuanxun Wang
				19b. TELEPHONE NUMBER 310-206-5670	

**RPPR Final Report**  
as of 04-Dec-2017

Agency Code:

Proposal Number: 69469ELII

**Agreement Number: W911NF-16-1-0428**

**INVESTIGATOR(S):**

**Name:** PhD Yuanxun Ethan Wang

**Email:** ywang@ee.ucla.edu

**Phone Number:** 3102065670

**Principal:** Y

Organization: **University of California - Los Angeles**

Address: Office of Contract and Grant Administration, Los Angeles, CA 900951406

Country: USA

DUNS Number: 092530369

EIN: 956006143

**Report Date:** 14-Jul-2017

Date Received: 03-Dec-2017

**Final Report** for Period Beginning 15-Jul-2016 and Ending 14-Apr-2017

**Title:** Broadening the Efficiency Bandwidth Product of Electrically small Antenna through Direct Antenna Modulation (DAM) Transmitting

**Begin Performance Period:** 15-Jul-2016

**End Performance Period:** 14-Apr-2017

**Report Term:** 0-Other

Submitted By: PhD Yuanxun Wang

Email: ywang@ee.ucla.edu

Phone: (310) 206-5670

**Distribution Statement:** 1-Approved for public release; distribution is unlimited.

**STEM Degrees:** 2

**STEM Participants:** 2

**Major Goals:** This STIR proposal is to demonstrate high efficiency broadband HF transmission based on the novel concept of Direct Antenna Modulations (DAM). The proposed effort takes a system approach rather than isolated antenna design to attack the famous Chu-Harrington's limit e.g. the limit of efficiency bandwidth product, associated with electrically small antennas or radiation platforms.

The effort will bring forth innovations on both the operating principles and hardware architectures of HF transmitters. On the transmitter operating principles, the proposed efforts utilize the nonlinear, dynamic nature of device-antenna interactions to achieve antenna performance beyond conventional limits. It has been demonstrated that a high-speed switch can change the nature of a narrow-band resonant antenna to a high-speed pulse radiator. The so-called switched-mode antenna is capable of breaking the bandwidth limit of a high-Q system in a direct antenna modulation manner by introducing nonlinear dynamics in a synchronized fashion with the RF carrier to be transmitted. Circuit simulations and preliminary experiments have demonstrated that the efficiency bandwidth product limit of electrically small loop antennas can now be surpassed.

**Accomplishments:** During the funded project period, we have designed and implemented a frequency shift keying transmitter including electrically small loop antennas, high-speed GaN switches that work at 10MHz. We have demonstrated that the bandwidth limit of the original antenna in the order of 0.5% to 0.8% can now be broadened to greater than 10% while the efficiency remains to be good.

For details, please see the uploaded report.

**Training Opportunities:** We have trained an undergraduate student who now works in Hughes Research Lab (HRL) and supported a Ph.D student partially.

**Results Dissemination:** A conference paper on the relevant topic has been published in the IEEE Antennas and Propagation Symposium.

**Honors and Awards:** Nothing to Report

**Protocol Activity Status:**

**Technology Transfer:** Nothing to Report

**RPPR Final Report**  
as of 04-Dec-2017

**PARTICIPANTS:**

**Participant Type:** Undergraduate Student

**Participant:** Skyler Selvin

**Person Months Worked:** 6.00

**Funding Support:**

Project Contribution:

International Collaboration:

International Travel:

National Academy Member: N

Other Collaborators:

**Participant Type:** Graduate Student (research assistant)

**Participant:** Rui Zhu

**Person Months Worked:** 6.00

**Funding Support:**

Project Contribution:

International Collaboration:

International Travel:

National Academy Member: N

Other Collaborators:

**CONFERENCE PAPERS:**

**Publication Type:** Conference Paper or Presentation

**Publication Status:** 1-Published

**Conference Name:** IEEE Antennas and Propagation Symposium

Date Received: 03-Dec-2017      Conference Date: 11-Jul-2017

Date Published: 09-Jul-2017

Conference Location: San Diego, CA

**Paper Title:** Frequency Shift Keying for Direct Antenna Modulation (DAM) with Electrically Small Antenna

**Authors:** Rui Zhu; Skyler Selvin; Yuanxun Ethan Wang; Nian Guo

Acknowledged Federal Support: **N**



# Direct Antenna Modulation

Skyler Selvin, Rui Zhu, and Ethan Wang

## Introduction

Direct Antenna Modulation (DAM) eliminates some of the fundamental performance restrictions of an electrically small antenna. Conventionally, small antennas are driven with a tank circuit, and modulated by simply switching the power input to the circuit. DAM, however, modulates the signal by directly switching the current on the antenna. This creates a time variation in the topology of the resonant circuit and allows DAM to surpass the fundamental limits that describe time invariant systems.

This time-domain modification of the resonance circuit increases the bandwidth of the transmitter without effecting  $Q_{00}$ , the quality factor of the tank. (1) shows the bandwidth of a system that uses traditional modulation techniques, and (2) shows the improved bandwidth using a DAM system, where  $f_0$  is the center frequency and  $B$  is the bandwidth.

$$B_{\text{traditional}} \leq \frac{f_0}{Q_{00}} \quad (1)$$

$$B_{\text{DAM}} \leq f_0 \quad (2)$$

Due to the Chu-Harrington limit, electrically small antennas have small radiation resistance compared to reactance, and most of the input energy is stored in the near field. Any resistive loss in the driver circuitry is usually much greater than the radiation resistance itself, resulting in a relatively low emission efficiency  $\eta$ . The efficiency of a time invariant small antenna system is as follows, where  $W_X$  is the reactive energy in the near field of the antenna, and  $Q_{\text{ant}}$ , as described by Chu's limit, is the quality factor intrinsic to the antenna itself.

$$Q_{\text{ant}} = \omega \frac{W_X}{R_{\text{rad}}} \geq \frac{1}{(ka)^3} + \frac{1}{ka} \quad (3)$$

$$\eta = \frac{1}{BQ_{\text{ant}}} \quad (4)$$

Therefore, in order to achieve a larger bandwidth in a conventional modulation system, the efficiency of the system must be reduced. For DAM, however, (4) does not apply.

By Shannon's theorem, the capacity of a channel at a given amount of input power is proportional to its bandwidth and efficiency. Therefore, if the bandwidth is increased while the efficiency remains relatively the same, the capacity of the channel is increased. Consequently, Direct Antenna Modulation can provide an electrically small transmitter with a capacity that outperforms traditional techniques.

When implementing a DAM system, active components must be placed in the tank circuitry. These active components increase the losses, and decrease the efficiency. The crux of the design process is finding a way to reduce the impact of the active components. If the channel capacity that is required is relatively low, it can be advantageous to use traditional modulation schemes. However, at high data rates the increased bandwidth of DAM compensates for the added losses.

This report details the theory of a DAM system implemented with a matched loop antenna, as well as experimental results using commercially available parts.

## Theory

For this approach, we will consider a small loop antenna resonating with a capacitor. An inductor  $L_1$  coupled to the antenna  $L_2$  is used to drive the system while achieving a matched impedance (Fig. 1).

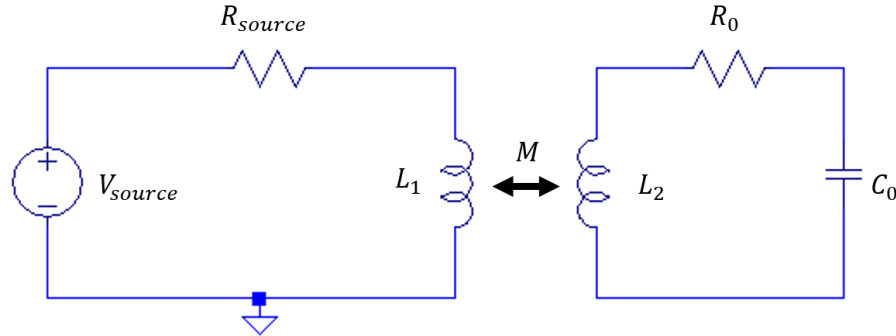

Figure 1: The basic design of a small antenna transmitter matched to a source resistance for maximum power output.

The series resistance of the inductor is modeled as  $R_0$ . If we assume that the quality factor of the circuit  $Q_{00}$  is large, then

$$\omega_0 \approx \frac{1}{\sqrt{L_2 C}} \quad (4)$$

$$Z_{in}(\omega_0) \approx \frac{L_1 k^2}{CR} \quad (5)$$

## BFSK

When transforming this system into DAM, the circuit takes on multiple states. For Binary Frequency Shift Keying (BFSK), the circuit takes on two states as shown in (Fig 2). This is the simplest form of DAM, and what is to be considered in this analysis.

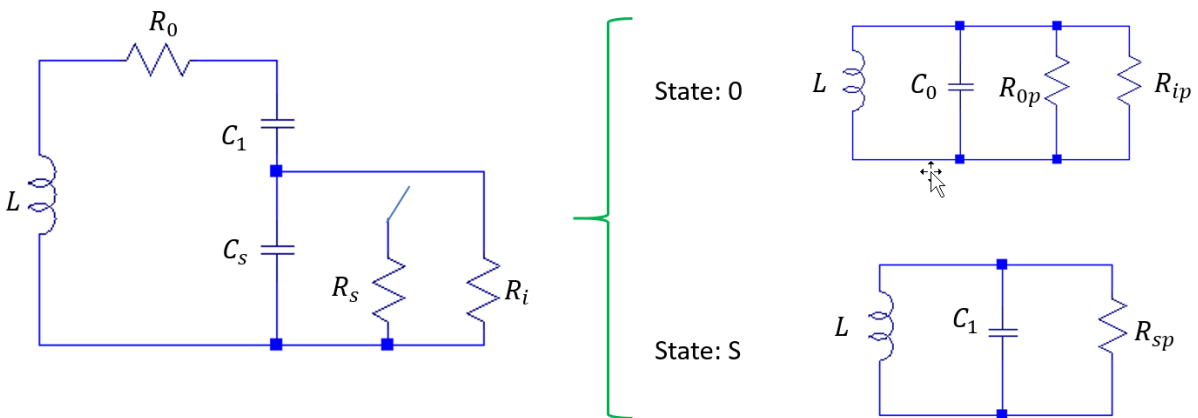

Figure 2: The two states of BFSK DAM and their equivalent parallel RLC circuits.

**Table 1: Definition of parameters**

$L$	Antenna Inductance
$C_0$	Series $C_1$ and $C_0$
$C_1$	Resonant Capacitance in STATE S
$C_s$	Capacitor which is shorted by switch
$R_s$	Resistance of closed switch
$R_i$	Resistance of open switch

This topology was chosen because it allows for a switch to have a breakdown voltage that is less than the voltage swing across the inductor  $V_{max}$ . For high  $Q$  systems, the voltage swing in the tank is very large, and may exceed the switches breakdown voltage. The values of the capacitors can be adjusted to accommodate any switch. If the switch's breakdown voltage is larger than the voltage swing, then there need only be one capacitor  $C_0$ , and the resonance of the circuit can be eliminated, extending the lower frequency to DC and the bandwidth to  $f_0 = \omega_0/2\pi$ . The larger the breakdown voltage of the switch, the lower the switching frequency  $f_s = \omega_s/2\pi$  (frequency in state S), and the greater the bandwidth of the system.

The input parameters for DAM transmitter are listed in (Table 2). The best results are obtained when  $R_s \rightarrow 0$  and  $R_i \rightarrow \infty$ .

**Table 2: Given Parameters**

Real Input power	$P$	<i>Watts</i>
Amplitude of voltage across switch	$V_{switch}$	<i>Volts</i>
Switch 'on' resistance	$R_s$	<i>Ohms</i>
Switch 'off' resistance	$R_i$	<i>Ohms</i>
Center Frequency of STATE 0	$\omega_0$	<i>rad/sec</i>
Initial Q of tank	$Q_{00}$	–
Capacitance of STATE 0	$C_0$	<i>Farads</i>

Note:  $V_{switch}$  is the amplitude of the sinusoidal voltage across the switch. This should be less than half the breakdown voltage of the switch.  $2V_{switch} < V_{breakdown}$

### Power and Maximum Voltage

The fractional bandwidth of DAM is determined solely by the ratio of the maximum switching voltage to the largest voltage in the tank  $V_{max}/V_{switch}$ . Each of the two states has a different voltage swing. In steady state, the voltage swing in each of the two states is

$$V_0 = \sqrt{\frac{2PQ_0}{\omega_0 C_0}} \quad V_s = \sqrt{\frac{2PQ_s}{\omega_s C_1}}$$

Each of these maximum voltages is proportional to the reactive energy stored in the circuit.

$$V_0 = \sqrt{\frac{2 * STATE 0 \text{ stored energy}}{C_0}} \quad V_s = \sqrt{\frac{2 * STATE S \text{ stored energy}}{C_1}}$$

After a STATE 0 or STATE S has reached the steady state, if the circuit is then switched to the other state (and no energy is lost in the switching action), the transient maximum voltages in each state are:

$$V_0 = \sqrt{\frac{2PQ_s}{\omega_s C_0}} = \sqrt{\frac{2 * STATE S \text{ stored energy}}{C_0}}$$

$$V_s = \sqrt{\frac{2PQ_0}{\omega_0 C_1}} = \sqrt{\frac{2 * \text{STATE 0 stored energy}}{C_1}}$$

Therefore, the absolute maximum voltage in the circuit is determined by which state stores the most energy. If  $Q_s/\omega_s > Q_0/\omega_0$ , then STATE S stores more energy and the maximum voltage in the circuit is found directly after switching from STATE S to STATE 0. However,  $Q_s \ll Q_0$  in most cases because STATE S includes the ON resistance of the switch. Therefore, the maximum voltage is usually found in the steady state of STATE 0 and is

$$V_{max} = V_0 = \sqrt{\frac{2PQ_0}{\omega_0 C_0}}$$

This analysis assumes that the input power  $P$  is the same in each of the states. However, in practical cases, the input impedance of the tank is different in each state. In order for each state to consume the same amount of power, the matching circuitry must be switched as well, and the source modulated. However, one option is to drive the system with only one of the two resonant frequencies  $\omega_s$  or  $\omega_0$ . The system will only consume power when in the state that resonates with the source, and energy from that state will be passed to the other after each switching. In this scenario, the so the time averaged real power would be half for 50% modulation. Given that the quality factor of each state is large, the state that does not resonant with the source will still resonant after switching for a reasonable amount of time (proportional to the quality factor). The main issue with this method is that if the state is not switched back to the source frequency, the circuit will cease to resonate. However, with 50% modulation and high quality factors, driving the circuit with one frequency is a viable option.

### Bandwidth and Efficiency

With the given parameters, we can find the quality factor of each state, as well as the bandwidth of the DAM system  $B_{DAM}$ .

$$B_{DAM} \approx \omega_0 - \omega_s = \omega_0(1 - \alpha) \quad (6)$$

$$C_1 = \frac{C_0}{\alpha^2} \quad C_s = \frac{C_0}{1 - \alpha^2} \quad (7)$$

$$V_0^2 = \frac{2PQ_0}{\omega_0 C_0} \quad (8)$$

$$\alpha = \sqrt{1 - \frac{V_{switch}}{V_0}} = \sqrt{1 - V_{switch} \sqrt{\frac{\omega_0 C_0}{2PQ_0}}} \quad (9)$$

A greater switching voltage yields a larger bandwidth at a given amount of input power. The quality factors of each state are

$$Q_0 = \omega_0 C_0 (R_{ip} || R_{op}) \quad (10)$$

$$Q_s = \frac{\omega_0 C_0 R_{sp}}{\alpha} \quad (11)$$

$$R_{0p} = \frac{Q_{00}}{\omega_0 C_0} \quad (12)$$

$$R_{ip} = \frac{R_i}{(1 - \alpha^2)^2} \quad (13)$$

$$R_{sp} = \frac{\alpha^2}{\omega_0^2 C_0^2 (R_{0s} + R_s)} \quad (14)$$

Where  $R_{0s} = \alpha Q_{0s}/(\omega_0 C_0)$  is the inherent resistance in the antenna at the switching frequency, and  $Q_{0s}$  is the quality factor of the tank at  $\omega_s$ . This is likely to be less than  $R_0$  because of the skin and proximity effects.

If we make the assumption that the open resistance of the switch  $R_i \rightarrow \infty$  and the inherent resistances are the same  $R_0 = R_{0s}$ , the equations for the quality factors reduce to the following:

$$Q_0 = \frac{1}{\omega_0 C_0 R_0} \quad (15)$$

$$Q_s = \frac{\alpha}{1/Q_0 + \omega_0 C_0 R_s} \quad (16)$$

As for the quality factor of the entire DAM system  $Q_{DAM}$ , for 50% modulation, or equal amount of time in each state, this is merely the average of the quality factors in each state.

$$Q_{DAM} = \frac{Q_0}{2} + \frac{1}{2} \frac{1}{1/Q_0 + \omega_0 C_0 R_s} \alpha \quad (17)$$

Since  $\alpha = 1 - B_{DAM}/\omega_0$ , it is clear that  $Q_{DAM}$  is linearly proportional to the bandwidth. Therefore, the efficiency is also linearly related to the bandwidth, as opposed the hyperbolic relation in (4) for conventional antennas. The efficiency of DAM is the average of the efficiency of each state.

$$\eta_0 = \frac{1}{B_0 Q_{ant}} = \frac{Q_0}{Q_{ant}} \quad \eta_s = \frac{1}{B_s Q_{ant}} = \frac{Q_s}{Q_{ant}}$$

$$\eta_{DAM} = \frac{Q_{DAM}}{Q_{ant}} \quad (18)$$

Where  $B_0$  and  $B_s$  are the bandwidths of STATE 0 and STATE S respectively. The efficiency of the DAM system is lower at low data rates. However, for high data rates the efficiency of DAM far outperforms traditional modulation techniques. Figure 3 shows the efficiency for DAM verses conventional modulation.

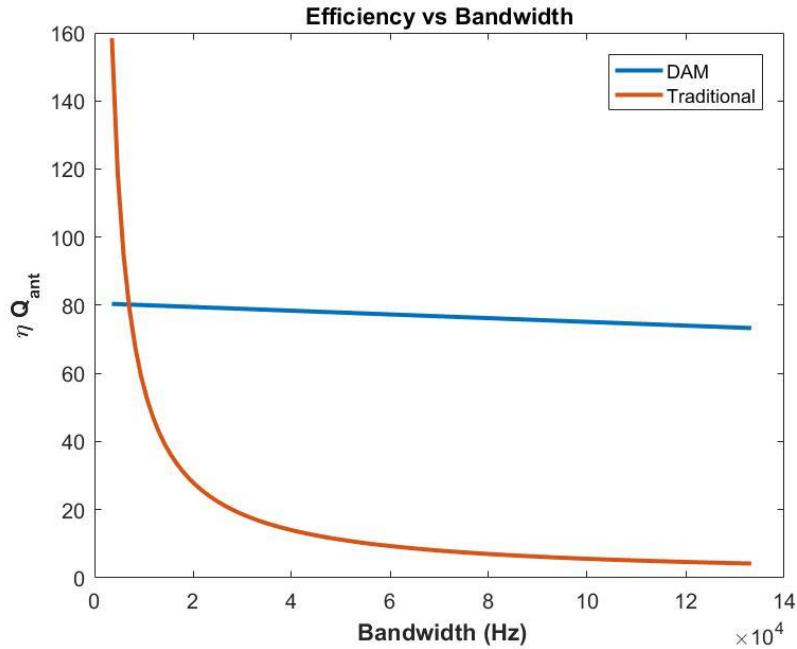

Figure 3: The normalized efficiency vs the bandwidth of traditional and DAM transmitters.  $Q_{ant}$  is a constant and dependent on the geometry of the antenna. The bandwidth here is increased by increasing the switching voltage from 3 to 100 volts.  $f_0 = 560 \text{ kHz}$ ,  $Q_{00} = Q_0 = 100$ ,  $C_0 = 1 \text{ nF}$ ,  $R_i = \infty$ ,  $R_s = 1.8 \Omega$ ,  $P = 1 \text{ W}$ ,  $V_0 = 238 \text{ V}$ .

For this example, the open resistance of the switch is infinity, and the losses by changing the driver to DAM are due to the switch ‘on’ resistance alone. At lower bandwidths, the efficiency of a traditional scheme is better, but as the capacity requirements increase, DAM will provide better efficiency for larger bandwidths.

### Switching time

If there is a voltage across  $C_s$  when the switch is closed, that energy will be dissipated in the switch. The best time to switch is when there is no voltage across the capacitors.

Note: All the above analysis was confirmed with both experimental results and simulation in Advance Design System.

## Experimental Results

Many antennas were built and tested in order to get a reasonably high initial quality factor of the tank  $Q_{00}$ . The best results were obtained by using a AM radio ferrite antenna rod. In the range of frequencies of interest (<700 kHz) the antenna’s quality factor is approximately constant.

$$Q_{00} \approx 450$$

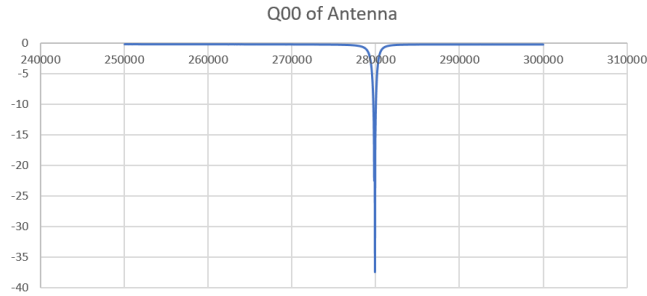

### Direct Antenna Modulation

Figure 4 shows the circuit diagram and the setup that was built. The main radiating element  $L_2$  has much larger inductance than either  $L_0$  or  $L_s$ .

$$L_2 = 90 \mu\text{H}$$

$$L_0 = 0.5 \mu\text{H} \quad L_s = 0.9 \mu\text{H}$$

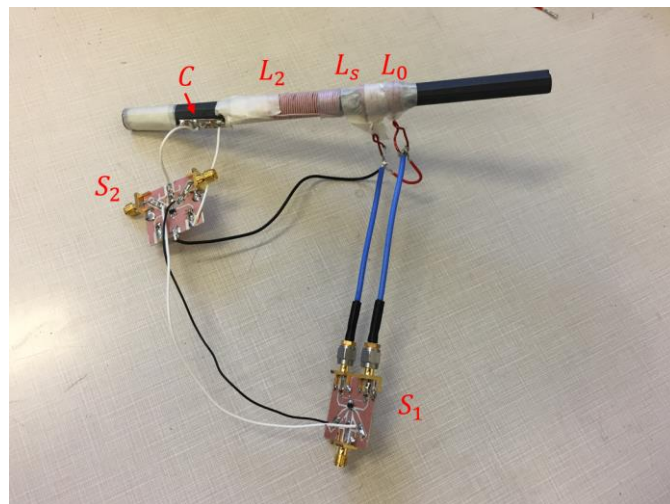
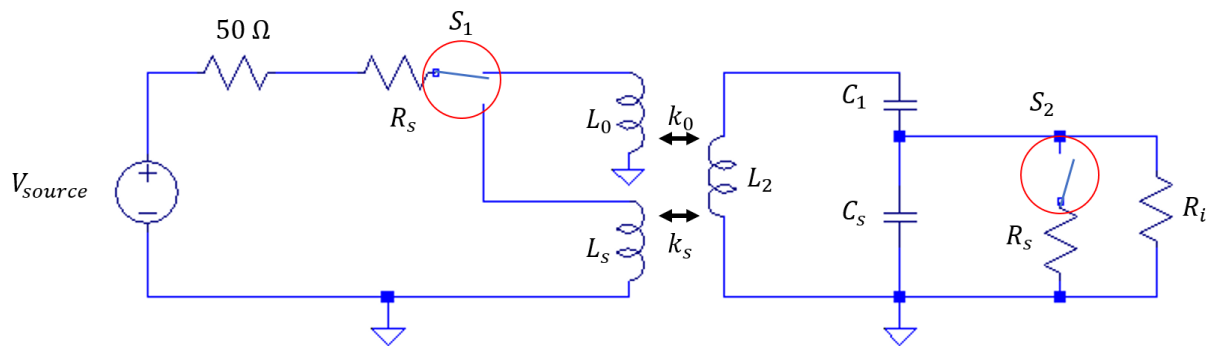

Figure 4: The system and circuit diagram. The circuit is matched in both STATE 0 and STATE S by switching the matching circuitry with  $S_1$ . Coupling between the inductors is shown as  $k_0$  and  $k_s$ . The coupling between  $L_0$  and  $L_s$  does not significantly change the behavior of the circuit, but will reduce  $Q_{00}$ .

By (5), changing the capacitance by switching  $C_s$  changes in input impedance of the circuit. In order to maintain  $50\Omega$  matching to the source in each state, the matching is switched simultaneously by throwing  $S_1$ .

The HMC595A double pole double throw (SPDT) switch was used for both  $S_1$  and  $S_2$ . HMC595A was chosen for its low ‘on’ resistance of  $1.5$  to  $3\ \Omega$ , large off resistance  $R_i$  measured to be  $50\ k\Omega$ , and breakdown voltage of  $\sim 25V$ .

The circuit was designed to resonate at  $f_0 = 560\ \text{kHz}$  with a capacitance  $C_0 = 1\ nF$ . The fractional bandwidth was chosen to be  $1/2$  to allow a half duty cycle square wave to drive the switches.

$$\alpha = 0.5$$

$$C_1 = 4\ nF \quad C_s = 1.33\ nF$$

The quality factor for each of the two states was found to be:

$$Q_0 = 173 \quad Q_s = 63 \quad \rightarrow \quad Q_{DAM} = 118$$

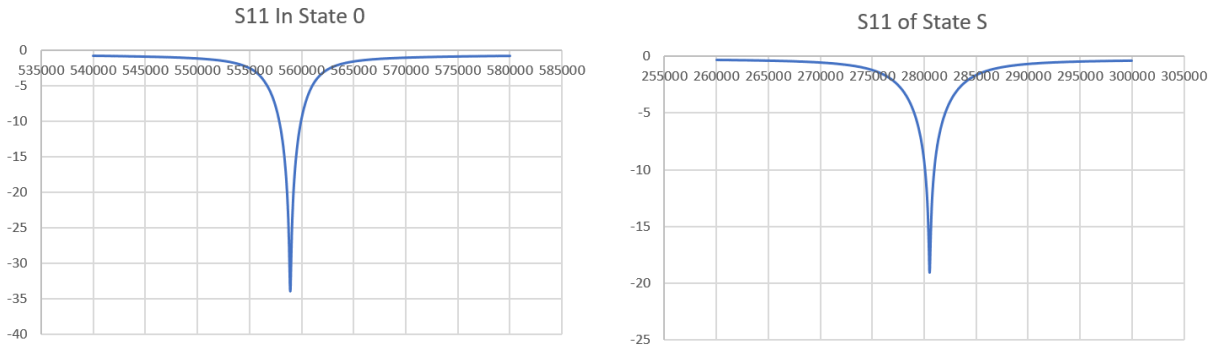

In this case, the ‘off’ resistance of the switch  $R_i$  causes considerable loss in the tank circuit. The fact that alpha is 0.5 increases the effective off resistance by a factor of  $1/(1 - \alpha^2)^2 = 1.77$ . With the switch off resistance of about  $50\ k\Omega$ , equations (10), (12) and (13) yield a predicted quality factor of  $Q_0 = 185$ . As for STATE S,  $R_{0s} \approx R_0 - 0.3\ \Omega = 0.3\ \Omega$ . With a switch resistance  $R_{switch} = 2\ \Omega$ , equations (11) and (14) yield a theoretical prediction of  $Q_s = 61$ , which is very close to the measured value.

The source waveform was switched in sync with the circuit. The signal was received by a loop coupled to near field of the antenna. The received waveform is shown in Figure 5 and 6 with  $P = 4\ \text{dBm}$ .

Two different receivers were used. The first, shown in Figure 5, was a small loop of approximately  $1.3\ \mu H$ . It was placed directly on the antenna rod and lightly coupled to  $L_2$ . The second, shown in Figure 6, was a large loop about 27 cm in diameter. It was used to detect the near field of the antenna at a greater range.

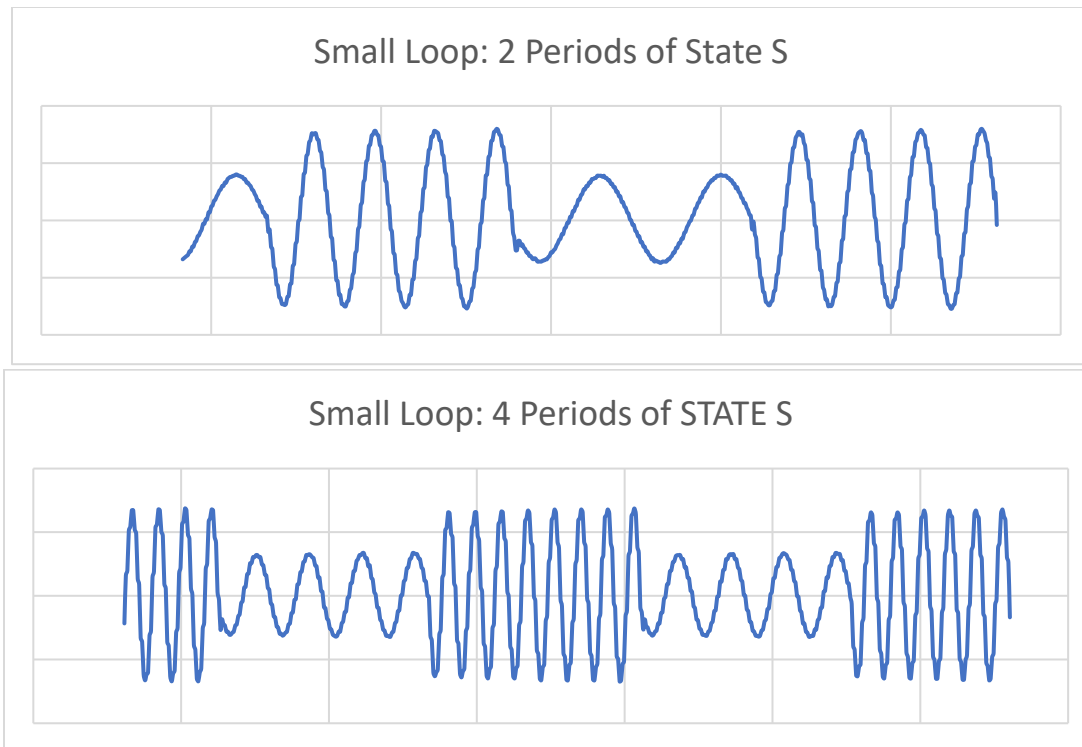

(a)

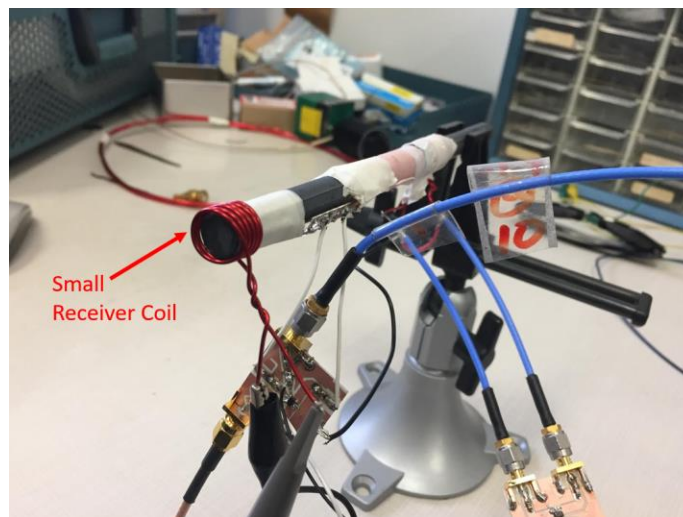

(b)

Figure 5: Received signal of Direct Antenna Modulation with 50% modulation at half bandwidth, with transmitter placed directly inside the small loop receiver. Receiver is shown in (b). The jitter seen in the waveform is an artifact of oscilloscope used to measure the signal.

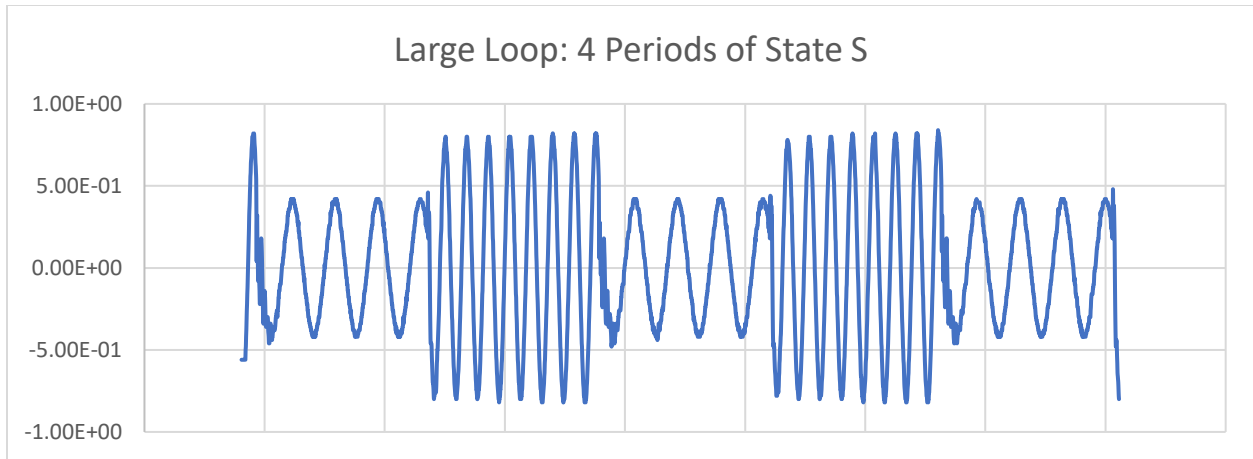

(a)

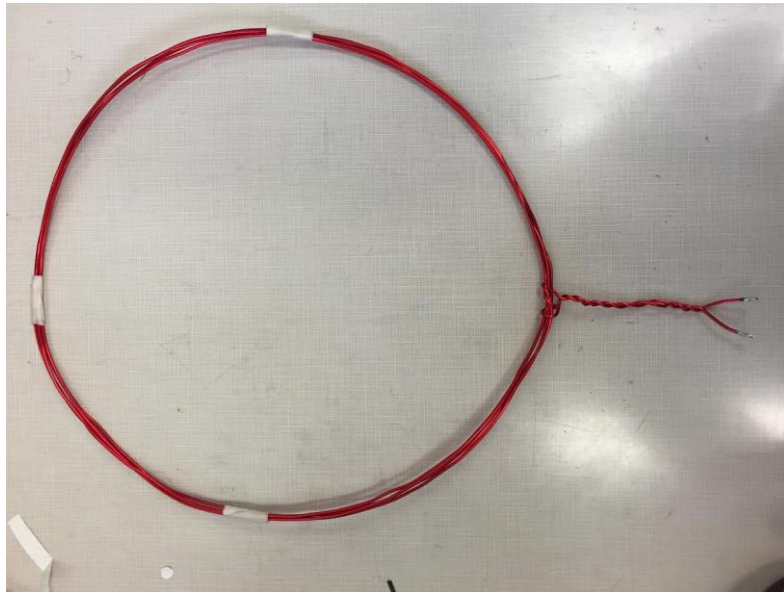

(b)

Figure 6: (a): Received signal of Direct Antenna Modulation with 50% modulation at half bandwidth, with transmitter placed directly inside the large loop receiver. Receiver is shown in (b).

The capacitance is 4 times as much as in STATE S, and therefore, if no energy is lost in switching, the peak voltage in STATE 0 should be 2 times the peak voltage in STATE S. Inspection of the waveforms reveal that this is indeed the case.

Since  $Q_s/\omega_s < Q_0/\omega_0$ , there can be more energy stored in the high frequency state. We can see a slight increase in amplitude of STATE 0 as it replaces some of the energy lost in STATE S.

If the circuit is changed so that it is tuned to the frequency of STATE 0 only (by disconnecting  $S_1$  from  $L_s$ ), then the system only receives power half the time, and we can see a noticeable drain in power in STATE S (Figure 7).

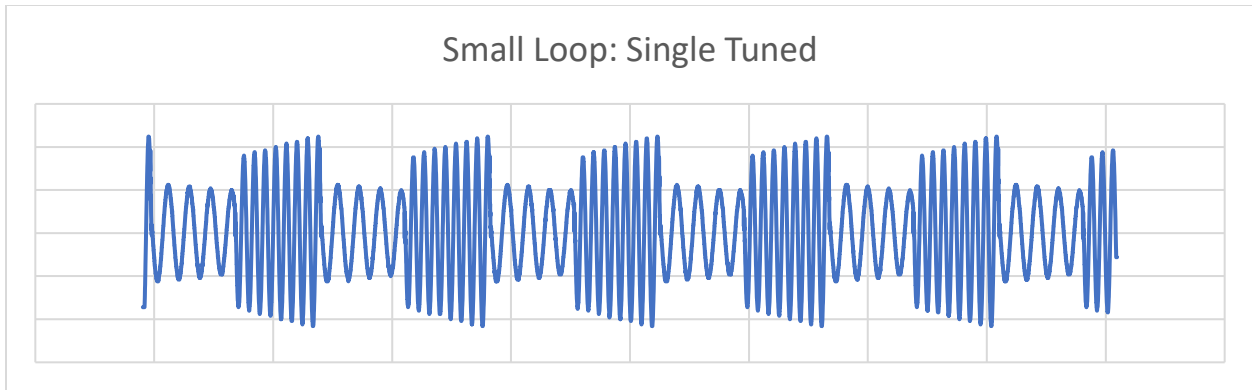
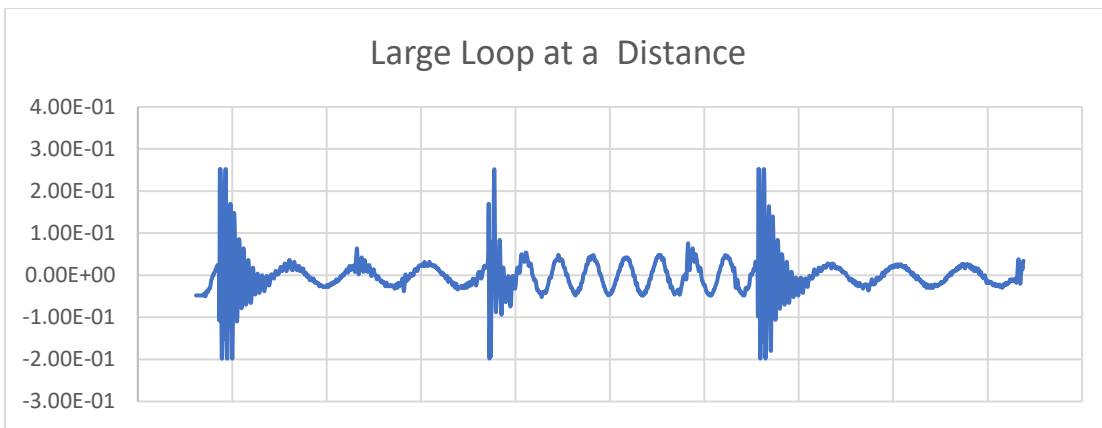
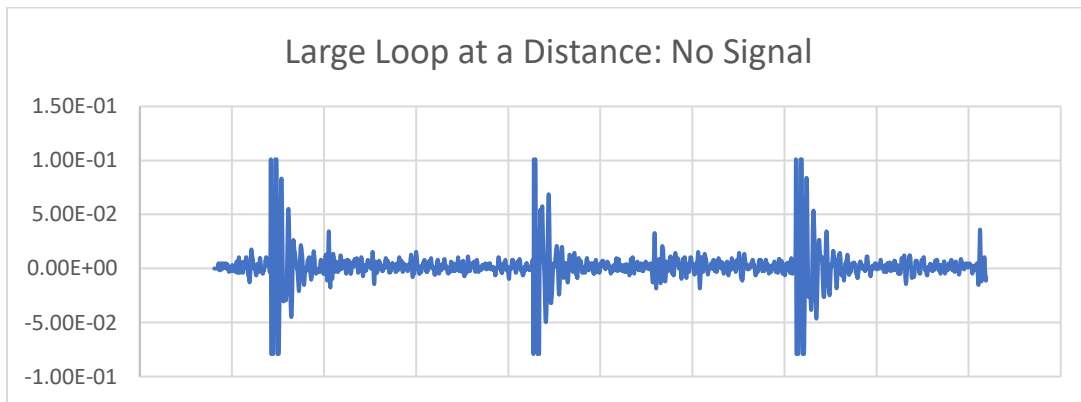

Figure 7: Received signal of Direct Antenna Modulation with input power in STATE 0 only. The small loop receiver was used.

When the receiver is placed at a distance, the switch noise dominates the signal as shown in Figure 8. Even when the input signal was turned off, the noise from the switches continue to flood the receiver with noise.



(a)



(b)

Figure 8: (a): Received signal at a distance from the transmitter. (b) Switching noise at the same distance.

## Conclusion

Direct Antenna Modulation can vastly increase the capacity of a small antenna transmitter. However, DAM still has very important limitations set by the active components. For a given switching voltage, the bandwidth  $B$  is limited by the input power. Because of the power power-bandwidth limitation, a DAM system is most easily applied to small antenna communication system that uses the near field.