



**NAVAL  
POSTGRADUATE  
SCHOOL**

**MONTEREY, CALIFORNIA**

**THESIS**

**DEVELOPMENT OF OPTIMAL STRESSOR  
SCENARIOS FOR NEW OPERATIONAL ENERGY  
SYSTEMS**

by

Geoffrey E. Fastabend

December 2017

Thesis Advisor:

Alejandro S. Hernandez

Second Reader:

Eugene P. Paulo

**Approved for public release. Distribution is unlimited.**

THIS PAGE INTENTIONALLY LEFT BLANK

<b>REPORT DOCUMENTATION PAGE</b>			<i>Form Approved OMB No. 0704-0188</i>	
Public reporting burden for this collection of information is estimated to average 1 hour per response, including the time for reviewing instruction, searching existing data sources, gathering and maintaining the data needed, and completing and reviewing the collection of information. Send comments regarding this burden estimate or any other aspect of this collection of information, including suggestions for reducing this burden, to Washington headquarters Services, Directorate for Information Operations and Reports, 1215 Jefferson Davis Highway, Suite 1204, Arlington, VA 22202-4302, and to the Office of Management and Budget, Paperwork Reduction Project (0704-0188) Washington, DC 20503.				
<b>1. AGENCY USE ONLY</b> <i>(Leave blank)</i>	<b>2. REPORT DATE</b> December 2017	<b>3. REPORT TYPE AND DATES COVERED</b> Master's Thesis		
<b>4. TITLE AND SUBTITLE</b> <b>DEVELOPMENT OF OPTIMAL STRESSOR SCENARIOS FOR NEW OPERATIONAL ENERGY SYSTEMS</b>			<b>5. FUNDING NUMBERS</b>	
<b>6. AUTHOR(S)</b> Geoffrey E. Fastabend				
<b>7. PERFORMING ORGANIZATION NAME(S) AND ADDRESS(ES)</b> Naval Postgraduate School Monterey, CA 93943-5000			<b>8. PERFORMING ORGANIZATION REPORT NUMBER</b>	
<b>9. SPONSORING /MONITORING AGENCY NAME(S) AND ADDRESS(ES)</b> N/A			<b>10. SPONSORING / MONITORING AGENCY REPORT NUMBER</b>	
<b>11. SUPPLEMENTARY NOTES</b> The views expressed in this thesis are those of the author and do not reflect the official policy or position of the Department of Defense or the U.S. Government. IRB number ____N/A____.				
<b>12a. DISTRIBUTION / AVAILABILITY STATEMENT</b> Approved for public release. Distribution is unlimited.			<b>12b. DISTRIBUTION CODE</b>	
<b>13. ABSTRACT (maximum 200 words)</b>  This thesis leverages a previously developed and tested simulation model for operational energy related systems in order to develop better stressor scenarios for acceptance testing. Analyzing the previous model using a design of experiments (DOE) and regression analysis provides critical information about the associated operational environment factors and their relationships that directly affected system performance. A nearly orthogonal Latin hypercube (NOLH) is used to expeditiously and effectively understand the entirety of the scenario space. This experimentation method identifies the most stressful combinations of the operational factors that can be used to test system performance. Under these maximally severe scenarios, a revised set of system requirements emerge from experimentation. The resulting system requirements can be used to revisit the design requirements and develop a more robust system. This process can be adopted by testing and acceptance agencies to further examine new technologies.				
<b>14. SUBJECT TERMS</b> systems engineering, modeling, simulation, foraging, nearly orthogonal Latin hypercube, ExtendSim			<b>15. NUMBER OF PAGES</b> 59	
			<b>16. PRICE CODE</b>	
<b>17. SECURITY CLASSIFICATION OF REPORT</b> Unclassified	<b>18. SECURITY CLASSIFICATION OF THIS PAGE</b> Unclassified	<b>19. SECURITY CLASSIFICATION OF ABSTRACT</b> Unclassified	<b>20. LIMITATION OF ABSTRACT</b> UU	

NSN 7540-01-280-5500

Standard Form 298 (Rev. 2-89)  
Prescribed by ANSI Std. Z39-18

THIS PAGE INTENTIONALLY LEFT BLANK

**Approved for public release. Distribution is unlimited.**

**DEVELOPMENT OF OPTIMAL STRESSOR SCENARIOS FOR NEW  
OPERATIONAL ENERGY SYSTEMS**

Geoffrey E. Fastabend  
Lieutenant, United States Navy  
B.S., United States Naval Academy, 2011

Submitted in partial fulfillment of the  
requirements for the degree of

**MASTER OF SCIENCE IN SYSTEMS ENGINEERING**

from the

**NAVAL POSTGRADUATE SCHOOL  
December 2017**

Approved by: Alejandro S. Hernandez  
Thesis Advisor

Eugene P. Paulo  
Second Reader

Ronald E. Giachetti  
Chair, Department of Systems Engineering

THIS PAGE INTENTIONALLY LEFT BLANK

## **ABSTRACT**

This thesis leverages a previously developed and tested simulation model for operational energy related systems in order to develop better stressor scenarios for acceptance testing. Analyzing the previous model using a design of experiments (DOE) and regression analysis provides critical information about the associated operational environment factors and their relationships that directly affected system performance. A nearly orthogonal Latin hypercube (NOLH) is used to expeditiously and effectively understand the entirety of the scenario space. This experimentation method identifies the most stressful combinations of the operational factors that can be used to test system performance. Under these maximally severe scenarios, a revised set of system requirements emerge from experimentation. The resulting system requirements can be used to revisit the design requirements and develop a more robust system. This process can be adopted by testing and acceptance agencies to further examine new technologies.

THIS PAGE INTENTIONALLY LEFT BLANK

# TABLE OF CONTENTS

<b>I.</b>	<b>INTRODUCTION.....</b>	<b>1</b>
<b>A.</b>	<b>PURPOSE.....</b>	<b>1</b>
<b>B.</b>	<b>BACKGROUND.....</b>	<b>1</b>
<b>C.</b>	<b>MODELING AND SIMULATION.....</b>	<b>3</b>
<b>D.</b>	<b>OBJECTIVES OF THE STUDY.....</b>	<b>4</b>
<b>E.</b>	<b>BENEFITS.....</b>	<b>4</b>
<b>F.</b>	<b>ORGANIZATION.....</b>	<b>5</b>
<b>II.</b>	<b>LITERATURE REVIEW.....</b>	<b>7</b>
<b>A.</b>	<b>OVERVIEW.....</b>	<b>7</b>
<b>B.</b>	<b>PROBLEMS EMERGING FROM INADEQUATE TESTING.....</b>	<b>7</b>
<b>C.</b>	<b>CURRENT FORAGING TECHNOLOGIES.....</b>	<b>9</b>
<b>1.</b>	<b>Examples of Dismounted Gear.....</b>	<b>9</b>
<b>2.</b>	<b>Examples of Mounted Gear.....</b>	<b>11</b>
<b>D.</b>	<b>CURRENT WATER FORAGING MODEL.....</b>	<b>12</b>
<b>III.</b>	<b>METHODOLOGY.....</b>	<b>13</b>
<b>A.</b>	<b>OVERVIEW.....</b>	<b>13</b>
<b>B.</b>	<b>ENHANCING THE PREVIOUS FORAGING SIMULATION MODEL.....</b>	<b>14</b>
<b>1.</b>	<b>Baseline Model.....</b>	<b>14</b>
<b>2.</b>	<b>Foraging Model.....</b>	<b>14</b>
<b>3.</b>	<b>Disruptions.....</b>	<b>15</b>
<b>C.</b>	<b>LEVERAGING THE DEVELOPED MODEL.....</b>	<b>16</b>
<b>1.</b>	<b>Overview.....</b>	<b>16</b>
<b>2.</b>	<b>Measure of Effectiveness.....</b>	<b>16</b>
<b>3.</b>	<b>Factors.....</b>	<b>17</b>
<b>D.</b>	<b>EXPERIMENTATION.....</b>	<b>18</b>
<b>IV.</b>	<b>ANALYSIS.....</b>	<b>21</b>
<b>A.</b>	<b>OVERVIEW.....</b>	<b>21</b>
<b>B.</b>	<b>REGRESSION ANALYSIS.....</b>	<b>21</b>
<b>1.</b>	<b>Reserve Index.....</b>	<b>21</b>
<b>2.</b>	<b>Preparation Index.....</b>	<b>23</b>
<b>C.</b>	<b>NEARLY ORTHOGONAL LATIN HYPERCUBE.....</b>	<b>25</b>
<b>1.</b>	<b>Reserve Index.....</b>	<b>26</b>
<b>2.</b>	<b>Preparation Index.....</b>	<b>27</b>

<b>D.</b>	<b>NEW REQUIREMENTS .....</b>	<b>28</b>
<b>1.</b>	<b>Stressor Configuration 180 .....</b>	<b>29</b>
<b>2.</b>	<b>Stressor Configuration 179 .....</b>	<b>31</b>
<b>3.</b>	<b>Resulting Foraging Designs.....</b>	<b>33</b>
<b>V.</b>	<b>CONCLUSIONS AND RECOMMENDATIONS.....</b>	<b>35</b>
<b>A.</b>	<b>CONCLUSIONS .....</b>	<b>35</b>
<b>B.</b>	<b>RECOMMENDATIONS.....</b>	<b>36</b>
	<b>LIST OF REFERENCES .....</b>	<b>39</b>
	<b>INITIAL DISTRIBUTION LIST .....</b>	<b>41</b>

## LIST OF FIGURES

Figure 1.	Platoon Water Purification System (PWPS). Source: Blanchard (2012).....	10
Figure 2.	Squad Water Purification System (SWPS). Source: MSR Guardian (2015).....	11
Figure 3.	Platoon Water Purification System (PWPS). Source: TECWAR (2016).....	12
Figure 4.	Simulation Model of Baseline System. Source: Soh (2017).....	14
Figure 5.	Simulation Model of Foraging System. Source: Soh (2017).....	15
Figure 6.	Calculation of RI and PI .....	17
Figure 7.	Regression Analysis RI.....	22
Figure 8.	Two-Way Interaction Plot for RI.....	23
Figure 9.	Regression Analysis PI.....	24
Figure 10.	Two-Way Interaction Plot for PI .....	25
Figure 11.	OLH Example .....	26
Figure 12.	Configuration 180 Regression Analysis on System Requirements for RI.....	29
Figure 13.	Configuration 180 Two-Way Comparison RI .....	30
Figure 14.	Configuration 179 Regression for PI.....	31
Figure 15.	Configuration 179 Two-way comparison PI.....	32

THIS PAGE INTENTIONALLY LEFT BLANK

## LIST OF TABLES

Table 1.	MOEs and MOPs of the MEU Resupply System .....	16
Table 2.	Operational Environment Factors .....	17
Table 3.	DOE Values .....	18
Table 4.	Excerpt of Results from NOLH RI Stressor Configurations .....	27
Table 5.	Excerpt of Results from NOLH PI Stressor Configurations.....	27
Table 6.	System Factors .....	29
Table 7.	New System Configuration for Success in RI under Stressor Scenario 180.....	31
Table 8.	New System Configuration for Improved PI under Stressor Configuration 179 .....	32
Table 9.	Stressor Scenario-Based Requirements .....	33

THIS PAGE INTENTIONALLY LEFT BLANK

## LIST OF ACRONYMS AND ABBREVIATIONS

DC	direct current
DOD	Department of Defense
DOE	design of experiments
FOB	forward operating base
IWPS	individual water purification system
M&S	modeling and simulation
MEU	Marine expeditionary unit
MOE	measure of effectiveness
MOP	measure of performance
NOLH	nearly orthogonal Latin hypercube
OE	operational energy
OLH	orthogonal Latin hypercube
OT&E	operational testing and evaluation
PI	preparedness index
PWPS	platoon water purification system
RI	reserve index
RO	reverse osmosis
SEED	simulation experiments and efficient designs
SoS	system of systems
SWPS	squad water purification system
T&E	testing and evaluation
USMC	United States Marine Corps

THIS PAGE INTENTIONALLY LEFT BLANK

## EXECUTIVE SUMMARY

Multiple systems like the Stryker Mobile Gun System (MGS) have been met with multiple design problems and testing issues during development. In order to prevent design problems and ensure systems will perform in real-world situations, the proper design of testing scenarios is required. By leveraging previously designed and tested models, more stressful scenarios for acceptance testing can be developed. Operational Energy (OE) and foraging technologies are actively being pursued and studied, and one of these developed models is the basis for this thesis.

The current employed foraging technology is insufficient to complete mission objectives in an extreme stressor scenario (i.e., high temperature, difficult terrain). It is not recommended for use in any situation where a forward operating base (FOB) could come under fire. There is insufficient available time for Marines to forage in a hostile combat zone. Foraging difficulties will continue until the output capacities of the individual foraging technology can improve. It is also recommended that feasibility be re-examined with a refined model to capture more accurately events on an hourly timeline instead of on a daily one. By refining the model, more accurate and in-depth interactions can be analyzed.

This study began by taking a look at a feasibility analysis that was recently performed on water foraging equipment. The equipment was for a Marine expeditionary unit (MEU) and its FOB. The previously developed model simulates a 30-day mission and how the use of foraging systems eased the burden of the resupply system. Using that model as a foundation, a series of experiments were performed to determine significant operational environment factors that affected the measure of effectiveness (MOE). After screening the significant factors a nearly orthogonal Latin hypercube (NOHL) was used to develop specific stressing configurations in order to determine the most stressful configurations influencing system performance. Analysis of the stressor configurations allowed for development of a “new” more robust system.

The most significant operational environment factors that affect the foraging system performance are platoon consumption rate, squad consumption rate, the amount of time available to forage, and the resupply frequency. Holding these stressful conditions constant the process was repeated to determine system requirements necessary to ensure mission success in the austere stressor scenarios. Requirement factors were screened and configurations were developed again by utilizing NOLH.

Foraging systems require significant improvement in order to function in the most extreme stressor scenarios. The platoon water purification system (PWPS) cannot support extended operations in an austere environment as the 30 gallon per hour capacity is insufficient. The minimum production capacity must be at least 58 gallons per hour to maintain mission sustainability in the extreme stressor scenario. This capacity ensures an acceptable threshold is maintained in the FOB for 28 days of the 30-day mission. The resulting requirements needed for the foraging system to be feasible in austere environments are significantly higher than current capabilities.

# **I. INTRODUCTION**

## **A. PURPOSE**

The aim of this study is to show how early modeling and simulation (M&S) efforts in the life cycle can be leveraged to develop better testing scenarios for system testing. It will produce a refinement of system requirements necessary to perform in the extreme stressor scenario.

## **B. BACKGROUND**

Systems engineering (SE) is an interdisciplinary collaborative approach to realize synthesize and develop real world systems that from early in a life cycle satisfies customer expectations (Walden 2015). It demands a value metric to quantify performance for any system that is developed. Testing and evaluation (T&E) is one of the latter parts of the system development phase of a system life cycle that can support or refute the operational value that a system offers to stakeholders and end users. Successful trials are critical to system development, and engineering management commonly espouses “on time and on budget.” Although many projects are applying systems engineering processes, many projects still overrun their budgets, fail to deliver in time, and at times, fail to deliver something really useful (Gianni, D’Ambrogio, and Tolk 2015). Many factors can go undocumented and untested due to unidentified interrelationships, missed opportunities for consideration, and simple unawareness of potential significance. These circumstances can result in a system that does not perform in severe conditions, yet manages to get an average passing score during evaluation. A well-developed stressor scenario is necessary to ensure that critical interactions are identified in order to address the stakeholder’s needs.

Sun Tzu said that wars are won and lost based on the availability of supplies. Current technological advancements are creating a stronger and more capable soldier while at the same time making a more energy-dependent warfighter. The important relationship between operational energy and material capability is critical to study. Increasing the desired capabilities corresponds to an increase demand for operational

energy. The National Research Council (2004, 4) concluded that “each new capability brings weight and space to be borne by the dismounted soldier.” This added weight and space not only adds to the soldier’s load, but also to the challenges of transporting and distributing required material, as well as straining the supply system at every level of the organization. By reducing the total loads on warfighters, their mobility and endurance can be increased. In early warfare, supplies were carried with the troops wherever they went. If something was needed, then it was attained through acquisition, via local population, or foraged from the wilderness. This process allowed troops to know how long they might go without outside sources for food or other items. As the complexity of militaries grew, energy and efforts required to sustain operations increased exponentially.

Rival forces, as well as our own forces are actively working to develop new technologies, systems, and tactics to be used to achieve dominance of the operational environment. The problems emerge when trying to balance urgency of operational need with the time and resources actually required for a functioning system. Under these conditions, there is no guarantee that the system, a new weapon or vehicle, will perform in a high stress scenario.

The means to generate operational energy is a significantly complex system of systems (SoS) that provides military functionality. The Department of Defense’s (DOD) operational energy demand has grown tremendously since fiscal year 2000 (Department of Defense [DOD] 2015). In its quest to become more energy independent, the Marine Corps is pursuing foraging technologies to allow units to operate longer without the need for constant resupply. New and old approaches are being explored to reduce stress on supply systems. Intermittent resupply as well as battlefield foraging have emerged as viable options for maintaining a fighting force. Various options are actively being pursued such as airdrop resupply where soldiers rendezvous with supplies that are dropped onto the battlefield either along their path or in close proximity.

The United States Marine Corps (USMC) is exploring the feasibility of solar and water foraging equipment for use on the battlefield. Locally sourcing materials and supplies that are needed to ensure operation success will reduce strain on supply lines, and can increase a unit’s ability to remain on station. Energy harvesting via emerging

solar and kinetic technologies is a return to the origins of warfighting in that groups manage their own provisions for the task at hand.

Water foraging has existed for some time in the military, but it was previously allocated on a larger scale and never on the front lines of combat. Large mobile purification vehicles were used to purify and then transport clean water to troops. The focus is now to supplement an individual soldier's water allocation with water found either by the soldier or by the soldier's squad. Acquiring the water closest to the user ensures individual needs can more easily and readily be met, minimizing the transportation leg of supply. Twelve percent of the United States Air Force's operational energy is used solely by tankers providing resupply of fuel (DOD 2015). Reducing the strain on the supply system provides energy for use in other areas.

These new and emerging foraging technologies must be able to stand up to the rigors of the combat environment. If not properly examined and tested under maximally severe conditions, they will have an increased chance of failure in an actual combat environment. It is imperative that proper testing be performed on these systems prior to implementation.

### **C. MODELING AND SIMULATION**

Modeling and simulation enables construction of systems and scenarios while simultaneously providing information on the robustness of a system. To understand the purpose of simulation, Clymer (2009, 55) said, "Simulation is required to design, analyze, evaluate, and optimize a complex system." As the complexity of systems have increased, the physical testing of every variable and setting can become impossibly expensive and tedious. The use of M&S has alleviated some of this burden. Time consuming and costly tests can be easily modeled and simulated for success. The statistical principle of the law of large numbers is intricately linked to M&S and provides useable results for analysis (Clymer 2009).

A new problem arises in that improper variable selection (i.e., eliminating significant factors) may yield results that do not coincide with real-world strenuous use of the system in a combat environment. To ensure proper development of testing scenarios it

is imperative that the interrelationships of critical variables are understood. Through experimentation, iteration, and simulation the interrelationships between factors can be scrutinized to determine the best combination for scenario development ensuring the maximal stressor scenario is developed.

#### **D. OBJECTIVES OF THE STUDY**

Current stressor scenarios for complex systems are inadequate. The Stryker mobile gun system and the Joint Air-to-Surface Standoff Missile (JASSM) are unfortunate examples of complex systems that were pushed through testing only to discover multiple design failures that were not adequately tested (DOD 2007). The objective of this study is to leverage a previously modeled system and its associated technologies to develop a more stressful testing scenario. It seeks to answer the following research questions:

- (1) How can early modeling and experimentation efforts in the system life cycle be leveraged to develop better stressor scenarios?
- (2) How can better stressor scenarios lead to more robust system designs?

#### **E. BENEFITS**

This study develops an approach to improve the development of stressor scenarios for operational testing and evaluation (OT&E) by leveraging previously applied M&S efforts in a system's life cycle. The resulting process can be further applied to other systems prior to their testing phase. Optimizing the testing scenarios will provide better resulting information about system performance and limitations. It provides for modification and development changes if needed to ensure mission capable systems are acquired for use. Many systems adopted by the military fail to perform under hardened conditions and create an undue and unsafe burden on the soldiers operating them. Optimal performance on all fronts is required to ensure that soldiers are equipped for the tasks they are assigned.

## **F. ORGANIZATION**

This study is organized in five chapters. Chapter I provides an introduction into the research topic of stressor scenario design. Chapter II is a literature review discussing the different technologies that have been fielded, failed systems, and the previously developed model being used for this study. Chapter III discusses and outlines the approach for the research and methodology employed. Chapter IV analyzes and presents the results obtained through the methodology in the previous chapter. Chapter V concludes with recommendations and the way forward based upon the results analyzed in Chapter IV.

THIS PAGE INTENTIONALLY LEFT BLANK

## **II. LITERATURE REVIEW**

### **A. OVERVIEW**

Self-sufficiency is a valuable characteristic in a unit or an individual. There have been times in the history of warfare that armies provided for their own needs throughout the conflict. Originally, pillaging and looting the defeated force was the normal means of reconstituting the force and its supplies. Hunting and gathering were always a part of continued subsistence throughout campaigns, but that aspect of war has diminished in the advent of modern warfare. With new and emerging technologies in the fields of renewable energy, there is a resurgence in attaining self-sufficiency on the battlefield.

Failed systems are a result of poor OT&E. The Stryker Mobile Gun System (MGS) entered testing with basic flaws identified by the operators (DOD 2007). The human interaction with the system seemed to be overlooked entirely in the development process and resulted in discoveries very late in the system's life cycle. The Joint Air-to-Surface Standoff Missile (JASSM) is another example of system issues discovered during OT&E (DOD 2001). If OT&E fails to catch issues, soldiers will encounter these issues on the battlefield.

Modeling and simulation is a field of study that has continued to evolve with the development of ever advancing computing systems. Within systems engineering, M&S is normally practiced in the testing phase as some tests are too costly to build prototypes and perform live tests. Some can be sufficiently assessed using a model. Often, M&S is used during early stages of development to assist in proof of concept or for operational concept development. Using design of experiments in a simulation to understand the underlying relationships between variables extends the value of M&S in a study.

### **B. PROBLEMS EMERGING FROM INADEQUATE TESTING**

Systems have become more and more complex as technology has advanced. More people are required to develop small portions of the larger system. When designed systems were less complex, one person could easily understand all of the applicable pieces and interactions. For example the first plane developed by the Wright brothers had

very few moving parts and was simple to control, whereas a modern fighter jet has countless interconnected systems. Current developments are far too complex. Current technologies incorporate multiple smaller systems into their operations and require far more understanding of intricacies than a single person is capable of having. As these SoS are continually developed, it is imperative that proper testing and understanding of relationships is determined. As Clymer noted, “Often the emergent behavior of a system is not predicted when the concept is proposed, and its occurrence is a surprise when the system concept is built” (2009, xxi).

The Stryker MGS was a recent development in the suite of military hardware that was designed to fill a gap between artillery and tanks. A large number of instruments and technology were placed into the Stryker MGS to ensure that it was capable of handling a variety of situations. One of the early failures discovered and discussed by the operators was the internal temperature (DOD 2007). Internal temperatures were in excess of 130 degrees and unsafe for operator health. Other major concerns included egress from within as well as machine gun weapon system placement (DOD 2007). These issues could have been simulated earlier than during live testing. Major portions of the cost of a given system are a direct result of decisions made during the early part of system design (Blanchard and Fabrycky 2011). This is an example of an emergent behavior of the system that was not modeled properly. Proper modeling of the system could have resulted in significant money and time saved, by not having to engineer a solution to these problems that should not have occurred.

The JASSM is another example of a system that had countless unforeseen design problems that could have been rectified earlier in the design process. After failures in 2001, it was declared that the models were validated using a small subset of target data, and that this caused the models to be immature and inadequate (DOD 2001). The immaturity of the models and their inability to describe real behavior accurately highlighted the need for the modeling effort to be closely monitored and validated with an appropriate number of data points (DOD 2001). It is readily apparent that proper data inclusion and simulation can increase the applicability and accuracy of developed models used for testing.

## **C. CURRENT FORAGING TECHNOLOGIES**

Various technologies are providing benefits to soldiers, squads, and all levels of military units. They can be subdivided into two main groups, mounted, and dismounted. Mounted gear is larger, indicating a significant weight problem and therefore must be attached to a mechanized platform for movement, whereas dismounted systems are easily transported by an individual or a squad as parts can be spread out among members of the unit. These systems are tested and have been modeled and studied in a previous simulation (Soh 2017), which will be used to leverage further M&S.

### **1. Examples of Dismounted Gear**

#### ***a. Individual Water Purification System***

Previous methods of purification required soldiers to add tablets and wait for some designated time to ensure viruses and bacteria were adequately removed. Individuals now have their own individual water purification (IWPS) system. This system does not require a power source mechanical motions, or a wait time because it is an inline filter. The IWPS connects directly to an individual's hydration pack. It can provide water filtration at a rate of about one quart per hour. This filter works to remove particulate matter as well as bacteria and viruses allowing soldiers to consume fresh water directly from the source without having to invest wait time. Its optimum output is 0.26 gallons per hour. Figure 1 shows the system connection with the hydration pack.



Figure 1. Platoon Water Purification System (PWPS).  
Source: Blanchard (2012).

***b. Squad Water Purification System***

The Mountain Safety Research (MSR) Guardian is a small handheld system designed to be utilized on the squad level by a single individual. It is shown in Figure 2. This purifier functions via mechanical operation of a hand pump drawing liquid from a desirable water source. A float attached to a hose draws the water from below the surface of the water and filters using a hollow fiber filter cartridge. It has a simple design to reduce maintenance requirements. It is a small lightweight system that has a maximum output capacity of four gallons per hour



Figure 2. Squad Water Purification System (SWPS).  
Source: MSR Guardian (2015).

## **2. Examples of Mounted Gear**

### ***a. Platoon Water Purification System***

The TECWAR MPRO 30HDX is a purification system designed for platoon level operations. It can provide water from fresh, brackish, and seawater sources which provides a versatile system capable of meeting demands from many different operational scenarios. It provides between 15 and 30 gallons of reverse osmosis (RO) water per hour and can run continuously for four hours using one power unit. This unit can also operate from the direct current (DC) power source on military vehicles. The system is pictured in Figure 3. It can produce 15 gallons per hour from a saltwater source and 30 gallons per hour from a fresh water source.



Figure 3. Platoon Water Purification System (PWPS).  
Source: TECWAR (2016).

#### **D. CURRENT WATER FORAGING MODEL**

In a feasibility analysis for the utility of foraging systems, Major Yuan Soh (2017) developed a water foraging simulation model. He utilized the aforementioned technologies to determine utility of implementation within a Marine expeditionary unit (MEU) conducting patrols from a forward operating base (FOB). The model is built in ExtendSim, a discrete event simulation modeling software. Soh (2017) studied the resiliency of the MEU resupply system against disruption and the ability of the FOB to continue operation. Results from sensitivity analysis of the model indicated that water foraging had a larger impact than energy foraging (Soh 2017). This model shows that under some disruptions in the operational scenario, military foraging improves the resiliency of the military unit. This simulation model provides an opportunity to examine to what degree that the recommended system in Soh's work can withstand high stress conditions. Discovering the operational settings that the recommended system fails, provides a way to identify improved system characteristics, thus a more robust system.

### **III. METHODOLOGY**

#### **A. OVERVIEW**

There is frequently not enough time or money to test a system in every operational situation that it may encounter. By testing a system in the most severe conditions, it forces creation of a robust system that is capable of success in a dire environment. Further studying the system of interest in a virtual environment allows development of a critical subset of test scenarios to provide more useful information about the system's performance. A significant time saver in this effort is leveraging previous models from system development. Examining and understanding the operational environment factors that create a difficult environment is the next step. Placing the system in more austere scenarios provides greater understanding about system issues.

Yuan Soh developed a simulation in ExtendSim that shows the resupply system of a MEU platoon performing distributed operations. Both a baseline system with no foraging and a foraging assisted model were developed and analyzed. Building on Soh's work, this study adds new features to the model to analyze the operational factors that influence the water foraging system. This thesis focuses on those operational energy systems that Soh created in the simulation model. Applying a traditional and customized design of experiments (DOE), we ran a series of experiments to explore the effects and influences of the various operational scenario factors.

A measure of effectiveness (MOE) defines how well a system contributes to mission success (Gianni 2015). Therefore, it is important to understand and precisely describe the mission of energy foraging in operational scenarios. For this study, MOEs provide an understanding for the degree that a foraging system assists a Marine unit in the ability to perform mission functions in an operational environment. Soh's model provides insight into how to develop relevant MOEs for this study.

## B. ENHANCING THE PREVIOUS FORAGING SIMULATION MODEL

### 1. Baseline Model

Soh's model is based on distributed operations of a MEU platoon. The FOB has a 30-day mission timeline and provides security in the region. It consists of rotating squads on three-day patrol operations with only one squad on mission at a time. This allows the non-patrolling squads to replenish supplies at the FOB and prepare for their next patrol. There are also deliveries of fuel and water to the FOB. The block diagram in Figure 4 illustrates a functional outline for how the resupply system works outside the system to consumption of resources within the system of interest.

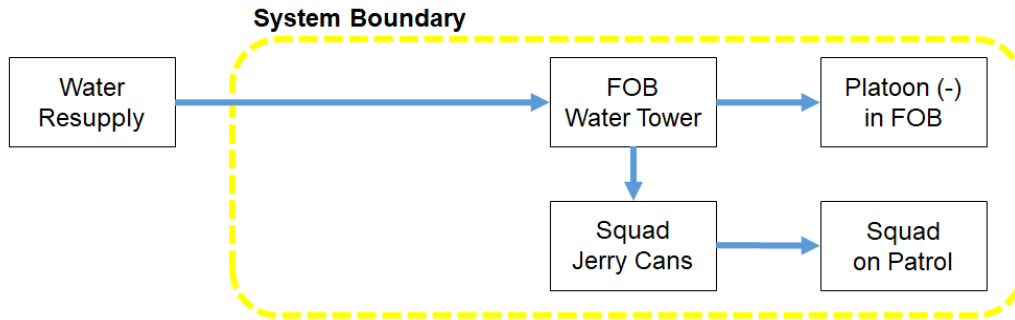

Figure 4. Simulation Model of Baseline System. Source: Soh (2017).

This simple diagram provides an idea of the internal activities, but the actual ExtendSim model is somewhat more complex. The complexities exist in the management of resources. For example, a squad on patrol does not receive inventory from the FOB while squads in the FOB receive proper allocation. The model represents how the squad on patrol may rely on foraging systems to sustain operations.

### 2. Foraging Model

The foraging scenario is built upon the baseline system with the integration of the foraging systems previously discussed in Chapter II. Various assumptions are made in reference to the geographic region of the scenario. These assumptions include sufficient daylight for solar collection as well as a local source of water available for purification

purposes. The assumptions of local sources are necessary since an area where these resources are not available would not be conducive to using a foraging strategy. The external source enters the closed system via the foraging technology employed (Figure 5). A PWPS is at the FOB purifying water from a local source and operated by one of the squads not on patrol. This provides a constant local source of replenishing water and reduces the need for resupply. Allocation of systems in the model is as follows: three SWPS per squad and one PWPS for the platoon.

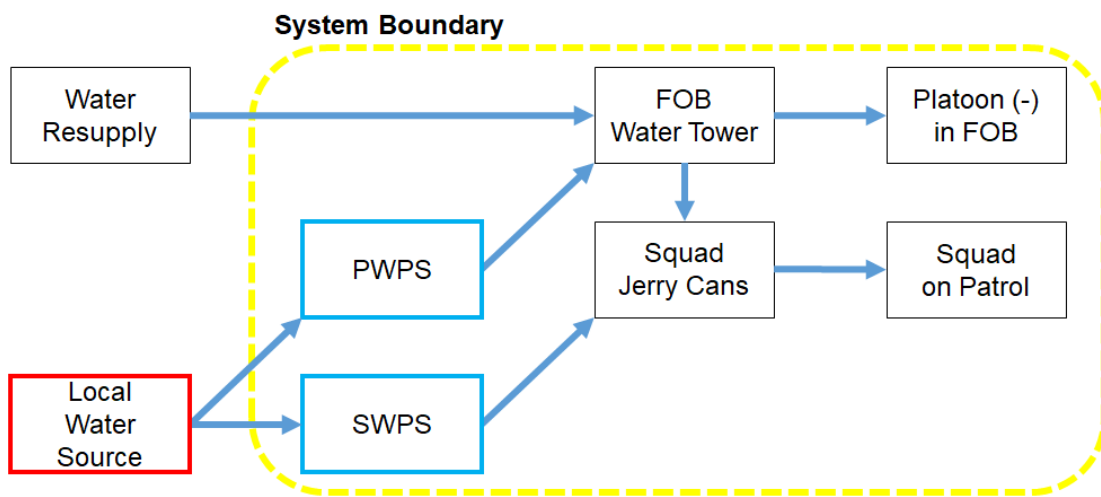

Figure 5. Simulation Model of Foraging System. Source: Soh (2017).

### 3. Disruptions

Soh investigated a few disruptions and analyzed the effects on the system. One disruption involves surge usage where consumption rates rise. Another disruption was one-time resupply interruption. Surge consumption provides a good look at a disruption to see how either increased physical activity will increase demand for water. Surge consumption of water is also affected by shifts in ambient temperature. These disruptions while valid, represent a small amount of possible interactions that could occur to affect the system. Establishing realistic models is an iterative process and continually requires further revision and refinement.

## C. LEVERAGING THE DEVELOPED MODEL

### 1. Overview

To develop high stress scenarios properly, the previously developed models must be understood, analyzed, and adapted. Soh’s analysis suggests ways to optimize the distribution of associated equipment to serve the needs of the MEU and associated personnel. This study will stress the optimized system to determine its breaking points, thereby identifying the conditions that challenge the system. These conditions are the foundation of stressor scenarios that the OT&E community can use.

### 2. Measure of Effectiveness

We define a set of MOEs that reflect the desired end state of the Marine unit (Table 1). The purpose of the FOB is to send squads on patrol at regular intervals. This thirty day scenario requires a daily patrol. A squad cannot start a patrol if there are insufficient resources and therefore need to invest time to fill reserves.

Table 1. MOEs and MOPs of the MEU Resupply System

MOE	Objective	MOP	Data Requirement	Goal
Operational Endurance	Maintain inventory with supplied and foraged resources to perform the mission	Reserve Index (RI)	Amount of Foraged Resources; Amount of Resupplied Resources; Amount of Consumed Resources	Larger is Better
		Preparation Index (PI)	Mission Duration; No. of Days Inventory > Reserve Threshold	Larger is Better

If the overall goal is to perform the mission objective without failure it is important to determine the factors that contribute to outcomes. Computing mission success consists of combining reserve index (RI) and preparation index (PI) data. The calculation of RI and PI are shown in Figure 6. The RI shows sustainability of the system. A low value indicates that more resources are being consumed than the amount of resources produced or supplied; it limits the duration the mission can continue. The PI is a positive indicator of whether or not enough supplies exist for the duration of operations.

If the PI is too low for an extended period of time, then the mission is unsustainable and results in failure to perform.

$$RI = \frac{\text{Foraged Resources} + \text{Resupplied Resources}}{\text{Consumed Resources}}$$

$$PI = \frac{\text{Mission Duration} - \text{Threshold Violations}}{\text{Mission Duration}}$$

Figure 6. Calculation of RI and PI

### 3. Factors

Factors contained in Table 2 are the basis for the experiments applied in the simulation.

Table 2. Operational Environment Factors

<b>Operational Factors</b>	<b>Represented by</b>	<b>Distribution</b>	<b>Reasoning</b>
Size of Water Delivery	Resupply Quantity	Uniform	Environmental Constraint, Mission Specific
Water Resupply Difficulty	Resupply Frequency	Triangular	Road Hostilities
FOB Capacity	FOB Capacity	Triangular	Possibility of damage or failure
Squad Inventory	Squad Inventory	Triangular	Possibility of damage or failure
Platoon Water Foraging Time	Platoon Manpower	Lognormal	More difficult to increase with other demands
Squad Water Foraging Time	Squad Manpower	Lognormal	More difficult to increase with other demands
Platoon Consumption Rate	Platoon Consumption Rate	Lognormal	Varies day to day
Squad Consumption Rate	Squad Consumption Rate	Lognormal	Varies day to day

Each of these factors represents uncontrollable variables of the operational scenario. They are aspects that the system has limited ability to control. The size of the water delivery and its frequency is limited because different operational areas and topographies provide a limitation on transportability to a FOB. Obviously, if deliveries are more difficult to achieve, then they will be conducted less frequently. Platoon inventory is limited in a similar way as the aforementioned topographical limitations. In an extreme heat environment more water will be consumed so a larger inventory should be on hand to ensure the needs are met. Squad inventory should also be modified for the environment based around the expected consumption rates. Individual member consumption rates in a high temperature environment will be much greater than if presented with a moderate climate. Foraging times are very important when considering the benefits of foraging. Depending upon the demands of the mission and operational environment, sufficient time for foraging may not be available, especially in the early stages developing a FOB.

#### **D. EXPERIMENTATION**

The factors listed in Table 2 indicate what are believed to be significant operational environment factors that need to be analyzed to create a more stressful test scenario. Initially determining which of the aforementioned factors or groups of factors are more significant than the others is necessary. First, a two-level, full factorial DOE will be performed on the factors using their high and low values. A summary of the high and low values is contained in Table 3. These values will yield 256 design points for initial analysis through the model.

Table 3. DOE Values

<b>Variable</b>	<b>Low</b>	<b>High</b>
Resupply Quantity	100 gallons	1000 gallons
Resupply Frequency	1 day	30 days
FOB Capacity	250 gallons	1500 gallons
Squad Inventory	30 gallons	75 gallons
Platoon Foraging Time	0.1 hours	6 hours
Squad Foraging Time	0.1 hours	3 hours
Platoon Consumption Rate	15 gallons/day	69 gallons/day
Squad Consumption Rate	7.5 gallons/day	31.5 gallons/day

Each of the 256 design points will be replicated 10 times in order to extract reliable data accounting for differences between runs in the model. Once results from the DOE runs are extracted, regression analysis on the results will show significant factors, as well as interrelationships between factors. This is used to screen any variables that do not have any significant effect on the system performance.

With the significant factors identified a Nearly Orthogonal Latin Hypercube (NOLH) is used to identify combinations of factor values that cause the system to fail. This approach is used, because it allows a robust sampling of the associated design space with minimal testing. With only two values per variable, there are 256 different combinations, but there are far more possibilities when taking into account every possible value for each variable. Unlike the 256 design point DOE, the NOLH process selects values from the continuous range of possibilities for the factor. A NOLH allows sampling of the enormous quantity of possibilities in a concise and efficient manner. Instead of randomly selecting configurations it controls and limits selection so that no configurations are identical and accurately represent the entire sample space.

After developing an NOLH sample set, it can be processed through the simulation to determine which system is the most stressful by using the MOE. Depending upon how factors compare with the current established MOPs, we may end up with different stressful scenarios. With the stress values identified, the process can be repeated with a design of experiments to determine non-environmental factors that need to be adjusted to ensure the system that is developed is reliable and capable to perform in even the most extreme of operational scenarios.

THIS PAGE INTENTIONALLY LEFT BLANK

## **IV. ANALYSIS**

### **A. OVERVIEW**

The primary MOE for this study is operational endurance, which evaluates the ability of the unit to maintain an appropriate level of inventory from supplied and foraged resources. This MOE is assessed via two MOPs: RI and PI. The RI relates to the overall quantity of collected inventory against the consumed inventory. The PI relates to the amount of time that the inventory levels at the FOB are above a specific threshold during the 30-day mission. Depending on objectives or focus, a stakeholder may choose to only consider one of the MOPs. The following analyses consider both MOPs.

### **B. REGRESSION ANALYSIS**

Regression analysis is applied to determine statistically significant factors in the experiment. Main factor and interaction terms in the analysis highlight factors in the operational environment that truly influence the behavior of the MOPs. The following sections discuss application of this technique on data collected from experiments using a full two-level factorial design; 256 design points with 10 replications.

#### **1. Reserve Index**

The initial DOE involves 256 design points to be processed through the model. Meaningful data such as foraged quantities by the squads and platoon as well as consumed quantities was extracted from the experimentation results to compute the MOPs. The RI is a ratio of the amount of water added to the system via resupply and foraging versus the amount consumed by the soldiers. Regression analysis was performed with the aforementioned factors against RI results. Statistics are shown in Figure 7.

Coefficients

Term	Coef	SE Coef	T-Value	P-Value	VIF
Constant	1.3713	0.0280	49.05	0.000	
Resupply Quantity	0.000077	0.000015	5.29	0.000	1.00
Resupply Frequency	-0.010072	0.000451	-22.36	0.000	1.00
FOB Capacity	0.000417	0.000010	39.88	0.000	1.00
Squad Inventory	-0.000197	0.000290	-0.68	0.497	1.00
Platoon Foraging Time	0.03196	0.00221	14.43	0.000	1.00
Squad Foraging Time	0.01228	0.00451	2.73	0.006	1.00
Platoon Consumption Rate	-0.007658	0.000242	-31.65	0.000	1.00
Squad Consumption Rate	-0.006345	0.000544	-11.66	0.000	1.00

Regression Equation

$$\begin{aligned}
 \text{RI} = & 1.3713 + 0.000077 \text{ Resupply Quantity} - 0.010072 \text{ Resupply Frequency} \\
 & + 0.000417 \text{ FOB Capacity} - 0.000197 \text{ Squad Inventory} + 0.03196 \text{ Platoon Foraging Time} \\
 & + 0.01228 \text{ Squad Foraging Time} - 0.007658 \text{ Platoon Consumption Rate} \\
 & - 0.006345 \text{ Squad Consumption Rate}
 \end{aligned}$$

Figure 7. Regression Analysis RI

At a 90% confidence level the Squad Inventory is not a significant factor. This is understood by examining both the T-Value and the P-Value associated with Squad Inventory. These values lead to conclusions in hypothesis testing. The null hypothesis for the regression analysis is that the factor, Squad Inventory, is zero, meaning that it has no influence on the value of RI. To reject the null hypothesis requires a P-Value less than 0.10. With a T-Value of -0.68 and a P-Value of 0.497 we cannot reject the null hypothesis; Squad Inventory has no significant effect on RI. The other variables contribute in some way and should remain in the next set of experiments.

Another aspect to examine is the two-way interaction plots for the variables. This helps identify significant relationships between factors. Figure 8 is the two-way interaction plot for the variables against RI.

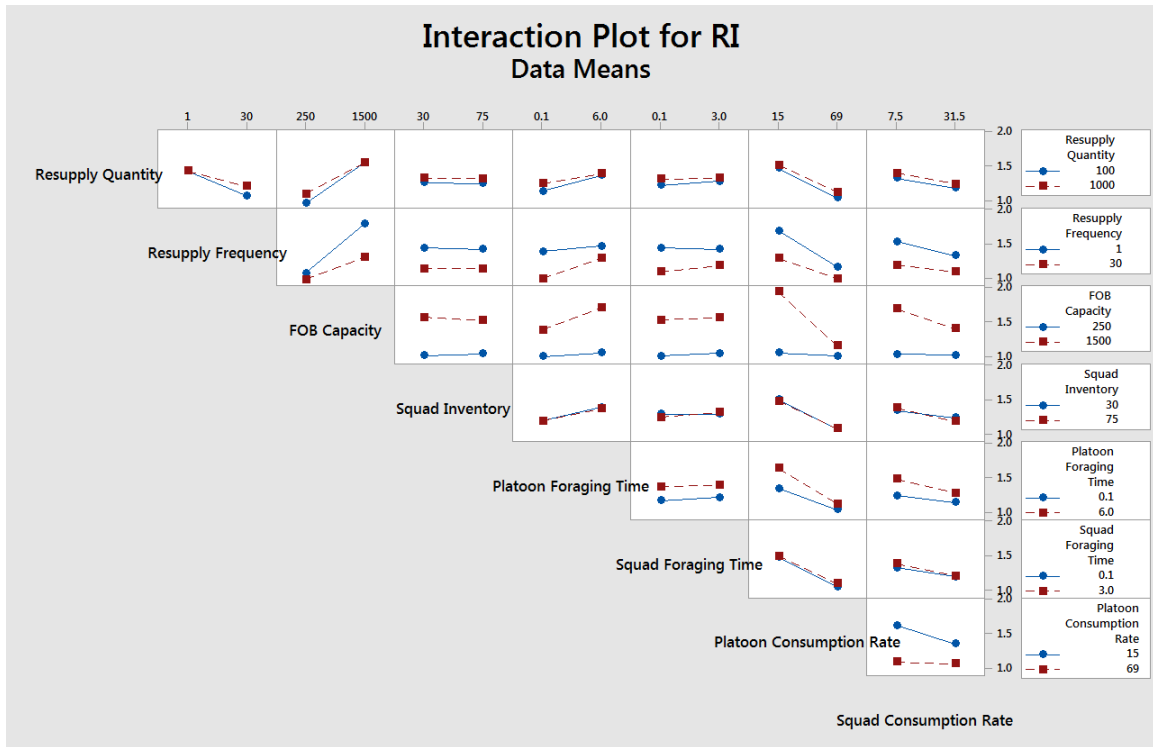

Figure 8. Two-Way Interaction Plot for RI

The interaction plot is read by looking for dissimilarities between the slopes of the lines for a significant interaction. For example Resupply Frequency has no relationship with Squad Inventory, while Squad Consumption Rate and Platoon Consumption Rate seem to have a significant relationship. This is expected as both platoon and squad consumption rates will bring down the overall resources. Visibly the FOB Capacity is affected by both Platoon and Squad Consumption rates. The regression analysis showed that Resupply Quantity was insignificant and the two-way interaction plot helps to verify that it does not have a significant influence on another variable. If it did, then screening the variable would not be possible due to its effect on another factor that influences system performance.

## 2. Preparation Index

The regression analysis of the factors against the PI was conducted in the same way as for RI. Figure 9 displays the output for the regression analysis.

Coefficients					
Term	Coef	SE Coef	T-Value	P-Value	VIF
Constant	1.1175	0.0144	77.72	0.000	
Resupply Quantity	-0.000000	0.000007	-0.03	0.975	1.00
Resupply Frequency	-0.013490	0.000232	-58.22	0.000	1.00
FOB Capacity	0.000001	0.000005	0.11	0.914	1.00
Squad Inventory	-0.000613	0.000149	-4.11	0.000	1.00
Platoon Foraging Time	0.03190	0.00114	28.01	0.000	1.00
Squad Foraging Time	0.01870	0.00232	8.07	0.000	1.00
Platoon Consumption Rate	-0.004423	0.000124	-35.55	0.000	1.00
Squad Consumption Rate	-0.000651	0.000280	-2.33	0.020	1.00

Regression Equation
$PI = 1.1175 - 0.000000 \text{ Resupply Quantity} - 0.013490 \text{ Resupply Frequency}$ $+ 0.000001 \text{ FOB Capacity} - 0.000613 \text{ Squad Inventory} + 0.03190 \text{ Platoon Foraging Time}$ $+ 0.01870 \text{ Squad Foraging Time} - 0.004423 \text{ Platoon Consumption Rate}$ $- 0.000651 \text{ Squad Consumption Rate}$

Figure 9. Regression Analysis PI

When the factors are compared against the PI there is a difference in which factors have an influence on PI than those that affect RI. The null hypothesis is that Resupply Quantity has no influence on PI. Similarly with RI this will be compared to a P-Value of 0.10. Resupply Quantity has a P-Value of 0.975; therefore, we cannot reject the null hypothesis. This is also true for FOB Capacity with a P-Value of 0.914. The other variables contribute in some way and will remain in the next set of experiments. Figure 10 shows the two-way interaction plot for the variables against PI.

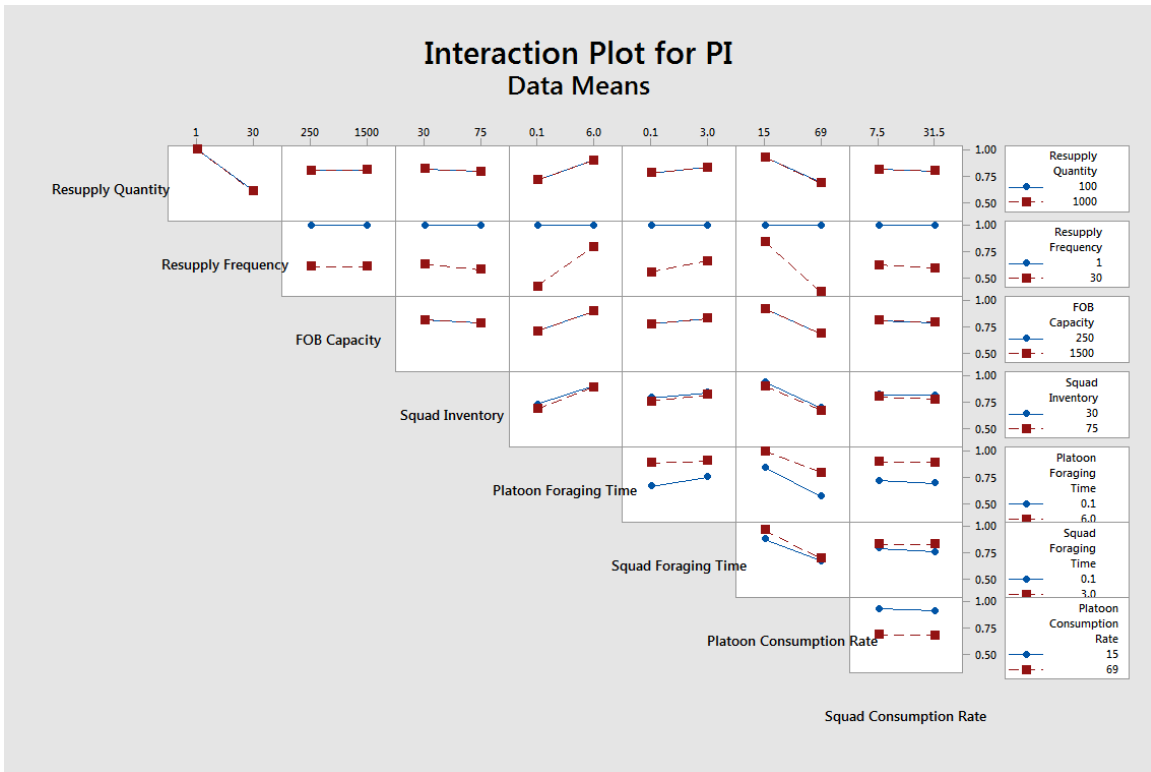

Figure 10. Two-Way Interaction Plot for PI

In terms of effects on RI, it seems as though Platoon Foraging Time and Consumption Rate have a stronger impact on PI if the Resupply frequency is low. This makes sense as the longer foraging time allows for the system to produce resources in order to prevent violating the threshold value. Similarly for their consumption rate, the higher consumption rate paired with the low resupply rate will have a significant effect on reaching the threshold. It also shows that more foraging time reduces the impact of higher consumption rates. This all holds true to what is expected.

### C. NEARLY ORTHOGONAL LATIN HYPERCUBE

The NOLH designs for both RI and PI were developed using an excel workbook from the Naval Postgraduate School simulation experiments and efficient designs (SEED) Center for Data Farming (Sanchez 2009). This NOLH is used to develop a DOE on the remaining significant factors that remain from the initial screening experiments.

## 1. Reserve Index

The NOLH for RI was developed using seven of the eight original factors. A simple Orthogonal Latin Hypercube (OLH) could be used due to the small amount of factors, but to get a better perspective of the sample space a larger NOLH was used. Figure 11 is an example for how an OLH would appear for RI.

low level	250	1	0.1	0.1	15	7.5
high level	1500	30	6	3	69	31.5
decimals	0	0	1	1	2	2
Configuration	Resupply Quantity	Resupply Frequency	Platoon Forage Time	Squad Forage Time	Platoon Consumption Rate	Squad Consumption Rate
1	641	30	4.9	1.2	28.5	30
2	328	8	5.3	1.7	15	15
3	406	14	0.5	0.8	48.75	27
4	484	19	1.9	3	45.38	10.5
5	1188	28	2.7	0.5	31.88	7.5
6	1500	10	2.3	2.5	18.38	25.5
7	1031	6	6	1	62.25	18
8	953	26	4.5	2.8	58.88	22.5
9	875	16	3.1	1.6	42	19.5
10	1109	1	1.2	1.9	55.5	9
11	1422	23	0.8	1.4	69	24
12	1344	17	5.6	2.3	35.25	12
13	1266	12	4.2	0.1	38.63	28.5
14	563	3	3.4	2.6	52.13	31.5
15	250	21	3.8	0.6	65.63	13.5
16	719	25	0.1	2.1	21.75	21
17	797	5	1.6	0.3	25.13	16.5

Figure 11. OLH Example

In the OLH configuration, 17 different factor combinations are developed representing a balanced sampling of the entire design space using minimal configurations. For a more in-depth experiment of the design space a larger NOLH was used. The resulting 257 design represents 257 operational or stressor configurations to apply in the model. The resulting RI scores and associated stressor configurations are in Table 4. Recall that RI scores below 1.0 indicate that the consumption is greater than the resupply amounts.

Table 4. Excerpt of Results from NOLH RI Stressor Configurations

Stressor Configuration	Resupply Amount	Resupply FRQ	FOB Capacity	PLT Forage	SQD Forage	PLT Consumption	SQD Consumption	RI
180	1485	11	1202	0.2	0.3	62.04	30.56	0.73
245	1080	16	1319	2.3	0.2	64.57	23.06	0.75
247	997	19	812	3.1	0.2	59.51	23.16	0.75
79	348	16	426	0.1	1.2	46.85	21	0.75
105	680	22	1456	4	0.1	67.95	14.44	0.76
9	343	16	1412	3.8	1.2	57.4	25.22	0.76

The stressor configurations were organized by ranking the RI scores. Stressor Configuration 180 has the lowest RI score, followed closely by Configuration 245. For RI, these value combinations are the most stressful on the foraging system. If RI is deemed to be the more appropriate MOP by the stakeholder, these are the stressors that should be used to try the system for acceptance.

## 2. Preparation Index

Similar to the RI, the PI NOLH was developed using the same NOLH workbook. The difference in design is the factors that were used. Resupply Amount and FOB Capacity were not included in this set of experiments. Values for those factors are held constant in the experiments. The stressor configurations for PI are summarized in Table 5.

Table 5. Excerpt of Results from NOLH PI Stressor Configurations

Stressor Configuration	Resupply Frequency	SQD Inventory	PLT Forage	SQD Forage	PLT Consumption	SQD consumption	PI
179	28	50	0.3	2.6	53.81	9.38	0.37
91	25	56	0.4	0.6	58.66	16.97	0.40
229	18	51	0.6	0.2	67.31	25.41	0.43
59	23	72	0.2	1.2	38.84	27.38	0.53
247	19	53	0.4	2.5	50.23	28.22	0.53

Configuration 179 has the lowest PI score. Recall that a PI score less than 1.0 indicates the percentage of time of a 30-day operation that the inventory amount is less than the required threshold. A long period of time between resupplies puts more need on

the unit to forage its own resources. Similarly, limited time for foraging activities coupled with high consumption rates ensures a large amount of stress on the system. If PI is determined to be a more appropriate measure by the stakeholder then, Configuration 179 values should be used to stress the system.

#### **D. NEW REQUIREMENTS**

In the initial problem space Soh (2017) examined the feasibility of using foraging systems to address the need of reducing operational resources to deployed Marines. This study was a result of a need to determine the utility of an existing system. Soh's work was based on averaging results that included some of the minor disruptions discussed earlier in this thesis. This study extends Soh's work to examine system configurations that are on average successful by determining system performance under maximally austere conditions. Results would guide operational test and evaluation agencies for adequately stressing the system prior to acceptance.

Under these optimally stressed scenarios, new requirements of a system can be identified. It is the new system requirement that should be developed and considered for acceptance. We use the same process to examine system attributes while holding the optimal stressor scenario factor values constant. A two-level factorial DOE on the system's attributes can be used to screen which prospective system requirement factors are most important. They, in turn, are applied to further refine the NOLH design to identify system requirements that will result in the OE system achieving success in the extreme scenario.

Table 6 outlines the system factors in the model for evaluation. These factors relate to the specifications and abilities of the foraging system that is being introduced. Results at the end of the analysis will indicate the appropriate abilities of the system that should be implemented it into the most taxing scenario.

Table 6. System Factors

<b>Factors</b>
Quantity of PWPS
Quantity of SWPS
PWPS Output Capacity
SWPS output Capacity
PWPS Efficiency
SWPS Efficiency

These factors result in a two-level full factorial experimental design ( $2^6$ ) with 20 replications that result in 1280 simulation runs. This DOE was placed in both Stressor Configuration 180 and Stressor Configuration 179 models and subsequently analyzed.

### 1. Stressor Configuration 180

Since stressor configuration 180 specifically stresses RI, the RI value will be used to analyze the resulting new system requirements. The same process for screening significant factors from the design space is used to generate new requirements. Figure 12 shows the regression analysis for Stressor Configuration 180. Figure 13 is the two-way interaction plot for RI. The results held to a 90% confidence level show that both PWPS efficiency and SWPS efficiency are not significant factors.

#### Coefficients

Term	Coef	SE Coef	T-Value	P-Value	VIF
Constant	1.0205	0.0156	65.29	0.000	
Number PWPS	0.013295	0.000562	23.65	0.000	1.00
Number SWPS	0.011898	0.000562	21.17	0.000	1.00
PWPS Capacity	0.000910	0.000040	22.66	0.000	1.00
SWPS Capacity	0.003667	0.000176	20.88	0.000	1.00
PWPS Efficiency	0.0049	0.0141	0.35	0.726	1.00
SWPS Efficiency	0.00741	0.00937	0.79	0.429	1.00

#### Regression Equation

$$RI = 1.0205 + 0.013295 \text{ Number PWPS} + 0.011898 \text{ Number SWPS} + 0.000910 \text{ PWPS Capacity} + 0.003667 \text{ SWPS Capacity} + 0.0049 \text{ PWPS Efficiency} + 0.00741 \text{ SWPS Efficiency}$$

Figure 12. Configuration 180 Regression Analysis on System Requirements for RI

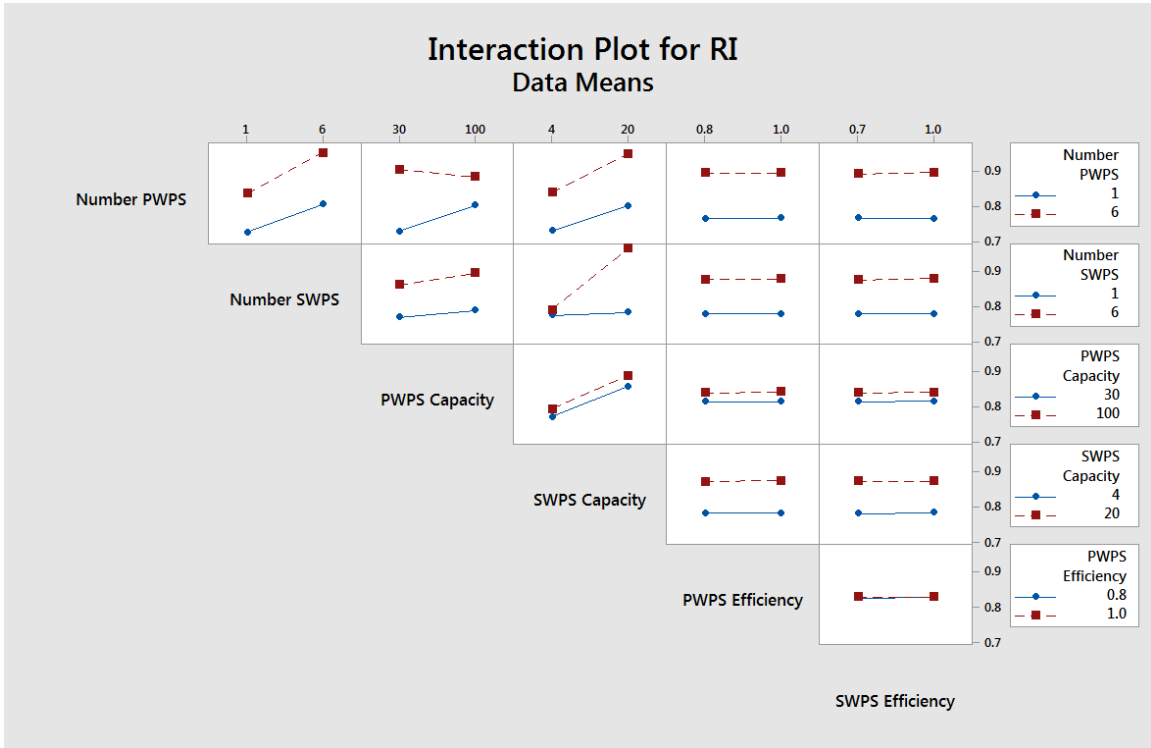

Figure 13. Configuration 180 Two-Way Comparison RI

The two-way interaction plots show that neither SWPS nor PWPS efficiencies have significant interactions with any other factors, confirming that these main factors should not be part of the next set of experiments to refine system requirements. Stressor Configuration 180 establishes four factors of interest for another NOLH of requirement configurations. Processing the NOLH configurations through the model using Stressor configuration 180 yields the results in Table 7. Requirement Configuration 209 had the highest RI score for Stressor Configuration 180. This “new system” configuration will succeed in the most severe conditions that this study has constructed for RI.

Table 7. New System Configuration for Success in RI under Stressor Scenario 180

Requirement Configuration	Number PWPS	Number SWPS	PWPS Capacity	SWPS Capacity	RI
209	4	6	75	17.6	1.057
255	5	6	41	19.3	1.049
57	3	5	83	20	1.041
183	6	5	60	19.8	1.039
239	5	6	53	17.2	1.039

## 2. Stressor Configuration 179

For evaluation of new system requirements under Stressor Configuration 179, we use PI. The initial factors found in Table 6 were screened against the PI measurement. The Regression analysis is shown in Figure 14 and the two-way interaction plot in Figure 15.

### Coefficients

Term	Coef	SE Coef	T-Value	P-Value	VIF
Constant	0.1959	0.0174	11.28	0.000	
Number PWPS	0.099917	0.000624	160.06	0.000	1.00
Number SWPS	0.000438	0.000624	0.70	0.484	1.00
PWPS Capacity	0.001418	0.000045	31.81	0.000	1.00
SWPS Capacity	0.000189	0.000195	0.97	0.333	1.00
PWPS Efficiency	0.0042	0.0156	0.27	0.790	1.00
SWPS Efficiency	0.0014	0.0104	0.13	0.894	1.00

### Regression Equation

$$PI = 0.1959 + 0.099917 \text{ Number PWPS} + 0.000438 \text{ Number SWPS} + 0.001418 \text{ PWPS Capacity} + 0.000189 \text{ SWPS Capacity} + 0.0042 \text{ PWPS Efficiency} + 0.0014 \text{ SWPS Efficiency}$$

Figure 14. Configuration 179 Regression for PI

The regression analysis on Stressor Configuration 179 reveals that only the Number of PWPS and the Capacity of the PWPS are relevant factors.

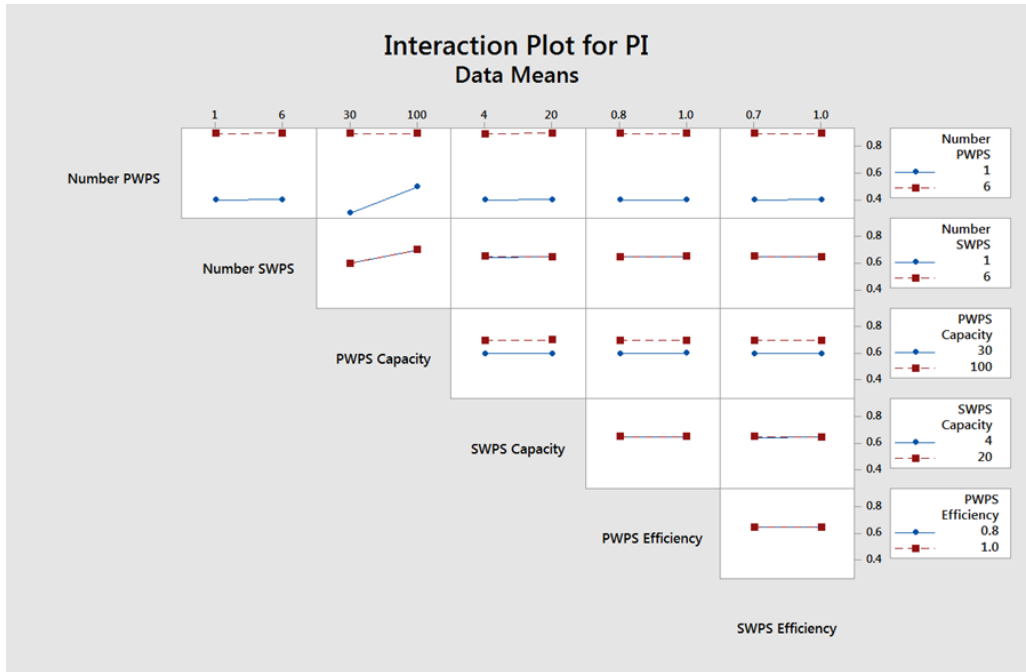

Figure 15. Configuration 179 Two-way comparison PI

Figure 15 shows that the other four factors have no significant interactions with PWPS number or PWPS capacity. This reinforces the lack of influence of the other factors on PI. Developing the sample design space with only two factors is conducted using the same NOLH workbook with the appropriate factors. The summarized System Requirement Configuration results are found in Table 8.

Table 8. New System Configuration for Improved PI under Stressor Configuration 179

Requirement Configuration	Number PWPS	PWPS Capacity	PI
4	3	58	0.93
5	3	73	0.93
21	3	85	0.93
25	2	86	0.93
34	3	83	0.93

Table 8 shows that none of the system configurations could achieve success against the severe operational condition in which it was placed. However, a PI score of

0.93 indicates that only two days occurred where the threshold value was violated. In the previous system configuration there was approximately one week in which inventory levels were insufficient for the unit to perform its patrol missions.

### 3. Resulting Foraging Designs

Table 9 shows both resulting new system designs as a result of stressor scenarios. These new designs should lead engineers to revisit system requirements.

Table 9. Stressor Scenario-Based Requirements

Stressor Configuration	Requirement Configuration	Number of PWPS	Number of SWPS	PWPS Capacity	SWPS Capacity
180 RI	209 RI	4	6	75 gallons/hour	17.6 gallons/hour
179 PI	4 PI	3	3	58 gallons/hour	4 gallons/hour

Each MOP resulted in a slightly different system. The system developed by focusing on PI requires a PWPS that is capable of producing at least 58 gallons per hour which is currently 28 gallons more per hour than the current PWPS system provides when a freshwater source is available. Stressor Configuration 180 was based around the RI, the amount of resources that can be collected on a given day and requires PWPS Capacity to be 75 gallons per hour and SWPS Capacity to nearly 18 gallons per hour, while increasing the number of PWPS and SWPS. System requirements under stressor scenarios for RI dominate the system requirements under stressor scenarios for PI.

Comparing Soh's (2017) foraging equipment allocation to those developed in the Stressor Configurations indicates increasing the number of PWPS. Soh's configuration called for two PWPS foraging for at least 36 minutes a day. That specific design worked to supplement the resupply requirement and in the case of a minor disruption, provide some resilience and recovery for the FOB. These stressor-scenario designed systems will easily provide for the needs of the FOB in calm and undisrupted times, but will also perform successfully in much more severe circumstances. The previous design could not function during an extended stressor scenario and ensure mission completion.

THIS PAGE INTENTIONALLY LEFT BLANK

## **V. CONCLUSIONS AND RECOMMENDATIONS**

The study of the operational scenarios as a driving factor to develop more robust systems provides some important insights in general, and specifically for the OE related technologies discussed in this thesis. Modeling and simulation, coupled with experimentation and analysis presents statistical rigor to guide scenario development in preparing for acceptance testing. The results are useful in addressing the research objectives in this thesis.

### **A. CONCLUSIONS**

Numeric findings are important evidence in this study. More notably, interpretations of these results have an impact on defining system requirements, design, and development considerations, which guide engineers in producing more useful systems. In general, we can conclude that better test scenarios can be found through sequential computer experimentation on operational scenario factors that have been applied in the early stages of system design; in this feasibility analysis, that work from Soh (2017).

The study focused on leveraging a designed model that has been used to model and understand the behavior and needs of a water foraging system for use by a military unit. The results created multiple unique stressor scenarios to choose from. Depending upon cost concerns, specific test might be desired over another. The developed Stressor Configurations provide key insight into how the operational environment factors relate to the system.

Better stressor scenarios lead to more robust system designs. The previous system design was tested against specific challenges of limited duration. Those challenges were limited in scope. Specifically, the rise in consumption rate for Soh's study was testing resiliency of the resupply system to recover. Recommendations made by Soh (2017) were based upon the system's performance through the trials. That system was the baseline for this thesis. The baseline system failed to successfully meet the needs of the unit in the heightened stress environment.

The robust system comes from developing one capable of handling the extreme tests for a longer duration. The designs created using the higher stressed consumption rates presented in this thesis are purposely built to function under sustained extreme demands. When placed in a normal scenario, they are more than capable of providing success for short term extreme conditions.

Time is one of the most critical resources that a soldier has on the battlefield. It is even more apparent in a hostile area with combatants. The amount of time available is not easily modeled as tactical decisions must be made. In order to reduce the amount of time needed to perform foraging tasks, more automation is required. The PWPS is relatively independent from human interaction, but the SWPS depends upon it.

High stress situations that prevent or significantly limit the time available for foraging operations are very difficult for any configuration to perform in. This prevents the system from being used throughout the force, but presents itself as a tactical decision for the right scenarios.

One of the most stressful conditions in the stressor configurations is the resupply frequency. As the capacities of the foraging systems improve, the possibility of FOBs providing for their own needs without external resupply is greatly increased. Water independent units would have a greater reach and more versatility in the field.

## **B. RECOMMENDATIONS**

The process described in this thesis for creating a more robust system design should be adopted by operational test and evaluation agencies. The original system was found to be optimal under non-severe conditions. Based upon the results of the analysis under severe operational conditions, it is recommended that more investigation and analysis be conducted. The model as it is currently constructed can be expanded to incorporate the smaller units of time and individual members of the squad and platoon. This will allow for varying consumption rates throughout the day to more adequately reflect real-world situations. By expanding upon the model, more valuable and more precise estimations of feasibility can be obtained.

OE-related systems must work in tandem at different levels of a military organization. The scenario significantly stressed the allowed time that the individual unit could forage. The results of the analysis under these extreme scenarios coupled with the current capabilities of the foraging technologies it is recommended that this system not be used in any scenario where active combat against the FOB is likely. The current capabilities are insufficient to provide for the needs when significantly limiting situations are possible. The OE foraging systems are recommended for use in non-combat zone operations as the system alleviates some of the burden on the resupply system.

THIS PAGE INTENTIONALLY LEFT BLANK

## LIST OF REFERENCES

- Blanchard, Amber. 2017. "New IWPS II Individual Water Purification System Block II for U.S. Marines 12301175." Army Recognition. January 23, 2017. [http://www.armyrecognition.com/weapons\\_defence\\_industry\\_military\\_technology\\_uk/new\\_iwps\\_ii\\_individual\\_water\\_purification\\_system\\_block\\_ii\\_for\\_u.s.\\_marines\\_12301175.html](http://www.armyrecognition.com/weapons_defence_industry_military_technology_uk/new_iwps_ii_individual_water_purification_system_block_ii_for_u.s._marines_12301175.html).
- Blanchard, Benjamin S., and Wolter J. Fabrycky. 2011. *Systems Engineering and Analysis*. 5th ed. Upper Saddle River, NJ: Prentice Hall.
- Clymer, John R. 2009. *Simulation-Based Engineering of Complex Systems*. Hoboken, NJ: John Wiley & Sons.
- Department of Defense. Office of the Assistant Secretary of Defense for Energy, Installations and Environment. "2016 Operational Energy Strategy." Accessed May 13, 2016. <https://www.acq.osd.mil/eie/Downloads/OE/2016%20DoD%20Operational%20Energy%20Strategy%20WEBc.pdf>
- Department of Defense, Department of Test and Evaluation. "Stryker – Mobile Gun System." Accessed June 1, 2016. <http://www.dote.osd.mil/pub/reports/FY2007/pdf/army/2007strykermgs.pdf>.
- Department of Defense, Department of Test and Evaluation. "Joint Air-to-Surface Standoff Missile." Accessed June 1, 2016. <http://www.dote.osd.mil/pub/reports/FY2001/pdf/af/01jassm.pdf>
- Gianni, Daniele, Andrea D'Ambrogio, Andreas Tolk, eds. 2015. *Modeling and Simulation-Based Systems Engineering Handbook*. Boca Raton, FL: CRC Press.
- Loper, Margaret L. ed. 2015. *Modeling and Simulation in the Systems Engineering Life Cycle: Core Concepts and Accompanying Lectures*. London: Springer-Verlag.
- MSR Guardian. 2015. "Guardian Purifier: The World's Most Advanced Backcountry Purifier." Accessed September 5, 2017. <https://www.msrgear.com/guardian-purifier>.
- National Research Council, 2004. *Meeting the Energy Needs of Future Warriors*. Washington, DC: The National Academies Press.
- Soh, Yuan Wei. 2017. "Engineering resilience into the Marine Expeditionary Units resupply system through military foraging." Master's thesis, Naval Postgraduate School. <http://hdl.handle.net/10945/56179>.

TECWAR. 2016. "Military Portable Reverse Osmosis Heavy Duty Extreme 30 and 60 GPH Portable Water Purification Systems." Accessed September 5, 2017. <http://tacticalwater.com/MPRO.html>.

Walden, David D., Garry Roedler, Kevin Forsberg, Douglas Hamelin, and Thomas Shortell, eds. 2015. *Systems Engineering Handbook: A Guide for System Life Cycle Processes and Activities*. Hoboken: New Jersey: Wiley and Sons.

## **INITIAL DISTRIBUTION LIST**

1. Defense Technical Information Center  
Ft. Belvoir, Virginia
2. Dudley Knox Library  
Naval Postgraduate School  
Monterey, California