



**Total Force Integration: A look at the Integrated Wing Pilot Program  
at Seymour-Johnson AFB, NC**

GRADUATE RESEARCH PAPER

June 2017

Jason O. Harris, Major, USAF

AFIT-ENS-MS-17-J-030

**DEPARTMENT OF THE AIR FORCE  
AIR UNIVERSITY**

**AIR FORCE INSTITUTE OF TECHNOLOGY**

---

Wright-Patterson Air Force Base, Ohio

DISTRIBUTION STATEMENT A.  
APPROVED FOR PUBLIC RELEASE; DISTRIBUTION UNLIMITED.

The views expressed in this Graduate Research Paper are those of the author and do not reflect the official policy or position of the United States Air Force, Department of Defense, or the United States Government.

AFIT-ENS-MS-17-J-030

**Total Force Integration: A look at the Integrated Wing Pilot Program  
at Seymour-Johnson AFB, NC**

**GRADUATE RESEARCH PAPER**

Presented to the Faculty

Department of Operational Sciences

Graduate School of Engineering and Management

Air Force Institute of Technology

Air University

Air Education and Training Command

In Partial Fulfillment of the Requirements for the  
Degree of Master of Science in Operations Management

Jason O. Harris,

Major, USAF

June 2017

**DISTRIBUTION STATEMENT A.**  
APPROVED FOR PUBLIC RELEASE; DISTRIBUTION UNLIMITED.

AFIT-ENS-MS-17-J-030

**Total Force Integration: A look at the Integrated Wing Pilot Program  
at Seymour-Johnson AFB, NC**

Jason O. Harris, Major,

USAF

Committee Membership:

Lt Col Jason R. Anderson, PhD

Chair

### **Abstract**

This graduate research paper takes an exploratory examination of the Total Force Integration by way of the Integrated Wing (I-Wing) Pilot Program at Seymour-Johnson AFB, NC. The exploratory research examines the challenges and possible solutions to ARC and USAF ability to plan, generate, and execute missions in a total force environment. More specifically, this paper takes an exploratory look at the National Commission on the Structure of the Air Force (NCSAF), and the new I-Wing Pilot Program recently stood up at Seymour-Johnson Air Force Base, NC. This new structure, a result of the 2014 NCSAF and guidance from the Chief of Staff of the Air Force and the Secretary of the Air Force, has the potential to create opportunities for synergistic gains and efficiencies among the Air Force components. This research will explore areas and opportunities for synergy with an emphasis on the administration (ADCON) and Operational (OPCON) challenges.

## **Acknowledgments**

I would like to express my sincere appreciation and gratitude to my research advisor, Lt Col Jason R. Anderson, for his wisdom, guidance, support and patience throughout the research and production of this GRP. I would also like to thank my research sponsor and mentor, Maj Gen James P. Scanlan, for the mentorship, guidance and direction provided throughout the GRP process.

I would also like to thank the members of the 916<sup>th</sup> ARW, Active and Reserve Component members that assisted in gathering data for this research. Additionally, I would like to thank members of the TF-C office for their contributions to this research.

Jason O. Harris

## Table of Contents

Abstract.....	iv
Acknowledgments.....	1
Table of Contents .....	2
List of Figures .....	5
List of Tables .....	6
I. Introduction .....	7
Background and General Issue .....	7
Research Objectives/Questions/Hypotheses .....	9
Research Focus .....	10
Problem Statement.....	11
Investigative Questions.....	11
Methodology.....	12
Assumptions/Limitations.....	12
Implications .....	13
II. Literature Review.....	15
Chapter Overview.....	15
Bureaucratic Management Theory .....	15
National Commission on the Structure of the Air Force, 2014 .....	17

Association Types.....	23
Program Guidance Letter L16-01 (PGL L16-01).....	24
UCMJ Authority.....	27
Unity of Command.....	28
AFI 90-1001.....	30
ADCON Overview.....	30
OPCON Overview.....	31
Operational Direction (OPDIR).....	31
III. Methodology.....	33
Chapter Overview.....	33
Research Design.....	33
Data Collection Methods.....	35
Interview Participants.....	35
Interview Format and Medium.....	36
Survey Description & Protocols.....	36
Data Collection.....	38
Data Analysis.....	38
Summary.....	<del>39</del> 38
IV. Analysis and Results.....	40
Chapter Overview.....	40
Unity of Command.....	40
Notable Considerations.....	50

Summary.....	52
V. Conclusions and Recommendations.....	55
Chapter Overview.....	55
Conclusions of Research and Recommendations for Action .....	55
Significance of Research .....	57
Recommendations for Future Research.....	57
Summary.....	58
Appendix A. Quad Chart.....	59
Appendix B. Questionnaire.....	60
Bibliography .....	62

## **List of Figures**

Figure 1: Integrated Wing Leadership Concept from NCSAF.....	22
Figure 2: Active Association Structure .....	25
Figure 3: I-Wing Structure with Dual-Hat Commander.....	26

## **List of Tables**

Table 1. Interview Protocol Refinement (IPR) Method (Castillo-Montoya, 2016) .....37

-

# **Total Force Integration: A look at the Integrated Wing Pilot Program at Seymour-Johnson AFB, NC**

## **I. Introduction**

### **Background and General Issue**

In March 1968 the Air Force established the first Air Force Reserve associate program. In August of 1968 the first flight by an all reserve crew, flying a C-141, departed Norton Air Force Base, California destined for a mission to Southwest Asia in support of combat operations (Cantwell, 1997). Forty-nine years later the Air Force Reserve Command (AFRC) associate program, different in some aspects than in 1968, continues to exist, providing our nation with a reserve force ready to heed the call of our nation and help protect her freedom. Over time, the US Air Force (USAF) has sought to better integrate the different service components into a more cohesive, interchangeable, structured organization. A common term used to illustrate this interchangeable force structure is Total Force (TF) and Total Force Integration (TFI). So much so has this idea become prevalent and sought after in the last few years that a Total Force Continuum (TF-C) office has been set up within the USAF Headquarters, with oversight from three Brigadier Generals, one from the Active Duty (AD), Air National Guard (ANG) and AFRC respectively.

The National Commission on the Structure of the Air Force (NCSAF/The Commission), established by congressional mandate in 2013, was created to address challenges experienced by the Air Force with meeting its national security mission with its then current inventory of resources and manning (United States, National Commission on

the Structure of the Air Force, 2014). The Commission released its findings to Congress in January of 2014. The Commission presented forty-two (42) recommendations for changes and realignments to the structure of the Air Force. Reviewing the report reveals that the Commission believed increased force integration is necessary as the Air Force moves forward. The Commission also believed that the Reserve Components (RC) contained massive amounts of untapped potential and the way to unlock this potential is to change the structure and how we integrate our Reserve Components. The Air Force agreed on all but one of the forty-two recommendations. The one recommendation that was not supported by the Air Force, due to legal constraints, statutes and organizational requirements is the recommendation number five that recommended dissolving the Air Force Reserve Command.

In response to the growing challenges with the integration and structure of the Air Force, the Chief of Staff of the Air Force and the Secretary of the Air Force established the Total Force Task Force in January of 2013. This Task Force was staffed under Headquarters Air Force with the intent to find and exploit ways to better integrate the three components. In addition, the Air Force published program guidance that would stand up a new Integrated Wing (I-Wing) as a test bed for integration. And most recently, in 2016, the Air Force completed a rewrite of an important document necessary for and guidance for total force integration, Air Force Instruction 90-1001 (U.S. Air Force, 2017).

The I-Wing concept, or as it is laid out, the I-Wing Pilot Program, is a direct result and an evolution of analysis of The Commission report delivered in 2014. The I-Wing is designed to leverage home-station or in-garrison force structure for the Air Force that will enable the service to better leverage the service's strengths of each of its components. At the same time, the I-Wing is designed to balance capacity, capability, and readiness of all

components of the Air Force. The I-Wing model is designed with an intent to functionally integrate like structured organizations as well as create a nexus for chain of commands that will enable the Air Force to more effectively and efficiently meet the evolving mission requirements levied on the service. As stated in the Program Guidance Letter (PGL), the analysis suggests that in our fiscally constrained environment, combined with evolving global threats, this new Total Force construct will aid in delivering efficient and effective mission capacity and capability with the best value for the Air Force and for our nation (HQ USAF, 2016).

As the I-Wing Pilot Program is rolled out at Seymour-Johnson Air Force Base, it will be imperative that the Air Force evaluate the model from all aspects to gather information on chances for success or failure and the ability to roll this program out to other bases. The success of the I-Wing concept, in addition to the lessons learned, will enable the Air Force to replicate this model at other installations. Replication of this model, should it prove to be successful, will enable the Air Force to work towards compliance with The Commission and exploit synergies and efficiencies in the system. This will allow the Air Force to continue having the ability to project air, space and cyber power globally.

### **Research Objectives/Questions/Hypotheses**

The goal of this research is to explore the change from an Active Association Unit to a new and recently established Integrated Wing (I-Wing) Pilot Program at Seymour-Johnson Air Force Base, North Carolina. Another objective of this research is to explore the I-Wing Pilot Program and assess the challenges, positive and negative, along with the outcomes thus far. This assessment, completed in an exploratory manner, will enable the researcher to provide feedback to interested parties that might be helpful to provide

adjustments and corrections to the program while in its pilot stage, providing the program a better chance for success. This research attempts to answer the following questions through exploratory research and thematic analysis utilizing Max Weber's Bureaucratic Management Theory:

1. Has the I-Wing Pilot Program progressed toward the stated goals thus far?
2. Is the I-Wing Pilot Program on track to meet stated objective timelines set forth in the Program Guidance Letter to move from Phase I through Phase II and subsequently Phase III?
3. What administration challenges exist or are newly created?
4. Is the I-Wing Pilot Program and the Total Force Continuum office able to overcome the administrative challenges with the operating structure set forth in the Program Guidance Letter?

The hypothesis is that the I-Wing Pilot Program, in its current Dual Hat Commander structure, with parallel Active and Reserve Component organizations, will be challenging to manage and transition to a true and effective single, integrated chain of command. Additionally, the I-Wing, based on the Program Guidance Letter, will be unable to meet set objectives and timelines. Finally, there are issues regarding administrative and legal constraints that will constrain the organization from meeting its full potential.

### **Research Focus**

This research will focus on the Integrated Wing (I-Wing) at Seymour-Johnson Air Force Base, NC. The primary concern is the integration of an active and reserve component and how the organizational is structured based on the Program Guidance Letter, PGL L16-01, issued in July 2016. The overall intent is to explore the set-up of the organization and lessons learned so far in the process. The objectives of the I-Wing are to

better leverage the synergies and strengths of each component involved with stated goals of balancing capacity, capability and readiness. It is possible, as a result of this exploratory research, to have some solid inputs and potential course corrections on the structure of the current I-Wing as well as inputs for future integrated units and ways to maximize basing and resources.

### **Problem Statement**

The Air Force has established the I-Wing test program at Seymour-Johnson Air Force Base, NC. The purpose in establishing this program is to test The Commission's I-Wing concept utilizing the existing active association with the 916<sup>th</sup> Air Refueling Wing at Seymour-Johnson AFB. This pilot program is designed to assist the Air Force in determining if it possible to improve upon its current association structures with the desire of being more effective in mission accomplishment. This exploratory research is designed to examine the process from its inception to where it stands currently. Ideally, this exploratory research will examine areas of success, challenge and attempt to provide context for ways to continue to improve upon the I-Wing concept.

### **Investigative Questions**

After evaluation of the baseline documents to include The Commission's report, AFI 90-1001, and the Program Guidance Letter (PGL), a list of investigative questions was created. The primary investigative questions are listed above under the Research Objectives/Questions/Hypothesis section of this chapter. From this list of investigative questions, a list of interview questions was created and designed to ask participants for the purposes of completing the exploratory research and analysis. The intent was for these participant questions to be asked of leadership from the squadron to the wing level in order to assess the I-Wing program in its current state and assist in answering the investigative

questions. The questions can be located in Appendix 2.

## **Methodology**

Exploratory research is the primary method of research used in this study. To facilitate the research, a list of questions has been composed to answer the investigative questions and gather data to analyze and assess. Panel members consulted for this research consist of current members of the I-Wing in leadership positions at the squadron, group, and wing level. In addition, members of the Total Force Continuum (TF-C) office have been consulted. Complete copies of the questionnaire can be located in the appendix. Chapter IV will contain a thorough analysis of the information collected.

## **Assumptions/Limitations**

In evaluation of assumptions and limitations of this research, it is necessary to first evaluate the assumptions laid out within the Program Guidance Letter put forth by the Chief of Staff of the Air Force (CSAF) and Secretary of the Air Force (SecAF):

Assumption 1: The I-Wing structure will not be identical, nor implemented at every location.

Assumption 2: Factors such as location, mission, airframe, and composition will necessitate tailoring the exact I-Wing structure and framework to effectively accomplish the mission while still taking care of Airmen and families.

Assumption 3: Air Force squadrons will continue to support Combatant Commanders and meet day-to-day, home-station mission obligations with currently available operation and maintenance manpower.

Assumption 4: The budget will be constrained within the Future Years Defense Program (FYDP).

Assumption 5: Force structure and Unit Manning Document (UMD) changes may be necessary as changes that affect the 916<sup>th</sup> ARW, such as supporting the KC-46 conversion and other subsequent changes.

This research will assume that the US Air Force is committed to making this I-Wing Pilot Program work in an effort to replicate this program with the intent of realizing efficiencies and synergies in a resource constrained environment. Assuming this first assumption is complied with, and the program is a success, make the assumption that the Air Force will replicate the I-Wing program, in some form or fashion, allowing for cross component synergies across different mission areas within the USAF. The last assumption made is that the I-Wing pilot program will allow exposure of and to major administrative challenges.

### **Implications**

Total Force units and integrated command structures are the way forward for the Air Force. I-Wings will enable the service to continue to employ air and space power globally and properly present forces to the combatant commanders for the employment of air, space and cyber power globally. Excess infrastructure along with limited manpower will only cripple a resource constrained Air Force and its ability to project power globally. The I-Wing has the potential to leverage manpower, resources and basing that can and will enable the service to be agile, efficient and effective in the employment of air, space and cyber power across the globe as threats emerge. The Air Force will continue to rely heavily on its Reserve Components consisting of Air National Guard (ANG) and AFRC forces to project power globally and continue to maintain the capability in resources and manpower to effectively and efficiently accomplish the mission while sustaining battle-ready forces to the combatant commanders.

The KC-46 tanker is slated to be online soon, and the Air Force plans to place these new tankers within associate unit structures at the inception of fielding this new weapon system. The success of the I-Wing will enable the Air Force to be efficient and effective from the commencement of employment of these assets, as well as many other assets such as the F-35, and optimistically avoid pitfalls that would cause an overhaul of the system in a retroactive manner. If our Air Force is to continue to be efficient and effective in a fiscally constrained environment, limited resources and manpower along with ever increasing global threats, it is absolutely crucial that the Air Force sort out and effectively implement the I-Wing concept.

## **II. Literature Review**

### **Chapter Overview**

In setting out to explore the Integrated Wing (I-Wing) Pilot Program and the progress being made in the I-Wing Pilot Program, it is necessary to examine Air Force guidance, Joint Doctrine as well as other documents that outline the formation of the I-Wing. In examining the I-Wing program and exploring the progress being made, the researcher has chosen to evaluate the program from the perspective of Max Weber's Bureaucratic Management Theory. This research examines the background of the policies and guidance that preceded the formulation of the I-Wing in preparation of exploration. The intent of this chapter is to give background and insight on various issues and challenges that are coincident with the research questions constituting this research report.

### **Bureaucratic Management Theory**

In observing the I-Wing structure and examining opportunities to improve the structure, it is necessary to establish a framework with which to examine the structure. After careful research, multiple theoretical methods and models have been discovered that can assist with establishing a basis for examining the I-Wing structure. Due to the nature and scope of the research, not all theoretically relevant models or frameworks will be examined as it relates to the research.

The primary theoretical model to be examined is the bureaucratic management theory. This theory, established by Max Weber, postulates that bureaucratic management theory contains two essential elements, the structure of the organization into a hierarchy and clearly defined rules that enable governance of an organization and its members (Weber, 1983). As a military organization, this theoretical framework gives a baseline to

understand the military.

Further examination of bureaucratic management and a military organization, there are positive and negative aspects of this framework. Weber believed that the bureaucratic method was a very rational and efficient way to govern an organization, especially one of such large magnitude (Weber, 1946). From a theoretical point of view, a bureaucratic organization allows for smooth operations of a large organization. There are well-established hierarchies and echelons of leadership, as evidenced by an air force structure from the lowest levels of flights all the way up to the top through an Air Base Wing and further through to the Headquarters Air Force (HAF). In addition, theoretically, there are clearly defined rational rules and regulations that are defined in order to enable members of the military organization to complete their jobs, thereby contributing to the success of the organization as a whole. Unfortunately, over time, the clarity of the rules, regulations, legislation, and instructions become convoluted and give way to ambiguity. This ambiguity in the system leads to lack of efficiency and effectiveness.

In further understanding bureaucratic management theory, it is important to understand that a fundamental tenet of a bureaucratic organization is to have a well-established hierarchy. This established hierarchy leads to well-established lines of authority. Having well-established lines of authority in an organization enables members of an organization to have a clear understanding of whom one reports to, who one is responsible for, and so forth. These clear, established lines of authority and hierarchy provide an organization, especially a large organization comprised of many people, to operate smoothly and enjoy the benefits of efficiency and effectiveness (Weber, 1946).

When clear lines of authority and hierarchy are not evident in an organization, it can lead to chaos and confusion. When a member of an organization does not have definitive

roles, responsibilities and a specified reporting chain of command, efficiency and effectiveness will inevitably be lost. Further, if a member of an organization is subjected to multiple hierarchal structures and bosses, the member will be forced to decide which chain of command takes precedence. Throughout the research, this has proved to be a challenge of the I-Wing structure and will, therefore, be examined (Weber, 1983).

Further exploration of the concept of definitive lines of the authority is explained by the various legislative differences for each component. The formation of each USAF component is founded in legislation. The legislation established a structure designed for that particular component, without much, if any, consideration of the other components. It is postulated that for the ANG and AFRC, the legislation was designed to protect each component over time and to prevent the active component from overstepping boundaries unnecessarily. In theory, this design was meant to protect each organization. Unfortunately, with the establishment of the I-Wing construct, these protections, by way of legislation, are creating more challenges to the successful operation of an integrated organization with a single, integrated chain of command.

#### **National Commission on the Structure of the Air Force, 2014**

The National Commission on the Structure of the Air Force (The Commission), commissioned by Congress, released its report to the President and Congress in January of 2014 (United States, National Commission on the Structure of the Air Force, 2014). The report released was not regulatory in nature but presented recommendations on the future structure options for the Air Force. The Commission made forty-two (42) recommendations regarding force structuring. Of the forty-two recommendations, only one recommendation, which called for the dissolution of the Air Force Reserve Command, was contested.

The Commission stated that their report was meant to convey findings, conclusions and recommendations for the purposes of both legislative and administrative actions that have the interest of enabling and empowering the USAF to best manage its forces in the years ahead in budget, resource and personnel constrained environment (United States, National Commission on the Structure of the Air Force, 2014). The report highlighted many benefits and alternative approaches to Total Force or Total Force Integration (TFI) starting at the Headquarters Air Force (HAF) level all the way down to the squadron level of integration. The Commission stated that an objective of the report was to create an in-garrison model designed to better leverage the strengths of each component while balancing capacity, capability and readiness. The Commission also desired to recommend that the USAF have a greater reliance on the Air National Guard and the Air Force Reserve.

The Commission stated that they envisioned a Total Force that was seamless to and through airmen across the different components. Their recommendations had intentions to leverage personnel, resources, and basing while reducing personnel cost and producing a more “ready and capable” force. The Commission also stated an intent to preserve funds that could be redirected towards operations, maintenance, and procurement along with the recapitalization of equipment.

Further exploration of The Commission report reveals information contained in other historical documents and articles. Of note, The Commission highlights that many of their recommendations have been considered and tried in the past. The Commission contends that today’s Air Force is positioned, based on its forward-thinking approach, to make some of these recommendations happen. Making some or all of these recommendations happen will provide opportunities for the Air Force to create greater operational integration across the force.

In order to better understand elements of The Commission's report that impact the discussion of the I-Wing, this research highlights items within the report that assist in providing context to the I-Wing and what surrounds and supports the decision to develop such an organization. As stated previously, the commission provided forty-two recommendations. Of those forty-two recommendations, the research indicates multiple recommendations that directly or indirectly are contributory to the I-Wing in some form or fashion.

**Recommendation #3: Resourcing the Reserve Components:**

To ensure the Air Force leverages full capacity of all components of the force, in its FY 2016 Program Objective Memorandum, the Air Force should plan, program, and budget for increased reliance on the Reserve Components. The Commission recommends: (1) the Air Force should include in all future budget submissions a specific funding line for "operational support by the Air Reserve Component" to clearly identify those funds programmed for routine periodic employment of the ARC either as volunteers or under the authority of 10 U.S.C. §12304b; (2) in its future budget submissions the Air Force should program for approximately 15,000 man years of operational support annually by the Air Reserve Component; (3) in succeeding years, the Air Force should monitor the execution of this program element to ensure it is utilizing the Air Reserve Component to its fullest extent.

**Recommendation #5: Air Force Reserve Command:** Congress should amend 10 U.S.C. §10174 to retain the statutory rank, roles, responsibilities, and functions of the Director, Air National Guard, and Chief of the Air Force Reserve but **disestablish the Air Force Reserve Command. The Air Force should inactivate the Reserve Numbered Air Forces, wings, and squadrons.** The roles, responsibilities, and functions of disestablished organizations should be assumed by the Secretary of the Air Force, Headquarters Air Force, and MAJCOMS, all of which will have increased representation by Air Reserve Component Airmen, as determined by the Secretary of the Air Force.

**Recommendation #6: Staff Integration:** The Air Force should integrate the existing staffs of the Headquarters Air Force, the Air Force Reserve, and Air National Guard, similar to the principles recommended by the Total Force Task Force.

**Recommendation #7: AFR Unit Integration:** The Chief of Staff of the Air Force should direct the integration of Air Force Reserve associations of flights, squadrons, groups, and wings into corresponding Active Component organizations in order to eliminate the current redundant organizational overhead found in classic associations.

**Recommendation #12: Policy Revisions:** Integrating units will require manpower and personnel policy revisions. The Air Force should modify AFI 90-1001 “Responsibilities for Total Force Integration” to establish selection and assignment criteria, the minimum proportion of leadership positions that must be filled by the associating components, and the methods to ensure compliance. The AF/A1 and Air Force Personnel Center should then reassign Airmen in disestablished Air Force Reserve units to integrated Title 10 units composed of Active Air Force, Reserve, full-time and part-time Airmen.

**Recommendation #13: DOC Statements:** The Air Force should discontinue the practice of separate designated operational capability (DOC) documents for Active and Reserve units of the same type and place the i-Units under single DOC statements. An initial I-Wing pilot program should be conducted at an associate wing that has already established a record of success.

**Recommendation #14: Key Leadership Positions:** The Air Force should ensure that integrated units are filled competitively by qualified Airmen irrespective of component, but key deputy positions (such as vice, deputy, subordinate echelon commander) should always be filled by an “opposite” component member.

**Recommendation #15: Effective Control Measures:** The Air Force must establish effective control measures to ensure that both Active and Air Reserve Component Airmen have adequate paths and opportunities for advancement and career development.

**Recommendation #20: Increase ARC Capacity:** The Air Force should increase its utilization of the Air Reserve Component by increasing the routine employment of ARC units and individuals to meet recurring rotational requirements. The measure of success in this increased use of the ARC should be the execution of at least 15,000 man years annually.

**Recommendation #33: Duty Statuses:** Congress should reduce the number of separate duty statuses from more than 30 to no more than six, as has been recommended by the Quadrennial Review of Military Compensation and, more recently, by the Reserve Forces Policy Board. Reducing the number of duty status categories will make it easier for Air Reserve Component Airmen to serve in an operational capacity. The Air Force can implement this change in a way that does not diminish the overall compensation of Air Reserve Component members. Numerous provisions in current law that may require change are identified in Appendix J.

**Recommendation #34: Integrated Personnel Management:** The Air Force should unify personnel management for all three components under a single integrated organization (A1) in the Headquarters Air Staff. This is a different concept than an office that would oversee and integrate the activities of three separate component A1s. The Air Force should aggressively implement the “3 to 1” process but widen and amplify the effort to include integration of the three components’ personnel management processes for such matter as recruiting,

assignments, force development, and force management. A unified personnel management organization could best manage the portfolio of Air Force Specialty Codes and achieve the most favorable utilization rates, retention rates, and human capital cost controls.

**Recommendation #35: Integrated Pay and Personnel System:** The Air Force should accelerate the development of an Integrated Pay and Personnel System (AF-IPPS). The goal should be completion not later than 2016. The Air Force should ensure that this single system is capable of properly producing orders as well as accounting for and paying Airmen from all three components with a focus on providing a clear, simple structure under which the Air Force calls Air Reserve Component members to serve. This will result in an increased ability to plan, program for, and gain access to Air Reserve Component Airmen for any training and operational purposes. It will provide the means to capture the legal purpose and method of reimbursement of the Reserve Components for tracking and analyzing data.

Before moving along to the particulars, it is essential to note that The Commission made two broad, major recommendations that are pertinent to the research at hand. The first recommendation, major in change as it pertains to organizational structure, is an increase in overall number of associate units. The Commission suggested that each Active Component and each Air National Guard Component should have an associate relationship with a unit or element from another component. The second recommendation that was a major change is that each unit should have a “single, integrated chain of command” (United States, National Commission on the Structure of the Air Force, 2014). The Commission’s report designated these units as integrated units/wings or I-Wings. The model set forth by the commission is highlighted in Figure 1.

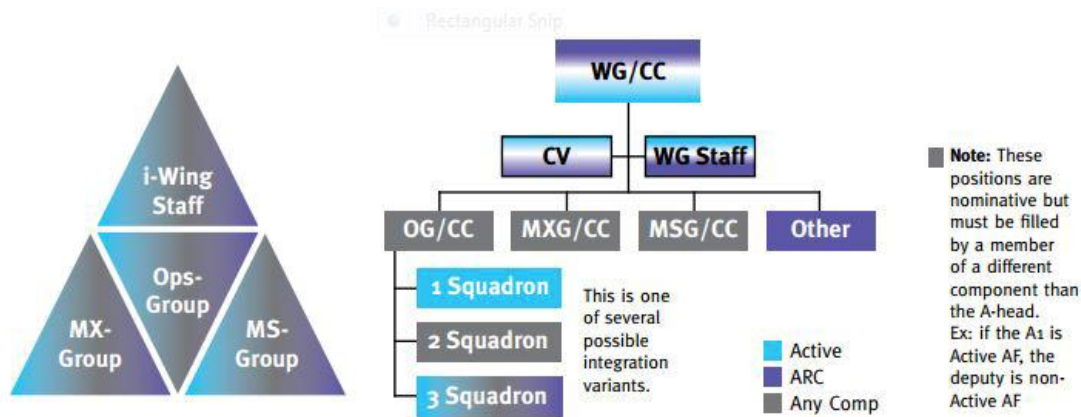

**Figure 1: Integrated Wing Leadership Concept from NCSAF (United States, National Commission on the Structure of the Air Force, 2014)**

Now that the recommendations that correspond to AFRC and the I-Wing program have been laid out, it is necessary to review the expectations of the commission as it pertains to the I-Wing Pilot Program. As stated previously, The Commission indicated that I-Wings should have single and integrated chains of command. Next, The Commission indicated that this integrated structure would and should go all the way down to the flight and squadron level with an integrated squadron being a mixture of reserve and active component flights. Ultimately, the integrated squadron would have airmen that are active component, full-time reserve members, and traditional/part-time reserve members. The Commission understood and acknowledged that legal and administrative issues such as Title 10, Title 32 and other legal statutes would need to be resolved in order to make these organizations happen the way they were envisioned by The Commission. As such, The Commission recommended that a number of I-Wing Pilot Programs be established with the intent of working through some of the legal, regulatory, administrative control, operational and tactical control issues that will need to be overcome.

To further understand the research as well as the background for the research, it is necessary to cover a baseline level knowledge. To facilitate this baseline level of

knowledge, some terms will be described.

## **Association Types**

**Active Association (Active Associate Wing)**: An integration model that combines Active and Reserve elements, with the Reserve Component retaining principal responsibility for a weapon system and sharing the equipment with one or more Active Component units. The Active and Reserve components maintain separate organizational structures and separate chains of command. This is important as there will, under most and normal circumstances, be a separate active duty wing structure along with a unique Unit Manning Document (UMD). Additionally, the Reserve Component will have its own wing structure, staff, and UMD operating on the same installation. The principle distinguishing factor in an organization that is an Active Association is that the Reserve or Guard component is the “owner” and maintainer of weapon systems. An example of an Active Associate unit is the 932<sup>nd</sup> Airlift Wing at Scott Air Force Base, Illinois. The Reserve Component unit is principally responsible for the unit’s C-40 aircraft while the Active Component, the 375<sup>th</sup> Air Mobility Wing, will share in flying the aircraft and missions.

**Classic Association (Classic Associate Wing)**: An integration model that combines Active and Reserve Component elements, with the Active Component retaining principal responsibility for a weapon system and sharing the equipment with one or more Reserve Component units. Today, the Active and Reserve units retain separate organizational structures and chains of command similar to the Active Associate model. An example of a Classic Association can be seen at Charleston AFB, SC with the 315<sup>th</sup> Airlift Wing being the Reserve Component alongside the Active Component, the 437<sup>th</sup> Airlift Wing.

**Integrated Wing (I-WING)**: An integration model that combines Active and

Reserve elements within one organizational structure and chain of command, with members of all components contributing to a common unit mission.

**Program Guidance Letter L16-01 (PGL L16-01)**

The PGL provides guidance and direction necessary to implement the I-Wing pilot program with the 916<sup>th</sup> Air Refueling Wing (916 ARW) (Air Force Reserve Command) at Seymour Johnson Air Force Base, North Carolina (SJAFB). The 916<sup>th</sup> ARW existed as an active association with the 916<sup>th</sup> ARW and the 911<sup>th</sup> Air Refueling Squadron (911<sup>th</sup> ARS). The 916<sup>th</sup> ARW was an AFRC unit while the 911<sup>th</sup> ARS was an active component squadron that reported to the 6<sup>th</sup> Air Refueling Wing located at MacDill AFB, FL with a reporting chain of command up through 18<sup>th</sup> Air Force at Scott AFB, IL. It is worth noting that the 916<sup>th</sup> ARW was chosen as it was already a relatively successful Active Association at SJAFB with a host Air Combat Command Wing. This PGL was designed to lay out how the unit was going to transition from an Active Association to an I-Wing. Contrary to the envisioned desire of The Commission, existing laws, in addition to the Constitution, prevent certain changes to enable a single unified chain of command. The I-Wing pilot program was designed to test out one type of construct to get as close as possible to the desired end state.

Legal constraints inhibited the full integration to a single chain of command for the 916<sup>th</sup> ARW. The PGL laid out a construct that enabled the 916<sup>th</sup> ARW to get as close to a single, unified chain of command as possible. The construct that was decided upon was a parallel unit at the group and wing levels with a Dual Hat Commander (DHC). This structure provided for group and wing level administrative control or ADCON and chain of command authorities for both active and reserve component members. The primary concept was to integrate the active and reserve component units.

Unfortunately, due to legal constraints, it was not possible, at the time, to create a single entity that could manage both active and reserve component units. Based on the constraints, this pilot program has totally separate legal entity organizations that happen to have similar names for the active component to the previously existing reserve component organization. The pilot program effectively created a parallel active component organization at the wing and operations group level to enable a single, Dual Hat Commander to command both active and reserve component units. For the purpose of comparison, Figure 2 lays out a graphic representation of the original associate program structure, while Figure 3 lays out the new pilot program structure.



## Prior Structure 916 ARW Seymour Johnson AFB, NC

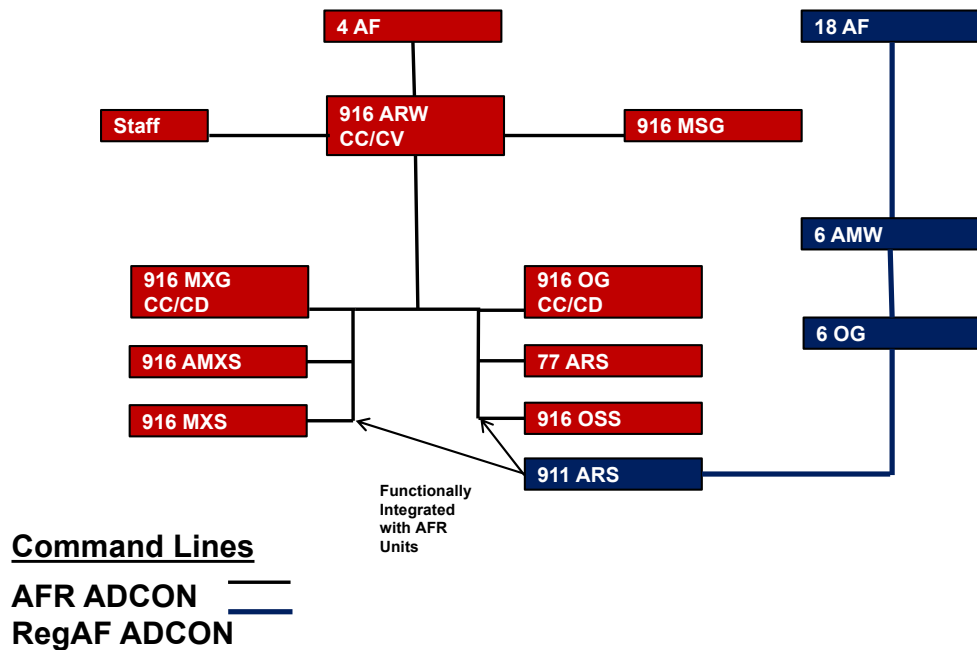

**Figure 2: Active Association Structure (Pohlsander, 2016)**



# Current Structure Dual-Hat Command

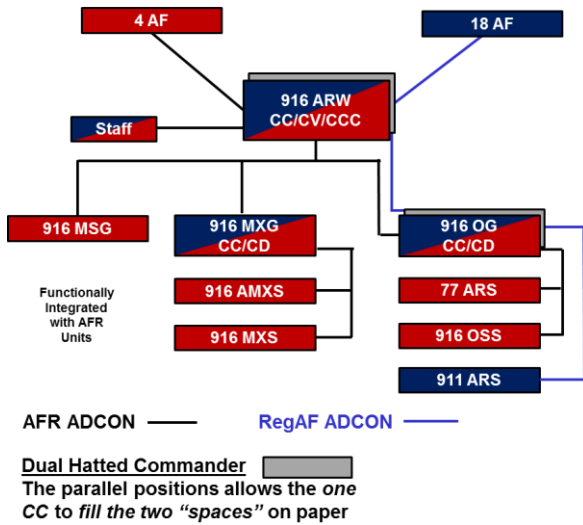

- Establishes an AC Wing and Group to satisfy legal requirements
  - 2 UMDs, parallel orgs (Wg & Gp)
  - Allows for 1 face, 2 spaces (ARW/CC, OG/CC)
- Considerations
  - Most transferable construct
  - Min ETPs/legal changes
  - 18 AF retains tasking channel (OPCON) to 911 ARS
  - Requires activating new organization to establish ADCON over RegAF unit
  - Removes "ties" to 6 OG

16

**Figure 3: I-Wing Structure with Dual-Hat Commander (Pohlsander, 2016)**

The course of action (COA) out of many COAs considered, established an identical active component wing and group that allowed for the satisfying of legal requirements.

This new structure can be seen in Figure 3. This structure created two separate unit manning documents for each of the parallel organizations. Utilizing the Dual Hat Commander (DHC) COA allowed for a one face in two spaces for both the 916<sup>th</sup> ARW and 916<sup>th</sup> OG respectively. This COA allows for both a DHC and a dual component command meaning that the commanders for the 916<sup>th</sup> ARW and 916<sup>th</sup> OG will command the respective parallel organizations and can have a commander that is from the active or reserve component. The vice commander for each organization will be from the alternate component. This alternate component mixture complies with The Commission's

recommendation. For example, the current 916<sup>th</sup> ARW commander is from the Reserve Component which thereby requires that the deputy commander or second in command, is from the Active Component. These component positions will alternate as each commander changes out.

It has been determined that this COA is the most transferable to additional I-Wing organizations in the future. This structure allows for the most unity of effort while requiring minimal legal changes and exceptions to policy. As it is laid out in this COA, 18<sup>th</sup> Air Force (18 AF) retains tasking authority and Operational Control (OPCON) of the 911<sup>th</sup> ARS. The parallel active organization allows for the Administrative Control (ADCON) over the 911<sup>th</sup> ARS. This restructuring, as evidenced by comparing Figure 2 to Figure 3, removes the administrative connection to the 6<sup>th</sup> Operations Group, which was located in Florida compared to the new parent organization co-located at SJAFB.

### **UCMJ Authority**

Airmen operating at home station, in garrison, operate under different rules dictated by the component of service. Some rules are transcendent across the three components while other laws, statutes, rules, Air Force Instructions (AFI), and Air Force Directives (AFD) are specific to each component. When airmen operate at a forward deployed locations, in support of contingency operations, there is no differentiation of rules and regulations across the three components due to Title 10 authorities. This in garrison differentiation of laws, statutes, rules and regulations present some unique challenges for the Integrated Wing (I-Wing) concept. There is a need to organize, train and equip our airmen to the same standard, across all components, so that our airmen are prepared to execute the mission of the designated combatant commander (CCDR). In order for the I-Wing concept to succeed, and be replicated across other organizations, it is imperative that

the organizational structure, administrative structure, administrative control as well as supporting structures be in place to provide effective synergies.

### **Unity of Command**

Unity of Command is defined with clarity in Joint Publication 3-0. It is necessary to explore what the joint publication states to form a basis of understanding and how this presents a challenge for the I-Wing. According to JP 3-0, “The purpose of unity of command is to ensure unity of effort under one responsible commander for every objective.” Further, JP 3-0 states that Unity of Command is the operation of all forces under a single responsible commander who has the requisite authority to direct and employ those forces in pursuit of a common purpose” (U.S. Joint Chiefs of Staff, 2017).

In the evaluation of Unity of Command, as it pertains to the I-Wing and the challenges faced, there are some questions that have arisen. The first question that presents itself is who is in command, followed by when are they in command. This question is important as it dictates how members of an organization decide who and how they respond on a daily basis. When evaluating this question, with regard to Weber’s Bureaucratic Management Theory, members need to know, at all times, who is in command. Airmen also need to know who it is they work for. It is unfair to airmen and members of an organization to have ambiguity with respect to command relationships. As it stands, based on the parallel organization structure of the I-Wing as well as the DHC structure, members and airmen are left with a sense of potential confusion and obscurity with respect to OPCON and ADCON. A unit owes its members and airmen more than vagueness and ambiguity.

Next, it is necessary to know who has tasking authority of an organization and the members of an organization. Tasking authority has unique challenges and slightly differing

definitions at the joint level than at the unit level in an organization such as the I-Wing. These differences can become especially challenging in an I-Wing when you are dealing with members that are on different status. For example, in order for the 916<sup>th</sup> ARW Commander, as a reserve component member, to command the unit's active duty members on G-series orders, the commander has to be on active Title 10 orders for at least 90 days. Lastly, who has administrative control and what challenges does this present?

In examining the concept of Unity of Command, it is important to reflect on bureaucratic theory and the idea of a clean hierarchal structure and chain of command. In the most simplistic form, this allows a service member to know to whom they report to. This is important as knowing this can help to decide which task will be accomplished and when. For example, if a supervisor, that writes the members performance reports, ask the member to accomplish a task, it is likely the member will do the task. It is also likely that the member would complete a task if asked by a senior member that does not write the member's performance report. The challenge is encountered when the member is asked, simultaneously by both senior members, to accomplish separate tasks. It is at this point that the member has to decide whose task will be accomplished with priority. When the tasks are simple and trivial, being that the USAF has some of the most professional airmen and people in the world, it is possible for the member to handle them both with ease and not create any conflicts. The challenge is magnified for the airmen when the tasks happen to be complex and competes for an Airman's time, it becomes a challenge and a decision has to be made as to which tasks and which authority figure will gain the priority. This competition is usually solved by satisfying the person that writes the performance report, in an effort to ensure satisfactory ratings.

## **AFI 90-1001**

This AFI, recently updated with a major overhaul and changes, was released in January 2017. This AFI is designed to assist with planning for Total Force (TF) organizations within the Air Force. Based on the USAF Strategic Master Plan, AFI 90-1001 attempts to capitalize on agility and inclusiveness of various USAF components to meet the Nation's National Military Objectives (U.S. Air Force, 2017). As outlined in this AFI, TF organizations are structures that allow USAF components to share resources to perform common missions. This AFI outlines the roles and responsibilities necessary for the development and evaluation of Total Force organizations (U.S. Air Force, 2017).

Command relationships, as it relates to associated organizations, are also outlined in AFI 90-1001 (U.S. Air Force, 2017). The AFI states that each associated organization will retain administrative control (ADCON) of their forces. In addition, each associated organization will maintain its own organizational structure, Unit Manning Document (UMD) and separate chain of command (U.S. Air Force, 2017).

### **ADCON Overview**

Administrative control or ADCON is a term that is necessary to be defined and understood as it pertains to this research and how it impacts the I-Wing. According to Annex 3-30, Command and Control, ADCON is defined as the "direction or exercise of authority over subordinate or other organizations with respect to administration and support (U.S. Joint Chiefs of Staff, 2014)." Further, ADCON includes organization of forces, control of resources and equipment, logistics for respective unit, unit training, unit readiness, unit mobilization, demobilization, discipline, and other pertinent matters not inclusive in operational missions (U.S. Joint Chiefs of Staff, 2014). It is important to note that ADCON is not a wartime authority. Under normal circumstances, G-Series orders

implement and execute ADCON authorities.

### **OPCON Overview**

Operational control or OPCON is a term that is utilized for in garrison and combat operations. OPCON is important concept and definition to grasp as it pertains to the I-Wing and the units belonging to the 916<sup>th</sup> ARW.

Regarding OPCON, the I-Wing Pilot Program, and the 916<sup>th</sup> ARW, it is necessary to fully understand that the 916<sup>th</sup> ARW and AFRC do not exercise OPCON over the members of the wing. The primary role of the 916<sup>th</sup> ARW, 4<sup>th</sup> AF and 18<sup>th</sup> AF is to provide for the Organization, Training and Equipping (OT & E) of the units. This allows for forces to be properly prepared to be presented to AMC in order for the forces to be presented forward for contingency operations. Unfortunately, due to how terms are utilized, the term OPCON is often used in a way that is not in alignment with the Joint Publications that outline command relationships.

AFRC is responsible to present forces to AMC who further presents forces to a Combatant Commander for actual OPCON during contingency operations. With regard to training and exercises, AFRC authorizes and funds the training missions, however, technically speaking, this is not considered OPCON, this is simply OT & E. For the purposes of this research and to assist in a more thorough understanding, 18<sup>th</sup> AF retains responsibility for OT & E of the 916<sup>th</sup> ARW (Active Duty) and consequently the 911<sup>th</sup> ARS. Simultaneously, AFRC and 4<sup>th</sup> AF is responsible for OT & E of 916<sup>th</sup> ARW (AFRC).

### **Operational Direction (OPDIR)**

Operational direction (OPDIR) is a relatively obscure term that has been misunderstood as it pertains to the Air Force (U.S. Air Force, 2017). According to AFI 90-

1001, OPDIR is necessary when associated organizations and their personnel are not in the same ADCON chain-of-command. AFI 90-1001 states that MAJCOMs must set general guidelines and integration lines within and for associated units. These guidelines and appropriate OPDIR allows for unity of effort among the associated units.

**Operational Direction (OPDIR)**—OPDIR is a Service specific term that describes the authority of a member of one component to designate objectives, assign tasks, and provide direction to members of another component necessary to accomplish steady-state duties other than operational missions and ensure unity of effort. OPDIR further clarifies coordinating authority doctrine administered between Air Force commanders through MOUs and MOAs to achieve unity of effort in the context of steady state organize, train, and equip activities and missions. OPDIR enables functional supervisors from any component to direct personnel from another component detailed under their supervision, and does not apply in the context of military operations under the command and control of a Combatant Commander (U.S. Air Force, 2017).

**Unity of Effort**—Coordination and cooperation toward common objectives, even if the participants are not necessarily part of the same command or organization, which is the product of successful unified action (U.S. Joint Chiefs of Staff, 2016).

### **III. Methodology**

#### **Chapter Overview**

The purpose of this chapter is to describe the research method used while conducting this case study using exploratory research. This research starts with a discussion covering the design of the research. Next, the researcher will cover the data collection method used. After examining the data collection methodology, this research will explain the qualitative data analysis process used to uncover emergent themes that will be helpful for understanding the issues at hand as well as enable follow-on researchers to assess the issue. Finally, this chapter will conclude by describing what strategies the researcher implemented to ensure validity and reliability of this exploratory research.

#### **Research Design**

Exploratory research is conducted with a problem set that has not been studied previously or with clarity. Exploratory research is designed to establish priorities and develop operational definitions that will enable the improvement of a final research design (Shields & Tajalli, 2006). Additionally, Shields & Tajalli state that the purpose of conducting exploratory research is to help determine what might be the most appropriate research design, data collection methods and the manner in which subjects are selected. Shields & Tajalli further explain that exploratory research is not designed to provide any definitive conclusions. If definitive conclusions are drawn, extreme caution has been advised by multiple referenced sources including Shields & Tajalli. Interestingly enough, it has been stated that exploratory research often concludes that there is no existence of an actual problem, only the perception of a problem.

Exploratory research is valuable tool when there is a desire to increase awareness with or advance new understandings into or of an issue in an effort to formulate a more

precise problem or develop a potential hypothesis (Kumar & Singh, 2011). It is for this reason that exploratory research is being utilized to explore the Integrated Wing (I-Wing) construct as it is currently being presented. It is possible that the researcher can acquire a better understanding of the potential problem set and create additional avenues for research to better enable the U.S. Air Force (USAF) to utilize the I-Wing construct in other USAF organizations. The goal of the researcher in this case study is to formulate a relevant hypothesis by way of experience and knowledge gained through this exploratory research. Upon conclusion, the desire and intent is that a basis for a more definitive investigation will be presented to the audience.

According to Dewey, exploratory research results are not ordinarily valuable in the process of decision making, without additional data (Dewey, 2013). It is important to note that exploratory research, even though not useful to make decisions without additional data, can be instrumental in providing significant insight into a given situation. As such, this exploratory research of the I-Wing construct is intended to provide insights for USAF leadership and provide information that might be helpful in current and future Total Force organizational structures.

Dewey (2013) further classifies exploratory or preliminary research as a “working hypotheses” that are designed to signal the preliminary stages of conceptualization. The intent of exploratory research as a micro-conceptual framework, according to Dewey, is to “provide a provisional, working means of advancing investigation (Dewey, 2013).” This method has the ability, and is intended to lead to the discovery of other, unknown, critical facts (Dewey, 2013). In working through the design of exploratory research, it is necessary to collect evidence that can either support or potentially fail to support the expectations of the research (Shields & Rangarajan, 2013). This research is supported with empirical

evidence by way of the I-Wing being an experiment and utilizing surveys to gather supporting data and information.

Qualitative research results can be used to provide indications for when, why and how something occurs in a given situation. The limitations of the qualitative research are that it cannot clearly reveal quantitative data such as how often or how many. In some instances of this research it is possible that there will be quantitative data provided by research subjects, but it is imperative to note that this exploratory, qualitative research is designed to gain insight, not to provide specifics regarding numbers.

### **Data Collection Methods**

This section will cover the data collection and data preparation methods utilized for this research. This section is intended to describe why and how each participant was chosen for this research. Further, this section will explain how the questionnaire questions were crafted. Additionally, this section covers how the data was collected. Finally, this section will explain how the data was prepared for analysis.

### **Interview Participants**

Interview participants were selected based on leadership roles within the organization that was being evaluated. Participants were chosen based on current leadership roles and position within the 916<sup>th</sup> Air Refueling Wing (916<sup>th</sup> ARW) at Seymour-Johnson Air Force Base, NC. The selection of members across the 916<sup>th</sup> ARW enabled the researcher to get a cross section of sub-organizations and different specialties, enabling the researcher to assess and evaluate commonalities and unique differences within the overall organization. The researcher attempted to target and gather data from the lowest level of Squadron Operations Officer (SQ/DO) all the way up through the Wing Commander (WG/CC). In addition, the researcher attempted to solicit participants from a

cross section of Active Duty Component (AC) and the Air Reserve Component (RC).

Interviewed participants were chosen based on being in a current position and solicited for participation via e-mail. This solicitation offered the option of filling out the questionnaire or doing the survey via a phone interview. There were two participants that chose the phone interview option. The research and interviews was conducted from November 2016 through April 2017.

### **Interview Format and Medium**

The phone interviews were conducted in a semi-structured format that happens to be appropriate for opportunities that might be a one-time event engagement for the researcher and participant (Bernard, 2006). Additionally, regarding the semi-structured formatting, Bernard implies that this format works well when dealing with high-level or elite members of a community, that expect efficient usage of their time (Bernard, 2006). Each participant, being in a command or deputy commander position, was viewed by the researcher as an elite member of the community of interest. Based on the timeline of the researcher and the time constraints of the participants, the researcher expected and planned for questionnaires and phone interviews to be exclusive, one-time events.

### **Survey Description & Protocols**

In structuring the survey, the researcher utilized the Interview Protocol Refinement (IPR) Framework, as laid out by Castillo-Montoya, to develop the required research tool. Table 1 outlines the phases that are utilized in the IPR Framework and outlines the objectives of each step (Castillo-Montoya, 2016). The researcher, as part of exploratory research, has utilized each step informally. Phase 4 of the IPR has been utilized, with the circulation of questions to the initial participants. Additionally, the researcher circulated the same questions to peers. Lastly, and for purposes of comparative and thematic analysis,

the researcher circulated the questions to the office responsible for establishing and administering the I-Wing.

**Table 1. Interview Protocol Refinement (IPR) Method (Castillo-Montoya, 2016)**

Phase	Purpose of Phase
Phase 1: Ensuring interview questions align with research questions	To create an interview protocol matrix to map the interview questions against the research questions
Phase 2: Constructing an inquiry-based conversation	To build an interview protocol that balances inquiry with conversation
Phase 3: Receiving feedback on interview protocol	To obtain feedback on interview protocol (possible activities include close reading and think-aloud activities)
Phase 4: Piloting the interview protocol	To pilot the interview protocol with small sample

In assessing the data, the researcher has chosen to do a basic and initial coding of the data. In the process of creating the foundation for this exploratory research data, the researcher has chosen to group the data into main categories. This grouping allowed the researcher to create questions intended to gather information pertaining to the specified grouping of questions. In preparation for this survey, it was necessary to create main analytic categories. Upon collection of the data, the researcher then utilized thematic analysis in an effort to search for frequencies and similarities of responses that will enable approximation of relative levels of importance of themes and sub-themes.

## **Data Collection**

Data was collected via direct e-mail response and via phone interviews. Responses to the survey questions were free text answers to open-ended questions. This enabled participants to provide the widest range of responses to questions without being inhibited by way of limited selections for each question. The questions, as a whole, covered key areas of interest. The list of questions can be found in Appendix B.

Participants were asked for basic demographic information regarding their positions, rank, title, and component affiliation. Participation in this survey and collection of data was completely voluntary. The responses to the surveys have been collated with an emphasis on ensuring anonymity throughout the research and presentation of findings. Any information collected that might identify a participant will not be linked to survey responses.

## **Data Analysis**

The researcher analyzed the data utilizing a thematic analysis, with an emphasis on categories of responses. Three primary steps were adhered to in the analysis of the data. More specifically, the three steps utilized was familiarization with survey responses for each question, development of codes for question responses enabling a coding framework, and categorization of codes into associated themes and subthemes (Braun & Clarke, 2006).

Once all the data has been sorted into appropriate themes and assessed, the researcher will analyze the data. The method for analyzing the data will be covered in Section IV. The researcher will utilize thematic analysis. The objective of the thematic analysis will be to identify recurring themes throughout the data.

## **Summary**

This exploratory research utilized interviews/surveys as the primary method for data collection. The researcher selected participants based on leadership roles within the 916<sup>th</sup> ARW, both active and reserve component members. Participants were initially contacted via e-mail and some participants interacted via a phone call prior to completing the survey questionnaires. All interviews were sorted, coded and grouped by themes by the researcher for broad theme analysis. The general categories that questions were segmented into the following categories: I-Wing Structure, OPCON, ADCON, and Unity of Command.

## **IV. Analysis and Results**

### **Chapter Overview**

This chapter will cover the analysis and results of the exploratory research conducted by way of thematic analysis. The intent of thematic analysis for the purpose of this exploratory research is to locate major themes and concepts, not to test those themes and concepts. An area where thematic analysis is utilized thoroughly is within the health field related to social science issues. The survey yielded seven (7) total responses. Two responses were via phone while the remaining five responses were via e-mail. The two responses via phone revealed pertinent data but after thorough review, did not provide a level of fidelity similar to the responses of written answers. The researcher will lay out each question and show the results based on the data collected.

### **Unity of Command**

Total Force Integration Policy, outlined in AFPD 90-10, gives details and outlines the structure of an integrated association (U.S. Air Force, 2006). This outlined integrated association is comprised of members from different components under one organizational umbrella and one chain of command. The I-Wing organization at Seymour-Johnson attempts to follow some of this guidance, however, the PGL initiated changes that would move toward a single chain of command. Based on legal statutes and other congressionally mandated hurdles, it is hard, if not impossible, at the present time, to institute a single organization with a single chain of command. The PGL attempted to sidestep these hurdles by creating a separate organization that allows for a Dual Hat Commander (DHC). This DHC, per the PGL, is the WG/CC for an AC and a RC wing. Figure 2 and Figure 3 show the before and after command structure for the 916<sup>th</sup> ARW.

Research has shown past Professional Military Education graduates have written

about the challenges that exist regarding unity of command for organizations that contain airmen from more than one status such as Active Component and Reserve Component airmen. The military, and consequently the Air Force, have long ago figured out how to integrate forces and airmen in the combat environment. The reason for the success in utilizing forces in the combat environment is due to the transition from a reserve or guard status to an active, Title 10 status. For the purposes of this research, the analysis and discussion of unity of command is not so much concerned with fundamental employment and disciplining of forces under the UCMJ and in combat environments, rather the concerns are predicated upon an effective organization as laid out by the bureaucratic management approach as it pertains to an in garrison unit.

As set forth by Max Weber in his 6 principles for bureaucratic management, an organization needs to have a chain of command and/or an organizational hierarchy that allows information, decisions and work to flow effectively from top to bottom (Weber, 1946). These principles allow for an organization to effectively make decisions, control resources and protect the workers, or airmen in this case study. When viewing the I-Wing concept through this lens, there is not a true unity of command. By installing a DHC, commanding an active component and a separate reserve component wing, there are still two overarching organizations that must be adhered to. Following the reserve component chain of command, information flows from 916<sup>th</sup> ARW WG/CC to the 4<sup>th</sup> AF/CC then up to the AF Reserve Command Commander. Follow the active component chain of command for 916<sup>th</sup> ARW and you go from 916<sup>th</sup> ARW WG/CC to 18<sup>th</sup> AF/CC then up to Air Mobility Command Commander. As laid out, there are effectively two chains of command that the 916<sup>th</sup> ARW/CC must answer to. This has the potential to create challenges and ripples at the lowest levels.

**What is the root-cause for the I-Wing pilot program delay?**

This question was settled upon as a central question of the survey. Upon review, after data collection, the researcher determined that this question was not a suitable central question. Fortunately, more than 75% of the respondents answered this question and it provided some insights on the perspectives of members of the 916 ARW as well as perspective from the Total Force Continuum (TFC) office. The strongest theme that emerged out of this question was that the term “delayed” was interpreted differently by the participants. Beyond the difference in interpretation of delay, there was a consistent theme that emerged recognizing that all the components, administrative and logistical needs were not in place and/or finalized prior to the I-Wing program starting in 2016.

Of note, according to the PGL, Item 5 on the strategic milestones sets forth a due date of 15 August 2016 for the Inter-MAJCOM Programming Plan (P-Plan) to be signed. At the time of the surveys and data collection, the P-Plan was not complete. An Inter-MAJCOM P-Plan is important, as noted in AFI 90-1001, as it identifies programming actions required where two or more major commands (MAJCOMs) require actions in order to meet an objective. In the case of the 916 ARW, there are three MAJCOMs involved, Air Mobility Command (AMC), Air Combat Command (ACC), as the host base and wing, and Air Force Reserve Command (AFRC). AFI 90-1001 also acknowledges lead-time and coordination required by each MAJCOM involved prior to publication.

The P-Plan is just one item of note that happened to not meet the timeline set out by the Strategic Milestones as laid out in the PGL. Another item of interest happens to be the Pilot Program Measures of Merit. As such, the researcher determined that the data collected was sufficient to assist in formulating a theme relative to this question.

**What actions can be taken to facilitate a timely Integrated Wing transition?**

This question was also utilized as a central survey question as part of the research and data collection. This question was established based on the timeline set forth in the PGL that established the I-Wing as well as the changes that were set to take place to make this new structure effective. Further, the idea behind this question was to observe if the organization would be able to adhere to the timeline set forth by the PGL Strategic Milestones and if there was a necessity for additional actions to facilitate a timely transition. As previously stated, there are areas where there not been adherence to the timeline set forth. This lack of adherence was cause for the researcher to be concerned with the ability of the organization, given the compressed timeline, to meet the stated milestones.

The recurring theme that emerged from this survey question was something common with most programs. The theme that surfaced was the necessity for more personnel, more and continued support and resources. The participants thought that it was imperative that support and resources be provided at the applicable levels of leadership.

***Are we on track to meet the timing and goals to transition between all four phases of the Program Guidance Letter (PGL) L16-01?***

Once again, this question is addressing the timing and Strategic Milestones set forth in the PGL. The researcher intended to gather data utilizing open-ended questions that might provide additional insight that would support the primary research questions. The researcher expected to gain insight into not only the timing and transition among the different phases but possibly information administrative challenges that impede the timely transition of phases.

After evaluation of the data, the emergent theme for this question was the publication of the P-Plan and Integration Plan (I-Plan) and how those correspond with Initial Operational Capability (IOC). Looking at the Concept of Employment laid out in

the PGL, Phase II was slated to start in October 2016. Phase II was structured to be the Pilot Program lasting from October 2016 through October 2019. Phase II IOC requirements were addressed with a timeline ranging from October 2015 through 1 October 2016, whereby IOC was scheduled and declared on 1 October 2016. One of the items required in declaring IOC, according to the PGL and the Strategic Milestones, is the I-Wing P-Plan. According to the PGL, the I-Wing P-Plan lays out actions that are needed to meet IOC and Full Operational Capability (FOC). As it stands, from the TF-C office, the I-Wing P-Plan is not complete and FOC is slated to happen on 1 July 2017.

Participants recommended that the I-Wing FOC should be structured to be at least a year from the publication of the P-Plan and I-Plan. Currently, IOC was 1 October 2016 and FOC is scheduled for 1 July 2017. This is a nine-month period of time to learn lessons and assess the progress of the IOC portion of Phase II. The P-Plan provides guidance to move from IOC to FOC. As it stands, there is no P-Plan in place to help facilitate the transition to FOC on 1 July 2017.

**What can be done to facilitate the administrative challenges during the I-Wing transition?**

The emergent theme from this question shows that participants overwhelmingly noted that access to various systems, proprietary in nature to each component, was a major impediment to the transition. In evaluating this question, it is important to note that The Commission pointed out issues and challenges of the USAF administrative systems. The Commission stated that each component had its own stand-alone system that did not communicate with the other components. As such, The Commission laid out requirements to align the administrative systems into a single system. At a minimum, it would be helpful to have systems that can communicate across components. The commission also was

adamant about reducing the administrative barriers between the three components.

**Can you tell me about/could you describe in as much detail as possible the I-Wing concept and how Seymour Johnson AFB, NC is integrating the construct?**

The researcher placed this question with an intent to identify, if possible, what level of understanding lower level leadership were provided regarding the I-Wing Pilot Program. It is possible that this question could have been better worded to evoke a more usable response. None the less, the emergent theme that emanated from participants was the idea that the I-Wing Pilot Program is a simple concept but difficult to execute and implement. This is important perspective to annotate from the participants.

**What challenges were expected during the transition during Phase 2, pilot program?**

Similar to the previous question, this question was designed to gain insight on the level of education provided to lower level leadership. The researcher placed this question with an intent to probe the level of education and preparation provided. If proper education and preparation is not provided, it is ever more challenging for the lower level leadership to implement such an undertaking as the I-Wing Pilot Program. The emergent theme(s) that evolved with this question is that there are challenges with identifying consistent and cohesive methods of working in addition there were challenges with educating personnel regarding changes anticipated during Phase II of the Pilot Program.

**What successes were expected during the transition?**

The emergent theme from this question was that there was no clear understanding of how success was defined or measured. Participants indicated that there was no defined program success and if there was a definition, it was not communicated well to lower-level leadership below the wing level. The researcher had conversations with HAF leaders and Wing-level leadership. At the time of this research, the Wing leadership and members at

the HAF level consider the I-Wing program a resounding success thus far. Some of the determinants for success are based on various wing inspections that were monumental for any associate unit.

**Have there been any other unexpected successes?**

The emergent theme for this question was similar to the emergent theme regarding expected success. Similar to previous questions, this question was challenging for participants to answer based on a lack of defined measurements of success. Participants voiced that program success, if any, was not readily identified or communicated. Additionally, there was concern from participants that the communication of this unknown measurement relied on someone else, perhaps outside entities, to identify successes.

**What actions, in Phase 2, must occur to enable the transition to Phase 3?**

The emergent theme from this question here is a need to capture the lessons learned. Participants were adamant regarding the necessity to capture any and all lessons learned in Phase II. Participants also expressed concerns for how some of the active duty manning will be handled. More particularly, the maintenance troops and the manner in which they work in garrison creates some challenges moving forward. Due to time available and the scope of this research, the management of maintenance personnel was not evaluated further.

**Where do you perceive there to be bottlenecks in Phase 2 which may delay the transition to Phase 3?**

The emergent theme for this question was the need to garner buy-in from the participating MAJCOMs and the participating components. Additionally, similar to previous questions and themes, participants indicated that access to personnel systems, across components, is perceived to be a concern in the transition from Phase II to Phase III.

**What processes, facilities, personnel, or costs have been identified as duplicative in the process thus far?**

The emergent theme presented in this question is that no duplicative processes have been identified, per the participants, at this time. This emergent theme presents a slight cause for concern, but maybe only slightly. The reason for concern on the part of the researcher is that part of the push for the I-Wing, as previously stated, is to identify and eliminate duplicative processes, facilities, personnel and/or costs. Participants indicated that it was possible that some processes are duplicative but have not been registered as such due to different MAJCOM chains of command and requirements.

**How has admin support and control been impacted by the I-Wing transition?**

The emergent themes from this question are the learning process and the “standard” growing pains and challenges of implementing such a change in a military organization. Also, similar to previous questions, a recurrent theme from participants is system access across components. Some participants indicated their concern that the reasoning for lack of cross component access might be predicated upon trust issues. In order for any combined organization to work effectively, there must be trust. Each component, from the top all the way down to the front line airman, must have trust for the other component in order to achieve a true measure of success, even if loosely defined.

**How have administrative processes been impacted during the transition, positively or negatively?**

The emergent theme for this question is the impact on the administrative processes has been challenging, but most participants noted that these challenges were viewed as short-term in nature. Also, participants indicated that the learning process across components will be imperative to combat this challenge. Participants indicated concerns

for writing style for performance reports and how they differ from one component to the next. To ensure members are taken care of, it will be necessary to make sure that their supporting documentation such as awards packages and performance reports are written appropriately for the component. In order for the I-Wing to work effectively, component participants must feel that their personnel are taking care of equally to their component counterparts.

***Has progress been made toward an integrated chain of command? Why or why not?***

The emergent theme for this question was that progress has been made (and will be the most notable) with the administrative processes. The researcher placed this question not realizing fully the intent of the I-Wing Pilot Program and what it means to have an integrated chain of command. For reference, the I-Wing chain of command structure is a Dual Hat Command structure with two separate organizations being run by one commander. This effectively negates the concept of a fully integrated chain of command that was desired by The Commission.

***What positive and/or negative impacts has the dual-hat structure of RegAF/AFRC structure had?***

This question did not necessarily have an emergent theme by all participants but there are comments that are worth noting for this question. Half of the participant's responses indicated concern for the two separate chains of command that the Wing Commander must report to. For the AD portion of the organization that reporting chain is up through 18 AF and ultimately AMC while the AFRC side reports up through 4 AF and AFRC. The concern is that there are still two potentially competing interests for the organizations. Participants did acknowledge that even though there are two different "masters" to be served in the reporting chain, they felt better off as this burden is now

shouldered by the Wing Commander and not by the individual Squadron Commanders.

**Has the I-Wing concept, as utilized at Seymour Johnson AFB, NC, proven to be successful thus far?**

The participants overwhelmingly felt that the I-Wing Pilot Program has been quite successful thus far. The I-Wing leadership gave supporting data for inspections and other measures that indicate the successes the organization has experienced thus far.

**What, if any, insurmountable obstacles exist for the integrated unit construct?**

The participants indicated, in an overwhelming fashion, that there were or are no insurmountable obstacles for the I-Wing Pilot Program. This response is good to hear, however, the researcher recommends caution on this response. It is possible that the participants are willing to overlook some issues and concerns knowing that their people, their airmen, will do whatever it takes to get the mission done. This attitude has the potential to allow issues to remain and not be solved properly at the appropriate levels.

**Questions without emergent themes:**

**Have any other unexpected issues surfaced?**

**What actions have been taken to remove any duplication?**

**What savings have and/or will be realized due to the effort?**

**What are your thoughts on OPDIR and how effective it has been?**

**How has OPCON been impacted during the transition?**

**Have there been noticeable changes? If so, how do you feel about these changes? Do they enhance or detract from the Wing's mission?**

**Can you discuss unity of command, any successes and challenges, experienced so far?**

**What obstacles, if any, remain for an integrated chain of command?**

## **Notable Considerations**

The researcher has determined that there are recommendation items of note in The Commission Report that help to further the conversation. As laid out in the PGL and contrasted against the intended recommendations by The Commission, the I-Wing Pilot Program is not a final answer or solution to a single, integrated chain of command. In order for the realization of this to happen, some other items within The Commission Report, as well legal statute modifications, must happen in order to fully realize a single and integrated chain of command. Additionally, some items must be addressed that will ensure the most important part of an organization is addressed, the people.

Recommendation #16: Awards, Decorations, and Promotions: The integrated chain of command must take special care in managing personnel issues such as awards and decorations, promotions, and assignment opportunities, both for those who seek to compete for increasingly higher levels of responsibility and for those who opt to sustain longevity in exercising and developing a particular skill set (United States, National Commission on the Structure of the Air Force, 2014).

--This is important to ensure that we develop leaders that are prepared to lead in their respective components. In addition, this recommendation is important if the Air Force desires to have properly prepared, trained and appropriately knowledgeable airmen than can lead across components.

Recommendation #13: DOC Statements: The Air Force should discontinue the practice of separate designated operational capability (DOC) documents for Active and Reserve units of the same type and place the i-Units under single DOC statements. An initial I-Wing pilot program should be conducted at an associate wing that has already

established a record of success (United States, National Commission on the Structure of the Air Force, 2014).

--This recommendation was not adhered to or instituted with the I-Wing Pilot Project. One reason for lack of implementation is due to the requirement to have parallel organizational structures. The parallel organizational structures require separate UMDs to accompany separate PAS codes for each organization.

Recommendation #34: Integrated Personnel Management: The Air Force should unify personnel management for all three components under a single integrated organization (A1) in the Headquarters Air Staff. This is a different concept than an office that would oversee and integrate the activities of three separate component A1s. The Air Force should aggressively implement the “3 to 1” process but widen and amplify the effort to include integration of the three components’ personnel management processes for such matter as recruiting, assignments, force development, and force management. A unified personnel management organization could best manage the portfolio of Air Force Specialty Codes and achieve the most favorable utilization rates, retention rates, and human capital cost controls (United States, National Commission on the Structure of the Air Force, 2014).

--Until the USAF is willing to make drastic overhauls to its personnel system across all of its components, there will always remain barriers to realizing a single, integrated chain of command for an integrated unit. There has been work done on this front, but as of the timing of this research, there still remains separate systems and processes for each personnel system. To be clear, AFRC maintains its personnel system or Air Force Reserve Personnel Center (ARPC) at Buckley AFB, CO while the USAF Active Component maintains its personnel system and support structure and manning at Air Force Personnel Center (AFPC) at Randolph AFB, TX. This requires maintaining dual infrastructures and

the required resources and personnel to support each organization. It would be valuable to see data that shows what the supporting resources and personnel would be required to support a combined organization in a single location.

## **Summary**

The I-Wing Pilot Program and the timing to get it established and fully operational in and of itself is a monumental task. USAF leadership felt it would be easier if completed at a base that could quickly absorb and adapt to the challenges that such an undertaking would present. This research was intended explore the I-Wing Pilot Program and provide insights and recommendations that might help guide future considerations and potential successes.

After thorough research and analysis of participant responses, the researcher has determined that it is safe to say that the I-Wing Pilot Program is progressing towards the stated goal. It is worth noting that the phased plan put forth that established the I-Wing program is designed to be an exploratory program. If the TF-C office and USAF leadership determines that there is no value in proceeding, the program can be canceled and not progressed through any other phases. The research shows that there are challenges that have been experienced at the lower levels but most are surmountable obstacles.

The researcher has determined, from off the record conversations with senior leaders and members of the TF-C office, that a major impediment to success of the I-Wing is policy and legal statutes. There are close to thirty laws or policies that inhibit certain operations for the I-Wing. One such policy is that in order for a reserve component member to command active component airmen, that member has to be on Title 10 orders for at least 90 days prior to assuming G-Series orders. This lead time can be prohibitive to day to day in garrison operations for a wing. If the Air Force further tried to integrate

organizations down to the squadron level it would also create challenges based on this 90 day lead time necessary. The only way that this challenge can be overcome is by changes to the policies and legal statutes. Unfortunately, at this time, the TF-C office has determined that the best course of action moving forward is to manage the I-Wing without seeking changes to policy and legal statutes. This is the primary reasoning for instituting a Dual Hat Commander with parallel wing organizations. This, as stated previously, does not move toward a single, integrated chain of command.

After analysis and comparison to other research regarding the I-Wing Pilot Program and associate units, the research shows that the I-Wing Pilot Program has not fully realized a single, integrated chain of command. Unfortunately, the laws, statutes and regulations do not allow for full integration at this time. Due to the legal limitations imposed at this time, the 916<sup>th</sup> ARW operates by way of multiple Exceptions to Policy (ETP). These ETPs allow for the 916<sup>th</sup> ARW, as well as other cross component associations, to operate without changing and/or in other cases breaking the law. In order for the I-Wing Pilot Program or any similar program to fully realize a single, integrated chain of command, laws and statutes will need to be challenged and changed. Until then, there will be a reliance on ETPs.

To better function with cross-component organizations across the USAF, based on legal limitations and utilizing the ETP process, the researcher recommends that a collective and streamlined process be sorted out. At this time, there are no collective repositories for ETPs across the USAF at the wing level. For example, the 916<sup>th</sup> ARW might have an ETP that can be utilized by another cross component organization. The only way the other organization would know and realize that an ETP for that specific situation exist is by someone familiar with the ETP at the 916<sup>th</sup> ARW. A better way forward might involve

having wing level ETPs shared across NAFs and MAJCOMs that would enable streamlining and replication of processes already in use. This is essential until the laws and statutes are adjusted accordingly for cross component associations.

The I-Wing Pilot Program utilizes a Dual Hat Commander with parallel organizations to circumvent this challenge. The result is that organizations that belong to two different components are able to co-exist with one person wearing two different Wing Commander Hats, simultaneously. This ensures that the units, and more importantly, the unit members are not out of sight, out of mind and forgotten about. This structure also helps to ensure the members are given opportunities to be professionally developed through the wing level. This construct has the potential to capture the best in our Total Force airmen and enable associations, given the legal constraints, to better contribute to the overall success of the US Air Force.

## **V. Conclusions and Recommendations**

### **Chapter Overview**

This chapter examines the conclusions and significance of the research accomplished for this project. Additionally, recommendations for future research associated with this project will be made.

### **Conclusions of Research and Recommendations for Action**

The research gathered for this exploratory study, although limited in scope, show areas where the I-Wing Pilot Program has brought about improvements in cross-component associations. The research shows that there have been more positive outcomes than negative outcomes. If following the motto of do no harm and leave an organization better than you found it, then it would be appropriate to say that so far, given the data collected by the researcher, no harm has been done and so far the 916<sup>th</sup> ARW is better than it was prior to the I-Wing Pilot Program.

The active duty squadron leadership and other leaders throughout the wing agree that the active duty squadron has seen a notable improvement by having wing and group level leadership locally instead of far removed from the unit they are designed to serve and support. This colocation dismisses the idea of out of sight, out of mind concerns for 911<sup>th</sup> ARS members. Having wing-level leadership on the same installation also allows for opportunities for members from the squadron to gain valuable professional development opportunities that would not have been otherwise afforded to them with the previous set-up having their parent wing in Florida while living and operating in North Carolina.

Many articles point to the Chief of Staff of the Air Force as well as the Secretary of the Air Force having Total Force Integration as a top item of interest and priority. This interest and priority appeared clear in the establishment of the I-Wing Pilot Program and

the desire to implement and execute an exploratory program in a swift manner. This research has shown that there are positive impacts thus far, but of course more time is needed to explore how to best exploit this concept. With the resignation of the previous SecAF along with the appointment of a new SecAF, continued exploration and success of the I-Wing Pilot Program will be determined by how much interest the new SecAF will take in the I-Wing Pilot Program. The TF-C office continues to work to evaluate the best options for force mix, force posture as well as cross-component associations. So far, the research shows that the I-Wing Pilot Program provides some opportunity to better leverage our forces and components. As noted by the research, there are still some laws and statutes that are an impediment to certain areas and opportunities for success as it pertains to the I-Wing. It is imperative that the TF-C team continue to explore and exploit opportunities to mold the I-Wing Pilot Program in a way that will contribute to the overall mission and success of the USAF.

As it stands, there is no single, integrated chain of command across components. The I-Wing Pilot Program has a Dual Hat Commander but continues to have separate chains of command. In order to move towards this desired end state, changes to 10 U.S. Code § 10174 will have to be made that would allow for CONUS Reserve Component forces to be assigned to a MAJCOM other than Special Operations Command or AFRC. As long as these legal restrictions and constraints are in place and are not challenged or changed, there will be significant limitations to a single, integrated chain of command.

Similar to the recommendation for a central repository for Exceptions to Policy, it is recommended that there be a central repository for Memorandum of Agreements necessary to create synergies and exploit the I-Wing. Without a central repository for MOAs, it is possible that key lessons learned and key enabling factors for success of the 916<sup>th</sup> ARW in

coordination with AMC, AFRC and ACC as the host wing will be absent. Without the key lessons learned, it is possible that the I-Wing Pilot Program will not progress to Phase III and beyond.

### **Significance of Research**

Making changes to any bureaucratic organization creates challenges and potentially confusion. The research has shown that from a holistic perspective the I-Wing Pilot Program has proven to have moved in the in the appropriate direction based on recommendations from The Commission. Although, according to bureaucratic management theory, the 916<sup>th</sup> ARW does not have a single established line of authority, creating some confusion, there is not chaos happening within the organization.

The National Commission on the Structure of the Air Force set out to help move the Air Force toward a more cohesive and efficient force structure. The forty-two recommendations were designed to form a “coherent, cohesive, and achievable” concept that would be implemented in tandem. The current structure, as is, has various elements of the forty-two recommendations, some with great success, while other recommendations have been bypassed. This significantly reduces the efficiency and effectiveness of the I-Wing, as it was intended by The Commission. In order to realize significant impact and true total force integration, along with total force management, more effort towards implementing additional recommendations as well as changes to laws and statutes is necessary.

### **Recommendations for Future Research**

The research leads the researcher to recommend exploring additional items that will lead towards true, effective and efficient total force integration. Below are listed items that are recommended for future research.

- Recommend further exploration of a Total Force, integrated Support Squadron with full access to both Active and Reserve Component personnel systems.
- Recommend further exploration of a Total Force integrated Operations Squadron with a Dual Hat Commander.
- Recommend exploration of a comparison of AFRC AFSOC forces assigned to SOCOM versus AFRC and can/should this model be replicated by AFRC units for unity of effort and unity of command.
- Recommend further exploration of changes to statutes that govern command of AFRC forces.
- Recommend exploration of a repository of Exception to Policy letters as well as repository of Memorandums of Agreement to be maintained in manner visible and easily accessible from NAF level all the way down to Squadron level to enable synergies and efficiencies to be gained by Total Force Integration.

## **Summary**

The Commission has given forty-two recommendations that are designed to allow the Air Force to maximize efficiencies in personnel and resources. So far, with the implementation of the I-Wing Pilot Program, progress is being made. It is possible that the time allotted for change and improvements is not adequate given the level of complexities realized with the 926<sup>th</sup> ARW. The I-Wing Pilot Program is an exploratory program that has lots of unrealized potential. It is imperative that the lessons learned thus far be captured and capitalized moving forward. It is also necessary that additional recommendations, accepted by the Air Force, be implemented in a methodical way that allows for efficiencies and effectiveness in Unity of Command and Unity of Effort. Our nation and the future of the Air Force depends on maximizing our precious resources and personnel.



# Total Force Integration: The I-Wing Pilot Program at SJAFB, NC



## Introduction

The USAF has had Associate units since 1968. Since that time, the USAF has sought ways to better integrate across components to create a more cohesive, interchangeable, structured Air Force. Total Force Integration or TFI is the common term used for these interchangeable force structures.

The USAF established a Total Force Continuum office within the HAF in order to better manage these associations as well as explore better ways to integrate across components while maximizing effectiveness and efficiencies.

The 2014 NCSAF stated "Classic and Active associate units have not achieved their full potential because they continue to maintain dual chains of command..." The Commission set out to address USAF challenges with current inventory and manning while continuing to satisfy the national security mission.

The research was exploratory in nature to see the current successes and challenges of the I-Wing Pilot Program.

## Implications

Total Force units are the way forward for the USAF in a resource and personnel constrained environment. It is imperative that methods to deal with excess infrastructure and limited manpower are explored and implemented soonest.

The I-Wing has the potential to leverage manpower, resources and bases in order to allow the force to be agile, efficient and effective in the employment of Air, Space and Cyber power globally.

The USAF will continue to rely more and more on its ANIC and AFRC forces. Learning lessons with the I-Wing Pilot Program will enable synergy along with efficiency and effectiveness in garrison, thereby allowing forces to be employed by CCDR globally.

Maj Jason O. Harris

Advisor: Lt Col Jason R. Anderson, PhD

Advanced Study of Air Mobility (ENS)

Air Force Institute of Technology

## Analysis, Conclusions, and Recommendations

### 1. Unity of Command

a. A Dual-Hat Commander with parallel wing structures, one for Active and Reserve Component, respectively; b. Congressional and legal statutes limit full integration into single organization with single, integrated chain of command;

c. Full members from each component require adherence to guidance from separate NAF and MAJCOM command structures;

### 2. I-Wing Pilot Program Issues & Challenges:

a. P-Plan not complete prior to initiation of I-Wing Pilot Program;

b. FIOC should be scheduled at least one year from publication of P-Plan;

c. Major administrative barriers continue to exist, contrary to The Commission's recommendations;

d. Access to personnel systems has been an impediment to success;

e. Duplicative processes unable to be identified and addressed due to separate MAJCOM reporting requirements;

f. Cross component access must be implemented, which will require education, training and trust;

g. Overall, I-Wing has been a success thus far.

### 3. Notable Considerations

a. Many more commission recommendations should be explored for prompt implementation

b. Recommendation #34, Integrated Personnel Management continues to be worked at the HAF level. Until this challenge is solved, there will continue to be barriers towards realizing single, integrated chain of command.

## Methodology

Exploratory research was used to conduct this research. The intent was to provide priorities and considerations for further follow on research. Additionally, exploratory research is not designed to provide definitive conclusions. Ultimately, the research was designed to provide awareness of the issues and challenges at hand.

A questionnaire was used to explore the issues using participants from the I-Wing Pilot Program. Questions were open ended questions intended to gather as much data as possible. The data was evaluated using simple thematic analysis.

## Future Research

- Recommend further exploration of a Total Force, Integrated Support Squadron with full access to both Active and Reserve Component personnel systems.
- Recommend further exploration of a Total Force Integrated Operations Squadron with a Dual Hat Commander.
- Recommend exploration of a comparison of AFRC AFSOC forces assigned to SOCOM versus AFRC and can/should this model be replicated by AFRC units for unity of effort and unity of command.
- Recommend further exploration of changes to statutes that govern command of AFRC forces.

- Recommend exploration of a repository of Memorandums of Agreement to be maintained in manner visible and easily accessible from NAF level all the way down to Squadron level to enable synergies and efficiencies to be gained by Total Force Integration.



AIR FORCE INSTITUTE  
OF TECHNOLOGY



## **Appendix B. Questionnaire**

### **Central Questions**

**What is the root-cause for the I-Wing pilot program delay?**

**What actions can be taken to facilitate a timely Integrated Wing transition?**

**Are we on track to meet the timing and goals to transition between all four phases of the Program Guidance Letter (PGL) L16-01?**

**What can be done to facilitate the administrative challenges during the I-Wing transition?**

### **Demographic Questions**

1. What is your organization's manning strength at (percentage)?
2. What metrics does your unit use to gauge readiness? Have those metrics changed during the transition?

### **I-Wing Structure**

3. Can you tell me about/could you describe in as much detail as possible the I-Wing concept and how Seymour Johnson AFB, NC is integrating the construct?
4. What challenges were expected during the transition during Phase 2, pilot program?
5. Have any other unexpected issues surfaced?
6. What successes were expected during the transition?
7. Have there been any other unexpected successes?
8. What actions, in Phase 2, must occur to enable the transition to Phase 3?
9. Where do you perceive there to be bottlenecks in Phase 2 which may delay the transition to Phase 3?
10. What processes, facilities, personnel, or costs have been identified as duplicative in the process thus far?
11. What actions have been taken to remove any duplication?
12. What savings have and/or will be realized due to the effort?

### **OPCON**

13. What are your thoughts on OPDIR and how effective it has been?
14. How has OPCON been impacted during the transition?

### **ADCON**

15. How has admin support and control been impacted by the I-Wing transition?

16. Have there been noticeable changes? If so, how do you feel about these changes? Do they enhance or detract from the Wing's mission?
17. How have administrative processes been impacted during the transition, positively or negatively?

### **Unity of Command**

18. Can you discuss unity of command, any successes and challenges, experienced so far?
19. Has progress been made toward an integrated chain of command? Why or why not?
20. What obstacles, if any, remain for an integrated chain of command?
21. What positive and/or negative impacts has the dual-hat structure of RegAF/AFRC structure had?

### **Closing Questions**

22. Has the I-Wing concept, as utilized at Seymour Johnson AFB, NC, proven to be successful thus far?
23. What, if any, insurmountable obstacles exist for the integrated unit construct?

## Bibliography

- Bernard, H. R. (2006). *Research Methods in Anthropology: Qualitative and Quantitative Approaches (4th ed.)*. New York: Rowan and Littlefield.
- Braun, V., & Clarke, V. (2006). Using Thematic Analysis in Psychology. In *Qualitative Research in Psychology*, 3 (2) (pp. 77-101). University of The West of England.
- Cantwell, G. T. (1997). *Citizen Airmen: A History of the Air Force Reserve, 1946-1994*. Washington, D.C.: U.S. Government Printing Office.
- Castillo-Montoya, M. (2016). Preparing for interview research: The interview protocol refinement framework. *The Qualitative Report*, 21(5), pp. 811-831.
- Dewey, J. (2013). *Logic: The Theory of Inquiry*. Read Books.
- HQ USAF. (2016). *Program Guidance Letter (PGL) L16-01, United States Air Force Integrated Wing Program Guidance Letter*. Washington, D.C.: U.S. Air Force.
- Kumar, S., & Singh, S. (2011). *Business Research Methods*. Bangalore: Thakkur Publishers.
- Pohlsander, R. (2016). *Integrated-Wing Overview*. Headquarters Air Force (HAF).
- Shields, P. M., & Rangarajan, N. (2013). *A Playbook for Research Methods: Integrating Conceptual Frameworks and Project Management*. New Forums Press.
- Shields, P. M., & Tajalli, H. (2006). Intermediate Theory: The Missing Link in Successful Student Scholarship. *Journal of Public Affairs Education*, 313-334.
- U.S. Air Force. (2006). *Air Force Policy Directive (AFPD) 90-10, Command Policy: Total Force Integration Policy*. U.S. Air Force.
- U.S. Air Force. (2011). *Air Force Basic Doctrine, Organization, and Command*. U.S. Air Force.
- U.S. Air Force. (2017). *Air Force Instruction (AFI), 90-1001, Special Management: Planning Total Force Associations (TFAS)*. U.S. Air Force.

U.S. Joint Chiefs of Staff. (2014). *Joint Publication 3-0: Joint Operations, Annex 3-30*. U.S. Department of Defense.

U.S. Joint Chiefs of Staff. (2016). *Joint Publication 1-0: Joint Personnel Support*. Department of Defense.

U.S. Joint Chiefs of Staff. (2017, January 17). *Joint Publication 3-0: Joint Operations*. Department of Defense. Retrieved from [www.dtic.mil/doctrine/new\\_pubs/jp3\\_0.pdf](http://www.dtic.mil/doctrine/new_pubs/jp3_0.pdf)

United States, National Commission on the Structure of the Air Force. (2014). *National Commission on the Structure of the Air Force: Report to the President and the Congress of the United States*. Arlington: United States Government.

Weber, M. (1946). Bureaucracy. In M. Weber, *Essays In Sociology* (pp. 196, 232-235).

Weber, M. (1983). *Max Weber on Capitalism, Bureaucracy, and Religion: A Selection of Texts*. Allen & Unwin Australia.

# REPORT DOCUMENTATION PAGE

*Form Approved*  
*OMB No. 0704-0188*

Public reporting burden for this collection of information is estimated to average 1 hour per response, including the time for reviewing instructions, searching existing data sources, gathering and maintaining the data needed, and completing and reviewing this collection of information. Send comments regarding this burden estimate or any other aspect of this collection of information, including suggestions for reducing this burden to Department of Defense, Washington Headquarters Services, Directorate for Information Operations and Reports (0704-0188), 1215 Jefferson Davis Highway, Suite 1204, Arlington, VA 22202-4302. Respondents should be aware that notwithstanding any other provision of law, no person shall be subject to any penalty for failing to comply with a collection of information if it does not display a currently valid OMB control number. **PLEASE DO NOT RETURN YOUR FORM TO THE ABOVE ADDRESS.**

<b>1. REPORT DATE (DD-MM-YYYY)</b> 15-06-2017		<b>2. REPORT TYPE</b> GRP		<b>3. DATES COVERED (From - To)</b> May 2016 - Jun 2017	
<b>4. TITLE AND SUBTITLE</b>  Total Force Integration: A look at the Integrated Wing Pilot Program				<b>5a. CONTRACT NUMBER</b>	
				<b>5b. GRANT NUMBER</b>	
				<b>5c. PROGRAM ELEMENT NUMBER</b>	
<b>6. AUTHOR(S)</b>  Harris, Jason O., Major, USAF				<b>5d. PROJECT NUMBER</b>	
				<b>5e. TASK NUMBER</b>	
				<b>5f. WORK UNIT NUMBER</b>	
<b>7. PERFORMING ORGANIZATION NAME(S) AND ADDRESS(ES)</b>  Graduate School of Engineering and Management (AFIT/EN) 2950 Hobson Way Wright-Patterson AFB, OH 45433-7765				<b>8. PERFORMING ORGANIZATION REPORT NUMBER</b>  AFIT-ENS-MS-17-J-030	
<b>9. SPONSORING / MONITORING AGENCY NAME(S) AND ADDRESS(ES)</b> James P. Scanlan, Maj Gen, USAF Mobilization Assistant to the Commander HQ Air Force Special Operations Command Hurlburt Field, FL 32544				<b>10. SPONSOR/MONITOR'S ACRONYM(S)</b> AFSOC	
				<b>11. SPONSOR/MONITOR'S REPORT NUMBER(S)</b>	
<b>12. DISTRIBUTION / AVAILABILITY STATEMENT</b>  Distribution Statement A. Approved for Public Release; Distribution Unlimited					
<b>13. SUPPLEMENTARY NOTES</b> This work is declared a work of the U.S. Government and is not subject to copyright protection in the United States.					
<b>14. ABSTRACT</b> This graduate research paper takes an exploratory examination of the Total Force Integration by way of the Integrated Wing (I-Wing) Pilot Program at Seymour-Johnson AFB, NC. The exploratory research examines the challenges and possible solutions to ARC and USAF ability to plan, generate, and execute missions in a total force environment. More specifically, this paper takes an exploratory look at the National Commission on the Structure of the Air Force (NCSAF) and the new I-Wing Pilot Program recently stood up at Seymour-Johnson Air Force Base, NC. This new structure, a result of the 2014 NCSAF and guidance from the Chief of Staff of the Air Force and the Secretary of the Air Force, has the potential to create opportunities for synergistic gains and efficiencies among the Air Force components. This paper will explore areas and opportunities for synergy with an emphasis on the administration (ADCON) and Operational (OPCON) challenges.					
<b>15. SUBJECT TERMS</b> I-Wing, AFRC, Seymour-Johnson AFB					
<b>16. SECURITY CLASSIFICATION OF:</b>			<b>17. LIMITATION OF ABSTRACT</b>  UU	<b>18. NUMBER OF PAGES</b>  69	<b>19a. NAME OF RESPONSIBLE PERSON</b> Lt Col Jason R. Anderson
<b>a. REPORT</b> U	<b>b. ABSTRACT</b> U	<b>c. THIS PAGE</b> U			<b>19b. TELEPHONE NUMBER (include area code)</b> 937-255-3636