



Reimagining the Character of Urban Operations for the U.S. Army

How the Past Can Inform the Present
and Future

Gian Gentile, David E. Johnson, Lisa Saum-Manning,
Raphael S. Cohen, Shara Williams, Carrie Lee, Michael Shurkin,
Brenna Allen, Sarah Soliman, James L. Doty III

For more information on this publication, visit www.rand.org/t/RR1602

Library of Congress Cataloging-in-Publication Data is available for this publication.

ISBN: 978-0-8330-9607-4

Published by the RAND Corporation, Santa Monica, Calif.

© Copyright 2017 RAND Corporation

R® is a registered trademark.

Limited Print and Electronic Distribution Rights

This document and trademark(s) contained herein are protected by law. This representation of RAND intellectual property is provided for noncommercial use only. Unauthorized posting of this publication online is prohibited. Permission is given to duplicate this document for personal use only, as long as it is unaltered and complete. Permission is required from RAND to reproduce, or reuse in another form, any of its research documents for commercial use. For information on reprint and linking permissions, please visit www.rand.org/pubs/permissions.

The RAND Corporation is a research organization that develops solutions to public policy challenges to help make communities throughout the world safer and more secure, healthier and more prosperous. RAND is nonprofit, nonpartisan, and committed to the public interest.

RAND's publications do not necessarily reflect the opinions of its research clients and sponsors.

Support RAND

Make a tax-deductible charitable contribution at

www.rand.org/giving/contribute

www.rand.org

Preface

The history of human conflict suggests that the U.S. Army will likely be fighting somewhere in the world in the not-too-distant future. The rise of urbanization – and all of the complexity it entails – increases the likelihood that at least some future conflicts will take place in cities. Enemies of the United States will move to urban areas where they can evade American long-range strike capabilities and establish bases for their own operations. A deeper understanding of the challenges and opportunities that exist within the confines of the city landscape can help reduce the magnitude of the challenges associated with an urban environment to the point where military forces can exploit (rather than be *exploited by*) local nuances to operational effect. Indeed, in urban warfare, the local drivers of conflict, the tactical firing positions of urban dwellings, the will of the civilian population, or the neighborhood itself can become the Army force’s greatest ally or worst foe.

To help the U.S. Army prepare to fight in urban terrain, RAND conducted a historical analysis of the ways in which militaries have deployed light and mechanized infantry during close urban combat. The objective was to examine the comparative advantages and costs of this warfighting approach and to identify the lessons that might be gleaned from these experiences. The study brings into sharp relief how different military approaches have managed to shrink the problems inherent to urban combat down to dimensions that are solvable with the capabilities of the available force. Such lessons can inform how the U.S. military might confront similar foes in complex, urban environments in the future.

The report should interest a wide group of U.S. Army, U.S. Marine Corps, and other defense personnel involved in planning and executing combined arms operations within the complex terrain of the urban environment.

This research was sponsored by the Deputy Chief of Staff G-2, U.S. Army Training and Doctrine Command, and conducted within RAND Arroyo Center's Forces and Logistics Program. RAND Arroyo Center, part of the RAND Corporation, is a federally funded research and development center sponsored by the United States Army.

The Project Unique Identification Code (PUIC) for the project that produced this document is HQD156879.

Executive Summary

The nature of the battlefield is as complex as the enemies within it, and some call into question whether mechanized, armored forces are an effective tool in every combat situation. Urban environments in particular pose significant challenges for mechanized infantry assault forces, and their employment in the city landscape has traditionally been avoided when at all possible. However, even though some military professionals have underestimated the value of armored and mechanized forces in urban operations, history and recent combat experience have repeatedly demonstrated the need for these kinds of forces in urban operations. The rise of urbanization makes instability and conflict within dense population centers a very real possibility, and U.S. Army forces may be drawn into urban environments to eradicate enemy forces or otherwise bring stability to a crisis situation.

To gain an appreciation for what the Army may confront in the future, RAND conducted a historical analysis of the ways in which militaries have deployed light and mechanized infantry with armored forces during close urban combat. The objective was to identify the comparative advantages and disadvantages of employing light and mechanized infantry in urban combat. Findings suggest that when light and mechanized infantry along with armor forces cooperate as effective combined arms teams, they can adapt and apply creativity to produce a decisive effect on urban combat operations. This comparative analysis of previous urban combat operations involving light infantry and mechanized infantry forces provides insights into what the Army needs in terms of change and transformation to carry out urban operations effectively in the future.

Contents

Preface	iii
Executive Summary	v
Summary	ix
Acknowledgments	xv
CHAPTER ONE	
Introduction	1
Urban Operations: Past, Present, and Future.....	1
Purpose	5
Organization.....	6
CHAPTER TWO	
The Character of Future Urban Operations	7
The Future Urban Environment.....	8
What Do You Need to Know About the City?	16
Which Cities Matter, and How Do You Know?	18
CHAPTER THREE	
Shrinking the Problem or Not: Lessons from Four Urban Combat Operations	21
U.S. and Other UN Military Forces in Mogadishu, 1993	22
Russians in Grozny, 1994–1996, 1999–2000	28
3ID Armored Raids on Baghdad, April 5 and 7, 2003.....	40
4ID in Sadr City, 2008	45
Key Insights and Findings from Case Studies	58

Understanding the Past Through the Prism of the Present: Current
Russian Combat Operations in Ukraine..... 60

CHAPTER FOUR

**Striking the Right Balance: A Comparative Analysis of Light and
Mechanized Infantry in the Second Battle of Fallujah** 65

Introduction to Comparative Analysis.....65

Fallujah: Battle Narrative67

Fallujah II: Analytical Trends-Based Casualty Data..... 86

Adaptation and Imaginative Thinking in Fallujah II 92

CHAPTER FIVE

**A Comparison of Approaches in Different Urban Population
Settings**119

CHAPTER SIX

The Central Role of Intelligence in Future Urban Combat..... 125

Three Trends for Intelligence in Urban Operations 125

The Intelligence Disciplines in the Future Urban Warfare 133

Expanding Intelligence Capacity for Urban Warfare147

Conclusion 150

CHAPTER SEVEN

Operations in Urban Areas: Implications for the Army151

Operations in Urban Areas: Implications for Warfighting Challenges... 151

Operations in Urban Areas: Implications for DOTMLPF-P 160

Conclusion174

Lists of Figures and Tables..... 177

Abbreviations179

Bibliography 183

Summary

Background

Lieutenant General H.R. McMaster (et al.) recently commented that armored, mechanized infantry forces

have been invaluable on the battlefield. Thanks to their speed, protection, and firepower, along with their ability to work in concert with many other types of ground forces, armored forces have played crucial roles in defeating enemy militaries, toppling hostile regimes, fighting insurgents, and establishing security.¹

The nature of the battlefield is as complex as the enemies within it. Urban environments in particular – with dense populations, narrow streets, subterranean passages, and multistory buildings that serve as enemy defensive positions – pose significant challenges for mechanized infantry assault forces and have traditionally been avoided when at all possible. In the decade following the end of the Cold War, American military planners began to appreciate the growing relevance of large urban areas around the world as potential sources of instability and conflict and as potential safe havens for a wide variety of enemy forces. Cities are often also the center of gravity for establishing governance and local control. As a result, militaries have been drawn into urban landscapes on numerous occasions, sometimes to great effect and sometimes not. History shows that, contrary to some views about

¹Chris McKinley, Mark Elfendahl, and H. R. McMaster, “Why the U.S. Army Needs Armor,” *Foreign Affairs*, May–June 2013.

the inability of mechanized and armored forces able to operate in complex urban terrain, in fact such forces have become quite critical for operational success against a determined foe.

Purpose and Approach

RAND conducted a historical analysis of the ways in which militaries have deployed light and mechanized infantry during close urban combat. The objective was to identify the comparative advantages and costs of this warfighting approach and to distill the lessons that might be gleaned from these experiences. These lessons can also inform how the Army might confront similar foes in complex, urban environments in the future.

Five case studies lie at the analytic heart of this report. The case studies include both successes and failures, and they contain a wealth of lessons. The case studies are the U.S. Army in Mogadishu in 1993, the Russian Army in Grozny in 1994 and in 1999, the U.S. Army in Baghdad in 2003, the U.S. Marine Corps and U.S. Army in Fallujah in 2004, the U.S. Army in the Sadr City suburb of Baghdad in 2008, and the U.S. Marines and U.S. Army in Fallujah in 2004. While these battles differ considerably in the conduct and outcomes, all provide a trove of lessons of import for how the U.S. Army organizes and trains for urban combat.

These case studies also highlight the need to improve situational awareness in densely populated urban environments through enhanced intelligence exploitation that harnesses technological advances for operational effect. These observations, among many more explored throughout this study, have significant implications for U.S. Army requirements across its doctrine, organizations, training, materiel, leadership, personnel, and facilities (DOTMLPF).

What We Found

Several common themes emerge from the analysis of the five case studies.

Having Mobile Protected Firepower When Conducting Urban Operations Is a Necessity

All combat is dangerous, but urban combat is especially so. Typically, the enemy is fighting on his home terrain and knows which routes of advance are restricted. Protected fighting positions for defenders are abundant, and engagement ranges are typically short. Stand-off weapons can be used, but ground forces must first develop the situation so those weapons can be applied with good effect. In other words, troops need armored protection. But armored vehicles cannot operate in cities without infantry. Thin-skinned vehicles, a category that includes the Army's Stryker and the Russian BMPs, do not survive well in urban combat. The U.S. Army lost six Strykers in its initial forays into Sadr City, and in Tal Afar in 2005 Strykers could not be employed without unacceptable risk. The Russian BMPs routinely fell victim to rocket-propelled grenades (RPGs) in the first battle of Grozny. Even tanks were destroyed in Grozny, with the rebels launching attacks against the tops, sides, and rears of the tanks, where they have less armor. Employed properly, however, mobile, armored vehicles are indispensable.

Forces Need to Be Creative and Adaptive and Exploit Intelligence to Operational Effect

Each city poses different challenges, and these are likely to increase in the future as more and more mega-cities (those with upward of 10 million inhabitants) appear. A constant for troops engaged in urban combat is to shrink the problem to a manageable size. But how that shrinking occurs varies considerably depending on the city. In some cases, it may be possible to restrict the enemy to portions of the city, and then deal only with that urban terrain. In the second battle for Grozny, the Russians did substantial intelligence preparation of the battlefield, dividing the city into sectors. They also enlisted Chechen loyalists to help them identify key terrain and provide detailed knowl-

edge of the city. The Russians then surrounded the rebel Chechen enclave with armored forces and used them to eliminate strongpoints. The encirclement made it difficult for the Chechen rebels to resupply by slipping out of the city. In the battle for Sadr City, U.S. forces changed the terms of the battlefield by erecting a 12-foot concrete barrier along a key route, thus denying the Jaish al-Mahdi (JAM) forces firing positions that could range the Green Zone locations of the Iraqi and U.S. government agencies and provide access to the population. In response, JAM forces left their hiding places and engaged U.S. forces on ground of their choosing and using methods that favored them, especially the highly integrated combined operations. In the end, JAM forces lost their advantages and, eventually, the battle.

In Fallujah, U.S. forces informed noncombatants in the city that operations were about to commence, which had the effect of causing the civilian noncombatants of the city to leave. This approach greatly reduced the problem of identifying enemy forces, as well as the problem of having dead and wounded noncombatants show up on the evening news and alienating world opinion. As the battle progressed, less and less terrain was available to the insurgents, further diminishing the challenge. Of course, having noncombatants leave Fallujah was only feasible because of the size of the city and the preparation time available. It would not be possible with larger populations, as the battle for Sadr City, which involved a population of millions, illustrates. The approach in Fallujah had the additional advantage of reducing the amount of collateral damage, not only to the population but to the city as well. The damage where the insurgents were located was, indeed, severe, with several buildings destroyed. But other areas of the city were unscathed. Table S.1 shows the relative effectiveness of various techniques to reduce the scope of the operational problem – or “shrink the problem” – in the case studies conducted; the table’s rationale will be developed in the following chapters.

Table S.1
Comparing Methods to Shrink the Problem

Battle	Using Mobile Protected Fire for Maneuver	Reducing Collateral Damage	Planning and Training for Combined Arms Operations	Knowing the Enemy (Intelligence Preparation of the Battlefield)
Mogadishu	Not successful	Not successful	Not successful	Not successful
Grozny I	Somewhat/ eventually successful	Not successful	Not successful	Not successful
Grozny II	Successful	Successful	Somewhat/ eventually successful	Somewhat/ eventually successful
Baghdad	Successful	Successful	Successful	Somewhat/ eventually successful
Sadr City	Somewhat/ eventually successful	Successful	Successful	Somewhat/ eventually successful
Fallujah II	Successful	Successful	Somewhat/ eventually successful	Somewhat/ eventually successful

NOTE: In the column “Planning and Training for Combined Arms Operations,” the term *combined arms* is defined not only as teaming armored vehicles with infantry but also as combining other arms, such as close air support and indirect fires.

What Urban Combat Implies for the U.S. Army

The implications from the case studies for the Army are profound, both from an offensive and from a defensive perspective. With regard to the former, its experience in Iraq notwithstanding, the Army is not ready to fight in urban combat. Its doctrine, tactics, and training have not absorbed the lessons these case studies teach. In part, this is because urban combat is messy and destructive and seen as something to be avoided. But a central message of this report is that urban combat may not be avoidable. The Army may not want to fight in cities, but it is very likely that some future enemy will dictate the terms of the battle and choose to make the battlefield an urban one to play to his strengths

and mitigate ours. The Army needs to conduct a searching review of the warfighting challenges from an urban combat perspective. Then it needs to modify doctrine, organization, training, materiel, leadership, personnel, and facilities to enable it to respond to the challenges. This will be neither easy nor cheap nor quick. But given that urban combat somewhere is a near certainty, it must be done.

Acknowledgments

We would like to thank Thomas Greco, U.S. Army Training and Doctrine Command (TRADOC) G2, for his vision on the important aspects that this project covers and for his encouragement and support throughout. We owe a debt of gratitude to Colonel Adrian Bogart III for his willingness and ability to get the project rolling in its very early stages. And we thank Anna Donnelly of TRADOC for her expertise in navigating the complexity of the approval process for the project. Thanks also to Kevin Kennedy and Kyle Ebaugh of the Army's Command and General Staff College for allowing us to observe their excellent Fallujah virtual staff ride and for providing us with some hugely helpful graphic charts that explain the battle, which we have used in this report. In the same vein, we thank Matt Matthews for providing us with a trove of primary source evidence.

At RAND, we would like to thank Bruce Held, Terry Kelly, Chris Pernin, and Isaac Porche. We are also grateful to Kyle Bartrem, Bryan Frederick, Lovancy Ingram, David Stebbins, and Zachary Steinborn. We are grateful to RAND colleague Michael Decker and James Carafano from the Heritage Foundation for their reviews and comments. Finally, we thank Martha Friese, Patrice Lester, Lisa Sodders, James Torr, and Todd Duft for their assistance in producing this report.

Introduction

Urban Operations: Past, Present, and Future

The thinking during the Cold War was that if U.S. ground forces had to confront massive Soviet armies in Western Europe, the fighting would be out in the open and away from large cities or urban areas. By the end of the 1990s, nearly a decade after the end of the Cold War, American military planners had begun to realize they could no longer avoid large urban areas around the world, due to their roles as hubs of political, economic, and cultural significance. Doctrine for conducting military operations in urban environments had to, for the most part, jettison previous operational doctrine produced during the Cold War, which had called for bypassing cities altogether.

Then, on September 11, 2001, al Qaeda attacked the World Trade Center in New York City. Within barely two years after that searing event, the U.S. military (mainly the Army and U.S. Marine Corps [USMC]) found itself at war in Iraq and Afghanistan. In the latter, the U.S. Army fought al Qaeda's supporters, the Taliban, largely in the rural farm areas and eastern mountains. In Iraq, however, the U.S. Army and USMC quickly found themselves fighting in Baghdad, Fallujah, Tal Afar, Ramadi, Najaf, and many more.

As of late 2016, five years after the U.S. Army left Iraq and with only a small presence in Afghanistan, the U.S. Army is confronted with the likelihood that it will soon find itself fighting a determined, experienced, and sophisticated foe in either a small or large urban area. The questions, then, are what kinds of wars and conflicts the U.S. Army might become involved in in the years ahead, and what roles the Army

will be expected to perform within the joint force. Three scenarios, although not necessarily likely, are plausible: North Korea, the Baltic states, and northern Iraq.

One very real possibility is the collapse of the North Korean state and an ensuing occupation of North Korea by South Korean forces assisted by the U.S. Army, possibly working in concert with China. One of the purposes of the occupation by South Korea and the United States would be to gain control of the numerous weapons of mass destruction – specifically, North Korea’s most lethal chemical, biological, and, especially, nuclear weapons. Two other purposes would be to establish a new political governing structure in the country and to react to the inevitable humanitarian disaster. In trying to achieve these objectives, the U.S. Army might find that its occupation of the North requires fighting remnants of the old North Korean Army along with pockets of resistance by the North Korean population, who will very likely choose to fight in urban areas, from small villages to larger cities. Although the South Korean Army would most likely enter Pyongyang, the U.S. Army would still face very difficult terrain in North Korea, including urban areas. Those urban areas, combined with high mountains with very narrow valley passages at certain points, would be ideal for remnant North Korean Army defenders, who would possess relatively well-trained infantry with some armored capability, access to indirect fires systems, and large amounts of land mines.

To be sure, remnants of the North Korean military would be limited in their ability to resupply and sustain themselves. However, the simple fact that there is an abundance of military hardware throughout the country means that these pockets of resistance could fight for an extended period of time. A fighting occupation of North Korea by the South Korean military assisted by the U.S. Army on the ground could therefore take months, or even years, to complete and would involve sustained ground operations, not only in the mountainous terrain but also in either small or large North Korean urban areas, with the potential for significant numbers of U.S. casualties. Depending on the actions of the People’s Republic of China during a North Korean collapse, there could be a need to maintain considerable U.S. Army forces in the North to stabilize the situation and protect American

long-term interests. In particular, Republic of Korea forces could not control nuclear weapons or occupy nuclear weapon sites because of their treaty obligations to the Nuclear Non-Proliferation Treaty.¹

Another region of the world of vital strategic interest to the United States is Europe, and a leading security concern today involves the potential for Russian advances into the Baltics. If this happened, it could destabilize the entire region and force a NATO response. Depending on certain U.S. policy decisions made prior to the Russian advance – namely, whether to forward deploy U.S. combat troops into the Baltics – the U.S. Army could find itself either defending against the Russian assault if forward deployed or conducting a major combat operation to evict the Russian military from the Baltics. Current estimates are that the Russian military, spearheaded by a mechanized army ground force, could reach the major Baltic cities, such as Riga, along the coastline from its starting position in approximately 48 hours, depending on the kinds of defenses Russian forces might confront.²

The U.S. Army might find itself in combat operations against the Russian military. If this occurred, the U.S. Army as part of a joint American (and probably allied) force would confront a highly sophisticated opponent in the Russian military. Capable of sophisticated combined arms maneuver using a ground force based on mobile protected firepower along with highly lethal air defense and fire support systems, the Russian military would indeed represent a formidable foe for the U.S. Army. This would not only be the first time the U.S. Army (and Navy and Air Force) experienced high-end, high-casualty-producing combat since the Vietnam War, when it faced the North Vietnamese Army, but also the first time it fought primarily on the defensive and in an urban area. The very likely possibility that, for the first time since the end of World War II, the U.S. Air Force would not be able to gain immediate air superiority would also present significant challenges for

¹ Bruce Bennett, *Preparing for the Possibility of a North Korean Collapse*, Santa Monica, Calif.: RAND Corporation, RR-331-SRF, 2014.

² David A. Shlapak and Michael Johnson, *Reinforcing Deterrence on NATO's Eastern Flank: Wargaming the Defense of the Baltics*, Santa Monica, Calif.: RAND Corporation, RR-1253-A, 2016.

ground combat escalation. Although the Russian Army would most likely prefer to avoid combat operations in Baltic cities such as Riga, the U.S. Army might find it advantageous to mount a defense inside Baltic urban areas.³

Considering actual recent Russian combat operations in Eastern Ukraine that have proven the value of extended range massed artillery fire, active armor protection on armored vehicles, and top-down anti-tank weaponry, a conflict with the Russians in a future urban environment would pose extreme challenges to the U.S. Army in the way it is currently organized and its weapon systems. Indeed, reports emerging from Ukraine show some fundamental shifts in the nature of modern combat. Whereas the U.S. Army and other NATO allies have tilted their organizational structures and fighting doctrine toward an infantry-centric approach, the Russo-Ukrainian war is showing the utility of tanks – albeit tanks outfitted with explosive reactive armor (ERA) – and their extreme overmatch capabilities when pitted against motorized light infantry carried in light armored vehicles.⁴

A third possible future warfighting scenario that the U.S. Army might find itself in at some point in the near future is evicting the Islamic State in Iraq and Syria (ISIS) from northern Iraq. Although doing this is not necessarily a vital interest for the United States, there may be at some point enough political momentum in the United States to do so. If, as President Barack Obama has stated, the “destruction” of ISIS is a U.S. policy goal, it may require a major commitment of American ground combat power and airpower to do so. Although ISIS does not have the sophisticated types of combat systems – mechanized, armored forces; high-end air defenses; artillery delivery systems – that the Russian Army possesses, the fact that ISIS is a disciplined small

³ Terrence K. Kelly, “Stop Putin’s Next Invasion Before It Starts,” *U.S. News & World Report*, March 20, 2015.

⁴ Phillip A. Karber, “Lessons Learned from the Russo-Ukrainian War: Personal Observations,” The Potomac Foundation, July 2015. There is a growing body of literature on urban warfare doctrine of foreign nations; see, for example, C. Christine Fair, *Military Operations in Urban Areas: The Indian Experience*, Santa Monica, Calif.: RAND Corporation, RP-1063, 2003; and Fair’s *Urban Battlefields of South Asia: Lessons Learned from Sri Lanka, India, and Pakistan*, Santa Monica, Calif.: RAND Corporation, MG-210-A, 2004.

unit infantry fighting force with strong command and control (C2) would make it a difficult foe to destroy. To evict ISIS from northern Iraq would require the U.S. Army to enter major urban centers, such as Mosul, and conduct sustained urban combat operations against a light infantry force that would use the urban terrain and the local population to its tactical advantage.⁵

In the years ahead, the U.S. Army may have to confront enemies in places other than the Baltics, North Korea, or northern Iraq. But the pattern of history does show that the Army will be fighting somewhere in the world in the not-too-distant future, and that fighting will be in cities. The Army's future enemies will certainly use urban areas as places to launch long-range strikes against U.S. forces and as a base for their own operations. The U.S. Army today therefore must begin to imagine what combat operations in these environments might be like and further imagine the implications for doctrine, organization, training, materiel, leadership, personnel, and facilities (DOTMLPF).

Purpose

RAND conducted a historical analysis of the ways in which militaries have deployed light and mechanized infantry during close urban combat. The objective was to identify the comparative advantages and costs of this warfighting approach and to distill the lessons that might be gleaned from these experiences. These lessons can also inform how the Army might confront similar foes in complex, urban environments in the future.

This analysis focuses on five case study battles: the U.S. Army in Mogadishu in 1993, the Russian Army in Grozny in 1994 and in 1999, the U.S. Army in Baghdad in 2003, the U.S. Marine Corps and U.S. Army in Fallujah in 2004, and the U.S. Army in the Sadr City suburb of Baghdad in 2008.

⁵ See David E. Johnson, "Means Matter: Competent Ground Forces and the Fight Against ISIS," *War on the Rocks*, March 19, 2015. For analysis on the tactics, techniques, and procedures for groups such as ISIS see Barak Barfi, "The Military Doctrine of the Islamic State: The Limits of Ba'athist Influence," *CTC Sentinel*, March 19, 2016.

Organization

The next chapter characterizes the complex urban landscape to provide a sense of the types of challenges and opportunities specific to such an environment. Chapter Three presents four historical cases and also provides a contemporary example of mechanized forces employment in the Ukrainian-Russo conflict, highlighting how technological innovation can lead to paradigm shifts in the fighting capabilities of the battle tank. Chapter Four offers an in-depth study of urban combat, examining how the USMC and U.S. Army forces fought at the tactical level in Fallujah in 2004. Chapter Five offers a cross-comparison of the different approaches employed in these urban settings and notes that one of the key differences in the battles examined was whether or how much of the population remained in the city during the fight. Chapter Six describes how effective intelligence can maximize the Army's limited resources by decreasing the need to isolate the entire city, just the adversary within it. It discusses some challenges facing the intelligence enterprise and concludes with general recommendations about how to better prepare its workforce for tomorrow's urban operations. Chapter Seven considers how the urban combat landscape might affect U.S. Army warfighting challenges in the future and further imagines the implications for DOTMLPF.

The Character of Future Urban Operations

Since its invasion of Iraq in 2003, the Army has gained a new appreciation for the importance of combat in urban areas. The rationale behind the “Thunder Run” in 2003 and the “Surge” in 2007–2008 during Operation Iraqi Freedom (OIF) centered on controlling Iraq’s capital city, Baghdad, and would have been familiar to Carl von Clausewitz. Indeed, in one of his early works, *Principles of War*, he was unequivocal about the importance of cities in general and capitals in particular: “Public opinion is won through great victories and the occupation of the enemy’s capital.”¹ Beyond capitals, Clausewitz would also have understood the need to take Fallujah in 2004:

In order to seize the enemy’s material forces we should direct our operations against the places where most of these resources are concentrated: principal cities, storehouses, and large fortresses. On the way to these objectives we shall encounter the enemy’s main force or at least a considerable part of it.²

¹ Carl von Clausewitz, *Principles of War*, ed., trans., Hans W. Gatzke, Harrisburg, Pa.: The Military Service Publishing Company, 1942; reprint, Mineola, N.Y.: Dover Publications, 2003, p. 46.

² Clausewitz, 1942, pp. 45–46.

The Future Urban Environment

The implications of global urbanization trends had already been the subject of National Intelligence Council estimates in its *Global Trends* series since 1997, which noted:

Population will increase by 1.2 billion to over 7 billion by 2010. About 95% of this growth will be in developing countries. This growth will also be accompanied by increased urbanization: about half of the world's population will live in cities compared with one-third today. There will be many more mega-cities with populations in excess of 8 million, mostly in developing countries.³

The most recent National Intelligence Council effort, *Global Trends 2030*, sees the urbanization trend continuing, but somewhat differently from its 1997 estimate:

The next two decades' pattern of urban growth will look strikingly different from urban growth patterns of the late 20th century, dynamics that gave rise to most of today's 27 megacities (cities with a population greater than 10 million). Although UN demographers expect this count to continue to rise, these giants will, we believe, become further limited by physical land constraints and burdened by vehicular congestion and costly infrastructural legacies, entrenched criminal networks and political gridlock, and deteriorating sanitation and health conditions. The peri-urban or "rurban" areas will grow faster than city centers, as such areas provide cheaper land for housing and manufacturing. Metropolitan regions will spill over multiple jurisdictions creating mega-regions. By 2030, there will be at least 40 large bi-national and tri-national metro regions.⁴

³ The initial National Intelligence Council report highlighting the issue of urbanization was *Global Trends 2010* (Washington, D.C.: Office of the Director of National Intelligence, 1997).

⁴ National Intelligence Council, *Global Trends 2030: Alternative Worlds*, Washington, D.C.: Office of the Director of National Intelligence, 2012, p. 28. The definition of the population size for a megacity increased by 2 million between the first and latest *Global Trends* reports.

Although urban combat has been a task for militaries throughout the ages, the sheer size of the populations of current and future megacities – and other urban areas that are below the 10 million population criterion – make these types of operations appear more challenging than in the past. Indeed, one of the most storied urban battles in history – the Battle of Stalingrad – took place in a city that had a pre-war population of less than 1 million.⁵ The population of Baghdad during the 2008 Battle of Sadr City was 5,054,000.⁶ Dhaka, Bangladesh, a city one major earthquake away from a humanitarian crisis, has a population of some 15 million and is projected to grow to 22.9 million by 2025.⁷

Population size is one of the characteristics of a megacity, but, as David Kilcullen has pointed out, the megacity reflects “four emerging megatrends of population growth, urbanization, littoralization, and networked connectivity”; furthermore, “these megatrends will affect all aspects of life on the planet in the next 20 to 30 years, not just conflict.”⁸ Cities therefore are the complex urban terrain where humans live and will continue to live, and they are often the locus of

⁵ BBC, “On This Day, 1943: Germans Surrender at Stalingrad,” *BBC News*, February 2, 2016.

⁶ United Nations, Department of Economic and Social Affairs, Statistics Division, *World Statistics Pocketbook 2009*, Series V, No. 34, p. 96.

⁷ The Chief of Staff Army (CSA) Strategic Studies Group (SSG) is in its fourth year. SSG II and III both focused on the issue of megacities. SSG II published an article on its research: Michael Bailey, Robert Dixon, Marc Harris, Daniel Hendrex, Nicholas Melin, and Richard Russo, “A Proposed Framework for Appreciating Megacities: A U.S. Army Perspective,” *Small Wars Journal*, April 21, 2014. Additionally, CSA SSG fellows have written articles on different aspects of operations in a megacity: Richard Russo, “The Gotham Division and SSG Parker,” June 12, 2014; Michael A. Bailey and John D. Via, “Military Medical Implications of Future Megacity Operations,” *Small Wars Journal*, February 13, 2015. Russo’s article imagines the operational, conceptual, and technological possibilities at the division and squad levels that could be available to the Army to operate in a megacity by 2029. See also Kevin M. Felix and Frederick D. Wong, “The Case for Megacities,” *Parameters*, Vol. 45, No. 1, Spring 2015, which discusses megacity challenges, Army efforts to understand them, and several operational approaches.

⁸ David Kilcullen, *Out of the Mountains: The Coming Age of the Urban Guerrilla*, Oxford, UK: Oxford University Press, 2013, p. 17.

political power in a country. Cities are a likely location for instability and conflict.

The Army has also begun seriously studying the implications of operations in urban areas, particularly megacities, since 2013, when General Raymond T. Odierno, then U.S. Army Chief of Staff (CSA), directed operations in urban areas be a focus area for his Strategic Studies Group (SSG).⁹ Additionally, the U.S. Army Training and Doctrine Command (TRADOC) made the megacity challenge part of its Unified Quest Army Chief of Staff's future study plan and hosted the Focused Environment Seminar on February 4-7, 2014, "to explore urban operations in a megacity."¹⁰

TRADOC's *The U.S. Army Operating Concept: Win in a Complex World* shows that the Army understands the implications of urbanization and the potential for conflict in cities:

The percentage of the world's population in urban areas will rise to sixty percent by 2030. Internal migration and higher birth rates contribute to increasing urbanization. Adversaries operate among the people in these urban areas and other complex terrain to avoid U.S. military advantages and they operate in cities because war, as a political phenomenon, is inherently about people. As cities grow, many governments fail to provide adequate security, employment, infrastructure, and services. Armed groups will exploit popular disaffection and weak governance. Urban areas become safe havens and support bases for terrorists, insurgents, or criminal organizations. Urban areas are potential scenes for mass atrocities. Enemies may use cities as launching platforms for long-range missiles that threaten allied as well as U.S. populations. Because urban environments degrade the ability to target threats with precision, joint operations will require land forces capable of operating in congested and restricted urban terrain (to include subsurface, surface, supersurface) to defeat those threats.

⁹ Bailey et al., 2014.

¹⁰ U.S. Army, *The Megacity: Operational Challenges for Force 2025 and Beyond*, Army Chief of Staff's Future Study Plan, Washington, D.C., 2014.

... Operating in urban environments will require decentralized combined arms and joint capabilities.¹¹

The sheer scale of the modern urban operations challenge is daunting, however. Indeed, some have questioned why the Army was even involved in studying megacities. Lexington Institute analyst Daniel Gouré writes:

Proponents of the urban warfare concept like to reference the old Willie Sutton explanation of his habit of robbing banks: “because that’s where the money is.” Except that military operations in megacities would be like trying to rob Fort Knox. Sure there is lots of money in the vaults; but it is a loser’s game. The real question the Army ought to be asking is this: if cities are strategically important, how can we influence and control them without having to go downtown?¹²

Why Go “Downtown”?

The reality is that the Army may have to “go downtown” in urban areas in the future for a multitude of reasons. As the previous quotations suggest, cities are important not only for the people who live in them but also for the governments of the countries in which they reside. They offer potential for people. For the poor, cities offer places to live, even though oftentimes in squalor. Cities offer the potential for wealth accumulation, even though that accumulation may be acquired by only a select few. And since in cities, from small to large, there are huge concentrations of human beings, governments tend to treat them as important entities. Cities also offer the opportunity for individuals and groups to use the urban environment to achieve aims and objectives that can run counter to government authority and can challenge efforts to maintain security and stability in a broader context. The U.S.

¹¹ U.S. Army Training and Doctrine Command, *The U.S. Army Operating Concept: Win in a Complex World*, TRADOC Pamphlet 525-3-1, Fort Eustis, Va., 2014, p. 11.

¹² See Daniel Gouré, “Why Is the Army Planning to Fight in Megacities?” Lexington Institute, May 14, 2014.

Army must think through the implications of the changed and changing urban and megacity challenges before it finds itself in these environments. Critics of the United States' handling of the invasion of Iraq, for example, maintain that it would have been far better to study fighting Baghdad before the invasion of Iraq in 2003, rather than afterward, given that it took some five years to stabilize Baghdad.

While the broad aspects of the implications of the urban environment are understood, what is missing is a framework that can guide the development of concepts and technologies to operate successfully in these complex and challenging environments.

Knowing the Nature of the Conflict You May Be In

The first step in understanding what might have to be done in a megacity is to understand the nature of the conflict: What is the problem the US Army will have to solve or contribute to solving? In his book *Out of the Mountains*, David Kilcullen outlines several scenarios in which conflicts could require military action:

- Humanitarian assistance, disaster relief, or noncombatant evacuation operations . . . that escalate into conflict.
- When governments are giving long-term assistance (sending military advisors, special operations forces, law enforcement support, or civilian development aid) to cities that are experiencing conflict . . . [and] foreign advisors [are] being kidnapped, held for ransom, or used as bargaining chips in local conflicts, and . . . special operations forces [are] having to go in and rescue them.
- Peacekeeping or peace enforcement. . . Even where policy makers' intent is to resolve a conflict, monitor a truce, or police a cease-fire, putting peacekeepers into an urban conflict zone amounts to laying out an attractive array of targets for terrorist groups, local insurgents, street gangs, organized crime, or just commercial kidnapping networks, and this can force peacekeepers into combat at short notice.
- In conventional state-on-state war. . . more or less hypothetical cases of war with China, North Korea, or Iran —

involve urbanized terrain, coastal cities, and constricted littoral sea space.

- Increasingly dense networks of connectivity among cities and populations across the planet, expeditionary operations (where the military goes overseas to fight) may bring retaliatory attacks in home territory – most probably, again, in major cities – that will draw public safety organizations and military forces into lethal situations in urban areas. There have been several instances where members of immigrant communities engaged in attacks against Western cities – either ordered or indirectly inspired by nonstate armed groups in their countries of origin. . . . an increasing threat that we might call “diaspora retaliation.”¹³

These scenarios are accounted for in Army doctrine and operational concepts in what is termed the *range of military operations*, which broadly includes the following:

- military engagement, security cooperation, and deterrence
- crisis response and limited contingency operations
- major operations and campaigns.¹⁴

However, Army urban operations doctrine (FM 3-06, *Urban Operations*) does not discuss important recent urban combat experiences in OIF – most notably the 2004 Battle of Fallujah, urban combat operations in Tal Afar in 2005, and the 2008 Battle of Sadr City (which occurred after the publication of the manual in 2006). These battles offer significant lessons for future urban combat concepts and technologies and are described in more detail later in this report.

The Army document that discusses urban tactics, techniques, and procedures (Army Tactis, Techniques, and Procedures [ATTP] 3-06.11, *Combined Arms Operations in Urban Terrain*), while highly

¹³ Kilcullen, 2013, pp. 265–268.

¹⁴ Army Doctrine Reference Publication (ADRP) 3-0, *Unified Land Operations*, Washington, D.C.: Headquarters, Department of the Army, May 16, 2012, p. 1-6. See also the table on the same page that gives examples of military operations and their doctrinal references. See also U.S. Army Training and Doctrine Command, 2014, p. 16.

detailed, does not contain case studies.¹⁵ Furthermore, the Army doctrine, as it should, discusses how the Army will use its existing tools to operate, rather than what technologies and concepts it needs to develop for the future. Indeed, none of the cases contained in Field Manual (FM) 3-06, *Urban Operations*, approach the complexity and scale of current and future megacities.¹⁶

Joint Publication (JP) 3-06, *Joint Urban Operations*, provides generic descriptions of the urban environment and several operational considerations:

- Cities may reduce the advantages of the technologically superior force;
- Ground operations can become manpower-intensive;
- Operations are time-consuming;
- Combat operations in urban areas may result in large ratios of civilian to military casualties; and
- Operations conducted in urban areas may have more restrictive operational limitations than operations elsewhere.¹⁷

In addition,

Air operations must adapt to the unique urban environment. The urban environment includes challenges such as combat identification, propensity for collateral damage, preservation of infrastructure, restrictive rules of engagement, line of sight obstructions (to include targeting and communications), and freedom of maneuver.

Operations in urban areas may occur within the context of a campaign or major operation. The joint force commander (JFC) will determine whether or not operating in an urban environment is essential for the conduct of the campaign or major opera-

¹⁵ ATP 3-06.11, *Combined Arms Operations in Urban Terrain*, Washington, D.C.: Headquarters, Department of the Army, 2011.

¹⁶ FM 3-06, *Urban Operations*, Washington, D.C.: Headquarters, Department of the Army, October 2006.

¹⁷ JP 3-06, *Joint Urban Operations*, Washington, D.C.: Joint Chiefs of Staff, 2013, pp. vii–viii.

tion and, if so, where and when to conduct joint unified operations (JUOs).¹⁸

JP 3-06 continues by providing the “fundamentals in operations in urban environments,” stating that:

The entire urban environment must be addressed simultaneously and systematically by applying power to disable hostile elements and enable those environmental elements that are essential to the city’s functioning. A comprehensive and systematic approach requires a combination of isolating, protective, improving, sustaining, persuasive, destructive, and disruptive actions or capabilities.¹⁹

Quite simply, in the case of megacities, this prescription for operations may be beyond the capacity of the U.S. military in contested operations. Additionally, this document makes a key assumption that may not hold true in future urban operations:

Moreover, operations in urban terrain will confront joint force commanders with a number of conundrums. The very density of buildings and population will inhibit the use of lethal means, given the potential for collateral damage and large numbers of civilian casualties.²⁰

The 2004 Battle of Fallujah, the Russian battles for Grozny, and the U.S.-Iraqi 2008 Battle of Sadr City were urban operations that show lethal means may be necessary to solve the problem presented by the specific operation. Moreover, when considering the nature of combat in the ongoing Russo-Ukrainian war, even the cases studies of Sadr City and Fallujah have their limits, since American combat forces did not face threat capabilities that are currently on display in eastern Ukraine.

¹⁸ JP 3-06, p. viii.

¹⁹ JP 3-06, p. viii.

²⁰ JP 3-06, p. I-4, quoting “The Joint Operating Environment,” 2010.

What Do You Need to Know About the City?

Army doctrine views intelligence as a means to reduce uncertainty in urban operations: “A thorough IPB [intelligence preparation of the battlespace] of the urban environment can greatly reduce uncertainty and contribute to mission success.”²¹ Similarly, JP 3-06 advocates a joint intelligence preparation of the operational environment (JIPOE) based on a “systems perspective” to attain “a holistic view that extends beyond the adversary’s military forces and other combat capabilities within the operational area.”²² Factors for consideration include political, economic, special social and cultural considerations, information considerations, infrastructure considerations, and “other considerations: (physical factors, history, urban patterns and rhythms, climate, weather, and water).”²³ Also, joint and Army doctrine imply that this effort begins once planning for a specific operation has commenced and that the entire megacity or other large urban area should be “understood” in order for the operate to succeed. Finally, a systems approach implies that megacities share some similar characteristics, and that the variables for understanding them have some universality.

An article written by members of CSA SSG team examining megacities noted that while there are certainly similar types of systems in megacities,

What emerged from our analysis is a typology ranging from cities that are highly integrated (e.g. New York City or Tokyo) with hierarchical governance and security systems, to cities that are loosely integrated (e.g. Lagos, Nigeria or Dhaka, Bangladesh) with alternatively governed spaces and security systems. Some cities exhibit a combination of the two.²⁴

²¹ ADRP 3-0, p. B-2.

²² JP 3-06, pp. II-3-II-4.

²³ JP 3-06, pp. II-4-II-14.

²⁴ Bailey et al., 2014.

The article maintains that each megacity is unique and needs to be understood individually. Indeed, there may be little similarity between megacities, other than the qualification that they must have at least 10 million occupants. The question then becomes how to deal with a particular megacity.

Take, for example, Karachi in Pakistan. It has a population of close to 24 million people, just slightly less than the entire country of Iraq. To try to grasp this urban density, let's assume everyone who works at the Pentagon took their immediate family to work with them one day; you would need more than 300 of these Pentagons to get close to mimicking just how many people live in Karachi. Living conditions in Karachi are unfathomable to most Americans, who are accustomed to space and sprawl. Yet Karachi is no slum and served for over a decade as Pakistan's capital. Karachi is a port town, the Hong Kong or Tangier of South Asia – a place perpetually in motion, where who or what is "local" can be hard to define, given the import and export of both goods and people. The mix of ethnicity also reflects the blend of languages spoken in Karachi, as well as the numerous political parties reigning over this megacity.

By comparison, consider Ramadi, Iraq, which could be thought of as one of the last frontier towns of Al Anbar Province. Terrain west of Ramadi is a straight, desert-laden dash to the border of Jordan or Syria. But to think of Ramadi as a remote Wild West overlooks it as both an urban population center and an Iraqi capital of provincial government. While census estimates have been hard to obtain in the past decade, Ramadi is thought to contain about 500,000 residents, mainly all from the same tribe. Demographically, Ramadi serves as a cornerstone of the Sunni Triangle, and topographically, the Euphrates River and its offshoot, the Ramadi Dam, triangulate the city. This geography pushes the populace close to the government center, close to work, and close to each other, without having to cross one of the few crucial bridge spans connecting the region.

Against an enemy force that knows how to use urban terrain and is willing to fight to achieve an objective, such cities present an extremely challenging environment for military forces to conduct operations. What is needed are forces that can integrate intelligence and

operations and are capable of conducting combined arms operations to fight for information. Doing so develops situational understanding in close contact with the enemy and civilian population.

Which Cities Matter, and How Do You Know?

Urbanization is on the rise, but the question for the Army is which cities matter. Table 1.1 lists megacities (cities with populations over 10 million) as of 2015.

What is important about this table is the fact that the vast majority of the listed megacities will not be combat challenges for the Army. Several may provide humanitarian demands (e.g., Dhaka) or requirements for large-scale noncombatant evacuation operations, but few are locations where the Army might have to fight. Furthermore, there are cities that are not megacities that are in countries where there are active U.S. combat operations, e.g., Mosul in Iraq.

The Army's shift to regionally aligned, globally engaged forces supporting the geographic combatant commanders through the Regionally Aligned Forces concept offers an approach whereby Army commanders can begin to understand which cities are important in their region as well as the nature of the problems they may present. This is a central point: The city is not the problem, but the context within which a problem resides. This understanding will enable operational planners and the intelligence community to focus on providing "Phase Zero," or pre-battle, assessments and comprehensive planning that is specific, rather than generic. Understanding the specific city itself is only relevant so far as is needed to address the problem that resides in that city.

Table 1.1
Megacities as of 2015

Urban Area	Population Estimate	Land Area (square miles)	Density (population per square mile)	Land Area (km ²)	Density (population per km ²)
Tokyo-Yokohama, Japan	37,843,000	3,300	11,500	8,547	4,400
Jakarta, Indonesia	30,539,000	1,245	24,500	3,225	9,500
Delhi, India	24,998,000	800	31,200	2,072	12,100
Manila, Philippines	24,123,000	610	39,500	1,580	15,300
Seoul-Incheon, South Korea	23,480,000	875	26,800	2,266	10,400
Shanghai, China	23,416,000	1,475	15,900	3,820	6,100
Karachi, Pakistan	22,123,000	365	60,600	945	23,400
Beijing, China	21,009,000	1,475	14,200	3,820	5,500
New York, United States	20,630,000	4,495	4,500	11,642	1,800
Guangzhou-Foshan, China	20,597,000	1,325	15,500	3,432	6,000
Sao Paulo, Brazil	20,365,000	1,045	19,500	2,707	7,500
Mexico City, Mexico	20,063,000	800	25,100	2,072	9,700
Mumbai, India	17,712,000	211	83,900	546	32,400
Osaka-Kobe-Kyoto, Japan	17,444,000	1,240	14,100	3,212	5,400
Moscow, Russia	16,170,000	1,800	9,000	4,662	3,500
Dhaka, Bangladesh	15,669,000	139	112,700	360	43,500
Cairo, Egypt	15,600,000	680	22,900	1,761	8,900
Los Angeles, United States	15,058,000	2,432	6,000	6,299	2,400
Bangkok, Thailand	14,998,000	1,000	15,000	2,590	5,800
Kolkata, India	14,667,000	465	31,500	1,204	12,200

Table 1.1—continued

Urban Area	Population Estimate	Land Area (square miles)	Density (population per square mile)	Land Area (km²)	Density (population per km²)
Buenos Aires, Argentina	14,122,000	1,035	13,600	2,681	5,300
Tehran, Iran	13,532,000	575	23,500	1,489	9,100
Istanbul, Turkey	13,287,000	525	25,300	1,360	9,800
Lagos, Nigeria	13,123,000	350	37,500	907	14,500
Shenzhen, China	12,084,000	675	17,900	1,748	6,900
Rio de Janeiro, Brazil	11,727,000	780	15,000	2,020	5,800
Kinshasa, Democratic Republic of Congo	11,587,000	225	51,500	583	19,900

SOURCE: “WORLD MEGACITIES: Urban Areas with More Than 10,000,000 Population,” from *Demographia World Urban Areas*, 2015.

Shrinking the Problem or Not: Lessons from Four Urban Combat Operations

The previous chapter provided a framework for thinking about urban combat, sketching out the challenges cities present and also indicating some of the opportunities they contain. This chapter discusses four examples of such combat: the Russian Army in Grozny in 1994 and in 1999, the U.S. Army in Mogadishu in 1993, the U.S. Army in Baghdad in 2003, and the U.S. Army in Sadr City Baghdad in 2008.

If urban warfare is a possibility for the U.S. Army in the future, a deeper understanding of past urban challenges and opportunities will go a long way in developing concepts of operations that mitigate the former and exploit the latter. When conceiving of military operations in urban environments, the trick is to reduce the scope of the operational problem to make it manageable. “Shrinking the problem” is a metaphor for developing a conceptually appropriate way to reduce the magnitude of an urban environment to the point where military forces can exploit localized nuances to operational effect. These nuances include, for example, the local drivers of conflict, the tactical firing positions of urban dwellings, the will of the civilian population, and the neighborhood itself, each of which can become a military force’s greatest ally or worst foe.

The following four historical cases show in practice the meaning of shrinking the operational problem – or not – for a military force operating in urban environments. These four historical cases shed light on whether or not military forces operating in challenging urban environments were able to shrink the magnitude of a city, large or small,

down to a neighborhood-sized problem through creative thinking that produced effective operations.

One capability that stands out in each of the four cases for a military force conducting operations in an urban environment is the usefulness of mobile protected firepower. Although not a guarantor of success in urban environments by any measure, armored forces offer a much greater probability of success than do ground forces that operate without them.

U.S. and Other UN Military Forces in Mogadishu, 1993

The United Nations began a large-scale humanitarian relief operation in 1992 to alleviate mass starvation and human suffering occurring in Somalia after numerous warring clans ousted strong-arm President Siad Barre. As a result of the power vacuum, competing clans began fighting for control of highly coveted UN food supplies and distribution, resulting in 20,000 civilians killed and millions more caught in the middle of the crossfires.¹

The United States offered to assist UN efforts to ensure the delivery of humanitarian assistance. President George H. W. Bush anticipated little resistance and planned for limited objectives:

Our mission has a limited objective, to open the supply routes, to get the food moving, and to prepare the way for a U.N. peacekeeping force to keep it moving. This operation is not open-ended. We will not stay one day longer than is absolutely necessary.²

¹ Richard W. Stewart, *United States Forces, Somalia After Action Report and Historical Overview, The United States Army in Somalia, 1992–1994*, Washington, D.C.: U.S. Army, Center of Military History, 2003, pp. 3–41; see also Associated Press, “Somalia’s Rivals Agree on a Truce,” *Los Angeles Times*, February 15, 1992.

² “Mission to Somalia; Transcript of President’s Address on Somalia,” *New York Times*, December 5, 1992.

With this mindset, the United States went into Somalia with a minimal amount of military power initially intended to assist in the distribution of food supplies – not for combat operations.

Through the spring and summer of 1993, the U.S. deployed a task force to Mogadishu made up of elements of a brigade combat team (BCT) from the 10th Mountain Division and attached civil affairs and support units. The U.S. task force worked in support of a Pakistani brigade in Mogadishu tasked to maintain pressure against the clansmen who were trying to disrupt supply lines.³ The task force also acted as an emergency response force that could move quickly and apply air delivered firepower with its Cobra attack helicopters.⁴ Importantly, however, the U.S. task force had no tanks or mechanized infantry: “There were only eight tanks in Mogadishu. . . . They were old American tanks that had been given to the Pakistanis, and of those only four were operational.”⁵ The Malaysians also had wheeled armored personnel carriers, both of which proved invaluable in later fighting against the clansmen.

As U.S. and UN forces continued their effort to assist in humanitarian relief, they came in increasing contact with the warring clans, which had lucrative interests in controlling the distribution of relief.⁶ Clansmen fought using small arms, rocket-propelled grenades (RPGs), at times light mortars, and from pickup trucks with mounted heavy-caliber machine guns. Although these clansmen did not have sophisticated organizational structures or C2, they fought tenaciously and used the urban terrain in Mogadishu, which they knew well, to their advantage.

By late spring 1993, the UN and the United States decided to step up their military activity in a combat role against the clans, to bring security and control to the country so that humanitarian relief could

³ Stewart, 2003, p. 30.

⁴ Stewart, 2003, pp. 6–7.

⁵ Public Broadcasting Service, “Ambush in Mogadishu: Interview with General Thomas Montgomery (Ret.),” *Frontline*, PBS.

⁶ Clayton Chun, *Gothic Serpent: Black Hawk Down Mogadishu 1993*, Oxford, UK: Osprey Publishing, 2012, p. 23; Stewart, 2003, p. 5.

proceed.⁷ However, the military forces at the disposal of the UN did not have the strength or, more important, the political will of the varying countries involved to see it through. UN military commanders on the ground made consistent requests to UN Headquarters to solicit other contributing nations to provide more armored forces. The rationale for the need for armored forces was quite simple: Armored forces allowed freedom of movement in Mogadishu because the armor created an overmatch in protection, mobility, and lethality that the lightly armed clansmen could not match.⁸

Senior U.S. military commanders in Somalia agreed. As attacks against UN and U.S. forces increased in the month of July, U.S. political leadership decided to add U.S. special operation forces, combined with an Army Ranger company, to apply more targeted military power against key clan leadership. Major General Thomas Montgomery, the senior U.S. commander, requested a contingent of mechanized infantry and an armored task force. This would enable freedom of movement through the streets of Mogadishu and quick reaction force capabilities when needed. But U.S. political leadership, still focused on playing a limited and short-duration role in Somalia, denied the request for armored forces.⁹

Despite the lack of heavy armored support or any mobile protected firepower, on October 3, Special Operations Task Force (TF) Ranger conducted a raid that inserted heliborne U.S. special operations forces into one of the most heavily clan-defended areas of Mogadishu. From a narrow special operations perspective, the operational plan was well thought out, with a detailed sequencing of actions, from the sealing of the compound where the clan leaders were located, to the heliborne insertion of the special operations forces, and to the extraction of the prisoners by a mounted column of light-skinned Humvees manned

⁷ Stewart, 2003, p. 8.

⁸ Valerie J. Lofland, *Somalia: U.S. Intervention and Operation Restore Hope*, Maxwell Air Force Base, Ala.: The Air University, 2002, p. 58; Stewart, 2003, pp. 6–7, 63–64.

⁹ Public Broadcasting Service, 2014.

by the Rangers.¹⁰ However, what was not imagined by the special operations leadership was the need to have an extraction force made up not of light-skinned Humvees but tanks and armored personnel carriers. These forces had proved their worth in the preceding months to the Pakistani leadership and senior U.S. leadership. U.S. planners for the raid could have requested a responsive Pakistani reaction force linked into the operational plan and placed on short notice alert. Alas, such creative thinking was not to be, and TF Ranger soon discovered that instead of shrinking the problem at hand down to a neighborhood, they instead had seemingly the entire city to confront.

Although the special operations forces quickly captured a number of high-level clan leaders, the extraction of those captives along with the special operations forces proved to be a debacle. The plan for extraction centered on a column of light-skinned Humvees manned by Army Rangers to move through the city to the capture point and remove them quickly back to the Ranger compound. But the capture point was located in the main stronghold district for militia fighters. Almost from the start, the unarmored Humvees took withering small arms, machine gun, and RPG fire. The Somali clansmen, aided by civilians, conducted swarm attacks and created roadblocks that prevented the vehicles from reaching the capture site.¹¹ The eventual shooting down of two U.S. Blackhawk helicopters complicated the situation further. The officer in charge of the mounted Ranger convoy of light-skinned Humvees, Lieutenant Colonel Danny McKnight, had taken so many casualties that he was unable to move to the crash site of one of the downed helicopters to assist them, alerting the command helicopter circling above him that he had taken “quite a few casualties. Getting to

¹⁰ Michael Gordon, “Details of U.S. Raid in Somalia: Success So Near, a Loss So Deep,” *New York Times*, October 25, 1993; Stewart, 2003, p. 8; and Lawrence Lyons and Ahmed I. Samatar, *State Collapse, Multilateral Intervention, and Strategies for Political Reconstruction*, Washington, D.C.: Brookings Institution Press, 1995, p. 59.

¹¹ David E. Johnson, Adam R. Grissom, and Olga Olikier, *In the Middle of the Fight: An Assessment of Medium-Armored Forces in Past Military Operations*, Santa Monica, Calif.: RAND Corporation, MG-709-A, 2008, p. 134.

the crash site will be awful tough. Are pinned down.”¹²The city map in Figure 3.1 depicts the situation in Mogadishu. It shows the two helicopter crash sites in relation to the target objective and the disposition

Figure 3.1
Mogadishu Street Battle

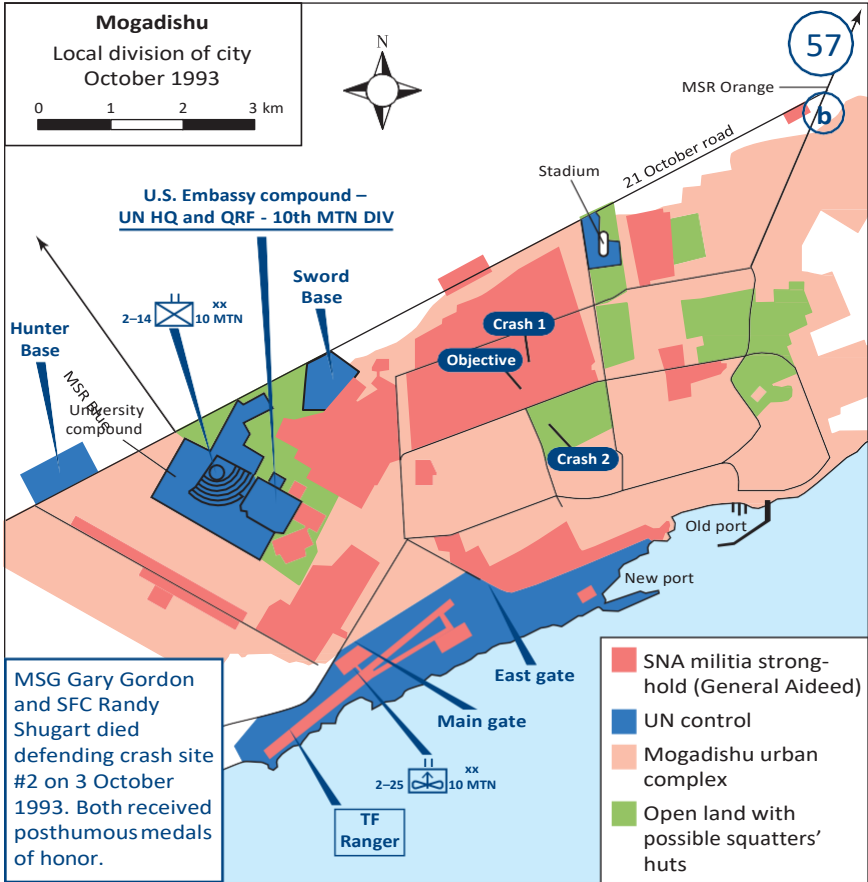

NOTE: SNA = Somali National Alliance.

SOURCE: U.S. Military Academy.

RAND RR1602-3.1

¹² Mark Bowden, *Black Hawk Down: A Story of Modern War*, Berkeley, Calif.: Atlantic Monthly Press, 1999, p. 130.

of enemy forces that cannibalized the streets in advance of the U.S. and UN forces sent to rescue the trapped soldiers.

After an intense 24-hour period of close combat, the Ranger mounted and dismounted elements and, finally, supported by Pakistani armor and mechanized forces and a smaller contingent of Malaysian mechanized infantry vehicles, extracted themselves from heavy contact with Somali clansmen. By that point, 18 Army Rangers had been killed and over 50 wounded in what turned out to be at that time the most intense firefight involving U.S. combat forces since the Vietnam War.¹³ Although the Rangers were a superbly trained and equipped light infantry fighting force and inflicted heavy casualties on the Somali clansmen, the lack of armored vehicles made it difficult to generate the kind of movement capability required to protect and extract personnel from a “city that was shredding them block by block.”¹⁴

The case of the U.S. Army in Mogadishu shows that while ground combat forces play a big role in reducing the operational problem in an urban area down to a manageable level, so too do the strategic and policy level decisions that put ground tactical forces into action. Some of the decisions made in 1993 by the U.S. and UN contributing nations’ political leadership actually made the operational problem for tactical forces unshrinkable. The political decision not to increase the amount of armored forces for UN contributing states and the U.S. decision not to send tanks and mechanized fighting vehicles once ground elements began sustained combat operations doomed those tactical forces to dealing with a level of magnitude that they simply could not handle. This is not to say that tactical needs must always trump political goals, but rather that the two must integrate, and decisionmakers must understand the operational and political objectives involved and how policy decisions can impose limitations on achieving operational objectives. It is also the case that having U.S. armored forces in Soma-

¹³ Kilcullen, 2013, p. 74. For additional details of the battle, see Bowden, 1999. See also Kenneth Allard, *Somalia Operations: Lessons Learned*, Washington, D.C.: National Defense University Press, 1995.

¹⁴ Bowden, 1999, p. 158.

lia would have made the attainment of political goals there more likely. Still, even with the political decision not to deploy U.S. armored forces to Somalia, special operations and Ranger commanders on the ground could have requested Pakistani armor and then had closely integrated into the tactical plan. Therefore, imaginative thinking at the tactical level is always an imperative in tough urban combat operations.

Russians in Grozny, 1994–1996, 1999–2000

Grozny I

In December 1994, a little more than a year after TF Ranger's harrowing fight in Mogadishu, the Russian Army advanced on the city of Grozny as part of a larger campaign to subdue the population and wrest control of Chechnya from separatists fighting for independence. The battle for Grozny took over a year and a half to fight and ended in a demoralizing ceasefire that favored the separatists. Grozny's resistance fighters mounted a robust defense, and having the home field advantage enabled them to exploit their knowledge of the terrain and its population. While the separatists deserve much of the credit, a closer look at the state of the Russian Army suggests that, in many ways, the Russians defeated themselves by oversimplifying the problem and underestimating their enemy's will and capacity to fight the urban battle. This mindset resulted in an ill-prepared Russian Army that enlarged the operational problem rather than shrinking it.

The Russians glossed over many of the challenges of fighting the urban battle and assumed (to their regret) that the city of Grozny would largely fall uncontested. The initial strategy called for a 6,000-troop-strength force deployed in tanks and dismounted infantry to conduct a show-of-force campaign to encircle the city and capture key government buildings and other significant infrastructure.

What the Russians failed to appreciate was just how much the urban environment favors the defender. Figure 3.2 depicts many of the features of the urban landscape that enemy forces and sympathetic locals who are familiar with the terrain can exploit, from attack positions above and inside multistory buildings to maneuver routes in sub-

Figure 3.2
Urban Battlespace

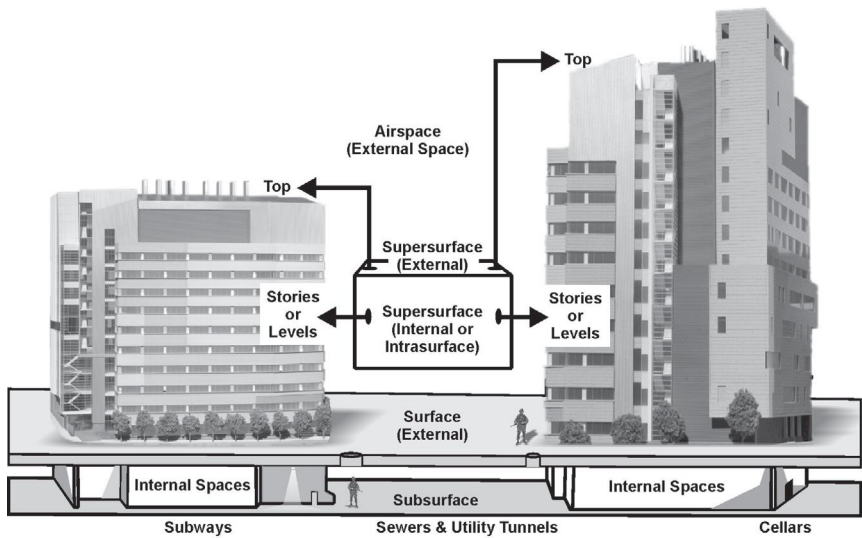

SOURCE: ATP 3-06.11; FM 3-06.11.

RAND RR1602-3.2

terranean underground sewer systems below. These were locations that Russian vehicles could not engage because their tank guns could not elevate or depress sufficiently.

Additionally, as with the combat vehicles of most armies, Russian vehicles were designed for head-to-head combat with other armored vehicles, and what seemed to be reasonable design trade-offs about protection from top, side, and rear attacks were made to accommodate conventional challenges. Chechen fighters took advantage of these vulnerabilities in 1995. During the operations in Grozny in 1995, poorly trained Russian soldiers had attempted to force a *coup de main* on the city, relying heavily on armored vehicles, including tanks. Yet, conventional mechanized forces were no match for Chechen small guerrilla units that could fire off a few rounds and quickly drive off to avoid counterfire. The city's narrow, winding streets enabled snipers to target and immobilize the front and rear vehicles of Russian tank columns, rendering the middle vehicles easy prey for RPGs. Additionally, the

main guns of the tanks could not elevate or decline enough to engage and counterattack these rebel positions.¹⁵ As a result, the Russian Army struggled and ultimately failed to control the outer layers of Grozny on the way to the city center, enabling resistance fighters to maneuver and resupply as needed.

The Russians did not conduct a rigorous IPB, which would have highlighted such critical nuances about the urban terrain. It also would have revealed the proliferation of RPGs and anti-aircraft weapons and talented snipers, and the enemy's proclivity and acumen for ambush warfare. Additionally, the lack of an adequate IPB produced infantry soldiers unfamiliar with the language and indifferent to local culture. Soldiers stole food and ignored religious sensitivities, which insulted locals and turned a passive population into active supporters and fighters for the resistance.¹⁶

Training was a particular weakness. The Russian Army had not held a divisional or regimental field exercise since 1992. What training had occurred was primarily focused on preparing soldiers for "when the Cold War turned hot," across the open terrain of Eastern Europe rather than the urban environment. Less than 5 percent of training focused on fighting in an urban terrain. "For many, the sole preparation for the urban mission was an institutional pamphlet on urban combat . . . printed in such small numbers that troops had to share."¹⁷

Additionally, commanders cobbled together ad hoc units that lacked discipline and cohesion. For example, the fighting forces consisted of inexperienced conscripts who refused to dismount to prevent resistance fighters from targeting their armored vehicles' weak spots (fuel cells, engines, the top, rear, and sides, rather than the fortified front armor). Additionally, soldiers were drawn from myriad entities (Ministry of Defense, Ministry of Internal Affairs, Federal Security

¹⁵ Olga Oliker, *Russia's Chechen Wars 1994–2000: Lessons from Urban Combat*, Santa Monica, Calif.: RAND Corporation, MR-1289-A, 2001, pp. 10–14; Lester Grau, "Russian Urban Tactics: Lessons from the Battle for Grozny," *Strategic Forum*, No. 38, July 1995, p. 3.

¹⁶ Lester W. Grau and Timothy L. Thomas, "Russian Lessons Learned From the Battles for Grozny," *Marine Corps Gazette*, April 2000; Grau, 1995, p. 2.

¹⁷ Oliker, 2001, p. 8–9.

Service, and local Russian loyalists), which confused C2 authorities and created interoperability problems. Units that had not trained together were unfamiliar with each other's communication procedures, which led to unsecure communication channels that enabled separatists to overhear tactical planning and insert disinformation that had Russian assets targeting their own forces. In one telling example, a Russian tank unit engaged with a Russian motorized rifle unit during a six-hour battle before they identified each other as friendlies. Estimate suggests that 60 percent of Russian casualties were self-inflicted.¹⁸

The Russians showed little regard for the unique challenges the urban environment presented for air assets. Prior to the December advance, Russian Defense Minister General Pavel Grachev boasted that he could easily take Grozny in a couple of hours with one airborne regiment. But aircraft were vulnerable to anti-aircraft weapons (SA-7s and SA-14s), and poor weather conditions exacerbated the problem. Even when cleared, air assets found it difficult to penetrate targets with surveillance systems that were better suited for intelligence gathering over open terrain.¹⁹

The Russians eventually made a comeback, but only after a change in command and the new leadership's willingness to shift tactics. By mid-January 1995, Russia surged its troop strength in Chechnya to 30,000, with many concentrated near Grozny. The reinforcements included specialized assault detachments with experience in hand-to-hand combat. Equipment improved and included secure communications capabilities, all of which increased the mobility and lethality of the offensive. It also enabled the Russians to capture and hold key infrastructure and to destroy the presidential palace.

Russian forces were never able to fully seal off the city, however, which enabled the separatists to simply blend back into the popula-

¹⁸ Olikier, 2001, p. 20; Johnson, Grissom, and Olikier, pp. 16, 120; Grau and Thomas, 2000; Grau, 1995, p. 1. Gregory J. Celestan, *Wounded Bear: The Ongoing Russian Military Operation in Chechnya*, Fort Leavenworth, Kan.: Foreign Military Studies Office Publications, August 1996.

¹⁹ Mark Galeotti, *Russia's Wars in Chechnya, 1994–2009*, Oxford, UK: Osprey Publishing, 2014, p. 32; Celestan, 1996; Michael Coffey, "Military Learning Between the Chechen Wars," *Journal of Russian and Asian Studies*, October 24, 2006.

tion, ready to fight another day. They did so on multiple occasions over the course of the next year. Russians suffered hundreds of casualties in towns they thought they had already captured, only to find that the resistance had shifted tactics, engaging in high-profile kidnappings and terrorist attacks. By August 1996, a demoralized Russian force negotiated a ceasefire settlement and relinquished de facto control to the resistance.

During the first battle for Grozny, the Chechen separatists had no choice other than to shrink the problem down to the neighborhood. However, they managed to turn that problem into a defensible solution against an enemy that had largely discounted much of the complexities of fighting the gritty urban fight. But the Russians demonstrated an impressive ability to learn from their mistakes over the next few years.²⁰

Grozny II

In the second battle for Grozny (1999–2000), the Russian attackers faced well-prepared, committed defenders who had gone to similar lengths as the first battle to prepare for a Russian return. Analyst Timothy L. Thomas described the extensive preparations made by the Chechen rebels as the Russians approached the city in 1999:

The Chechen force had two months to prepare the city and they constructed a number of ambush points. The rebels had two defense lines, with the least-skilled personnel in the front. Snipers occupied roofs and upper floors of buildings, controlling distant approaches to specific intersections. They attempted to draw the Russians out into the street. . . . Snipers also could be found in trenches and under concrete slabs that covered basements. These slabs could be raised with car jacks when Russian forces approached, provide ambush firing positions, and then drop back down. The attacking Russian force struggled to discern what was merely rubble and what was a kill zone. . . .

²⁰ For an excellent historical overview of urban combat and the need for armored, mechanized forces, see Louis A. DiMarco, *Concrete Hell: Urban Warfare from Stalingrad to Iraq*, London: Osprey Publishing, 2012.

The Chechens used the trenches to move between houses and as sniper positions. As the Russian force focused on the tops of buildings or on windows, they were often attacked from the trenches, a sort of attack by misdirection. The Chechens stated that in the city they did not use body armor because it slowed them down, or tracers, which revealed their positions too precisely. . . .

Finally, the impressive mobility of the Chechen force included escape routes from firing positions, interconnected firing positions and again the sewer network to move about the city. Reportedly a computer in Grozny kept track of everyone in the city and other areas of Chechnya who reported in by radio. Russian forces especially feared the nighttime, when the Chechens would move against and reclaim abandoned positions. The Chechen force allegedly used chlorine and ammonia bombs, set oil wells on fire to obscure fields of vision and rigged entire building complexes with explosives. . . .

The Chechens boarded up all first-story windows and doors, making it impossible to simply walk into a building. While trying to climb ladders or knock in doorways, Russian soldiers became targets for Chechen snipers positioned on upper floors. Reportedly the Chechens were divided into 25-man groups that were subdivided into three smaller groups of eight each that tried to stay close to the Russian force (again, “hugging” the Russian force as during the 1995 battle to minimize the Russian artillery effort).²¹

As one Russian commander noted about the quality of his adversary during the 1999 battle for Grozny, “a Chechen company can match head for head a Russian brigade.”²² That said, the Russians had learned from the debacle of their operations in Grozny in 1995 and approached the challenge much differently the second time around. Russian forces improved their strategic odds of victory by focusing on tactical competency. For example, unlike the first war, the Russians were now carry-

²¹ Thomas, 2000.

²² Thomas, 2000.

ing out predeployment reconnaissance at the granular level, leveraging language interpreters and intelligence gleaned from Chechen loyalists. This tactic played a role in the Russian military's ability to advance largely uncontested through the outer villages surrounding Grozny.²³

Within Grozny, military planners divided the city into 15 sectors to identify enemy strongpoints, underground corridors, and arsenals. In doing so, planners gained a better understanding of the vertical dimensions of urban fighting in Grozny, with its high-rise buildings and basement bunkers. Instead of trying to storm the city, they essentially besieged it with 50,000 troops and employed a deliberate approach to systematically destroy the some 4,000 rebels still in the city.²⁴ Grozny was also subjected to an unrelenting air campaign. The objective of the air campaign was "demoralizing the will of the populations to resist and the complete ruination of the internal infrastructure of Chechnya. . . . Targets included dams, weirs, water distributions systems, fuel dumps, oil installations, the telephone system, and the electricity supply system."²⁵ Essentially, Grozny was a "freefire zone."²⁶

Instead of trying to storm the city with poorly trained troops, the Russians relied principally on fires directed by reconnaissance units, either mounted in the PRP-4 artillery reconnaissance variant of the BMP infantry fighting vehicle or dismounted teams, to destroy rebel positions and fighters. Ground force "storm teams" followed up after rebels had been suppressed. Tanks, unlike in 1995, largely stayed out of the city, instead providing stand-off direct fires out of the range of the threat of Chechen rebel RPGs and other weapons.²⁷ When tanks were brought into the city, they

were there to follow and support the storm detachments rather than to lead. Armored vehicles moved through the city sur-

²³ Grau and Thomas, 2000; Oliker, 2001, pp. 14, 52; Coffey, 2006.

²⁴ Thomas, 2000.

²⁵ Richard D. Wallwork, *Artillery in Urban Operations: Reflections on Experiences in Chechnya*, thesis, U.S. Army Command and General Staff College, 2004, p. 51.

²⁶ Thomas, 2000.

²⁷ Thomas, 2000.

rounded by the dismounted infantry of the attack group. The vehicles could thus effectively engage enemy snipers and automatic riflemen in the buildings that the attack troops could not reach, while being protected by the infantry who would keep the enemy from coming close enough to the armor to destroy it.²⁸

From 1999 through 2000, the Russians lost just one tank and had lower friendly fire casualties, suggesting that they figured out how to better coordinate ground operations between tanks and infantry and between ground forces and preceding artillery and airpower.²⁹ Equally important in Grozny II was the decision of the Russian high command to use its mobile protected firepower assets to essentially surround the city using firepower to reduce the enemy force inside while conducting only limited armored raids into the city. The Russians used the full range of their conventional capabilities, including combat aviation, mortars (including the 2S2 250mm Tyulpan self-propelled mortar), artillery (122mm and 152mm), rockets (Smerch 300mm, Uragan 220mm, and TOS-1 220mm), and SCUD, SS-1, and SS-21 missiles.³⁰ Artillery accounted for some 70 percent of fire missions; aviation 30 percent.

Russian artillery systems that showed particular utility were the 2S4 and the TOS-1.³¹ The 2S4 was useful because of its heavy warhead and precision-guided 276 pound *Smel'chak* (Daredevil) round. It also has special munitions, e.g., concrete-piercing. The Russians had learned in Afghanistan that medium artillery (122mm and 152mm) were often not effective against mujahideen strongholds. They faced similar challenges in Chechnya in the mountains and in Grozny, because "152 millimeter ammunition does not have the ability to achieve many of the missions of heavier ammunition because of its low explosive content

²⁸ Oliker, 2001, p. 45.

²⁹ Oliker, 2001, p. 47

³⁰ Wallwork, 2004, pp. 52, 68.

³¹ Wallwork, 2004, pp. 65–70.

and low mass, regardless of the numbers used.”³² Quite simply, strong targets required large projectiles to defeat and frequently as well high-angle fire because of the location of target in mountains or cities.³³

The TOS-1 *Buratino* is a 30-barrel 200mm multiple rocket launcher mounted on a T-72 tank chassis observed fire system with a range, depending on model, of between 3.5 and 5 kilometers and a minimum range of 400 meters. The rockets have thermobaric warheads, and “[t]he zone of destruction from a Buratino salvo is 200 x 400 meters.”³⁴ The weapon’s characteristics made it particularly effective in Grozny:

The thermobaric warhead is filled with a combustible liquid. The liquid is most likely filled with powdered tetranite. When the warhead explodes, the liquid is vaporized creating an aerosol cloud. When the cloud mixes with oxygen, it detonates, first creating a high temperature cloud of flame followed by a crushing overpressure.³⁵

The Russians also used thermobaric weapons in the close fight in the form of the RPO-A *Schmel* (Bumblebee).

Another veteran of Afghanistan, the RPO-A flamethrower is a shoulder-fired, single-shot, disposable weapon with a maximum range of 1,000 meters, a maximum effective range of 600 meters and a minimum range of 20 meters. . . . The RPO-A is best used as a bunker buster. Its two-kilogram warhead readily knocks out bunkers and strongpoints.³⁶

³² Quoted in Wallwork, 2004, pp. 65–67; the citation given in Wallwork is A. F. Bulatov, S. V. Lomanchenko, and S. L. Gavrilovich, “Heavy Artillery: Notes on the Evolution,” *Voennaia Mysl* (Military Thought).

³³ Lester W. Grau, “The High-Precision Tulip: Development and Combat Employment of the Soviet Laser-Guided Mortar Round,” no date; Wallwork, 2004, pp. 65–67.

³⁴ Lester W. Grau and Timothy Smith, “A ‘Crushing’ Victory: Fuel-Air Explosives and Grozny 2000,” *Marine Corps Gazette*, August 2000.

³⁵ Grau and Smith, 2000.

³⁶ Grau and Smith, 2000.

The implications of thermobaric weapons are significant, as analysts Lester Grau and Timothy Smith note:

a thermobaric strike on a unit in an urban fight is likely to be very bloody. Those personnel caught directly under the aerosol cloud will die from the flame or overpressure. For those on the periphery of the strike, the injuries can be severe. Burns, broken bones, contusions from flying debris and blindness may result. Further, the crushing injuries from the overpressure can create air embolism within blood vessels, concussions, multiple internal hemorrhages in the liver and spleen, collapsed lungs, rupture of the eardrums and displacement of the eyes from their sockets. Displacement and tearing of internal organs can lead to peritonitis [*sic*]. Most military medics are well trained in stopping the bleeding, protecting the wound and treating for shock. Many of the injuries caused by thermobaric weapons are internal and may not be initially noticed by the medic or doctor.³⁷

The TOS-1 and missile strikes, aside from physical damage, also had a psychological effect on the Chechen rebels:

In a surprising and threatening move, the federal forces relied heavily on fuel-air explosives and tactical missiles (SCUD and SCARAB). These systems suppressed the Chechens both physically and psychologically and these assets were used to attack fighters hiding in basements. Such fire strikes were designed for maximum psychological pressure—to demonstrate the hopelessness of further resistance against a foe that could strike with impunity and that was invulnerable to countermeasures. The

³⁷ Grau and Smith, 2000. As described by Lester W. Grau, "Underground Combat: Stereophonic Blasting, Tunnel Rats and the Soviet-Afghan War," *Engineer*, November 1998, the Soviets employed thermobaric weapons for subterranean operations in Afghanistan, and the mujahideen used

the extensive underground *karez* (manmade water system). . . . Some of these *karez* stretch for several kilometers underground. . . . they are ready-made shelters from bombing and artillery attacks. The guerrillas would dig caves in the sides of the shafts to hide weapons and themselves and use the *karez* tunnel network to move undetected to and from ambush sites and attack positions.

TOS-1, heavy flame system, (a multiple rocket launcher mounted on a T-72 tank chassis) played a particularly prominent role as a terror weapon.³⁸

The Russians also employed information operations much more effectively in 1999. They controlled the message, as noted by Russian reporter Andrey Soldatov:

Whereas during the first Chechen campaign the majority of television reports and newspaper articles were couched in terms of sympathy with the rebel republic, this time the situation is the absolute opposite. Ruthless censorship is not letting Wahhabist propaganda get through . . . battle reports from Basayev, Khattab, and their minions, interviews with guerrillas – items given high-profile coverage on all channels during the last war – are now banned.³⁹

The Russians were therefore able to maintain public support for the war in Chechnya.

Information operations (IO), albeit of a different nature, were employed by Coalition forces in Fallujah. The Coalition IO campaign focused on

“creating additional ‘maneuver’ room for combat operations in Fallujah” . . . by countering the enemy IO, and conducting IO shaping operations to “build a strong base of support for combat operations in advance of the operation.” . . . [This included] a robust media embed program.⁴⁰

³⁸ Thomas, 2000.

³⁹ Timothy L. Thomas, “Information Warfare in the Second (1999–) Chechen War: Motivator for Military Reform?” in Anne C. Aldis Roger N. McDermott, eds., *Russian Military Reform 1992– 2002*, London: Frank Cass, 2003.

⁴⁰ William Knarr, Robert Castro, and Dianne Fuller, *The Battle for Fallujah Al Fajr – the Myth-Buster*, IDA Paper P-4455, Arlington, Va.: Institute for Defense Analysis, 2009, p. 52, quoting LTG Thomas Metz and LTC James Hutton, “Massing Effects in the Information Domain: A Case Study in Aggressive Information Operations,” *Military Review*, May–June 2006, p. 6.

The Russians also used psychological operations to convince civilians to leave Grozny and to encourage Chechen rebel fighters to surrender. They also used “reflexive control operations” to deceive the rebels. A famous case is recounted by analyst Timothy Thomas:

Another reflexive control operation was the Russian attempt to convince Chechen defenders that they might safely withdraw southwesterly from the city under the cover of darkness. The Russians achieved their goal using fake radio nets purposely left open to the Chechen force and over which they communicated this vulnerability openly. In reality, the Russians were waiting for and crippled the withdrawing Chechens with mines and blocking forces.⁴¹

In the 1999 battle, the Russians employed Chechen fighters aligned with them under former Grozny Mayor Bislan Gantamirov as fighters and as a valuable source of human intelligence, a

practice which overcame many problems associated with tactics and language in the city. Chechen combatants friendly to the federal cause and led by Gantamirov could talk with the local population and get intelligence on the rebel positions and dispositions. Chechen human intelligence often proved more valuable than Russian signal intelligence.⁴²

The Russians themselves were also far better prepared in 1999 than they had been in 1995. Lieutenant General Gennadiy N. Troshev, first deputy commander of the Combined Troop (forces) Grouping, noted:

planners “painstakingly studied not only the streets and the routes of approach to some regions of the city, but also to all its public utilities. We raised all of the archives, found maps . . . based on them we determined where the sewage lines are and how and where the heating lines go . . . there are labyrinths as tall as a

⁴¹ Thomas, 2000.

⁴² Thomas, 2000.

man and 2 to 3 meters wide. Therefore, before we began to storm the city, combat engineers and reconnaissance personnel went out to these public utilities.”⁴³

Finally, the Russians learned from 1995 that

The psychological impact of high intensity urban combat is so intense that you should maintain a large reserve that will allow you to rotate units in and out of combat. If you do this, you can preserve a unit for a fairly long time. If you don’t, once it gets used up, it can’t be rebuilt. . . . Training and discipline are paramount. You can accomplish nothing without them. You may need to do the training in the combat zone. Discipline must be demanded. Once it begins to slip, the results are disastrous.⁴⁴

Thus, with better tactics and imaginative planning along with coordination of arms, the Russian Army was able to maintain a freedom of movement that it could not muster during the 1994–1995 war. While sporadic firefights broke out occasionally, the resistance eventually diminished in manpower and supplies and was never able to mount the same level of fight it once had. The fight for Grozny officially came to a close with a Russian victory.

3ID Armored Raids on Baghdad, April 5 and 7, 2003

U.S. forces made maximum use of combined arms operations during the 2003 invasion into Iraq. Two “thunder run” armored raids on Baghdad in early April 2003 stand out as relevant examples. The raids were launched because the 3rd Infantry Division (3ID), which spearheaded the invasion of Iraq only three weeks earlier alongside the 1st Marine Division, had established positions around the outskirts of

⁴³ Oleg Falichev, “‘There Is Not and Will Not Be Any Mercy for the Bandits,’ Lieutenant General Gennadiy N. Troshev Answers Krasnaya Zvezda’s Questions,” *Krasnaya Zvezda*, February 1, 2000, p. 1, cited in Thomas, 2000.

⁴⁴ Grau and Thomas, 2000.

Baghdad by the 2nd of April. The original plan for the invasion had the 3ID and Marines isolating Baghdad by surrounding it, assuming at some point that the Saddam regime would collapse. The armored raids carried out by the Second Brigade Combat Team (2BCT) of the 3ID, although not a part of the original operational plan, were ultimately designed to try to hasten that collapse by showing Iraqis in Baghdad and the remaining government officials that the United States could enter Baghdad at will.⁴⁵

Baghdad in April 2003 was a city of about 3 million people.⁴⁶ As Figure 3.3 illustrates, a large part of the city's population at the time was of the Shia sect and lived on the eastern side of the Tigris River in the Sadr City district. Saddam's Sunni sect made up certain key districts in the western half of the city; other districts in western Baghdad had districts with a mixture of Shia and Sunni sects.

The buildings in Baghdad were generally one- to three-story buildings, similar in certain ways to what the UN military forces faced in Mogadishu in 1993. The Karkh area abutting the western bank of the Tigris was the only area with tall skyscraper-like buildings. Although Baghdad, like the rest of Iraq, had modern infrastructure, the U.S. invasion in 2003, coupled with the previous decade of sanctions and sporadic U.S. air attacks, had destroyed much of the infrastructure.

In 2003, the enemy was a mix of Saddam regime paramilitary fighters (the fedayeen), who used guerrilla-like tactics to confront the Americans as they approached Baghdad. Combined with the fedayeen were remnants of the Iraqi Army that, unlike most of their brethren, had not simply melted away in the face of the U.S. onslaught. There were also a growing number of foreign fighters who came to Iraq to fight the Americans.⁴⁷ The enemy in Baghdad was in some ways similar

⁴⁵ Gregory Fontenot, E. J. Degen, and David Tohn, *On Point: The United States Army in Operation Iraqi Freedom*, Annapolis, Md.: Naval Institute Press, 2005, p. 336.

⁴⁶ Bruce R. Pirnie and Edward O'Connell, *Counterinsurgency in Iraq (2003–2006): Counterinsurgency Study—Volume 2*, Santa Monica, Calif.: RAND Corporation, MG-595/3-OSD, 2008, p. 41.

⁴⁷ Michael Gordon with Douglas Jehl, "After the War: Militants; Foreign Fighters Add to Resistance in Iraq, U.S. Says," *New York Times*, June 22, 2003; Pirnie and O'Connell, 2008, p. 9; and Fontenot, Degen, and Tohn, 2005, p. 152.

Figure 3.3
Baghdad Ethnic Breakdown in 2003

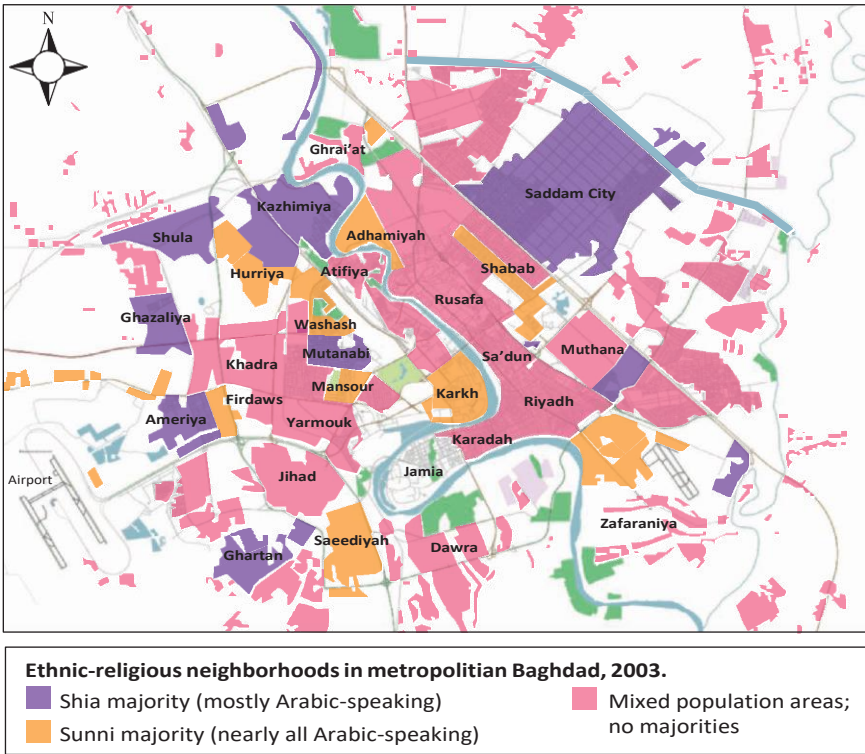

SOURCE: Michael Izady, *Atlas of the Islamic World and Vicinity*, Columbia University, Gulf2000 Program, 2006–present, II.A.3.

RAND RR1602-3.3

to what the Rangers and other UN forces faced in Mogadishu ten years earlier, in that they were mostly dismounted; used small arms, machine guns, and RPGs; and were able to emplace obstacles and mines on roadways. Unlike Mogadishu, however, in 2003 in Baghdad the population itself seemed mostly noncommittal and did not integrate into the fighting action as the Somalis did ten years earlier. It is also important to note that even though the enemy the 2BCT faced in the two Thunder Runs was made up of tenacious and at times competent fighters, it did not have an organized mechanized, armored defense.

The first armored raid occurred on April 5. It was carried out by a tank battalion task force with tanks, mechanized infantry and engineers, mortars, and other supporting elements. The unit's method was to move north toward Baghdad along Highway 8, then, once entering into the center of the city, to turn west along the airport road and eventually link up with another 3ID BCT guard at the large Baghdad airport complex. The aim was to test the defenses of Baghdad to see what kind of resistance the enemy would offer. The task force was trimmed down to bare essentials, only fighting elements with medical support – all other logistical elements were left behind. The April 5 raid encountered stiff resistance from dismounted fighters in dug-in positions using RPGs and machine guns. As the task force approached the southern edge of Baghdad, it received RPG fire and had one tank disabled and its tank commander killed. Even in the face of this resistance, the task force moved fairly easily on to its objective of reaching the airport.⁴⁸

The April 5 raid showed what an armored column in an urban environment moving quickly with protection and firepower could accomplish, especially against mostly light infantry defenders. One can imagine how that raid might have turned out with only light infantry mounted in thin-skinned Humvees. Instead of taking only about four hours to reach their objective, as the armored task force actually did, a light infantry force mounted in Humvees and supported by air and artillery would have invariably taken much longer and suffered much higher casualties. The nature of fighting and the amount of casualties would have been much different if the enemy had tanks and mechanized infantry fighting vehicles.

Based on the tactical success of the April 5 raid, a decision was made to launch another armored raid by 2BCT into Baghdad on April 7. But this time, instead of a raid that had a starting point within a friendly assembly area and an ending point in another friendly assembly area, the objective for the April 7 raid would be to pierce the heart of Baghdad by occupying the regime's key governmental facility in the city's center. The riskiest component of the raid was not so much

⁴⁸ RAND interview with General David Perkins, July 21, 2015; Fontenot, Degen, and Tohn, 2005, pp. 331–355.

reaching the city center and seizing it, but staying there and receiving resupplies on a route infested with light infantry fighters.⁴⁹

The BCT moved in a way that enabled its fighting battalions, consisting of tanks and mechanized infantry supported by mortars, engineers, and air and artillery fire support, to drop off company-size elements to secure the key points along the route. The lead task force departed at 6 a.m. in the morning and by 1 p.m. in the afternoon had its leading elements securing the key government buildings in the city center. One senior noncommissioned officer with prior experience in Mogadishu recognized that he needed more than a light-skinned Humvee for mobility, so he commandeered an armored recovery vehicle from the battalion maintenance point and used it to move around the battlefield.⁵⁰ After receiving positive reports from subordinate units, the BCT commander decided to stay. It was at that point that the removal of the regime had been made clear and the occupation of Baghdad and the rest of Iraq had begun.

The fighting that occurred on the second raid of April 7 confirms again the importance of armored forces using mobile protected firepower. The enemy resistance put up a defense similar to the way the Somali clansmen fought the Rangers and special operations forces in Mogadishu on October 3, 1993. Whereas in the latter the lack of armored forces created a problem that was in effect as large as the city itself, the armored raids in Baghdad on 5 and 7 April shrunk the problem down to manageable proportions.

It is important to note that, unlike in Grozny and Mogadishu, the enemy in Iraq did not take advantage of the urban terrain. Their defense appeared poorly coordinated and executed with defecting personnel, hastily laid mines, and roadblocks.⁵¹ Events unfolding in Sadr City five years later suggest that fighters in Iraq were learning how to leverage the urban terrain to greater effect, but so were U.S. and Iraqi partner forces.

⁴⁹ Fontenot, Degen, and Tohn, 2005, pp. 34–39.

⁵⁰ Perkins, 2015; Fontenot, Degen, and Tohn, 2005, pp. 351, 368

⁵¹ Fontenot, Degen, and Tohn, 2005, p. 352. See also Pirnie and O’Connell, 2008, p. 7.

4ID in Sadr City, 2008

The battle for Sadr City in 2008 was part of a broader surge aimed at establishing stability and security in Baghdad following the collapse of the Saddam Hussein regime. Major General Joseph Fil, Jr., commander of Multi-National Division–Baghdad (MND-B), outlined the overall plan in February 2007. The “Baghdad Security Plan” called for clearing out extremist elements entrenched in the districts surrounding Baghdad, followed by joint U.S./Iraqi patrols to maintain control of the streets, then a formal transition to Iraqi control, with U.S. continued assistance in reconstruction and development projects. The aim was to ensure that once security was established, the population would remain invested in the fledgling government’s new vision for Iraq.⁵²

Sadr City was a critical component of this strategy. Half the size of Manhattan, its streets were lined with machine shops, factories, and warehouses; buses, cars, and tractor trailers clogged passage in and around the city. The neighborhoods mainly consisted of two- or three-story buildings laid out in flat desert street grids and narrow alleyways. The Saddam government provided a minimal level of government services and had allowed militant groups and other criminal organizations to operate with impunity. Many of its 2.4 million people were impoverished, disenfranchised, and subjected to sectarian violence, rampant criminality, and corruption. Radical Shia leader Moqtada al-Sadr’s national political movement was an active participant in such illicit activities. Al-Sadr’s movement also spawned the paramilitary wing Jaish al-Mahdi (JAM). JAM filled the governmental void by adjudicating disputes, administering justice, and providing basic essential services. But those services came at a price, as al-Sadr’s organization employed its own brand of violence and crime to control the streets and intimidate the district’s inhabitants.⁵³

⁵² David E. Johnson, M. Wade Markel, and Brian Shannon, *The 2008 Battle of Sadr City: Reimagining Urban Combat*, Santa Monica, Calif.: RAND Corporation, RR-160-A, 2013, pp. 7–8.

⁵³ Johnson, Markel, and Shannon, 2013, p. 9; see also Christopher O. Bowers, “Future Megacity Operations – Lessons from Sadr City,” *Military Review*, May–June 2015, pp. 9–10; Michael Knights, “No Go No More: The Battle for Sadr City,” *Jane’s Intelligence Review*,

Al-Sadr also aimed to demonstrate his expanding influence. In March 2008, JAM forces overran a series of security checkpoints and fired an onslaught of rockets and mortars into the International (Green) Zone, home to national government offices and foreign embassies. The purpose was to challenge the authority of the national government and send a message that the new government was incapable of establishing and maintaining a secure and stable environment for the Iraqi people.⁵⁴

On March 25, the al-Maliki government authorized U.S. and Iraqi forces to stop the rocket attacks and defeat the militants in Sadr City. Colonel John Hort, commander of the 3rd Brigade Combat Team, 4th Infantry Division (3-4 BCT), developed a course of action that aimed to clear and hold enemy launch sites. The original operational concept envisioned a combined arms maneuver campaign employing Stryker light infantry forces supported by an employment of technological assets.⁵⁵

As Figure 3.4 illustrates, 3-4 BCT and Iraqi elements drawn from its 11th Division ground maneuver units set up a forward defense in the southern quarter of the city as part of “Operation Striker Denial” to stop mortar and rocket fire on the Green Zone further south. The Green Zone was at the maximum range of JAM’s weapons. Pushing back the group’s area of operations would therefore significantly reduce the effectiveness of their attacks. U.S. forces had to consider the enemy’s capabilities (automatic weapons, .50-caliber sniper rifles, improvised explosive devices [IEDs], RPGs, and SA-7 portable air defense systems) and how the city’s urban terrain facilitated the group’s operations.⁵⁶ While armored combat platforms afforded significant lethality, survivability, and mobility, the urban terrain proved formidable. The 3-4 BCT carried out initial engagements in Stryker vehicles (medium armored forces), but these vehicles, with their lack of armored protection, fell victim to RPG attacks launched from the city’s low-rise build-

Vol. 20, No. 7, July 2008; and International Crisis Group, *Iraq’s Civil War, the Sadrists and the Surge*, Middle East Report No. 72, February 7, 2008, p. 6.

⁵⁴ Knights, 2008.

⁵⁵ Johnson, Markel, and Shannon, 2013, p. 24

⁵⁶ Johnson, Markel, and Shannon, 2013, p. 47.

Figure 3.4
Sadr City

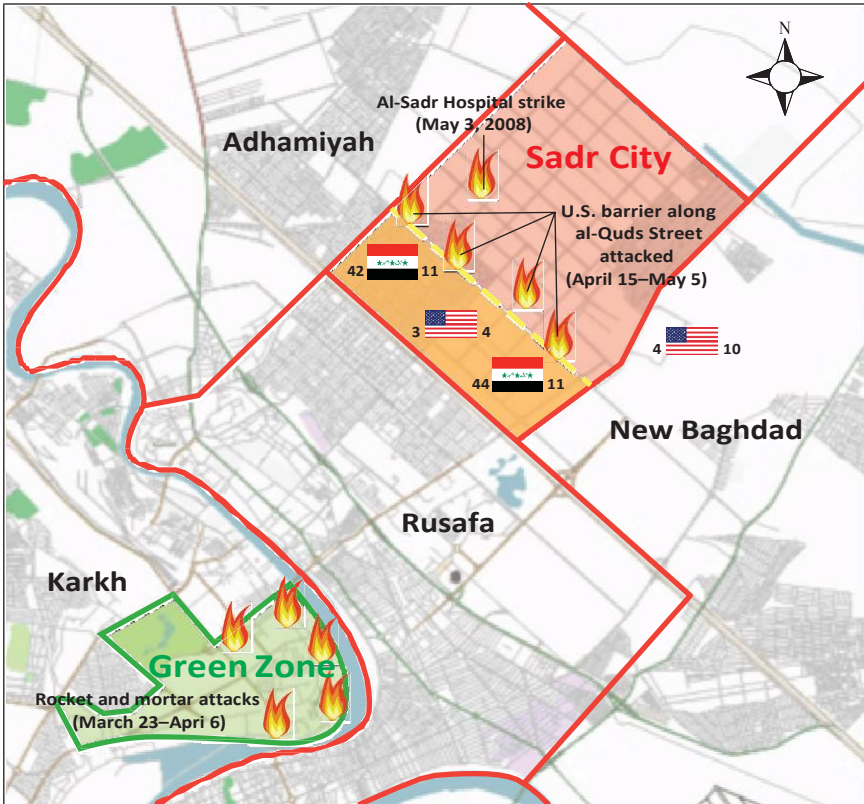

SOURCE: David E. Johnson, M. Wade Markel, and Brian Shannon, *The 2008 Battle of Sadr City: Reimagining Urban Combat*, Santa Monica, Calif.: RAND Corporation, RR-160-A, 2013.

RAND RR1602-3.4

ings and IEDs hidden under trash-piled streets. The city’s small, cluttered alleys also significantly restricted the movement of the Stryker vehicles, which have a wide and large turning radius.⁵⁷ The 1st Squadron, 2nd Stryker Cavalry Regiment (1-2 SCR) lost six Stryker vehicles

⁵⁷ Johnson, Markel, and Shannon, 2013, p. 20.

within the first week of the fight.⁵⁸ U.S. forces brought in M1 Abrams tanks and M2 Bradley fighting vehicles that survived the IED and RPG assaults.⁵⁹

To make up for some of these weaknesses, the operation took advantage of significant leaps in technological advancements. These advances featured around-the-clock access to pervasive intelligence, surveillance, and reconnaissance (ISR) and precision-strike capabilities, including armed and unarmed unmanned aerial systems (UASs), Apache attack helicopters, close air support (CAS), and guided multiple launch rocket systems (GLMRSs).⁶⁰ To improve the operational responsiveness and deployment of weapons, the division headquarters pushed control of these assets down to the brigade level of command.⁶¹ This operational-level decision enabled the BCT staff to integrate and disseminate information to operational units in time to find, fix, and finish time-sensitive targets.

The brigade also reinforced its efforts by employing 500-pound guided bombs to destroy buildings that sheltered snipers. While somewhat effective, the unit recognized the need to avoid collateral damage in the densely populated city and shifted course to seal off and deny militant access to this terrain altogether.

Between April and May 15, U.S. commanders initiated “Operation Gold Wall,” which tasked ground units to construct a 12-foot concrete barrier the length of the southern route into the city. The aim was to deny JAM forces the ability to access the population and to prevent the area’s use as a rocket-launching site capable of ranging the Green Zone.⁶²

⁵⁸ Johnson, Markel, and Shannon, 2013, p. 57.

⁵⁹ Johnson, Markel, and Shannon, 2013, pp. xvi-xvii. For an excellent analysis of recent Israeli experience in combat operations, see David E. Johnson, *Hard Fighting: Israel in Lebanon and Gaza*, Santa Monica, Calif.: RAND Corporation, MG-1085-A/AF, 2011.

⁶⁰ Bowers, 2015, p. 14.

⁶¹ Knights, 2008. See also Johnson, Markel, and Shannon, 2013, p. vi.

⁶² Michael Gordon, “U.S. Begins Erecting Wall in Sadr City,” *New York Times*, April 18, 2008; and Johnson, Markel, and Shannon, 2013, p. 71.

The rocket launchers themselves were defeated by a tightly integrated air-ground-ISR system that was unprecedented in the capabilities that were given to a BCT. Figure 3.5, a slide from a briefing General David Petraeus used to discuss the battle of Sadr City, shows these resources.

It soon became apparent that JAM viewed the market areas that would be denied them as key terrain, and its fighters came out and contested the wall. Heavy armor provided fire protection for soldiers and large construction equipment as the project “became a magnet

Figure 3.5
ISR and Strike Assets Employed in the Battle of Sadr City

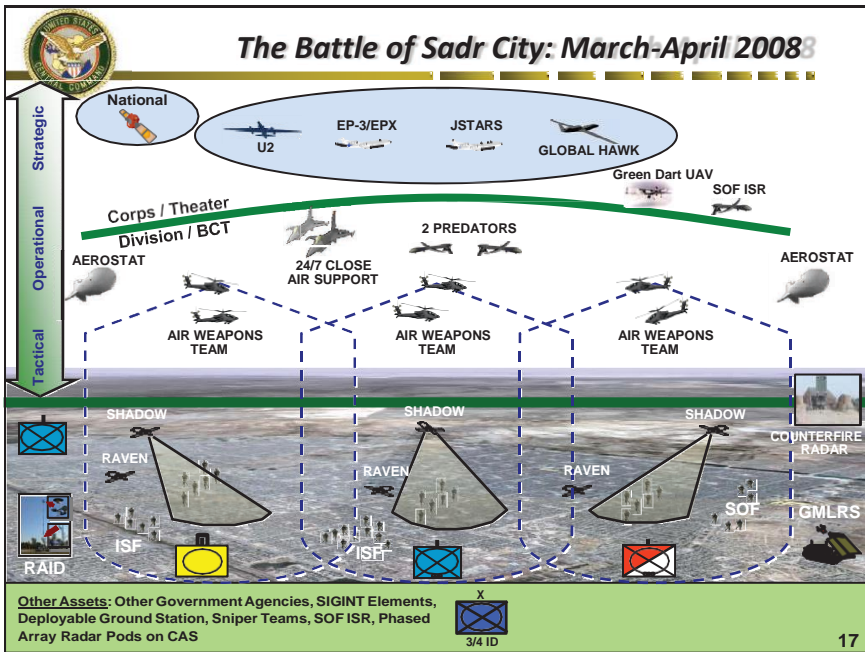

SOURCE: David H. Petraeus, “CENTCOM Update, Center for a New American Security,” briefing, 2009.

NOTES: GMLRS = guided multiple launch rocket system; ISF = Iraqi security forces; JSTARS = Joint Surveillance Target Attack Radar system; RAID = Rapid Aerostat Initial Deployment; SIGINT = signals intelligence; SOF = special operations forces.

for every bad guy in Sadr City.”⁶³ Thus, a secondary consequence of the wall’s construction was that it drew out the enemy, enabling U.S. forces already in place to fight from a position of advantage. Forcing the enemy to come out and fight a newly tailored U.S. combat force that had mobile protected firepower essentially shrunk the problem down to manageable proportions. Bringing in armored forces, once it was realized that Strykers and light infantry were taking unacceptably high casualties, enabled the U.S. task force to survive the enemy’s attacks while at the same time applying withering and lethal firepower.

Another indication that the wall was having the intended effect was a flood of reliable information about the enemy from the local population, seemingly indicating they felt confident that U.S. and Iraqi soldiers were shifting momentum in their favor.⁶⁴ The information proved essential for locating IED emplacements and identifying and locating remaining leaders.

By mid-May, the threat from al-Sadr’s militant arm had largely been neutralized. Relentless pressure from U.S. and Iraqi forces had taken its toll on JAM fighters, who were showing up in ever-decreasing numbers. On May 11, 2008, al-Sadr requested a ceasefire, but not before an estimated 1,000 fighters lost their lives and much of JAM’s leadership fled the country. While pockets of resistance remained, the halt in large-scale violence made it possible for the government to focus on reconstruction efforts and win the hearts and minds of its own population.⁶⁵

The battle for Sadr City illuminates a number of key insights regarding the effectiveness of armored/mechanized forces and light infantry in urban combat. For one, armored/mechanized forces alone do not guarantee success. The densely populated urban sprawl necessitated striking the right balance between armored/mechanized and light infantry forces. The city’s narrow streets and low-level buildings gave JAM militants a tactical advantage against armored or mecha-

⁶³ Johnson, Markel, and Shannon, 2013, p. xvii.

⁶⁴ Johnson, Markel, and Shannon, 2013, p. 84.

⁶⁵ Mohammed Tawfeeq and Jomana Karadsheh, “Cease-Fire Reached in Baghdad’s Sadr City,” *CNN*, May 11, 2008.

nized vehicles. On the other hand, the city's lack of vegetation allowed U.S. forces to exploit technological advancements that provided a unique aerial lens from which to observe and strike the enemy with precision. The operational decision to push those capabilities down to lower levels of command increased responsiveness. Intelligence gleaned from the local population facilitated target discrimination. This intelligence from the local population may have proved difficult to obtain if operations had resulted in mass casualties or otherwise disrupted daily life in a bustling city with millions of residents with nowhere to go.

The construction of the wall required soldiers on the ground to build it and armor to protect it. As the wall became firmly established, JAM found itself cut off from key launching positions and critical sources of revenue. The barrier literally put JAM forces between a rock and a hard place. If they allowed it to stand, they could not bring their indirect fire systems in range to attack the Green Zone. But if they attacked the wall and its builders, they then confronted U.S. tanks and Bradleys, thereby making them highly susceptible to destruction by American armored and mechanized vehicles. In the end, U.S. and Iraqi forces successfully navigated the complex, urban terrain by employing combined arms with flexibility, ingenuity and fluidity.

It is important to note that many of the things that are often thought to have originated with the Surge had been in place in U.S. Army units in Baghdad in the preceding two years. For example, the walling off of Baghdad districts to lessen the violence caused by the Sunni-Shia civil war had already occurred in the Baghdad districts of Dora and Amiriya. Moreover, the focus on protecting the population – a key theoretical tenet of population-centric counterinsurgency – was also a basic premise to most operational units in Baghdad prior to the Surge.

What changed with the Surge was the addition of five brigades, which produced a significant increase in tactical fighting power and were used in combination with other factors, such as improved Iraqi security forces capabilities and the spread of the Anbar Awakening, to capture or kill al Qaeda fighters and recalcitrant Shia militiamen, among other important conditions. The combination of these condi-

tions with the additional capacity of the five Surge brigades produced a controlling effect on the Baghdad population.⁶⁶

The Battle for Sadr City yielded several key insights that have yet to be fully institutionalized by the Army. These were elaborated in the RAND report *The 2008 Battle of Sadr City: Reimagining Urban Combat* and remain relevant.⁶⁷ Excerpts from pp. 106–110 of that report appear below and on the following pages, ending at the section titled “Key Insights and Findings from Case Studies.”

Protecting the Population Requires a Balance Between Offensive, Defensive, and Stability Operations

Counterinsurgency doctrine accords tremendous importance to protecting the population. Some analysts posit a tension between this end and offensive combat operations. The Surge, the Baghdad Security Plan, and the 2008 Battle of Sadr City indicate that this tension might be more apparent than real. In Sadr City, JAM was the source of insecurity. . . . JAM’s conduct was causing the population under its control to become somewhat restive. As long as JAM maintained a monopoly of violence in Sadr City, however, the population would continue to render tangible, if reluctant, support. JAM managed to intimidate or corrupt Iraqi security forces sent to confront them. Providing security to Sadr City’s population was not possible until JAM was defeated. After JAM’s defeat, the Iraqi Army’s 44th Brigade was able to extend government control throughout Sadr City. U.S. and Iraqi forces exploited their victory to further disrupt and dismantle insurgent networks in the meantime.

Persistent ISR, Technical Intelligence, and Precision-Strike Capabilities Enable the Attacker to Seize the Initiative

Persistent ISR, technical intelligence, and responsive precision-strike capabilities (afforded by attack helicopters, fixed-wing CAS, UASs,

⁶⁶ For a sense of what the Battle of Sadr City was like for U.S. Army infantry soldiers, see Konrad R.K. Ludwig, *Stryker: The Siege of Sadr City*, La Cañada Flintridge, Calif.: Roland-Kjos, 2011.

⁶⁷ Johnson, Markel, and Shannon, 2013.

and GMLRS) were fundamental to success and must be integrated. To be absolutely clear, coalition forces could not have achieved the same results at the same cost without these capabilities. Political constraints . . . precluded U.S. ground maneuver operations beyond Route Gold. More importantly, the demands of combat in Ishbilyah and Habbibiyah to seize the rocket sites indicate that even if the al-Maliki government had relaxed its ban on U.S. ground operations north of Gold, such operations would have required a lot more forces. [Multi-National Force-Iraq] would have been forced to reallocate maneuver forces from other priority efforts, which was precisely the effect that JAM was trying to achieve. Aerial strike and ISR did not win the battle by themselves, but 3-4 BCT could not have won the battle without them.

Integrating airborne ISR and precision-strike assets into ground operations in urban environments presents significant airspace C2 challenges. Multiple aerial platforms and means of direct and indirect fire are being employed in a relatively small area of operations. Air traffic controllers and fire support coordinators require training in this complicated and important context. At the time, the level of support 3-4 BCT received was unprecedented.

The Army has recognized the importance of increasing its organic ability to provide sustained aerial ISR to unit commanders and is taking steps to meet those needs. The Army is already taking steps to augment its airborne ISR and precision-strike capabilities. Army combat aviation brigades now include 12MQ-1C "Gray Eagle" extended-range multipurpose unmanned aerial systems. The Gray Eagles are the equivalent of the armed Predator employed in this battle.

Nonetheless, these assets are key in showing proportionality and deliberateness, in attacking targets "among the people" with low collateral damage, and in reducing soldier exposure to the risks of urban combat. MND-B's public affairs officer and its information operations officer believed that their ability to demonstrate this level of precision and proportionality using actual video footage helped avert or contain public anger.

Finally, relatively large guided bombs (500 pounds or larger) released from fixed-wing aircraft are needed to destroy some categories of urban targets (e.g., multistory buildings). This need occurred rela-

tively rarely during the battle, but was important when it did. In particular, snipers in one five-story building overlooking Route Gold significantly slowed progress on the wall, while the structure itself seemed to provide adequate cover and concealment from the BCT's organic weapons. After several days, units were finally authorized use of a Joint Direct Attack Munition to demolish the building.

Technical Capabilities Must Enable Decentralized Decisionmaking and Small Unit Initiative

The enemy is fleeting, which means that decentralized decisionmaking is required. Units at the brigade level and below must therefore have access to the information and other capabilities required to support the rapid decisions necessary to deal with a highly mobile enemy (who understands his own vulnerabilities) and to enable effective, independent action. Some gaps remain in getting "ISR to the objective" companies and possibly platoons require access to SIPRnet traffic but have a hard time getting it. Current operations have yet to truly stress extant capabilities in a dynamic environment. Platoon leaders and subordinate element leaders still had to rely on voice descriptions of the objectives and activities taking place there during raids conducted before and after the battle. They had to depend on the battalion tactical operations center or tactical command post to interpret video feeds for them.

Isolating the Enemy Enables the Counterinsurgent to Seize the Initiative

The guerrilla or insurgent depends on mobility. Mao's aphorisms frequently refer to the importance of mobility, directing the guerrilla to withdraw when the enemy is stronger, or noting that the population is the "sea" through which the guerrilla fish "swims." Mobility and concealment allow the insurgent to counter the state's advantages in material and mass by striking vulnerable points at a time of the insurgent's choosing. As long as the insurgent retains the initiative, it can be said that as long as he is not losing, he is winning.

Isolating areas of operation deprives the insurgent of his advantages of mobility and concealment. Even before the Battle of Sadr

City, 2-82 BCT's operations during the surge deprived al-Qaeda in Iraq the ability to inflict mass casualties and fuel the burgeoning civil war. 2-82 BCT's primary tool in this effort was the concrete T-wall. Attempting to cross these barriers only made insurgent leaders visible. If they tried to hide, it was just a matter of time before coalition forces located them and killed or captured them. These tactics contained, and then neutralized, the Sunni insurgency. Before the battle, they also disrupted JAM's leadership structure. Finally, in cutting JAM off from its lifeline in the Jamiliyah Market, the Gold Wall forced the enemy to fight or wither on the vine. Concrete enlisted time on the side of the counterinsurgent.

Ground Maneuver Remains Indispensable for Shaping the Battle and Achieving Decision

We have already noted that 3-4 BCT and MND-B could not have achieved the same favorable outcome at a similar cost without heavy reliance on aerial ISR and strike. Ground maneuver was equally essential to coalition success in the Battle of Sadr City. Aerial ISR and strike were successful because they only had to control a portion of the area of operations, the area within 107mm rocket range of the Green Zone but beyond Route Gold. Superiority in ground maneuver not only enabled the BCT to seize the launch sites in Ishbiliyah and Habbibiyah, but was also essential in enabling 3-4 BCT to seize control of the fight from JAM. Finally, we should note that it was the ground maneuver fighting along the wall that largely destroyed JAM's military capability.

Building the wall along Route Gold was an integral part of ground maneuver. It severely restricted the enemy's ability to employ indirect fire; forced enemy fighters to respond to the increasing isolation that the Gold Wall, if finished, would cause; and separated the adversary from the population.

Heavy Armored Forces Have Enduring Utility in Counterinsurgency and Urban Operations

Armored forces – i.e., tanks and infantry fighting vehicles – are key elements of maneuver in complex terrain. In the Battle of Sadr City, armored forces included Abrams tanks, Bradley Fighting Vehicles, and

Stryker armored vehicles. Each system had its advantages and disadvantages, and each complemented the others. Initially, 1-2SCR suffered heavily from explosively formed penetrators (EFPs) and other anti-armor systems, and found itself struggling harder to attain tactical overmatch in intense combat. Augmenting its force with tanks and Bradley Fighting Vehicles provided that degree of tactical overmatch, as demonstrated by B/1-2SCR's battle to seize Named Area of Interest (NAI) 608. On the other hand, the tanks and Bradleys needed overwatch and security from the dismounted infantry the Strykers carried. Armored combat vehicles are survivable, lethal, and precise. Additionally, and perhaps somewhat counterintuitively, they often cause less collateral damage than an artillery or CAS strike. The protection provided by their armor allows soldiers to be careful and precise about selecting and engaging their target.

Integrating SOF into Conventional Operations Achieves Synergy

Conventional forces benefited significantly from SOF actions before, during, and after the battle. Special operations forces provide unique capabilities to exploit intelligence to kill or capture insurgent leaders. As we have observed, JAM actions during the battle were frequently ill-conceived and ill-coordinated, contributing to the speed and thoroughness of coalition success.

Snipers Remain an Important Enabler in Urban Operations

Snipers are important assets in urban operations. They are key assets, particularly in countersniper operations and for intelligence collection. In the battle of Sadr City, SOF snipers played critical roles suppressing enemy snipers during the construction of the Gold Wall. Conventional snipers at the battalion and company levels played a similar role in providing overwatch to company operations. As TF 1-6IN found, they were also extremely useful in a passive surveillance role. We should also mention the important role snipers played in training the BCT's route clearance company. The engineers found the training they had received from snipers in scanning for anomalies to be by far the most useful capability they had to detect IEDs and EFPs.

Enduring Success Depends on Capable Indigenous Security Forces

The ultimate success of the operation depended on capable Iraqi security forces. If the 44th Brigade had not been capable of securing Sadr City north of Route Gold, JAM could simply have reconstituted in this sanctuary and resumed its belligerent behavior in a few months.

Developing capable indigenous forces takes time; 3-4 BCT was fortunate that years of U.S. efforts in this arena were beginning to bear fruit. For example, several of the more successful junior leaders during the 44th Brigade's attack to Route Gold were graduates of the Iraqi military academy. It also took time for aggressive, aware leaders like General X [Commander, 42nd Brigade of the Iraqi Army] to emerge. Likewise, without the experience of managing a "checkpoint Army," it seems doubtful that the Iraqis could have moved on to the more challenging task of offensive operations. Capable indigenous security forces are indispensable for securing gains. In the case of Iraqi security forces, it took some time for them to develop competence. Until they did, coalition forces had to both train them and shoulder the bulk of the security challenges.

Urban Counterinsurgency Requires Forces to Transition Rapidly Between Offensive, Defensive, and Stability Operations

A force capable of rapid transitions is important. Soldiers in 3-4 BCT were executing population-centric counterinsurgency before the battle of Sadr City. They rapidly transitioned into conducting high-intensity, decentralized, close combat operations. The most time-consuming part of the transition was TF 1-68's retrieval of its tanks and Bradley Fighting Vehicles from the U.S. base at Taji. Its pre-deployment training activities, which had emphasized traditional combat operations, probably helped in this transition. That emphasis is not necessarily a template for the future, since it implicitly depended on the experience unit leaders had already acquired in counterinsurgency in Iraq. After al-Sadr declared a truce on May 12, 2008, U.S. forces again shifted their emphasis to counterinsurgency and stability operations. What we can say is that leaders must understand the likelihood of such transitions and balance their preparations accordingly.

Key Insights and Findings from Case Studies

Although these four case studies span very different sets of conditions in terms of the types of urban environments confronted, enemy forces involved, and missions and political context of the military forces involved, several key findings emerge.

All four cases show the importance of ground forces having mobile protected firepower when conducting urban operations. In Mogadishu, the Ranger and special operations raid was severely handicapped without such firepower, and if the Rangers' mounted extraction force had armored vehicles instead of thin-skinned Humvees, the high numbers of casualties actually taken would have been far less. Grozny I also highlights that mobile protected firepower alone is not a guarantor of success, since those capabilities must also be combined with well-trained and well-led units with creative solutions to operational problems. And Grozny II shows that even with improved mobile protected firepower capabilities, the Russian Army chose to remain largely on the outskirts of the city and then reduce the operational problem with firepower. The April 2003 3ID armored raids into Baghdad and the 2008 Battle of Sadr City show that the advantage mobile protected firepower gives to the ground force is the potential of overmatch against an enemy force; if applied correctly, mobile protected firepower can also give freedom of movement.

Armored ground forces' ability to provide freedom of movement in an urban area provides the basis for shrinking the operational problem of a large urban area down to a neighborhood. However, the key ingredient for an operational solution that shrinks the problem is creative thinking by military leaders who can think outside of established methods and norms of operations. Part of the problem for TF Ranger in Mogadishu, beyond the earlier request that senior American military leaders on the ground had made for an armored task force, was that the special operations leadership had become used to a pattern of operations that they assumed would be sufficient for the October 3 raid. They did not imagine the possibility of the need for quick-responding armored forces and failed during their planning process to ask Pakistani armored forces to be prepared to assist them. If Moga-

dishu demonstrates a failure of creative thinking, the April 5 and 7, 2008, Baghdad armored raids by 3ID and the 2008 Battle of Sadr City show the advantage of combining creative operational thinking with a force premised on mobile protected firepower.

All four cases also show that policy ultimately shapes military operations to varying degrees, and planners conceiving of operations in urban environments must take policy into account. The case of Mogadishu is a good example of how the senior U.S. commander had identified the need for additional armored forces; however, U.S. policy objectives emphasized downsizing U.S. presence and a speedy withdrawal. At the same time, operationally the objective was to degrade the effectiveness of militia clansmen by increased combat operations. This contradiction between policy goals and operational method was laid bare by the Ranger raid debacle on October 3.

If not understood in this way, the U.S. Army might conclude that mobile protected firepower in its current form – centered on the M1A2 main battle tank and the Bradley infantry fighting vehicle – is sufficient to confront the battlefields of today and in the future. Or it might similarly conclude that armor and infantry will cooperate in the same way and use the same tactics as they did in Fallujah and Sadr City. While mobile protected firepower is a necessary baseline premise for the Army in the future, the Army must consider the changing nature of current combat operations when thinking about how mobile protected firepower should be employed, the combat vehicles and weapons systems involved, and even its organization.

Lastly, these four cases are important for the insights and lessons that they do not provide. Namely, in the three cases where ground forces were relatively successful – Grozny II, Baghdad in 2003, and Sadr City in 2008 – the enemy was primarily a light infantry-centric force with varying degrees of C2, training, and types of handheld anti-armor weapons and firepower. What none of these cases shows is a ground force confronting an enemy force in an urban environment that is premised on mobile protected firepower and has sophisticated C2 and well trained forces. Current Russian operations in Ukraine suggest what kind of enemy force this might pose. Thus, a useful way to understand the past through the prism of contemporary combat

operations is to consider potential Russian aggressive activities in the Baltics, based on the fighting capabilities they and their proxies have displayed since 2013 in Ukraine.

Understanding the Past Through the Prism of the Present: Current Russian Combat Operations in Ukraine

NATO allies have expressed concern over recent statements by President Vladimir Putin asserting that Russian forces could invade Poland, Romania, and the Baltics, reaching cities such as Riga, Latvia, in a mere two days.⁶⁸ One hypothetical scenario that contemporary analysts have offered has been for the United States and other NATO allies to not defend forward along the borders, but instead defend from major urban areas such as Riga.⁶⁹ In this way, the Russian ground assault would have to fight it out in a few major urban areas, slowing their momentum down and potentially causing very high casualties.

Urban defensive operations are particularly relevant in the Baltics as a means to deter potential Russian aggression. As RAND analyst David Ochmanek, following a series of wargames centered on the Russian challenge in the Baltics, noted: “We can defend the capitals, we can present Russia with problems, and we can take away the prospect of a *coup de main*.” In short, U.S. and NATO forces could create conditions in urban areas in the Baltics that make it impossible for the Russians to overrun them rapidly, thus removing the possibility of a *fait accompli* and thereby changing their risk calculation to preclude assumptions of an early, cheap success.

Recent actual combat in Ukraine against invading Russian and proxy forces provides more than theoretical indications of what U.S. Army forces might confront in potential future conflict in eastern Europe. Fighting in Ukraine shows some important changes in the nature of high-intensity combat that the U.S. Army should be paying

⁶⁸ Justin Huggler, “Putin ‘Privately Threatened to Invade Poland, Romania and the Baltic States,’” *The Telegraph*, September 18, 2014.

⁶⁹ Kelly, 2015.

attention to. Like the paradigmatic shift in U.S. Army thinking about combat after the 1973 Yom Kippur War, in which anti-tank weaponry enabled infantry to destroy tanks at ranges out to 4 to 5 kilometers, similar paradigmatic changes have occurred during Ukrainian combat.⁷⁰ The changing trends in warfare coming out of Ukraine should cause the U.S. Army to consider important adjustments to its fighting doctrine, organizations, and weapon systems.

The first important changing trend is the ubiquitous amount of UASs over the battlefield. UASs in combat have been prevalent for the past decade, in the American wars in Iraq and Afghanistan and in other Middle East conflicts. What is different about UAS usage in Ukraine is that the air space over the battlefield, especially at higher levels, is heavily contested, with various types of air defense weapons systems making manned aircraft too risky to fly. Although the Russians have not flown any UASs that have attack capabilities like the United States' Raven UAS, they have been quite effective at combining more than 14 different types flying at different altitudes with strike capabilities that include rocket, mortar, and artillery systems. This combination has enabled the Russians to mass indirect fires against Ukrainian ground combat forces with quite lethal effects.⁷¹

The second important change occurring in the Russo-Ukrainian War is the high lethality of artillery fire, especially by the Russian Army and its Ukrainian proxies. Whereas the United States and many of its NATO allies have been moving away from massed field artillery toward precision-strike artillery, such as the American-made "Excalibur" precision artillery munition rounds, the Russian Army over the past two decades has trended in the opposite direction, toward massed rocket and tube artillery fire. The Russians and their proxies in Ukraine have been using multiple rocket launcher artillery to fire high explosives, scatterable mines, and thermobaric munitions. The effects of this

⁷⁰ Robert A. Doughty, *The Evolution of U.S. Army Tactical Doctrine: 1946–76*, Fort Leavenworth, Kan.: U.S. Army Command and General Staff College Press, 1979, p. 41.

⁷¹ For a detailed discussion of Russian and Ukrainian UAS employment, see Karber, 2015, pp. 12–15. See also Syndey Freedberg, "Russian Drone Threat: Army Seeks Ukraine Lessons," *Breaking Defense*, October 14, 2015.

massed artillery have been telling: There are recorded cases where it has destroyed entire Ukrainian mechanized battalions caught in the open in a manner of minutes. Artillery has also been reported to have been used innovatively as a direct counter fire to anti-tank guided missiles (ATGMs) launched by the Ukrainians at Russian tanks.⁷²

The 1973 Yom Kippur War signaled the lethality of infantry wielding ATGMs that could destroy main battle tanks out to 4 to 5 kilometers; the current fighting in Ukraine is turning this innovation on its head. Main battle tanks such as the T72B3s and T80s used by the Russian Army and its separatist proxies have sophisticated ERA, which nullifies the killing effects of infantry-held ATGMs, such as RPG 7s and RPG 26s. Although the American TOW II and Javelin anti-tank missiles with their tandem explosive charges would defeat Russian armor, the United States has denied them to the Ukrainian Army.⁷³

Combined with the loss of effectiveness of infantry-launched ATGMs in Ukraine is the readily apparent inability of infantry fighting vehicles (IFVs) without reactive armor to survive on the battlefield (Ukrainian villages have even resorted to improvised modifications on civilian vehicles, turning minivans into makeshift armored vehicles).⁷⁴ Combat in Ukraine has increasingly emphasized that IFVs such as the BMP-1, BMP-2, and BTR cannot survive on a high-intensity battlefield; they are simply too vulnerable to tank main gun direct fire (again highlighting the fact that Russian tanks in Ukraine are not vulnerable to infantry-launched ATGMs) and equally vulnerable to massed Russian artillery fire. The resultant effect has been to detach Ukrai-

⁷² Karber, 2015, pp. 16–21. See also N. R. Jenzen-Jones and Jonathan Ferguson, “An Examination of Arms & Munitions in the Ongoing Conflict in Ukraine,” *Armament Research Services*, Research Report No. 3, 2014, p. 71; Tom Parfitt, “Ukraine Promises ‘Retribution’ as at Least 19 Soldiers Killed in Rebel Rocket Attack,” *The Telegraph*, July 11, 2014; BBC, “Ukraine Conflict: Many Soldiers Dead in ‘Rocket Strike’ *BBC News*, July 11, 2015; and TotalWarTV, “Pro-Russian Rebel Tank Hit by Ukrainian Army ATGM,” June 8, 2015.

⁷³ Karber, 2015, pp. 22–26. See also Sohrab Ahmari, “An S.O.S. from Battleground Ukraine,” *Wall Street Journal*, July 29, 2015; Peter Laurence, “Ukraine ‘Can’t Stop Russian Armour,’” *BBC News*, February 6, 2015.

⁷⁴ Jenzen-Jones and Ferguson, 2014, p. 80.

nian mechanized infantry from Ukrainian armor and deprive the latter from needed infantry support to protect against Russian infantry.⁷⁵

Implications for the Future

Distilling the lessons for the Army and the joint force in defensive operations is a strategic and cultural challenge. The challenges of deploying significant forces to places in the world where they can deter aggression – e.g., the Baltics – are formidable, as are the advanced anti-access and area denial (A2AD) capabilities they will confront. These forces need sufficient defense capacity and capability to present a high enough risk of failure to an aggressor. The question that needs to be asked and answered is this: What is the best option to deter aggression? Defending key urban areas to the degree that they cannot be rapidly overwhelmed, as noted earlier, precludes a quick victory by an adversary. This may be sufficient in and of itself to deter aggression.⁷⁶

Our analysis of the four case studies seen through the prism of current combat operations in the Russo-Ukrainian War indicate that while mobile protected firepower in urban operations is still a valid premise for the U.S. Army, it is not enough. Instead, the U.S. Army needs to think through how it can adapt and modify the force across DOTMLPF with the lessons of the past in mind but with a clear eye to what future urban combat potentially holds. The detailed analysis of the Second Battle of Fallujah in the next chapter further supports the point.

⁷⁵ Karber, 2015, pp. 26–29.

⁷⁶ For a discussion of the strategic challenges posed by Russian aggression, see Olga Olikier, Michael J. McNerney, and Lynn E. Davis, *NATO Needs a Comprehensive Strategy for Russia*, Santa Monica, Calif.: RAND Corporation, PE-143-OSD, 2015.

Striking the Right Balance: A Comparative Analysis of Light and Mechanized Infantry in the Second Battle of Fallujah

Introduction to Comparative Analysis

Most published accounts of the Battle of Fallujah describe what happened over time and by events. They offer detailed descriptions of the course of the battle and the heroism of the men and women who fought and took part in it; they create in the minds of the reader the challenges and difficulty of battle, or, more simply put, they tell a story of war.¹ But they largely stop there.

Few ask hard analytical questions about Fallujah. Did the casualties that occurred during the battle happen during hours of daylight or darkness? Why did certain units involved in the battle take higher casualties than others? Were these higher casualties a result of poor tactical planning, fighting methods, higher concentrations of enemy, just bad luck, or some combination of these various factors? If combined arms played an integral role in the fight, what were the strengths and weaknesses between mechanized armored infantry and light infantry? Were they combined effectively, and if not, how could have it been

¹ See for example: Richard Lowry, *New Dawn: The Battles for Fallujah*, New York: Savas Beatie, 2010; Dick Camp, *Operation Phantom Fury: The Assault and Capture of Fallujah, Iraq*, Minneapolis, Minn.: Zenith Press, 2009; Gary Livingston, *Fallujah With Honor: First Battalion, Eight Marine's Role in Operation Phantom Fury*, New York: Caisson Press, 2005; Patrick K. O'Donnell, *We Were One: Shoulder to Shoulder with the Marines Who Took Fallujah*, Philadelphia, Pa.: Da Capo Press, 2006; and Bing West, *No True Glory, A Frontline Account of the Battle for Fallujah*, New York: Bantam Publishers, 2006.

done better? How were other arms combined, such as engineers, air and indirect fires, with tactical methods on the ground? Which types of mounted and dismounted movement techniques were more prone to taking casualties? Which tactical methods worked and did not work for both armored mechanized infantry and light infantry?

The following case study on the Second Battle of Fallujah – also known as Operation al Fajr – in November 2004 provides this level of analytical detail. It begins with a historical narrative of the battle, then digs into the details of the fight to glean analytical insights about the challenges of fighting in urban combat. As an analytical tool, the research team developed a database of the casualties incurred during the conflict. The data were compiled from primary and secondary resources and capture such nuances as the time of day of the casualty, the location, the ranks and units (USMC or Army) involved, and the type of attack (IED, grenade, RPG, etc.) that led to the casualty. Although close analysis of casualties is just one way of analyzing military effectiveness in battle, it can be a very useful way for the following reasons. First, the published secondary accounts described above tend to weave their narratives around the taking of casualties because they offer opportunities for writers to highlight the intensity of battle and the heroism often displayed when casualties occurred. Since many of the available published sources rely on interviews of participants in the battle, the descriptions of casualties in terms of time, space, and enemy action are especially helpful. The second and arguably more important reason to use casualties as a tool for comparative analysis of light and mechanized infantry in Fallujah II is that it is in the taking of casualties where such things as friendly movement, enemy action, etc., come into sharp relief, exposing strengths and weakness and thereby allowing for critical analysis.

A few caveats are in order, however. If the fog of war makes battlefield conditions chaotic and confusing, it is no better friend to the analyst attempting to make sense of it long after the fact.² Over the course of the past decade, different historical accounts have provided different

² For the challenges of writing military history and the difficulty of battle analysis, see John Keegan's still highly useful and relevant *The Face of Battle* (New York: Viking Press, 1976).

levels of detail, varying accounts of when, where, how, and how many casualties occurred. There are good reasons for this. Military personnel engaged in combat are far more concerned with killing the enemy and living to tell about it than documenting the event in rigorously accurate detail. Casualties were also likely underreported because many of the Marines, soldiers, seamen, and airmen sent to Fallujah did not report minor injuries for fear of being taken out of the fight.³ Only the more severe injuries requiring medical evacuation would be noted, and even in those cases some soldiers had to be ordered off the battlefield before they complied. Additionally, an officer or senior enlisted man being wounded tends to be more disruptive to the unit and so is more likely to be remembered and commented on in a memoir than lower-ranking personnel. As a result, the data compiled most likely overrepresent casualty reporting on more-senior personnel. We did our best to validate our findings through various sources, and in some instances relied on best guesstimates to determine some data, such as the exact time or location that the casualty occurred. We are nevertheless confident the numbers recorded are a relatively accurate depiction of the circumstances surrounding the battle, providing ample detail for identifying critical trends that led to casualties in Fallujah.

Fallujah: Battle Narrative

Prelude: From the Fall of Baghdad to Fallujah I

The immediate context of the battle of Fallujah was the rapid decline in law and order set in motion by the U.S. invasion of Iraq (March to

³ LtGen. Richard Natonski speaks to this phenomena:

We had a Marine that was wounded early in the battle. He got shot in the leg. They medevaced him up to the railroad station. . . . They put him on the table and took his uniform off and were treating his leg. When they took his jacket off, they found he had a bullet wound in his arm. They asked when that happened. He said it happened a couple of days ago, but I wanted to stick with my buddies. After the battle was essentially over, we got 75 additional wounded reports. These were 75 Marines who after the battle reported their wounds. (Richard Natonski, interview, *The Army Archives*, April 3, 2008, pp. 16–17)

May 2003) and the U.S.-ordered dismantling of much of the Iraqi state and security apparatus. Unrest in certain parts of Iraq, among them Al Anbar Province, evolved into an insurgency that threatened Coalition forces, the Coalition Provisional Authority (CPA) (March 2003 to June 2004), and allied Iraqi groups.⁴ At the same time, the United States and the CPA struggled to keep Iraq on a political timetable that included returning power to Iraqis in the summer of 2004 (it took place on June 28) and holding elections in 2005. Also on the horizon were the November 2004 U.S. elections.⁵

Fallujah itself became a hotbed of anti-U.S. and anti-Coalition dissent in 2003, fueled in part by a series of incidents in April 2003 in which U.S. troops fired into crowds, killing civilians.⁶ U.S. forces all but abandoned the city to insurgents and conducted relatively few patrols over the course of the next year.

Insecurity in and around Fallujah increased steadily, until March 31, 2004, when four Blackwater contractors driving through Fallujah were ambushed, beaten, and set ablaze before being hanged from the trellis of a bridge crossing the Euphrates.⁷ Images of the lynching prompted the Bush administration to pressure Coalition forces to retaliate. On April 3, 2004, Combined Joint Task Force 7 commander Lieutenant General Ricardo S. Sanchez ordered the 1st Marine Expeditionary Force (IMEF) to attack the city. USMC commanders Major General James Mattis and Lieutenant General James Conway protested the order, arguing that retaliating would result in many civilian casualties, undermine their efforts to defeat the insurgency, and stymie serious attempts to find the specific people responsible for the

⁴ Lowry, 2010, p. xiv; Camp, 2009, p. 23.

⁵ Donald P. Wright and Timothy R. Reese, *On Point II: Transition to the New Campaign*, Fort Leavenworth, Kan.: Combat Studies Institute, 2008, p. 346; General George W. Casey, Jr., interview with Contemporary Operations Study Team, Fort Leavenworth, Kan.: Combat Studies Institute, February 5, 2008, p. 2; and interview with Colonel Lawrence D. Nicholson, Archives Iraqi OIF Study Group, January 18, 2005, p. 3.

⁶ Ian Fisher, "U.S. Troops Fire on Iraqi Protesters, Leaving 15 Dead," *New York Times*, April 29, 2003.

⁷ Public Broadcasting Service, "Private Warriors: Contractors: The High-Risk Contracting Business," *Frontline*, June 2015.

contractors. Conway later explained to the press that he thought it a bad idea to act precipitously out of emotion rather than let the situation settle and stick to the stabilization operations doctrine the Marines had prepared before their deployment.⁸ Nonetheless, I MEF attacked as commanded.

By all accounts, the assault on Fallujah, known as Operation Vigilant Resolve, had no real plan and only a few basic objectives, namely to arrest the perpetrators of the Blackwater attack, clear out foreign fighters, remove heavy weapons from the city, and clear Highway 10 for military traffic. There were, however, no shaping operations. The Marines simply cordoned off the city, and two battalions each on April 5 moved into the city center from the northwest and southeast, respectively. The USMC commanders reportedly regarded their forces as too small and asked for reinforcements. An Iraqi battalion was supposed to step forward but was attacked and withdrew. The USMC commanders struggled to make other units available to help with Fallujah operations, in part because they were tied down elsewhere. A third battalion arrived to join the fight on April 8, with a fourth arriving on April 24, and a USMC M1A1 tank company and USMC amphibious assault company were integrated into the fight.⁹ Figure 4.1 depicts the basic concept of operations (CONOP) for Fallujah showing the disposition of U.S. forces (and the defunct Iraqi battalion) as they initiated the plan of attack from four different directions.¹⁰

The Marines progressed slowly, fighting insurgents who operated amid the civilian population and used civilian structures, including

⁸ Chief Warrant Officer 4 Timothy S. McWilliams and Nicholas J. Schlosser, *U.S. Marines in Battle: Fallujah, November–December 2004*, Quantico, Va.: U.S. Marine Corps History Division, 2014, p. 2. See also Major Gerald de Lira, *The Anger of a Great Nation: Operation Vigilant Resolve*, Quantico, Va.: U.S. Marine Corps Command and Staff College, 2009, pp. 6–7; Rajiv Chandrasekaran, “Key General Criticizes April Attack in Fallujah: Abrupt Withdrawal Called Vacillation,” *Washington Post*, September 13, 2004.

⁹ de Lira, 2009, pp. 12–14; Matt M. Mattjews, ed., *Operation Al Fajr (Phantom Fury): Fallujah 2004*, Fort Leavenworth, Kan.: U.S. Army Combined Arms Center, 2015, p. 7.

¹⁰ In August 2015, the study team visited the U.S. Army Combined Arms Center at Fort Leavenworth and participated in a one-day “Battle of Fallujah” staff ride. All of the battle-field-related figures in this chapter were provided to us by the Center during that visit.

Figure 4.1
Operation Vigilant Resolve Concept of Operations



SOURCE: Google Earth image with overlay based on data from the U.S. Army Combined Arms Center.

RAND RR1602-4.1

homes and mosques. There were, naturally, a considerable number of civilian casualties, as well as damage done to Iraqi property, and the insurgents adroitly publicized an exaggerated account of the havoc the Marines were wreaking. Neither the Iraqi authorities nor U.S. officials at the time could stomach the bad press (the U.S. presidential election campaign was in full swing), and on April 9, the Coalition ordered the Marines to suspend operations in Fallujah, although fighting continued in fits and spurts until the Marines withdrew altogether on May 1. The toll was 36 U.S. military killed in action, 200 insurgents killed, and an estimated 600 Iraqi civilians dead.¹¹

¹¹ Jonathan F. Keiler, *Who Won the Battle of Fallujah?* Washington, D.C.: U.S. Naval Institute Press, January 2005; Fairness and Accuracy in Reporting, "CNN to Al Jazeera: Why Report Civilian Deaths?" April 15, 2004; de Lira, 2009, p. 19; McWilliams and Schlosser, 2014, p. 2.

The end of Vigilant Resolve did not, of course, bring security to Fallujah and the surrounding area, and the city became a magnet for insurgents of various stripes: former Baathists, Sunni nationalists, jobless army veterans, and indigenous and foreign Islamists. The Islamists had begun to coalesce around al Qaeda leader Abu Musab al-Zarqawi and represented a growing threat. USMC commanders, hoping to keep pressure on the city despite the imposed cessation of combat operations, gambled on the creation of the so-called Fallujah Brigade, to be led by a former Iraqi general, which would have responsibility for stabilizing the city while U.S. forces remained on the outskirts. The experiment failed. The Fallujah Brigade dissolved, and many of its members defected to the insurgent groups. The city, meanwhile, fell increasingly under the grip of the Islamists, who began to impose strict Islamic law and to conduct high-profile atrocities against Western hostages in their Fallujah safehouses. It was in Fallujah that Islamists beheaded – on video – American contractor Nicholas Berg, three British contractors, a Japanese contractor, and a South Korean missionary. Over the course of the summer, it became clear that the Marines would have to make another run against Fallujah.¹²

The Marines began planning and shaping the next offensive – which eventually came to be known as Phantom Fury or al Fajr – in July, well before its date had been fixed on any calendar. The initial steps included maintaining pressure on insurgents through raids and air strikes, collecting intelligence, isolating the city to prevent enemy escape and resupply routes,¹³ and building a surveillance network overhead with a growing fleet of drones and aerostats. The Marines stockpiled enormous quantities of ammunition, fuel, and other supplies.

¹² Thomas Ricks, *Fiasco: The American Military Adventure in Iraq*, New York, Penguin Books, 2006, p. 333; Matt M. Matthews, *Operation al Fajr: A Study in Army and Marine Corps Joint Operations*, Fort Leavenworth, Kan.: U.S. Army Combined Arms Center, 2015, pp. 9–10; Kendall D. Gott, ed., *Eyewitness to War: The U.S. Army in Operation AL FAJR: An Oral History*, Volumes I and II, Fort Leavenworth, Kan.: Combat Studies Institute Press, 2006; McWilliams and Schlosser, 2014, p. 4. Lowry, 2010, p. xiv; Camp, 2009, pp. 18–20; and Nicholson, 2005, pp. 1–3.

¹³ Interview with Colonel Michael D. Formica, Archives Iraqi OIF Study Group, December 13, 2004, pp. 2–6.

They also conducted an information operations campaign, requesting that Fallujah residents voluntarily evacuate from the city, and embedded more than 90 Western journalists.¹⁴

To preserve something of a tactical surprise, the Marines used raids and various deception measures intended to keep insurgents guessing as to when the attack would come and make them think the Marines would attack from the south, when the plans in fact called for an assault from the north. The raids helped identify enemy strong points and concentrations – which became bombing targets – and also encouraged large numbers of civilians to flee the city, minimizing their value as human shields. The USMC by the end of October believed that few civilians remained in the city, alongside 3,000–5,000 insurgents.¹⁵

Major General Richard Natonski believed it important to attack Fallujah with as much strength as possible. He requested – and received – reinforcements from the Army to the tune of two Army armored battalions and an Army armored brigade, in addition to a variety of other units, among them Iraqi battalions, that would provide various supporting roles and block the approaches to Fallujah. A majority of the combat Marines and combat soldiers of the Army mechanized battalions had previous combat experience in Iraq. A good portion of the Marines in the four infantry battalions had either taken part in the invasion of Iraq or had conducted counterinsurgency operations in Al Anbar Province in the year following. Both Army mechanized battalions had been in Iraq for nearly seven months prior to al Fajr. TF 2-7, for example, under Lieutenant Colonel Jim Rainey, had fought against Sadr militiamen in Najaf only a few months before in

¹⁴ *Les fantômes furieux de Falloujah: Opération al-Fajr/Phantom Fury*, Cahier du retex, Paris, Centre de Doctrine d'Emploi des Forces, Division Recherche et Retour d'Expérience, 2006, p. 49, 52–55. The initial title for the Second Battle of Fallujah was “Phantom Fury,” but after some discussion the decision was made to have the Iraqis give it an Arabic name, hence “al Fajr,” or “New Dawn” in English (McWilliams and Schlosser, 2014, p. 6; Camp, 2009, p. 163; interview with LTG (R) Thomas Metz, Commander MNCI, Archives Iraqi OIF Study Group, April 7, 2014, Part 2, pp. 4–7; interview with Colonel Lawrence D. Nicholson, Archives Iraqi OIF Study Group, January 18, 2005, pp. 3–4).

¹⁵ Lowry, 2010, pp. 59–60; Camp, 2009, pp. 141–145; McWilliams and Schlosser, 2014, p. 6; Keiler, 2005, p. 2; Kenneth W. Estes, *Into the Fray: Marines in the Global War on Terrorism*, Washington D.C.: U.S. Marine Corps Historical Division, 2011.

August. And Lieutenant Colonel Peter Newell's TF 2-2 had fought Sunni insurgents in the Muqadiyah area north of Baghdad for the previous seven months. But none of the U.S. Army and USMC battalions had participated in the kind of urban fighting in terms of the enemy confronted and the complexity and size of the overall operation that al Fajr would eventually present to them.¹⁶

The two Iraqi Army battalions assigned to Natonski's USMC division for the battle were probably better trained than any other Iraqi battalions at the time. However, the problem with the Iraqi Army battalions was not so much training but a lack of equipment: They rode in Toyota trucks and SUVs and with no night vision capability at all.

For Operation al Fajr, Natonski divided the city into roughly two halves and assigned to each half a regimental combat team (RCT), each reinforced by an Army armored battalion. He assigned the western half to RCT 1 and the eastern half to RCT 7 (see Table 4.1). He placed each to the north of the city, where they stacked up behind a massive earthen railroad berm. The Marines had copious air support resources placed at their disposal: fighter planes, attack helicopters, and the Air Force's AC-130H Spectre gunships.¹⁷

Figure 4.2 illustrates the distribution of forces before the initial assault. The RCTs would breach the berm at several points and then drive south and west while blocking forces sealed off the city's southern and eastern perimeters. RCT 1 would aim for Jolan Park and then move south and west into the so-called Pizza Slice (shown in Figure 4.3), while RCT 7 would gun for Phase Line (PL) Fran (also known as Highway 10 or MSR [main supply route] Michigan). PL Fran was the line dividing northern Fallujah from southern Fallujah. Once

¹⁶ Interview with LtGen. Richard Natonski, in "Operational Leadership Experiences," Combat Studies Institute, Fort Leavenworth, Kan., April 9, 2007, pp. 5-7; interview with LTC Jim Rainey, in "Operational Leadership Experiences," Combat Studies Institute, Fort Leavenworth, Kan., April 26, 2006, pp. 4-6; McWilliams and Schlosser, 2014, p. 5; Lowry, 2010, p. 69

¹⁷ Lowry, 2010, pp. 28-42; Camp, 2009, pp. 123-140.

the forces had made it to Fran, they would then continue sweeping south and west while clearing terrain behind them.¹⁸

Figure 4.4 provides a map of all of the PLs tactical commanders used to ensure units had a common picture of the battlefield.

Within the RCTs, the heavy Army task forces with their Abrams tanks and Bradley IFVs would apply shock and speed to smash as rapidly as possible into the center of the city, seize key objectives, and kill as many insurgents as possible, while Marines in dismounted units worked methodically in their wake, doing the dangerous and difficult task of clearing houses. Once the Marines caught up with the task forces, the Army would advance again and repeat the process.¹⁹

Figure 4.3
Fallujah Key Terrain

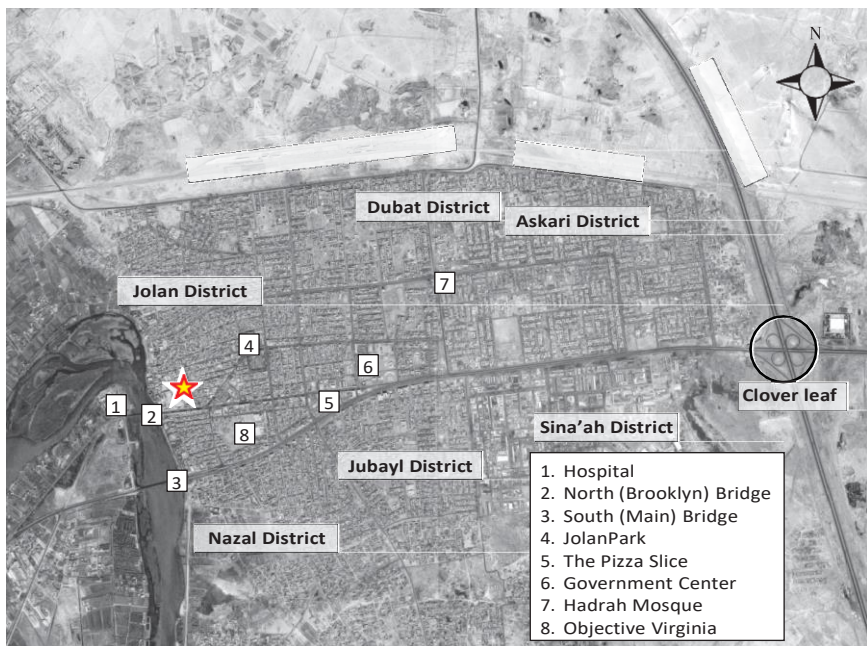

SOURCE: Google Earth image with overlay based on data from the U.S. Army Combined Arms Center.

RAND RR1602-4.3

¹⁸ Matthews, 2015, pp. 14–15.

¹⁹ Lowry, 2010, pp. 71–75.

Figure 4.4
Fallujah Map with Phase Lines Indicated

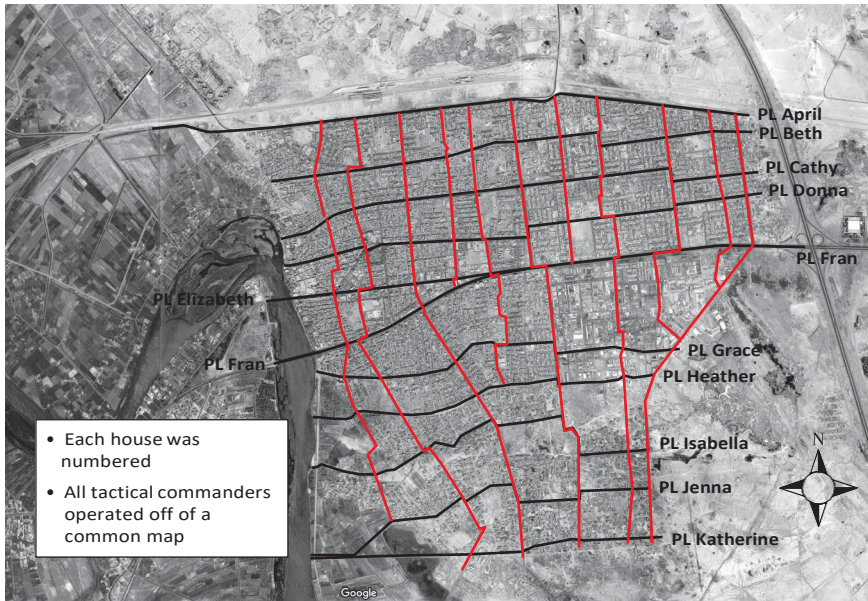

SOURCE: Google Earth image with overlay based on data from the U.S. Army Combined Arms Center.

RAND RR1602-4.4

The Second Battle of Fallujah **November 7**

On November 7, as the assault forces got into position, the joint forces made preliminary moves against a variety of targets. The most important moves consisted of a campaign of coordinated artillery and air strikes that began at 1900, while a force consisting of U.S. Army, USMC, and Iraqi units known as TF Wolfpack moved to seize the peninsula to the west of the city, including the two bridges into the city and a hospital at the tip of the peninsula (see Figure 4.3). By 0140 on November 8, TF Wolfpack had secured all of its objectives.²⁰

²⁰ McWilliams and Schlosser, 2014, p. 16; Lowry, 2010, p. 78.

November 8

The assault forces finished getting into position throughout the 8th, all the while exchanging fire with insurgents and conducting a variety of feints and reconnaissance missions. The main assault began that evening. First, Navy Seabees and Marines entered the electricity substation just west of the city and cut off its electrical power.²¹ At 1900, in the rain, the assault force advanced, with some providing cover while others focused on cutting breaches in the railroad berm.

Some elements had easier times clearing the berm than others, creating a degree of disorder in the opening hours of the campaign. In the western sector, the bulk of RCT-1 waited for hours in the rain while engineers attempted various means to blast through the berm and clear away the rails, all the while firing and being fired upon. TF 2-7 did not get through until 0130 on November 9, and even then the lane was too narrow to allow the force to move through as rapidly as planned. Once through, TF 2-7 rapidly smashed its way south down PL Henry into the Jolan District, while the Marines flowed into the city in the Army's wake and began clearing the district. To the east, in RCT 7's zone, TF 2-2 completed its breach by 1925 and advanced rapidly south to reach most of its objectives – namely Lion – within four hours. The 1/3 Marines, however, who were supposed to move in on TF 2-2's western flank, struggled for five hours to clear a breach before using the 2-2's breach. They did not reach Objectives Leopard and Coyote until late that night. The gap between the advancing Army units and the Marines continued, with the Army units moving faster than expected while the USMC units – who were in constant contact with the enemy – moved more slowly than expected.²²

On the second full day of the battle, the two Army task forces achieved their objectives. Figures 4.5–4.7 show the November 8–10 advance in Fallujah, during which TF 2-7 pushed south then west into

²¹ McWilliams and Schlosser, 2014, pp. 18–19; Karl Penhaul, Jane Arraf, Jamie McIntyre, Bessem Muhy, Cal Perry, Kevin Flower, and Mohammed Tawfeeq, "Battle for Falluja Under Way: U.S., Iraqi Troops Launch Offensive to Oust Insurgents," CNN, November 9, 2004.

²² Matthews, 2006, pp. 45–47, 60. See also Nathaniel Helms, *My Men Are My Heroes: The Brad Kasal Story*, Washington, D.C.: Naval Institute Press, 2007; Lowry, 2010, p. xiv; Camp, 2009, pp. 95–99.

Figure 4.5
RCT 1's Drive South (down on this map), November 8–9

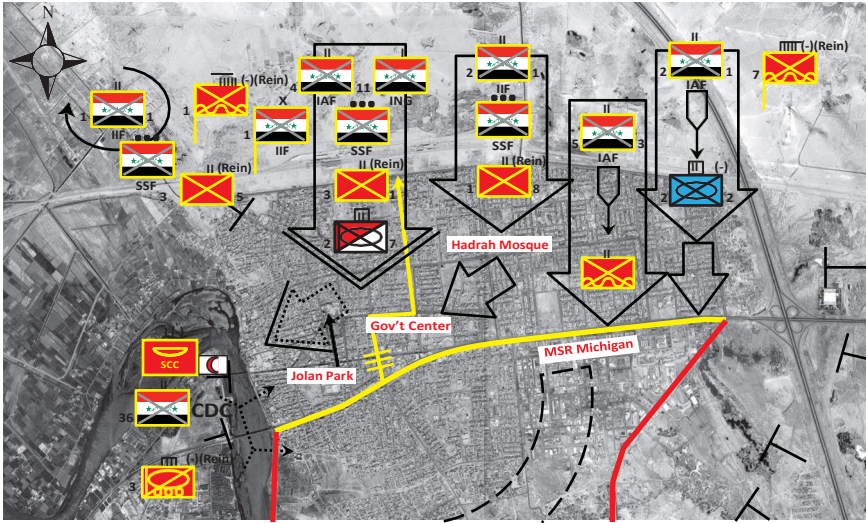

SOURCE: Google Earth image with overlay based on data from the U.S. Army Combined Arms Center.

RAND RR1602-4.5

Jolan Park reaching as far as PL Fran (MSR Michigan), where they were ordered to halt and wait for the Marines to catch up. Army units in fact had reached PL Fran within 14 hours of the beginning of the assault.²³ The Marines' progress, though much slower, was impressive. Among the objectives they reached was the al-Tawfiq mosque, which Marines seized in coordination with Iraqi troops; the Hadrah Mosque; and the Islamic Cultural Center.²⁴ In all three locations they found insurgent weapons and evidence that the insurgents were using the structures for a variety of purposes, such as treating the wounded and making IEDs.

²³ Matthews, 2006, p. 48; *Les fantômes furieux de Falloujah: Opération al-Fajr/Phantom Fury*, 2006, p. 59.

²⁴ McWilliams and Schlosser, 2014, p. 28. For a detailed discussion of this aspect of the advance, see Gott, 2006, Vol. I, pp. 122–124.

Figure 4.7
RCT 1's Drive South (up on this map) and West, November 9–10

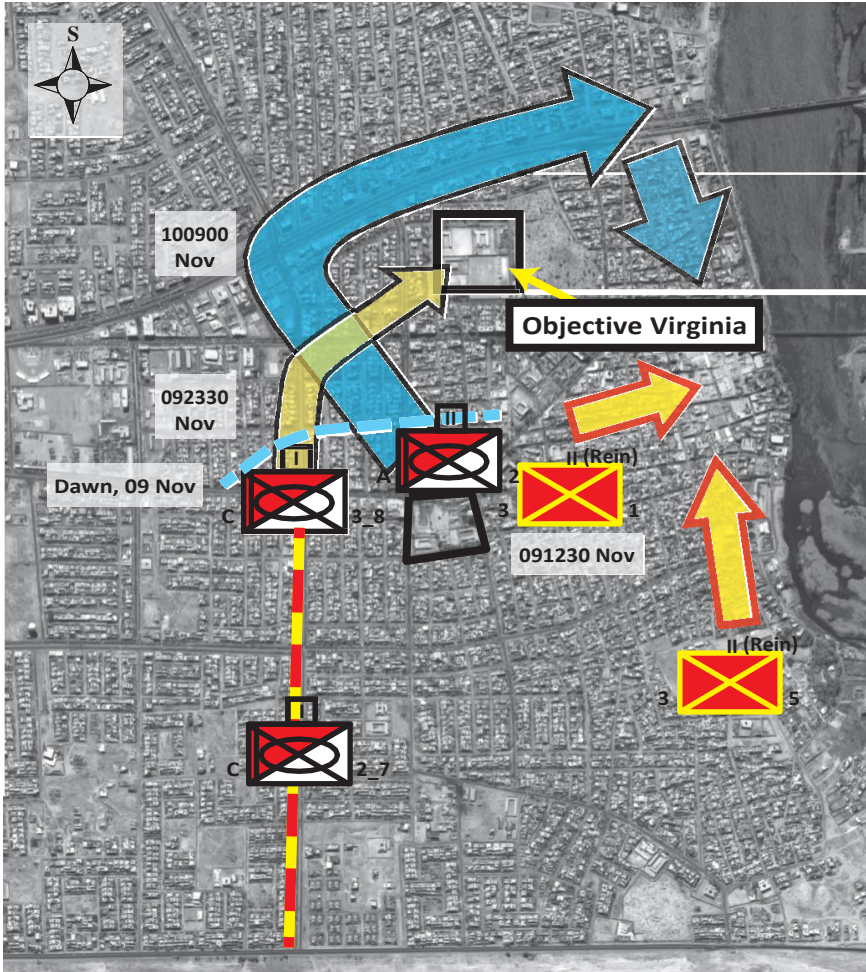

SOURCE: Google Earth image with overlay based on data from the U.S. Army Combined Arms Center.

RAND RR1602-4.7

updated the plan. He ordered a single USMC battalion from each of the RCTs to stay back and continue house clearing while the remainder of the RCTs, including the Army units, continued to move forward across PL Fran to attack southern Fallujah.²⁶

November 11

The third day of the campaign is generally regarded as the beginning of the battle's second phase. It was then that the assault forces crossed PL Fran and entered the city's southern districts, aiming for PLs Isabella and Jenna. RCT 1 moved south and west; RCT 7 more or less charged straight south. Below PL Fran, the soldiers and Marines encountered fierce resistance as well as better-prepared defenses, which reflected the insurgents' assumption that the attack would come from the south. The rest of Fallujah was by no means pacified, however, as soldiers and Marines in nearly every sector had to clear and reclear houses, deal with ambushes, and cope with IEDs, indirect fire, and snipers. For example, when the Iraqi interim health minister and other dignitaries flew in by helicopter to visit the hospital, which had been one of the first objectives taken by TF Wolfpack on November 8, insurgents attacked the hospital with indirect fire. Indeed, TF Wolfpack fought a series of actions that day to defend itself while securing lines of communication. By the end of the day, many of the Army units in TF 2-7 had reached the southern limits of the city; TF 2-2 had to halt at around 2000 to wait for the Marines to fight their way to them; TF 2-2 resumed its drive at 2300, and soldiers and Marines fought through the night.²⁷

November 12

The next day brought more intense fighting. Many of the Army heavy units pushed on to PL Jenna, while elements of TF 2-2 entered the industrial zone.²⁸ Marines fought to clear new districts, such as Nazal and Queens. Again, those to the rear of the advancing line had to fight insurgents who had slipped back in or perhaps had simply gone to

²⁶ Estes, 2011; McWilliams and Schlosser, 2014, p. 39; and Natonski, 2008, pp. 15–16.

²⁷ Camp, 2009, pp. 233–247.

²⁸ *Les fantômes furieux de Falloujah: Opération al-Fajr/Phantom Fury*, 2006, p. 64.

ground and waited. USMC companies fought running battles along Highway 10 and PL Isaac, which were lined with IEDs; RPG teams swarmed Bradleys, scoring several successes.²⁹

Still, the soldiers and Marines pushed on; TF 2-2, for example, got 1,000 meters beyond PL Isabelle before standing down for the night, while Marines from the 1st Battalion, 8th Marines (1/8 Marines), attacked through the night to catch up, reaching Isabelle by 2300. During the assault, the Marines found buildings rigged to explode and a tunnel network, in which they found documents on insurgent bodies and in caches that identified many as coming from a wide variety of countries. By the end of the day, RCTs 1 and 7 had reached Fallujah's southern limits, and the assault forces had reached all of their objectives. In northeast Fallujah, RCT-7 also began providing humanitarian aid to some of the few remaining civilians, and a civil affairs team moved into the recently cleared government center, where it established a civil-military operations center.³⁰

November 13–14

Reaching an objective is not the same thing as securing it, and on November 13, Natonski and his staff divided the city into sectors and directed the soldiers and Marines under their command to focus on systematically clearing it of insurgents and weapons. In southwest Fallujah, RCT-1 Marines began clearing their sectors while TF 2-7 held PL Henry in support. Resistance at this point was particularly fierce. Enemy combatants who stood and fought understood they would die and were determined to kill as many Americans as they could before succumbing. Their ferocity also often reflected both the use of drugs on the part of the insurgents, which gave them nearly superhuman strength and endurance, and their relative professionalism. In other words, some of the worst house fighting of the battle came in these final stages, including the fight that day at the so-called "House of Hell." It was given this name because 3rd Battalion, 1st Marines (3/1 Marines),

²⁹ McWilliams and Schlosser, 2014, p. 46–47; For examples of unit-level detail of the fight at this point, see Lowry, 2010, pp. 174–188.

³⁰ McWilliams and Schlosser, 2014, p. 48.

confronted highly sophisticated, well-trained, fanatical Chechen fighters in a well-defended building. TF 2-7 commanders toward the end of the day approached USMC leaders with a proposal to support USMC clearing operations more directly, and soon elements of TF 2-7 began operating in tandem with 3/1 Marines. Using elements of TF 2-7 would also assist in reconnaissance operations, since their tanks and Bradleys could probe and scout out enemy positions with their protection and immediately available firepower.³¹ To the east, TF 2-2 pushed south and west, while the Marines at its flanks cleared buildings; both encountered resistance similar to what RCT-1 was finding.

The intensification of the house fighting correlates with a shift in tactics that different units appear to have adopted at varying times, on their own initiative (we analyze this shift in more detail below). Namely, rather than clear houses with insurgents by fighting room to room – which led to numerous casualties – Marines and soldiers would back out of houses once they had made contact and avail themselves of whatever means were at their disposal to level them.³²

The next day featured more of the same: house-by-house clearing and reclearing operations in nearly all of Fallujah's sectors, with frequent combat. Nonetheless, humanitarian and reconstruction operations began wherever possible, often in close proximity to fighting. RCT 7's humanitarian center at the al Hadrah Mosque became increasingly busy as civilians found their way to it. In Jolan District, Marines arranged for Iraqis from a nearby town to enter the city with trucks and recover dead insurgents.³³

November 15

Relative quiet marked the 15th, notwithstanding recurrent artillery and air strikes and small arms fire. Army and USMC units increasingly rotated in and out of battle, resting up quickly before returning to the clearing operations. They continued to find weapons caches,

³¹ Helms, 2007; O'Donnell, 2006; Livingston, 2005.

³² Lowry, 2010, pp. 206–207.

³³ Estes, 2011; McWilliams and Schlosser, 2014, pp. 53–55.

meet resistance, and take casualties, although less frequently than in previous days.

November 16–17

The focus began to shift to humanitarian and reconstruction efforts, as many of the units shifted to stability operations.³⁴ The insurgents, though still capable of inflicting casualties and engaging American forces, clearly were on their last legs. Elements of TF 2-2, for example, moved south on the 16th and began clearing the west side of the industrial district, where they encountered pockets of fighters. Recalled one Army officer:

We received the order to move south, as we started rolling through this maze of warehouses and machinery, junk piles and scrap heaps, we cleared virtually every inch with fires, both direct fires and indirect fires walking out in front of our move. We knocked open every door, knocked down every wall, and if the road stopped in front of us, we just made a new one, driving our tanks right over sheds and making new paths through concrete buildings. There was no place for anyone to hide, the enemy thought we would use the roads and he would be able to hide among the small buildings. Again, the shock effect of seeing a M1 A1 tank driving through your hiding place sent fear streaming through those who stayed to fight.³⁵

Marines following behind the armored forces noted similarly that,

After that, the only guys we ran across were the ones that weren't smart enough to get out or couldn't. There was very little left after that point, but we still went building-to-building and room-to-room and went through everyone one of them. At that point, we started clearing the caches.³⁶

³⁴ Camp, 2009, p. 282.

³⁵ Avenger Company, 2nd Battalion, 63rd Armored Regiment, "Narrative of Combat Actions in Fallujah from 4 to 23 November 2004," Memorandum for Record, November 25, 2004, provided to RAND by Matt Matthews, June 4, 2015.

³⁶ Gott, 2006, Vol. I, p. 105.

November 18–19

Clearing operations continued, resulting in occasional firefights with remaining insurgents, who were able to initiate direct and indirect fire attacks. Nonetheless, Army and USMC commanders were able to rotate more and more units out of the fight to rest, and reconstruction efforts picked up steam.³⁷

November 20–24

TF 2-7 and TF 2-2 withdrew from the city, while RCT-1 prepared to assume sole control over Fallujah. From this point on, the focus was entirely on reconstruction and managing the resettlement of returning civilians. The fighting was by no means over, as Marines continued to encounter insurgents through the month of December.³⁸ Only on December 23 did American and Iraqi senior military and political leaders deem the city sufficiently clear of insurgents to open it to resettlement.³⁹

Battle Conclusion

The Second Battle of Fallujah never came to a conclusive ending, but instead transitioned into a stability operation before Americans finally left the area for good several years later. All in all, the battle can be regarded as a success, although its overall contribution to the Iraq war is debatable. The price was certainly high: The study team documented 412 casualties in Fallujah from October 17 to December 23. Of that number, 82 Marines, seven U.S. Army soldiers, and one U.S. Navy hospital corpsman never made it home.⁴⁰ Understanding more pre-

³⁷ McWilliams and Schlosser, 2014, p. 59.

³⁸ Natonski, 2008, p. 16.

³⁹ McWilliams and Schlosser, 2014, p. 64.

⁴⁰ Estimates for the number of U.S. casualties vary depending on the source. For example, historians from the History Division at Quantico reported 82 killed in action (KIA) and more than 600 wounded in action (WIA) (McWilliams and Schlosser, 2014, p. 66); another historian's account reported 63 KIA, 535 WIA, (Camp, 2009, p. 299). The Manpower Department, Marine Corps Headquarters, documented 70 Marines KIA, 651 WIA (Estes, 2011, p. 78); Another by the French Ministry of Defense recorded 72 KIA and 632 WIA (*Les fantômes furieux de Falloujah: Opération al-Fajr/Phantom Fury*, 2006, p. 64). We

cisely when, where, and how these casualties occurred in Fallujah may shed light on some of the challenges U.S. combat forces will likely find themselves in urban settings in the future.

Fallujah II: Analytical Trends-Based Casualty Data

Figure 4.8 shows the approximate time of day that military casualties occurred during Fallujah II. The blue area of the chart represents hours of darkness, and the yellow areas hours of daylight. The data indicate that the preponderance of casualties occurred during the morning and afternoon hours of mid-November.

Figure 4.9 illustrates the number of casualties over time and indicates a significant spike around the 13th and 14th of the month.

This timing of casualties corresponds with two consistent combat action trends in Fallujah. First, the Marines' preferred method of fighting was during daytime hours, reserving nighttime operations for air-power and artillery strikes to "soften" enemy positions in preparation for the ground fight Marines would engage in each morning. Second, the uptick in casualties approximately three days into the battle occurred as combat forces pushed south and began coming into contact with far more sophisticated fighters than they had faced in the first few days of the battle. As 2-2 commander Lieutenant Colonel Peter Newell recalled, "Up north, it was the remnants of the Fallujah Brigade, and in the south it was clearly nothing but foreign fighters. In fact, we learned later that the foreign fighters had chased out all the native Iraqis in that district months ahead of time."⁴¹

list these to demonstrate how these estimates vary, although they are all fairly close. The variance often has to do with how casualties were counted: Some compiled casualties from all services, while others focused on USMC counts. There are also temporal dimensions that a source determines for the casualty figures. For example, if one only uses the dates November 7 to November 24 for the battle itself, rather than a more expansive period, say, from October 30 to December 24, then obviously the figures would be lower.

⁴¹ Interview with LTC Peter A. Newell, in "Operational Leadership Experiences," Combat Studies Institute, Fort Leavenworth, Kan., March 26, 2006, p. 14.

Figure 4.8
Casualties at Approximate Time of Day in Fallujah II

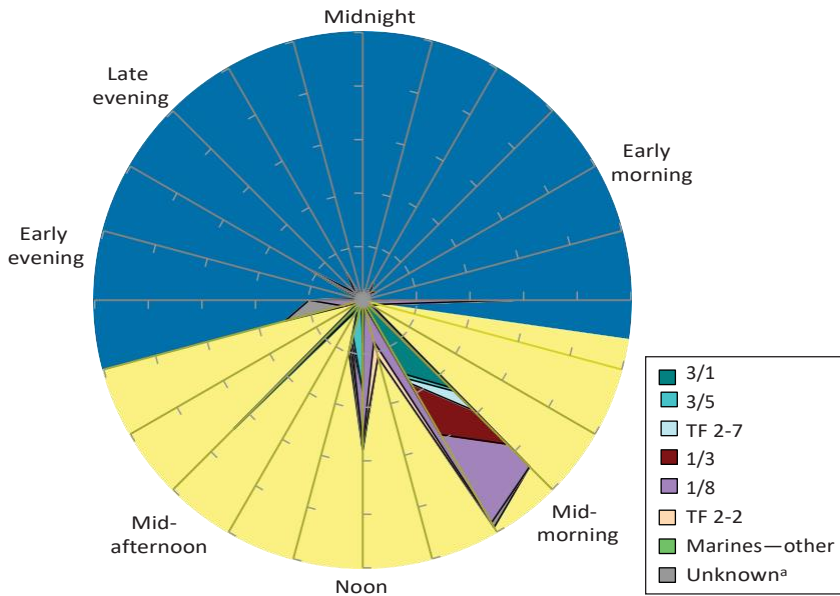

NOTE: This chart represents only those casualties where sources provide a time of day. It does not represent the cumulative number of casualties by unit.

^a Sources provide time of day but not a specific unit.

RAND RR1602-4.8

These insurgents appeared to be more fanatical, better equipped, and better trained. Many of them were Chechens or other foreign fighters. They made good use of holes in walls and floors and shallow tunnels to evade pursuing Americans, only to reemerge to attack them somewhere else. These insurgents also proved adept at staging ambush kill zones within courtyards and inside buildings and understood well that they could inflict many more follow-on casualties as Marines rushed into houses to retrieve their wounded.⁴²

The enemy that the First Marine Division faced in Fallujah was still not a first-order force, lacking armored capabilities, electronic warfare, air defense, fires, C2, etc. Such an enemy would have certainly

⁴² Helms, 2007; O'Donnell, 2006, pp. 127–128, 146.

Figure 4.9
Fallujah II Casualties over Time

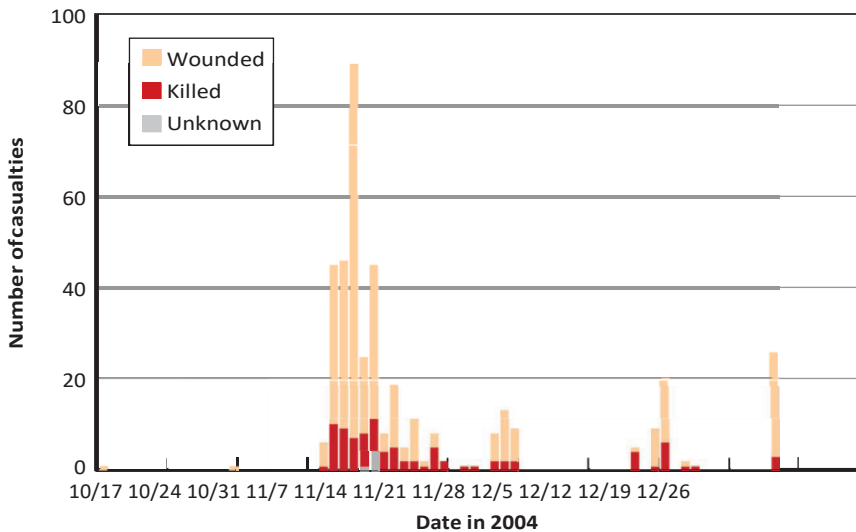

RAND RR1602-4.9

called for a very different approach than the one First Marine Division actually used. Still, the actual enemy in Fallujah did present some tough tactical problems. A good portion of the enemy forces were competent in individual light infantry fighting techniques and the use of small arms, light mortars, and RPGs. Collectively, they could come together in small groups to fight effectively using limited C2. And, significantly, the will and determination of many of these fighters reached the point of fanaticism.⁴³ Combine these attributes with the fact that the insurgents knew the terrain of the city and its structure and used that knowledge to build effective individual building defenses and ambush points outside of them on the streets, and one finds a formidable enemy force.

⁴³ Interview with Captain Natalie Friel, July 28, 2006, in Gott, 2006, Vol. II; interview with Colonel Michael Shupp, March 25, 2006, in Gott, 2006, Vol. I; interview with Major Andy Dietz, February 26, 2006, in Gott, Vol. I, 2006. For a useful taxonomy that categorizes potential enemy forces in the present and future, see Johnson, 2011.

Figure 4.10
Officer and Enlisted Casualties in Fallujah II

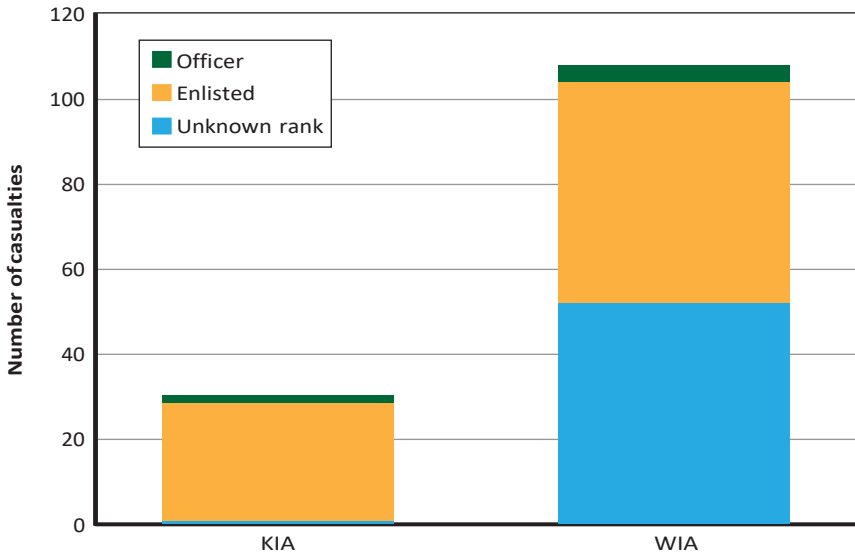

RAND RR16024.10

As Figure 4.10 suggests, enlisted personnel were on the receiving end of enemy attacks and, assuming the ratios are similarly represented in the missing data, were ultimately the ranks that suffered the most casualties. This corresponds with the manpower-intensive nature of infantry-centric combat and the fact that enlisted ranks made up the majority of the fighting force in Fallujah II. Referring to a picture of one lance corporal celebrated on the front cover of the *New York Post*, Major General Natonski acknowledged, “It was guys like that right there that made it a success, and a lot of other soldiers, sailors, Marines, and airmen. It wasn’t the generals and colonels that were kicking in the doors, it was the lance corporals and specialists.”⁴⁴

Most casualties occurred when dismounted Marines were either patrolling the narrow streets and alleyways of Fallujah or engaged in

⁴⁴ Natonski, 2008, p. 67.

house-to-house clearing operations (Figure 4.11), which reflect the infantry-centric nature of fighting in Fallujah II.

The data in Figure 4.12 suggest that far fewer casualties occurred in units equipped with mechanized vehicles.

When units from RCT 1 and RCT 7 began to perceive these patterns, USMC rifle battalions began to adapt. The adaptation was essentially this: For the first three to four days of fighting (November 9–13), the basic tactical method for USMC infantry battalions for clearing buildings of enemy fighters was to rely primarily on dismounted infantry supported whenever possible by USMC tanks and indirect firepower; however, after certain USMC battalions using this method took heavy casualties, an adaptation was made to rely less on dismounted infantry to clear buildings heavily defended by enemy fighters and more on armor and firepower. This adaptation made an important difference, because it enabled these units to complete their mission of clearing Fallujah of insurgent fighters, but at a significantly lower USMC casualty rate.⁴⁵

Figure 4.11
Fallujah II Casualties, by Situation Type

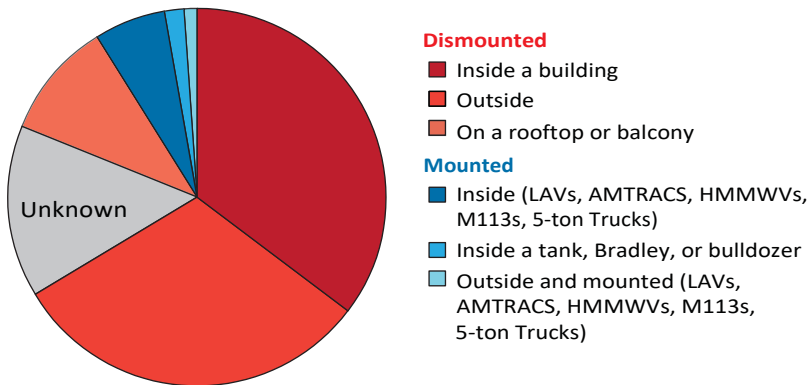

RAND RR1602-4.11

⁴⁵ Virtually all of the secondary accounts note this shift in USMC tactics on or about the third day of the battle. However, the rationale for the shift is often left unexplored by these sources. There are also a number of interviews of Marines in the rifle battalions in Fallujah two that also attest to this shift. These secondary and primary sources are discussed in more detail in the following sections.

Figure 4.12
Fallujah II Casualties, by Absence or Presence of Vehicle Type

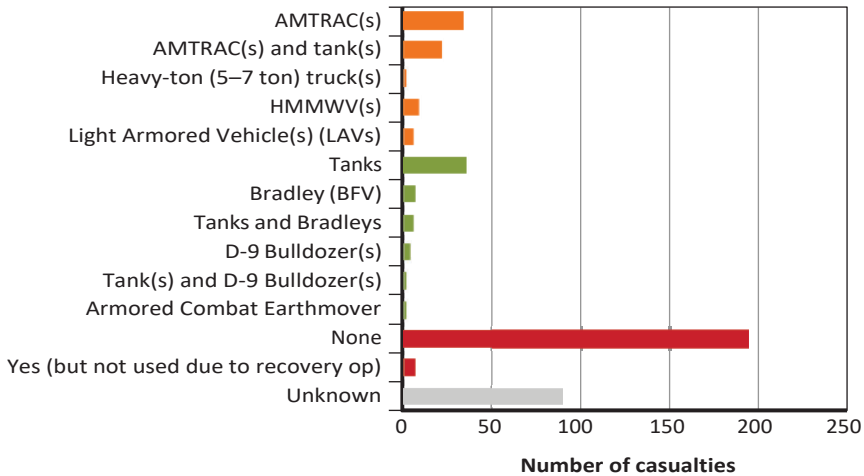

RAND RR1602-4.12

Oftentimes, a simplistic approach to military history attributes these kinds of adaptations simply to common sense. However, the more serious students of military history understand the difficulties of successful adaptation in war and the fact that such adaptations are never a foregone conclusion. They therefore understand the utility in explaining the details and nuance of these adaptations so that insights can be gained. Thus, the following sections provide unit-specific examples of the type of adaptation that occurred during Fallujah II and how these imaginative tactical shifts enabled U.S. forces to shrink the problems presented by urban combat to great effect.⁴⁶

⁴⁶ For an excellent survey of how various military forces have adapted in war, see Harold R. Winton and David Mets, *The Challenge of Change: Military Institutions and New Realities, 1918–1941*, Lincoln, Neb.: University of Nebraska Press, 2003. For a more specific case study of tactical adaptation in Iraq, see James Russell, *Innovation, Transformation, and War: Counterinsurgency Operations in Anbar and Ninewa Provinces, Iraq, 2005–2007*, Stanford, Calif.: Stanford University Press, 2011.

Adaptation and Imaginative Thinking in Fallujah II

Combat in urban areas is primarily a small unit, infantry-intensive operation.

– Marine Corps Warfighting Publication 3-35.3, *Military Operations on Urban Terrain (MOUT)*, 1998

It's a man-on-man fight, a classic infantry battle... If you've got a guy sitting in a house with two grenades, who knows he is going to die, we're going to root these guys out, house by house.

– Colonel Craig Tucker, Commander Regimental Combat Team-7, USMC, November 2004

Keep hammering targets and if you see a guy with an AK-47, I expect you to hose him with a .50 caliber machine gun. If firing was identified from a house, then artillery fire should be called in to pancake the building because there is not a building in this city worth one of our soldiers' lives.

– Lieutenant Colonel Peter Newell, Commander TF 2-2, U.S. Army, November 2004

... and it was probably the biggest thing that we learned was that, them, you just can't really compete with people that are fortified into a house and you got to find some other means, if you can, to minimize the threat and take it out. So, that really changed our TTPs [tactics, techniques, and procedures] within our squad and our platoon, as far as assaulting houses. When we took contact, we were now just gonna pull back from the house and hit it with a rocket or dozer. So, we didn't want to see any more of our Marine brothers get shot or wounded.

– Lance Corporal Justin A. Boswood, Fire Team Leader, Kilo Company, 3/1 Marines, October 2005

The set of quotations that we used to lead off this section actually provide the basic contours of USMC rifle battalion adaptation in Fallujah II. The first quotation, from the 1998 USMC doctrinal manual *Military Operations on Urban Terrain (MOUT)*, states that combat operations in urban terrain is an “infantry-intensive” proposition.⁴⁷ The Army field manual from the same timeframe agrees about urban combat operations being infantry-centric.⁴⁸ In the second quotation, Colonel Craig Tucker, commander of RCT 7 in the battle of Fallujah II, channeled this infantry-centric mentality when he told the RCT in the days prior to the start of the battle that it was a “man on man fight, a classic infantry battle.”

However, the third quotation in the set, by the commander of TF 2-2 Infantry, Lieutenant Colonel Peter Newell, makes an important departure from doctrine. Newell, in a talk with his battalion just prior to the battle, planned on adopting a different mindset on how to go about conducting combat operations in urban terrain and told his task force shortly before the fight to rely primarily on firepower to destroy insurgent fighters in the building.⁴⁹ Once the battle began, Newell’s mechanized battalion task force applied this approach in action against the enemy in Fallujah. The scout platoon sergeant for TF 2-2, Sergeant First Class Daniel Bumbaugh, provides a clear description on how his platoon (outfitted with up-armored Humvees but no organic tanks or Bradleys) relied on firepower and not primarily muscle power to clear buildings of enemy fighters:

When the dismounts tried to enter and clear house number 4, they encountered stiff resistance from insurgents armed with rockets and RPKs, we set up security around the base of the house as best we could [firing] countless .50 cal and MK-19 rounds at the building and we still could not gain a foothold into the house. Every time we tried an insurgent would either fire a rocket down

⁴⁷ Marine Corps Warfighting Publication 3-35.3, *Military Operations in Urban Terrain (MOUT)*, Washington, D.C.: Headquarters U.S. Marine Corps, April 26, 1998.

⁴⁸ FM 3-06, Chapter 1.

⁴⁹ Quoted in Matthews, 2006, p. 40.

the steps from the 2nd floor or throw grenades down at our dismounts. The [lieutenant] called the [company commander] and had a Bradley come in and suppress with 25mm. It was still no good. We called up a D-9 bulldozer and removed part of the ground floor and still nothing. It wasn't until we brought in an M-1 [tank] that we were finally able to enter the house.⁵⁰

The fourth quote from the above set, from Lance Corporal Justin A. Boswood, shows that that the initial USMC method of clearing heavily defended buildings by relying primarily on dismounted infantry was causing too many casualties, and therefore the Marines began to shift to other methods available. Adaptation in tactical method therefore occurred around three days into the battle, when stiff enemy resistance caused USMC infantry battalions to adjust their tactical methods along the lines Lance Corporal Boswood recalled.⁵¹

Some secondary accounts, however, contend that the rules of engagement (ROE) that USMC rifle battalions in Fallujah II started the attack contained numerous restrictions on the use of firepower to reduce the level of physical destructiveness to Fallujah. This so-called restrictive ROE was forced on the USMC infantry battalion by American political leadership, who were worried about turning Fallujah into rubble for all the world to see. According to journalist Patrick K. O'Donnell, who was embedded with an infantry platoon from 1/8 Marines, the cause for the shift in Marines' tactical method that allowed them to use increased amounts of firepower when they went up against stout enemy defenses in buildings had to do with a loosening of these restrictions. O'Donnell argued that

Using the Bangalore [a tubular mine used for breaching obstacles] marked a turning point in the platoon's tactics. Initially, high level fears about civilian casualties forced the Marines to clear houses by hand, employing machine guns and hand grenades. With the Bangalore, the engineers and assault-men gave

⁵⁰ Daniel Bumbaugh, "Fallujah Study," email to Matt Matthews, February 20, 2006.

⁵¹ Lance Corporal Justin Boswood, USMC Field Historian, interview, October 21, 2005, provided to RAND by Matt Matthews.

[Marines] the option of blasting a building rather than risking Marine lives to clear it.⁵²

According to this line of reasoning, it was only after Marines took heavy casualties during the first three to four days of the fighting that the ROE was adjusted and gave Marines much more liberal use of firepower to destroy buildings with enemy fighters inside, thereby reducing the overall number of casualties.

To be sure, restrictions were placed on U.S. combat units in Fallujah to protect certain buildings, such as mosques, from destruction. USMC information operations officer LtCol. Stephen McCarthy noted that

The main points [of the upcoming Fallujah battle] were twofold: (1) dominate the information getting out, and (2) minimize the casualties. Some of that was forced from above. The term that we got from Baghdad was the *IO Threshold*. There was a belief in Baghdad that we could do things up to a point, and if you hit below that threshold, we could keep doing it, and it wouldn't cause a media uproar. So that drove a lot of our actions.⁵³

However, nothing in the primary sources of interviews of USMC participants in the battle and in the rifle battalion command chronologies suggests the shift in tactics that occurred had anything to do with a loosening of the ROE to allow greater applications of firepower as Marines and Soldiers confronted the enemy on the streets and in buildings in Fallujah.⁵⁴ Indeed, RCT 7's "Command Chronology" (a detailed description by the regimental staff of the day by day activities

⁵² O'Donnell, 2006, p. 107; also see Camp, 2009, p. 152; Natonski, 2008, p. 28.

⁵³ Natonski, 2008, p. 28.

⁵⁴ Command Chronology for Regimental Combat Team 7, July–December 2004, provided to RAND by Matt Matthews, June 18, 2015; Command Chronology for 1/3 Marines, July–December 2004, provided to RAND by Matt Matthews, June 18, 2015; and Command Chronology for 3rd LAR Battalion, October–November 2004, provided to RAND by Matt Matthews, June 6, 2015.

of the regiment during the battle) highlighted the fact that only two days into the battle

... over 30 air strikes had been conducted in RCT-7's zone, many of them controlled by the RCT Air Section. One of the more notable missions was removal of the minarets used as sniping platforms with little to no damage to the mosques. In total, 8 minarets were eliminated while only 1 mosque was damaged by aviation ordinance.⁵⁵

Instead, Marine innovation and adaptation at the tactical level brought about this change. Individual units did not always proceed in this fashion, however. Some units shifted course toward using more firepower, though that decision was subject to availability of mechanized assets and often became a priority only after a unit began taking heavy casualties. A detailed account of how individual units came to make this tactical adaptation – and when they did not – will help to bring into sharp relief where and why that adaptation finally occurred when it did.

USMC Tactical Adaption in Fallujah II

As mentioned, for the first four days of fighting in western Fallujah, Lima Company 3/1 Marines generally relied on USMC fire teams and squads to clear enemy fighters from buildings. These fire teams and squads would use tanks whenever they could get them, although there were only ten M1A1 tanks in total assigned to RCT 7, so the availability of tanks to rifle platoons and below was spotty at best.⁵⁶ USMC infantry would also rely heavily on additional firepower provided by a rifle company's weapons platoon and a battalion's weapons company. Still, for these first four days, the basic method for clearing homes for 3/1 Marines of enemy fighters was to pile infantry teams into the buildings and use whatever additional firepower they could acquire to support.

⁵⁵ Command Chronology for Regimental Combat Team 7, 2004.

⁵⁶ Interview with Colonel Michael Shupp, March 25, 2006, in Gott, 2006, Vol. I, p. 42; Livingston, 2005.

For example, one of the squad leaders from First Platoon of Lima 3/1 Marines, Sergeant Bennie Connor, confronted an insurgent fighter armed with a PK7 machine gun in a building in northwest Fallujah on 9 November. Connor was the first Marine into the building and came face to face with an enemy machine gun. Fortunately, the gun misfired, and Connor “rolled out of the way.” However, as he noted, “everything was already in motion. My Marines, being Marines, make entry into the room.” The first Marine into the building behind Connor was shot in the neck and killed, then, just a few minutes later, another Marine moving into the building was also killed by enemy fire. Connor reported to his platoon commander Lieutenant Sommers that inside the building “we have a bunker, and are having a problem with it. . . . We’ve got a man down . . . I have two Marines killed in action. . . . These guys [enemy fighters] are really stubborn, I can’t get to them.” Connor’s Lieutenant then ordered him to get clear of the building along with his remaining Marines and to put a “rocket on it.” An assault weapons team did just that, and added another rocket, which flattened the building and the insurgent fighters inside. After this engagement, company Gunnery Sergeant Matthew Hackett noted that the enemy’s “discipline throughout the battle” amazed him. “They just sat in the house and waited . . . for the perfect shot, our faces and necks, since our body armor and [helmets] protected our bodies. Their goal was to kill an American and die.”⁵⁷

After another especially bloody day on November 12, Sergeant Connor and Gunnery Sergeant Hackett reflected on the loss that First Platoon had suffered – nearly half of the platoon killed or wounded – and the fact that Connor’s third squad was down to three Marines, including himself, from the original 13 he entered Fallujah with on November 9. Connor lamented that, “everywhere we go, we run into stuff . . . other platoons aren’t running into shit. What are we doing wrong? We are doing what we are supposed to be doing, but we are just getting [hammered].” Tellingly, Gunnery Sergeant Hackett responded to Connor that “we are not entering houses anymore without prepping

⁵⁷ O’Donnell, 2006, pp. 85–88.

with grenades or rockets, minimum a grenade.”⁵⁸ First Platoon shifted from muscle power to firepower because the initial approach had led to an unacceptable number of casualties. Other USMC rifle outfits in Fallujah made similar shifts around the same time, though the change seemed to occur independently, unit by unit. 1st Marine Division Commander Major General Richard Natonski noted in a post-battle interview this shift as well. He noted that at first the Marines in the rifle battalions would move into buildings to take out defenders. However, as the battle “progressed,”

because of the intensity of the resistance and if we knew there were insurgents in buildings, in some cases we’d drop the structure before we’d risk soldier or Marine lives by sending them into buildings. We used everything from tanks at close range shooting up the buildings to D9 armored bulldozers to 500-pound JDAMs [Joint Direct Attack Munitions].⁵⁹

Staff Sergeant David Bellavia, an infantry squad leader in TF 2-2, sheds light on how another unit’s tactics had shifted rather early on in the battle. Shortly after the breach of the railroad tracks on the evening of November 8, Bellavia and his squad found themselves moving dismounted through the streets of northeast Fallujah. After a very close call, nearly entering into a home laced with IEDs and grenades, Bellavia was relieved when his company commander, Captain Sean Simms, told him that there would be a “change of plans” and that his company would no longer walk “separate from the” tanks and Bradleys. “We’ll keep our support by fire base,” noted Simms. Both Bellavia and Fitts agreed with Simms that it meant that the platoon “won’t be kicking in any more doors without the Brads and tanks backing us up.”⁶⁰

A similar shift can also be seen in RCT 7’s eastern section with 1/8 Marines commanded by LtCol Jarret Brandl. 1/8 Marines had been tasked to move through 1/3 Marines and TF 2-2 shortly after the

⁵⁸ O’Donnell, 2006, p. 141.

⁵⁹ O’Donnell, 2006.

⁶⁰ David Bellavia, *House to House: An Epic Memoir of War*, Pocket Star Edition, 2008.

breach on November 9 and attack south to secure what was called the "Government Center," just south of PL Fran. For approximately three days, Marines of 1/8, with some tank support, predominantly cleared buildings with infantry squads during the day, then hunkered down in defensive positions in buildings during the night. However, and as was the case with 3/1 (described above), the Marines using this tactical method took heavy casualties. One Navy medical corpsman attached to 1/8 remembered seeing "seven [Marine] KIAs" come "through our aid station" on November 13.⁶¹ Battalion commander Brandl reflected on how he and his battalion adapted tactically after their intense light infantry fighting around the government center. Brandl noted that

When we lost Marines we asked ourselves, is there something we're doing wrong? If so, we need to change our tactics right now. We did do some evolution of tactics when we punched farther south. We used the engineers and bulldozers to isolate the houses that held the enemy. In place of sending Marines in, we would bulldoze the house down with the D-9s.⁶²

In another example, not until after the costly engagement on November 13 in the "Hell House" did Lance Corporal Justin Boswood, a team leader in 3/1, note that it was just too costly to try to clear a building defended stoutly by competent enemy fighters. Instead, Boswood noted that they adapted at that point to a new method that had them breaking immediate contact from a building if it was heavily defended, "pulling back" and then using tanks, bulldozers, or other heavy weapons and firepower to destroy the enemy in the building without relying primarily on infantry muscle power to do it.⁶³

Despite the fact that Marines had to learn the hard way before shifting tactics, the need for adaptation ultimately became clear for each unit: Do not lead into buildings heavily defended with light infantry supported only by small arms and some heavier weapons; instead,

⁶¹ Livingston, 2005.

⁶² Quoted in Livingston, 2005.

⁶³ Boswood, 2005; Helms, 2007.

lead with heavy firepower and armored vehicles to destroy or reduce the enemy fighter threat to the point that light infantry can clear without heavy losses.

Marines also experimented with the tactical posture of its infantry and mechanized forces. As Natonski describes,

It was interesting because we started with tanks and the infantry followed. We tried in some cases things a little differently. We led with infantry and the tanks were behind. So when the insurgents heard the tanks, they thought they could come out and get them. Unbeknownst to them they were coming out right into the infantry and were getting whacked. Little changes in tactics by the small unit leaders is the kind of innovation that we saw with the Marines in the city.⁶⁴

The Marines employed mechanized forces for a variety of purposes and in ever-imaginative ways. Tanks were a large target and drew fire to help identify enemy locations; they also served as a distraction/protection mechanism to enable other units to maneuver. An example of this adaptation in 1/8 Marines is shown in following pages, which show an excerpt of a published post-battle description by a rifle platoon leader in A Company, 1/8, Lieutenant Elliot Ackerman, of his platoon's integration of USMC tanks into their movement and fighting tactics on November 11 as they attacked south into the Government Center. Alongside the insert, we place our own comments in red to highlight to the reader this effective integration of combined arms by a USMC rifle platoon during the battle.⁶⁵

⁶⁴ Natonski, 2008, p. 25.

⁶⁵ Excerpted from 1st Lieutenant Elliot Ackerman, "Relearning Storm Troop Tactics: The Battle of Fallujah," *Marine Corps Gazette*, September 2006; also see Lester Grau, "Preserving Shock Action: A New Approach to Armored Maneuver Warfare," *Armor*, September-October 2006.

Immediately, the Marines from 1st Platoon engaged the enemy with direct fire, air, artillery, and 81mm mortars. As the enemy pinpointed the Platoon's position, they began to engage the Marines from multiple fortified structures. Some of the enemy had moved around the Platoon's northern flank and tucked into the buildings between 1st Platoon and Alpha Company. This made geometries of fire to the north very challenging.

Because the enemy had pinpointed the Platoon's position, rocket employment became very difficult. Marines could not remain exposed for an extended period to get off a good shot.

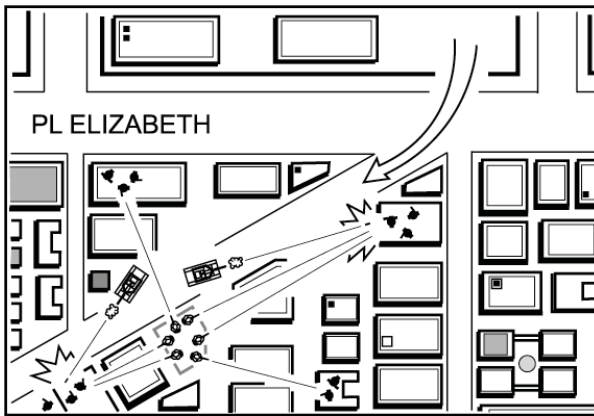

Map 3. 1st Platoon fights a series of tank-infantry engagements.

3. At this point, the tank section became invaluable. After multiple enemy positions had been located, the Platoon Commander called the tanks over the company tactical net and moved them from their cold position to a hot position adjacent to the Platoon. [TTP 401] As the tanks moved down the street, the Marines provided security for them from their overwatch position. [TTP 201, TTP 202] While the Platoon suppressed the enemy positions, the Platoon Commander talked the tank section onto the targets. Using multiple techniques in combination – the clock method, target reference points, and 7.62 tracer to mark targets – the Platoon Commander oriented the tanks onto their targets and the tanks proceeded to destroy the enemy positions one after another. [TTP 301, TTP 302]

The platoon has crossed the road and is isolated in a building south of the road, which was soon surrounded by enemy fighters.

Now the platoon brings a tank section across the road and positions it in a way that allows the tank to use its firepower and protection in complement with the riflemen in the buildings.

After all the known enemy positions were destroyed, the tanks moved back to their cold position. Throughout the course of the day, as the enemy attempted to reoccupy many of the buildings or moved to new buildings, the same process was repeated fifteen to twenty times. The Platoon would pinpoint the enemy's location, suppress the position, and then talk-on the tanks to destroy the enemy.

The same use of the tanks was repeated 15 to 20 times.

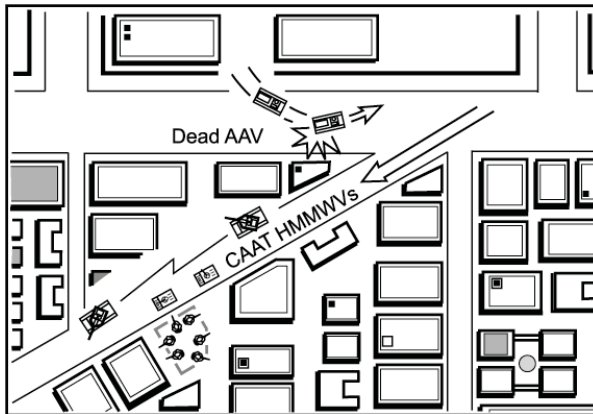

Map 4. Tanks screen HMMWV casevac.

4. That afternoon, the Platoon sustained two urgent casualties. One Marine was shot in the head and another was shot in his femoral artery. Time was critical.

The initial casevac was composed of one AAV that was destroyed by an enemy RPG north of the Platoon on Phase Line ELIZABETH.

The second casevac was made up of several CAAT vehicles. Before the CAAT vehicles could approach the Platoon, the tank section moved up to the casevac site and effectively suppressed the enemy to the north, west and south. This allowed the vulnerable CAAT vehicles to move in and pick up the casualties. The CAAT vehicles would surely have been destroyed if it was not for the effective screen provided by the tanks.

Here we see the problem Marines faced with using light-skinned AAVs to evacuate casualties. The figure depicts how the platoon positioned the tank section protect the damaged AAV and facilitate a CAAT heavy weapons team moving in and extracting the casualties.

Elliot Ackerman, "Relearning Storm Troop Tactics: The Battle of Fallujah," *Marine Corps Gazette*, September 2006, p. 4.

NOTE: AAV = amphibious assault vehicle; CAAT = combined anti-armor team.

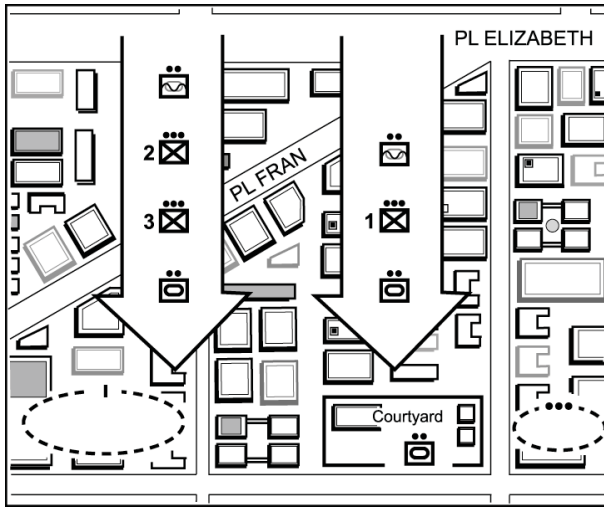

Map 5. Alpha Company attacks south on two parallel alleyways.

5. After the casevac, 1st Platoon continued to engage enemy targets with tanks. At 1500, the Platoon received a frago to **attack 200 meters to the south with the rest of the Company in order to destroy the enemy in zone.** The Company would attack and clear two parallel axis on adjacent alleyways.

The main body of the Company pushed out of the Government Complex with tanks in the lead, a main body of dismounted infantrymen following, and AAVs in the rear serving as armored ambulance and resupply vehicles. 1st Platoon conducted a linkup with the tank section that had been supporting them throughout the day.

At the time of the linkup, the only exit from 1st Platoon's position was effectively covered by enemy fire. The tank section suppressed the enemy positions around the Platoon, which allowed the Platoon to create an explosive breach in the building they occupied, and attack south with the tanks.

As the three rifle platoons attacked down the Company's two axis of advance, the infantry squads cleared houses until they made contact with the enemy. [TTP 204, TTP 205] Each time they made contact, the infantrymen called for tank support, which then destroyed the enemy-held building. While moving, the tanks were positioned at the front of the Platoon's column to engage targets of

Depicted on this page is a basic but profoundly important combination of light infantry and armor in a combat movement in an urban environment. Tanks lead and use their firepower and protection to engage difficult targets in buildings, while infantry move in a coordinated way to prevent enemy infantry from using close-in anti-tank fire to destroy the tanks.

As this battle description shows, Ackerman's 1st Platoon was able to integrate tanks into his platoon's actions at the Government Center on November 11 because they were made available to him. Although Marines understood the value of combined arms, mechanized vehicles were in short supply, and thus other USMC outfits fighting in Fallujah, such as 3/1 Marines (described by Sergeant Bennie Connor above), continued to fight in dismounted units without the support of heavy armor.

A sharp engagement that broke out on December 23, about a month after the battle of Fallujah "officially" ended, is another case in point. Historical accounts describe 3/5's attempt to root out dozens of insurgents dug into a neighborhood compound in Sector 19. The unit took heavy casualties (three KIAs and 20 wounded) before tanks—located three miles and 20 minutes away—arrived on site. Even the tanks' main gun rounds proved inadequate to eliminate the threat, however. Airstrikes were called in, delivering 15 JDAMs, and ultimately engineers used satchel charges to level the building.⁶⁶ This engagement stands out as a clear example of how Marines adapted their tactical methods on the ground by employing tanks (when possible) and adding the powerful impact of bombs and engineering ingenuity to finish the job. However, it was not before Marines suffered one of the heaviest days of casualties during Fallujah II, because they began the assault on the heavily defended building by stacking USMC rifle squads into the building without the support of armor or heavier firepower.

The preceding examples provide snapshots of battle that highlight the adaptation of USMC combat units in al Farj. The following section highlights the contours of battle from an Army standpoint and demonstrates that Army mechanized units came to Fallujah with their own imaginative vision for how to employ their assets in the urban terrain.

⁶⁶ Command Chronology for Regimental Combat Team 7, July–December 2004, provided to RAND by Matt Matthews; also see Lowry, 2010, pp. 254–255; Camp, 2009; Livingston, 2005.

Army Tactical Adaption in Fallujah II

During the planning phase in the weeks leading up to the battle, the initial tactical plans for RCTs 1 and 7 envisioned a more limited role for the two respective Army mechanized infantry TFs attached to them. But as planning progressed, both RCTs developed tactical plans that gave prominent roles to the two mechanized task forces. This was in large part the result of commanders from Army TFs sending liaison officers to the planning sessions to help “shape their course of action a bit, their concept, to something that was more in line with our capabilities.”⁶⁷

In RCT 1’s western sector, 2nd Battalion, 7th U.S. Cavalry Regiment (2-7 Cav), was given a separate zone to attack into the city with the mission of moving quickly down to PL Fran to secure it then move west to Jolan Park. The idea behind 2-7’s movement was for it to use its mobility, protection, and firepower to destroy enemy forces along the way and disrupt whatever C2 they had. Also, by attacking to secure Jolan Park, an assumed important location for the enemy fighters, 2-7 Cav would draw the enemy to it and be able to fight it on advantageous terrain, where it could use the firepower of its tanks and Bradleys to destroy them.⁶⁸ In a complementary way, the two USMC rifle battalions would attack south behind TF 2-7 and do the more detailed clearing necessary to destroy enemy forces bypassed by 2-7’s armored thrust.⁶⁹

The enemy was almost always reacting to U.S. forces; even if he initiated contact, U.S. forces had freedom of movement to react and quickly gain the initiative. Nonetheless, especially during the first days, which involved the heaviest fighting, it took adaptive measures to maintain momentum and prevent stout enemy defenses from the inside of buildings from slowing the American attack or causing alarmingly high casualty rates. One example of this kind of adaptation was the complementary use of small armored, mechanized teams from

⁶⁷ Matthews, 2015, p. 26;

⁶⁸ TF 2-2 in RCT 1’s eastern sector was used in similar ways, but differently, too, and is explained in more detail in a separate section below.

⁶⁹ Rainey, 2006, p. 11

2-7 Cav in the western sector to assist USMC rifle battalions having difficulty in clearing heavily defended buildings with USMC muscle power alone. As the previous section highlights, it was not uncommon for Marines, after making contact with enemy fighters in fortified positions inside buildings, to request either Bradley or tank support for firepower and protection to reduce these enemy fighters. 2-7 Cav also developed innovative use of its armored-mechanized teams by launching small tactical thrusts from PL Henry west into various parts of Fallujah to provoke enemy reaction and possible movement so that they could be destroyed. These mini-thrusts were done, at least in part, to draw enemy attention away from the USMC rifle battalions that were attacking south and west in conjunction with 2-7 Cav.⁷⁰

TF 2-2 also employed its mechanized assets in imaginative ways. When 2-2 first began to plan for the assault on Fallujah with their USMC higher headquarters, they were initially told that they would have the mission of isolating the eastern edge of RCT 7's sector for the assault.⁷¹ Lieutenant Colonel Newell and his planners believed that such a mission was not taking best advantage of the capabilities of an armored, mechanized infantry battalion task force and subsequently persuaded their RCT 7 commander, Colonel Craig Tucker, to give them an attack sector of their own. As Newell remembered, folks talk a lot about urban combat

being the right place for light infantry, but very few understood the power of a mechanized heavy battalion in an urban environment. As we looked at the plan and talked about the things we could do, they [RCT 7 Marine Headquarters] were very concerned about their Main Supply Route. . . . That was the only way they were going to be able to resupply . . . which was eventually

⁷⁰Interviews with LTC James Rainey, April 19, 2006, in Gott, 2006, Vol. I; interview with CPT Chris Brooke, in "Operational Leadership Experiences," Combat Studies Institute, Fort Leavenworth, Kan., May 4, 2006; interview with CPT Edward Twadell, February 28, 2006, in Gott, 2006, Vol. II; interview with Major Timothy Karcher, March 14, 2006, in Gott, 2006, Vol. I.

⁷¹Newell, 2006, pp. 4-5.

what drove them to give us? the eastern portion of the city with the role of getting to and opening Phase Line Fran.⁷²

In the revised plan, RCT 7 had its three combat battalions attacking abreast, from north to south with 1/8 Marines in the western portion of RCT 7's sector, 1/3 Marines in the center, and 2-2 Infantry in the east. The RCT's overall plan as part of the 1st Marine Division was to attack in sector to destroy enemy forces while moving south through Fallujah to secure it. Once both RCTs made it to PL Fran, which was the main road running east-west through Fallujah, RCT 7 would continue south, then swing west to the Euphrates, and RCT 1 would pivot on Fran and then attack due west to the Euphrates as well. However, that plan would eventually be modified.

The tactical plan of attack that Lieutenant Colonel Newell and his team developed shows imaginative thinking of a high order. The battalion faced a number of challenges that had to be overcome. First, 2-2 had only two tank/infantry company teams (whereas 2-7 Cav in the west had three). 2-2 did have task organized to it the brigade reconnaissance team (BRT), which had armored Humvees and, importantly, the Long Range Advanced Scout Surveillance System (LRAS), which was a powerful optical sight that could see 4-5 kilometers in the distance. Another significant challenge faced by 2-2 was that it was a mechanized infantry battalion with limited dismounted capability compared with the USMC rifle battalions. Whereas a USMC rifle battalion had 27 squads of infantry (at 13 men to a squad), 2-2 had only 12 (at nine men per squad). 2-2 was attacking abreast with two USMC rifle battalions on its right flank that each had a significantly greater capability to do detailed clearing of buildings with large amounts of infantry. Although a significant task assigned to 2-2 was to attack through sector to gain control of PL Fran (the MSR), which would allow for resupply of RCT 7 and RCT 1, it also had the task to destroy insurgent forces as they moved south. If 2-2 bypassed all enemy resistance, the Iraqi Army battalion that was following behind them would run into significant problems.

⁷² Interview with LTC Peter Newell, March 23, 2006, in Gott, Vol. I, 2006, p. 90.

So the tactical dilemma, or tactical problem to solve, for 2-2 Infantry was how to move to PL Fran quickly to secure it as a main supply route while being sure at the same time to destroy enough insurgent forces in sector to prevent them from disrupting the Iraqi Army moving behind 2-2 and the USMC regiments to 2-2's west. The orders 2-2 received from RCT 7 stated that TF 2-2 was to attack in zone to "destroy AIF [Anti Iraqi Forces]" and to "secure RCT 7's lines of communications . . . to camp Fallujah."⁷³

If 2-2 moved more slowly and deliberately to clear enemy forces, it would not secure PL Fran soon enough to satisfy USMC higher headquarters' need to have it as a supply line. Moving slowly and deliberately to clear enemy forces would also place a significant amount of stress on the limited number of infantry squads of dismounted infantry that 2-2 had on hand. Alternatively, if 2-2 moved very fast to PL Fran without destroying insurgent fighters, which it could do by remaining mounted in tanks and Bradleys and because the enemy had no real anti-tank capability beyond RPGs to slow 2-2's mounted movement, then it would potentially leave in its wake an undisturbed and very active enemy force. 2-2 Infantry therefore needed a balance between speed of movement and destruction of the enemy. Here is how they did it through planning, task organization, and execution.

In terms of task organization of combat power, 2-2 Infantry organized in the following way. It had three ground maneuver elements: a mechanized infantry company team with two infantry platoons, a tank platoon, and a combat engineer platoon (the engineer platoon had a mine-clearing line charge – MCLC – which played an important role in breaching the railroad track berm); an armor company team with one tank platoon and one combined tank/mechanized infantry platoon (a tank section of two tanks and a Bradley section with two Bradleys containing one infantry squad); and the BRT that was augmented with another combined tank/mechanized infantry platoon. Of note, the BRT consisted of two scout platoons each containing up-armored Humvees and the LRAS for long-range observations. Also attached to

⁷³ F Troop, 4th Cavalry, 3BCT Brigade Reconnaissance Troop, "Operation Phantom Fury History of Events," Provided to RAND by Matt Matthews, June 06 2015

TF 2-2 was a section of two 155 Paladin artillery pieces provided by 2-2's BCT commander, Colonel Dana Pittard. As the task organization in Figure 4.13 shows, TF 2-2 had considerable amounts of combat power, albeit with some limitations, especially in its ability to produce large amounts of dismounted infantry to clear buildings and ensure the destruction of enemy fighters.⁷⁴

The tactical plan that TF 2-2 put together effectively capitalized on the strengths of its task organization and also mitigated some of its weaknesses. TF 2-2 would conduct a combined arms breach of the railroad tracks using its engineer company to fire its MCLC to clear a lane for the two company teams to assault through and then attack from north to south abreast in sector to destroy enemy forces and seize PL Fran. 2-2's use of its BRT, augmented by a combined

Figure 4.13
TF 2-2 Task Organization

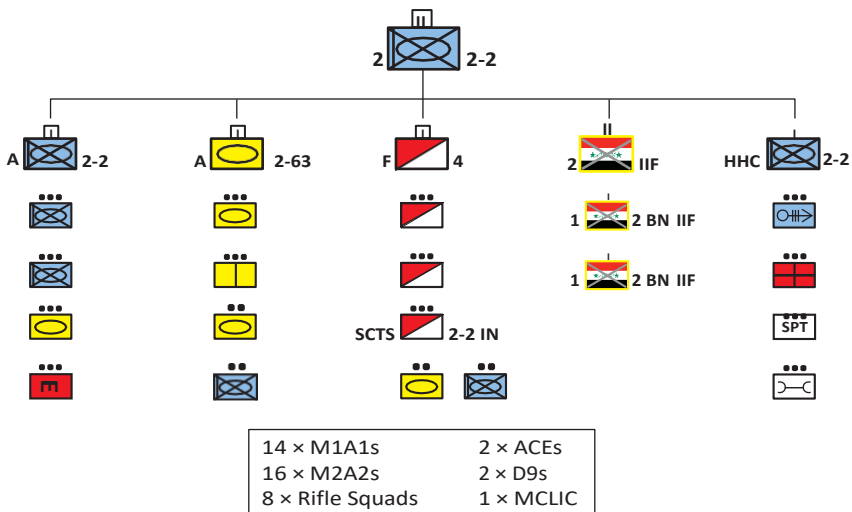

SOURCE: U.S. Army Combined Arms Center.

RAND RR1602-4.13

⁷⁴ Interview with Major Erik Krivida, February 6, 2006, in Gott, 2006, Vol. I; "Task Force 2-2 Spot Reports," provided to RAND by Matt Matthews, June 5, 2015; Newell, 2006; Memorandum for Record, Task Force 2nd Battalion, 2 Infantry, Operation Phantom Fury, January 2, 2005.

tank/mechanized infantry section, shows tactical imaginative thinking, because the BRT was placed on a road intersection in the very northwest corner of Fallujah, but not in the city itself, as the map indicates. Placing the BRT in this position and then, according to the plan, having it move south along the north-south running road immediately outside of the western edge of Fallujah's buildings would allow two things to occur: (1) as the tanks and Bradleys moved south, seeking out and engaging insurgent fighters either inside or outside of buildings, they would cause them to fall back in a southerly or easterly direction to avoid contact with the firepower of the tanks and Bradley; (2) as this was occurring, the BRT, in its slightly elevated position, would use its LRAS to observe enemy movement in the open in streets or on top of buildings and either call in indirect fires from the attached artillery section of two 155 howitzers or use the battalion's powerful 120mm mortar section. As one of the scout platoon leaders for the BRT, Lieutenant Chris Boggiano recalled that his platoon had the LRAS, which could see significant distances "and give a ten digit grid to whatever it was looking at, which was why it was great for calling artillery."⁷⁵

Also available to the BRT in the task organization was the combined platoon of two tanks and Bradleys. So in this imaginative tactical plan, 2-2's BRT combined the ability to observe significant distances and linking those observations of enemy movement to immediately responsive indirect fires, and whenever necessary the direct fire capabilities of two M1A1 tanks and two Bradley fighting vehicles with 25mm cannon.⁷⁶

Thus, the ground maneuver of 2-2s tanks and Bradleys would flush out enemy fighters into the open, while the BRT would engage those exposed enemy fighters with indirect and direct fires. 2-2's overall tactical plan to assault through its section of the eastern edge of the city capitalized on the strengths of the task force, which were firepower,

⁷⁵ Interview with CPT Chris Boggiano, July 20, 2006, in Gott, 2006, Vol. I.

⁷⁶ Interview with CPT Neil Prakash, October 20, 2006, in Gott, 2006, Vol. II. In Tal Afar, Iraq, in 2005, the Army's 3ACR fought using similar combined tank and Bradley teams; see Ricardo Herrera, "Brave Rifles at Tall Afar, September 2005," in William G. Robertson, ed., *In Contact! Case Studies from the Long War*, Fort Leavenworth, Kan.: Combat Studies Institute Press, 2006.

speedy mobility, and protection. It also mitigated one of TF 2-2's key weaknesses: lack of a dismounted capability to conduct extensive clearing of buildings and the destruction of the enemy within those buildings. Instead, the tanks and Bradleys would attack through the city, dismounting their infantry only when necessary, while the BRT in observation would do much of the killing of enemy fighters exposed by the mounted movement south.⁷⁷

After conducting the breach in the late evening of November 8, the tanks and Bradleys of the two company teams moved abreast through the far eastern sector of Fallujah. At least for the first three days of the battle, 2-2's plan was largely carried out. Figure 4.14 shows the movement of 2-2's two assaulting company teams through the breach of the railroad tracks and into the northeast edge of Fallujah. Note in the figure the positions of the BRT's scout platoons (containing the LRAS) and its tank and mechanized infantry sections on the right side of the graphic. The black arrows immediately to the left of each icon on the chart show their fields of observation and, for the tanks and Bradleys, their fields of direct fire. The tactical plan directed the two assaulting company teams to move south rapidly, destroying insurgent fighters along the way and forcing others to move either south or west, while the BRT's observations positions in the east allowed them to engage the exposed enemy in movement either by direct or indirect fires.⁷⁸

This plan solved a tactical problem for TF 2-2, and it created a significant tactical dilemma for the enemy forces it was confronting. If the enemy stayed in buildings to fight it out, TF 2-2, with its armored mechanized capabilities, had the firepower to destroy buildings, and it had enough dismounted capability to finish off enemy resistance

⁷⁷ Chris Boggiano, "A Co TF 2-2 Operation Phantom Fury," email to Matt Matthews, July 18, 2006; LTC Peter A. Newell, Memorandum for Record, Task Force 2nd Battalion, 2 Infantry, Operation Phantom Fury, January 2, 2005, provided to RAND by Matt Matthews, June 18, 2015; interview with SGM Peter Smith, June 6, 2006, in Gott, 2006, Vol. II.

⁷⁸ F Troop, 2015; LTC Peter A. Newell, Memorandum for Record, Task Force 2nd Battalion, 2 Infantry, Operation Phantom Fury, January 2, 2005, provided to RAND by Matt Matthews, June 18, 2015; interview with CPT Cristopher Lacour, May 15, 2006, in Gott, 2006, Vol. II; interview with SGM Peter Smith, June 6, 2006, in Gott, 2006, Vol. II; Boggiano, 2006.

Figure 4.14
Scheme of Maneuver and Observation Plan for TF 2-2's BRT (direction of attack is from north to south)

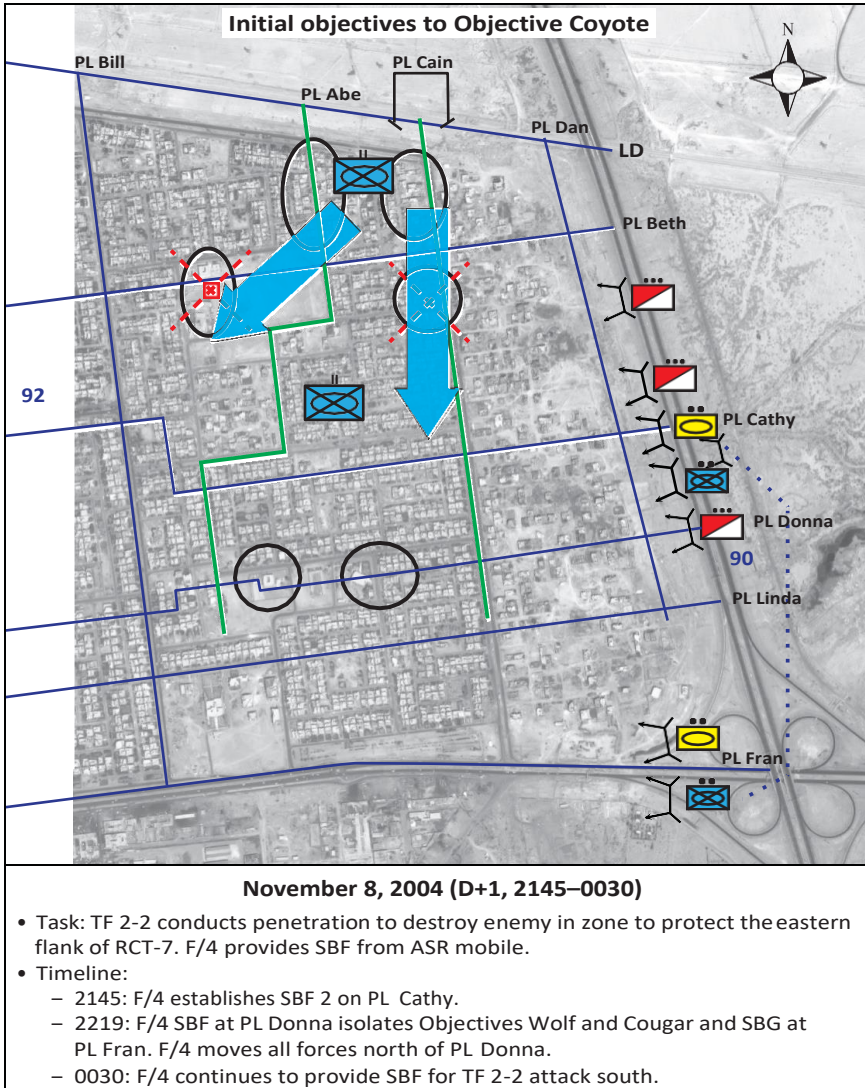

SOURCE: Google Earth image with overlay based on data from F/4 History of Events.

in buildings. If, however, the enemy decided to move and not confront armor/mechanized on streets and in buildings, he would then be observed by the BRT on the high ground to the west, which brings its own direct fires or calls for indirect fires on the exposed enemy. This synergy of effects enables 2-2 to do two things often at odds with a mechanized/armor battalion task force: move faster than light infantry because of its mobility, firepower, and protection, and at the same time use combined effects of maneuver and overwatching fires to clear enemy forces in an urban area.⁷⁹

The following monitored exchange between two insurgent fighters during the first five days of the battle shows the effect that this combination had on the enemy in Fallujah:

A: Where is the shooting?

B: Everywhere. In every area.

A: What is it, artillery?

B: Artillery, mortars and tanks everywhere . . .

A: Try to make it somewhere.

B: Even if I go in the yard I will be attacked.

A: What about Shuhada?

B: Just bombing there, they have not entered yet.

A: Listen, on the streets, it's just tanks right? Nobody on foot . . .

B: Yes but you see, a tank is roughly as big as a house . . . You can hit it with a rocket and it doesn't blow up . . .

A: Look, call me if anything develops. I don't care what time you call . . .

B: I'll do what I can. We did burn one tank.

⁷⁹ Bumbaugh, 2006; Command Chronology for Regimental Combat Team 7, July–December 2004, provided to RAND by Matt Matthews, June 18, 2015; interview with Captain Natalie Friehtl, July 28, 2006, in Gott, 2006, Vol. II; Avenger Company, 2004.

A: That's good at least.

B: Yes, but if you burn one tank they send three more. It's useless.

A: Two aircraft were brought down. Hang in there.⁸⁰

The exchange between these two insurgent fighters demonstrates the powerful effect of tanks – especially their mobility and protection – when combined with other forms of indirect fire such as artillery and mortars. The exchange also indicates, at least by implication, that insurgent fighters in the battle of Fallujah II would have rather confronted dismounted infantry moving on their own on the streets of Fallujah and without tank or other forms of mechanized vehicles in support.

It is no small coincidence that armored vehicles, largely impervious to gunfire and grenade shrapnel during the Fallujah fighting, were not present when the majority of recorded casualties were taken. Figure 4.15 indicates that guns (AKs, snipers, unspecified gunshots) and grenades produced the majority of the casualties; dismounted infantry were primarily the targets. Insurgents also became skilled at waiting out the overmatch, essentially blending into the urban landscape until armored units passed and dismounted infantry cleared an area, only to retake it later. As Natonski describes, “You might have an area go from yellow back to red when we went back in there clearing. That was probably the most difficult phase, and probably one of our highest casualties-producing elements.” On a related note regarding casualties, during the planning phase, commanders expressed concerns regarding the IED threat, identifying it as “the single biggest concern for causing casualties and losing momentum.” The data indicate that fewer than ten recorded casualties resulted from IEDs, suggesting the important role armored units played in mitigating this threat. This, together with the ability of combat forces in Fallujah to employ jamming devices to disrupt C2 capabilities for remote-controlled IEDs and to bring in direct and indirect fires to destroy suspected IEDs, and the possibility that the enemy chose to focus its efforts on internal defenses

⁸⁰ Quoted in Lowry, 2010, pp. 172–173.

Figure 4.15
Fallujah II Casualties, by Weapon

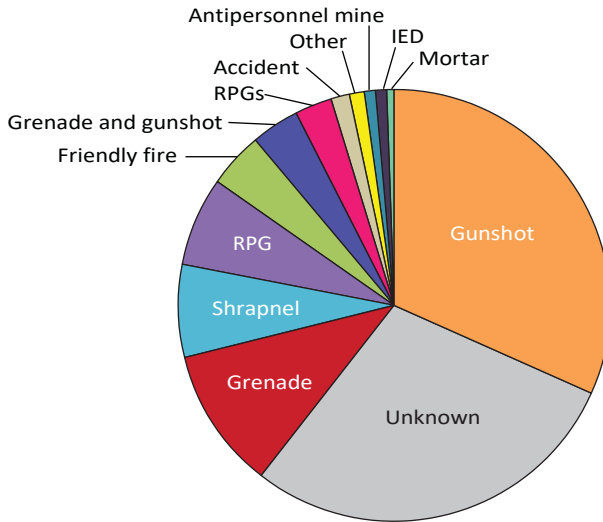

RAND RR1602-4.15

of buildings to kill Americans, seems to explain the low numbers of casualties caused by IEDs.⁸¹

The two Army mechanized battalion task forces that fought in Fallujah II took significantly fewer casualties than did the four USMC infantry battalions (Figure 4.16). There are a number of explanations for this disparity. First, USMC infantry battalions took more casualties because they simply had a much higher ratio of Marines on the ground than did the two mechanized battalions. Whereas the total combined number of dismounted infantry that both Army task forces could put on the ground in Fallujah was roughly around 200 riflemen, the four USMC infantry battalions combined placed roughly 2,000 USMC riflemen on the ground. In other words, there were many more Marines than Army soldiers on the ground susceptible to enemy attack and possible wounding or death. Another contributing factor to the higher number of USMC casualties was that it appears that the enemy

⁸¹ Natonski, 2008, pp. 33, 50; Camp, 2009, p. 130.

Figure 4.16
Fallujah II Casualties, by Unit

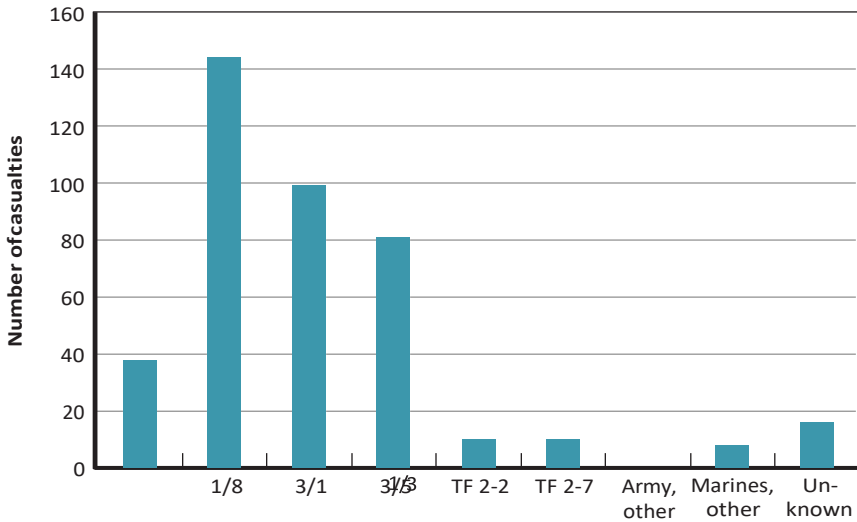

RAND RR16024.16

was avoiding combat with armored forces and preferred to fight it out with Marines (or Army mechanized dismounted soldiers) inside buildings, where the advantage of mobile protected firepower was negated. There was also the factor of the length of time that the four USMC rifle battalions and two Army mechanized battalions were actually in combat in Fallujah. 3/1 and 1/3 Marines and the two Army battalions departed around November 24, when the battle was deemed officially over, but 3/5 and 1/8 Marines stayed for another month, until roughly around the end of December, and met ongoing enemy resistance, which produced more casualties for each of these two USMC battalions.

However, and even after considering the above contributing factors to the relative higher number of USMC casualties, one must take into account the different tactical methods that USMC battalions started the battle with compared with the two Army mechanized battalions. Initially, the USMC approach was to rely primarily on light infantry marines to clear buildings and secondarily on either tank or firepower support. Conversely, the Army mechanized battalion tactic

was the opposite: Whenever dismounted infantry confronted stout enemy defenses inside of buildings, the method was to break immediate contact and then immediately bring in tank or Bradley firepower; indirect firepower from air assets, mortars, or field artillery; or some combination of all of these assets. As the battle progressed, the Marines did change to use this approach, but the initial approach and mindset of the Marines in Fallujah II certainly contributed to their higher ratio of casualties.

Mechanized units made a valuable contribution during Fallujah II, but they were no panacea. Tanks, Bradleys, and assault amphibious vehicles were limited in their ability to fire on positions where friendly forces may have been operating nearby. As one tanker explains, "When you're firing 25 millimeter, you can't just pull the trigger without knowing who's behind the building you're firing at. We didn't have that kind of situational awareness."⁸² Additionally, completely on their own in an urban environment, mechanized assets would be vulnerable to various forms of enemy action and had to be protected by dismounted infantry. As military historian Richard Lowry notes "Without infantry, the enemy could swarm the armored vehicles and hit them from all sides with RPGs and drop fire bombs and IEDs on the tanks from rooftops. Without infantry support they could take heavy casualties."⁸³ Richard Natonski's observations support the point: "You can take a tank out with a bullet if you hit it in the right place."⁸⁴

This is not to say, however, that in an urban combat environment dismounted infantry must always, a priori, be close to tanks and other armored vehicles. The trick is to strike the appropriate balance between dismounted infantry capacity and armor relative to the task and mission at hand. What the above analysis of TF 2-2's imaginative tactical plan shows is that such a balance is an imperative in urban operations. Captain Paul Fowler, who commanded the tank company team of TF 2-2, summed this up best when he recalled, shortly after the battle,

⁸² Brooke, 2006, p. 13.

⁸³ Lowry, 2010, pp. 102-103.

⁸⁴ Natonski, 2008.

that it is important to take the “lessons learned” from Fallujah II and apply them to

future battles. Use the heaviest force forward and follow with infantry to conduct detailed clearance behind the heavy force and prevent insurgents from trickling back into areas . . . already cleared. Synchronized combined arms fire and maneuver is devastating and [can] destroy any force that stands in . . . the way.⁸⁵

Although Fowler’s recommendation was based on the specific conditions of the battle of Fallujah, which had an enemy force with only limited anti-tank capabilities, his larger point of using mobile protected firepower to confront heavy enemy resistance in an urban environment is valid. But simply having the right mix of light and armored forces in an urban fight is not enough. Those forces must have the right organization; they must be trained and prepared in the art of combined arms warfare; and then, in conducting urban combat operations, they must be able to adapt quickly to extremely arduous conditions that will always be a part of the urban fight. In Fallujah II, joint planning before the battle enabled the USMC to incorporate combined arms effectively. Fallujah II demonstrates that these units were able to adapt quickly when conditions on the ground warranted. They did so by shrinking the urban combat problem to manageable proportions in a variety of ways.

⁸⁵ Avenger Company, 2004.

A Comparison of Approaches in Different Urban Population Settings

The specific problem this report has addressed is combat in urban areas. So far, the report has discussed urban operations in several locales, presenting each in some detail. This chapter turns to a cross-battle comparison of how the different approaches applied key aspects of successful urban combat operations.

Some common themes present themselves. First, maneuver is frequently channelized in urban areas, similar to mountainous terrain. Second, urban operations have traditionally been extremely costly to soldiers or any civilians remaining in the city. Third, the complexity of the urban area often provides the defender with distinct advantages and the ability to maintain the initiative.

As the Fallujah case study shows, a key aspect of being able to solve a combat problem in an urban area is to shrink its dimensions to one solvable with the capabilities and capacity of the available force. In Fallujah, this was accomplished in several ways. First, units surrounded the city and informed noncombatants that combat operations would soon commence within a specific timeframe and that, if they remained, they could be perceived as combatants. This was important for humanitarian and legal reasons, but also enabled much greater freedom of movement and application of firepower to destroy buildings when necessary and the enemy fighters in them and on the streets. Additionally, it took away one of the enemy's most effective weapons: the media effect. In this regard, the Marines in Fallujah experienced a learning curve similar to the Russians in Chechnya regarding the influ-

ence of the media. In both Grozny I and Fallujah I, the enemy successfully used a media blast to call attention to civilian wounded, alienate world opinion, and degrade local support. The Russians in Grozny II, however, had a much tighter grip on the media narrative; the Americans in Fallujah II evacuated the city's civilians, effectively taking that factor out of the equation altogether. This step proved useful in achieving the type of political will necessary to sustain the effort throughout the duration of the conflict, in contrast to the lack of political support during Fallujah I and Mogadishu years earlier.

In two of the cases examined earlier – the Second Battle of Grozny and the Second Battle of Fallujah – rules of engagement became highly permissive once noncombatants were given the opportunity to depart. In both cases, the city was an objective that had to be taken and cleared. This was accomplished by constantly reducing the area available to the enemy through fire, maneuver, and clearing operations. In both of these cases – similar to early urban fights during World War II in Aachen, Metz, and Berlin – the destruction in the cities was significant, and casualties were high on both sides. This occurs largely because of the advantages urban terrain confers to the defender, coupled with the preparation of the battlespace by the defender, the weapons available to both the defender and the attacker, and the competence of each.

Grozny and Fallujah presented problems to the attacker that resembled many of the urban operations of World War I: defeating a determined adversary who has chosen to make the city the battlefield. As the battles progressed, the urban terrain available to the adversary became increasingly constrained. By isolating and cutting off the cities, the ability of the adversary to reinforce was removed. Indeed, these two battles were seeming throwbacks to what many believe is a bygone period of warfare, in which high levels of collateral damage and casualties (by today's standards) are acceptable to accomplish the mission. The acceptance of collateral damage and highly destructive operations was made easier by the fact that noncombatants had the opportunity to leave the cities before operations began. The only way to defeat the enemy was to go into the city and fight.

The Fallujah case also shows that even with these important conditions in place to shrink the problem, tactics and fighting capability

still mattered. In Fallujah, imaginative thinking and tactical adaptation proved equally important to shrinking the problem down to manageable size. Arguably, if senior USMC leadership had not integrated the capabilities of its two armored-mechanized infantry task forces as it actually did, and if the USMC infantry battalions had not adapted tactically to lower casualties, the other important conditions might have been negated and the battle might have turned out very differently.

The 2008 Battle of Sadr City differed in several aspects. First, Sadr City's population – estimated as high as 2.4 million – dwarfed that of Fallujah or Grozny, which each had less than 500,000 residents before noncombatants departed.¹ Evacuation of the noncombatants, therefore, was not a viable course of action, given that they would have flowed into the rest of Baghdad, exacerbating an already difficult situation. Additionally, the prospect of going building-to-building inside of a densely populated urban slum measuring some 35 square kilometers was clearly not a viable option, given the prospect of significant non-combatant casualties and the sheer scale of the problem.²

As a result, Sadr City is a case where the U.S. Army had to apply armored forces using combined arms maneuver using large amounts of firepower for destructive purposes and in an urban environment where the population remained. To be sure, that was the type of urban environment the U.S. Army faced in Mogadishu, yet it failed in that case to shrink the problem successfully. Thus, Sadr City stands out from the others already discussed in this report for these very reasons.

One important constant, however, is shared by the battles in Fallujah and Sadr City, as well as in Grozny: the paramount requirement for mobile protected firepower to contend with enemy direct fire and IED/mine capabilities. Additionally, just as the Baghdad raids in April 2003 demonstrated the effectiveness of mechanized maneuver, it was equally effective in Fallujah II in the initial feints and as the actual

¹ Johnson, Markel, and Shannon, 2013, pp. 114–122; and Timothy L. Thomas, "Grozny 2000: Urban Combat Lessons Learned," *Military Review*, July–August 2000. Thomas writes: "Grozny had 20,000 to 30,000 residents still huddled in basements when the battle for the city began. These residents were too old, too afraid or too isolated to exit the city." Chechen fighters numbered some 4,000.

² Johnson, Markel, and Shannon, 2013, p. xv.

assault progressed. In both cities, there was a psychological factor to mechanized assets. Heavy armored vehicles rumbling down the street unhinged the enemy while boosting the confidence levels of U.S. and Iraqi infantry tasked with the dangerous job of engaging in close-quarter contact.³

Table 5.1 provides a useful comparison of how different forces applied some of these factors in efforts to shrink the problem of operating in an urban environment. None of the four methods for shrinking the problem—mobile protected firepower, reducing collateral damage,

Table 5.1
Comparing Methods to Shrink the Problem

Battle	Using Mobile Protected Fire for Maneuver	Reducing Collateral Damage	Planning and Training for Combined Arms Operations	Knowing the Enemy (Intelligence Preparation of the Battlefield)
Mogadishu	Not successful	Not successful	Not successful	Not successful
Grozny I	Somewhat/ eventually successful	Not successful	Not successful	Not successful
Grozny II	Successful	Successful	Somewhat/ eventually successful	Somewhat/ eventually successful
Baghdad	Successful	Successful	Successful	Somewhat/ eventually successful
Sadr City	Somewhat/ eventually successful	Successful	Successful	Somewhat/ eventually successful
Fallujah II	Successful	Successful	Somewhat/ eventually successful	Somewhat/ eventually successful

NOTE: In the third column, “Planning and Training for Combined Arms Operations,” the term *combined arms* is defined in the context of teaming armored vehicles with infantry but also at times combining other arms, such as close air support and indirect fires.

³ Avenger Company, 2004; Formica, 2004, p. 7; Lowry, 2010, pp. 114, 125.

planning and training for combined arms operations, and IPB—were successfully applied in Mogadishu, and only one was used successfully in Grozny I. Sadr City and Fallujah II, by contrast, included all four, albeit in different degrees.

The shrinking of the problem, therefore, in urban combat does not always necessarily mean just shrinking the large geographical space of a city down to manageable sizes and forcing the enemy into those areas to fight on favorable terms to the friendly force. It can also mean shrinking the effect of a variety of obstacles in a given urban combat environment down to manageable levels, so that superior friendly tactics can overcome them with relative ease. Even though these conditions were in place in several cases, they did not guarantee success once the assault began. In other words, a poor tactical plan of attack and, more important, poor execution of that tactical plan could have produced failure even with the surrounding conditions in place. In the case of the plan and execution for the November 2004 American assault on Fallujah, the intent was to attack through the entire physical expanse of the city and to capture or destroy to the extent possible the entire enemy force. Yet within this maximalist tactical plan and mission purpose, the First Marine Division fought in ways that reduced the effectiveness of the enemy force down to manageable proportions, although it took imaginative thinking and at times on-the-fly adaptation to do so.

It is important to note the important role intelligence operations played in increasing knowledge about the enemy and identifying effective ways to shrink the problem. For example, the broader battle for Baghdad against multiple sectarian factions showed the value of the targeted capturing or killing of high-value targets. Similar approaches are used by the United States across the globe against terrorists and by the Israelis (which they call “mowing the grass”) against their adversaries. This approach relies on exceptional intelligence, linked to prompt attack means, to locate and strike fleeting targets. The combination of physical isolation used in the 2008 Battle of Sadr City, enabled by excellent intelligence, points the way to a different approach to dealing with the challenges of future urban operations. Thus, future urban

combat operations should concentrate efforts on answering a number of key intelligence questions:

- Where is the enemy?
- How do you put pressure on him to consolidate in smaller areas?
- How do you create conditions to isolate the enemy?
- How do you create conditions to get the adversary to become visible and fight at a disadvantage to kill or capture them?
- How do you find and kill/capture high value targets?
- How do you find and secure critical materials?
- How do you deal with underground infrastructure?
- How do you deal with obstacles and IEDs?

This approach is discussed in more detail in the next chapter, but it is motivated by accepting the reality that it is not possible to execute IPB or JIPOE in a megacity to the levels our doctrine seems to demand for operational planning and risk mitigation. This is particularly true at the beginning of operations if extensive preparatory efforts have not already taken place. In essence, the problem that must be solved is locating and creating conditions where the adversary can be killed, captured, or made irrelevant, rather than controlling the city.

The Central Role of Intelligence in Future Urban Combat

To what extent is “better intelligence” a feasible solution to the challenges of urban operations, and how should the intelligence community go about producing it? This chapter examines the future of intelligence in an urban environment. First, it identifies three macro-trends: rising demand for intelligence in urban operations, increasing reliance on nontraditional collectors and data, and a shifting of the principal intelligence challenge from collection to integration. Second, this chapter looks toward solving the integration problem and analyzes the relative strengths and weaknesses of each intelligence discipline in a future urban environment. Finally, the chapter concludes with general recommendations about how to better prepare the intelligence enterprise for tomorrow’s urban operations.

Three Trends for Intelligence in Urban Operations

Three broad trends will likely shape the future of intelligence collection and analysis in urban warfare. First, urban operations will demand more and better intelligence. Second, increasing demand will likely force the Army and intelligence community to rely on new sources and methods of collection. Third, as a result of the first two trends, the principal challenge for intelligence in urban operations will continue to shift from collection, where collectors are scrambling for data, to integration, where analysts are trying to combine the plethora of

sources of information and make sense of it. This will often require the integration of these intelligence assets and functions with reconnaissance operations by combat forces that have the capability provided by mobile protected firepower to fight for information.

Increasing Demand for Intelligence

By nature, urban operations are intelligence- and reconnaissance-intensive. For example raids by ground forces using mobile protected firepower can collect intelligence on enemy positions and actions prior to more sustained offensive operations. Indeed, as Army doctrine ADRP 2-0, *Intelligence*, notes, intelligence staffs must fully examine all dimensions of ASCOPE – area, structures, capabilities, organizations, people, and events – to ascertain how the civilian population will shape an urban environment.¹ This requirement adds layers of complexity not found in operations in unpopulated, rural terrain and can increase the demand for intelligence considerably. Especially in unconventional warfare, where the civilian population often outnumbers the number of enemy combatants, understanding the civilian population can be an equally time- and resource-consuming task as more traditional enemy-centric analysis.

Looking forward, the demand for intelligence will continue to increase for two reasons. First, urban areas will grow in terms of population, geographical size, and complexity. In its *Global Trends 2030: Alternative Worlds*, the National Intelligence Council predicts that by 2030 roughly 60 percent of the world's population – some 4.9 billion people in total – will live in urban centers.² Indeed, it notes that “every year, 65 million people are added to the world's urban population, equivalent to adding seven cities the size of Chicago or five the size of London annually.”³ Megacities – those with 10 million or more residents – will continue their exponential growth, from three world-

¹ Army Doctrine Reference Publication 2-0, *Intelligence*, Washington, D.C.: Headquarters, Department of the Army, August 31, 2012, p. 5-3, paragraph 5-15.

² National Intelligence Council, 2012, p. v.

³ National Intelligence Council, 2012, p. 2.

wide in 1980 to 24 in 2014 to an estimated 37 by 2025.⁴ As cities grow, more intelligence will be needed to understand them.

More debatably, the U.S. military will likely continue to shift to more intelligence-intensive urban warfare strategies. In the past, many combatants' approach to urban operations consisted of surrounding the city center, ordering noncombatants to leave, and then clearing it block by block, destroying any resistance in the process. Indeed, multiple cases over the past two decades – including the Russians in Grozny, the Israelis in Jenin, and the United States in Fallujah – fit this model. In all three cases, the United States, Israel, and Russia used firepower to compensate for a lack of intelligence, a blunt but often effective tradeoff.

In the future, this option may not be viable. Logistically, resettling a megacity with 10 million or more inhabitants is likely impractical. Even if it is possible to resettle a portion of the city, this approach will likely be increasingly legally and morally unacceptable. Indeed, Colin H. Kahl, political scientist and national security adviser to Vice President Joseph Biden, argues that the U.S. military has increasingly attempted to minimize noncombatant casualties since the Vietnam War and will likely continue to push toward greater precision and target discrimination in the future.⁵

Moreover, there are also international political reasons for this trend. Civilian casualties can reduce support for war efforts both at home and abroad.⁶ Additionally, as the Director of National Intelligence notes, in the coming decades, “metropolitan regions will spill over multiple jurisdictions creating mega-regions. By 2030, there will be at least 40 large bi-national and tri-national metro regions,” where

⁴ Douglas E. Batson, “Black Spots Are No Treasure Island: Land Tenure and Property Rights in Megacities,” in Charles Ehlschlaeger, ed., *Understanding Megacities with the Reconnaissance, Surveillance, and Intelligence Paradigm*, Vicksburg, Miss.: U.S. Army Research and Development Center, April 2014, pp. viii, 36.

⁵ Colin H. Kahl, “In the Crossfire or the Crosshairs? Norms, Civilian Casualties, and U.S. Conduct in Iraq,” *International Security*, Vol. 32, No. 1, Summer 2007, pp. 7–46.

⁶ See Eric V. Larson and Bogdan Savych, *Misfortunes of War: Press and Public Reactions to Civilian Deaths in Wartime*, Santa Monica, Calif.: RAND Corporation, MG-441-AF, 2007.

megacities straddle multiple national boundaries.⁷ Evacuating such cities would have huge international effects. In sum, if present trends hold true, the future of urban combat in terms of needing to account for the size and concentration of the population will look more like Baghdad and less like Fallujah: The military will need to shrink the problem through more and better intelligence.

Increasing Reliance on New Sources and Methods of Intelligence

This demand for intelligence introduces the second major trend that will shape intelligence efforts in urban combat in the future: a shift to new sources and methods for intelligence collection. Intelligence efforts face a similar problem as combat forces do when operating in large urban environments: The sheer size of megacities can quickly overwhelm intelligence communities' ability to collect. Consequently, as the demand for intelligence in urban operations grows, it will increasingly outstrip the ability of traditional ISR assets' collection capability, for three reasons.

First, on the most basic level, the intelligence budgets are – according to current budget projection – unlikely to keep pace with the growth of urbanization. In FY 2015, the Congressional Budget Office projected that overall defense spending would increase by roughly 1.2 percent over the next 15 years, or by roughly 20 percent in 2030 in inflation-adjusted dollars.⁸ Much of this funding, however, will cover rising personnel costs, even though the overall force size will shrink.⁹ Within acquisition, the share of the Army's budget projected to be spent on ISR platforms is projected to pale in comparison to other procurement priorities, such as modernizing its aircraft, acquiring a new ground combat vehicle, and strengthening missile defense.¹⁰

Second, cities are, by their nature, "hard targets" and likely to only become "harder" in the future. Cities' complex physical terrain and siz-

⁷ National Intelligence Council, 2012, p. 28.

⁸ Congressional Budget Office, *Long-Term Implications of the 2015 Future Years Defense Program*, Washington, D.C., November 2014, p. 1.

⁹ Congressional Budget Office, 2014, p. 2.

¹⁰ Congressional Budget Office, 2014, p. 32.

able civilian populations offer ample opportunities to hide, complicating the task of separating combatants from civilians. Even bracketing the friend-or-foe question, just knowing who lives in cities is often challenging enough. According to one study, of the 6 billion properties in the world today, some 4.5 billion are unregistered – that is, without a formal title or deed.¹¹ Particularly in urban slums, good census data are hard to come by, and urbanization and population growth will only exacerbate the needle-in-haystack problem.

Finally, most traditional intelligence platforms work best when they are narrowly focused on a specific target and layered on top of each other, so that different intelligence disciplines (imagery, signals, human, etc.) can play off of each other's strengths. This method of intelligence collection, however, creates a fundamental paradox. On the one hand, to pare down the city into a more manageable problem set, one needs to collect quality intelligence on the specific neighborhoods where the enemy is concentrated. At the same time, to develop quality intelligence, one often already needs to have a relatively narrow collection focus.

This emerging supply-and-demand gap will force the Army to develop new ways to expand intelligence production, starting with expanding the number of intelligence collectors. The Army is already pursuing this option. For example, under the Regionally Aligned Forces concept, the amount of collection could expand dramatically. As General Raymond Odierno explained,

Before the most recent set of conflicts, it was generally believed that cultural awareness was only required in select Army units, such as Special Forces or Civil Affairs. Recent history has made clear that we need expanded levels of cultural and regional awareness in *all* Army units. So, in the simplest terms, regionally aligned forces are Army units and leaders – Brigades, Divisions, Corps, and support forces – who focus on a specific region within

¹¹ Batson, 2014, pp. 38–39.

their normal training program by receiving cultural training and language familiarization.¹²

Whether or not Odierno's belief in the importance of cultural awareness is correct is questionable (after all, cultural familiarity may matter less if the Army faces a conventional fight against a resurgent Russian adversary than if it were fighting a counterinsurgency). Less questionable, however, is that using Regionally Aligned Forces as a collection method is an old intelligence technique applied in new ways: It builds on the earlier concepts of "every soldier a sensor," where the entire force becomes a means for intelligence gathering, now just applied to peacetime.¹³

Another, arguably more novel solution to meet the expected increased demand is to tap new sources of data. "Smart Cities" offer a potential windfall for intelligence for urban operations. According to the Director of National Intelligence,

Smart cities are urban environments that leverage information technology-based solutions to maximize citizens' economic productivity and quality of life while minimizing resource consumption and environmental degradation. In smart cities, advanced IT capabilities are the foundation of urban planning, governance, resource-management, physical infrastructure, communications infrastructure, building design, transportation systems, security services, emergency services, and disaster response systems.¹⁴

Smart cities are not just a Western phenomenon. In fact, the intelligence community assesses that by 2030, Asia, Africa, and Latin America will lead advances in this area.¹⁵ Consequently, it is quite pos-

¹² Raymond T. Odierno, "Regionally Aligned Forces: A New Model for Building Partnerships," *Army Live – The Official Blog of the United States Army*, March 22, 2012.

¹³ For an explanation of the "every soldier a sensor" concept, see Stew Magnuson, "Army Wants to Make 'Every Soldier a Sensor,'" *National Defense Magazine*, May 2007.

¹⁴ National Intelligence Council, 2012, p. 86.

¹⁵ National Intelligence Council, 2012, p. 87.

sible that the Army may find itself conducting operations within a smart city in the future.

Smart cities offer new opportunities for intelligence collection. Emergency services data – tracking crime, unrest, fires, and the like – help narrow areas where combatants can target their more traditional ISR assets. Police cameras – originally intended for crime prevention – can double as a military surveillance asset. Real-time traffic data can ensure that the U.S. military maintains freedom of movement within cities teaming with millions of inhabitants. Department of Motor Vehicles data can provide a starting database of names, photographs, and contact information. Water and electricity grid data can provide vital knowledge and potential point of leverage for any combatant who can manipulate them.

Private data sources – everything from private citizens with cell-phone cameras to companies' security cameras – could be an even greater boon for intelligence gathering. Indeed, one U.S. Army Combined Arms Center report argues that the world is entering the age of “ubiquitous global surveillance”:¹⁶

The private use of drones, closed circuit television, and satellites will allow social media users, bloggers, and traditional media outlets to secure live feeds of any event on the globe within minutes and proliferate them immediately. . . . By 2030, the increased availability of commercially manufactured drones, portable cameras, and wireless bandwidth will make it possible to track nearly all activity in public spaces in near real time.¹⁷

Even if the world falls short of tracking *all public activity*, there is no doubt that the proliferation of technology increases the potential pool of information sources exponentially.

¹⁶ U.S. Army Combined Arms Center, *The Human Dimension White Paper: A Framework for Optimizing Human Performance*, October 9, 2014, p. 9.

¹⁷ U.S. Army Combined Arms Center, 2014.

A Shift from a Collection to an Integration Problem

These new intelligence opportunities will produce the third and probably most significant trend – shifting the principal intelligence challenge in urban warfare increasingly away from collection to integration. In previous eras, the question was how to collect enough data to understand what was happening inside urban areas. For much of human history, spies and captured prisoners offered rare glimpses into what was happening behind locked city walls.

As more sources of public and private data become available from a range of collectors, however, the challenge will not be collecting data, but integrating and analyzing it all. Already, the Army has struggled to integrate existing intelligence sources. The existing platform for integrating intelligence – the Distributed Common Ground System – is expected to cost over \$11 billion and take over 30 years to build, and it remains controversial.¹⁸

The integration problem will only increase in the future. The challenge already exists in some measure for Regionally Aligned Forces. Soldiers with in-country experience (from Regionally Aligned Forces or otherwise) tend to be tracked only on an ad hoc basis. Since soldiers regularly rotate units and determinations about who deploys where are based on a variety of factors apart from regional expertise, there is no guarantee that those who have local knowledge will be in the right place in the event of the crisis. Consequently, the Army may possess this baseline intelligence capability within its ranks but not capitalize on it.

Fully leveraging the data from smart cities will pose an even more significant technical challenge. Software will need to be designed to “smooth” (or standardize) and then import these data, a particularly thorny task because the available inputs will vary by city and the United States may not know where it will fight ahead of time. New methods for querying these data will need to be developed, so as to allow analysts to manipulate and analyze the vast pools of available information.

¹⁸ Gordon Lubold and Shane Harris, “Exclusive: Pentagon Withholds Internal Report About Flawed \$2.7 Billion Intel Program,” *Foreign Policy*, March 18, 2014; also see Austin Wright, “The Army’s Multibillion Dollar ‘Money Pit,’” *Politico*, May 29, 2013.

Classification hurdles – overlaying unclassified and sensitive information to a common operating picture – will need to be hammered out in real time.

Solving the integration problem for intelligence in future urban environments will require more than resolving these technical challenges, however. It will also demand new conceptual thinking about the strengths and weaknesses of the various intelligence disciplines in an urban setting and how they can be fully leveraged within an urban environment. This is the subject of the next section.

The Intelligence Disciplines in the Future Urban Warfare

The urban environment poses unique challenges and opportunities for each intelligence discipline, making some potentially more or less relevant, depending on the length and duration of the mission at hand. Specifically, the growth of the ratio of population to intelligence collectors in urban environments will increase the attractiveness of utility of open source information and more-technical forms of intelligence. That being said, technological advancements specific to each discipline are needed to access the wealth of intelligence each discipline can provide.

Open Source Information Will Increase in Scale and Importance, Particularly Early in Operation

As previously alluded to, perhaps one of the greatest shifts in the intelligence disciplines will come in open source information. In the past, open source information primarily focused on a relatively small number of traditional media outlets, but this increasingly is no longer the case. According to the World Bank, the number of Internet users globally more than doubled between 2005 and 2013 – from 15.8 to 38.1 per 100 people.¹⁹ Even more important, the trend – with a handful of exceptions, such as the Democratic Republic of Korea – is global.²⁰

¹⁹ World Bank, “Internet Users (Per 100 people),” undated.

²⁰ World Bank, undated.

As Internet use has expanded, so too has the use of the social media. According to some estimates, the number of social media users globally has risen by over 60 percent from 2010 to 2013, from 970 million to 1.59 billion, and is projected to increase to 2.44 billion by 2018.²¹ As a result, there is more information from a broader array of sources – all unclassified and publicly available – than ever before.

Just as important, today's open source information is increasingly unfiltered, free from editorial and government constraints, and consequently a potentially more valuable intelligence source. While censoring newspapers, radio stations, and television shows is a well-developed practice, recent attempts by authoritarian regimes to control the Internet have produced mixed results. In 2011, the Hosni Mubarak regime tried to take the Internet in Egypt offline in attempt to quell anti-government protests.²² In 2012, the Syrian government managed to take about 90 percent of Syria's Internet offline in an effort to repress a growing anti-government movement, although technological firms such as Google attempted to develop alternative ways to access the Internet.²³ And in 2013, protestors shut down Libya's Internet service, after storming the building of the country's largest providers.²⁴ Outside the Middle East, China is well known for restricting Internet and social media access and recently drafted new laws authorizing broad powers on the subject.²⁵ Importantly, in most of these cases, people managed to circumvent these restrictions, and even in China there are

²¹ Statista, "Number of Social Network Users Worldwide from 2010 to 2018 (in Billions)," 2015.

²² Noam Cohen, "Egyptians Were Unplugged, and Uncowed," *New York Times*, February 20, 2011.

²³ Doug Gross, "Syria Caused Internet Blackout, Security Firm Says," *CNN*, December 3, 2012. According to former National Security Agency employee Edward Snowden, the National Security Agency was accidentally responsible for this action (Spencer Ackerman, "Snowden: NSA Accidentally Caused Syria's Internet Blackout in 2012," *The Guardian*, August 13, 2014).

²⁴ BBC, "Protesters Force Libya Internet Shutdown," *BBC News*, December 21, 2013.

²⁵ Kristie Lu Stout, "China's Great Firewall: Fortune at the Expense of Freedom?" *CNN*, March 25, 2015; Gerry Shih, "China's Draft Cybersecurity Law Could Up Censorship, *Irk Business*," *Reuters*, July 8, 2015.

active attempts to skirt government censorship.²⁶ In Egypt, Libya, and Syria, attempts to shut down the Internet may have been initially successful but ultimately ended in failure, suggesting that even when operating against dictatorial regimes, open source information will remain a valuable source of information.

The rise of social media also allows for new forms of open source information analysis. While in previous generations open source information focused largely on “what was said,” today the “where” and “who” questions can prove equally important. Social media enables the mapping of networks – who is talking to whom – and since many also allow for geolocation, it can provide the “where” as well. These data can prove a valuable source for intelligence. For example, a RAND study used Twitter data to study the protests in Iran surrounding the 2009 election.²⁷ Similarly, another analysis, led by University of Washington researchers, showed the utility of Twitter data in predicting the protests in Egypt and Tunisia.²⁸

As a result of the increasing volume, decreasing constraints on speech, and opening up of new forms of exploitation, open source information will likely play an increasingly important role in intelligence analysis, especially early on in an operation, as intelligence staffs attempt to define the contours of their operating environment. Open source information will play an increasingly important role in urban operations in particular, given that these areas often tend to have more access to the Internet – not to mention a more educated population that want their voices heard – than more rural areas.

Open source information also has noticeable drawbacks. The sheer volume of open source information produced in a megacity can quickly overwhelm the intelligence community’s ability to analyze it

²⁶ For example, see Beina Xu, “Media Censorship in China,” Council on Foreign Relations Backgrounder, April 7, 2015.

²⁷ Sara Beth Elson, Douglas Yeung, Parisa Roshan, S. R. Bohandy, and Alireza Nader, *Using Social Media to Gauge Iranian Public Opinion and Mood After the 2009 Election*, Santa Monica, Calif.: RAND Corporation, TR-1161-RC, 2012.

²⁸ Philip N. Howard, Aiden Duffy, Deen Freelon, Muzammil Hussain, Will Mari, and Marwa Mazaid, “Opening Closed Regimes: What Was the Role of Social Media During the Arab Spring?” *Project on Information Technology and Political Islam*, working paper, 2011.

all. Moreover, as Georgetown's Kalev H. Leetaru and Army Engineering Research Development Center analyst Charles R. Ehlschlaeger note,

Most of the new emerging megacities have not historically been locations of substantial interest to Western policymaking needs. The knowledge of the media system and cultural narratives of a city like Dhaka, especially its slum areas, pales compared with the vast expertise on Moscow assembled over many decades of intense focus.²⁹

They also note that urban slums also often tend to have lower Internet and social media usage rates, leaving gaps in open source information collection.³⁰ These limitations notwithstanding, however, open source information will play an increasingly important role in driving urban operations in the years to come.

To optimize the amount and quality of information gathered from open source information, several technological developments are necessary. Monitoring websites and social media accounts is labor-intensive. For example, Chinese Internet companies employ about 100,000 people who work continuously to police the web.³¹ The military does not have the capacity to devote these types of resources to open-source information monitoring, thereby making it necessary for technology to enable analysts to track certain web sites, particularly social media platforms, with fewer analysts. For example, combining automated social media processing with immediate translation would enable analysts to flag in real time social media posts containing certain key words and access the information in them without language barriers hindering the process. This would drastically cut back on the

²⁹ Kalev H. Leetaru and Charles R. Ehlschlaeger, "Modeling the Discourse of Megacities: Assessing Remote Populations in the Non-Western Worlds," in Charles R. Ehlschlaeger, ed., *Understanding Megacities with the Reconnaissance, Surveillance, and Intelligence Paradigm*, Vicksburg, Miss.: U.S. Army Research and Development Center, April 2014, p. 77.

³⁰ Leetaru and Ehlschlaeger, 2014, p. 79.

³¹ "The Economist Explains: How Does China Censor the Internet?" *The Economist*, April 21, 2013.

volume of social media posts analysts would need to sift through to find actionable intelligence. Even then, the volume of posts returned could exceed the capacity of analysts. If the purpose of collecting this open source information data is to gain a general sense of a foreign population's attitude toward an issue, analyzing a small sample of the returned posts could suffice. If the purpose of collecting the data is to gain exact information from a specific unknown source, however, the ability of automated social media monitoring to provide the intelligence needed may be limited. Moreover, accuracy would inevitably be a problem with this type of technology, as automated processing struggles to detect sarcasm and slang.

Social media, particularly photo-centric platforms such as Facebook and Instagram, also provide ample opportunities for intelligence gathering. To maximize the benefits of photos posted on social media, facial recognition technology is needed to enable analysts to piece together incomplete images that are automatically flagged as a result of the subject's features. Some of this development is being done in the realm of smartphone applications (apps). One such app enables users to take a photo of a stranger and match that person based on his or her facial features with other websites, including dating websites and criminal databases.³² This type of technology could have military uses, especially if crafted for drones that can fly over areas where it may be difficult for human assets to go. For example, a target leaving a building and entering a car could be seen by a drone, but placing a human asset there to verify that person's identity at just the right time would be difficult. Moreover, drones can be used to see into the windows of tall buildings or into courtyards that could be difficult for human assets to enter in an urban environment.

Human Intelligence Is Less Useful (at Least Initially)

If open source information is more useful in future operations, human intelligence (HUMINT) will become more difficult, at least until the problem is isolated to a specific region or group. As defense analysts

³² Michelle Starr, "Facial Recognition App Matches Strangers to Online Profiles," *CNET*, January 7, 2014.

Jamison Jo Medby and Russell W. Glenn write, “The masses of people in an urban area simultaneously provide more sources of information in the form of HUMINT (human intelligence) and act to overwhelm the collection and analysis that all-source intelligence can provide.”³³ The logic behind Medby and Glenn’s observation is relatively straightforward. For example, the chances that any New Yorker will personally know another one are relatively slim. Once the problem is narrowed down to a set neighborhood (e.g., the upper West side of Manhattan) or to a specific community, however, the chances that a recruited asset will know the target in question increase dramatically.

Indeed, HUMINT collection during the Iraq War confirmed some of Medby and Glenn’s analysis. According to media accounts, during the initial stages of the insurgency, the Central Intelligence Agency and military intelligence struggled to set up and validate their own networks of informants. In fact, the Army’s initial 69 tactical HUMINT teams generated only a quarter of the expected daily number of reports in 2003.³⁴ And at least in one Baghdad-based commander’s estimation, much of what was collected tended to be more rumors than genuine intelligence.³⁵ The delay occurred for several reasons—the difficulty in setting up HUMINT networks before the invasion, fears among potential sources about retribution, and unfamiliarity with the human terrain making it difficult to vet sources.³⁶ Whatever the reasons, these incidents underscore the difficulty at developing reliable HUMINT early on in operations.

HUMINT has other drawbacks for the U.S. military. Unlike the other intelligence disciplines, HUMINT is labor-intensive. At its core, it involves soldiers talking to other people, and as a result there are

³³ Jamison Jo Medby and Russell W. Glenn, *Street Smart: Intelligence Preparation of the Battlefield for Urban Operations*, Santa Monica, Calif.: RAND Corporation, MR-1287-A, 2002, p. 5.

³⁴ Ricks, 2006, p. 193.

³⁵ Peter R. Mansoor, *Baghdad at Sunrise: A Brigade Commander’s War in Iraq*, New Haven, Conn.: Yale University Press, 2008, pp. 47–48.

³⁶ Walter Pincus, “An Intelligence Gap Hinders U.S. in Iraq,” *Washington Post*, December 24, 2004.

fewer ways to substitute capital for labor than in some of the more technical intelligence disciplines. Moreover, while all patrols can collect HUMINT on some level from their regular interactions with local populations, more sophisticated HUMINT also can take time, as sources with the right placement and access are developed and run. Finally, high-quality HUMINT often requires good language skills, and unless the U.S. Army finds itself in another English-speaking country, the force is not guaranteed to have enough native language speakers on hand.

HUMINT can become a far more important tool – especially early on – if the United States already has the benefit of local allies to provide an existing network, focus HUMINT collection efforts, and mitigate the language barriers. Indeed, in the Second Battle of Grozny, the Russians found that reliable local allies transformed the value of HUMINT. As Fort Leavenworth Foreign Military Studies Office analyst Timothy Thomas concluded in his analysis of the battle,

And, unlike the first battle, this time Chechens were used to fight Chechens ([Grozny mayor Bislan] Gantamirov's force), a practice which overcame many problems associated with tactics and language in the city. Chechen combatants friendly to the federal cause and led by Gantamirov could talk with the local population and get intelligence on the rebel positions and dispositions. Chechen human intelligence often proved more valuable than Russian signal intelligence.³⁷

Using local allies for HUMINT collection, however, can pose a classical principal-agent problem. These actors have their own motivations for cooperating, and their interests rarely perfectly accord with American ones. Rather than providing unbiased information, these actors then may try to manipulate the intelligence they provide to achieve their own objectives and settle old scores. As a result, even in these cases, HUMINT reports need to be cross-checked with other intelligence disciplines.

³⁷ Thomas, 2000, p. 57.

Signals Intelligence Will Need to Rely on More-Automated Forms of Analysis

Though counterinsurgency often is thought of as a HUMINT-intensive form of warfare, in the Iraq and Afghanistan wars, signals intelligence (SIGINT) played an important role in driving operations, particularly in more urban areas. Media accounts quoted General David Petraeus, commander of Multi-National Forces–Iraq, crediting the combination of SIGINT and cyber warfare “with being a prime reason for the significant progress made by U.S. troops” during the 2007 Surge by directly leading to the death or detention of almost 4,000 insurgents.³⁸ Political scientists Jacob Shapiro and Nils Weidmann found that increased mobile phone coverage correlated with decreased insurgent violence on both a district and a local level in Iraq between 2004 and 2009.³⁹ Indeed, as testament to its increasing role and importance during the first decade of the Global War on Terrorism, the National Security Agency – the lead intelligence agency for SIGINT – saw its work force grow by a third and its budget roughly double in size.⁴⁰

SIGINT’s value likely will only increase in the decades to come, particularly in urban areas. Even in relatively underdeveloped countries, urban residents increasingly have and use cell phones. As Leetaru and Ehlschlaeger note, “While at first it might seem counterintuitive to utilize cell phone data to map the urban flow of megacities, especially their slum areas, they are in fact one of the richest data sources on realtime population movement.”⁴¹ Just as the proliferation of mobile communications and Internet will fuel an increase in the value of open source information, it will also be a potential boon for SIGINT as well.

³⁸ Shane Harris, “How the NSA Became a Killing Machine,” *The Daily Beast*, November 11, 2014.

³⁹ Jacob N. Shapiro and Nils B. Weidmann, “Is the Phone Mightier Than the Sword? Cell-phones and Insurgent Violence in Iraq,” *International Organization*, Vol. 69, No. 2, Spring 2015, pp. 247–274.

⁴⁰ Dana Priest, “NSA Growth Fueled by Need to Target Terrorists,” *Washington Post*, July 21, 2013.

⁴¹ Leetaru and Ehlschlaeger, 2014, p. 81.

Like open source information and HUMINT, however, SIGINT will need to wrestle with a potential imbalance in the ratio of collection to analysis capacity. Given the number of people and the sheer volume of communication, the potential amount of collection in a megacity could rapidly exceed analysts' ability to process it all. Especially because much of SIGINT is highly classified, finding a sufficient pool of linguists eligible to hold top-level security clearances may prove particularly difficult. That said, unlike HUMINT, SIGINT could rely on technical and automated means of sifting through the data, at least initially, to narrow down the problem set to a manageable level.

SIGINT in urban environments faces a series of technical challenges, too. Even today, militaries often communicate using radios, but most urban residents use alternative means of communication: cell-phones, text messages, emails, and the like. SIGINT collection, therefore, will need to adapt its collection techniques based on the nature of the target. Moreover, the built-up infrastructure in cities and amount of communications equipment in a limited geographic space can pose challenges for SIGINT collection. Buildings, power lines, trolley lines, and other staples of the urban terrain can interfere with radio communications, for example.⁴² Nonetheless, SIGINT has increasing potential for future urban operations.

Imagery Intelligence Will Need to Exploit Nonmilitary Collection Sources

As in other environments, overhead imagery intelligence (IMINT) from UASs can serve as an important C2 tool, enabling commanders to watch an operation develop and see their own forces respond in real time. Some experts see these platforms playing an even larger role in the future. Major General Robert P. Ashley, then commander of U.S. Army Intelligence Center of Excellence, for example, suggested, "using smaller, hovering-type unmanned aerial systems to monitor trouble

⁴² Training Circular 2-91.4 *Intelligence Support to Urban Operations*, Washington, D.C.: Headquarters, Department of the Army, December 2015, p. 1-11.

spots within a large urban area.”⁴³ Such a concept would have to overcome several potential challenges – from high-rise buildings restricting line-of-sight control to navigating already potentially crowded airspace.

IMINT, when combined with other technical intelligence sources and precision-strike capabilities, can also make for a powerful targeting tool. Indeed, one study of the 2008 Battle of Sadr City concluded,

Persistent ISR, technical intelligence, and responsive precision-strike capabilities (afforded by attack helicopters, fixed-wing CAS, UASs, and GMLRS) were fundamental to success and must be integrated. To be absolutely clear, coalition forces could not have achieved the same results at the same cost without these capabilities.⁴⁴

Developing these standoff capabilities becomes all the more appealing given the risks of casualties in urban combat.

Perhaps, the area for the most potential, however, will come from nonmilitary IMINT sources. Already deployed by law enforcement and domestic intelligence agencies across the globe, security and crime prevention cameras are an increasingly common feature of urban terrain. These cameras can prove to be particularly powerful tools in the aftermath of incidents, perhaps as best demonstrated by the July 7, 2005, terrorist bombings in the London public transport system. After the attacks, authorities conducted

the biggest CCTV [closed-circuit television] forensic examination ever attempted in the United Kingdom, not only because of the growth in the numbers of CCTV cameras in London in recent years, but also because of the spread-out nature of the multi-location terrorist attacks.⁴⁵

⁴³ Quoted in Bill Hess, “Army Intelligence Looking to Combat Future Enemies: Conference Begins Today on Fort,” *Sierra Vista Herald*, December 7, 2014.

⁴⁴ Johnson, Markel, and Shannon, 2013, p. 106.

⁴⁵ Glen M. Segell, “Terrorism on London Public Transport,” *Defense & Security Analysis*, Vol. 22, No. 1, March 2006, p. 52.

Using this footage, investigators were not only able to track the bombers' movement within London proper, but eventually to Leeds, some 230 miles away from the city.⁴⁶

To make CCTV into a more proactive rather than investigative tool, intelligence staffs will need to mitigate the imbalance between the numbers of sensors to the number of observers. For example, in 2013, *The Telegraph* reported that the United Kingdom has one CCTV camera for every 14 people, more than 4.9 million cameras in total. It noted that some estimates were even higher, with a ratio of one CCTV per 11 Britons.⁴⁷ While the United Kingdom is likely on the high end in terms of numbers of cameras, especially compared with many of the environments the United States will find itself in the future, the fact remains that the U.S. Army likely will not have enough analysts to monitor all the feeds simultaneously.

As a result, if the U.S. military wants to turn these networks from an investigation tool post event into a collection tool that can be used in real time, it will need to rely on some form of automated cueing — where computers scan these multitude of feeds, identify possibly noteworthy activity, and alert analysts to follow up from there.⁴⁸ To an extent, this is already under way. For example, law enforcement agencies already use audio sensors to detect gunshots to cue their responses.⁴⁹ Making automated scanning work effectively in cases where there are no shots fired or distinctive military equipment to serve as audio or visual cues may prove more difficult.

There are also significant developments in automated cueing with video imagery. One Israeli company, MATE Intelligent Video, has

⁴⁶ Segell, 2006, p. 53.

⁴⁷ David Barrett, "One Surveillance Camera for Every 11 People In Britain, Says CCTV Survey," *The Telegraph*, July 10, 2013.

⁴⁸ For more discussion, see Amado Cordova, Lindsay D. Millard, Lance Menthe, Robert A. Guffey, and Carl Rhodes, *Motion Imagery Processing and Exploitation (MIPE)*, Santa Monica, Calif.: RAND Corporation, RR-154-AF, 2013.

⁴⁹ For example, see Andras Petho, David S. Fallis and Dan Keating, "ShotSpotter Detection System Documents 39,000 Shooting Incidents in the District," *Washington Post*, November 2, 2013.

developed video technology that can detect changes in landscapes and alert personnel, though this may have limited uses in an urban rather than a rural environment.⁵⁰ This type of technology could be developed for an urban context and would be particularly useful if combined with facial recognition technology or other types of biometric intelligence to enable analysts to determine when a target has entered an environment.

Biometric Intelligence Will Pay Dividends, But Only in Certain Longer Duration Missions

Biometric intelligence became an increasingly important collection asset during the Iraq and Afghanistan Wars. Essentially, the idea was to deprive insurgents of one their greatest assets – anonymity – by constructing a massive database of the local population’s biometric data, specifically their fingerprints, iris scans, and facial features.⁵¹ Recovered IEDs or weapon caches would then be dusted for fingerprints, run against the database, and, hopefully, matched to a person. The Biometric Automated Toolset (BAT) was first introduced in operations in Kosovo in 2001 and later employed in both Iraq and Afghanistan. The Army fielded the Handheld Interagency Identity Detection Equipment – a smaller camera sized collection tool – in the spring of 2007.⁵² Already by September 2007, the database numbered some 1.5 million entries and had produced some 167 matches to latent fingerprints found on IEDs.⁵³

Since then, the biometric intelligence has expanded. In October 2012, the Defense Intelligence Agency opened an Identity Intelligence Project Office.⁵⁴ In 2013, the Federal Bureau of Investigation’s fingerprint database included 110 million fingerprints, the Department of

⁵⁰ Abigail Klein Leichman, “Israel’s Top 12 Video Surveillance Advances,” *Israel21c*, April 23, 2013.

⁵¹ U.S. Army, “Introduction to Biometrics and Biometric Systems,” undated, p. 7.

⁵² U.S. Army, undated, p. 8.

⁵³ Biometrics Task Force, “Biometric Automated Toolset (BAT) and Handheld Interagency Identity Detection Equipment (HIIDE),” September 19, 2007, p. 11.

⁵⁴ Biometrics Task Force, p. 11.

Defense (DoD) had 9.5 million, and the Department of Homeland Security's contained 156 million.⁵⁵ According to media accounts, DoD also is developing new ways to collect biometric data, including building UASs with the capability to map and recognize human faces.⁵⁶

Biometric intelligence's utility, however, varies greatly by mission and context. For instance, it may prove less useful for traditional force-on-force engagements. After all, if the opposing force is wearing uniforms, there is not necessarily the same need to identify people by their biometric data. On the technical front, biometric reporting tends to be data-intensive, and cross-checking entries against existing databases rapidly consumes bandwidth. Insufficient bandwidth already poses a problem for troops in more-austere environments, and as the database grows and moves to the "cloud," these technical hurdles could increase.⁵⁷

The operational hurdles are equally great: collecting biometric data from more than 10 million inhabitants in a megacity will be a slow, laborious process at best, and perhaps impractical altogether. To make biometric intelligence pay dividends, the collection effort would need to be targeted, and even then it could take time before the database was large enough to turn biometrics into an intelligence tool. Like HUMINT, biometrics likely will prove a useful intelligence tool in urban operations, but only for longer-term operations, once the other intelligence disciplines isolate the problem within a megacity to a select area, and only in certain kinds of operations.

Though making biometrics a useful intelligence tool may take time, many different biometrics could be used to identify potential targets aside from those traditionally utilized, such as fingerprints and facial recognition. Investing in technology that maximizes the usefulness of these other biometrics now will enable the military to pick and choose which type of biometric intelligence it gathers and uses

⁵⁵ Ben Iannotta, "Biometrics: A New Intelligence Discipline," *Defense News*, May, 13, 2013.

⁵⁶ Noah Shachtman, "Army Tracking Plan: Drones that Never Forget a Face," *Wired*, September 28, 2011.

⁵⁷ Spencer Ackerman, "Army's Fingerprint and Iris Database Heads for the Cloud," *Wired*, May 30, 2013.

depending on which is optimal for the situation. For example, visual biometrics, such as the shape of an individual's ear, hand features, and walking style, could be useful in identifying targets from open source information and IMINT sources.⁵⁸ Voice biometrics could also be used in SIGINT and enable analysts to match voice characteristics from a variety of sources, such as captured telephone calls or videos posted on social media websites.

History Can Form Its Own Intelligence Discipline, and Combat Is Another Type of Intelligence

Finally, while not particularly novel or technologically sophisticated, perhaps the best form of intelligence on how adversaries will fight in urban centers in the future is by continuing to study how actors fight in urban centers today. In this sense, combat is its own form of intelligence. This applies in the micro-sense — once the Army is in combat, past encounters with adversaries can be used to form and refine doctrinal templates for how the enemy will fight in the future.

History, as an intelligence discipline, can apply in the more macro-sense as well. Adversaries learn from each other, across regions and over time. As a result, it remains vitally important that the Army continues to research how Russia operated in Crimea, how ISIL operated in Ramadi and Fallujah, and how Hamas operates in Gaza. Even if the U.S. Army does not directly end up fighting any of these actors specifically, these past encounters can yield clues about the future of conflict, painting a broad picture that more technical skills can help refine later on. So while it is important that the Army embraces new means of intelligence collection for urban combat, it needs also not to forget perhaps the oldest one of all: History can be its own intelligence discipline.

⁵⁸ Biometrics Institute, "Types of Biometrics," 2015.

Expanding Intelligence Capacity for Urban Warfare

Given these macro-trends as well as urbanization's likely implications for each of the intelligence disciplines, what can be done today to ensure that there is more robust intelligence support for urban operations tomorrow? This analysis prompts several recommendations for military intelligence going forward.

Doctrine

In some sense, intelligence in the urban environment requires anything but a doctrinaire approach, because analysts need to look for new ways to expand intelligence production, often through incorporating nonmilitary sources in novel ways. Therefore, intelligence doctrine for future urban environment should counsel against overly rigid thinking or tunnel vision-like reliance on solely traditional, classified sources of intelligence.

Organization

As noted earlier, the Army already is expanding its cultural and language awareness through programs such as Regionally Aligned Forces. The challenge going forward is ensuring that the Army remains flexible enough – as an organization – to capitalize on the benefits of these programs. The Army will need to ensure that soldiers get enough exposure to a region to gain actual expertise. It then needs to track these soldiers – perhaps through an additional identifier – and then build the assignment system so that qualified soldiers can be readily tapped, should the need for this expertise arise. All this will require rethinking military career paths, so that such skills are rewarded and encouraged. Finally, the Army needs to understand that, as much as language and cultural skills have been important for the most recent wars, they may be less critical to future ones, especially if the Army finds itself fighting a more conventional military. Accordingly, the Army needs to take these programs for what they are: an important possible source of intelligence, but not necessarily a panacea or a substitute for more traditional sources of intelligence.

Training

Future intelligence analysts need to train how to use existing civilian resources to augment more traditional military sources into their analyses. The Army should rotate analysts through operations centers in major urban centers and push them to think through how data – already collected by police, fire departments, and utility companies – might be used in intelligence preparation of the operating environment. The same goes for training analysts on social media. While many soldiers already use these tools on an individual basis, not all appreciate its potential in the professional realm.

Materiel

New technologies will be key to successfully processing and integrating the vast amount of data needed to understand future urban environments. In particular, as the amount of collection grows in relation to the number analysts, software that enables automated cueing – identifying abnormal or suspicious activity – will become increasingly important to solving the sensor-observer imbalance. New solutions will also be needed to store and then access the collected data in a timely fashion. This may also include ways to increase classified bandwidth. Perhaps, above all, materiel solutions need to be focused on developing new integration software that enables both classified and open source information data to be overlaid on top of each other in real time to develop a common operating picture.

Leadership

Perhaps a prerequisite for many of these changes is a supportive leadership. More directly, turning non-intelligence personnel into collectors will produce valuable intelligence only with a supportive leadership. Even beyond retasking personnel, however, the shift toward open source information will occur only if leadership both within and without the intelligence community value this form of analysis and appreciate its utility and insight, despite its lower classification level.

Personnel

Preparing for the intelligence field to handle the challenge of the urban environment will also require personnel changes in at least three areas. As already mentioned, to meet the increase in demand for intelligence, intelligence staffs will need to incorporate the skills of non-intelligence personnel. Some projects – such as Regionally Aligned Forces or “every soldier a sensor” – already hit at these concepts. Other military occupational specialties – such as civil affairs, engineers, and public affairs – help round out the expertise of the intelligence section in understanding the physical and human dimensions of complex urban terrain. Second, in terms of intelligence personnel specifically, the Army may need to train specific open source and social media analysts, as it does HUMINT or SIGINT analysts, as this area becomes increasingly important. Finally, the Army will need to continue to wrestle with the challenge of maintaining sufficient numbers of linguists in its ranks. While the Army should continue to promote and maintain language skills through incentives such as language pay, given the unpredictability about where the next operation will occur, it also needs to maintain the capacity for rapid expansion of the number of linguists in the ranks, either by hiring contractors or through direct enlistments.

Facilities

One of the often underappreciated challenges of tactical intelligence is ensuring that all the relevant parties can access the information. Part of this task relates to who can hold a security clearance, but part of it also relates to which facilities can store classified information. In urban warfare, where units are spread throughout a sector in small patrol bases, many lack regular access to sensitive compartmented information facilities (SCIFs) and so lack regular access to intelligence products. If much of the future urban warfare strategy rests on substituting the blunt use of force through more precise operations guided by better intelligence, then the Army will need to be able to push SCIFs down to lower levels of command and develop new ways to construct these facilities – and ensure their connectivity – even in austere environments.

Policy

In the policy realm, perhaps the largest concerns relate to the legal implications surrounding the increasing importance of open source information. New policies will define what information analysts are allowed to collect and how to train analysts on this form of intelligence, while ensuring adequate protection for American civilian liberties. Especially as the world becomes increasingly interconnected, this task becomes increasingly difficult.

Conclusion

In sum, intelligence can provide a start to enabling the Army to operate successfully within megacities — or any urban environment, for that matter. If intelligence staffs embrace new sources and methods of data collection and can integrate this information to create actual intelligence, the Army may be able to reduce the relevant operational area to a scope that it actually has the resources to handle. Moreover, if intelligence staffs are able to synchronize and integrate their functions with combat reconnaissance operations, they will further the effort to shrink the mass of an urban operation down to reasonable proportions. Shrinking the problem, however, will require the intelligence community to rethink the utility of each of the intelligence disciplines in an urban environment and how they piece together to fit the broader effort.

That said, perhaps, a final note of caution is warranted. Even if the United States adopts all of the above recommendations, this still may not enable the Army to isolate a problem to a subset of a future city. In Grozny and Fallujah, for example, the adversary maintained freedom of movement, at least until the start of operations. In these cases, while intelligence may be able to identify an adversary's strong points, it may not function as the combat-power-saving tool some may hope it will be. Indeed, as demonstrated in the other case studies in this volume, time and again, armies have needed to turn to blunt force when confronting cities' challenges. And while one would hope that improving intelligence mitigates the need to resort to these tactics in the future, the Army also needs to prepare contingencies if this form of precision warfare fails.

Operations in Urban Areas: Implications for the Army

What can we learn from past urban operations – both from an offensive and a defensive perspective – to inform changes across DOTMLPF-P¹ and to inform approaches to address the Army Warfighting Challenges? This chapter turns to the implications of urban warfare for the Army. It begins by describing the effects of urban combat on specific warfighting challenges. It then moves to a discussion of urban combat and DOTMLPF-P.

Operations in Urban Areas: Implications for Warfighting Challenges

Develop Situational Understanding

The previous chapter on intelligence discussed much of this across the DOTMLPF-P. The case studies further reinforce the importance of HUMINT in understanding the specific urban area in question. Given the challenge of a large urban area, these efforts to understand the challenges presented by specific urban areas should be an ongoing area of analysis within the joint, interagency, intergovernmental, and mul-

¹ See *Manual for the Operation of the Joint Capabilities Integration and Development System (JCIDS)*, February 12, 2015. DOTMLPF-P is the acronym for the areas assessed in the JCIDS process to identify and recommend integrated solutions to capability gaps in the areas of: doctrine, organization, training, materiel, leadership and education, personnel, facilities, and policy.

Army Warfighting Challenges

The long list of Army Warfighting Challenges is included here because they will be addressed later in this chapter. The Army Warfighting Challenges are the “Enduring first-order problems, the solutions to which improve the combat effectiveness of the current and future force.” The website has a detailed set of learning demands for each warfighting challenge. A shorter version lists the 20 Army Warfighting Challenges and the first-order learning demand for each.

1. **Develop Situational Understanding:** How to develop and sustain a high degree of situational understanding while operating in complex environments against determined, adaptive enemy organizations.
2. **Shape the Security Environment:** How to shape and influence security environments, engage key actors, and consolidate gains to achieve sustainable security outcomes in support of Geographic and Functional Combatant Commands and Joint requirements.
3. **Provide Security Force Assistance:** How to provide security force assistance to support policy goals and increase local, regional, and host nation security force capability, capacity, and effectiveness.
4. **Adapt the Institutional Army:** How to maintain an agile institutional Army that ensures combat effectiveness of the total force, supports other services, fulfills DoD and other agencies’ requirements, ensures quality of life for Soldiers and families, and possesses the capability to surge (mobilize) or expand (strategic reserve) the active Army.
5. **Counter Weapons of Mass Destruction:** How to prevent, reduce, eliminate, and mitigate the use and effects of weapons of mass destruction (WMD) and chemical, biological, radiological, nuclear, and high yield explosives (CBRNE) threats and hazards on friendly forces and civilian populations.
6. **Conduct Homeland Operations:** How to conduct homeland operations to defend the Nation against emerging threats.
7. **Conduct Space and Cyber Electromagnetic Operations and Maintain Communications:** How to assure uninterrupted access to critical communications and information links (satellite communications [SATCOM], positioning, navigation, and timing [PNT], and intelligence, surveillance, and reconnaissance [ISR]) across a multi-domain architecture when operating in a contested, congested, and competitive operating environment.
8. **Enhance Training:** How to train Soldiers and leaders to ensure they are prepared to accomplish the mission across the range of military operations while operating in complex environments against determined, adaptive enemy organizations.

9. **Improve Soldier, Leader and Team Performance:** How to develop resilient Soldiers, adaptive leaders, and cohesive teams committed to the Army professional ethic that are capable of accomplishing the mission in environments of uncertainty and persistent danger.
10. **Develop Agile and Adaptive Leaders:** How to develop agile, adaptive, and innovative leaders who thrive in conditions of uncertainty and chaos and are capable of visualizing, describing, directing, and leading and assessing operations in complex environments and against adaptive enemies.
11. **Conduct Air-Ground Reconnaissance:** How to conduct effective air-ground combined arms reconnaissance to develop the situation rapidly in close contact with the enemy and civilian populations.
12. **Conduct Joint Expeditionary Maneuver and Entry Operations:** How to project forces, conduct forcible and early entry, and transition rapidly to offensive operations to ensure access and seize the initiative.
13. **Conduct Wide Area Security:** How to establish and maintain security across wide areas (wide area security) to protect forces, populations, infrastructure, and activities necessary to shape security environments, consolidate gains, and set conditions for achieving policy goals.
14. **Ensure Interoperability and Operate in a Joint, Interorganizational and Multinational Environment:** How to integrate joint, interorganizational, and multinational partner capabilities and campaigns to ensure unity of effort and accomplish missions across the range of military operations.
15. **Conduct Joint Combined Arms Maneuver:** How to conduct combined arms air-ground maneuver to defeat enemy organizations and accomplish missions in complex operational environments.
16. **Set the Theater, Sustain Operations, and Maintain Freedom of Movement:** How to set the theater, provide strategic agility to the joint force, and maintain freedom of movement and action during sustained and high tempo operations at the end of extended lines of communication in austere environments.
17. **Integrate Fires:** How to coordinate and integrate Army and Joint, Interorganizational, and Multinational (JIM) fires in combined arms, air-ground operations to defeat the enemy and preserve freedom of action across the range of military operations.
18. **Deliver Fires:** How to deliver fires to defeat the enemy and preserve freedom of action across the range of military operations.
19. **Exercise Mission Command:** How to understand, visualize, describe, and direct operations consistent with the philosophy of mission command to seize the initiative over the enemy and accomplish the mission across the range of military operations.
20. **Develop Capable Formations:** How to design Army formations capable of rapidly deploying and conducting operations for ample duration and in sufficient scale to accomplish the mission.

tinational arenas, particularly the geographic combatant commands, their Army service component commands, and the institutional Army. Each urban operation discussed in this report poses unique challenges and opportunities that lend themselves to analysis before operations. Finally, integrating local forces into offensive or defensive urban operations can markedly increase situational awareness and understanding.

Provide Security Force Assistance

In the final battle for Grozny and the Battle of Sadr City, indigenous security forces were an important combat multiplier. Another example of the effectiveness of ISF occurred during the Battle of Fallujah in November 2004. TF 2-2 Infantry, under Lieutenant Colonel Peter Newell, integrated an Iraqi Army battalion into its tactical plan of action. Newell appreciated the strengths and weaknesses of the Iraqi Army battalion attached to his task force and gave it the mission of moving behind his armored task force to clear any enemy fighters remaining in buildings. Since the Iraqi battalion had only small arms and were mounted on Toyota trucks, he gave them a mission that they could handle within the capabilities that they had. Or, in other words, he did not give them a mission that was beyond their capabilities.

The use of Gantamirov's militia forces in Grozny and ISF in Sadr City and Fallujah conferred legitimacy to the operations and provided local knowledge and intelligence. In the case of Grozny, the implication is perhaps more in the realm of unconventional warfare operations. In the case of Sadr City, the ISF came of age in the battle and secured Sadr City after the battle.² Although the state of the ISF has markedly declined in the aftermath of the U.S. withdrawal from Iraq, efforts to improve it are under way as a means to fight ISIS.³ Nevertheless, in both the Grozny and Sadr City battles, external forces provided the vast majority of the competent ground forces, fires, and other key enablers. It is highly doubtful that local forces could have won either of

² Johnson, Markel, and Shannon, 2013, p. 28.

³ David E. Johnson, "Fighting the 'Islamic State' The Case for U.S. Ground Forces," *Parameters*, Vol. 45, No. 1, Spring 2015, pp. 9-12.

these fights independently, but they did provide invaluable capabilities to the commanders of the operations.

Conduct Space and Cyber Electromagnetic Operations and Maintain Communications

The urban environment presents significant challenges and opportunities in this area. The challenge is to “assure uninterrupted access to critical communications and information links”⁴ within the operational and tactical contexts of a large urban area, particularly within the interiors of large buildings and in subterranean locations. The specifics of the individual urban environment will inform an understanding of how to confront these challenges. Maintaining secure communications while inside Grozny presented different challenges than those faced by Coalition Forces operating outside of Sadr City.

The Battle of Sadr City shows that there are also significant opportunities to exploit electromagnetic operations to find and kill or capture adversaries.⁵ Nevertheless, U.S. forces have not operated in an urban environment where the adversary can exploit or disrupt communications since World War II. This may not be the case in the future, even against nonstate adversaries.

Enhance Realistic Training

Realistic training for urban operations is a real challenge, given the difficulty of replicating any large urban area. That said, tactical training can be and is being executed in smaller-scale facilities. The important issue is that of providing problems that are relevant to the tactical situations formations units will face in actual operations. These include the challenges of multistory buildings, the effects of urban congestion on maneuver, and operating in subterranean areas; the list is almost endless and, again, is specific to a city. It transcends a generic system-

⁴ Army Capabilities Integration Center, *Army Warfighting Challenges*, Fort Eustis, Va., June 29, 2015.

⁵ Stanley A. McChrystal, *My Share of the Task*, New York: Penguin, 2014, pp. 101–111; Peter Mansoor, *Surge: My Journey with General David Petraeus and the Remaking of the Iraq War*, New Haven, Conn.: Yale University Press, 2013, pp. xv, 293.

of-systems approach and solution set. Each city is different, and training at the tactical level should be designed to present a range specific challenges.

At the operational and strategic levels, training for urban combat, particularly in megacities, will require simulations and exercises to train staffs for the complexities they present. The CSA SSG has been involved in early efforts to this end, and its recommendations should be published and assessed for further incorporation into Army gaming and in developing training tools for the brigade and above echelons. Additionally, staff rides to U.S. megacities and partnerships with their nations' forces will enable staffs to gain a better understanding of the nature of the megacity and become aware of the agencies that can be leveraged in future operations, e.g., police and fire departments.

Conduct Wide Area Security

This challenge, again, depends a lot on the specific urban area and whether the force is involved in offense, defense, or stability operations. In Grozny, the Russians obtained wide area security by killing, capturing, and displacing Chechen rebels. Protecting infrastructure was not a consideration. Indeed, the systematic destruction of infrastructure was part of the operation. The population was "protected" by forcing it to evacuate. In Fallujah, wide area security was attained by the defeat of the insurgents and the evacuation of the citizenry before the operation. Both Grozny and Fallujah were very destructive operations. In Grozny, the destruction of the city was intentional. In Fallujah, damage to the city was unavoidable.

Operations during the Battle of Sadr City focused on establishing wide area security in Baghdad by ending the threat posed by JAM maneuver and fires. The eventual methods employed to defeat JAM forces drew them out of the city by presenting a dilemma they could not tolerate: cutting off the market areas contiguous to Sadr City. JAM became visible and was placed in a position of tactical disadvantage. Wide area security was restored through its defeat.

What these three cases show is that wide area security is obtained principally through the defeat of adversaries in combat. If the adversary cannot be flushed into the open, Grozny and Fallujah offer examples of

how to establish wide area security. If it is possible to create dilemmas for the adversary that makes him visible, then the techniques employed in Sadr City may be feasible at a much lower cost in terms of friendly casualties and destruction.

Finally, in defensive operations, the objective is to create a dilemma for the enemy that appears not solvable at acceptable costs. In essence, make it unimaginable to the adversary that *he* can achieve wide area security.

Conduct Air-Ground Reconnaissance

In all of the cases discussed in this report, the United States and its partners enjoyed air supremacy above man-portable air-defense system (MANPADS) ranges. Therefore, they were able to conduct unfettered air reconnaissance. The Russians enjoyed the same advantage in the battles for Grozny. In future offensive operations, this may not be the case, particularly in offensive and defensive operations against state actors with capable air defenses. Consequently, the importance of ground reconnaissance will increase in environments not currently familiar to the Army, e.g., subterranean and multistory. Furthermore, adversaries with stand-off weapons (ATGMs, RPGs, rockets) will increase the demands for mobile protected firepower in reconnaissance elements.

Conduct Joint Combined Arms Maneuver, Integrate Fires, and Deliver Fires

These three Army Warfighting Challenges are deeply interrelated and highly contextual. In Grozny and Fallujah, the operational environment and the adversaries' actions resulted in the heavy use of fires to support maneuver. Indeed, in the final battle for Grozny, the robust suppression of Chechen rebels was a precondition for maneuver, a hard lesson learned from the first Grozny battle. In Fallujah, fires were also used rather freely to support maneuver. In Sadr City, there were two simultaneous fights involving combined arms: the battle along the Gold Wall to defeat attacking JAM militia and the air-ground-ISR fight against JAM rocket capabilities. Important for the outcomes in

all three cases was the reality that the adversary was powerless against the attacker's fire system, except by avoiding detection.

In future offensive urban operations, the ability to strike at will from above MANPADS range with precision could be challenged; helicopter operations will almost certainly be contested at low altitudes. Furthermore, as the Grozny cases show, the ability to conduct counter-air and counterfire operations (against artillery and rockets) is imperative, as are measures to avoid detection. Against adversaries such as the Russians, if you can be seen, you can be targeted; if you can be targeted, you can be hit; if you can be hit, you will be killed. This is a challenge current members of the U.S. joint force have never faced in combat. A section from the *U.S. Army Combat Vehicle Modernization Strategy* on the Russian invasion of Ukraine illustrates the challenges presented by Russian capabilities:

In the aftermath of its annexation of Crimea in March 2014, Russian forces began supporting separatists in Eastern Ukraine with advanced weaponry, fire support, and special and conventional forces. This ongoing conflict offers important insights for the U.S. Army about the lethality of the modern battlefield; lethality the U.S. Army has not faced since World War II. Russian and separatist forces are employing combined arms warfare with advanced weapons to devastating effect. Russian artillery, particularly rocket launchers with conventional, thermobaric, and cluster munitions – using unmanned aerial systems (UAS), both for target location and battle damage assessment – is particularly effective against Ukrainian light armor and infantry formations. Additionally, the Russians are using their most advanced tanks in the Ukraine, including the T-72B3, T-80, and T-90. All of these tanks have 125mm guns capable of firing a wide range of ammunition, including antitank/anti-helicopter missiles with a six-kilometer range, and advanced armor protection, including active protection on some models. Finally, the Russian air defense systems (man-portable and vehicle mounted) have made it all but suicidal for the Ukrainian Air Force to provide air support to ground forces. Thus, the battlefields of Eastern Ukraine are similar to those envisioned by the U.S. Army during the Cold War, but with more mature technologies. It is a battlefield that requires

armor for maneuver. Light skinned vehicles, including BMP infantry fighting vehicles, have proven vulnerable to both artillery and tank fire. Dismounted infantry in defensive positions risks becoming fixed by fire and either isolated or overrun by maneuvering units supported by tanks. In short, the Ukrainian battlefield is a harbinger of the complex environment the U.S. Army will face in the future; a battlefield that requires mobile protected firepower, the integration of all arms, and counters to long-range artillery, UAS, air defenses, and tank protection systems.⁶

Exercise Mission Command

The very nature of urban operations creates complexities that demand rapid, low-level decisionmaking in both offensive and defensive operations. Perhaps the ultimate expression of this was in the first battle for Grozny, when Chechen rebels used small hunter-killer teams dispersed in ambush sites that restricted and canalized Russian maneuver. They took a heavy toll on Russian armor.⁷ Local support for the well-understood plan for the defense of Grozny was key, as it made it difficult for the Russians to mass forces or fires.⁸

Army defensive operations in urban terrain will likely face the same types of demands of widely dispersed, small-unit actions with a premium on initiative to defeat capable adversaries.

In the Battle of Sadr City, actions on the ground against JAM were decentralized, given the fleeting nature of the adversary. The rocket-hunting effort, however, was highly centralized given the demands to synchronize the efforts of a wide variety of assets.

⁶ David E. Johnson, "The Russian Invasion of Ukraine," in U.S. Army, *Combat Vehicle Modernization Strategy*, Fort Eustis, Va.: U.S. Army Training and Doctrine Command: Maneuver, Aviation, and Soldier Division, Army Capabilities Integration Center, September 2015, p. 15.

⁷ Lester W. Grau, "Russian-Manufactured Armored Vehicle Vulnerability in Urban Combat: The Chechnya Experience," *Red Star Thrust*, January 1997.

⁸ Johnson, Grissom, and Olikier, 2008, pp. 112.

Develop Capable Formations

The key challenge presented by urban operations is the intense demands it places on soldiers. As already noted, the Russians realized the final battle for Grozny that their soldiers had to be rotated in and out of combat to preserve their effectiveness. Furthermore, the defense formations may have to operate in smaller combined arms teams that will have to operate independently to seek and gain the initiative. There is also the need for reconnaissance and security formations to have the capability to fight for information. It is also very important for the Army to conduct combined arms operations at the lowest tactical level possible, and for those combined arms to be premised on mobile protected firepower. Finally, new technologies could improve the effectiveness of Army formations for both offensive and defensive urban operations. Several of these will be discussed in the next section.

Operations in Urban Areas: Implications for DOTMLPF-P

The case studies examined in this report reveal capability gaps across the DOTMLPF-P that the Army needs to understand and close to be able to become more effective in offensive and defensive urban operations. Many of these have been discussed in the section, above, on the Army Warfighting Challenges, but bear further elaboration.

Doctrine

As noted earlier, joint and Army doctrine manuals do not include case studies of operations in large urban areas, much less operations in megacities.⁹ Again, the CSA SSG and TRADOC are doing work to build the conceptual understanding for operations in megacities, but this has not yet manifested itself in doctrine. As historian I.B. Holley notes, there is considerable difference between a concept and doctrine:

⁹ There is mention of Army support to civil authorities during the turbulent Vietnam era and a vignette on the Los Angeles, California, riots in 1992, in FM 3-06, 2006.

Where a concept is a hypothesis – an inference that suggests that a proposed pattern of behavior may possibly lead to a desired result, a doctrine is a generalization based on sufficient evidence to suggest that a given pattern of behavior will probably lead to the desired result. Where a concept is tentative and speculative, a doctrine is more assured. . . . Perhaps the best definition holds doctrine as that mode of approach that repeated experience has shown usually works best.¹⁰

The key idea is that doctrine is experientially based, but the experience can be vicarious. We can learn from our own experiences and those of others. That is why the breadth of cases and observed solutions to the problems they presented is of paramount importance. Currently, the observations from many of the case studies in this report are only described in doctrinal manuals, rather than analyzed to distill generalizable lessons to apply to future operations. Ironically, the lessons from two of the most significant offensive urban operations in OIF, albeit not in megacities – Fallujah and Sadr City – have had virtually no influence on Army or joint doctrine. Finally, defensive urban operations receive little attention – in emerging concepts or doctrine – given the cultural preference of the U.S. joint force for offensive operations. Defensive urban operations, as already discussed, may be a key mission for the U.S. Army in countries on the periphery of Russia as the backbone of a viable deterrent. The battles for Grozny offer key insights for future Army concepts and doctrine in this regard.

Finally, training must recondition the Army for combat in which it may suffer mass casualties and in which large units will be at risk. Rarely since 9/11 has a platoon-sized formation been at risk of destruction.¹¹ In Ukraine, “two mechanized battalions were virtually wiped

¹⁰ I. B. Holley, Jr., *Technology and Military Doctrine: Essays on a Challenging Relationship*, Maxwell Air Force Base, Ala.: Air University Press, 2004, p. 21.

¹¹ See Randall Steeb, John Matsumura, Thomas J. Herbert, John Gordon, and William Horn, *Perspectives on the Battle of Wanat: Challenges of Small Unit Operations in Afghanistan*, Santa Monica, Calif.: RAND Corporation, OP-329/1-A, 2011. Two platoon-sized Combat Outposts in Afghanistan – COP Wanat and COP Keating – were almost overrun and had many casualties.

out with the combined effects of top-attack munitions and thermo-baric warheads."¹²

Organization

One of the key observations from the final battle for Grozny and the Battle of Sadr City is that the problems presented by each of these urban areas created demands for new organizations. In Grozny, the Russian organizational innovation was the storm units:

In their organization for combat, the Russians had learned lessons from both their own World War II experience and from their enemy. They set up attack ("storm") groups of 30 to 50 men and broke these groups into even smaller teams of a handful of men each. These smaller teams might include soldiers armed with an RPG, an automatic rifle, and a sniper rifle, and include two additional men armed with automatic weapons. Other storm group components included soldiers armed with Shmel flamethrowers, artillery and aviation forward observers, sappers, and reconnaissance personnel.¹³

The storm detachments were essentially the maneuver force that exploited the effects of fires.

The Chechen rebels also organized for the fight against the Russians, particularly in the first Grozny battle, employing decentralized hunter-killer teams armed with RPG-7 or RPG-18 shoulder-fired anti-tank rocket launchers to take on Russian formations in the channelized terrain in the city.¹⁴

In Sadr City, Colonel Hort's brigade contained only one of its organic maneuver battalions, the 1st Battalion, 68th Combined Arms Battalion, but had attached the 1st Squadron, Second Stryker Cavalry Regiment, and the 1st Battalion, 6th Infantry.¹⁵ His tactical opera-

¹² Karber, 2015, p. 17.

¹³ Johnson, Grissom, and Oliker, 2008, p. 235.

¹⁴ Johnson, Grissom, and Oliker, 2008, p. 244.

¹⁵ Johnson, Markel, and Shannon, 2013, p. 32.

tions center was also significantly augmented with liaison officers and technologies to enable him to execute the counter-rocket fight against JAM. In Colonel Hort's case, the counter-rocket capability was new to his formation, and his soldiers had to learn while doing.¹⁶ It took three to four days for the brigade to become fully effective in employing what were largely unprecedented capabilities for a brigade.¹⁷ These assets included "continuous support from two U.S. Air Force Predator UASs, at least one of which was armed; two Army Shadow UASs; six AH-64 Apache attack helicopters; Air Force fixed-wing CAS; and artillery, mainly GMLRS."¹⁸ Importantly, there was little counter-air threat to U.S. aviation assets.

Hort's innovations also relied on being able to plug into the significant infrastructure that was in place in Iraq when the battle began:

information from rapid aerostat initial deployment (RAID) sensors, counterfire radars, and other ISR assets. His battle staff was able to integrate this information and communicate it to operational units down to the company level via a number of relatively new technologies. For example, they used persistent surveillance and dissemination system of systems (PSDS2) to integrate the various sensors.¹⁹

The key organizational lesson from both Grozny battles and the Battle of Sadr City is that the problem presented by the adversary in the urban environment will force adaptation. The key question for the U.S. Army in the future is whether or not it has the appropriate organizational constructs for offensive and defensive operations in the cities where it might fight. Answering this question requires the situational understanding of the Army Warfighting Functions focused on the specific urban area and the capabilities of the adversary.

¹⁶ Johnson, Markel, and Shannon, 2013, p. 39.

¹⁷ Johnson, Markel, and Shannon, 2013, p. 53.

¹⁸ Johnson, Markel, and Shannon, 2013, p. 49.

¹⁹ Johnson, Markel, and Shannon, 2013, p. 51.

Training

The Army's guidance for training units is in ADRP 7-0:

Training is becoming more complex. Doing business as the Army has in the past is not an option. During the Cold War, the Army trained to a largely identified potential adversary using well-researched tactics. During the overseas contingency operations, the Army trained to a known adversary using largely emergent counterinsurgency tactics. The nature, scope, breadth, and depth of future conflict require that commanders train to produce adaptation and flexibility in forces and are decisively engaged in training management. Effective commanders use the same principles of mission command found in ADP 6-0 to build learning organizations and empower subordinates to develop and conduct training at the lowest possible echelons.²⁰

The cases examined in this report show that one can in fact know one's enemy and the urban terrain where they may be engaged. Focusing the Army Warfighting Challenges on the specific types of adversaries that could be faced in the future, their capabilities, and the joint force's capability gaps with these potential adversaries is a necessary first step in designing training (as well as other DOTMLPF-P gaps) to prepare the Army for the future. Indeed,

this discussion should be about how to create an army that requires minimal adaptation to respond to the conditions it finds itself in, because it has thought through and prepared for a broad range of possibilities. This broad preparation minimizes the need to adapt . . . is extremely important, because the costs of radical adaptation, as we saw in the early years of OIF, are blood, treasure, and strategic dislocation.²¹

²⁰ Army Doctrine Reference Publication 7-0, *Training Units and Developing Leaders*, Washington, D.C.: Headquarters, Department of the Army, 2012, p. 1-1.

²¹ David E. Johnson, "Failure to Learn: Reflections on a Career in the Post-Vietnam Army," *War on the Rocks*, January 24, 2014.

As noted earlier, a combination of leveraging the Army's Regionally Aligned Forces concept for achieving regional understanding and focusing intelligence and other analytical efforts on potential adversaries and urban conflict areas could indeed give the Army the understanding it believes it had about the Soviet Union in the Cold War for other adversaries and the urban areas in which it might have to fight. This approach will better enable the Army to develop training strategies that will help it to train as it will have to fight, rather than a general approach that emphasizes adaptation and flexibility. Again, it took Colonel Hort's brigade three to four days to adapt itself to the fight in Sadr City. This time to learn could be viewed as "impressively brief or dangerously slow time."²² Against more competent and capable adversaries than JAM, operating in complex urban terrain, it is probably dangerously slow, and training should minimize the adaptation time.

Many of the cases examined in this report show the importance of combined arms, particularly the infantry-armor team. These opportunities are constrained in the Army by the current stationing of forces – infantry and Stryker BCTs at posts without armor BCTs. This training is critical to prepare the Army for future urban operations, and it should be in offense and defense and against problems of subsurface and combat amidst multistory buildings.

The Army has developed training facilities that attempt to replicate urban operations, most notably at the U.S. Army Asymmetric Warfare Training Center at Fort A. P. Hill in Virginia and at its other training centers.²³ As earlier noted, these are useful for developing TTPs, but have limits because of their scale. This is an area for which simulations may show promise, particularly at the operational level.

Finally, the Army needs to understand the implications of the ongoing Russo-Ukrainian War and adapt its training for offensive and defensive operations against a threat similar to that posed by the Russians. This is an adversary the U.S. Army has not focused on since the end of the Cold War, and other potential adversaries (e.g., Hezbollah and the Islamic State) possess Russian stand-off fire capabilities

²² Johnson, Markel, and Shannon, 2013, p. 53.

²³ "U.S. Army Asymmetric Warfare Training Center," *CSPAN*, May 6, 2015.

(ATGMs, MANPADS, rockets). One of the key lessons from Ukraine is that

The one effective antidote to the increased lethality of the modern battlefield is the creation of prepared defenses. This includes multiple lines of entrenchments, the installation of covered firing positions and pillboxes and extensive use of preregistered defensive supporting artillery fire.²⁴

These skills have not been in high demand in the Army in a generation, and they need new doctrine, TTPs, and materiel solutions that must be incorporated into training.

Materiel

It is beyond the scope of this report to recommend specific materiel solutions to facilitate offensive and defensive urban operations. Below, we address several of the materiel gaps in current capabilities that the cases we have discussed show to be particularly important, and we suggest new capabilities and ideas that can enhance the effectiveness of urban operations. The first important question to ask about any materiel solution is what capability do they afford to fill a gap in urban operations that no current system adequately provides.

Active Protection

The first battle of Grozny showed the vulnerabilities of armored vehicles to fires from below, flanks, and above. The Russians were much more careful in their use of armor in the final battle for Grozny because of the vulnerabilities. On the other hand, the Battle of Sadr City demonstrated the value of tanks and Bradleys in defeating JAM. It is difficult to imagine adding sufficient armor for the 360-degree of combat vehicles, particularly against dual-shaped warheads that are proliferating around the world in the form of ATGMs and advanced RPGs. This is why the Russian Federation (and other countries, e.g., Israel) is fielding active protection systems. What operations in cities such as Grozny show is that active protection will have to solve more than horizontal

²⁴ Karber, 2015, p. 21.

direct fire challenges. It will have to address ATGM challenge from above. Such a capability could also have utility against other problems, e.g., top-attack and cluster munitions.

Direct Fire Weapons

Combat in Grozny revealed the elevation limitations of tank and infantry fighting vehicle weapons in dealing with targets at ground level (e.g., basement windows) or from upper floors of multistory buildings. The Russians used air defense gun systems that could hyper-elevate in Grozny (i.e., ZSU-23-4s and 2S6s), but they were thin-skinned and vulnerable and became the target of choice for Chechen hunter-killer teams. The Soviets and then the Russians began fielding “hyperelevating, rapid-firing, medium-caliber weapons with explosive ammunition for medium-armored vehicles – rather than modifying tanks.”²⁵ Examples include the BMP-3 and the BMD-4, which have turret mounted 100mm guns (which also fire anti-tank missiles) with coaxially mounted 30mm auto-cannons and a 7.62mm machinegun.²⁶

Indirect Fire Weapons

The U.S. Army has significant capability gaps in delivering area fires with the impending restrictions on using “cluster munitions.” State adversaries (and often their proxies) can present targeting dilemmas that demand area coverage at long range. This is particularly true with rockets and air defense systems. Russian multiple-launch rocket systems (MLRSs) have been particularly effective in Ukraine. For example, the 300mm 12-tube *Smerch* (Whirlwind) has a 90 kilometer range and can deliver a variety of antipersonnel and anti-armor munitions, including Dual-Purpose Improved Conventional Munitions (DPICM), scatterable mines, top-attack self-guided munitions, and thermobaric warheads.²⁷ These rockets can fire beyond the range

²⁵ Johnson, Grissom, and Oliker, 2008, p. 96.

²⁶ John Gordon IV, John Matsumura, Anthony Adler, Scott Boston, Matthew E. Boyer, Natasha Lander, and Todd Nichols, *Comparing U.S. Army Systems with Foreign Counterparts: Identifying Possible Capability Gaps and Insights from Other Armies*, Santa Monica: RAND Corporation, RR-716-A, 2014, p. 13.

²⁷ Karber, 2015, p. 16.

of U.S. Army counterfire radar detection and the means to shoot back at them, if they were located, is limited to the Army Tactical Missile System (ATACMS), and this capability is leaving the Army.

First, as a result of a 2007 fiscally based decision, the Army terminated the ATACMS program; inventories of both unitary and cluster munition warhead missiles are decreasing with time. Second, DoD policy on cluster munitions bans the use of noncompliant systems after December 31, 2018; this will further decrease long-range precision-fire (LRPF) inventories. DoD is pursuing studies to determine whether, when, and the quantity of Army LRPF systems and alternate (area effects) warheads will be developed and fielded.²⁸

The implications for Army forces defending an urban area is that they can be targeted and struck by long-range fires with no ability to conduct counterfire. This is the situation the Chechen rebels found themselves in during the final battle for Grozny, and they were defeated. Finally, the U.S. Army does not have large-caliber mortars or cannons with the capability to destroy buildings as can the Russian TOS-1 MLRS or 2S2 250mm self-propelled mortar. In the Battle of Sadr City, the Army occasionally employed Air Force-delivered precision bombs to take out buildings. Absent air supremacy in the early stages of an urban operation, this may not be an option and presents a capability gap.

Thermobaric Weapons

As already noted, the Russians made very effective use of thermobaric weapons in Afghanistan and Chechnya. The United States has used these types of weapons against caves in Afghanistan, and the USMC used the thermobaric Shoulder-Launched Multi-Purpose Assault Weapon—Novel Explosive (SMAW-NE) in Fallujah, where they were very effective.²⁹ For subterranean operations, e.g., tunnels and sewer systems, they may be useful for U.S. forces in the future. Again, the

²⁸ Army Capabilities Integration Center, Fires Division, "Capabilities Development for Long Range Precision Fires," May 16, 2014.

²⁹ GlobalSecurity.org, "Military: SMAW Novel Explosive (SMAW-NE)," 2016.

Russian military has fielded these types of warheads on infantry weapons and rocket launchers.

Counter-Air and Counter-UAS

In the early stages of a defensive urban operations in the Baltic cities, the Russian A2AD system could make achieving local air superiority, much less the air supremacy that U.S. forces have enjoyed in combat since World War II, problematic. This potential loss creates a gap in organic U.S. Army air defense capabilities and capacity against helicopters and fixed-wing aircraft. Furthermore, there is a new threat that US forces have not experienced. Russian forces have been integrating UASs into their artillery systems for observation and battle damage assessment as well as for other purposes. As Philip Karber notes from his observations of the Russo-Ukrainian War:

For U.S. and NATO forces that are used to having unilateral access to UAV technology the omnipresence of drones and the experience of real-time targeting by mass fires is likely to be a traumatic experience. From now on friendly forces ought to be exercising with opposing forces extensively utilizing drone technology and assuming they are under constant real-time surveillance.³⁰

Thus, there is a growing air defense capability gap that demands a materiel solution.

Robotics

The U.S. Army has used robotics in combat mainly in the counter-IED fight. There has also been ongoing discussion of other roles for these systems. There are, however, significant capabilities robotics could bring to urban operations:

- reconnaissance of high risk areas, e.g., interior rooms of buildings and subterranean areas
- economy of force efforts, e.g., robotic patrols in high risk and low threat areas

³⁰ Karber, 2015, p. 15.

- remote weapon stations in bunkers or mobile, unmanned platforms³¹
- unmanned ground engineering vehicles for battlefield demolition and construction; high threat clearance (obstacles, explosives, improvised explosive devices, unexploded ordnance, mines); explosive ordnance disposal; creating access and egress routes for combat personnel; demining; and disaster area support³²
- logistical resupply
- air or ground medical evacuation.

Finally, we recommend a close review of the “Final Report of the Maneuver and Mobility Concept Team,” from CSA SSG II, available at the General Officer Management Office restricted website, for the results of its year-long assessment of technologies that have great potential for urban as well as other types of operations.

Barriers

One of the key techniques employed in Baghdad during the Surge was the use of T-walls to isolate areas and prevent vehicle-borne IEDs from creating mass-casualty events. They were also used to shrink the problem by isolating areas, e.g., the Gold Wall in the Battle of Sadr City. Colonel Hort’s soldiers emplaced “3,000 12-foot-tall and 5-foot-wide reinforced concrete T-wall sections to create a 4.6-kilometer barrier”

³¹ See David Eshel, “Weaponized Sentry-Tech Towers Protecting Hot Borders,” *Aviation Week*, April 12, 2008. The Israelis have incorporated remote-controlled weapons systems (RCWSs) into static security locations. A good example is the Rafael Defense Systems Sentry-Tech pillbox towers located along the border with the Gaza Strip. These towers have mounted RCWSs that are linked to command centers that continuously monitor the border. Multiple towers can be controlled by a single operator and “one or more units can be used to engage the target following identification and verification by the commander. Enabling observers to employ synchronized firepower transformed the observation post into an integrated ‘sensor-and-shooter’ platform—capable of assuming some of the risky tasks previously done by rapid reaction forces and aerial attack platforms.” For a discussion of other types of technological innovation and its implication for future warfare, see Maryse Penny, Tess Hellgren, and Matt Bassford, *Future Technology Landscapes: Insights, Analysis, and Implications for Defense*, Santa Monica, Calif.: RAND Corporation, RR-478-MOD, 2013.

³² See Israel Aerospace Industries, “RAMTA Division,” 2002, which describes several Israeli unmanned ground vehicles and combat bulldozers.

over a 30-day period.³³ Colonel Billy Don Farris, the commander of 2nd Brigade Combat Team, 82nd Airborne Division, and Hort's predecessor, emplaced nearly 50 kilometers of T-walls. Again, this walling effort was critical in reducing destabilizing mass casualties, isolating the adversary, and shrinking the problem.

For an expeditionary Army, bringing forward the physical Class IV materials needed for such an effort is mind-boggling. Nevertheless, the capability to rapidly create and remove barriers could be a critical capability in offensive and defensive efforts and a materiel solution is needed for expeditionary Army forces.

Leader Development and Education

Developing solutions to the Army Warfighting Challenges and DOTMLPF-P capability gaps for future urban operations is the responsibility of Army leaders. We believe that these challenges are enduring and that the Army is not adequately prepared, as discussed, above. The Army's professional military education (PME) system has a central role in creating the intellectual basis for understanding these challenges and to guide learning. Rigorous case study analysis of past and future urban scenarios is a needed part of the curricula across the range of PME schools.

Furthermore, these institutions need to emphasize that the Army is truly facing a range of adversaries, from insurgents to capable state actors, that require different approaches. This will require a cultural change to embrace the defensive in some cases and a broadening appreciation of the capabilities of potential adversaries. The Army has garnered a great deal of combat experience since 9/11, but it has almost all been within context of fighting irregular adversaries with limited capabilities. The knowledge gained from these operations must be institutionalized, but the Army must also recognize that more competent and capable adversaries will require different approaches and capabilities.

³³ Johnson, Markel, and Shannon, p. xvii.

Personnel

Perhaps the greatest challenge in this area in the crucible of urban combat is the preservation of one's soldiers. Army Warfighting Challenge #9 – Improve Soldier, Leader and Team Performance – is important.³⁴ Nevertheless, the admonition of the Russian officer in the aftermath of Grozny is worth repeating again:

The psychological impact of high intensity urban combat is so intense that you should maintain a large reserve that will allow you to rotate units in and out of combat. If you do this, you can preserve a unit for a fairly long time. If you don't, once it gets used up, it can't be rebuilt. . . . Training and discipline are paramount. You can accomplish nothing without them. You may need to do the training in the combat zone. Discipline must be demanded. Once it begins to slip, the results are disastrous.³⁵

³⁴ See the "Learning Demands" for Army Warfighting Challenge #9:

1. Talent Management: How can the Army best recruit, assess, develop, and manage Soldiers and Army Civilians throughout their life cycle, with increased focus on individual competencies and attributes, to build effective teams and meet Army needs?
2. Human Performance Research and Assessment. How can the Army best continuously improve the cognitive, social, and physical performance of Army Professionals through the conduct and application of research, development, and assessment?
3. Holistic Health and Fitness. How can the Army best enhance Soldier and Army Civilian health and readiness through a personalized and holistic program that improves human performance and resilience?
4. Team Building. How can the Army best provide training guided by mission command to forge diverse individuals and organizations into cohesive teams based on mutual trust and unity of effort?
5. Social Intelligence. How can the Army best develop trusted professionals as effective team members, who thrive in complex social environments, adapt to diverse cultures, communicate effectively, and build relationships?
6. Army Profession. How does the Army reinforce an ethos of trust that supports honorable service, military expertise, stewardship, and esprit de corps?
7. Intellectual Optimization. How can the Army best develop innovative and individualized learning programs to equip Army Professionals with the intellectual diversity and capacity to succeed in complex environments?

³⁵ Quoted in Grau and Thomas, 2000.

Facilities

The joint force needs facilities that replicate the conditions of urban combat that it will face in the future, including defensive operations. These may, of necessity, be virtual facilities given the scale of urban areas. At the tactical level, however, it is important to provide physical facilities that place the relevant formation in a realistic approximation of the environment they may face, e.g., a battalion operation to clear a subway tunnel or prepare a strong point defense with interlocking trenches. In short, what function do you want a formation to master, and how can you provide sufficient facilities for them to train to the desired standard? At the operational and strategic levels, the facilities can be simulations or actual urban areas where commanders and staffs do staff rides and liaisons with local officials.

Policy

It is beyond the scope of this study to lay out all potential policy changes needed to close the Army's capability gaps for future urban operations. Two, however, need swift action.

First, the removal of cluster munitions, e.g., DPICM, from the Army could be disastrous against adversaries like Russia. After over a decade of restrictive ROE and fighting adversaries who were vulnerable to U.S. precision strike and ISR, the Army has a generation of soldiers and leaders who believe this is not only normal, but universal. The Battle of Fallujah is a distant memory or viewed as an exception, while the Battle of Sadr City seemed to prove the utility of precision. The other cases examined in this study show that ROE to prevent collateral damage is conditional on the actions of the adversary and, on a battlefield without air superiority, the U.S. ISR-strike complex may be compromised.

Second, the policy concerning the use of nonlethal technologies and autonomous systems is evolving (see the previously mentioned CSA SSG II report). The Army needs to understand which of these technologies help it cover capability gaps in urban and other operations and work to develop policies that enable their use.

Conclusion

In June 2014, the CSA SSG ominously concluded, “It is inevitable that at some point the United States Army will be asked to operate in a megacity [a city with a population of ten million or more inhabitants] and currently the Army is ill-prepared to do so.”³⁶ The first conclusion — that fighting in megacities is unavoidable — rests on a fairly straightforward set of assumptions. The world is becoming increasingly urbanized, and, while urbanization can be a potential boon for societies (indeed, the Director of National Intelligence estimates that urban centers will drive about 80 percent of the world economic growth in the future), its associated ills — poverty, disease, dislocation and others — can also drive instability.³⁷ As then the commander of U.S. Army Intelligence Center of Excellence Major General Robert Ashely remarked, “[In previous eras] you would not get bogged down and fight in urban areas. You are going to bypass those kinds of areas. But now it’s going to be potentially in those regions we are going to have to fight.”³⁸

The SSG’s more contentious claim — that the Army is ill-prepared to operate within these future urban environments — stems from a mismatch of current doctrine and the likely conditions within megacities. In the SSG’s analysis, the Army’s current doctrine assumes that the Army has “the ability to isolate and shape the urban environment and to utilize ground approaches from the periphery into the city.”³⁹ Thanks to the increasing size and scale of megacities combined with the declining size of the Army, it may not be able to rely on overwhelming force in the future, and so it — along with the rest of the U.S. national security apparatus — needs to rethink its approach to urban warfare.⁴⁰ For

³⁶ Marc Harris, Robert Dixon, Nicholas Melin, Daniel Hendrex, Richard Russo, and Michael Bailey, *Megacities and the United States: Army Preparing for a Complex and Uncertain Future*, Washington, D.C.: Chief of Staff of the Army, Strategic Studies Group, June 2014, p. 3.

³⁷ National Intelligence Council, 2012, p. v.

³⁸ Quoted in Hess, 2014.

³⁹ Harris et al., 2014, p. 3.

⁴⁰ Harris et al., 2014, p. 21; also see Bowers, 2015, p. 15.

some, the answer is “smarter” operations.⁴¹ After all, the Army does not need to isolate the entire city, just the adversary within it. And in many cases, combat in urban environments will require a careful balance of armored, mechanized forces to seek out and destroy the enemy while protecting U.S. forces and non-combatants from harm. To this point, Lieutenant General H.R. McMaster (et al.) recently commented that armored, mechanized infantry forces

have been invaluable on the battlefield. Thanks to their speed, protection, and firepower, along with their ability to work in concert with many other types of ground forces, armored forces have played crucial roles in defeating enemy militaries, toppling hostile regimes, fighting insurgents, and establishing security.

What this study has shown is that urban combat operations have historically been among the most arduous challenges an army can face. The increasing urbanization of the planet only seems to ensure that urban combat is in the Army’s future. The cases that we have looked at in detail in these pages reveal important gaps in the Army’s capabilities to succeed in urban combat and provides suggestions on how to address them. The first step forward, however, to realizing these capabilities is to understand and communicate the problem, both within and outside the Army, and to do the analysis and experimentation to determine what must be done. Adaptation in the moment, as attempted by the Russians in the first battle for Grozny, is not a formula for success.

⁴¹ For example, see Robert H. Scales, “Urban Warfare: A Soldier’s View,” *Military Review*, January–February 2005, pp. 11–12.

Lists of Figures and Tables

Figures

31.	Mogadishu Street Battle	26
32.	Urban Battlespace	29
33.	Baghdad Ethnic Breakdown in 2003.....	42
34.	Sadr City	47
35.	ISR and Strike Assets Employed in the Battle of Sadr City	49
41.	Operation Vigilant Resolve Concept of Operations	70
42.	Distribution of Forces North of Railroad Berm and Initial Assault Plan.....	74
43.	Fallujah Key Terrain	75
44.	Fallujah Map with Phase Lines Indicated.....	76
45.	RCT 1's Drive South, November 8-9	78
46.	RCT 7's Movements November 8-10, Pushing South to Phase Line Fran.....	79
47.	RCT 1's Drive South and West, November 9-10	80
48.	Casualties at Approximate Time of Day in Fallujah II	87
49.	Fallujah II Casualties over Time	88
410.	Officer and Enlisted Casualties in Fallujah II.....	89
411.	Fallujah II Casualties, by Situation Type.....	90
412.	Fallujah II Casualties, by Absence or Presence of Vehicle Type.....	91
413.	TF 2-2 Task Organization	109
414.	Scheme of Maneuver and Observation Plan for TF 2-2's BRT	112
415.	Fallujah II Casualties, by Weapon	115
416.	Fallujah II Casualties, by Unit	116

Tables

S.1. Comparing Methods to Shrink the Problem..... xiii
1.1. Megacities as of 201519
4.1. The Northern Assault Force Regimental Combat Teams 74
5.1. Comparing Methods to Shrink the Problem..... 122

Abbreviations

1-2 SCR	1st Squadron, 2nd Stryker Cavalry Regiment
2BCT	Second Brigade Combat Team
3-4 BCT	3rd Brigade Combat Team, 4th Infantry Division
3ID	Third Infantry Division
A2AD	anti-access and area denial
ASCOPE	area, structures, capabilities, organizations, people, and events
ATACMS	Army Tactical Missile System
ATGM	anti-tank guided missile
ATTP	Army Tactics, Techniques, and Procedures
BCT	brigade combat team
BMD-4	Boyevaya Mashina Desanta-4
BMP-3	Boyevaya Mashina Pyekhota-3
BRT	brigade reconnaissance team
C2	command and control
CAS	close air support
CCTV	closed circuit television
CONOP	concept of operations
CSA SSG	Chief of Staff Army, Strategic Studies Group
DoD	U.S. Department of Defense
DOTMLPF	doctrine, organization, training, materiel, leadership, personnel, and facilities

DPICM	Dual-Purpose Improved Conventional Munitions
EFP	explosively formed penetrator
ERA	explosive reactive armor
GMLRS	guided multiple-launch rocket system
HUMINT	human intelligence
IED	improvised explosive device
IFV	infantry fighting vehicle
IMINT	imagery intelligence
IO	information operations
IPB	intelligence preparation of the battlefield
ISF	Iraqi security forces
ISIS	Islamic State in Iraq and Syria
ISR	intelligence, surveillance, and reconnaissance
JAM	Jaish al-Mahdi
JDAM	Joint Direct Attack Munition
KIA	killed in action
LRAS	Long-Range Advanced Scout Surveillance System
LTC	lieutenant colonel (Army)
LtCol.	lieutenant colonel (Marine Corps)
LTG	lieutenant general (Army)
LtGen.	lieutenant general (Marine Corps)
MANPADS	man-portable air-defense system
MCLC	mine clearing line charge
MEF	Marine Expeditionary Force
MG	major general (Army)
MGen.	major general (Marine Corps)
MLRS	multiple launch rocket system
MND-B	Multi-National Division-Baghdad
MOUT	Military Operations on Urban Terrain
MSR	main supply route

NATO	North Atlantic Treaty Organization
OIF	Operation Iraqi Freedom
PL	phase line
RCT	Regimental Combat Team
ROE	rules of engagement
RPG	rocket-propelled grenade
SIGINT	signals intelligence
SOF	special operations forces
TF	task force
TRADOC	U.S. Army Training and Doctrine Command
TTP	tactics, techniques, and procedures
UAS	unmanned aerial system
UN	United Nations
USMC	U.S. Marine Corps

Bibliography

Ackerman, Elliot, "Relearning Storm Troop Tactics: The Battle of Fallujah," *Marine Corps Gazette*, September 2006.

Ackerman, Spencer, "Army's Fingerprint and Iris Database Heads for the Cloud," *Wired*, May 30, 2013. As of July 8, 2015:
<http://www.wired.com/2013/05/army-biometrics-cloud/>

— — —, "Snowden: NSA Accidentally Caused Syria's Internet Blackout in 2012," *The Guardian*, August 13, 2014. As of July 9, 2015:
<https://www.theguardian.com/world/2014/aug/13/snowden-nsa-syria-internet-outage-civil-war>

Ahmari, Sohrab, "An S.O.S. From Battleground Ukraine," *Wall Street Journal*, July 29, 2015.

Allard, Kenneth, *Somalia Operations: Lessons Learned*, Washington, D.C.: National Defense University Press, 1995. As of March 29, 2016:
http://www.dodccrp.org/files/Allard_Somalia.pdf

Army Capabilities Integration Center, *Army Warfighting Challenges*, Fort Eustis, Va., June 29, 2015. As of July 21, 2016:
http://www.arcic.army.mil/app_Documents/ARCIC_AUSA-Flyer_Army-Warfighting-Challenges_29JUNE15.pdf

— — —, *Learning Demands, for Army Warfighting Challenge #9*, Fort Eustis, Va., 2016. As of July 21, 2016:
<http://www.arcic.army.mil/Initiatives/army-warfighting-challenges.aspx>

Army Capabilities Integration Center, Fires Division, "Capabilities Development for Long Range Precision Fires," May 16, 2014.

Army Doctrine Reference Publication 2-0, *Intelligence*, Washington, D.C.: Headquarters, Department of the Army, August 31, 2012.

Army Doctrine Reference Publication 3-0, *Unified Land Operations*, Washington, D.C.: Headquarters, Department of the Army, May 16, 2012.

Army Doctrine Reference Publication 7-0, *Training Units and Developing Leaders*, Washington, D.C.: Headquarters, Department of the Army, 2012.

Army Tactics, Techniques, and Procedures 3-06.11, *Combined Arms Operations in Urban Terrain*, Washington, D.C.: Headquarters, Department of the Army, 2011.

Associated Press, "Somalia's Rivals Agree on a Truce," *Los Angeles Times*, February 15, 1992.

ADRP – See Army Doctrine Reference Publication.

ATTP – See Army Tactics, Techniques, and Procedures.

Avenger Company, 2nd Battalion, 63rd Armored Regiment, "Narrative of Combat Actions in Fallujah from 4 to 23 November 2004," Memorandum for Record, November 25, 2004, provided to RAND by Matt Matthews, June 4, 2015.

Bailey, Michael, Robert Dixon, Marc Harris, Daniel Hendrex, Nicholas Melin, and Richard Russo, "A Proposed Framework for Appreciating Megacities: A U.S. Army Perspective," *Small Wars Journal*, April 21, 2014. As of July 21, 2016: <http://smallwarsjournal.com/jrnl/art/a-proposed-framework-for-appreciating-megacities-a-us-army-perspective-0>

Bailey, Michael, and John D. Via, "Military Medical Implications of Future Megacity Operations," *Small Wars Journal*, February 13, 2015. As of July 21, 2016: <http://smallwarsjournal.com/jrnl/art/military-medical-implications-of-future-megacity-operations>

Barfi, Barak, "The Military Doctrine of the Islamic State: The Limits of Ba'athist Influence," *CTC Sentinel*, March 19, 2016.

Barrett, David, "One Surveillance Camera for Every 11 People In Britain, Says CCTV Survey," *The Telegraph*, July 10, 2013. As of July 7, 2015: <http://www.telegraph.co.uk/technology/10172298/One-surveillance-camera-for-every-11-people-in-Britain-says-CCTV-survey.html>

Batson, Douglas E., "Black Spots Are No Treasure Island: Land Tenure and Property Rights in Megacities," in Charles Ehlschlaeger, ed., *Understanding Megacities with the Reconnaissance, Surveillance, and Intelligence Paradigm*, Vicksburg, Miss.: U.S. Army Research and Development Center, April 2014. As of July 21, 2016: <http://kalevleetaru.com/Publish/Understanding-Megacities-Reconnaissance-Surveillance-Intelligence.pdf>

BBC, "Protesters Force Libya Internet Shutdown," *BBC News*, December 21, 2013. As of July 21, 2016: <http://www.bbc.com/news/world-africa-25481794>

— — —, "Ukraine Conflict: Many Soldiers Dead in 'Rocket Strike,'" *BBC News*, July 11, 2015. As of July 21, 2016: <http://www.bbc.com/news/world-europe-28261737>

— — —, “On This Day, 1943: Germans Surrender at Stalingrad,” February 2, 2016. As of March 28, 2016:
http://news.bbc.co.uk/onthisday/hi/dates/stories/february/2/newsid_3573000/3573003.stm

Bellavia, David, *House to House: An Epic Memoir of War*, New York: Pocket Star, 2008.

Bennett, Bruce, *Preparing for the Possibility of a North Korean Collapse*, Santa Monica, Calif.: RAND Corporation, RR-331-SRF, 2014. As of March 28, 2016:
http://www.rand.org/pubs/research_reports/RR331.html

Biometrics Institute, “Types of Biometrics,” 2015. As of August 11, 2015:
<http://www.biometricsinstitute.org/pages/types-of-biometrics.html>

Biometrics Task Force, “Biometric Automated Toolset (BAT) and Handheld Interagency Identity Detection Equipment (HIIDE),” September 19, 2007. As of July 8, 2015:
http://biometrics.nist.gov/cs_links/standard/archived/workshops/xmlandmobileid/Presentations-docs/Vermury-BAT-HIIDE.pdf

Boggiano, Chris, “A Co TF 2-2 Operation Phantom Fury,” email to Matt Matthews, July 18, 2006.

Boswood, Timothy Crowley, interview, October 21, 2005, provided to RAND by Matt Matthews.

Bowden, Mark, *Black Hawk Down: A Story of Modern War*, Berkeley, Calif.: Atlantic Monthly Press, 1999.

Bowers, Christopher O., “Future Megacity Operations – Lessons from Sadr City,” *Military Review*, May–June 2015.

Brooke, Chris, interview, in “Operational Leadership Experiences,” Combat Studies Institute, Fort Leavenworth, Kan., May 4, 2006. As of July 21, 2016:
<http://cgsc.contentdm.oclc.org/cdm/singleitem/collection/p4013coll13/id/200/rec/1>

Bumbaugh, Daniel, “Fallujah Study,” email to Matt Matthews, February 20, 2006.

Camp, Dick, *Operation Phantom Fury: The Assault and Capture of Fallujah, Iraq*, Minneapolis: Zenith Press, 2009.

Casey, Jr., George W., interview with the Contemporary Operations Study Team, Combat Studies Institute, Fort Leavenworth, Kan., February 5, 2008, p. 2.

Celestan, Gregory J., *Wounded Bear: The Ongoing Russian Military Operation in Chechnya*, Fort Leavenworth, Kan.: Foreign Military Studies Office Publications, August 1996. As of November 16, 2015:
<http://fms.leavenworth.army.mil/documents/wounded/wounded.htm#46>

Chandrasekaran, Rajiv, "Key General Criticizes April Attack in Fallujah: Abrupt Withdrawal Called Vacillation," *Washington Post*, September 13, 2004.

Chun, Clayton, *Gothic Serpent: Black Hawk Down Mogadishu 1993*, Oxford, UK: Osprey Publishing, 2012.

Clausewitz, Carl von, *Principles of War*, ed., trans., Hans W. Gatzke, Harrisburg, Pa.: The Military Service Publishing Company, 1942; reprint, Mineola, N.Y.: Dover Publications, 2003.

Coffey, Michael, "Military Learning Between the Chechen Wars," *Journal of Russian and Asian Studies*, October 24, 2006:

http://www.sras.org/military_learning_between_the_chechen_wars

Cohen, Noam, "Egyptians Were Unplugged, and Uncowed," *New York Times*, February 20, 2011.

Command Chronology for 1/3 Marines, July–December 2004, provided to RAND by Matt Matthews, June 18, 2015.

Command Chronology for 3rd LAR Battalion, October–November 2004, provided to RAND by Matt Matthews, June 6, 2015.

Command Chronology for Regimental Combat Team 7, July–December 2004, provided to RAND by Matt Matthews, June 18, 2015.

Congressional Budget Office, *Long-Term Implications of the 2015 Future Years Defense Program*, Washington, D.C., November 2014. As of March 29, 2016: <http://www.cbo.gov/sites/default/files/cbofiles/attachments/49483-FDYP.pdf>

Cordova, Amado, Lindsay D. Millard, Lance Menthe, Robert A. Guffey, and Carl Rhodes, *Motion Imagery Processing and Exploitation (MIPE)*, Santa Monica, Calif.: RAND Corporation, RR-154-AF, 2013. As of July 13, 2015:

http://www.rand.org/pubs/research_reports/RR154.html

DiMarco, Louis A., *Concrete Hell: Urban Warfare from Stalingrad to Iraq*, London: Osprey Publishing, 2012.

Doughty, Robert A., *The Evolution of U.S. Army Tactical Doctrine: 1946–76*, Fort Leavenworth, Kan.: U.S. Army Command and General Staff College Press, 1979.

Elson, Sara Beth, Douglas Yeung, Parisa Roshan, S. R. Bohandy, and Alireza Nader, *Using Social Media to Gauge Iranian Public Opinion and Mood After the 2009 Election*, Santa Monica, Calif.: RAND Corporation, TR-1161-RC, 2012. As of March 29, 2016:

http://www.rand.org/pubs/technical_reports/TR1161.html

Eshel, David, "Weaponized Sentry-Tech Towers Protecting Hot Borders," *Aviation Week*, April 12, 2008.

Estes, Kenneth W., *U.S. Marines in Iraq, 2004–2005: Into the Fray: Marines in the Global War on Terrorism*, Washington D.C.: U.S. Marine Corps Historical Division, 2011.

F Troop, 4th Cavalry, 3BCT Brigade Reconnaissance Troop, "Operation Phantom Fury History of Events," provided to RAND by Matt Matthews, June 6, 2015.

Fair, C. Christine, *Military Operations in Urban Areas: The Indian Experience*, Santa Monica, Calif.: RAND Corporation, RP-1063, 2003.

— — —, *Urban Battlefields of South Asia: Lessons Learned from Sri Lanka, India, and Pakistan*, Santa Monica, Calif.: RAND Corporation, MG-210-A, 2004. As of July 21, 2016:

<http://www.rand.org/pubs/monographs/MG210.html>

Fairness and Accuracy in Reporting, "CNN to Al Jazeera: Why Report Civilian Deaths?" April 15, 2004. March 29, 2016:

<http://fair.org/take-action/action-alerts/cnn-to-al-jazeera-why-report-civilian-deaths/>

Felix, Kevin M., and Frederick D. Wong, "The Case for Megacities," *Parameters*, Vol. 45, No. 1, Spring 2015.

Field Manual 3-06, *Urban Operations*, Washington, D.C.: Headquarters, Department of the Army, October 2006.

Fisher, Ian, "U.S. Troops Fire on Iraqi Protesters, Leaving 15 Dead," *New York Times*, April 29, 2003.

FM — See Field Manual.

Fontenot, Gregory, E.J. Degen, and David Tohn, *On Point: The United States Army in Operation Iraqi Freedom*, Annapolis, Md.: Naval Institute Press, 2005.

Formica, Michael D., U.S. Army Colonel, interview with Archives Iraqi OIF Study Group, December 13, 2004.

Freedberg, Syndey, "Russian Drone Threat: Army Seeks Ukraine Lessons," *Breaking Defense*, October 14, 2015. As of March 29, 2016:

<http://breakingdefense.com/2015/10/russian-drone-threat-army-seeks-ukraine-lessons/>

Galeotti, Mark, *Russia's Wars in Chechnya 1994–2009*, Oxford, UK: Osprey Publishing, 2014.

GlobalSecurity.org, "Military: SMAW Novel Explosive (SMAW-NE)," 2016. As of July 21, 2016:

<http://www.globalsecurity.org/military/systems/ground/smaw-ne.htm>

Gordon IV, John, John Matsumura, Anthony Adler, Scott Boston, Matthew E. Boyer, Natasha Lander, and Todd Nichols, *Comparing U.S. Army Systems with Foreign Counterparts: Identifying Possible Capability Gaps and Insights from Other Armies*, Santa Monica, Calif.: RAND Corporation, RR-716-A, 2014. As of July 21, 2016:

http://www.rand.org/pubs/research_reports/RR716.html

Gordon, Michael, "Details of U.S. Raid in Somalia: Success So Near, a Loss So Deep," *New York Times*, October 25, 1993.

— — —, "U.S. Begins Erecting Wall in Sadr City," *New York Times*, April 18, 2008.

Gordon, Michael, with Douglas Jehl, "After the War: Militants; Foreign Fighters Add to Resistance in Iraq, U.S. Says," *New York Times*, June 22, 2003.

Gott, Kendall D., ed., *Eyewitness to War: The U.S. Army in Operation AL FAJR: An Oral History*, Volumes I and II, Fort Leavenworth, Kan.: Combat Studies Institute Press, 2006.

Gouré, Daniel, "Why Is the Army Planning to Fight in Megacities?" Lexington Institute, May 14, 2014. As of July 21, 2016:

<http://lexingtoninstitute.org/why-is-the-army-planning-to-fight-in-megacities/>

Grau, Lester, "The High-Precision Tulip: Development and Combat Employment of the Soviet Laser-Guided Mortar Round," no date. As of July 21, 2016:

<http://fmso.leavenworth.army.mil/documents/High-precision-tulip.pdf>

— — —, "Russian Urban Tactics: Lessons from the Battle for Grozny," *Strategic Forum*, No. 38, July 1995.

— — —, "Russian-Manufactured Armored Vehicle Vulnerability in Urban Combat: The Chechnya Experience," *Red Star Thrust*, January 1997. As of July 21, 2016:

<http://fas.org/man/dod-101/sys/land/row/rusav.htm>

— — —, "Underground Combat: Stereophonic Blasting, Tunnel Rats and the Soviet-Afghan War," *Engineer*, November 1998.

— — —, "Preserving Shock Action: A New Approach to Armored Maneuver Warfare," *Armor*, 2006.

Grau, Lester W., and Timothy Smith, "A 'Crushing' Victory: Fuel-Air Explosives and Grozny 2000," *Marine Corps Gazette*, 2000. As of July 21, 2016:

<http://fmso.leavenworth.army.mil/documents/fuelair/fuelair.htm>

Grau, Lester W., and Timothy L. Thomas, "Russian Lessons Learned from the Battles for Grozny," *Marine Corps Gazette*, 2000. As of November 16, 2015:

http://fmso.leavenworth.army.mil/documents/Rusn_leslrn.htm

Gross, Doug, "Syria Caused Internet Blackout, Security Firm Says," *CNN*, December 3, 2012. As of July 9, 2015:

<http://www.cnn.com/2012/11/30/tech/web/syria-Internet/>

Harris, Marc, Robert Dixon, Nicholas Melin, Daniel Hendrex, Richard Russo, and Michael Bailey, *Megacities and the United States Army: Preparing for a Complex and Uncertain Future*, Washington, D.C.: Chief of Staff of the Army, Strategic Studies Group, June 2014. As of July 21, 2016:

https://www.army.mil/article/128636/Megacities_and_the_United_States_Army__Preparing_for_a_complex_and_uncertain_future

Harris, Shane, "How the NSA Became a Killing Machine," *The Daily Beast*, November 11, 2014. As of June 12, 2015:

<http://www.thedailybeast.com/articles/2014/11/09/how-the-nsa-sorta-won-the-last-iraq-war.html>

Helms, Nathaniel, *My Men Are My Heroes: The Brad Kasal Story*, Washington, D.C.: Naval Institute Press, 2007.

Herrera, Ricardo, "Brave Rifles at Tall Afar, September 2005," in William G. Robertson, ed., *In Contact! Case Studies from the Long War*, Fort Leavenworth, Kan.: Combat Studies Institute Press, 2006.

Hess, Bill, "Army Intelligence Looking to Combat Future Enemies: Conference Begins Today on Fort," *Sierra Vista Herald*, December 7, 2014. As of June 29, 2015:

<http://svherald.com/content/bill-hess/2014/12/07/392516>

Holley, Jr., I. B., *Technology and Military Doctrine: Essays on a Challenging Relationship*, Maxwell Air Force Base, Ala.: Air University Press, 2004.

Howard, Philip N., Aiden Duffy, Deen Freelon, Muzammil Hussain, Will Mari, and Marwa Mazaid, "Opening Closed Regimes: What Was the Role of Social Media During the Arab Spring?" *Project on Information Technology and Political Islam*, working paper, 2011. As of July 9, 2015:

http://pitpi.org/wp-content/uploads/2013/02/2011_Howard-Duffy-Freelon-Hussain-Mari-Mazaid_pITPI.pdf

Huggler, Justin, "Putin 'Privately Threatened to Invade Poland, Romania and the Baltic States,'" *The Telegraph*, September 18, 2014. As of March 29, 2016:

<http://www.telegraph.co.uk/news/worldnews/europe/russia/11106195/Putin-privately-threatened-to-invade-Poland-Romania-and-the-Baltic-states.html>

Iannotta, Ben, "Biometrics: A New Intelligence Discipline," *Defense News*, May 13, 2013. As of July 8, 2015:

<http://archive.defensenews.com/article/20130513/C4ISR01/305130017/Biometrics-New-Intelligence-Discipline>

International Crisis Group, *Iraq's Civil War, the Sadrists and the Surge*, Middle East Report No. 72, February 7, 2008.

Israel Aerospace Industries, "RAMTA Division," 2002. As of July 21, 2016:

http://www.iai.co.il/32772-en/Groups_Commercial_Aircraft_RAMTA.aspx

Jenzen-Jones, N. R., and Jonathan Ferguson, "An Examination of Arms & Munitions in the Ongoing Conflict in Ukraine," *Armament Research Services*, No. 3, 2014.

Johnson, David E., *Hard Fighting: Israel in Lebanon and Gaza*, Santa Monica, Calif.: RAND Corporation, MG-1085-A/AF, 2011. As of March 29, 2016: <http://www.rand.org/pubs/monographs/MG1085.html>

— — —, "Failure to Learn: Reflections on a Career in the Post-Vietnam Army," *War on the Rocks*, January 24, 2014. As of November 16, 2015:

<http://warontherocks.com/2014/01/>

failure-to-learn-reflections-on-a-career-in-the-post-vietnam-army/

— — —, "Fighting the 'Islamic State' The Case for U.S. Ground Forces," *Parameters*, Vol. 45, No. 1, Spring 2015a, pp. 7-17.

— — —, "Means Matter: Competent Ground Forces and the Fight Against ISIL," *War on the Rocks*, March 19, 2015b. As of March 28, 2016:

<http://warontherocks.com/2015/03/>

means-matter-competent-ground-forces-and-the-fight-against-isil/

— — —, "The Russian Invasion of Ukraine," in U.S. Army, *Combat Vehicle Modernization Strategy*, Fort Eustis, Va.: U.S. Army Training and Doctrine Command: Maneuver, Aviation, and Soldier Division, Army Capabilities Integration Center, September 2015c, p. 15. As of July 21, 2016:

<http://ec.militarytimes.com/static/pdfs/Master-CVMS-1300-01-SEP-2015.pdf>

Johnson, David E., Adam R. Grissom, and Olga Oliker, *In the Middle of the Fight: An Assessment of Medium-Armored Forces in Past Military Operations*, Santa Monica, Calif.: RAND Corporation, MG-709-A, 2008. As of March 28, 2016: <http://www.rand.org/pubs/monographs/MG709.html>

Johnson, David E., M. Wade Markel, and Brian Shannon, *The 2008 Battle of Sadr City: Reimagining Urban Combat*, Santa Monica, Calif.: RAND Corporation, RR-160-A, 2013. As of March 29, 2016:

http://www.rand.org/pubs/research_reports/RR160.html

Joint Publication 3-06, *Joint Urban Operations*, Washington, D.C.: Joint Chiefs of Staff, November 20, 2013.

Kahl, Colin H., "In the Crossfire or the Crosshairs? Norms, Civilian Casualties, and U.S. Conduct in Iraq," *International Security*, Vol. 32, No. 1, Summer 2007.

Karber, Phillip A., "Lessons Learned from the Russo-Ukrainian War: Personal Observations," The Potomac Foundation, July 2015.

Keegan, John, *The Face of Battle*, New York: Viking Press, 1976.

Keiler, Jonathan F., *Who Won the Battle of Fallujah?* Washington, D.C.: U.S. Naval Institute Press, January 2005. As of March 29, 2016:

http://www.military.com/NewContent/1,13190,NI_0105_Fallujah-P1,00.html

Kelly, Terrence K., "Stop Putin's Next Invasion Before It Starts," *U.S. News and World Report*, March 20, 2015.

Kilcullen, David, *Out of the Mountains: The Coming Age of the Urban Guerrilla*, Oxford, UK: Oxford University Press, 2013.

Knarr, William, Robert Castro, and Dianne Fuller, *The Battle for Fallujah Al Fajr – the Myth-Buster*, IDA Paper P-4455, Arlington, Va.: Institute for Defense Analysis, 2009.

Knights, Michael, "No Go No More: The Battle for Sadr City," *Jane's Intelligence Review*, Vol. 20, No. 7, July 2008.

Larson, Eric V., and Bogdan Savych, *Misfortunes of War: Press and Public Reactions to Civilian Deaths in Wartime*, Santa Monica, Calif.: RAND Corporation, MG-441-AF, 2007. As of March 29, 2016:

<http://www.rand.org/pubs/monographs/MG441.html>

Laurence, Peter, "Ukraine 'Can't Stop Russian Armour,'" *BBC News*, February 6, 2015. As of March 29, 2016:

<http://www.bbc.com/news/world-europe-31164822>

Leetaru, Kalev H., and Charles R. Ehlschlaeger, "Modeling the Discourse of Megacities: Assessing Remote Populations in the Non-Western Worlds," in Charles R. Ehlschlaeger, ed., *Understanding Megacities with the Reconnaissance, Surveillance, and Intelligence Paradigm*, Vicksburg, Miss.: U.S. Army Research and Development Center, April 2014, pp. 76–83.

Leichman, Abigail Klein, "Israel's Top 12 Video Surveillance Advances," *Israel21c*, April 23, 2013. As of August 11, 2015:

<http://www.israel21c.org/israels-top-12-video-surveillance-advances/>

Les fantômes furieux de Falloujah: Opération al-Fajr/Phantom Fury, Cahier du retex, Paris, Centre de Doctrine d'Emploi des Forces, Division Recherche et Retour d'Expérience, 2006.

de Lira, Gerald, *The Anger of a Great Nation: Operation Vigilant Resolve*, Quantico, Va.: U.S. Marine Corps Command and Staff College, 2009.

Livingston, Gary, *Fallujah with Honor: First Battalion, Eight Marine's Role in Operation Phantom Fury*, New York: Caisson Press, 2005.

Lofland, Valerie J., *Somalia: U.S. Intervention and Operation Restore Hope*, Maxwell Air Force Base, Ala.: The Air University, 2002. As of March 28, 2016:

<http://www.au.af.mil/au/awc/awcgate/navy/pmi/somalia1.pdf>

Lowry, Richard S., *New Dawn: The Battles for Fallujah*, El Dorado Hills, Calif.: Savas Beatie, 2010.

Lubold, Gordon, and Shane Harris, "Exclusive: Pentagon Withholds Internal Report About Flawed \$2.7 Billion Intel Program," *Foreign Policy*, March 18, 2014.

Ludwig, Konrad R.K., *Stryker: The Siege of Sadr City*, La Cañada Flintridge, Calif.: Roland-Kjos, 2011.

Lyons, Lawrence, and Ahmed I. Samatar, *State Collapse, Multilateral Intervention, and Strategies for Political Reconstruction*, Washington, D.C.: Brookings Institution Press, 1995.

Magnuson, Stew, "Army Wants to Make 'Every Soldier a Sensor,'" *National Defense Magazine*, May 2007. As of July 1, 2015:

<http://www.nationaldefensemagazine.org/archive/2007/May/Pages/ArmyWantSensor2650.aspx?PF=1>

Mansoor, Peter R., *Baghdad at Sunrise: A Brigade Commander's War in Iraq*, New Haven, Conn.: Yale University Press, 2008.

— — —, *Surge: My Journey with General David Petraeus and the Remaking of the Iraq War*, New Haven, Conn.: Yale University Press, 2013.

Manual for the Operation of the Joint Capabilities Integration and Development System (JCIDS), February 12, 2015. As of February 12, 2015:

https://dap.dau.mil/policy/Documents/2015/JCIDS_Manual_with_errata_through_20151218.pdf

Marine Corps Warfighting Publication 3-35.3, *Military Operations in Urban Terrain (MOUT)*, Washington, D.C.: Headquarters U.S. Marine Corps, April 26, 1998. As of July 21, 2016:

<http://www.marines.mil/Portals/59/MCWP%203-35.3.pdf>

Matthews, Matt M., ed., *Operation Al Fajr (Phantom Fury): Fallujah 2004*, Fort Leavenworth, Kan.: U.S. Army Combined Arms Center, 2015. As of March 29, 2016:

http://usacac.army.mil/cac2/cgsc/carl/download/csipubs/matthews_fajr.pdf

McChrystal, Stanley A., *My Share of the Task*, New York: Penguin, 2014.

McKinley, Chris, Mark Elfendahl, and H. R. McMaster, "Why the U.S. Army Needs Armor," *Foreign Affairs*, May–June 2013.

McWilliams, Timothy S., and Nicholas J. Schlosser, *U.S. Marines in Battle: Fallujah, November–December 2004*, Quantico, Va.: U.S. Marine Corps History Division, 2014.

Medby, Jamison Jo, and Russell W. Glenn, *Street Smart: Intelligence Preparation of the Battlefield for Urban Operations*, Santa Monica, Calif.: RAND Corporation, MR-1287-A, 2002. As of July 21, 2016

http://www.rand.org/pubs/monograph_reports/MR1287.html

Metz, Thomas, interview, Archives Iraqi OIF Study Group, April 7, 2014.

Metz, Thomas, and James Hutton, "Massing Effects In the Information Domain: A Case Study in Aggressive Information Operations," *Military Review*, May–June 2006, pp. 2–12.

"Mission to Somalia; Transcript of President's Address on Somalia," *New York Times*, December 5, 1992.

National Intelligence Council, *Global Trends 2010*, Washington, D.C.: Office of the Director of National Intelligence, 1997. As of March 28, 2016:
<http://www.dni.gov/index.php/about/organization/national-intelligence-council-global-trends/global-trends-2010>

— — —, *Global Trends 2030: Alternative Worlds*, Washington, D.C.: Office of the Director of National Intelligence, 2012. As of July 21, 2016:
<http://www.dni.gov/index.php/about/organization/global-trends-2030>

Natonski, Richard, interview, in "Operational Leadership Experiences," Combat Studies Institute, Fort Leavenworth, Kan., April 9, 2007.

— — —, interview, *The Army Archives*, April 3, 2008, provided to RAND by Matt Matthews, June 18, 2015.

Newell, Peter A., interview, in "Operational Leadership Experiences," Combat Studies Institute, Fort Leavenworth, Kan., March 26, 2006.

— — —, "Memorandum for Record, Task Force 2nd Battalion, 2 Infantry, Operation Phantom Fury," January 2, 2005, provided to RAND by Matt Matthews.

Nicholson, Lawrence D., interview with Archives Iraqi OIF Study Group, January 18, 2005.

O'Donnell, Patrick K., *We Were One: Shoulder to Shoulder with the Marines Who Took Fallujah*, Philadelphia, Pa.: Da Capo Press, 2006.

Odierno, Raymond T., "Regionally Aligned Forces: A New Model for Building Partnerships," *Army Live – The Official Blog of the United States Army*, March 22, 2012. As of July 21, 2016:
<http://armylive.dodlive.mil/index.php/2012/03/aligned-forces/>

Oliker, Olga, *Russia's Chechen Wars 1994–2000: Lessons from Urban Combat*, Santa Monica, Calif.: RAND Corporation, MR-1289-A, 2001. As of March 29, 2016:
http://www.rand.org/pubs/monograph_reports/MR1289.html

Oliker, Olga, Michael J. McNerney, and Lynn E. Davis, *NATO Needs a Comprehensive Strategy for Russia*, Santa Monica, Calif.: RAND, PE-143-OSD, 2015. As of July 21, 2016:
<http://www.rand.org/pubs/perspectives/PE143.html>

Parfitt, Tom, "Ukraine Promises 'Retribution' as at Least 19 Soldiers Killed in Rebel Rocket Attack," *The Telegraph*, July 11, 2014. As of July 21, 2016:
<http://www.telegraph.co.uk/news/worldnews/europe/ukraine/10962359/Ukraine-promises-retribution-as-at-least-19-soldiers-killed-in-rebel-rocket-attack.html>

Penhaul, Karl, Jane Arraf, Jamie McIntyre, Bessem Muhy, Cal Perry, Kevin Flower, and Mohammed Tawfeeq, "Battle for Falluja Under Way: U.S., Iraqi Troops Launch Offensive to Oust Insurgents," *CNN*, November 9, 2004. As of July 21, 2016:

<http://www.cnn.com/2004/WORLD/meast/11/08/iraq.main/>

Penny, Maryse, Tess Hellgren, and Matt Bassford, *Future Technology Landscapes: Insights, Analysis, and Implications for Defense*, Santa Monica, Calif.: RAND Corporation, RR-478-MOD, 2013. As of July 25, 2016:

http://www.rand.org/pubs/research_reports/RR478.html

Perkins, David, interview with RAND staff on July 21, 2015.

Petho, Andras, David S. Fallis and Dan Keating, "ShotSpotter Detection System Documents 39,000 Shooting Incidents in the District," *Washington Post*, November 2, 2013.

Petraeus, David H., "CENTCOM Update, Center for a New American Security," briefing, 2009.

Pincus, Walter, "An Intelligence Gap Hinders U.S. in Iraq," *Washington Post*, December 24, 2004. As of July 10, 2015:

<http://www.washingtonpost.com/wp-dyn/articles/A23204-2004Dec23.html>

Pirnie, Bruce R., and Edward O'Connell, *Counterinsurgency in Iraq (2003-2006): RAND Counterinsurgency Study – Volume 2*, Santa Monica, Calif.: RAND Corporation, MG-595/3-OSD, 2008. As of March 29, 2016:

<http://www.rand.org/pubs/monographs/MG595z3.html>

Priest, Dana, "NSA Growth Fueled by Need to Target Terrorists," *Washington Post*, July 21, 2013. As of July 10, 2015:

https://www.washingtonpost.com/world/national-security/nsa-growth-fueled-by-need-to-target-terrorists/2013/07/21/24c93cf4-f0b1-11e2-bed3-b9b6fe264871_story.html

Public Broadcasting Service, "Ambush in Mogadishu: Interview General Thomas Montgomery (Ret)," *Frontline*, 2014. As of July 21, 2016:

<http://www.pbs.org/wgbh/pages/frontline/shows/ambush/interviews/montgomery.html>

— — —, "Private Warriors: Contractors: The High-Risk Contracting Business," *Frontline*, June 2015. As of March 29, 2016:

<http://www.pbs.org/wgbh/pages/frontline/shows/warriors/contractors/highrisk.html>

Rainey, Jim, U.S. Army LTC, interview, in "Operational Leadership Experiences," Combat Studies Institute, Fort Leavenworth Kan., April 26, 2006.

Rechkalov, Vadim, "Why the Special Services Cannot Catch Shamil Basayev. Reason No 5: Basayev's Ideology," *Izvestiya*, 2004, quoted in Timothy L. Thomas, "Russian Tactical Lessons Learned Fighting Chechen Separatists," 2005, p. 5. As of July 21, 2016:

<http://fmso.leavenworth.army.mil/documents/CHECHENTACTICS.pdf>

Ricks, Thomas, *Fiasco: The American Military Adventure in Iraq*, New York: Penguin Books, 2006.

Russell, James, *Innovation, Transformation, and War: Counterinsurgency Operations in Anbar and Ninewa Provinces, Iraq, 2005–2007*, Stanford, Calif.: Stanford University Press, 2011.

Russo, Richard, "The Gotham Division and Staff Sergeant Parker: Imagining the Future of Urban Warfare," June 12, 2014. As of March 28, 2016:

<http://www.scribd.com/doc/229302631/Gotham-Division>

Scales, Robert H., "Urban Warfare: A Soldier's View," *Military Review*, January–February 2005.

Segell, Glen M., "Terrorism on London Public Transport," *Defense & Security Analysis*, Vol. 22, No. 1, March 2006.

Shachtman, Noah, "Army Tracking Plan: Drones That Never Forget a Face," *Wired*, September 28, 2011. As of July 8, 2015:

<http://www.wired.com/2011/09/drones-never-forget-a-face/>

Shapiro, Jacob N., and Nils B. Weidmann, "Is the Phone Mightier Than the Sword? Cellphones and Insurgent Violence in Iraq," *International Organization*, Vol. 69, No. 2, Spring 2015.

Shih, Gerry, "China's Draft Cybersecurity Law Could Up Censorship, Irk Business," *Reuters*, July 8, 2015. As of July 9, 2015:

<http://www.reuters.com/article/2015/07/08/us-china-cybersecurity-idUSKCN0PI09020150708>

Shlapak, David A., and Michael Johnson, *Reinforcing Deterrence on NATO's Eastern Flank: Wargaming the Defense of the Baltics*, Santa Monica, Calif.: RAND Corporation, RR-1253-A, 2016. As of July 25, 2016:

http://www.rand.org/pubs/research_reports/RR1253.html

Starr, Michelle, "Facial Recognition App Matches Strangers to Online Profiles," *CNET*, January 7, 2014. As of August 11, 2015:

<http://www.cnet.com/news/facial-recognition-app-matches-strangers-to-online-profiles/>

Statista, "Number of Social Network Users Worldwide from 2010 to 2018 (in Billions)," 2015. As of July 8, 2015:

<http://www.statista.com/statistics/278414/number-of-worldwide-social-network-users/>

Steeb, Randall, John Matsumura, Thomas J. Herbert, John Gordon, and William Horn, *Perspectives on the Battle of Wanat: Challenges of Small Unit Operations in Afghanistan*, Santa Monica, Calif.: RAND Corporation, OP-329/1-A, 2011. As of July 21, 2016:

http://www.rand.org/pubs/occasional_papers/OP329z1.html

Stewart, Richard W., *United States Forces, Somalia, After Action Report and Historical Overview: The United States Army in Somalia, 1992–1994*, Washington, D.C.: U.S. Army, Center of Military History, 2003. As of July 21, 2016:

<http://www.history.army.mil/html/documents/somalia/SomaliaAAR.pdf>

Stout, Kristie Lu, “China’s Great Firewall: Fortune at the Expense of Freedom?” *CNN*, March 25, 2015. As of March 29, 2016:

<http://www.cnn.com/2015/03/25/asia/china-Internet-censorship-kristie-lu-stout/>

“Task Force 2-2 Spot Reports,” provided to RAND by Matt Matthews, June 5, 2015.

Tawfeeq, Mohammed, and Jomana Karadsheh, “Cease-Fire Reached in Baghdad’s Sadr City,” *CNN*, May 11, 2008. As of March 29, 2016:

<http://www.cnn.com/2008/WORLD/meast/05/10/iraq.main/>

“The Economist Explains: How Does China Censor the Internet?” *The Economist*, April 21, 2013. As of July 21, 2016:

<http://www.economist.com/blogs/economist-explains/2013/04/economist-explains-how-china-censors-Internet>

“The Gulf/2000 Project,” New York: The School of International and Public Affairs of Columbia University. As of June 15, 2015:

<http://gulf2000.columbia.edu/maps.shtml>

Thomas, Timothy L., “Grozny 2000: Urban Combat Lessons,” *Military Review*, 2000. As of July 21, 2016:

<http://fmso.leavenworth.army.mil/documents/grozny2000/grozny2000.htm>

— — —, “Information Warfare in the Second (1999–) Chechen War: Motivator for Military Reform?” in Anne C. Aldis and Roger N. McDermott, eds., *Russian Military Reform 1992–2002*, London: Frank Cass, 2003.

TotalWarTV, “Pro-Russian Rebel Tank Hit by Ukrainian Army ATGM,” June 8, 2015. As of March 29, 2016:

<http://www.totalwartv.com/video/pro-russian-rebel-tank-hit-by-ukrainian-army-atgm/>

Training Circular 2.91-4, *Intelligence Support to Urban Operations*, Washington, D.C.: Headquarters, Department of the Army, December 2015.

United Nations, Department of Economic and Social Affairs, Statistics Division, *World Statistics Pocketbook 2009*, Series V, No. 34, 2009. As of March 28, 2016:

<http://unstats.un.org/unsd/pocketbook/Pocketbook%202009.pdf>

"U.S. Army Asymmetric Warfare Training Center," *CSPAN*, May 6, 2015. As of November 16, 2015:

<http://www.c-span.org/video/?325682-5/washington-journal-colonel-john-petkosek-asymmetric-urban-warfare>

U.S. Army, "Introduction to Biometrics and Biometric Systems," undated. As of July 8, 2015:

<http://www.tam.usace.army.mil/Portals/53/docs/UDC/Training/Biometrics%20101.pdf>

U.S. Army, *The Megacity: Operational Challenges for Force 2025 and Beyond*, Army Chief of Staff's Future Study Plan, Washington, D.C., 2014.

U.S. Army Combined Arms Center, *The Human Dimension White Paper: A Framework for Optimizing Human Performance*, Fort Leavenworth, Kan., October 9, 2014, As of June 12, 2015:

<http://usacac.army.mil/sites/default/files/documents/cact/HumanDimensionWhitePaper.pdf>

U.S. Army Training and Doctrine Command, *The U.S. Army Operating Concept: Win in a Complex World*, TRADOC Pamphlet 525-3-1, Fort Eustis, Va., 2014.

Wallwork, Richard D., *Artillery in Urban Operations: Reflections on Experiences in Chechnya*, thesis, U.S. Army Command and General Staff College, 2004. As of July 21, 2016: handle.dtic.mil/100.2/ADA429031

West, Bing, *No True Glory: A Frontline Account of the Battle for Fallujah*, New York: Bantam Publishers, 2006.

Winton, Harold R., and David Mets, *The Challenge of Change: Military Institutions and New Realities, 1918-1941*, Lincoln, Neb.: University of Nebraska Press, 2003.

World Bank, "Internet Users (Per 100 people)," undated. As of July 8, 2015: <http://data.worldbank.org/indicator/IT.NET.USER.P2/countries/1W?display=graph>

Wright, Austin, "The Army's Multibillion Dollar 'Money Pit,'" *Politico*, May 29, 2013. As of July 6, 2015:

<http://www.politico.com/story/2013/05/army-battlefield-intelligence-network-91991.html>

Wright, Donald P., and Timothy R. Reese, *On Point II: Transition to the New Campaign*, Fort Leavenworth, Kan.: Combat Studies Institute, 2008.

Xu, Beina, "Media Censorship in China," *Council on Foreign Relations Backgrounder*, April 7, 2015. As of July 21, 2016:

<http://www.cfr.org/china/media-censorship-china/p11515>

Urban environments pose significant challenges for ground forces and have traditionally been avoided when at all possible, but increasing urbanization of the world's population seems to ensure that urban combat is in the Army's future. This report provides a historical analysis of the ways in which militaries have deployed light and mechanized infantry with armored forces during close urban combat, looking specifically at the U.S. Army in Mogadishu in 1993, the Russian Army in Grozny in 1994 and in 1999, the U.S. Army in Baghdad in 2003, the

U.S. Marine Corps and U.S. Army in Fallujah in 2004, and the U.S. Army in the Sadr City suburb of Baghdad in 2008. The authors assess the advantages and costs of this warfighting approach and identify lessons that can inform how the Army might confront similar foes in complex, urban environments in the future.

The authors find that urban combat operations have historically been among the most arduous challenges an army can face and that there are important gaps in the U.S. Army's capabilities to succeed in urban combat. The authors specifically discuss the critical role that effective intelligence plays in urban combat, and they offer broad recommendations on the implications of urban operations for Army warfighting challenges and for Army doctrine, organization, training, materiel, leadership, personnel, and facilities.



ARROYO CENTER

www.rand.org

\$33.50

ISBN-10 0-8330-9607-9
ISBN-13 978-0-8330-9607-4



9 780833 096074