



ARL-TR-8469 • AUG 2018



Routing in Software-Defined Mobile Ad hoc Networks (SD-MANET)

by Vinod K Mishra, Ayush Dusia, and Adarsh Sethi

Approved for public release; distribution is unlimited.

NOTICES

Disclaimers

The findings in this report are not to be construed as an official Department of the Army position unless so designated by other authorized documents.

Citation of manufacturer's or trade names does not constitute an official endorsement or approval of the use thereof.

Destroy this report when it is no longer needed. Do not return it to the originator.



Routing in Software-Defined Mobile Ad hoc Networks (SD-MANET)

by Vinod K Mishra

Computational and Information Sciences Directorate, ARL

Ayush Dusia and Adarsh Sethi

*Department of Computer and Information Sciences,
University of Delaware, Newark, DE 19716*

REPORT DOCUMENTATION PAGE

Form Approved
OMB No. 0704-0188

Public reporting burden for this collection of information is estimated to average 1 hour per response, including the time for reviewing instructions, searching existing data sources, gathering and maintaining the data needed, and completing and reviewing the collection information. Send comments regarding this burden estimate or any other aspect of this collection of information, including suggestions for reducing the burden, to Department of Defense, Washington Headquarters Services, Directorate for Information Operations and Reports (0704-0188), 1215 Jefferson Davis Highway, Suite 1204, Arlington, VA 22202-4302. Respondents should be aware that notwithstanding any other provision of law, no person shall be subject to any penalty for failing to comply with a collection of information if it does not display a currently valid OMB control number.

PLEASE DO NOT RETURN YOUR FORM TO THE ABOVE ADDRESS.

1. REPORT DATE (DD-MM-YYYY) August 2018		2. REPORT TYPE Technical Report		3. DATES COVERED (From - To) October 2017–May 2018	
4. TITLE AND SUBTITLE Routing in Software-Defined Mobile Ad hoc Networks (SD-MANET)				5a. CONTRACT NUMBER	
				5b. GRANT NUMBER	
				5c. PROGRAM ELEMENT NUMBER	
6. AUTHOR(S) Vinod K Mishra, Ayush Dusia, and Adarsh Sethi				5d. PROJECT NUMBER	
				5e. TASK NUMBER	
				5f. WORK UNIT NUMBER	
7. PERFORMING ORGANIZATION NAME(S) AND ADDRESS(ES) US Army Research Laboratory Computational and Information Sciences Directorate (ATTN: RDRL-CIH-S) Aberdeen Proving Ground, MD 21005				8. PERFORMING ORGANIZATION REPORT NUMBER ARL-TR-8469	
9. SPONSORING/MONITORING AGENCY NAME(S) AND ADDRESS(ES)				10. SPONSOR/MONITOR'S ACRONYM(S)	
				11. SPONSOR/MONITOR'S REPORT NUMBER(S)	
12. DISTRIBUTION/AVAILABILITY STATEMENT Approved for public release; distribution is unlimited.					
13. SUPPLEMENTARY NOTES					
14. ABSTRACT Software-Defined Networking principles are applied to Mobile Ad Hoc Networks (MANETs) to establish and maintain wireless multihop peer-to-peer connectivity between the nodes without any infrastructure support. The conventional MANET solutions use distributed routing and provide limited flexibility and programmability for introducing new services in MANETs. In this report, we propose an architecture for Software-Defined MANETs, describe benefits and challenges of centrally managed MANETs, implement it in NS-3 simulator, and evaluate its performance. Results are compared with the conventional MANET solutions. We demonstrate an improvement in the control communication overhead of establishing and maintaining the network routes.					
15. SUBJECT TERMS Software-Defined Networking, Mobile Ad hoc Networks, networking architecture, NS-3 simulation, MANET routing					
16. SECURITY CLASSIFICATION OF:			17. LIMITATION OF ABSTRACT UU	18. NUMBER OF PAGES 34	19a. NAME OF RESPONSIBLE PERSON Vinod K Mishra
a. REPORT Unclassified	b. ABSTRACT Unclassified	c. THIS PAGE Unclassified			19b. TELEPHONE NUMBER (Include area code) (410) 278-0114

Contents

List of Figures	iv
1. Introduction	1
2. Related Work	2
3. Proposed SD-MANET Architecture	3
4. Proposed SD-MANET Routing Protocol: Both Learning and Transmission Proactive	6
4.1 Maintaining Route to SDNC	6
4.2 Learning Network Topology by TM	9
4.3 Sending Network Routes	11
5. Simulation Experiments	12
5.1 Small Networks	13
5.2 Large Networks	15
5.3 High Node Speeds	17
5.4 High Interference	19
5.5 Low Node Density	20
6. Conclusions	22
7. References	24
List of Symbols, Abbreviations, and Acronyms	26
Distribution List	28

List of Figures

Fig. 1	SD-MANET architecture	4
Fig. 2	Internal architecture of an SD-MANET node.....	5
Fig. 3	Node A sent an NDM with SN = 0, HC = 0	7
Fig. 4	SDNC sent an NDM with SN = 2, HC = 0	7
Fig. 5	Node B sent a TNDM with the last received NDM's SN.....	7
Fig. 6	Node C sent a TNDM with the last received NDM's SN.....	8
Fig. 7	Node A sent an NIM to the SDNC by including its neighbor and link quality lists	10
Fig. 8	Node F sent an LEM to the SDNC	11
Fig. 9	SDNC sent an RUM to Node A.....	11
Fig. 10	Node A sent an RUAM to SDNC	12
Fig. 11	Evaluations result of the simulation experiments for small networks	14
Fig. 12	a) Average number of times a data packet is forwarded and b) total failed MAC layer data transmissions.....	15
Fig. 13	a) Average size of control messages in SDMANET and OLSR, and b) Average MAC transmissions for a successfully delivered data packet.	15
Fig. 14	Evaluations result of the simulation experiments for large networks.	16
Fig. 15	a) Total control packets and b) success delivery percentage of the RUM messages	17
Fig. 16	a) Average MAC transmissions for a successfully delivered data packet and b) average size of control messages.....	17
Fig. 17	Result of the simulation experiments for networks with high node speed	18
Fig. 18	a) Success delivery percentage of the RU messages and b) total failed MAC layer retransmissions.....	19
Fig. 19	Simulation experiments for networks with high interference.....	19
Fig. 20	a) Total packets in the network and b) average MAC transmissions for a successfully delivered data packet	20
Fig. 21	Simulation results for network with low node density	21
Fig. 22	a) Size distribution of control messages with increase in simulation area and b) average number of time a data packet is forwarded in the network	22

1. Introduction

Over the last few years, Software-Defined Networking (SDN) has been applied to the architecture of many different types of networks. SDN separates the control functions from forwarding ones and puts it in a central entity called SDN Controller (SDNC). This approach has many advantages, including the following:

- The forwarding devices can be dynamically controlled, changed, and managed.
- Services, such as load balancing, firewall, access control, quality of service (QoS), and network monitoring, and others can be moved to the SDNC for centralized handling.
- The network becomes more programmable and that improves the management and utilization of the available network resources.

A Mobile Ad hoc Network (MANET) is a group of mobile nodes communicating without a fixed wireless infrastructure. A typical MANET node has a limited wireless transmission range, and intermediate MANET nodes relay network packets over multihop routes. Currently, each such node supports the functions of a forwarding device and an end host, and also has some control functions. Nodes move arbitrarily, causing dynamic changes to the network topology. MANETs support a wide range of scenarios, such as military operations, emergency search and rescue, disaster relief, Internet connectivity to remote regions, vehicular networks, and sensor networks.

The application of SDN principles to MANET requires a reliable Transmission Control Protocol connection between SDNC and each forwarding node for control messages. But MANET characteristics like node mobility, intermittent links, and the dynamic topology make the connections between the nodes unreliable. Common protocols like OpenFlow¹ and ForCES² were not designed for such conditions. Furthermore, their control message sizes may be too large for MANET environment with scarce bandwidth.

Most of the recently proposed SDN-based MANET (SD-MANET) architectures assume that SDNC communicates with the node over a single hop link over a separate channel (e.g., cellular). In addition, a base station to host SDNC and a location service (e.g., GPS) for tracking the positions of the mobile nodes is also assumed to be available. The current proposal is designed for networks with no infrastructure, and does not assume this, so that

- the SDNC is hosted in one of the mobile nodes in the network,

- the SDNC communicates with a node over multihop routes in general, and
- no location service is used for tracking the positions of the nodes.
- In this environment the SDNC is required to perform following functions for efficient routing:
 - SDNC sends route updates to all nodes in the network for every change in the network topology.
 - SDNC continuously collects the connectivity information from the nodes and learns the network topology.
 - Each node maintains a route to SDNC.

Routing protocols meeting these requirements can be designed considering the needs for proactive, reactive, and hybrid routing approaches. This report describes a proactive routing protocol which is implemented in the NS-3 simulator. The performance metrics are calculated using various networking scenarios and with the result from the Optimized Link State Routing Protocol (OLSR).

2. Related Work

Several different SDN-based architectures have been proposed in the past that make the assumptions mentioned earlier.

- Dely et al.³ propose a Wireless Mesh Networks architecture using OpenFlow-enabled devices as mesh access points and gateways. SDNC triggers and manages the handover of mobile nodes between the access points, and the OLSR routing protocol is used for multihop routing.
- De Gante et al.⁴ describe a Wireless Sensor Network architecture with SDNC as part of a stationary base station with direct control link to the sensor nodes. The SDNC learns network topology by gathering the node position information via a location service, which it uses to select network routes and update the sensor node flow table.
- Wang et al.⁵ implement source routing in a multihop wireless network. A node requesting a path from SDNC receives a list of relay nodes, which is included in data packets for the relay nodes to read and forward the packets.
- Yu et al.⁶ propose a direct link for control communication between each node and SDNC.
- Doshi et al.⁷ propose a hierarchical distributed control plane in which a network is divided into domains, and each domain is managed by a single

SDNC. All SDNCs form a tree to communicate with one another. The routing functions remain distributed in the nodes, while all other control functions are moved inside the SDNC.

SDN-based architectures have been proposed for Vehicular Ad hoc Networks,⁸⁻¹⁰ as well. In all of them, SDNC is located at a base station and sends route updates to roadside units (RSUs) and vehicles.

- Architectures proposed in Zhu et al. and He et al. assume that the vehicles remain connected to the Internet, or a cloud infrastructure, via a cellular connection.^{11,12}
- For issues related to loss of connectivity with the SDNC, a clustering technique is proposed by Correia et al.,¹³ in which a few small domains are created, and a cluster head acting as the local SDNC is selected for each domain. Each vehicle periodically shares its position, velocity, direction vectors, cluster to which it belongs, and its role in the said domain. If a route is not available to the vehicle, a request message is sent to the local SDNC, which then forwards the message to other local SDNCs using a gateway selection algorithm for finding a path to the destination vehicle/RSU.

All these architectures require an infrastructure to host the SDNC and an out-of-band communication channel in the form of Long-Term Evolution or WiFi/WiMAX, for sending the control messages. Our proposal does not assume these conditions.

3. Proposed SD-MANET Architecture

The proposed SD-MANET architecture (Fig. 1) has the following features:

- The SDNC is hosted in one of the mobile nodes.
 - It sends routes updates to all the other nodes in the network, hosts data applications, and relays data packets.
 - The routing function is implemented as an application inside the SDNC and it is responsible for selecting network routes and sending route updates to all other nodes in the network.
 - The SDNC continuously collects the connectivity information from all the nodes and learns the network topology. Each node maintains a route to the SDNC to receive connectivity information.

- All nodes are mobile and act both as forwarding devices and end hosts. They have limited wireless transmission ranges, so both the control and the data communications take place over multihop routes.

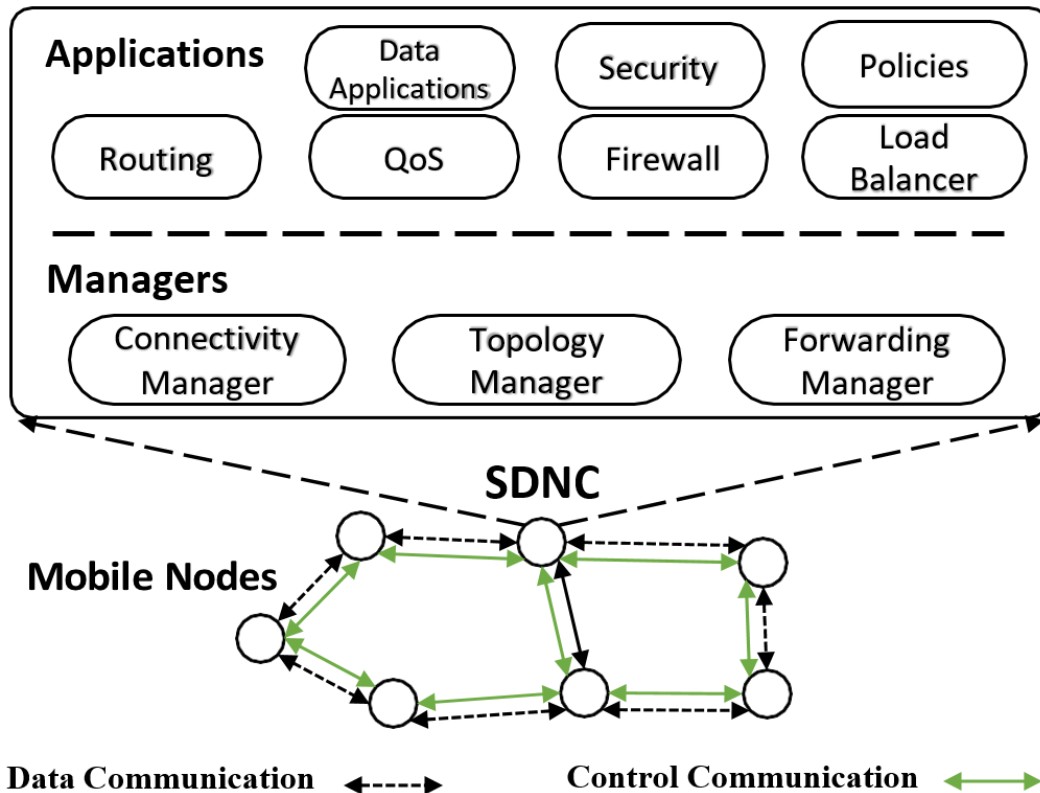

Fig. 1 SD-MANET architecture

The SDNC performs three main network functions using its internal modules:

- 1) It allows each node to maintain a route to itself with the help of a Connectivity Manager (CM). The network topology changes frequently, but nodes need to maintain a route to the SDNC for sending their control messages. The CM helps nodes to perform this task.
- 2) It learns network topology through a Topology Manager (TM). The SDNC needs to continuously learn the global view of the network. This view has information regarding the number of nodes in the network and the connectivity between the nodes. The TM is responsible for collecting and maintaining this information.
- 3) It sends network routes using Forwarding Manager (FM). Routes that are currently installed in the flow tables of nodes are maintained in a centralized repository at the SDNC. This information constitutes a part of network state information maintained at the SDNC.

The applications connected to the SDNC via North Bound Interfaces provide policies so that the SDNC can determine network routes and make decisions regarding load balancing, QoS, firewall, and more.

The three basic layers (Application, Control Plane, and Data Plane) of the architecture are shown in Fig. 1. The internal architecture of the node is shown in Fig. 2. The node follows the following rules:

- It forwards data packets of its own applications as well as data packets from the applications in other nodes.
- Each node has a Flow Table (FT) similar to that of an OpenFlow-enabled Forwarding Device (FD). The FT contains the rules for forwarding the flows received from the applications or from another node. The node routing application communicates with the routing applications in other nodes using User Datagram Protocol (UDP) and updates the FT route entries.

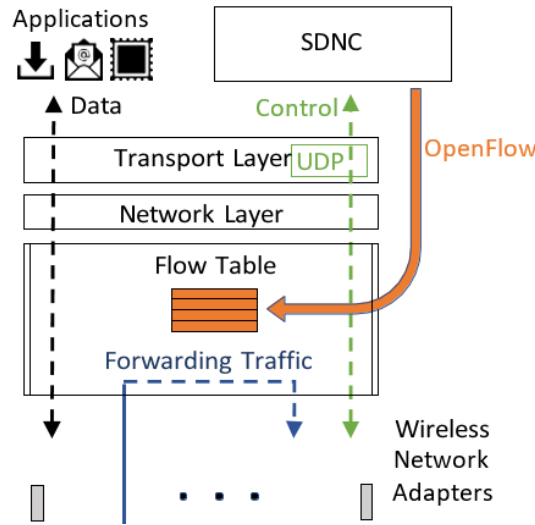

Fig. 2 Internal architecture of an SD-MANET node

In the standard SDN architecture, each FD has an agent for communicating with SDNC using the OpenFlow protocol and installs FT routes. In the proposed SD-MANET architecture, each FD has a Local Controller (LC) with similar functions but with a key difference: The SDNC-to-LC communication does not use the OpenFlow protocol because the size of its messages may be too large for a scarce-bandwidth MANET environment. The LC converts the routing information sent by SDNC into OpenFlow messages to be used by the FT. This is different from the standard SDN architecture. The conversion of the routing information into

OpenFlow messages allows the SD-MANET architecture to leverage all the benefits of SDN.

We assume that the nodes could be equipped with one or more Wireless Network Adapters (WNAs). A single WNA can be used for in-band control and data communications. For differentiating between control and data packets, a flow rule entry is installed in the FT for forwarding the control packets to the local controller. The port number in the transport header of packets is used for identifying control packets.

In this scheme, each node should always maintain a route to the SDNC for sending control messages. However, the network topology can be learned, and network routes could be sent in a proactive or a reactive manner. Thus a non-OpenFlow routing protocol for SD-MANET can be designed in several possible ways made possible by 1) the separation of CP functions from nodes, 2) separation of CP functions from each other, and 3) centralization of the decision-making process. So the following three options are viable for SD-MANET routing protocols:

- 1) **Proactive** (network topology learning)—**Proactive** (network routes transmission)
- 2) **Proactive** (network topology learning)—**Reactive** (network routes transmission)
- 3) **Reactive** (network topology learning)—**Reactive** (network routes transmission)

4. Proposed SD-MANET Routing Protocol: Both Learning and Transmission Proactive

In this scenario the network topology is proactively learned and the routes are also proactively sent by SDNC. The messages are the UDP packet payloads designed according to MANET packet/message format specifications described in Clausen et al.¹⁴

4.1 Maintaining Route to SDNC

Each node periodically sends a Neighbor Discovery Message (NDM) containing its Hop Count (HC) to the SDNC and a Sequence Number (SN) and adds a random delay to the transmission. An NDM acts as a Hello message and helps the receiver nodes to discover or verify link connectivity from the sender node. Each node maintains a list of neighbor nodes from which it has received NDMs. The receiver node uses the NDM update or maintains its next hop node on the Route-to-SDNC

(RTS). CM initializes and increments the SN. Figure 3 shows a running SD-MANET example in which no node has a route to SDNC yet. Figures 4–6 show the steps involved in maintaining a route.

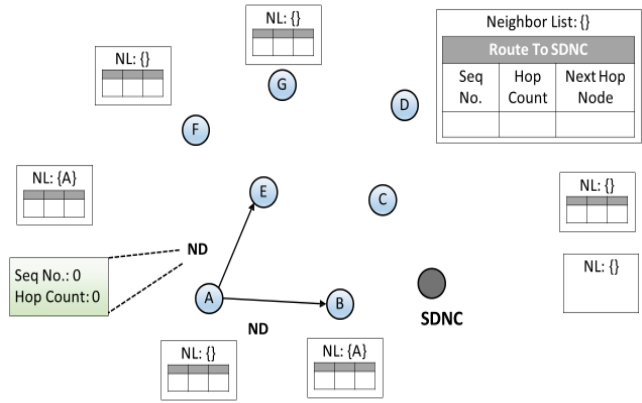

Fig. 3 Node A sent an NDM with SN = 0, HC = 0

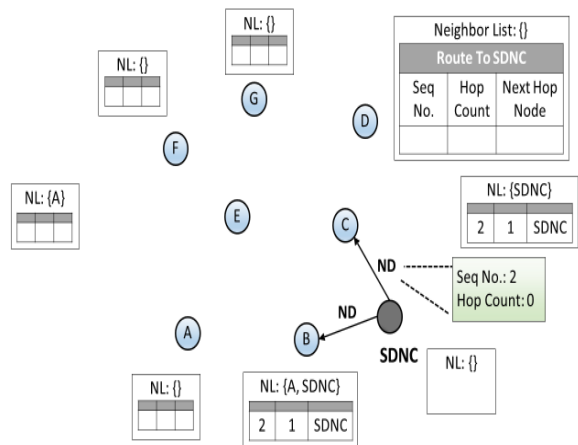

Fig. 4 SDNC sent an NDM with SN = 2, HC = 0

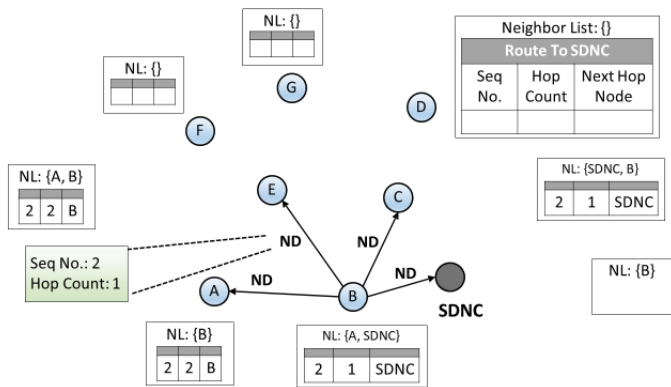

Fig. 5 Node B sent a TNDM with the last received NDM's SN

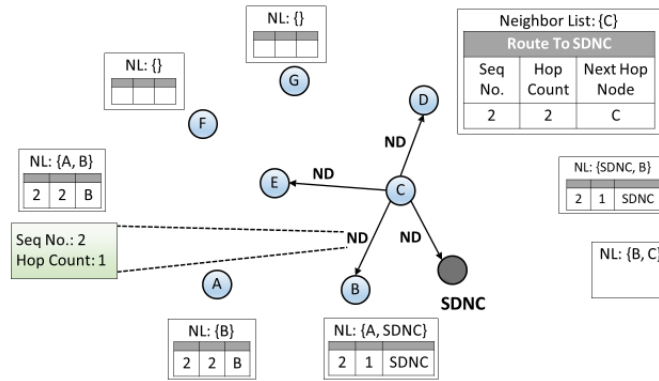

Fig. 6 Node C sent a TNDM with the last received NDM's SN

- In Fig. 3, Node A sends an NDM with SN = 0 and HC = 0. Nodes B and E receive it and add node A to their Neighbor List (NL) but do not update their RTS because a valid SN has non-zero SN.
- In Fig. 4, the NDM sent by the SDNC has SN = 2, HC = 0. Messages sent by the SDNC start by SN = 2 and increment by 2, remaining always even. Also, HC = 0 because it is the distance of the SDNC from itself. Nodes B and C receive NDM and add SDNC to their NL. They also update their RTS, such that the next hop node on the RTS is set to SDNC, plus SN = 2, and HC = 1 is set. An update to the RTS causes nodes B and C to send a Triggered ND Message (TNDM) each, and advertise their newly updated route. The periodic transmission of NDM is rescheduled to the next interval when a TNDM is sent.

TNDMs help quickly propagate the update in the RTS information to other nodes in the network. To avoid route fluctuations in the network, a Route Settling Time (RST) is used for sending TNDM. The transmission of TNDMs is delayed by RST and it is a function of the HC of the sender node from the SDNC. A node that is closer to the SDNC will have a smaller RST.

In Fig 5, Node B sends TNDMs to Nodes A, E, and C, which update their NL, and also to the SDNC, which ignores the route information in it and just updates its NL by adding Node B.

In Fig 6, Node C sends TNDMs to Nodes B, E, D, and the SDNC, which update their NLs by adding C. However, the RTS is only updated by Node D, because Node B already had a better route (i.e., with the HC = 1) to the SDNC, and Node E already had a similar route (i.e., with SN = 2 and HC = 2) to the SDNC. A TNDM is sent only when the RTS is updated. Otherwise, the scheduled transmission of NDMs occurs. The route is updated and TNDMs are sent if the route is received 1) for the

first time or 2) it has a newer SN or the same SN but a smaller HC. The RTS is not updated if the received route 1) has an older SN or 2) it has the same SN but the same or larger HC.

Each node maintains a holding timer (set to three times the value of the periodic interval of NDMs) for its RTS. If the route is not updated within that time, then a route failure is reported in the next periodic transmission of an NDM. Route failure is indicated by incrementing the SN by 1 to make it an odd number. A node that receives an NDM with an odd SN from its next hop node on the RTS invalidates its current route and sends a TNDM by including the received odd SN. The TNDM is sent without delaying it by an RST. If the sender node of an NDM with an odd SN is not the receiver node's next hop node on the RTS, then the reported route failure is ignored.

The route is updated and TNDMs are sent for the route received 1) for the first time, 2) with a newer SN, or 3) with the same SN but with a smaller HC. The route to the SDNC is not updated for the route received 1) with an older SN or 2) with the same SN but the same or larger HC.

4.2 Learning Network Topology by TM

The TM helps the SDNC learn the network topology and maintain a connectivity map by collecting connectivity information from all the nodes. An NL is maintained by each node with the help of the NDM. The quality of the link from each neighbor is estimated by the following equations:

$$LQ_n = LQ_{n-1} * (1 - \alpha) + \alpha \text{ (for a successfully received NDM)} \quad (1)$$

and

$$LQ_n = LQ_{n-1} * (1 - \alpha) \text{ (for a missed NDM),} \quad (2)$$

where LQ_n and LQ_{n-1} are current and previous link quality values respectively, $\alpha = 0.5$ is the weight and $LQ_0 = 0$. A threshold value of $\alpha = 0.25$ is the link quality to determine if the NL includes or excludes the neighbor node. The NL sends a Neighbor Information Message (NIM) to the SDNC for updating the connectivity map of nodes. NIMs are sent periodically by each node so that a global view of the network can be maintained by the SDNC.

Figure 7 shows that Node A sent an NIM to the SDNC after learning the route from the NDM. Node A also sends the NIM its next hop node (i.e., Node B), which then forwards it to its next hop node (i.e., directly to the SDNC).

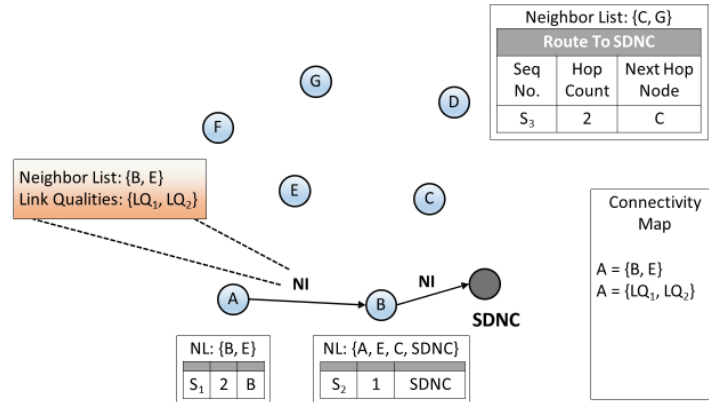

Fig. 7 Node A sent an NIM to the SDNC by including its neighbor and link quality lists

If a neighbor node moves away and causes a link failure, it may take a while for the link quality to go below the threshold for its removal from the NL. During this time period, the neighbor node would still be a part of the NL sent to the SDNC. If the FT contained a route for forwarding data packets to this absent node, they will be dropped by the link layer because of missed Clear To Send (CTS)—Media Access Control (MAC) layer drops the packet if CTS was not received or the RTS message has been sent the maximum allowed number of times—or missed Acknowledgment Data Network (ACK)—MAC layer drops the packet if the maximum retransmission attempts have been made. If the link layer provides this packet drop feedback to the local controller, the node is removed from the NL, and a Link Error Message (LEM) is sent to SDNC for a quick reporting of the link failure. The LEMs are sent to the SDNC in the same way as the NIM, and they help SDNC quickly learn about the changes to the topology and update its global view of the network.

In Fig. 8, Node F was sending data packets to Node G, but Node G went out of the transmission range of Node F, so packets were dropped. Then Node F used the packet drop feedback in the form of missed CTS or ACK to send an LEM to the SDNC and also forwards it to the next hop Node E, which then forwards it to its next hop Node B and the finally to the SDNC. The SDNC uses a LEM to update its connectivity map by removing Node G from the Node F's NL.

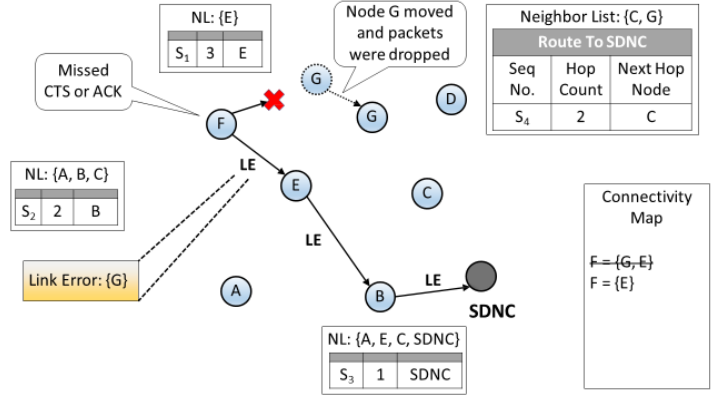

Fig. 8 Node F sent an LEM to the SDNC

4.3 Sending Network Routes

Routes are periodically selected by the SDNC using the most recent view of the network and also Dijkstra's algorithm for selecting All Possible Shortest Routes (APSRs) between each pair of nodes. If the previously sent route is a part of the newly selected APSR, a route update is not sent. A route update is sent when 1) the routes are selected for the first time or 2) the previously sent route is not a part of the newly selected APSR. A route is randomly selected from the APSR list and sent.

The FM in SDNC prepares the FT using the selected routes and sends it to the node as Route Update Message (RUM). The FT information included in the RUM can be used by the LC for installing Flow Routes (FRs) in the node FT. The FRs follow the OpenFlow message format for flow-based forwarding. The FM selects a route and includes the destination in the RUM before sending it to its destination. Figure 9 shows that the SDNC includes the FT of Node A in RUM and sends it to Node B, which sends it to Node A after reading the message path in RUM.

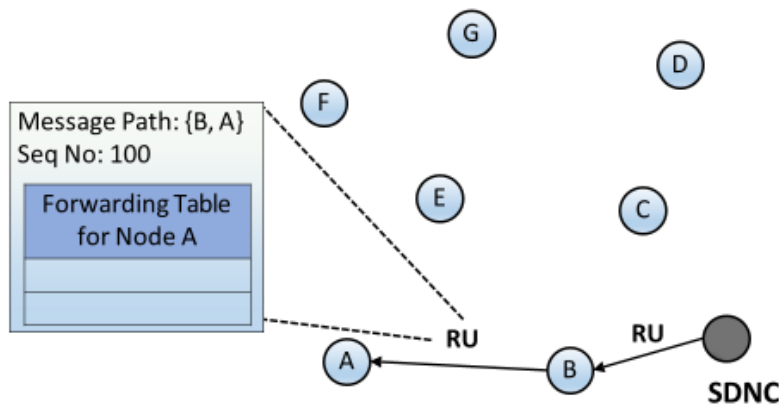

Fig. 9 SDNC sent an RUM to Node A

In a dynamic environment, sometimes the RUMs do not reach their destinations. A possible option is to include the full FT in every RUM, but this will increase the control message overhead in the network. In the approach adopted here, the node receiving an RUM sends acknowledgments to the DNC for every successfully received RUM in a Route Update Acknowledgment Message (RUAM) so that only the incremental route updates are sent. Figure 10 shows that Node A sends an RUAM to the SDNC with acknowledgment number of 100, which was the SN in the received RUM. The acknowledgment helps SDNC update its global forwarding information with the routes that were successfully delivered as opposed to those that were sent but not delivered. Thus, in the next periodic transmission of RUM, reference is made to the global forwarding information, and so the RUM only includes the changed and unacknowledged routes. This reduces the RUM size and the overall routing overhead in the network, as the FT need not be sent with every RUM.

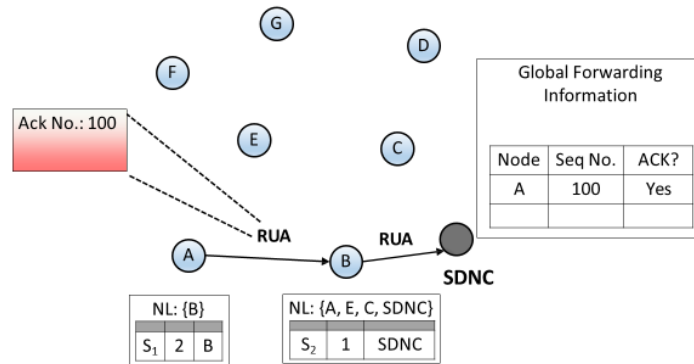

Fig. 10 Node A sent an RUAM to SDNC

5. Simulation Experiments

The SD-MANET architecture and the proactive routing protocol are implemented in the NS-3 simulator and their performance is evaluated in several network scenarios. The results are compared with the OLSR routing protocol. For each simulation experiment, the runtime is 200 simulated seconds, of which the first 50 are used for start-up time. The results used for comparison are the average of 20 runs. Nodes are positioned in a rectangular area 800×800 m using the randomness algorithm described L'Ecuyer et al.¹⁵ Data applications are configured in 10 nodes, which send data to a different set of 10 nodes in the network.

- Each node is equipped with a single wireless network adapter working in the ad hoc mode with the IEEE 802.11b wireless standard. The RTS/CTS threshold = 0, so all unicast packets require RTS/CTS handshakes. The wireless channel propagation loss is configured using the Friis propagation loss model.¹⁶

- A UDP-based application generates data at the rate of 48 Kb/s and starts sending data packets at a time selected randomly between 50 and 51 s.
- Mobility in the nodes is configured using the random waypoint model with node speed of 5 m/s. The intervals used for Neighbor Discovery (ND), Neighbor Information (NI), and route update (RU) control messages of SD-MANET routing protocol are 2, 2, and 3 s, respectively. The intervals used for Hello and TC control messages of LSR are 2 and 5 s, respectively.
- The following network metrics are used for comparing the two routing approaches:
 - Average Throughput (AT) is the average rate at which the application data is successfully received by the destination nodes.
 - Total Control Communication Overhead (TCCO) shows the routing overhead in the network, and it is the cumulative size of the control messages exchanged by nodes over the lifetime of simulation.
 - Packet Delivery Ratio (PDR) is the ratio of data packets successfully delivered to data packets sent.
 - Average end-to-end delay (Ae2eD) is the average time used by the data packets to successfully reach their destinations nodes.

5.1 Small Networks

Small networks have sizes ranging from 30 to 50 nodes. Figure 11 shows the results.

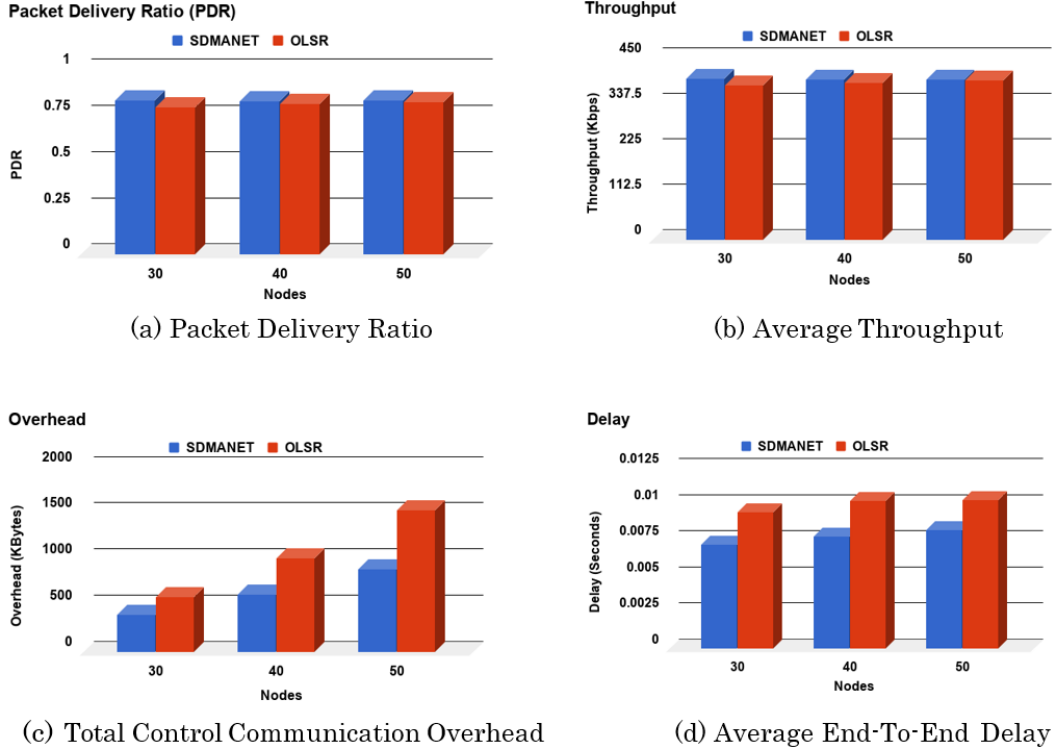

Fig. 11 Evaluation results of the simulation experiments for small networks

The results show that 1) the PDR and the AT are almost the same for both SD-MANET and OLSR, and 2) TCCO and the Ae2eD are lower for SD-MANET than in OLSR. The lower overhead results from the encapsulation approach used for sending route updates in SD-MANET. On the other hand, the routing information is continuously exchanged in OLSR, resulting in large overhead.

The lower delay for SD-MANET could be a result of shorter routes selected by the SDNC using a centralized global view of the network. But the average number of times a data packet is forwarded within the two approaches (Fig. 12a) is almost the same. Thus, both SD-MANET and OLSR select routes of almost identical length. However, SD-MANET sends a control packet (except an NDM) as unicast, so transmissions of both the control and data packets use collision avoidance mechanisms. The use of RTS/CTS handshakes for sending the control and data packets results in fewer collisions and MAC layer retransmissions in SD-MANET. In OLSR, a control packet is sent as a broadcast, resulting in more collisions in a shared medium, and hence more MAC layer retransmissions for the data packets. Figure 12b shows a comparison of the failed MAC layer transmissions for data packets between SD-MANET and OLSR.

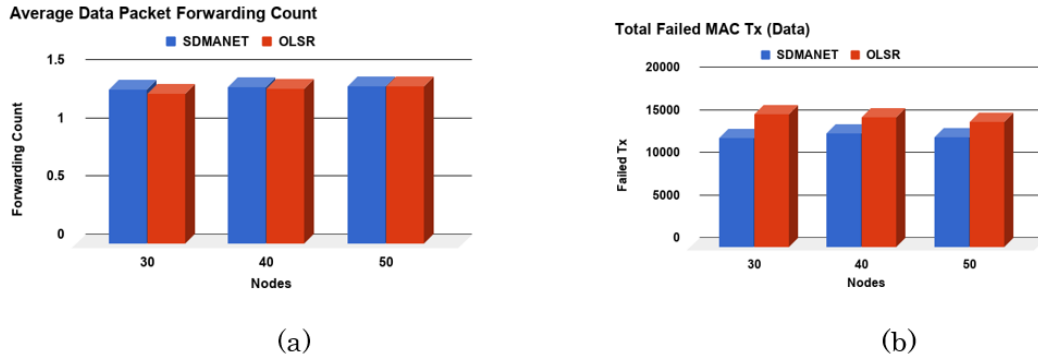

Fig. 12 a) Average number of times a data packet is forwarded and b) total failed MAC layer data transmissions

Figure 13a shows that the average size of control packets is much smaller in SD-MANET than in OLSR. The average MAC layer transmissions required for successfully delivering a data packet is shown in Fig. 13b. All these factors result in a lower Ae2eD in SD-MANET than in OLSR.

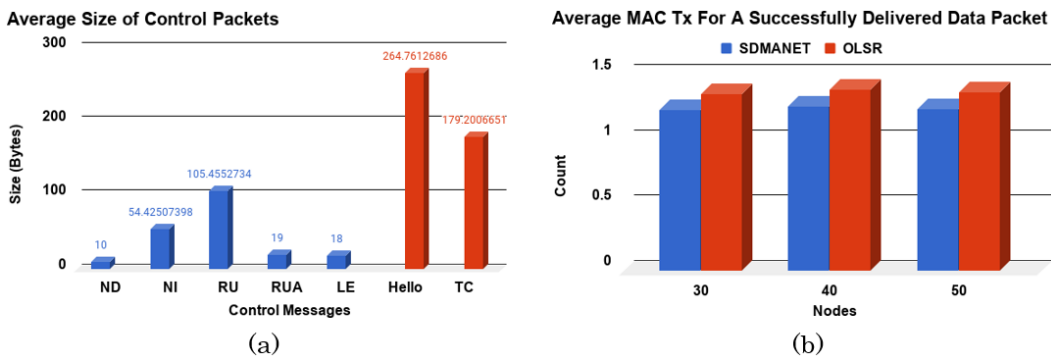

Fig. 13 a) Average size of control messages in SD-MANET and OLSR, and b) average MAC transmissions for a successfully delivered data packet

5.2 Large Networks

Networks sizes range from 50 to 100 nodes. Figure 14 shows the results.

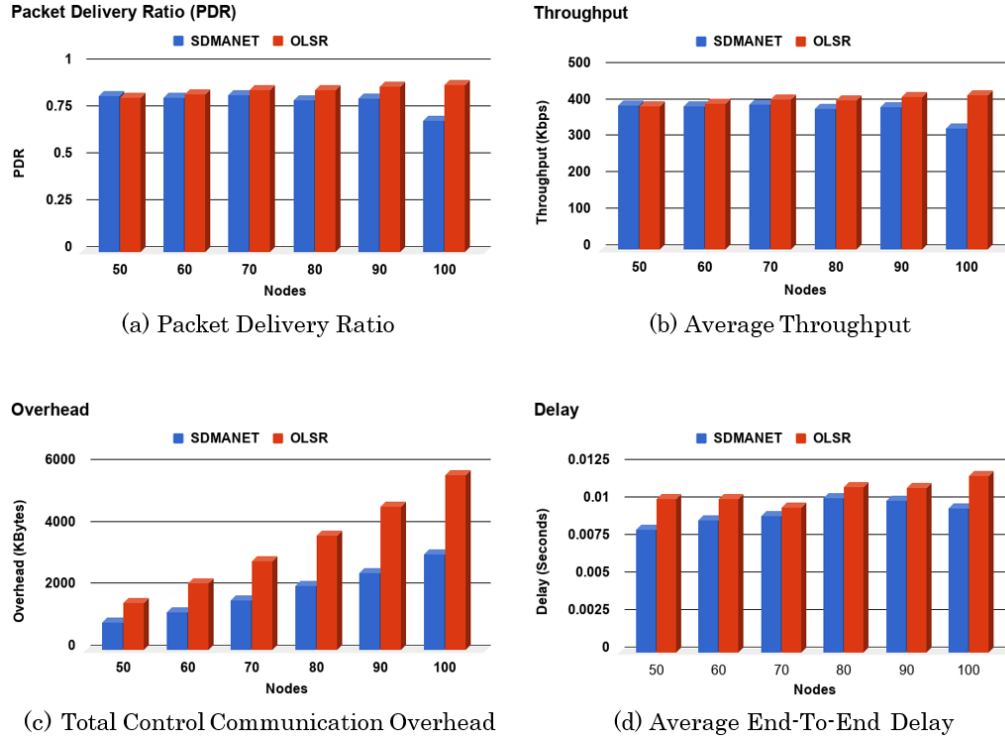

Fig. 14 Evaluation results of the simulation experiments for large networks

As the network size approaches 100, the difference between the SD-MANET and OLSR increases for both the PDR and AT. However, the TCCO and the Ae2eD remain lower with SD-MANET than with OLSR.

The reasons for low TCCO in SD-MANET remain the same as in the previous scenario. However, a reduction in the PDR and the AT is due to an increase in the total number of control packets in the network. Figure 15a shows a comparison of the total control packets transmitted in the network using SD-MANET and OLSR. Figure 15b shows a comparison of the RU successful delivery percentage from the SDNC to all other nodes. A decrease in the delivery percentage of the RUs causes more data packet transmission failures, as routes are not updated with changes in the network topology.

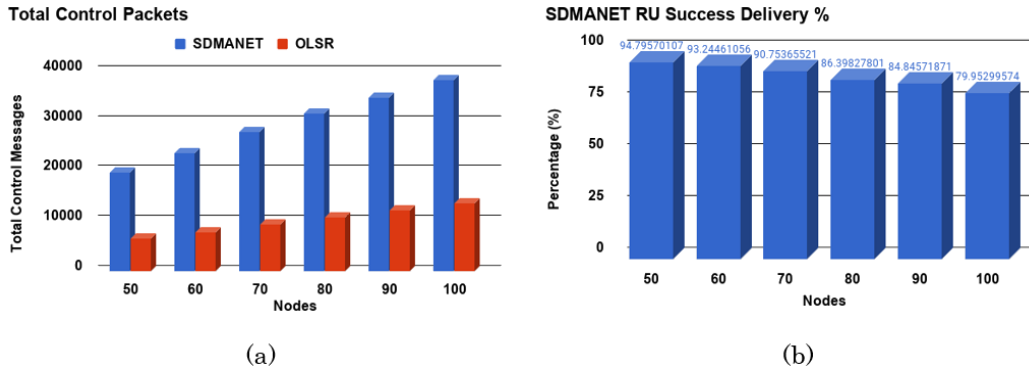

Fig. 15 a) Total control packets and b) success delivery percentage of the RUM messages

The Ae2eD remains lower for SD-MANET than for OLSR because the delay is calculated only for the successfully delivered data packets. When the FT in the node had a valid route, the MAC layer used fewer transmission attempts for forwarding a data packet in SD-MANET than does OLSR. These reduce the overall end-to-end delay in the network. Figure 16a shows a comparison of the average MAC layer transmissions required for successfully delivering a data packet. The MAC layer makes more transmissions attempts in OLSR due to 1) an increase in collisions due to the broadcast nature and 2) the large size of the control packets. Figure 16b compares the average size of control packet between SD-MANET and OLSR. Thus, even though there are more failed MAC layer transmissions in the network, the average transmissions for a successfully delivered data packet is lower for SD-MANET than for OLSR.

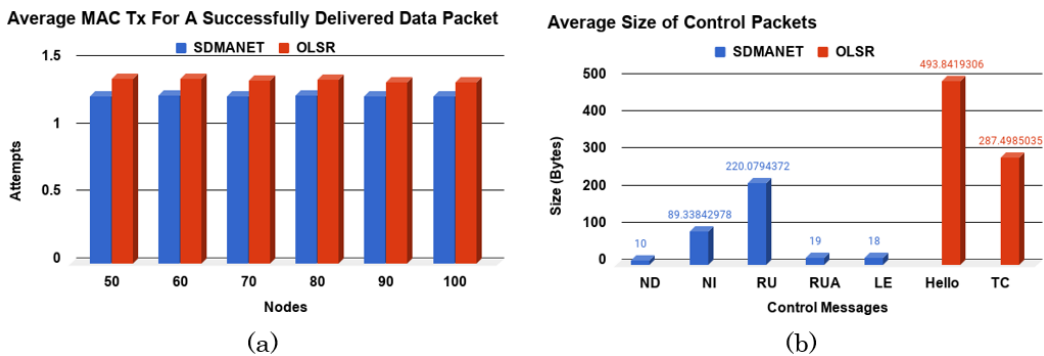

Fig. 16 a) Average MAC transmissions for a successfully delivered data packet and b) average size of control messages

5.3 High Node Speeds

Node speed range between 5 and 20 m/s for a 50-node network. Figure 17 shows the results.

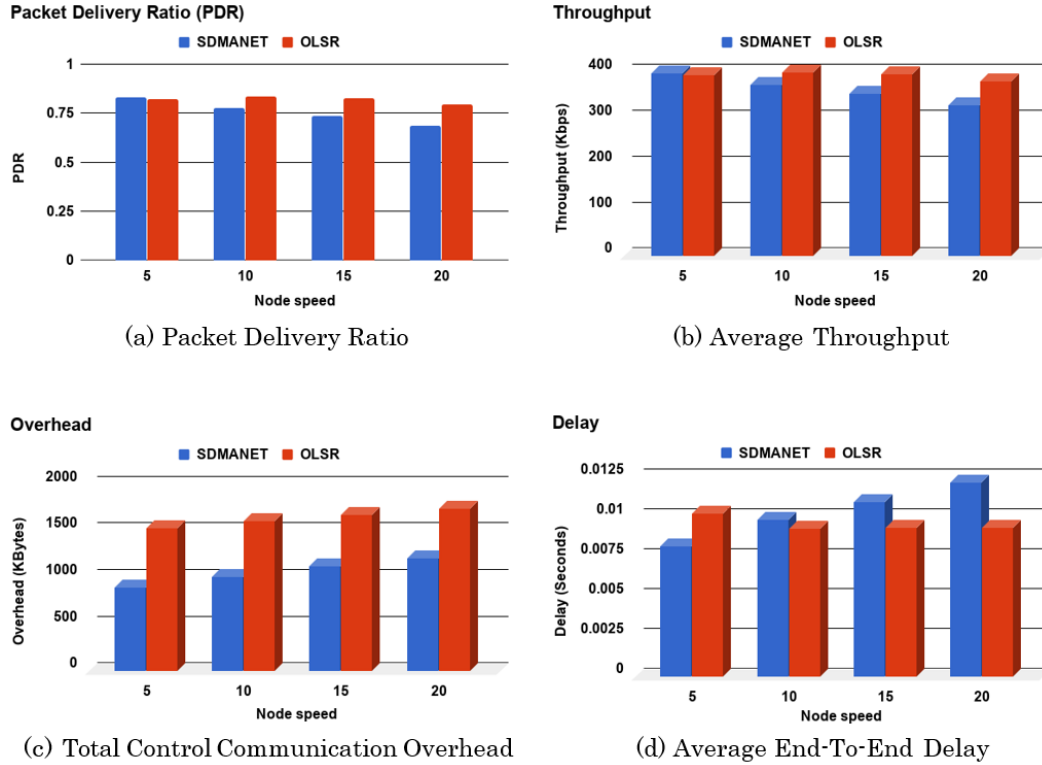

Fig. 17 Results of the simulation experiments for networks with high node speed

As the node speed increases, the PDR and the AT decrease in SD-MANET. The overhead increases in SD-MANET but it is always lower than the overhead in OLSR. The Ae2eD also increases in SD-MANET with the increase in node speed.

The decrease in the PDR and AT occurs due to fewer RUMs reaching the nodes. Figure 18a shows a decrease in the successful delivery percentage of the RUM with the increase in node speed. When the routes are not updated with the changes in the network topology, it results in more MAC layer retransmissions and data packet drops. Figure 18b shows a comparison of the total failed MAC layer transmissions with the increase in node speed. More attempts made by the MAC layer for transmitting data packets results in more collisions, thus increasing the overall end-to-end delay. Thus, the Ae2eD for SD-MANET is higher for networks with higher node speeds.

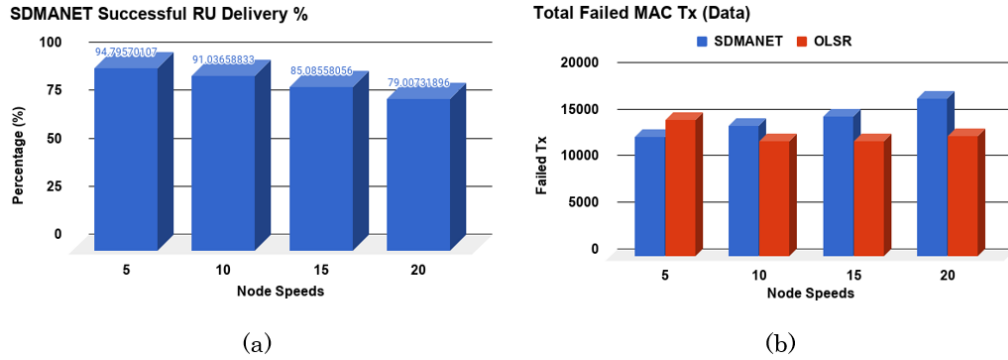

Fig. 18 a) Success delivery percentage of the RU messages and b) total failed MAC layer retransmissions

5.4 High Interference

Networks with increased interference are simulated. Interference is increased by reducing the size of data packets while keeping the data rate constant, leading to the generation of more data packets. The size of the data packets is varied between 1024 and 256 bytes. A network of 50 nodes is considered, and Fig. 19 shows the results. It is found that the PDR and AT remain almost the same in SD-MANET with a decrease in data packet size, but they increase in OLSR. The TCCO in SD-MANET remains the same for all packet sizes but lower than in OLSR because the network size remains the same.

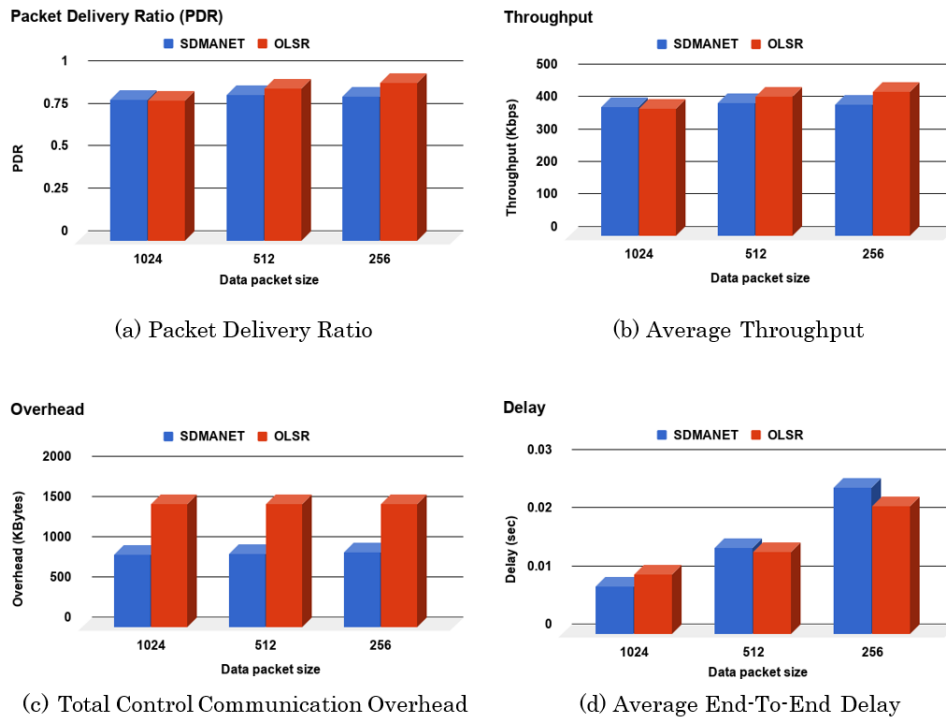

Fig. 19 Simulation experiments for networks with high interference

The Ae2eD is lower in SD-MANET for large-sized data packets (1024 bytes) but increases as the data packet size decreases (and interference increases). The increase in delay is due to the increase in the total number of packets in the network (Fig. 20a). In OLSR, large (1024 bytes) data packets interfere and collide with the broadcast and large-sized control packets, causing more retransmissions, an increase in end-to-end delay, and low throughput. However, the collisions decrease with decreasing data packets size, resulting in lower retransmission and end-to-end delay, and higher AT and PDR (Figs. 19 and 20).

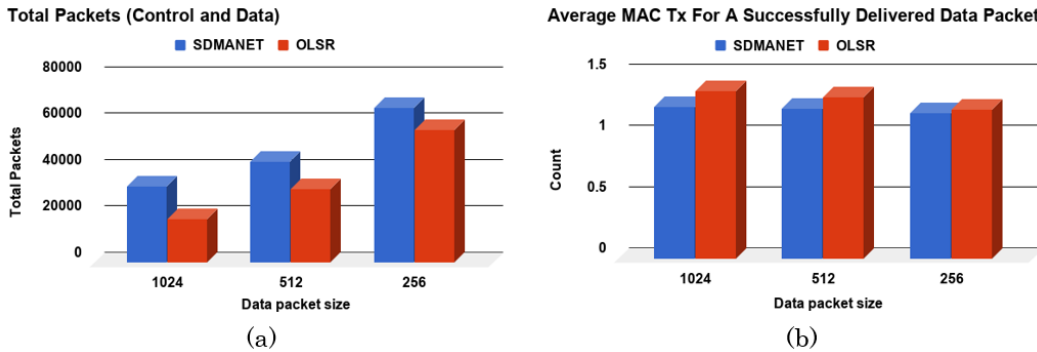

Fig. 20 a) Total packets in the network and b) average MAC transmissions for a successfully delivered data packet

In SD-MANET, large (1024 bytes) data packets cause fewer collisions due to the unicast nature and small size of control packets. Fewer collisions require fewer MAC layer retransmissions of data packets, allowing for a smaller Ae2eD in the network. However, as the data packet size is decreased, the total number of packets (control and data) increase, which keeps the wireless channel busy most of the time and also increases the Ae2eD. A comparison of the increase in the total number of packets in the network with the decrease in data packet size is shown in Fig. 20a.

5.5 Low Node Density

The network node density is decreased by increasing the size of simulation area and randomly allocating nodes in rectangular areas 700×700 m, 800×800 m, 900×900 m, and 1000×1000 m. Figure 21 shows the results.

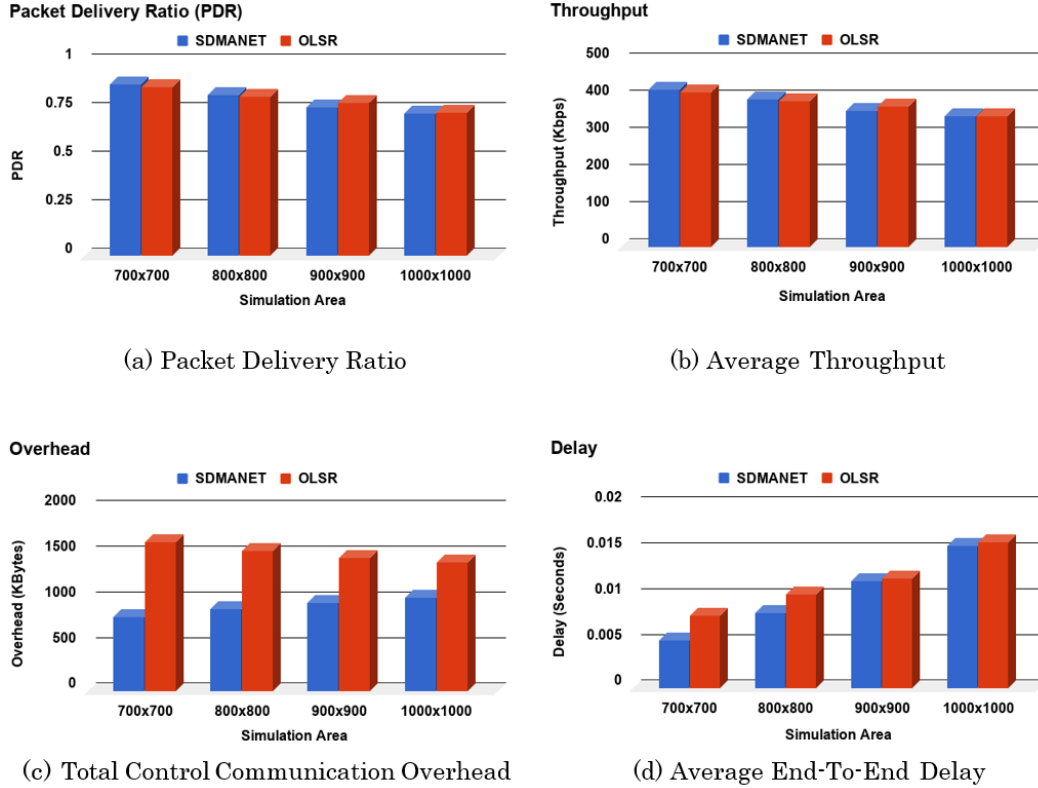

Fig. 21 Simulation results for a network with low node density

- The PDR and the AT decrease with decreasing node density for both SD-MANET and OLSR, but the overhead increases for the same scenario in SD-MANET. It is due to control messages (RUM from the SDNC to nodes, and NIM from nodes to SDNC) being forwarded more times in a scattered network than in a denser one.
- In OLSR, the overhead decreases with the decrease in node density, as each node has fewer neighbor nodes in a scattered network than a denser one; hence, the size of the Hello message reduces as it has the neighbor information. Figure 22a compares the average sizes of control messages in SD-MANET and OLSR. The NDM, RUAM, and LEM of SD-MANET always have the same size, so they are not shown.
- The sizes of the Hello message and NIM decrease with decreasing node density, resulting in lower control communication overhead. However, the NIMs are forwarded by the intermediate nodes to the SDNC, so more such nodes in a scattered network result in more transmissions and an increase in control communication overhead.
- The RUM size increases with decreasing node density because of the encapsulation approach used for sending forwarding information. The RUM

sent to the node encapsulates it such that all the nodes, to which the given node has the same next hop node, are included as a list (containing destination nodes and common next hop node). This reduces the total number of tuples in the RUM forwarding information. When the nodes are scattered in a larger area, there are only a few destination nodes with the common next hop node, so an RUM includes more tuples and this increases the RUM size. Also, an RUM is forwarded more times in a scattered network, which further increases the overhead in the network.

- The increase in the end-to-end delay is due to an increase in the average length of the route. Figure 22b compares the increase in the average number of times a data packet is forwarded to the network with increased simulation area.

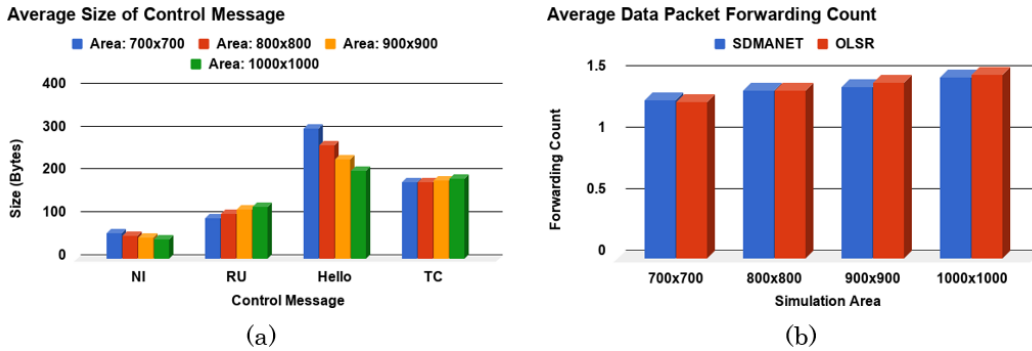

Fig. 22 a) Size distribution of control messages with increase in simulation area and b) average number of time a data packet is forwarded in the network

6. Conclusions

In this report, we presented a proactive routing protocol for SDN-based MANET architecture. Since OpenFlow messages may be inappropriate for a collision-prone high-interference network with unreliable wireless communication links, we designed a new centralized routing protocol and control messages using the format specifications described in Clausen et al.¹⁴

- In this protocol the SDNC learns the network topology without using any of the location services.
- The SDNC establishes network routes for forwarding data packets and sends route updates to all the nodes in the network.

We evaluated the routing protocol extensively in various network scenarios. It was found that the packet delivery ratio and throughput in SD-MANET are comparable with those in OLSR for small (approximately 50 nodes) and low-density networks,

but significant improvements are obtained in reducing the total control communication overhead and average end-to-end delay. However, the performance of SD-MANET starts to degrade when the network size, the node speed, or the interference is increased in the network. This is expected in a centralized architecture for a large MANET due to the issues of scalability and latency.

The benefits of SDN can be leveraged using a single SDNC in a challenging MANET environment for networks of size up to 50 nodes. Scalability issues are well-known in MANET, and several solutions have been proposed in the literature based on either clustering schemes or hierarchical architectures. In most of these solutions, the network is partitioned into multiple domains, where inter- and intra-domain routing is configured separately. A similar approach will be applied in the future to a larger multi-domain SD-MANET network with each domain having its own SDNC.

7. References

1. McKeown N, Anderson T, Balakrishnan H, Parulkar G, Peterson L, Rexford J, Shenker S, Turner J. OpenFlow: enabling innovation in campus networks. *ACM SIGCOMM Computer Communication Review*. 2008;38(2):69.
2. Doria A, Hadi Salim J, Haas R, Khosravi H, Wang W, Dong L, Gopal R, Halpern J. Forwarding and control element separation (ForCES) protocol specification; 2010 Mar. Fremont (CA): Internet Engineering Task Force (IETF). Request for Comments (RFC) 5810.
3. Dely P, Kassler A, Bayer N. OpenFlow for wireless mesh networks. *Proceedings of 20th International Conference on Computer Communications and Networks*; 2011. p. 1–6.
4. De Gante A, Aslan M, Matrawy A. Smart wireless sensor network management based on software-defined networking. *Proceedings of the 27th Biennial Symposium on Communications, QBSC 2014*; 2014 June; Kingston, ON, Canada. p. 71–75.
5. Wang J, Miao Y, Zhou P, Shamim Hossain M, Mizanur S. A software defined network routing in wireless multi-hop network. *Journal of Network and Computer Applications*. 2016;85(C):76–83.
6. Yu HC, Quer G, Rao RR. Wireless SDN mobile ad hoc network: from theory to practice. *Proceedings of the 2017 IEEE International Conference on Communications, ICC 2017*; 2017 May; Paris, France. p. 1–7.
7. Doshi B, Cansever D, Pilipovic J. Software-defined networking for Army's tactical network: promises, challenges, architectural approach, and required S & T work; 2016. Unpublished paper.
8. Ku I, Lu Y, Gerla M, Gomes RL, Ongaro F, Cerqueira E. Towards software-defined VANET: architecture and services. *Proceedings of the 13th Annual Mediterranean Ad Hoc Networking Workshop, MED-HOC-NET 2014*; 2014 June; Piran, Slovenia. p. 103–110.
9. Ku I, Lu Y, Gerla M. Software-defined mobile cloud: architecture, services and use cases. *Proceedings of 10th International Wireless Communications and Mobile Computing Conference*; 2014 Aug; Nicosia, Cyprus. p. 1–6.
10. Truong NB, Lee GM, Ghamri-Doudane Y. Software-defined networking-based vehicular ad hoc network with fog computing. *Proceedings of the 2015 IFIP/IEEE International Symposium on Integrated Network Management*; 2015 May; Ottawa, Canada. p. 1202–1207.

11. Zhu M, Cao J, Pang D, He Z, Xu M. SDN-based routing for efficient message propagation in VANET. In: Xu K, Zhu H, editors. *Wireless algorithms, systems, and applications (WASA)*. Basel (Switzerland): Springer; 2015. p. 788–797.
12. He Z, Cao J, Liu X. SDVN: enabling rapid network innovation for heterogeneous vehicular communication. *IEEE Network*. 2016;30(4):10–15.
13. Correia S, Boukerche A, Meneguette RI. An architecture for hierarchical software-defined vehicular networks. *IEEE Communications Magazine*. 2017;55(7):80–86.
14. Clausen T, Dearlove C, Dean J, Adjih C. Generalized Mobile Ad Hoc Network (MANET) packet/message format. Fremont (CA): Internet Engineering Task Force (IETF); 2009 Feb. Request for Comments (RFC) 5444.
15. L'Ecuyer P, Simard R, Chen EJ, Kelton WD. An object-oriented random-number package with many long streams and substreams. *Oper Res*. 2002;50(6):1073–1075.
16. Friis HT. A note on a simple transmission formula. *Proceedings of the Institute of Radio Engineering*. 1946;34(5):254–256.

List of Symbols, Abbreviations, and Acronyms

ACK	Acknowledgement Data Network
Ae2eD	average end-to-end delay
APSRs	All Possible Shortest Routes
AT	Average Throughput
CM	Connectivity Manager
CTS	Clear To Send
FD	Forwarding Device
FM	Forwarding Manager
FR	Flow Route
FT	Flow Table
GPS	Global Positioning System
HC	Hop Count
IEEE	Institute of Electrical and Electronics Engineers
LC	Local Controller
LEM	Link Error Message
MAC	Media Access Control
MANET	Mobile Ad hoc Network
ND	Neighbor Discovery
NDM	Neighbor Discovery Message
NI	Neighbor Information
NIM	Neighbor Information Message
NL	Neighbor List
OLSR	Optimized Link State Routing Protocol
PDR	Packet Delivery Ratio
QoS	quality of service
RST	Route Settling Time

RSU	roadside unit
RTS	Route-to-SDNC
RU	route update
RUAM	Route Update Acknowledgment Message
RUM	Route Update Message
SD-MANET	Software-Defined Mobile Ad hoc Network
SDN	Software-Defined Networking
SDNC	Software-Defined Networking Controller
SN	Sequence Number
TCCO	Total Control Communication Overhead
TNDM	Triggered Neighbor Discovery Message
TM	Topology Manager
UDP	User Datagram Protocol
WNA	Wireless Network Adapter

1 DEFENSE TECHNICAL
(PDF) INFORMATION CTR
DTIC OCA

2 DIR ARL
(PDF) IMAL HRA
RECORDS MGMT
RDRL DCL
TECH LIB

1 GOVT PRINTG OFC
(PDF) A MALHOTRA

1 ARL
(PDF) RDRL CIH S
V MISHRA