



ARL-TN-0911 • SEP 2018



Testing of Michell-like Trusses

by Robert P Kaste and David M Gray

Approved for public release; distribution is unlimited.

NOTICES

Disclaimers

The findings in this report are not to be construed as an official Department of the Army position unless so designated by other authorized documents.

Citation of manufacturer's or trade names does not constitute an official endorsement or approval of the use thereof.

Destroy this report when it is no longer needed. Do not return it to the originator.



Testing of Michell-like Trusses

by Robert P Kaste and David M Gray
Weapons and Materials Research Directorate, ARL

REPORT DOCUMENTATION PAGE

*Form Approved
OMB No. 0704-0188*

Public reporting burden for this collection of information is estimated to average 1 hour per response, including the time for reviewing instructions, searching existing data sources, gathering and maintaining the data needed, and completing and reviewing the collection information. Send comments regarding this burden estimate or any other aspect of this collection of information, including suggestions for reducing the burden, to Department of Defense, Washington Headquarters Services, Directorate for Information Operations and Reports (0704-0188), 1215 Jefferson Davis Highway, Suite 1204, Arlington, VA 22202-4302. Respondents should be aware that notwithstanding any other provision of law, no person shall be subject to any penalty for failing to comply with a collection of information if it does not display a currently valid OMB control number.

PLEASE DO NOT RETURN YOUR FORM TO THE ABOVE ADDRESS.

1. REPORT DATE (DD-MM-YYYY) September 2018		2. REPORT TYPE Technical Note		3. DATES COVERED (From - To) July 2016–May 2018	
4. TITLE AND SUBTITLE Testing of Michell-like Trusses				5a. CONTRACT NUMBER	
				5b. GRANT NUMBER	
				5c. PROGRAM ELEMENT NUMBER	
6. AUTHOR(S) Robert P Kaste and David M Gray				5d. PROJECT NUMBER	
				5e. TASK NUMBER	
				5f. WORK UNIT NUMBER	
7. PERFORMING ORGANIZATION NAME(S) AND ADDRESS(ES) US Army Research Laboratory ATTN: RDRL-WMM-B Aberdeen Proving Ground, MD 21005				8. PERFORMING ORGANIZATION REPORT NUMBER ARL-TN-0911	
9. SPONSORING/MONITORING AGENCY NAME(S) AND ADDRESS(ES)				10. SPONSOR/MONITOR'S ACRONYM(S)	
				11. SPONSOR/MONITOR'S REPORT NUMBER(S)	
12. DISTRIBUTION/AVAILABILITY STATEMENT Approved for public release; distribution is unlimited.					
13. SUPPLEMENTARY NOTES					
14. ABSTRACT In support of projects to examine the behavior of Michell-like trusses conducted by Lieutenant Colonel Curtis L Decker, working for the US Army Research Laboratory's (ARL) Materials Response and Design Branch (MRDB), and on topological optimization conducted by Andrew T Gaynor (ARL/MRDB), this report describes the fixture used to test these trusses, along with procedures used to enhance the performance of the fixture and recommendations to further improve the fixture. Difficulties encountered in the testing and procedures used to perform the testing are discussed. The use of digital image correlation and resistive-type strain gauges to measure strain in the trusses is detailed, along with discussion on why the results from the two techniques vary.					
15. SUBJECT TERMS Michell truss, DIC, strain, digital image correlation, buckling					
16. SECURITY CLASSIFICATION OF:			17. LIMITATION OF ABSTRACT UU	18. NUMBER OF PAGES 30	19a. NAME OF RESPONSIBLE PERSON David M Gray
a. REPORT Unclassified	b. ABSTRACT Unclassified	c. THIS PAGE Unclassified			19b. TELEPHONE NUMBER (Include area code) (410) 306-0852

Standard Form 298 (Rev. 8/98)
Prescribed by ANSI Std. Z39.18

Contents

List of Figures	iv
Acknowledgments	v
1. Background	1
2. Introduction	1
3. Strain Gauges	4
4. Fixture Description	7
5. Testing	11
6. Recommendations for the Fixture	12
7. Initial Testing	13
8. Out-of-Plane Brace	15
9. Fabrication of Specimen	17
10. Joint Designs	17
11. Conclusion	21
12. References	22
Distribution List	23

List of Figures

Fig. 1	Structural steel truss	1
Fig. 2	Instron front-right view.....	2
Fig. 3	Two pairs of cameras	3
Fig. 4	Strain gauge	5
Fig. 5	M42 gauge	6
Fig. 6	Strain data 1	6
Fig. 7	Strain data 2	7
Fig. 8	Setup	8
Fig. 9	Shim washers	9
Fig. 10	Clevis with gauge.....	9
Fig. 11	Load end.....	10
Fig. 12	Shims.....	10
Fig. 13	Stretched anchor hole closer	11
Fig. 14	Setup, closer view	12
Fig. 15	Clevis	13
Fig. 16	Initial testing of the gauges	14
Fig. 17	Out-of-plane brace	16
Fig. 18	Needle nozzle.....	17
Fig. 19	Original joint configuration	19
Fig. 20	TO joint configuration	20
Fig. 21	No-joint configuration	21

Acknowledgments

The authors express their gratefulness to the dedication, skills, and expertise provided by the US Army Research Laboratory/Weapons and Materials Research Directorate's (ARL/WMRD) Experimental Fabrication Shop and the ARL/WMRD Metal Fabrication Shop. In particular, to those listed alphabetically below, thank you:

- Mark Babka
- Jake Brown
- Micah Gallagher
- Bobby Hall
- David Hall
- James Hall
- Thomas Hoerr
- Charlie Kranz
- Bob Reinsel
- Kevin Witkowski
- Rick Workman

Your efforts were essential to the completion and execution of this project.

The authors also recognize and thank Paul Moy and Tim Walter for their guidance and support in the effort of acquiring and collecting data for this project. Additionally, the authors thank Matt Batcher for the use of his torque wrench.

1. Background

LTC Curtis L Decker working for the Materials Response and Design Branch (MRDB) of the US Army Research Laboratory (ARL) conducted a project to examine the behavior of Michell-like trusses.¹ His work along with work by Andrew T Gaynor (ARL/MRDB) in the area of topological optimization (TO) are reported^{2,3} elsewhere and include results and comparisons to theories that are outside the scope of this report.

The intent of this report is to document the efforts made to build and execute the experiments used to collect data for those projects.

2. Introduction

Some cursory information is required to understand the scope and size of this experiment.

Structural steel trusses, with two anchor pins of 1.75-inch diameter located vertically 12 inches apart, were loaded through a load pin of 1.75-inch diameter located 24 inches horizontally from the anchor pins at their vertical midpoint (Fig. 1).

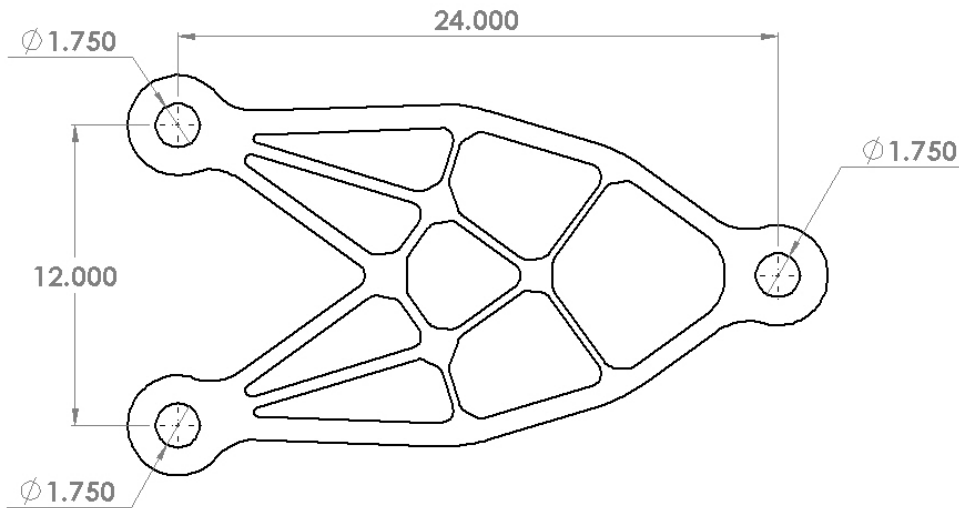

Fig. 1 Structural steel truss

The fixture restraining the anchor pins was mounted to the base of an Instron 5500R 1127 load frame⁴ and was also supported through a stand to the floor (Fig. 2). The load pin was displaced by the load frame through a 50-kip load cell attached to the load frame. A specially designed clevis was mounted to the load cell that allowed

some horizontal motion of the load pin as the specimen deformed without creating undue transverse loading to the load cell. Displacement control was used at an upward rate of 0.05 inches/min. The Blue Hill2 software⁴ controlling the load frame was set to limit the load to 45 kip or typically 1.75-inch extension, whichever occurred first. In all cases but the 1.25-inch thick specimen, M31, the extension limit ended the test. In one early test, the frame was allowed to extend to 2.5 inches. This created problems in extracting the deformed specimen after testing as the allowance for horizontal displacement within the clevis was totally consumed when the load was removed. The decision to limit the extension to 1.75 inches was based on this occurrence.



Fig. 2 Instron front-right view

Two pairs of PointGrey 2.3-megapixel cameras⁵ with 50-mm lenses were used to collect data for digital image correlation (DIC), as shown in Fig. 3. Two Genaray SpectroLED lamps⁶ were used to illuminate the specimen. In initial testing, a single pair of cameras and 80-mm lenses were used but this proved inadequate in providing sufficient strain resolution to observe strain approaching and at yield (about 0.015 strain). The dual system of two pairs of cameras provided image capture of a little more than half of the specimen by each pair. A slight overlap provided complete coverage of the specimen that could be postprocessed and combined to produce a complete, aligned image of the entire specimen. The dual system produced von Mises strain output discernable to about 0.005 strain.

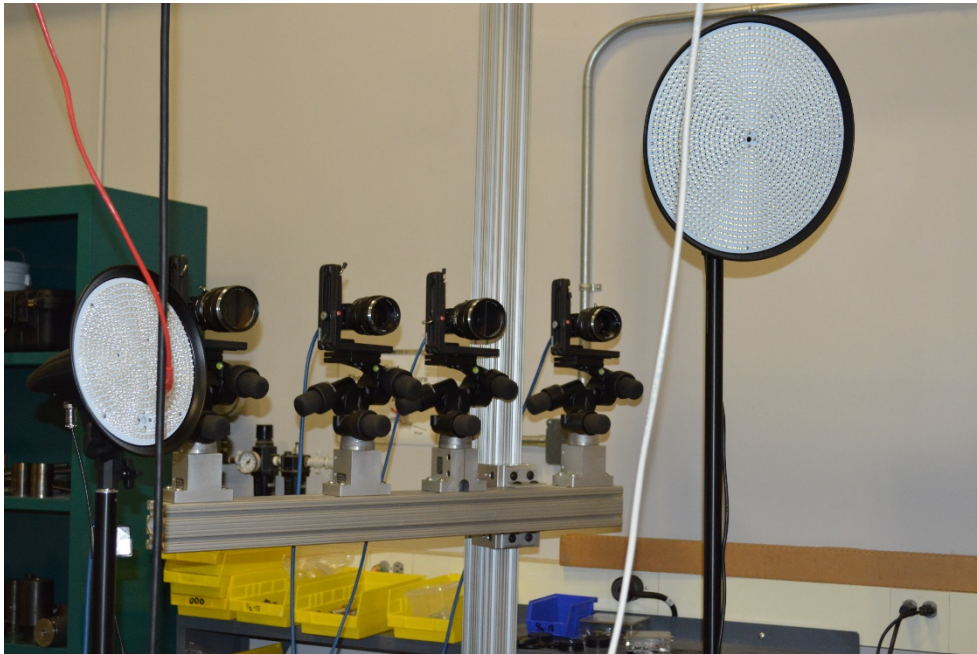

Fig. 3 Two pairs of cameras

VIC-SNAP 8 software⁷ was used to collect and synchronize the images from the cameras at a rate of one image per second on all four cameras. Settings within VIC-SNAP 8 designated each camera in respect to system and camera number. VIC-3D 7 software⁷ was used to analyze the image data collected and produce numerical and graphical outputs of the calculated strains. Typically, a subset of 9 and a step size of 7 was used to correlate the regions of the members that typically varied from about 0.375-inch to about 0.875-inch wide. In some tests with more narrow members and later tests with the out-of-plane brace that was 0.5-inch wide, it was necessary to reduce the step size to 5 to facilitate correlation of members of these widths. In addition to tracking the motion of the speckle pattern on the trusses, various speckled flags were placed on the fixture to capture the motion of the anchor plates, I-beam, and clevis. Analog data from the Instron 1127 were exported

and captured by the VIC-SNAP 8 software to provide synchronized machine extension and load data.

3. Strain Gauges

Because the relatively low levels of strain, the onset of yielding, and the manner in which yielding progressed through the trusses were of interest, DIC was used to measure strain. However, it was somewhat of a challenge to measure small strains throughout an area over 2 ft² in size. As stated previously, two pairs of camera systems were used to provide strain data over the area of the trusses with marginally sufficient resolution to observe the onset of yield. It was decided to use some resistance-type strain gauges to more precisely monitor strains on the trusses. In one case, where the behavior of the truss, a non-Michell-like truss, was not well understood prior to testing, four pairs of perpendicular gauges were placed on locations believed to be sites for initial yielding. The truss did not behave as anticipated; the locations of the gauges turned out to be in areas of lesser interest, with very low strain.

The DIC strains were found to be in the x and y directions in the reference coordinated system of the cameras. Strain gauges, Micro-Measurements CEA-13-125WT-350 devices,⁸ were attached to the truss in the same orientation (Fig. 4). However, as the truss deforms, the orientation of the gauges moves accordingly. Therefore, coordinate correction must be applied to properly compare the strains measured by the two different techniques depending on the motion of the deformed truss. The strains measured in this first case were very low, in the lower limit of the DIC system to calculate strain. There was, however, good agreement even at this level of strain (around 0.005 measured via DIC) with that measured by the strain gauges, which had a vastly superior signal-to-noise ratio.



Fig. 4 Strain gauge

Next, a second truss was strain gauged. Gauges were glued on at five locations, as depicted in the schematic in Fig. 5. Data from the DIC system and the strain gauges generally correlated well. Differences occurred when DIC correlation was lost at a gauge location; however, the strain gauge data largely agreed well with the calculated strain from the DIC. In some cases, the gauge-measured strains were greater than the DIC strains. If the area of the truss became less aligned to the original x-y coordinate system, this would be expected (as per the strain data in Figs. 6 and 7). The strain from the gauges was measured using a Vishay model 6100 scanner⁹ and recorded using StrainSmart software.⁹ Load and extension from the Instron 1127 were also recorded on this system, providing a means to synchronize these strain data with the loading and DIC data.

M42 Strain Gauge Legend

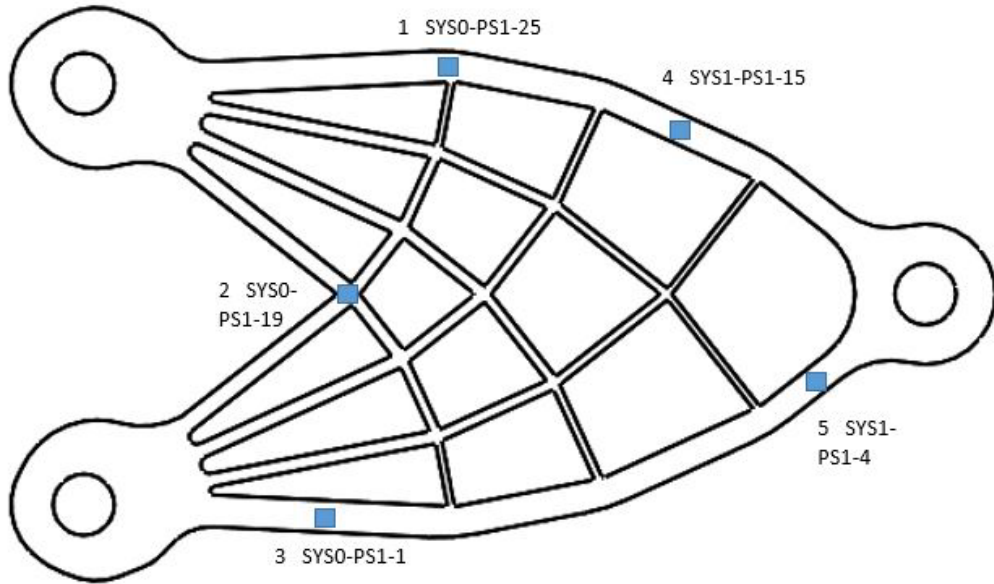

Fig. 5 M42 gauge

Truss Strains and Load Area with little rotation

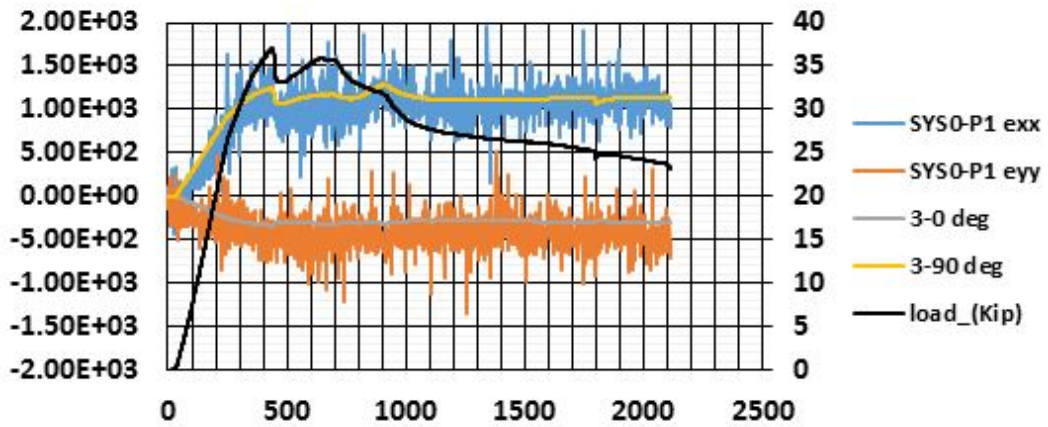

Fig. 6 Strain data 1

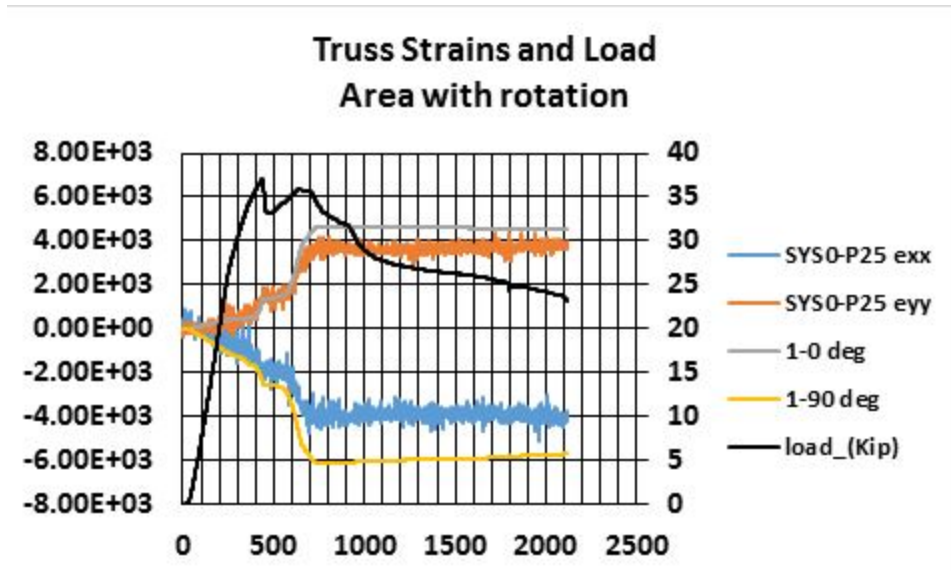

Fig. 7 Strain data 2

4. Fixture Description

The fixture was designed by LTC Decker and Mr Kaste. The ARL/Weapons and Materials Research Directorate (WMRD) Experimental Fabrication and Metal Fabrication Shops fabricated all the components of the fixture. The W27-178 I-beam and other structural steel stock were purchased and modified. A 96-inch-long section of W27-178 I-beam was the major component of the fixture (Fig. 8). A 24-inch section of W27-178 beam served as the mount for two 20.5- × 6- × 2-inch anchor plates. The mount, the shorter section of I-beam, was modified with reinforcement flanges and holes and was welded onto a 39- × 14-inch plate, 2 inches thick with slots to allow adjustment in interfacing trusses to the Instron.

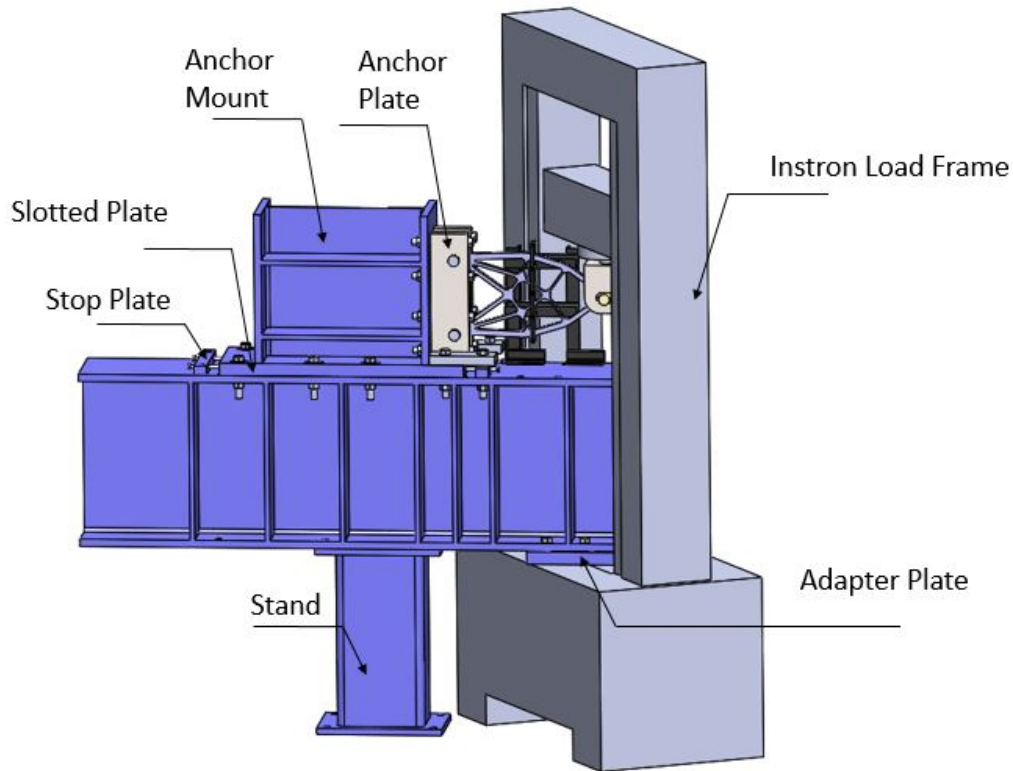

Fig. 8 Setup

The main section of I-beam was modified with mounting holes and reinforcement flanges welded to the top and bottom flanges and the central web on both sides. Holes allowed mounting of the specimen mount, stop blocks to secure the axial location of the mount, a stand that went to the floor, and an adapter plate used as a tie-down to the Instron load frame. Holes in the anchor plates allowed pinning the specimen to the fixture via 1.75-inch-diameter pins. Shim washers (Fig. 9) were used between the anchor plates and specimen to restrict sideway motion of the anchor sections of the specimen. A 1.75-inch pin also was used to load the specimen through a clevis mount attached to the Instron load cell. The clevis was slotted to accommodate about 0.5-inch movement in the transverse direction due to deformation in the specimen. Likewise, the specimen was not restricted to movement axially with the pin (Figs. 10 and 11). These two degrees of freedom reduced crosswise loading to the load cell, which is not designed to carry transverse loading. The fixture was constructed to be at a 30° angle with the Instron load frame to facilitate optical access of the mounted trusses for the purpose of DIC. Bolts used throughout the fixture were grade 8. The pins and clevis were heat treated to 140-kpsi yield strength.



Fig. 9 Shim washers



Fig. 10 Clevis with gauge

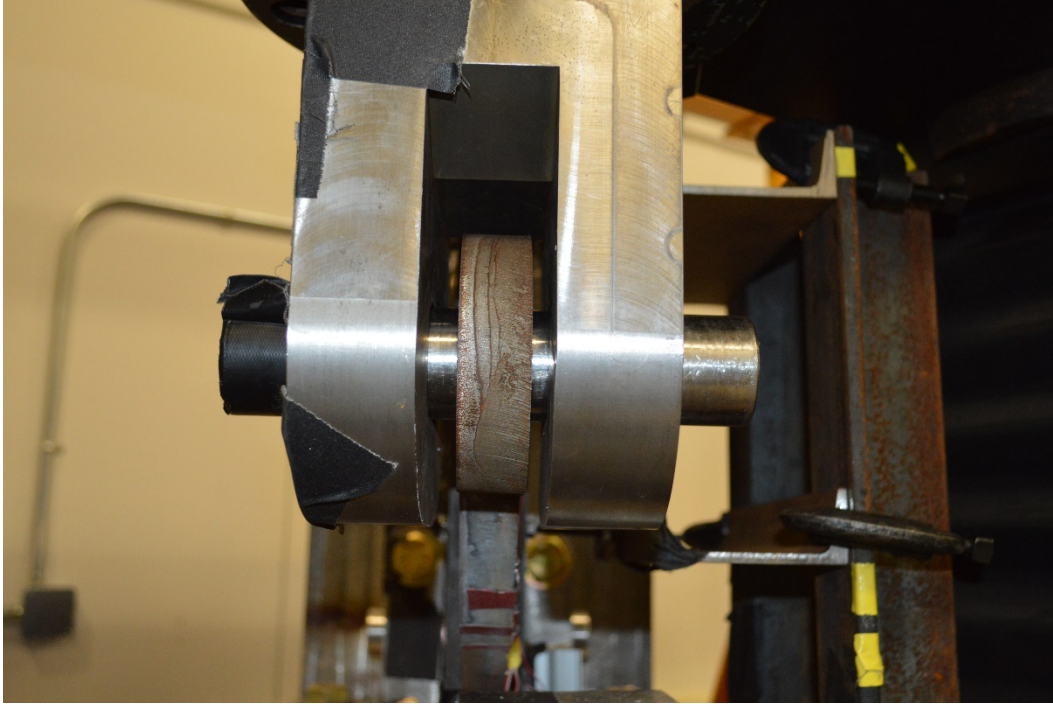

Fig. 11 Load end

It was determined after assembly that the top surface of the I-beam was not parallel to the floor or Instron base. To align the truss with the Instron, one side of the mounting fixture was shimmed up about 0.25 inch from the I-beam (Fig. 12).



Fig. 12 Shims

Approved for public release; distribution is unlimited.

5. Testing

Deformations localized at the specimen anchor ears (Fig. 13) in early tests prevented the removal of the lower anchor pin from the anchor plate while the anchor plates were still attached to the fixture. Removal of the anchor plates, with the specimen still attached, allowed for removal of the stuck pin via an arbor press. The inconvenience of this was the cause for increasing the amount of material in the ears so that such deformation would not occur. It should be noted that tight tolerances were held between the pins and holes in the anchor plates and trusses. Because of the tight tolerances, the anchors were bolted to the fixture rather than welded on to facilitate mounting and removal of the trusses. Due to the tight tolerances of the fixture, holes, and pins, it was necessary to assemble the specimen via the pins to the anchor plates while the attachment bolts were loose and then tighten the bolts. Likewise, it was necessary to loosen the attachment bolts to permit the removal of the pins and specimen after testing. Note, the 1-inch-diameter tie-down bolts and nuts (six on each side) attaching the anchor plates to the fixture were torqued to around 700 ft-lbf for testing. The torque applied to the anchor bolts were checked with a CDI Torque Products, model 10005MFRMH, 1,100-ft-lbf torque wrench.



Fig. 13 Stretched anchor hole closer

It should also be noted that Gaynor et al.³ used TO to produce improved anchor end designs that greatly reduced the localized deformations of the anchor holes, which previously hindered the removal of the tested trusses from the fixture. These improved ends were typically used where the number of members and junction design were the variables tested. A set of tests where only the ears were different was performed. The TO ears and a design with lesser material at the ear resulted in very similar results, revealing that this localized yielding at the anchor hole had little effect on the overall behavior of the truss under loading.

6. Recommendations for the Fixture

If this test fixture were to be replicated, it would be advantageous to extend the length of 2-inch-thick plate that attaches the specimen mount to the I-beam (Fig. 14). Extending this plate toward the load point would reduce the bending of the I-beam top flange and reduce the movement of the anchors. The extra reinforcements added to the I-beam and tie-down extensions welded onto the anchor plates compensated somewhat for what a longer plate would have achieved.

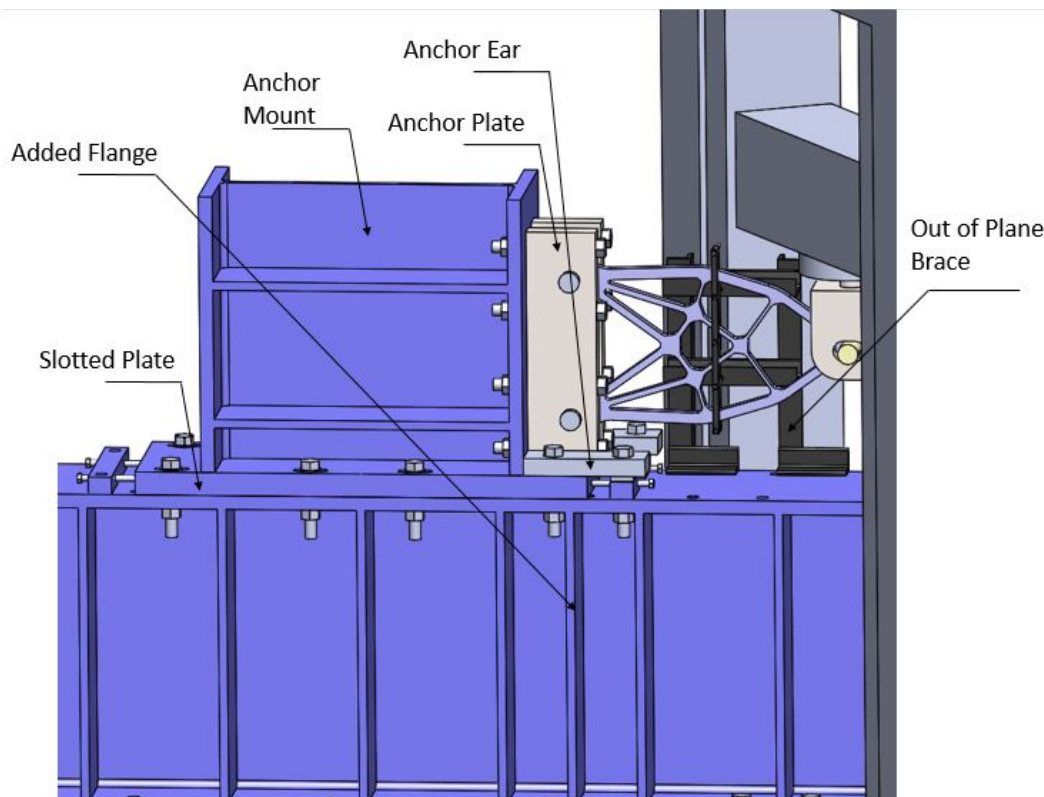

Fig. 14 Setup, closer view

The limited free space of the load frame test area, specimen volume, fixture height, force train, and anchor pins needs to be considered when applying suggested modifications.

Additionally, the clevis attachment for the load pin as fabricated (Fig. 15) may be too restrictive for specimens that are taller in the load point region than those we tested. This restrictiveness could easily be overcome with a clevis redesign. However, it is also necessary to use hardware that meets the free space and stack up needs for the specimen and load frame used.

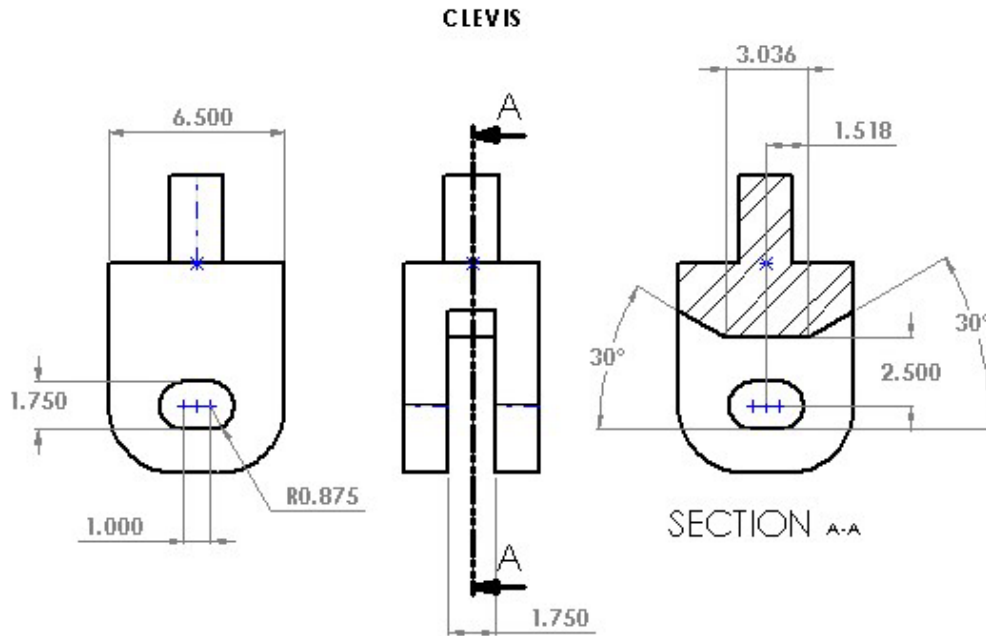

Fig. 15 Clevis

7. Initial Testing

Using the 1.25-inch-thick, 3-member truss, a single DIC system was used to observe the deformation of the truss and motion of the fixture to which the frame was attached. The motion at the anchor plate's attachment points was observed to be about 0.040 inch vertically. This was considered undesirably large, as the ideal case would be no motion at the anchors. It was also observed that the 1.25-inch-thick truss had no significant or permanent deformation by loading the truss up to 45 kip. Therefore, a series of tests were performed where the torquing of tie-down bolts was increased to about 350 ft-lbf and various locations on the fixture were monitored with dial indicators to determine what moved and the influences on the movement of the anchors (Fig. 16).



Fig. 16 Initial testing of the gauges

Ultimately, it was determined that there were three dominant actions that influenced the motion of the anchors: the motion of the anchor plates relative to the I-beam, the lifting of the stand from the floor, and the flexure of the I-beam's upper flange. These motions could be reduced through three actions: 1) welding the ears onto the anchor plates so they could be bolted down to the I-beam (previously they were cantilevered, mounted to the fixture with four bolts on each side; see Fig. 14); 2) moving the stand closer to the Instron to change the reaction loads (see Fig. 8); and 3) welding additional flanges to the I-beam to tie the top and bottom flanges together to the vertical web (see Fig. 14).

Note that, as mentioned in Section 6, lengthening the 2-inch-thick slotted plate would redistribute the load and change the reaction on the fixture, thereby eliminating the localized bending of the top flange of the I-beam. As built and with the particular length of the trusses ultimately tested, the loading of the anchor plates was mid-span of the original reinforcement flanges. Fortunately, an additional flange could be added to stiffen the I-beam and allow the use of the original bolt pattern.

Thanks to Jake Brown, of the ARL/WMRD Experimental Fabrication shop, installation of these additional flanges was accomplished with the fixture assembled and mounted in the testing configuration.

The lift off the floor of about 0.015 inch at 45 kip was changed to a downward movement of about 0.005 inch at 15 kip and then maintained solid against the concrete floor through the relocation of the stand.

The addition of the tie-down ears and stiffening of the I-beam had two influences. The lifting of the anchor plates was reduced from about 0.007 inch to about 0.004 inch. The lifting of the I-beam flange was reduced from about 0.018 inch to about 0.005 inch.

By adding the reinforcement flanges and tie-down ears, and relocating the stand, the motion of the anchors was reduced from about 0.040 inch to about 0.020 inch, a 50% reduction.

The effect of stiffening the fixture by relocating the stand and reducing the movement of the anchors relative to the I-beam and the motion (flexure) of the top I-beam flange netted about a 13% increase in measured effective stiffness for the 1.25-inch-thick, 3-member truss.

Note that when the added I-beam flanges were initially installed, they were not welded with a heavy continuous seam on all surfaces (inside top and bottom flanges and web). Testing with this configuration resulted in the cracking of the welds. Subsequently, the welds were repaired, and made heavy and continuous. These improved welds were observed and did not crack.

8. Out-of-Plane Brace

From the onset of this project, there was concern about out-of-plane buckling. Special care was made in designing the specimen so as to limit this tendency. Initial testing of three thicknesses of specimen was made to examine this. Identical specimen shapes were water-jet cut from 1.25-, 1.00-, and 0.75-inch-thick plates.

The results of testing these revealed that the 1.25-inch specimen could not be deformed by the 45-kip load provided by the Instron load frame. The 1.00-inch specimen buckled in plane and the 0.75-inch-thick one buckled out of plane. Unbeknownst at the time, the 1.25-inch one was not cut from a plate of structural steel but was of a higher strength steel. Based on the initial results, however, it was decided to make further specimen from 1.00-inch-thick plate as this seemed to be adequate in regard to out-of-plane buckling. Unfortunately, as testing proceeded, roughly 50% of the specimen testing resulted in out-of-plane buckling. A brace was designed to provide support and reduce the tendency for out-of-plane buckling. The brace consisted of a two lengths of 1/2-inch-square steel bar bolted together with spacers between them to provide some clearance (nominally 0.015 inch) with the

specimen. The brace was attached via 1/4-inch threaded rods to a heavy C-channel attached to a heavy EL channel attached to the Instron load frame (Fig. 17).



Fig. 17 Out-of-plane brace

This arrangement did prevent specimen from buckling out of plane. There were, however, varying degrees of interference of the brace in the testing. Typically, the top member, under compression, would deform. This deformation would cause a slight localized thickening of the member that created interference with the brace. The brace would then move with the specimen, motion it was not designed to endure, resulting in bending of the 1/4-inch threaded attachment rods. The amount of force to bend these rods is small, however, compared to the overall loading on the specimen (around 40 kip). In some cases, the brace was only stuck to the specimen in one place. In other cases, there was interference in multiple locations,

resulting from perhaps more localized bending or possibly from the resistance applied to limit of out-of-plane buckling.

9. Fabrication of Specimen

Typically, SolidWorks was used to produce a 3-D parts with desired specimen features. DXF files were generated from these parts and provided to the ARL Metal Fabrication Shop who adapted them as input to the water-jet cutter and cut the shapes from steel plate. The holes for the mounting and loading pins were machined into the cut specimen afterward by the Experimental Fabrication Shop. The specimen were sanded with 80-grit sandpaper and cleaned with acetone in preparation for painting. Speckle patterns were produced by spray painting the specimen white and then “misting” them with black spray paint. The misting was facilitated by using a needle nozzle on the black paint can (Fig. 18). Both paints were of a flat finish. The attachment holes were masked to keep paint off of these surfaces.



Fig. 18 Needle nozzle

10. Joint Designs

True Michell trusses are pinned. The designs tested are Michell-like in that the member intersections are based on the Michell theory. The tested specimen are one piece, cut from a sheet of steel. Other design criteria are used to determine the width of the members particularly in consideration of the thickness of plate. This one-piece design creates the need to design an interface at the joining members that is not considered in the theory.

In this study, three primarily different junction considerations were implemented:

- 1) Members with a primarily rectangular cross sections and a generous blend. This was considered the “original junction”.
- 2) Junctions based on TO-based designs.
- 3) So-called “no joint” junctions. It is recognized that creating members that connect with sharp edges is undesirable, so a small radius (0.0625-inch) blend joins the members at their intersections.

The techniques used to determine the junctions are described below.

For the original junctions, Fig. 19 shows the features of this construction, members with primarily rectangular cross sections:

- 1) A radius was chosen, typically 0.375 or 0.5 inch.
- 2) Beginning at the center of the truss, the radius was inserted at the junction of the symmetric members.
- 3) A line was drawn from the end of the tangentially blended radius perpendicular across the member.
- 4) An arc was drawn from the edge of the member to the edge of the adjacent member.
- 5) A line was drawn from the midpoint of the arc to the virtual intersection of the two edges.
- 6) A line perpendicular to this line was drawn.
- 7) A blend of the chosen radius was made from the point determined by perpendicularity of the previous radius, to the line perpendicular to the line through the arc midpoint.
- 8) A blend was also made at the other end of the perpendicular line, establishing the intersection at the next member.
- 9) A line was drawn from this point perpendicularly across this member.
- 10) This process was repeated until all internal junctions were blended.
- 11) At the load point end, the minimum radius that would leave material at a 2-inch radius from the center of the hole was used between the two members.

- 12) The outer surface radii were chosen such that the members had rectangular cross sections based on the length determined by the internal blends.
- 13) Smaller radius blends, typically 0.25 inch, were used to join the members leading to the anchor ends. Other radii were used to establish rectangularity of these members.
- 14) Various outside radii were used at the anchor ends depending on the variant of end in use.

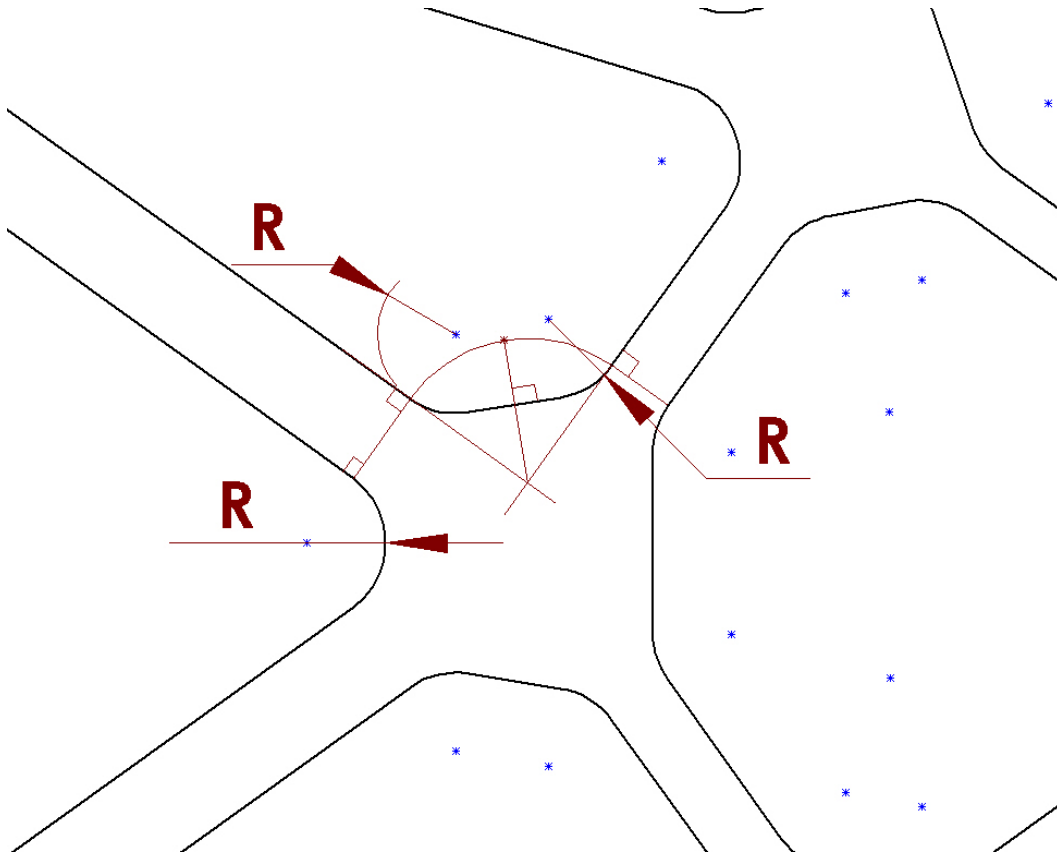

Fig. 19 Original joint configuration

TO was run to determine shapes for the joining of the members. An approximation of these shapes was determined and used in SolidWorks to facilitate design and fabrication of the trusses.

Construction of these, topologically optimized junctions was done using the following method. This design of junctions also kept primarily rectangular cross sections of the members. Figure 20 shows the following features of this construction:

- 1) Through observation, the blend radii were determined to be about 0.125 inch and located about 0.300 inch from virtual intersection of the two edges. This radius and location were chosen.
- 2) On the symmetric junction, the end of the blend was about 0.6 inch from the virtual intersection.
- 3) An arc of 0.125 radius was located 0.3 inch from the virtual intersection.
- 4) To mimic the interface like that generated by the TO, lines were drawn from the ends of the arc that were at 2° outward from the member edge.
- 5) These lines were then continued with two tangent curves to bring closure of the curve generated at the point 0.6 inch from the virtual corner. All segments of this curve, whether arc or linear, are continuously tangent.
- 6) A line from the endpoint of the curve with the straight edge of the member, perpendicular to this edge defines the end point for the curve of the adjacent blend. In this manner, as in the original junctions, predominately rectangular cross sections define the members.
- 7) This technique is continued throughout the truss.
- 8) The outer radii and radii at the ends were determined in a similar manner as used in the “original junction”.

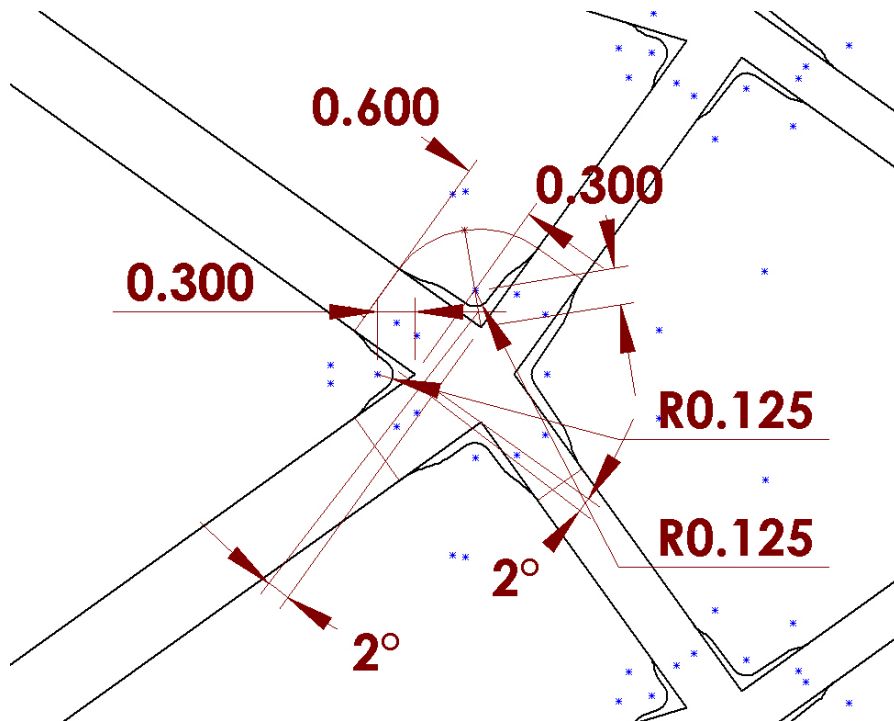

Fig. 20 TO joint configuration

In the so-called no-joint configuration, Fig. 21 shows the features of this construction, a minimal radius (0.0625-inch) was filleted into the connecting edges of the joining members. As can be seen in Fig. 21, this method does not facilitate perpendicular endings of the edges and therefore the cross sections of the linear portions of the members are not rectangular as in the other two junction configurations. Similar radii as used in the previous concepts were used at the connection ends of the truss.

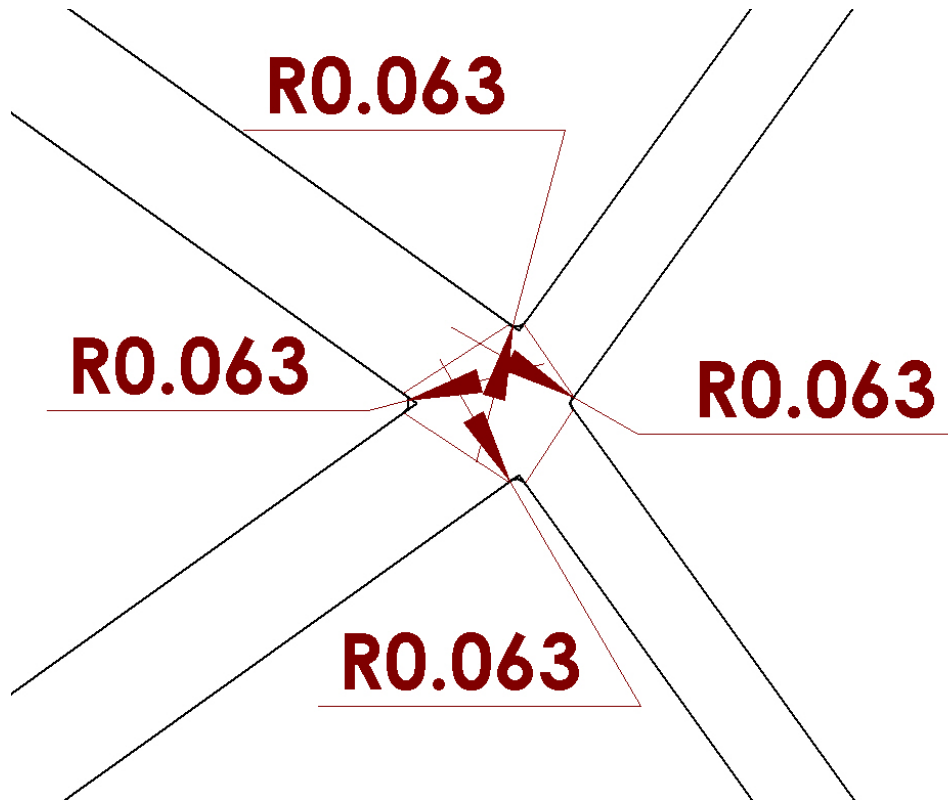

Fig. 21 No-joint configuration

Results of these tests are reported by Decker et al.² and Gaynor et al.³

11. Conclusion

The successful testing of Michell-like trusses was demonstrated using an I-beam fixture design affixed to an Instron 5500R load frame. It was determined that alignment, fixture bolt torque, and out-of-plane bracing plays a major role in the test performance of the truss. The use of DIC and strain gauging techniques allowed strain measurements to be recorded from various regions of the truss during testing. Notable design modifications to the radii and joint sections of the truss resulted in structural performance differences as reported by Decker et al.² and Gaynor et al.³

12. References

1. Martínez P, Martí-Montrull P, Querin O. Growth method for size, topology, and geometry optimization of truss structures. *Structural and Multidisciplinary Optimization*. 2007 Jan;33(1):13–26.
2. Decker CL, Gaynor AT, Albritton SK, Mazurek A, Baker WF. Experimental testing of Michell-like structures. In: Mueller C, Adriaenssens S, editors. *Proceedings of the IASS Symposium 2018, Creativity in Structural Design*; 2018 July 16–20; MIT, Boston, MA.
3. Gaynor AT, Decker CL, Kaste R, Gao T, Mazurek A, Baker WF. Experimentally-informed topology optimization of Michell/Prager structures. In: Mueller C, Adriaenssens S, editors. *Proceedings of the IASS Symposium 2018, Creativity in Structural Design*; 2018 July 16–20; MIT, Boston, MA.
4. Instron home page. Norwood (MA): Illinois Tool Works; n.d. [accessed 2018]. <http://www.instron.us/en-us>.
5. FLIR machine vision. British Columbia (Canada): FLIR Integrated Imaging Solutions, Inc. (formerly PointGrey); 2018 [accessed 2018]. <https://www.ptgrey.com/>.
6. Genaray home page. New York (NY): Genaray; 2018 [accessed 2018]. <http://www.genaray.com/>.
7. Correlated Solutions home page. Irmo (SC): Correlated Solutions; 2018 [accessed 2018]. <http://correlatedsolutions.com/>.
8. Micro Measurements home page. Wendell (NC): Vishay Precision Group, Inc.; 2017 [accessed 2018]. www.vishaypg.com/micro-measurements.
9. Vishay home page. Shelton (CT): Vishay Americas; n.d. [accessed 2018]. www.vishay.com.

1 DEFENSE TECHNICAL
(PDF) INFORMATION CTR
DTIC OCA

2 DIR ARL
(PDF) IMAL HRA
RECORDS MGMT
RDRL DCL
TECH LIB

1 GOVT PRINTG OFC
(PDF) A MALHOTRA

1 ARL
(PDF) RDRL WMM B
D GRAY