



**NAVAL
POSTGRADUATE
SCHOOL**

MONTEREY, CALIFORNIA

THESIS

**A SYSTEMS ARCHITECTURE FOR OPERATIONAL
DISTRIBUTED LETHALITY**

by

Clay I. Johnson

June 2016

Thesis Advisor:
Second Reader:

Eugene Paulo
Paul Beery

~~Approved for public release, distribution is unlimited~~

**Distribution authorized to Department of Defense and U.S. DoD Contractors only;
Administrative or Operational Use; December 2016. Other requests for this
document must be referred to President, Code 261, Naval Postgraduate School,
Monterey, CA 93943-5000 via the Defense Technical Information Center, 8725 John
J. Kingman Rd., STE 0944, Ft. Belvoir, VA 22060- 6218.**

THIS PAGE INTENTIONALLY LEFT BLANK



DEPARTMENT OF THE NAVY
NAVAL POSTGRADUATE SCHOOL
DUDLEY KNOX LIBRARY
411 DYER ROAD, ROOM 110
MONTEREY, CALIFORNIA 93943-5101

NPS (013)
09 Sep 19

From: University Librarian, Naval Postgraduate School
To: DTIC-OQ, Defense Technical Information Center, 8275 John J. Kingman Road, Suite, 0944,
Fort Belvoir, VA 22060-6218

Subj: CHANGE IN DISTRIBUTION STATEMENT FOR AD1060128

1. Request a distribution statement change to:

AD1060128: Johnson, Clay I. A Systems Architecture for Operational Distributed Lethality. Monterey, CA: Naval Postgraduate School, June 2016.

2. Upon consultation with subject matter experts, the Naval Postgraduate School has determined that, effective December 19, 2016, the distribution of this document should be restricted to:

Distribution authorized to Department of Defense and U.S. DoD Contractors only;
Administrative or Operational Use; December 2016.

3. POC for this request is George Goncalves, Librarian, Restricted Resources and Services, 831-656-2061, DSN 756-2061 (gmgoncal@nps.edu).

A handwritten signature in black ink, appearing to read "Tom Rosko", with a long horizontal flourish extending to the right.

THOMAS J. ROSKO



December 20, 2016

SUBJECT: Change in distribution statement for *A systems Architecture for Operational Distributed Lethality* – December 2016

1. Reference: Johnson, Clay I. *A Systems Architecture for Operational Distributed Lethality*. Monterey, CA: Naval Postgraduate School, Systems Engineering Department, June 2016.. UNCLASSIFIED, Approved for public release.
2. Upon consultation with NPS faculty, the School has determined that the distribution on this thesis needs to be restricted to
Distribution authorized to Department of Defense and U.S. DoD Contractors only;
Administrative or Operational Use; December 2016.
effective December 19, 2016.

University Librarian
Naval Postgraduate School

THIS PAGE INTENTIONALLY LEFT BLANK

REPORT DOCUMENTATION PAGE			Form Approved OMB No. 0704-0188	
Public reporting burden for this collection of information is estimated to average 1 hour per response, including the time for reviewing instruction, searching existing data sources, gathering and maintaining the data needed, and completing and reviewing the collection of information. Send comments regarding this burden estimate or any other aspect of this collection of information, including suggestions for reducing this burden, to Washington headquarters Services, Directorate for Information Operations and Reports, 1215 Jefferson Davis Highway, Suite 1204, Arlington, VA 22202-4302, and to the Office of Management and Budget, Paperwork Reduction Project (0704-0188) Washington DC 20503.				
1. AGENCY USE ONLY (Leave blank)		2. REPORT DATE June 2016		3. REPORT TYPE AND DATES COVERED Master's Thesis
4. TITLE AND SUBTITLE A SYSTEMS ARCHITECTURE FOR OPERATIONAL DISTRIBUTED LETHALITY			5. FUNDING NUMBERS	
6. AUTHOR(S) Clay I. Johnson				
7. PERFORMING ORGANIZATION NAME(S) AND ADDRESS(ES) Naval Postgraduate School Monterey, CA 93943-5000			8. PERFORMING ORGANIZATION REPORT NUMBER	
9. SPONSORING /MONITORING AGENCY NAME(S) AND ADDRESS(ES) N/A			10. SPONSORING / MONITORING AGENCY REPORT NUMBER	
11. SUPPLEMENTARY NOTES The views expressed in this thesis are those of the author and do not reflect the official policy or position of the Department of Defense or the U.S. Government. IRB Protocol number ___N/A___.				
12a. DISTRIBUTION / AVAILABILITY STATEMENT Approved for public release, distribution is unlimited Distribution authorized to Department of Defense and U.S. DoD Contractors only; Administrative or Operational Use; December 2016. Other requests for this document must be referred to President, Code 261, Naval Postgraduate School, Monterey, CA 93943-5000 via the Defense Technical Information Center, 8725 John J. Kingman Rd., STE 0944, Ft. Belvoir, VA 22060- 6218.			12b. DISTRIBUTION CODE D	
13. ABSTRACT (maximum 200 words) Distributed Lethality is a new concept in Surface Warfare that involves using small groups of surface combatants to go on the offensive against the enemy. This new concept requires structure and definition, and building a systems architecture for it is an effective way to provide both. This thesis investigates and defines the core requirements of Distributed Lethality and the capabilities that are necessary to meet these requirements. It builds an example mission flow for a Distributed Lethality scenario, and then defines the functions necessary to implement this flow. Finally, the model includes the components that perform the identified functions. The systems architecture for operational Distributed Lethality clearly demonstrates the connections and relationships between each element of the model, allowing for clear traceability from the smallest component to the originating requirement. This systems architecture for operational Distributed Lethality builds the foundation for future Distributed Lethality research and will power operational simulations and wargames.				
14. SUBJECT TERMS Distributed Lethality, systems architecture, model based systems engineering, Surface Warfare			15. NUMBER OF PAGES 87	
			16. PRICE CODE	
17. SECURITY CLASSIFICATION OF REPORT Unclassified	18. SECURITY CLASSIFICATION OF THIS PAGE Unclassified	19. SECURITY CLASSIFICATION OF ABSTRACT Unclassified	20. LIMITATION OF ABSTRACT UU	

THIS PAGE INTENTIONALLY LEFT BLANK

~~Approved for public release, distribution is unlimited~~
Distribution authorized to Department of Defense and U.S. DoD Contractors only;
Administrative or Operational Use; December 2016. Other requests for this
document must be referred to President, Code 261, Naval Postgraduate School,
Monterey, CA 93943-5000 via the Defense Technical Information Center, 8725 John
J. Kingman Rd., STE 0944, Ft. Belvoir, VA 22060- 6218.

**A SYSTEMS ARCHITECTURE FOR OPERATIONAL DISTRIBUTED
LETHALITY**

Clay I. Johnson
Lieutenant Commander, United States Navy
B.S., United States Naval Academy, 2003

Submitted in partial fulfillment of the
requirements for the degree of

MASTER OF SCIENCE IN SYSTEMS ENGINEERING

from the

**NAVAL POSTGRADUATE SCHOOL
June 2016**

Approved by: Eugene Paulo
Thesis Advisor

Paul Beery
Second Reader

Ronald Giachetti
Chair, Department of Systems Engineering

THIS PAGE INTENTIONALLY LEFT BLANK

ABSTRACT

Distributed Lethality is a new concept in Surface Warfare that involves using small groups of surface combatants to go on the offensive against the enemy. This new concept requires structure and definition, and building a systems architecture for it is an effective way to provide both. This thesis investigates and defines the core requirements of Distributed Lethality and the capabilities that are necessary to meet these requirements. It builds an example mission flow for a Distributed Lethality scenario, and then defines the functions necessary to implement this flow. Finally, the model includes the components that perform the identified functions. The systems architecture for operational Distributed Lethality clearly demonstrates the connections and relationships between each element of the model, allowing for clear traceability from the smallest component to the originating requirement. This systems architecture for operational Distributed Lethality builds the foundation for future Distributed Lethality research and will power operational simulations and wargames.

THIS PAGE INTENTIONALLY LEFT BLANK

TABLE OF CONTENTS

I.	INTRODUCTION.....	1
A.	BACKGROUND	1
B.	SCOPE AND METHODOLOGY	2
C.	PURPOSE OF RESEARCH	3
D.	RESEARCH QUESTIONS.....	4
II.	RESEARCH METHODOLOGY	5
A.	CLASSICAL SYSTEMS ARCHITECTURE	5
B.	BUILDING THE ARCHITECTURE OF DISTRIBUTED LETHALITY.....	6
1.	Literature Review	6
2.	Identifying Current and Future Systems.....	6
C.	MODEL DEVELOPMENT	7
1.	DOD Architecture Framework.....	7
2.	Model Based Systems Engineering in Vitech’s CORE	9
3.	Systems Architecting Approach for Distributed Lethality	11
III.	OPERATIONAL SYSTEMS ARCHITECTURE	15
A.	DEFINITION	15
B.	REQUIREMENTS.....	15
1.	Offensive in Nature	17
2.	Provide Viable Targeting Data	17
3.	Rapidly Re-Task Adaptive Force Packages	18
4.	Limited Self Sustainment	19
5.	Use Current or Near-Future Resources.....	20
6.	Deceptive.....	20
7.	Dispersed.....	20
8.	Force the Adversary to React	21
9.	Operate with Limited Carrier Strike Group Support.....	21
10.	Localized Sea Control.....	22
11.	Integrate with the Marine Corps.....	22
C.	CAPABILITIES.....	22
1.	Tracing Capabilities to Requirements	23
2.	CA.2.1 Force Projection	26
3.	CA.2.2 Independent Command and Control	29
4.	CA.2.3 Temporary Sea Control.....	30
D.	OPERATIONAL ACTIVITIES	31

IV.	SYSTEMS ARCHITECTURE OF THE ANTI-SURFACE WARFARE CAPABILITY	35
A.	ANTI-SURFACE WARFARE ARCHITECTURE	35
B.	EXECUTION OF ASUW OPERATIONAL ACTIVITY	35
	1. OA.2.1 Determine Mission	36
	2. OA.2.2 Assemble Forces	38
	3. OA.2.3 Transit to AOR.....	39
	4. OA.2.4 Conduct ASUW	40
	5. OA.2.6 Refit/Re-arm	44
C.	FUNCTIONS OF ASUW	45
	1. Function.2.1 Deception	47
	2. Function.2.2 Communications	47
	3. Function.2.3 Search	47
	4. Function.2.4 Fix.....	48
	5. Function.2.5 Engage.....	48
D.	COMPONENTS OF ASUW	49
	1. Components Performing Function.2.3.1 Airborne Search	49
	2. Components Performing Function.2.3.2 Active Search	50
	3. Components Performing Function.2.3.3 Passive Search.....	51
	4. Components Performing Fuction.2.5.1 Airborne Engagement	52
	5. Components Performing Function.2.5.2.1 OTH Missile Engagement	53
	6. Components Performing Function.2.5.2.2 Horizon Missile Engagement	54
	7. Components Performing Function2.5.3 Naval Gunfire Engagement	55
V.	CONCLUSION	57
A.	KEY POINTS	57
B.	AREAS TO CONDUCT FURTHER RESEARCH	60
	1. Model Expansion.....	60
	2. Support to Simulations	60
	LIST OF REFERENCES	63
	INITIAL DISTRIBUTION LIST	67

LIST OF FIGURES

Figure 1.	Operational Architecture Approach. Adapted from Anderson (2010).	3
Figure 2.	VLS RAS OV-1. Source: Hess (2015).	7
Figure 3.	DODAF Viewpoints. Source: DOD (2015).	8
Figure 4.	CORE DODAF 2.02 Schema. Source: Vitech (2013).	10
Figure 5.	Systems Architecting Approach for Distributed Lethality. Adapted from Giachetti (2015).	12
Figure 6.	Distributed Lethality’s Requirements.	16
Figure 7.	USS <i>Stout</i> (DDG 55) Resupplying. Source: Navy (2011).	19
Figure 8.	Hierarchy of Distributed Lethality Capabilities.	24
Figure 9.	A Three Ship Amphibious Readiness Group. Source: Naval Today Staff (2011).	27
Figure 10.	Zumwalt’s 155 mm Advanced Gun System. Source: Business Wire (2012).	28
Figure 11.	Top level FFBD for OA.1 Perform Amphibious Operations Support.	33
Figure 12.	Detailed FFBD for OA.1.4 Conduct Amphibious Operations.	34
Figure 13.	Top Level FFBD for OA.2 Perform ASUW Mission.	36
Figure 14.	FFBD for OA.2.1 Determine Mission.	37
Figure 15.	FFBD for OA.2.2 Assemble Forces.	38
Figure 16.	FFBD for OA.2.3 Transit to AOR.	40
Figure 17.	FFBD for OA.2.4 Conduct ASUW.	41
Figure 18.	FFBD for OA.2.6 Refit/Re-arm.	44
Figure 19.	ASUW Functional Hierarchy.	46
Figure 20.	Components that Perform Function.2.3.1 Airborne Search.	50
Figure 21.	Components that Perform Function.2.3.2 Active Search.	51
Figure 22.	Components that Perform Function.2.3.3 Passive Search.	52
Figure 23.	Components that Perform Function.2.5.1 Airborne Engagement.	53
Figure 24.	Components that Perform Function.2.5.2.1 OTH Missile Engagement.	54
Figure 25.	Components that Perform Function.2.5.2.2 Horizon Missile Engagement.	55

Figure 26.	Components that Perform Function.2.5.3 Naval Gunfire Engagement.....	56
Figure 27.	Mapping Component Anti-Ship Tomahawk through the Model to Requirements.	59

LIST OF TABLES

Table 1. Mapping Capabilities to Requirements.....25
Table 2. Mapping Capabilities to Operational Activities32
Table 3. Mapping Operational Activities to Functions.....47

THIS PAGE INTENTIONALLY LEFT BLANK

LIST OF ACRONYMS AND ABBREVIATIONS

A2/AD	anti-access/area denial
AFP	adaptive force package
AMDR	air and missile defense radar
AO	area of operations
ARG	amphibious readiness group
ASCM	anti-ship cruise missile
ASUW	anti-surface warfare
ASW	anti-submarine warfare
BDA	battle damage assessment
BMD	ballistic missile defense
CONOP	concept of operations
CONREP	connected replenishment
DDG	Guided Missile Destroyer
DL	Distributed Lethality
DODAF	Department of Defense Architecture Framework
EMCON	emissions control
FFBD	functional flow block diagram
FLIR	forward-looking infrared
HEL	high energy lasers
HVU	high value unit
IAMD	integrated air and missile defense
IFF	identification friend or foe
ISIC	immediate superior in charge
LCS	Littoral Combat Ship
LRASM	Long Range Anti-Ship Missile
LPD	Landing Platform, Dock
LSD	Landing Ship, Dock
MBSE	model based systems engineering
MEU	Marine expeditionary unit
MIO	maritime interdiction operations

NSFS	naval surface fire support
ONR	Office of Naval Research
RAS	rearming at-sea
RAS	replenishment at-sea
SAG	surface action group
SURTASS	Surveillance Towed Array Sensor System
SWO	surface warfare officer
TLAM	Tomahawk Land Attack Missile
VLS	Vertical Launching System

EXECUTIVE SUMMARY

War at sea in the 21st century will be a lightning fast and deadly enterprise. Potential adversaries to the United States (U.S.) will seek to deny the U.S. Navy the ability to operate freely by using high-speed, long-range, and highly accurate weapons. This denial of access will significantly impact the Navy's traditional carrier strike group operations paradigm because the limited number of high-value assets are becoming increasingly vulnerable to these emerging threats.

To answer this danger to the Navy's dominance at sea, the surface Navy is rapidly developing and fielding a new concept called Distributed Lethality. The goal of Distributed Lethality appears straightforward: take the fight to the enemy with small groups of powerful surface combatants. The implementation of the Distributed Lethality concept, though, is much more complicated. As a new idea, Distributed Lethality presents a unique opportunity for the application of systems architecture concepts with the goal of better understanding what it will take to make Distributed Lethality work.

Systems architecting is the science and art of building and connecting all of the different ideas and components that are necessary for a system to operate. The output of this architecting is a model capable of better explaining the elements and interactions of the parts of the system. As a form of model-based systems engineering (MBSE), the model developed by the architecting process can act as a foundation for more detailed simulation work.

The process for developing the systems architecture for the operational section of Distributed Lethality is based on general system architecting concepts, the Department of Defense Architecture Framework (DODAF), and the Vitech Corporation's CORE schema. The process is dependent upon each element in the architecture being easily traceable to every other part of the model. The first step is to develop requirements that are linked to capabilities. Capabilities are the basis of operational activities that are implemented by functions. Finally, functions are allocated to the components that

perform them. This process was described by Dr. Ronald Giachetti during a systems architecting lecture at the Naval Postgraduate School on April 26, 1015.

This thesis builds the systems architecture for operational Distributed Lethality. It identifies and explores all of the requirements and capabilities of Distributed Lethality. There are 11 of these requirements, including localized sea control, offensive in nature, and rapid adaptive force package turnaround. These requirements then implement the various capabilities of Distributed Lethality, including amphibious operations support, anti-surface warfare, and strike operations.

From there, this thesis builds the entire model for one of the eight sub-capabilities, anti-surface warfare. This detailed model includes the mission flow of the capability, the functions required to execute the mission flow, and the components that execute the functions. The end result is a clear path between the physical systems through the model all the way to the requirements for which the physical systems are necessary.

This thesis establishes a baseline model for the entire system of operational Distributed Lethality. This model is the foundation for continued expansion and can be used to build detailed simulations, acting as a powerful tool for surface navy leadership as they continue to refine their ideas about Distributed Lethality.

ACKNOWLEDGMENTS

I would like to thank Professor Paulo and Paul Beery for all of their support through this process.

THIS PAGE INTENTIONALLY LEFT BLANK

I. INTRODUCTION

A. BACKGROUND

In January 2015, the Surface Warfare leadership of the Navy, including Surface Forces Commander Vice Admiral Thomas Rowden, Surface Forces Atlantic Commander Rear Admiral Peter Gumataotao, and the Director of Surface Warfare Rear Admiral Peter Fanta, released a new strategy for surface warfare that they called “Distributed Lethality” (Rowden, Gumataotao, and Fanta 2015). Their idea proposed a fundamental shift from defensive to offensive operations for the Navy’s surface combatants.

Their reasoning was simple: force a potential adversary to counter the U.S. Navy’s attacks and therefore limit the adversary’s ability to conduct its own attacks. Instead of the Navy’s surface forces constantly responding to the adversary’s attacks and playing defense, the admirals proposed that the tables be turned and that the Navy force the adversary to defend itself. Additionally, recent developments in technology and tactics that could limit the U.S. Navy’s ability to operate freely when and where it chooses dictate a change to the defense-first paradigm. As potential adversaries further develop Anti-Access/Area Denial (A2/AD) capabilities, the Navy’s ability to operate high value units (HVU) such as aircraft carriers and large-deck amphibious ships and to conduct unopposed strike operations is becoming more limited. The Navy’s traditional operational style of massed carrier strikes and cruise missile attacks are much less viable when the enemy has the capability to target and kill these assets at ranges that exceed those of the Navy’s aircraft and cruise missiles. If a carrier cannot be put at risk to conduct a strike, then Distributed Lethality becomes necessary to affect the enemy. Many small surface forces would be difficult to target and force the enemy either to react to the threat and therefore open the door to a carrier attack or to ignore the new threat and therefore to take losses.

In the ideas put forth by the Admirals Rowden, Gumataotao, and Fanta, small groups of surface combatants would be dispatched into a disputed operations area to establish temporary sea control. These small groups of surface combatants, traditionally

referred to as Surface Action Groups (SAG), are now called Adaptive Force Packages (AFP) and are referred to as such for this project. In this case, sea control refers to destroying or neutralizing all enemy forces capable of opposing the AFP. After temporary sea control has been established, the AFP will conduct its assigned mission, which could range from a land strike to an amphibious assault.

B. SCOPE AND METHODOLOGY

The overall vision of this project is to flesh out the relatively new idea of Distributed Lethality and to provide a definitive structure upon which planners can build future work and simulation. As an idea proposed by warfighters, the concept was a perfect candidate for a model based systems engineering (MBSE) analysis. To this end, the author has developed an operational architecture for Distributed Lethality that will enable the warfighters to understand better and to envision what they have proposed.

This project focuses on the operational side of Distributed Lethality, and specifically, building an architecture to aid in determining the operational effectiveness of the concept. This involves the determination of viable mission sets, which may exclude some missions that the author has deemed beyond the scope of Distributed Lethality. This project does not address how Distributed Lethality will fit in with current fleet tactics, which are centered around aircraft carrier operations. The operational Distributed Lethality architecture will, however, lend itself to the warfighters better understanding the strengths and weaknesses of Distributed Lethality, and therefore enable them to integrate Distributed Lethality more effectively into the fleet's overall strategy.

The operational architecture of Distributed Lethality is built to insure that all aspects of the architecture are traceable to the other portions. This is accomplished by first determining the definition and requirements of Distributed Lethality. From there, the capabilities necessary to accomplish these requirements are determined. These capabilities can be further deconstructed into functions, and then the functions could be deconstructed into the components that would execute the functions (see Figure 1).

As the systems architecture for Distributed Lethality grows larger as each element is decomposed, this thesis will only decompose one of the many capabilities or mission

areas into functions and components. The top levels of requirements and capabilities can then be used as building blocks for the development and decomposition of the remaining capabilities.

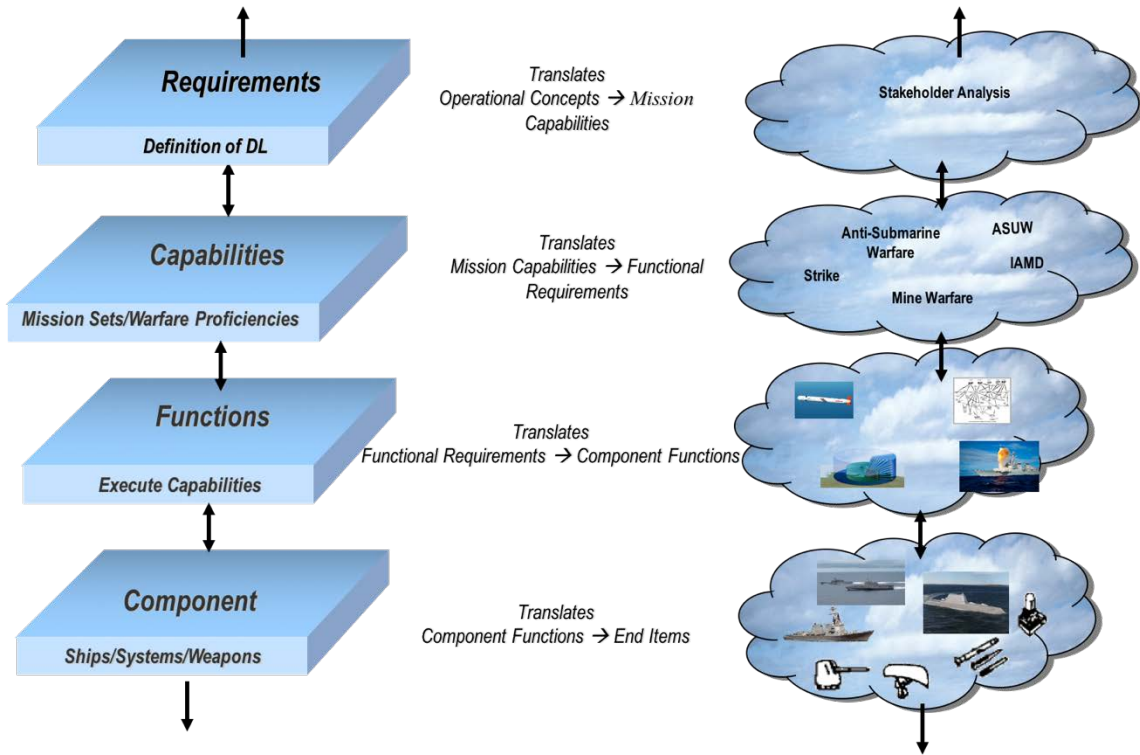

Figure 1. Operational Architecture Approach. Adapted from Anderson (2010).

C. PURPOSE OF RESEARCH

Surface warfare leadership, notably Fanta, Rowden, and Gumataotao (2015), have grown increasingly interested in fleshing out their idea. Commander, Surface Forces VADM Rowden has initiated a Distributed Lethality Working Group composed of members of his staff, members of the Surface Warfare Directorate N96, and academics to begin defining the concept. To support this broader effort, the author is using a systems engineering approach to build a traceable model or architecture for Distributed Lethality. As the concept is still in its infancy, the author is building the systems architecture from the very beginning. The overall goal of this research is to help define the new concept of Distributed Lethality and build a model that could be used to power future simulations

involving Distributed Lethality. For the purpose of this research, the specific mission area of interest is Anti-Surface Warfare (ASUW), which is discussed in more detail in Chapter IV.

The benefits of this research will be:

- to develop the requirements, capabilities, functions, and operational activities necessary to successfully conduct a Distributed Lethality operation
- to describe the physical components necessary to execute a Distributed Lethality mission
- to provide a top level architecture that can be further developed as required
- to provide a Distributed Lethality Framework that can be used to power future simulations and wargames.

D. RESEARCH QUESTIONS

- What is the systems architecture of Distributed Lethality, including its requirements and capabilities?
- What is the mission flow of one of Distributed Lethality's potential scenarios, and how do operational activities execute this flow?
- What different physical components are capable of completing the functions?

II. RESEARCH METHODOLOGY

A. CLASSICAL SYSTEMS ARCHITECTURE

Systems architecting is a well-established science that can be used to effectively model and explain complex systems. The operational systems architecture for Distributed Lethality presented in this paper was developed using a structure similar to that defined by the Department of Defense Architecture Framework (DODAF).

The term “architecture” has long been used to describe the science and art of designing and building physical structures. In the past several decades, though, the principles of architecture have been applied more frequently to systems engineering as a way to facilitate successful integration of multiple engineering domains. To take this one step further, architecting can be applied to not only physical systems, but also to systems of ideas, strategies, and tactics.

The architecture of a system is best presented and expressed through the use of models (Maier and Rechtin 2009). These models should clearly express the different systems and subsystems that make up a system and how each of these systems and subsystems connect and interact with each other. A single system is likely composed of many different types of models. A basic hierarchical model will show how subsystems and components combine to build a system, while a process model shows how these subsystems and components work together to complete a process. These different types of models are commonly referred to as views. Other major architectural model views may show the behavior or function of a system, how data is transferred or stored in a system, and how the system is managed or controlled (Maier and Rechtin 2009).

It is important to note that a systems architecture model does not need to be capable of simulating how a system actually functions. The architecture models provide a foundation on which future simulation work will be built.

B. BUILDING THE ARCHITECTURE OF DISTRIBUTED LETHALITY

1. Literature Review

The author assembled and reviewed all current information available on the new concept of Distributed Lethality. Currently, this information is only available in the form of a series of articles written for professional journals and defense news websites. These articles include specific discussions on the goals of Distributed Lethality, the logistics necessary to support Distributed Lethality, wargaming, Littoral Combat Ship (LCS) integration into Distributed Lethality, and potential concepts of operation (CONOPs) for Distributed Lethality. The Navy has not released any specific guidance or codification of the Distributed Lethality concept, although the Surface Warfare Directorate at N96 is in the process of developing the first such document.

2. Identifying Current and Future Systems

An important part in developing the operational systems architecture of Distributed Lethality is determining what systems will be available to execute the concept. A distinction must be made between currently available systems and those that will or may be available in the future. In order to better understand what systems may be available in the future to help execute the Distributed Lethality concept, the author reviewed the development status of future weapon systems like the SM-6 surface-to-air missile and the Long Range Anti-Ship Missile (LRASM). These weapons could have a significant impact on the success or failure of Distributed Lethality, as they greatly increase the offensive capability of Navy surface combatants. Additionally, a new capability involving rearming the Vertical Launching System (VLS) was investigated to determine its potential effect on Distributed Lethality. This VLS Rearming At-Sea (RAS) is a project being developed by the Office of Naval Research (ONR), and it could significantly increase the capability of surface combatants to conduct Distributed Lethality missions by decreasing the ships' turn around between missions (see Figure 2). Specifically, the idea of rearming VLS ships at sea involves a floating platform loading an assortment of missiles and then rendezvousing with the VLS ships at sea. The floating platform would then take the VLS ships alongside and using various technologies keep

both itself and the receiving ship stable enough for the VLS missile canisters to be loaded. Developing technologies such as VLS RAS could play a major role in building the systems architecture of Distributed Lethality, and therefore must be considered and included.

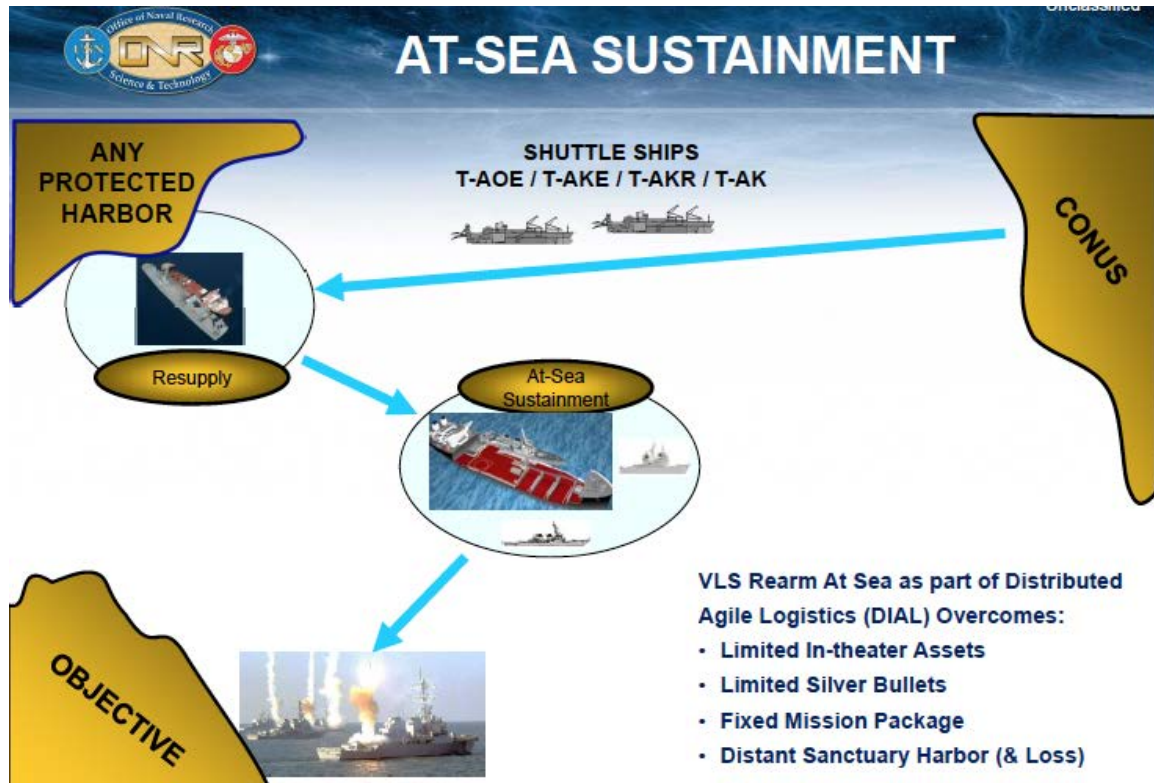

Figure 2. VLS RAS OV-1. Source: Hess (2015).

C. MODEL DEVELOPMENT

1. DOD Architecture Framework

The Department of Defense recognized the usefulness of systems architecting for managing programs and capabilities but decided that it needed a more specific design in order to make systems architecting ideas applicable to DOD subjects. To this end, the DOD incrementally developed its Architecture Framework, or DODAF. The most recent version of the DODAF was released in January of 2015 as v2.02 (Department of Defense 2015). The DODAF was designed to act as a decision making tool for managers. It did

this “by ensuring the sharing of consistent and common information across the Department, Joint Capability Areas (JCAs), missions, components, and programs” (Department of Defense 2015). While the DODAF is typically associated with the acquisition of new physical systems, it is flexible enough to be applied to a wide spectrum of subjects, including capabilities, tactics, and strategies, assuming that these are treated as systems or system of systems.

The DODAF is centered around different “viewpoints.” These viewpoints represent the different perspectives from which a system can be examined (see Figure 3). The DODAF defines eight different viewpoints, each useful in its own way. The viewpoints relevant to developing the systems architecture for Distributed Lethality are explained below.

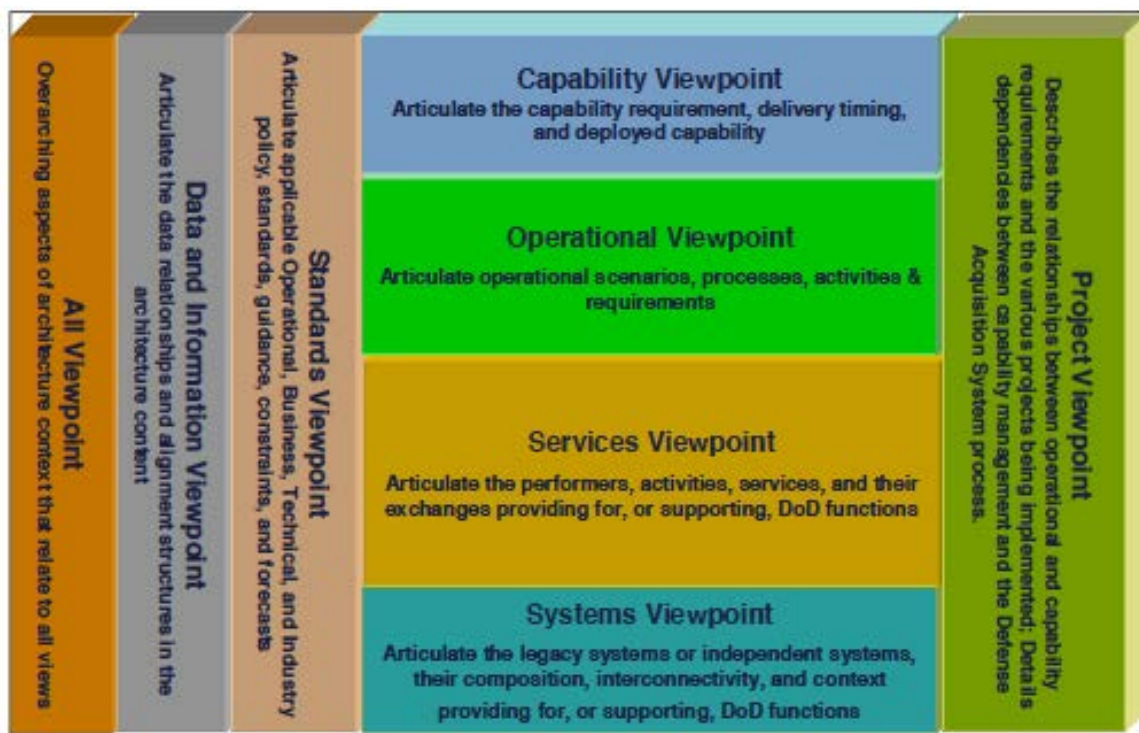

Figure 3. DODAF Viewpoints. Source: DOD (2015).

The capability viewpoint is an important starting point in developing the systems architecture of a system like Distributed Lethality. The models developed as part of the

capability model are integral in establishing traceability within the concept. Specifically, capability viewpoint 2, or CV-2, is a model that explains the capability hierarchies of the system. These hierarchies establish how each capability relates to the others, and therefore defines the relationships of the capabilities. A well-developed CV-2 is necessary in insuring that there is an actual need for each of the capabilities built into a system and shows how the capabilities support each other. This is accomplished by determining the desired endstate and working backward to determine the capabilities necessary to achieve that endstate.

Operational viewpoint 5b, or OV-5b, is another viewpoint that is applicable to Distributed Lethality. The OV-5b describes the operational activities associated with the system. These operational activities are defined as the actual missions that need to be accomplished in order to complete the capabilities described in the capability hierarchy. OV-5b models are essentially mission flow diagrams that explore how the determined capabilities are actually executed. OV-5bs include the actions that would be executed and the units or performers that would execute the actions. Inputs or stimuli and outputs could also be incorporated into the mission flow. These models assist greatly in determining how the system would actually accomplish the missions assigned to it.

2. Model Based Systems Engineering in Vitech's CORE

The Department of Defense Architectural Framework is very good at describing the overall requirements for its different viewpoints, but it does not explicitly show how each of the viewpoints could and should be built. The systems engineers at Vitech Corporation developed a software suite that was capable of doing just that. Vitech's CORE allows for a system to be modeled from top to bottom while meeting all of the requirements of DODAF's viewpoints. CORE does this through allowing the user to define all of the different "elements" of a system. CORE uses physical, functional, interface, and requirement elements as the building blocks of a model. From there, CORE allows the user to describe how each of the different elements are related to each other. It illustrates these connections through the CORE schema (see Figure 4). These

A functional flow block diagram describes how a process or situation would develop. The DODAF equivalent of a FFBD is an operational flow. FFBDs normally contain operational activity elements. These operational activities interact with operational item elements that come in the form of triggers, inputs, and outputs. CORE FFBDs can account for decisions, parallel activities, and loops in attempting to effectively model scenarios.

Relationship diagrams clearly display how elements of different types are related to one another. For example, once a system's capability elements have been fully decomposed, the lowest level capabilities can then be linked to corresponding operational activities. The CORE relationship between these two types of elements is "basis of." Therefore, a capability element can be the "basis of" an operational activity element. CORE can build diagrams to display the relationship between different types of elements. These diagrams are vital in allowing readers to "trace" ideas throughout the entire model. CORE is also capable of producing tables that express these relationships. This thesis uses a combination of diagrams and tables to show traceability between elements of different types.

3. Systems Architecting Approach for Distributed Lethality

The DODAF offers very well-defined guidance on how to develop the systems architecture of a new system. In this case, though, not all of the DODAF aspects described above are applicable to Distributed Lethality. Because of this, the author has used an amalgamation of general systems architecting concepts, the DODAF, and CORE functionalities in order to build the operational systems architecture of Distributed Lethality (see Figure 5). This method was discussed by Professor Ronald Giachetti at the Naval Postgraduate School on April 26, 2015 as using the central and most important elements of the CORE schema to build an architecture. This approach allows the most flexibility in accurately portraying the system without be bound to a specific format. The general approach to building this operational architecture ensures tracability within the model. It also ensures the most usable set of products to be the basis of future work.

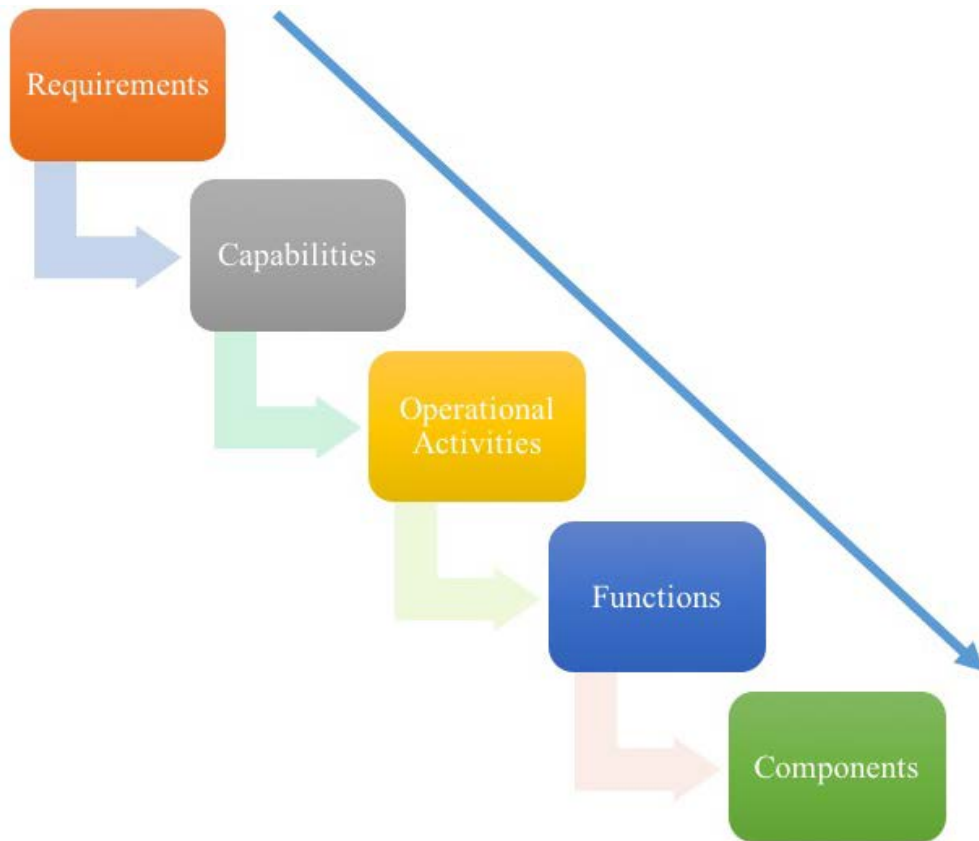

Figure 5. Systems Architecting Approach for Distributed Lethality.
Adapted from Giachetti (2015).

The process starts with determining the requirements of Distributed Lethality. These requirements are then entered as requirement elements in CORE. At the same time, the top level Distributed Lethality capability element is decomposed into its many sub-capabilities. Each capability can then be “implimented by” one or more requirements. If a capability cannot be “implimented by” one of the requirements, then it is most likely not necessary or should at least be evaluated further. This is a good example of how CORE allows for traceability and facilitates including only necessary elements in the architecture.

Once the capability elements have been decomposed as far as possible, the lowest level capabilities become the “basis of” operational activities. Each of the lowest level capabilities corresponds to one operational activity. These operational activities are then decomposed into sub-operational activities that form FFBDs to describe a series of

events. Operational items become “triggers” that initiate operational activities, and other operational items become “inputs” and “outputs” of certain operational activities.

The operational activities must be “implemented by” function elements that can also be decomposed into a hierarchy. Finally, some physical component element must perform each of the functions. Ultimately, the relationships like “performs,” “implemented by,” “basis of,” and “decomposed by” allow for the user to work through the entire system from the top requirement to the smallest physical component or vice versa.

This traceability will ideally allow for future model users to experiment with different physical components, which for Distributed Lethality are ships, aircraft, weapons, sensors, and other systems, and by working through the model, see the effects of changing these components on the operational flows, capabilities, and requirements. It is entirely possible that changing out a single physical component could result in one or more DL requirements not being met. The ability to discover this information through the model will be valuable for decision makers and planners as they determine how to best structure, deploy, and manage Adaptive Force Packages in order to meet mission requirements.

THIS PAGE INTENTIONALLY LEFT BLANK.

III. OPERATIONAL SYSTEMS ARCHITECTURE

A. DEFINITION

In order to develop the systems engineering architecture of Distributed Lethality the concept must be clearly defined. At this point no such definition exists. The only resources available on the subject are articles from professional journals. The Surface Warfare Directorate N96 and the Distributed Lethality Task Force are working to develop a concrete concept of operations for Distributed Lethality, which will presumably include a singular definition of the idea. One of the challenges of this project was to decide upon a definition of Distributed Lethality before the surface navy has codified it. To that end, the author has developed his own definition in order to develop a systems architecture. This definition is an amalgamation of ideas presented in articles, stakeholder meetings, and the author's personal experience as a Surface Warfare Officer (SWO).

Distributed Lethality is the doctrine of deploying multiple small groups of surface combatants across an area of operations in order to conduct a variety of actions against the enemy or take control of the sea in order to facilitate follow-on operations. Adaptive Force Packages dispatched to conduct Distributed Lethality missions will be composed of the best combination of available surface, Marine Corps, and aviation assets available in order to complete the designated mission.

B. REQUIREMENTS

The first step in building the architecture is to develop the requirements of the system. In this case, the author developed the requirements after conducting an in depth stakeholder analysis and using this analysis to determine a definition of Distributed Lethality. The requirements are also vital in determining what capabilities the system must have and therefore the system's ultimate physical composition. Determining the requirements of Distributed Lethality is not an easy task. Without specific literature from the Surface Warfare community, it has fallen upon the author to conduct a stakeholder analysis and investigate the available articles in order to determine what requirements are behind this new concept. The stakeholder analysis included meeting with members of the

Distributed Lethality Task Force and the sponsor of this project VADM Rowden and reviewing the personal operational experiences of the author. The information gathered during the literature review also contributed greatly to the development of the requirements for Distributed Lethality, although the author used his discretion in determining the most useful aspects of these analyses. After reviewing all of the available information, the author determined that SWO leadership envisioned that Distributed Lethality should meet 11 requirements (see Figure 6).

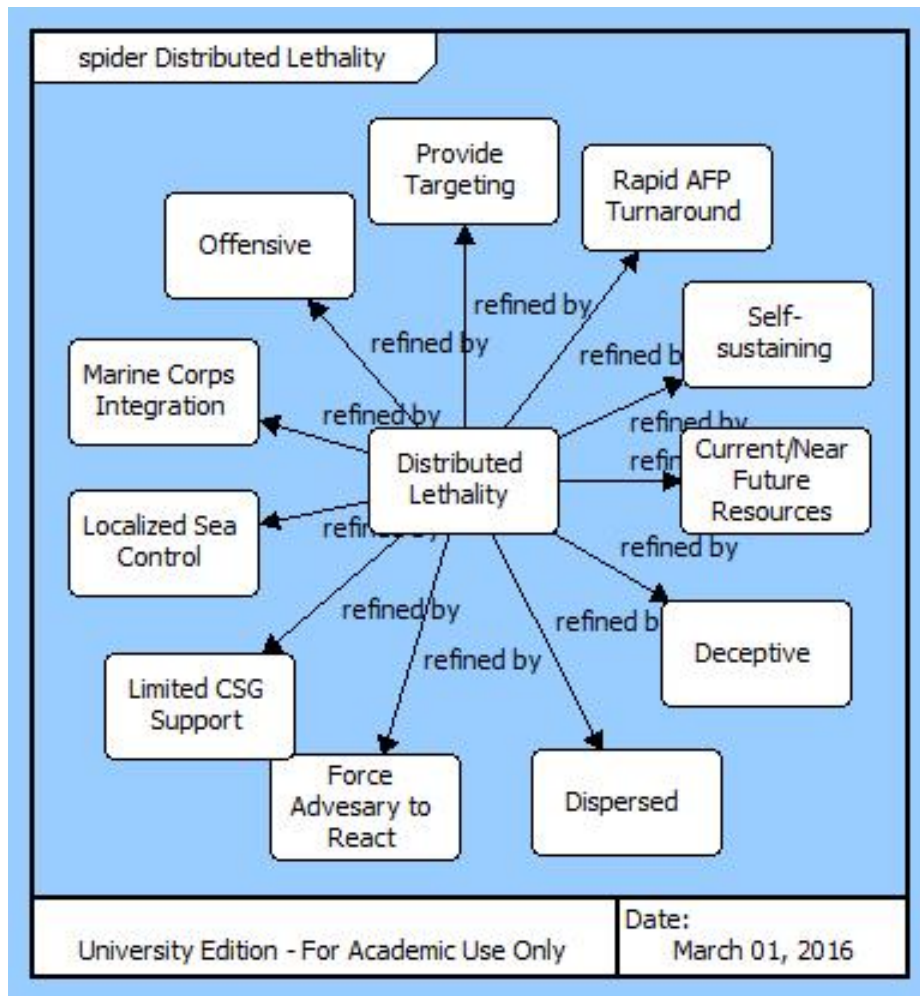

Figure 6. Distributed Lethality’s Requirements.

1. Offensive in Nature

Going on the offensive appears to be the single defining aspect of Distributed Lethality. The first sentence in the article introducing Distributed Lethality makes this abundantly clear, stating, “For more power in more places, the Navy should increase the offensive might of the surface force” (Fanta 2015). The admirals go on to explain how the surface navy will continue defending high-value units like aircraft carriers, DL required that surface ships take to the offensive to seize control of the seas from any potential adversary. The admirals also point out that going on the offensive would counter some of the enemy’s A2/AD capabilities by providing the enemy with a much more complex targeting picture. The surface navy has also stressed that a key tenet of DL is that every surface ship in the fleet should possess the sensors and weaponry necessary to threaten the adversary (Eckstein 2015).

Additionally, the Navy is already heavily investing in new or significantly improved offensive weapons. These weapons are being developed independently of DL work, but the capabilities that they will bring lend themselves to surface ships going on the offensive. These new weapons include the repurposed Tomahawk Land Attack Missile (TLAM), which in its Block IV variant has now been successfully tested against moving targets at sea (Carter 2015). This now gives much of the surface navy the capability of launching a subsonic anti-ship cruise missile at targets up to 1,000 nm away. The Navy is also testing the new SM-6, which is a supersonic missile that can be targeted against air and surface targets (McGrath 2016). These developments, along with the Harpoon replacement, will give the surface fleet significant offensive striking power.

2. Provide Viable Targeting Data

As small, nimble Adaptive Force Packages of surface ships deploy throughout a conflict area, it will be vital that they are capable of producing targeting data that can be used by other friendly assets to engage threats. This requirement is valid throughout the targeting spectrum. A deployed AFP could detect, track, and report on an enemy missile or aircraft strike headed toward a friendly asset. It could also report the position of enemy

surface ships so that an allied airstrike could be called in. This requirement to effectively target enemy assets is vital as AFPs disperse through an area of operations (AO).

3. Rapidly Re-Task Adaptive Force Packages

Most of the U.S. Navy's surface force is composed of multi-mission ships. All of the Navy's cruisers and destroyers are designed to be able to conduct simultaneous operations in different warfare areas. That is, these ships are capable of prosecuting a submarine, engaging enemy surface ships, launching land attack missiles, and defeating an incoming anti-ship cruise missile (ASCM) attack all at the same time. However, while each of the ships may be capable of this feat, they are also limited by the weapons that they are carrying at any given time. Navy destroyers and cruisers are limited to carrying only as many missiles as they have VLS cells, and this means that Navy leadership must at some point make decisions about what specific weapons go in those cells.

The ships that ultimately comprise any given Adaptive Force Package will undoubtedly be tasked with being prepared for multiple warfare areas. At the same time, though, the AFP form and deploy for a specific mission. An AFP tasked with neutralizing a forward enemy airfield in a strike mission will want for the majority of its VLS cells to be filled with Tomahawk Land Attack Missiles. Likewise, an AFP deployed to provide ballistic missile defense (BMD) to a friendly asset will need to be loaded with BMD capable Standard Missiles.

The nature of Distributed Lethality dictates that AFPs will not be deployed on a mission on a long-term basis. The ships will need to get in, complete their mission(s) and get out. A problem arises when an AFP has completed its assigned mission and is ready to be disbanded or given a new mission. For example, if the ships that make up an AFP were loaded for a BMD mission, they would not be equipped to conduct a strike mission. Therefore, AFPs must have the ability to rapidly change weapon loadouts and resupply so that they can be redeployed. Traditionally, this has meant pulling into a Navy base, as USS *Stout* did in the midst of supporting Operation Odyssey Dawn in 2011 (U.S. Navy 2011) (see Figure 7).



Loading supplies in Augusta Bay, Italy in March, 2011. *Stout* was in the midst of supporting Operation Odyssey Dawn against Libya.

Figure 7. USS *Stout* (DDG 55) Resupplying. Source: Navy (2011).

The ability to rapidly rearm ships of an AFP at sea plays a vital role in meeting this requirement. VLS Re-arm At Sea would allow ships to load weapons and shift weapon loadouts without the long transits that could be necessary in getting to a friendly and secure port.

4. Limited Self Sustainment

Because AFPs will be deployed in a dispersed manner, they may not have easy access to fleet oilers and supply ships. This supply would likely be concentrated around carrier or expeditionary strike groups in order to meet demands, while the ships of AFPs would deploy far forward. It may also be too risky to send an oiler to meet a deployed AFP, as it would be vulnerable to enemy attack and would therefore require some type of protection.

AFPs must be able to sustain themselves throughout the course of a mission. This would likely mean that ships would need to operate with far fewer fuel reserves than traditional Navy operations allow. AFPs would also need to deploy with as much ammunition as possible, as they would not have the ability to quickly rearm during a mission.

5. Use Current or Near-Future Resources

Military strategies are normally based on potential threats and capabilities that may not exist until many years in the future (LaGrone 2016). Distributed Lethality cannot afford this luxury of time. Distributed Lethality needs to be used as a strategy either now or in the very near future and is therefore dependent upon resources and capabilities that can be found in today's surface fleet. This means that only weapons and systems that the fleet is currently fielding or that are in development for deployment within the near future can be considered as valid contributors to the Distributed Lethality architecture. This allows for the inclusion of weapon systems that will be fielded in the next several years, such as high energy lasers (HEL) and railguns.

6. Deceptive

One of the main tenets of Distributed Lethality is "deceive-target-destroy" (Kline 2016). In modern war at sea, actively radiating sensors and communications can be suicide for a ship. At the same time, many weapon systems require that the shooter use an active sensor for targeting. This leads to ships attempting to stay passive until they have a good idea where the enemy is and then activating a sensor at the last minute to consummate the engagement. Kline proposes deceiving the enemy into using its active sensors through the tactical use of organic air assets (Kline 2016). This is but one example of what an Adaptive Force Package would need to do in order to deceive the enemy and thus gain the tactical advantage.

7. Dispersed

Dispersion of forces is a vital part of Distributed Lethality. Spreading offensive AFPs across a theater both disrupts the enemy's ability to target the ships and threatens the enemy from many axes (Kline 2016). As potential adversaries continue to develop more capable and lethal anti-ship weapons, dispersing multiple AFPs throughout an area of operations could seriously complicate the enemy's ability to find, fix, and target the ships, especially as they attempt to do the same with the "main" threat, the lurking carrier strike group(s).

In addition to complicating the targeting picture for the enemy, the wide dispersion of AFPs also means that the enemy would be threatened along many different fronts. This real threat could prevent the enemy from conducting planned offensive operations as it is forced to contend with defending itself.

8. Force the Adversary to React

Identified as the core objective of Distributed Lethality by the authors of the concept, forcing the enemy to adjust its defenses to defend against offensive thrusts is a key requirement for the concept (Rowden, Gumataotao, and Fanta 2015). By going on the offensive with multiple AFPs, the Navy will force the adversary to respond by defending all of the possible objectives that the AFPs could target. This allocation of defensive resources would play a major role in decreasing the enemy's offensive effectiveness, as it would be forced to defend itself at the expense of furthering its own objectives.

9. Operate with Limited Carrier Strike Group Support

When facing a near peer enemy within range of its land based weapons, a carrier strike group becomes extremely vulnerable (Filipoff 2016). The Navy has adopted the term Anti-Access/Area Denial to describe an adversary's ability to keep the U.S. Navy from controlling the seas in a certain area. This problem is one of the reasons why Distributed Lethality was developed. If the seas are too dangerous for carrier operations, the Navy must find some way to fight back and regain control of the seas.

For this reason, Adaptive Force Packages must be able to operate with little or no support from the carrier strike group and its assets. This includes advantages such as tactical air cover and airborne early warning systems, but also includes less tangible resources such as command and control and intelligence. The ships that make up an AFP must be prepared to operate without these resources or compensate for their absence with organic capabilities. Adaptive Force Packages may need to be augmented with detachments of different types in order to mitigate the loss of CSG resources.

10. Localized Sea Control

Since the end of the Cold War, the U.S. Navy has enjoyed almost complete control of the seas. That is, the Navy has been able to conduct operations such as strike or ballistic missile defense anywhere without being contested by a foreign power. In the near future the Navy will most likely not enjoy that luxury as potential adversaries continue to develop A2/AD capabilities. The authors of Distributed Lethality envision AFPs temporarily controlling small areas of the sea “for conducting follow-on power-projection operations” (Rowden, Gumataotao, and Fanta 2015).

11. Integrate with the Marine Corps

In their initial article on Distributed Lethality, the admirals stress the importance of integrating the Marine Corps into the concept (Rowden, Gumataotao, and Fanta 2015). Historically, the surface Navy has only considered combatants like cruisers, destroyers, and frigates as worthy of being detached from the strike group into a Surface Action Group. The inclusion of the Marine Corps and thus the amphibious ships that deliver them to the fight is the primary reason why the Distributed Lethality Task Force has taken to referring to Distributed Lethality assets as Adaptive Force Packages as opposed to Surface Action Groups. Including amphibious ships and the Marines that they carry in the Distributed Lethality concept adds a significant amount of capability to the spectrum of operations. Adaptive Force Packages must also be ready to work with the Army and Air Force, although to a lesser extent.

C. CAPABILITIES

Using the systems architecting approach outlined in Chapter II, with the requirements of Distributed Lethality determined the next step in building the systems architecture for the operational side of Distributed Lethality is to identify and model the capabilities of the concept. These capabilities can first be expressed as a hierarchy decomposed from the top level capability, “Distributed Lethality” (see Figure 8). This hierarchy is essentially the same as DODAF’s Capability Viewpoint 2. As the top level

capability, it has the designation CA.0 and decomposes into the children capabilities of CA.1 Logistics and CA.2 Offensive Operations. This project is only concerned with CA.2 and the offensive set of capabilities, so CA.1 Logistics is not further decomposed.

Offensive Operations can be decomposed into three sub-capabilities: CA.2.1 Force Projection, CA.2.2 Independent Command and Control, and CA.2.3 Temporary Sea Control. CORE uses the term “refined by” to further explain the decomposition of Offensive Operations into these three sub-capabilities. Each of these sub-capabilities can be further decomposed until their bottom-level capabilities are revealed. These bottom-level capabilities become the “basis of” CORE’s operational activities, which are mission flows. This progression means that the bottom-level capabilities are ultimately the warfare areas that the Distributed Lethality concept must be capable of executing.

It is very important to note that each capability must be linked directly to a requirement. In this way, additional capabilities not necessary to the system do not “creep” into the model, and therefore take resources from the necessary capabilities.

1. Tracing Capabilities to Requirements

Each of the capabilities developed from the model is “implemented by” one of Distributed Lethality’s requirements. This is the first step in validating the traceability of the model and ensures that all of the elements included in the model are ultimately necessary. In this case, the capabilities support one or more of the requirements (see Table 1). If a capability could not be shown to meet one of the identified requirements, then it was most likely unnecessary and therefore removed from the model. In this model the verification table confirms that all of the bottom-level capabilities are driven by one or more requirements, and all of the requirements are accounted for in at least one capability.

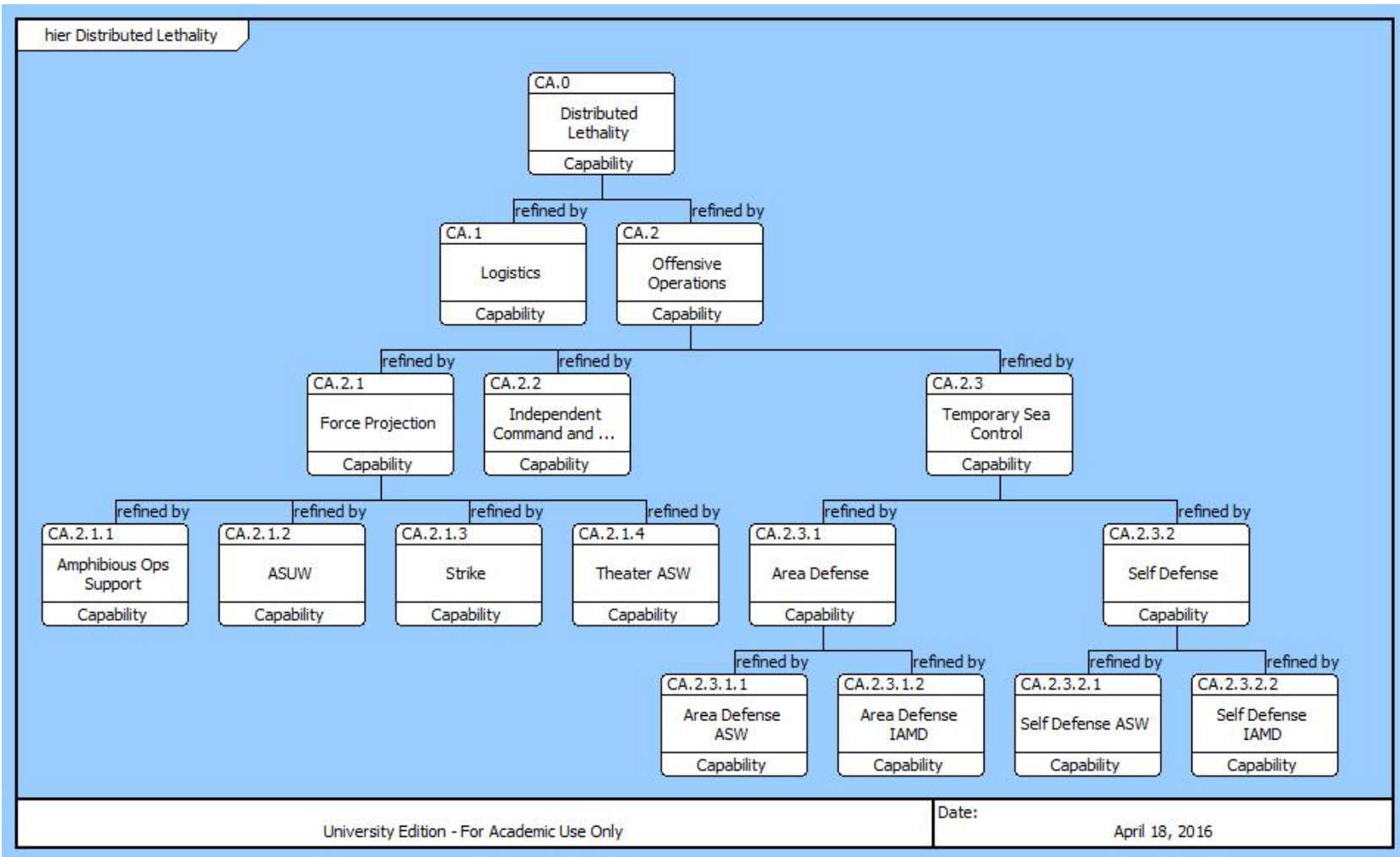

Figure 8. Hierarchy of Distributed Lethality Capabilities.

Table 1. Mapping Capabilities to Requirements.

<u>Number</u>	<u>Capability</u>	<u>Implemented By</u>
CA.2.1	Force Projection	Requirement Dispersed Requirement Force Advesary to React Requirement Localized Sea Control Requirement Offensive Requirement Rapid AFP Turnaround Requirement Self-sustaining
CA.2.1.1	Amphibious Ops Support	Requirement Current/Near Future Resources Requirement Deceptive Requirement Force Advesary to React Requirement Limited CSG Support Requirement Marine Corps Integration Requirement Self-sustaining
CA.2.1.2	ASUW	Requirement Current/Near Future Resources Requirement Offensive Requirement Provide Targeting
CA.2.1.3	Strike	Requirement Current/Near Future Resources Requirement Offensive Requirement Provide Targeting
CA.2.1.4	Theater ASW	Requirement Localized Sea Control Requirement Offensive Requirement Provide Targeting
CA.2.2	Independent Command and Control	Requirement Deceptive Requirement Dispersed Requirement Limited CSG Support Requirement Rapid AFP Turnaround Requirement Self-sustaining
CA.2.3	Temporary Sea Control	Requirement Dispersed Requirement Force Advesary to React Requirement Limited CSG Support Requirement Localized Sea Control Requirement Self-sustaining
CA.2.3.1.1	Area Defense ASW	Requirement Current/Near Future Resources Requirement Deceptive Requirement Localized Sea Control
CA.2.3.1.2	Area Defense IAMD	Requirement Current/Near Future Resources Requirement Localized Sea Control Requirement Provide Targeting
CA.2.3.2.1	Self Defense ASW	Requirement Current/Near Future Resources Requirement Deceptive Requirement Force Advesary to React Requirement Localized Sea Control Requirement Self-sustaining
CA.2.3.2.2	Self Defense IAMD	Requirement Deceptive Requirement Force Advesary to React Requirement Localized Sea Control Requirement Self-sustaining

2. CA.2.1 Force Projection

Projecting force has to be one of the three main sub-capabilities of Distributed Lethality's offensive operations capability. This capability concerns the deployment of an Adaptive Force Package with the goal of attacking the enemy and reducing its capability to execute its plan. The authors of Distributed Lethality say that one of the goals of the concept is to "seize the initiative," and projecting force is how this is accomplished (Rowden, Gumataotao, and Fanta 2015). From careful analysis of the goals and requirements of Distributed Lethality, this capability can be decomposed into at least four more sub-capabilities, which essentially become warfare areas. The sub-capabilities that refine Force Projection are CA.2.1.1 Amphibious Operations Support, CA.2.1.2 Anti-Surface Warfare (ASUW), CA.2.1.3 Strike Operations, and CA.2.1.4 Theater Anti-Submarine Warfare (Theater ASW). This capability can also be traced back to the requirements that it is implemented by (see Table 1).

a. CA.2.1.1 Amphibious Operations Support

The first of the four Force Projection sub-capabilities involves offensive amphibious operations. Integrating the Marine Corps into Distributed Lethality is one of core tenets that the authors propose for the concept (Rowden, Gumataotao, and Fanta 2015). This Marine Corps integration requires the use of the surface navy's amphibious ships, which have not traditionally been associated with the Surface Action Group concept. By changing the SAG into an Adaptive Force Package, the door is open to including amphibious ships. This may be a departure from the traditional deployment of an entire Marine Expeditionary Unit (MEU) with a Navy Amphibious Readiness Group (ARG), but dispersing one or two of the ARG ships with several destroyers or cruisers in an AFP could have a significant impact on enemy operations. First, a three-ship ARG, including a large deck helicopter carrier and two smaller amphibious ships, would make a tempting and vulnerable target for the enemy's A2/AD systems (see Figure 9). Additionally, deploying a Landing Ship, Dock (LSD) or a Landing Platform, Dock (LPD) with two destroyers in an AFP could threaten the enemy in a variety of ways. The embarked Marines could conduct small scale assaults and raids, and they could also

contribute to Maritime Interdiction Operations (MIO), disrupting the enemy's commerce activities. The destroyers of the AFP could contribute to the mission through Naval Surface Fire Support (NSFS), strike operations with land attack cruise missiles, and the defense of the force from surface, subsurface, and air attack. The Amphibious Operations Support capability can also be traced back to the requirements that it supports (see Table 1).



Figure 9. A Three Ship Amphibious Readiness Group.
Source: Naval Today Staff (2011).

b. CA.2.1.2 Anti-Surface Warfare

The second of the four capabilities derived from Force Projection is finding, fixing, and destroying enemy surface ships. This capability, referred to as Anti-Surface Warfare, was a core competency of surface warfare during the Cold War but deemphasized in the late 20th and early 21st centuries as the U.S. Navy began operating in the littorals more and more (Ho 2016). As the U.S. Navy now plans for the potential of facing a near peer on the seas, it must have surface forces capable of taking on enemy surface combatants without the benefit of carrier or land-based air forces. An AFP armed with large caliber guns, SM-6 missiles, and anti-ship Tomahawk cruise missiles could

present a powerful threat to enemy surface forces. The requirements that this capability support can be found in Table 1.

c. CA.2.1.3 Strike Operations

While the surface forces of the U.S. Navy may not have focused on ASUW since the end of the Cold War, they have become intimately familiar with strike operations. Every surface warship with the Vertical Launching System deploys with many Tomahawk land attack missiles in its magazine and is prepared to use them. In fact, as of March of 2011, the U.S. Navy had launched 2,000 Tomahawk missiles in combat (Reed 2011). This mission would continue to play a large role in Force Projection as part of the Distributed Lethality concept, as the missiles in a three ship AFP could have the capability of neutralizing a small airfield or base. Additionally, the Advanced Gun System of the new Zumwalt Class destroyers (see Figure 10) will enable the ship to strike targets at ranges up to 100 nautical miles with 155 millimeter warheads (Defense Industry Daily Staff 2014). The Strike Operations capability can be mapped to the requirements that it is implemented by as seen in Table 1.



Figure 10. Zumwalt's 155 mm Advanced Gun System.
Source: Business Wire (2012).

d. CA.2.1.4 Theater Anti-submarine Warfare

Theater Anti-submarine Warfare is offensive operations against sub-surface threats across a wide area. Traditionally, surface combatants have only been concerned with defensive, localized ASW, but the Force Projection capability of Distributed Lethality demands that these same surface ships go on the offensive against enemy submarines in order to disrupt the enemy's battle plan. Theater ASW has normally been dominated by long range patrol aircraft, underwater microphone arrays, and Surveillance Towed Array Sensor System (SURTASS) capable ships. Recent upgrades to the sonar suites of destroyers and cruisers, though, have greatly increased the ASW capabilities of these ships (Williams 2014). These upgrades could potentially give these surface forces the ability to influence and prosecute enemy submarines at great distances. The Theater ASW capability can be traced back to the requirements that it is implemented by (Table 1).

3. CA.2.2 Independent Command and Control

One of the three core sub-capabilities of Distributed Lethality, Independent Command and Control is a vital capability in the execution of any Distributed Lethality scenario. Ships of the U.S. Navy have operated under a relatively tight command and control structure, with almost constant access to their immediate superior in charge (ISIC), normally at the strike group level. Similarly, strike groups are in almost constant contact with the fleet that they are assigned to. These consistent communications enable operational commanders many opportunities to learn what subordinate units are doing and issue applicable orders.

In a Distributed Lethality scenario, though, this advantage could be lost as the adversary moves to restrict the U.S. Navy's access to the electromagnetic spectrum. Therefore, and Adaptive Force Package must be prepared to conduct its mission without constant guidance from the strike group or fleet commander. This problem then becomes one of technical capability and organizational structure. First, the ships of the AFP must be able to effectively communicate, presumably at relatively close distances as the AFP operates together. Second, the AFP must have a clear and concise command structure,

which could involve assigning a commodore with his or her associated staff or assigning AFP commander to the senior commanding officer of the group. Regardless, either organizational option must have the ability to make command decisions in the absence of guidance from the strike group or fleet commander.

4. CA.2.3 Temporary Sea Control

Controlling the seas in order to execute missions securely has been a core desired capability of every navy that has ever sailed. Since the end of the Cold War, the U.S. Navy has had almost complete control of the seas and therefore had the freedom to conduct naval operations from strike to maritime security without worrying about the threat posed by a rival navy. In the case of a naval war with a capable adversary, the control of the seas that the Navy has enjoyed would no longer be guaranteed. In fact, the adversary's A2/AD capabilities could result in a loss of sea control.

Distributed Lethality could offer an avenue to allow the Navy to control a small operational area for a limited amount of time (Rowden, Gumataotao, and Fanta 2015). While the AFP is controlling this localized area, the Navy, the other services, and allies would be able to execute their missions. The temporary sea control capability would represent a more defensive concept of operations than the offensive force projection capability, but would support the Distributed Lethality concept exceptionally well.

The Temporary Sea Control capability is further decomposed into two more sub-capabilities: area and self defense. The Area Defense sub-capability tasks the AFP with defending both other units within the AFP and other friendly assets as they conduct missions. The Self Defense sub-capability is the capability of each ship in the AFP to defend itself.

a. CA.2.3.1 Area Defense

As part of the Temporary Sea Control capability, Area Defense is the ability of the Adaptive Force Package to protect the sea and air space in a localized area for a finite amount of time. This means that the ships of the AFP must be able to extend their

defensive zones so that they include other friendly assets and other ships of the AFP that may not be as capable of defending themselves from certain threats.

The Area Defense capability is decomposed into two sub-capability threat areas. The AFP must be prepared to conduct anti-submarine operations in order to defend less-capable assets. For example, amphibious ships do not have any capability to fight a submerged threat, so at least one other ship in the AFP must be able to extend its CA.2.3.1.1 ASW capability to cover the amphibious ships. The same would apply to other friendly assets operating in the temporarily controlled area. The ships of the AFP must also be capable of area protection in the form of CA.2.3.1.2 Integrated Air and Missile Defense (IAMD). Once again, ships of the AFP must be capable of protecting friendly assets from attacks by aircraft and missiles. This could include an Aegis ship using its SPY radar and SM-2 missiles to help protect a less capable amphibious ship. Additionally, ships of an AFP could be tasked with ballistic missile defense operations. The AFP would be dispatched to take temporary control of an area conducive to protecting a land-based asset that was being threatened by ballistic missile attack. Once the AFP had established temporary sea control, it could use a BMD capable ship to search for and potentially engage any ballistic missiles launched at the defended asset. Each of these sub-capabilities can be traced back to the requirements as seen in Table 1.

b. CA.2.3.2 Self Defense

While self defense is a capability assumed by any naval commander, it is important that it is explicitly built into the capability architecture to ensure that all of the operational activities, functions, and components that result are fully accounted for in the model. Self Defense decomposes into CA.2.3.2.1 ASW and CA.2.3.2.2 IAMD, just as Area Defense did. Each ship assigned to an AFP must have the capability to defend itself against these two threats, either through hard killing the threat with a weapon or soft killing the threat through decoys and countermeasures.

D. OPERATIONAL ACTIVITIES

With the hierarchy of capabilities completely decomposed and traced back to the requirements, the operational activities that are based on the lowest level of capabilities

can be built. This is a continuation of the overall approach for developing the systems architecture that is outlined in Chapter II. Each of the bottom level capabilities has one corresponding operational activity. This linkage is the next step in ensuring traceability throughout the entirety of the model (see Table 2).

Table 2. Mapping Capabilities to Operational Activities

Number	Capability	Basis Of
CA.2.1.1	Amphibious Ops Support	OperationalActivity OA.1 Perform Amphibious Ops Support
CA.2.1.2	ASUW	OperationalActivity OA.2 Perform ASUW Mission
CA.2.1.3	Strike	OperationalActivity OA.3 Perform Strike Mission
CA.2.1.4	Theater ASW	OperationalActivity OA.4 Perform Theater ASW Mission
CA.2.3.1.1	Area Defense ASW	OperationalActivity OA.5 Perform Area Defense ASW Mission
CA.2.3.1.2	Area Defense IAMD	OperationalActivity OA.6 Perform Area Defense IAMD Mission
CA.2.3.2.1	Self Defense ASW	OperationalActivity OA.7 Perform Self Defense ASW Mission
CA.2.3.2.2	Self Defense IAMD	OperationalActivity OA.8 Perform Self Defense IAMD Mission

The operational activities decompose into mission flows and are represented by functional flow block diagrams that are the same as DODAF's Operational Viewpoint 5b. An example of this top level mission flow for OA.1 Perform Amphibious Operations Support is shown in Figure 11. Each of the operational activity elements within an FFBD can be further decomposed to add more details to the mission flow. The detailed FFBDs of operational activities can become extensive as they map out the Inputs, Outputs, and Triggers that dictate the flow of a mission. Figure 12 is a detailed FFBD expanding the mission flow for OA.1.4 Conduct amphibious operations. Because of the intricate detail required in order to fully explore one of the operational activities in Table 2, only one of these mission flows will be completely developed. Chapter IV fully builds the mission flow for OA.2 Perform Anti-Surface Warfare Mission and then derives the function elements that execute that mission and also the components necessary to carry out those functions.

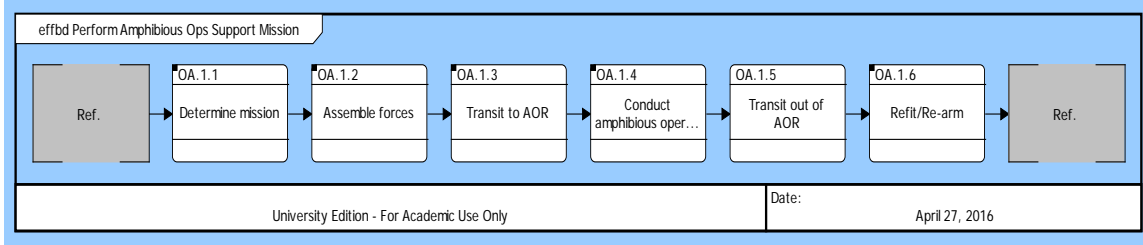

Figure 11. Top level FFBD for OA.1 Perform Amphibious Operations Support.

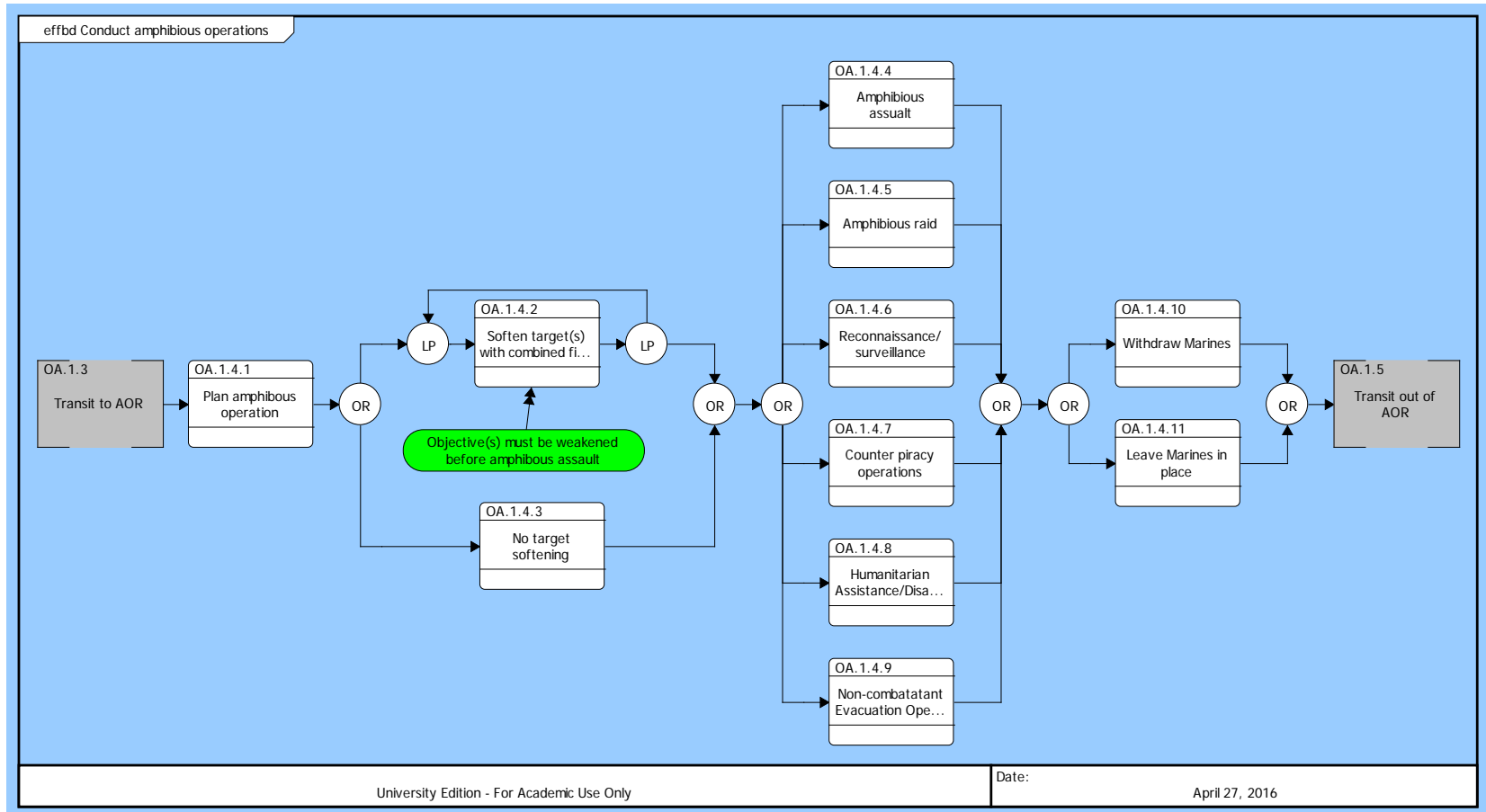

Figure 12. Detailed FFBD for OA.1.4 Conduct Amphibious Operations.

IV. SYSTEMS ARCHITECTURE OF THE ANTI-SURFACE WARFARE CAPABILITY

A. ANTI-SURFACE WARFARE ARCHITECTURE

The Anti-Surface Warfare capability and the ASUW operational activity that it is the basis of provide an opportunity to expand the operational architecture of Distributed Lethality to its conclusion. Because of the scale required to fully build each operational activity, this thesis only completely explores one of the eight vital sub-capabilities identified in Chapter III. After completely expanding ASUW's operational activities or mission flow, the functions required to execute these operational activities are developed. From these functions, the components necessary to complete the functions are finally derived. This part of the architecture makes it possible to easily see how physical systems and weapons can influence the Distributed Lethality concept's ability to accomplish the ASUW capability.

B. EXECUTION OF ASUW OPERATIONAL ACTIVITY

The first step in developing the operational architecture for the ASUW capability of Distributed Lethality is to fully expand operational activity OA.2 Perform ASUW Mission. Operational activities are decomposed into sequential mission flows instead of hierarchies. These mission flows make it possible to walk through the mission as if an ASUW scenario were playing out and explore all of the events that are likely to occur. The top level operational activity is the mission flow that encompasses the ASUW mission from start to end (see Figure 13). This top level may appear simplistic, but each of the operational activities that it contains is further decomposed into more detailed mission flows later in this chapter. It is important to note that additional numbers at the end of operational activity titles (normally "1") are only administrative necessities required by CORE and should be ignored by the reader.

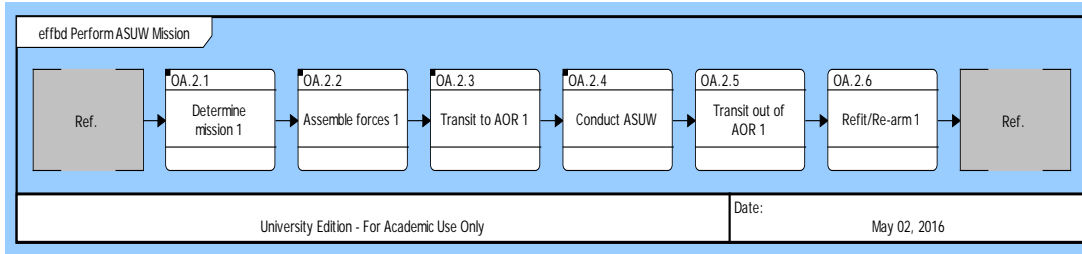

Figure 13. Top Level FFBD for OA.2 Perform ASUW Mission.

Working through the expanded operational activity is most easily accomplished using a simple scenario to illustrate how the mission would flow. For the purposes of this thesis the following scenario is used to assist in describing the architecture of the ASUW operational activity. The United States is currently engaged in the opening phases of a kinetic battle in the Western Pacific Ocean and South China Sea against a near-peer adversary, China. The enemy has successfully established an A2/AD zone out to the second island chain, and the U.S. has determined that China has the capability to successfully target and attack an aircraft carrier operating anywhere inside this zone. Chinese Navy surface ships have been freely conducting operations throughout the area, and the commander of the U.S. Navy’s Seventh Fleet has decided to dispatch an Adaptive Force package into the A2/AD zone in order to attack the Chinese Navy’s surface ships. The objective is both to destroy the enemy’s ships and to force the Chinese to allocate resources to defend from the threat posed by the AFP.

1. OA.2.1 Determine Mission

The first sub-operational activity in the ASUW mission flow OA.2.1 Determine mission is initiated as fleet leadership makes the determination to dispatch an AFP in order to conduct an attack against enemy warships. This operational activity decomposes into a more detailed flow (see Figure 14). The mission flow begins as the operational leaders determine what the specific objective of the AFP will be. From the scenario briefly described earlier in this chapter, the Seventh Fleet commander determined that the mission objectives of this AFP are to destroy Chinese surface ships and to force the Chinese to allocate resources to defending their navy from the threat the AFP poses.

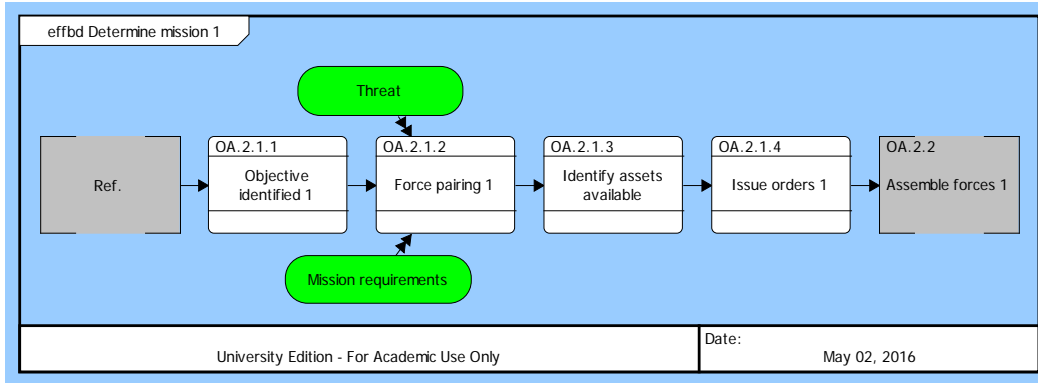

Figure 14. FFBD for OA.2.1 Determine Mission.

With the objective identified, the appropriate composition of the AFP must be decided upon. As seen in Figure 14, the Force pairing is dependent upon two triggers: Threat and Mission requirements. At this point, the staff develops a series of potential packages based on what is needed to accomplish the mission of destroying the enemy navy and what type of threats the AFP could encounter. For this scenario, the AFP needs to include assets capable of offensive surface warfare, which should include both long range targeting capabilities and long range surface to surface weapons. The AFP must be prepared to defend itself from air, surface, and subsurface attack, too. For this scenario, the Seventh Fleet staff determines that the AFP should be comprised of one Zumwalt Class DDG with an aviation detachment, a Flight IIA Arleigh Burke Class DDG with an aviation detachment, and a Harpoon-equipped Ticonderoga Class cruiser or Flight I Arleigh Burke Class DDG.

Once the Force pairing has been accomplished, the Seventh Fleet needs to Identify assets available that meet the force composition requirements set forth in the previous operational activity. It is possible that the staff could find that the assets available for tasking either do not meet the Force pairing requirements or are already involved in other tasking. In this case, the commander would have to make the decision to either deploy a less capable AFP, change the objective of the AFP, or not deploy the AFP at all. For the sake of continuing the development and explanation of the operational activity, though, the Seventh Fleet is able to identify a Zumwalt DDG, a Flight IIA DDG, and a Flight I DDG, therefore meeting the Force pairing requirements. The last step in the

Determine mission operational activity is for the commander to issue orders assigning units to the task force and designating a commander to lead it.

2. OA.2.2 Assemble Forces

As the flow of OA.2.1 Determine mission concludes, OA.2 Perform ASUW Mission moves into its next major phase, OA.2.2 Assemble forces (see Figure 13). This operational activity breaks down into a more detailed mission flow (see Figure 15). The first operational activity in this FFBD is OA.2.2.1 Establish commander. The determination of who is to command the AFP should have been made in OA.2.1.4 Issue orders, but it is during the Establish commander operational activity that the chosen commander consolidates his or her command. This is also the new commander's opportunity to establish his or her expectations of the assigned units and the operating procedures for the AFP, as the ships assigned to it may not have worked closely together previously.

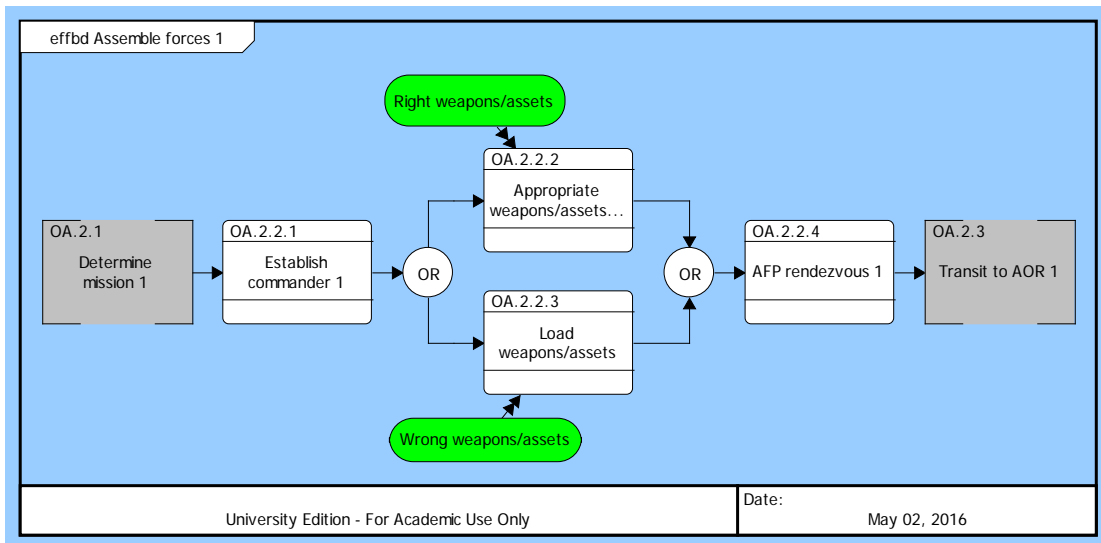

Figure 15. FFBD for OA.2.2 Assemble Forces.

After the commander has been established, the FFBD moves to the first decision junction, an “OR” block in CORE. In this case, the decision is dictated by whether or not the ships assigned to the AFP have the appropriate weapons and assets for the mission. If

the ships have the right weapons and assets, then this trigger, shown in green in the FFBD, moves the mission flow to OA.2.2.2 Appropriate weapons/assets. If the trigger is “Wrong weapons/assets,” then the mission flow goes to OA.2.2.3 Load weapons/assets. OA.2.2.3 Load weapons/assets is an example of an operational activity that could be decomposed much further, as the flow of loading weapons and assets could become very complex. It could involve VLS Rearm at Sea, pulling into port, or having to wait for an aviation detachment of helicopters to come into theater. Because of the detail required, this level of decomposition is outside of the scope of this thesis but could be built upon in the future to more accurately model the system.

After the ships in the AFP are correctly armed and have the appropriate assets on board, the ships need to rendezvous. The location of this rendezvous depends on the disposition of the ships. The commander could determine to rendezvous outside of the operational area and then proceed there as a composite unit, or he or she could decide to have each of the ships proceed to the operational area independently and rendezvous in the vicinity of the mission area.

For the scenario laid out earlier in the chapter, the flow of OA.2.2 Assemble forces may proceed like this: the Seventh Fleet determines that the Zumwalt’s commanding officer is the senior of the three captains, and he will command the AFP in addition to his ship. The Zumwalt’s commanding officer takes operational control of the other two DDGs assigned to the AFP and begins to establish reporting responsibilities. In this case, each of the three ships has a weapons loadout appropriate for ASUW, and the necessary aviation detachments are already embarked. The commander of the AFP orders the ships to rendezvous at a location outside of the A2/AD area so that they can proceed to their mission area as one unit.

3. OA.2.3 Transit to AOR

After the Adaptive Force Package has been assigned and assembled, it needs to deploy to the area of operations where it will be conducting its mission. The FFBD for OA.2.3 Transit to AOR is relatively simple compared to the first two phases of the ASUW operational activity (see Figure 16).

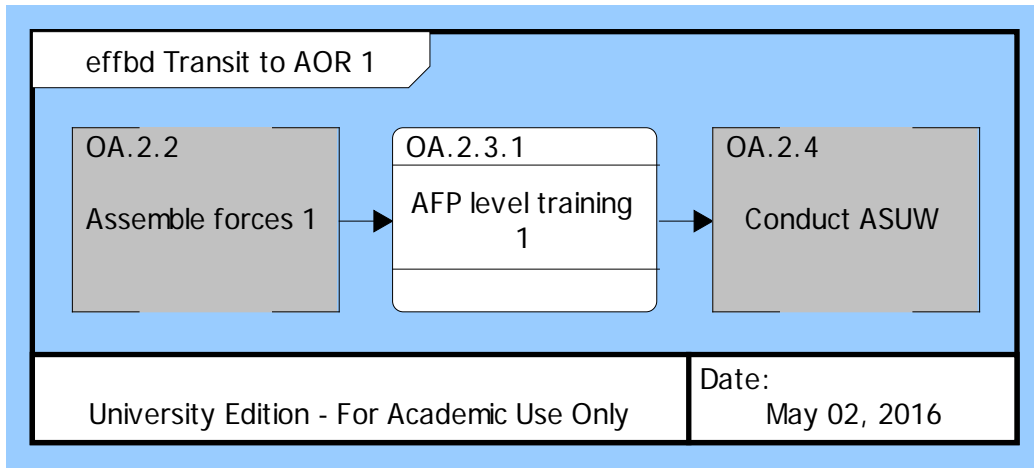

Figure 16. FFBD for OA.2.3 Transit to AOR.

During this part of the mission flow the AFP will train together to prepare for the mission. Due to the ad hoc nature of Distributed Lethality, it is possible that the ships assigned to the AFP have never worked closely together, so the commander would use the transit time to conduct as much training as possible while still proceeding to the mission area.

4. OA.2.4 Conduct ASUW

As the AFP arrives in the mission area it transitions to OA.2.4 Conduct ASUW. This operational activity requires the most detail and is by far the most intricate of the FFBDs described so far (see Figure 17). The first element encountered in this FFBD is an “AND” block, indicating that each of the branches stemming from it could be taking place at the same time. In the case of Conduct ASUW, the ships of the AFP would be conducting emissions control (EMCON) as necessary in order to protect themselves from detection and targeting. Additionally, if the AFP is attacked, represented by the green trigger Enemy attack operational item, then it would defend itself. Therefore, OA.2.4.1 EMCON and OA.2.4.16 Self-defense operational activity extend for the duration of OA.2.4 Conduct ASUW.

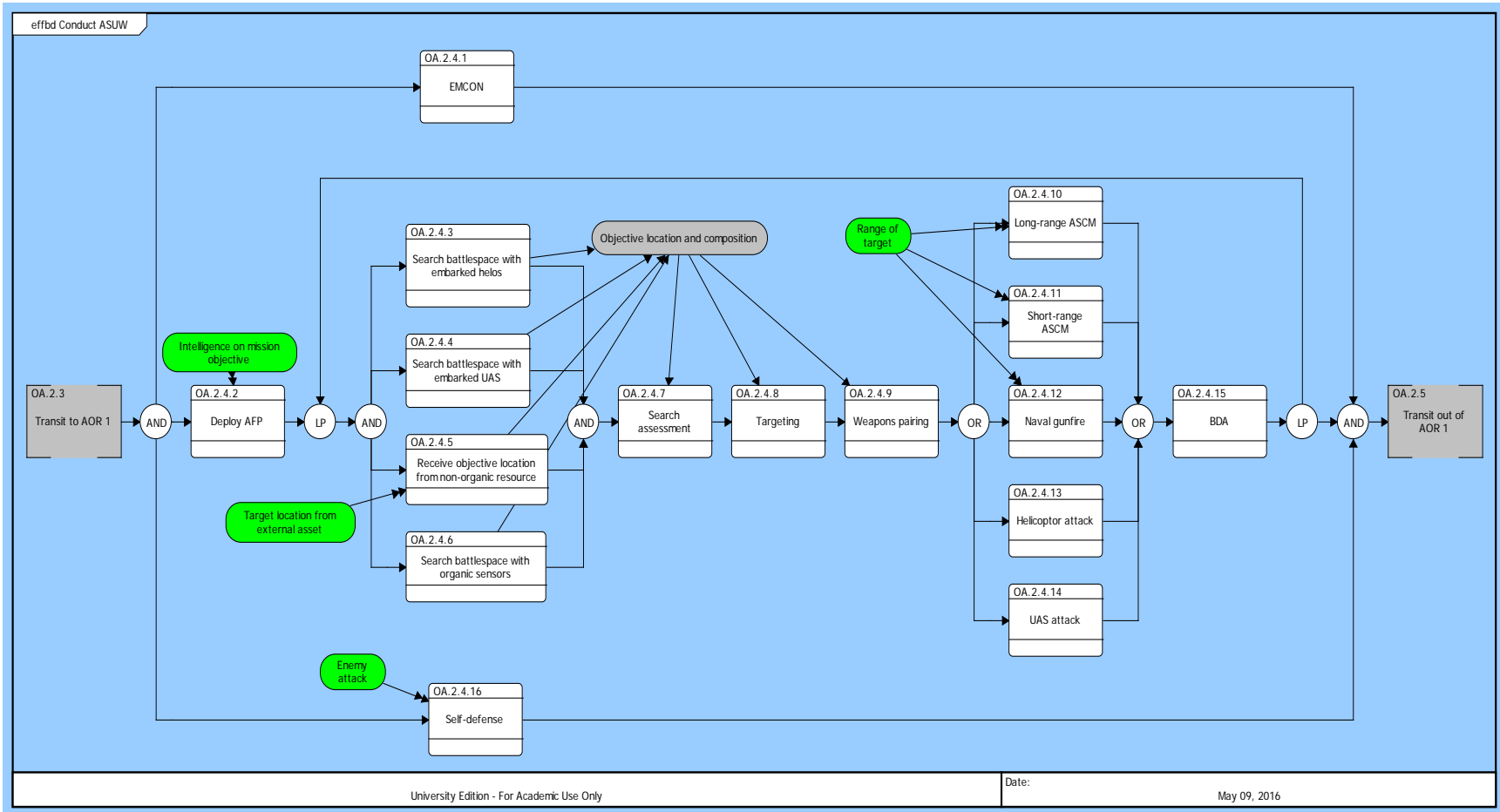

Figure 17. FFBD for OA.2.4 Conduct ASUW.

The main path through the Conduct ASW operational activity starts in OA.2.4.2 Deploy AFP. The trigger Intelligence on mission objective dictates how the commander deploys the AFP. The next set of elements involve searching for enemy naval vessels. This search could happen in four different ways that could all be taking place simultaneously and are therefore represented by branches from an “AND” block. The AFP could search the battlespace with embarked helicopters, unmanned aerial systems, or organic sensors such as radars or electronic surveillance. Additionally, the location of targets could be pushed to the AFP from an external asset, represented by a trigger in the FFBD. OA.2.4.3 through 2.4.6 represent these different search methods.

Each of the search operational activities produce the output operational item Objective location and composition, assuming that the search is successful. This output then becomes an input for the next several operational activities in the FFBD. In OA.2.4.7 the AFP evaluates the input Objective location and composition to determine whether or not the search revealed enough information to proceed to OA.2.4.8 Targeting. The Targeting operational activity once again takes the input Objective location and composition to develop a targeting solution for the enemy ships. This input is used again in OA.2.4.9 Weapons pairing as the AFP’s commander decides what system to use to engage the enemy warships.

After the commander has determined which of the AFP’s weapon systems are capable of engaging the enemy ships, the FFBD moves into a decision “OR” block. The AFP can use any one of or a combination of the five branches of this “OR” block to engage the enemy, assuming that the AFP is equipped with each of the weapons. OA.2.4.10 Long-range ASCM, OA.2.4.11 Short-range ASCM, and OA.2.4.12 Naval gunfire are each dependent upon the trigger Range of target. If the target is over the horizon, then a short-range ASCM and naval gunfire might not be able to engage it. At the same, the commander also has the options of OA.2.4.13 Helicopter attack and OA.2.4.14 UAS attack.

With the attack completed, the AFP then conducts a battle damage assessment (BDA) in order to determine if the attack was successful. OA.2.4.15 BDA then leads into a “LP” block, representing a loop. If the BDA reveals that some of the enemy warships

survived the attack, then the loop allows for the FFBD to cycle back to the beginning so that the entire process can play out again. If the BDA results in all enemy targets being destroyed or neutralized, then the FFBD for OA.2.4 Conduct ASUW concludes. At this point in the Perform ASUW Mission operational activity, the AFP has completed its assigned mission and the FFBD moves on to OA.2.5 Transit out of AOR.

The Chinese scenario illustrates how OA.2.4 Conduct ASUW would unfold in a real conflict. As the AFP enters the mission area inside the second island chain, the commander deploys the three-ship AFP in a manner that allows for the collective defense while extending sensor coverage as much as possible. At the same time, the AFP sets a restrictive emissions condition, limiting the use of active radars and radio communications. This restrictive EMCON makes searching the battlespace more difficult for the AFP but also makes it much more difficult for the Chinese to detect and localize the AFP.

The AFP then begins to search the battlespace. The ships with helicopter detachments launch the helicopters in a coordinated search effort while using electronic warfare suites to search the electromagnetic spectrum for emissions from Chinese warships. One of the ship's electronic warfare suites detects an air search radar associated with a Chinese destroyer, so a helicopter deploys down the radar's line of bearing. The helicopter finds a Chinese frigate and destroyer operating together approximately 60 nautical miles from the AFP. The AFP now holds the Chinese warships with two sensors and has enough information to target them.

The commander rules out a helicopter attack because of the anti-air warfare capabilities of the Chinese destroyer. Based on the ships' range from the AFP, the commander then decides to attack the Chinese with Harpoon ASCMs launched from the Flight I Arleigh Burke DDG. Immediately following the attack, a helicopter investigates the Chinese ships and performs a battle damage assessment. The Chinese frigate is dead in the water and burning in several places. The Chinese destroyer is still making way, but appears to have a list to port. The destroyer's superstructure is mangled and its air search radar is no longer radiating. The AFP commander decides to finish both ships and moves

the AFP into gun and short-range missile range. The AFP proceeds to sink both Chinese ships.

5. OA.2.6 Refit/Re-arm

With the mission complete, the AFP transits out of the AOR and begins planning for replenishment. OA.2.6 Refit/Re-arm allows two options for this. The ships could either conduct replenishment at sea or pull into a friendly port (see Figure 18). The “OR” block indicates the decision between these two routes. In OA.2.6.1 RAS/CONREP the ships of the AFP get fuel via replenishment at sea (RAS) and stores via connected replenishment (CONREP). The ships then move on to OA.2.6.2 VLS Re-arm At Sea using the technology the Office of Naval Research is developing. Loading VLS missiles as sea would prevent the ships from having to pull into a port, potentially saving a lot of time. If VLS Re-arm At Sea is not available, then OA.2.6.3 Pull into port for re-arm/refit is the other available option. The AFP pulls into the closest friendly port to take on fuel, stores, and ammunition. At this point, the ships and detachments of the AFP are ready and available for new tasking, which could involve keeping the AFP together for a similar or different mission or sending each ship on to a different assignment. OA.2.6.4 AFP assets available for new tasking is the last operational activity in OA.2 Perform ASUW Mission.

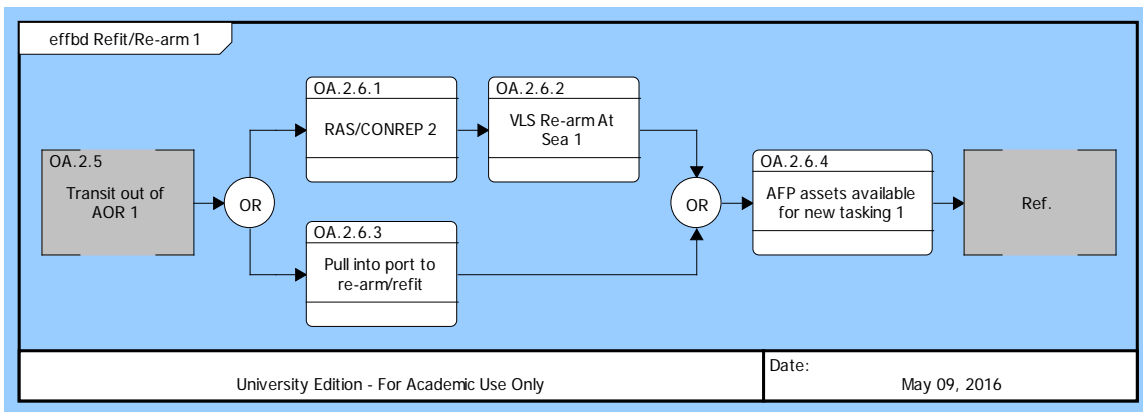

Figure 18. FFBD for OA.2.6 Refit/Re-arm.

C. FUNCTIONS OF ASUW

The next step in developing the systems architecture for the Anti-Surface Warfare capability of Distributed Lethality is to determine the functions required to execute the operational activities described earlier. The functions for OA.2.4 Conduct ASUW are represented as a hierarchy (see Figure 19). In this hierarchy, the functions decompose until each function “implements” one of the operational activities. The CORE schema dictates that every operational activity be “implemented by” one or more functions, ensuring traceability through the model. For ASUW, this is the means of determining what functionalities the Adaptive Force Package must have in order to complete each of the events in the Anti-Surface Warfare FFBD. If one of the operational activities does not have a function that it is implemented by, then the AFP will not be able to complete that activity and will therefore fail its mission. Table 3 shows the relationship between each of OA.2.4 Conduct ASUW’s operational activities and the ASUW functions.

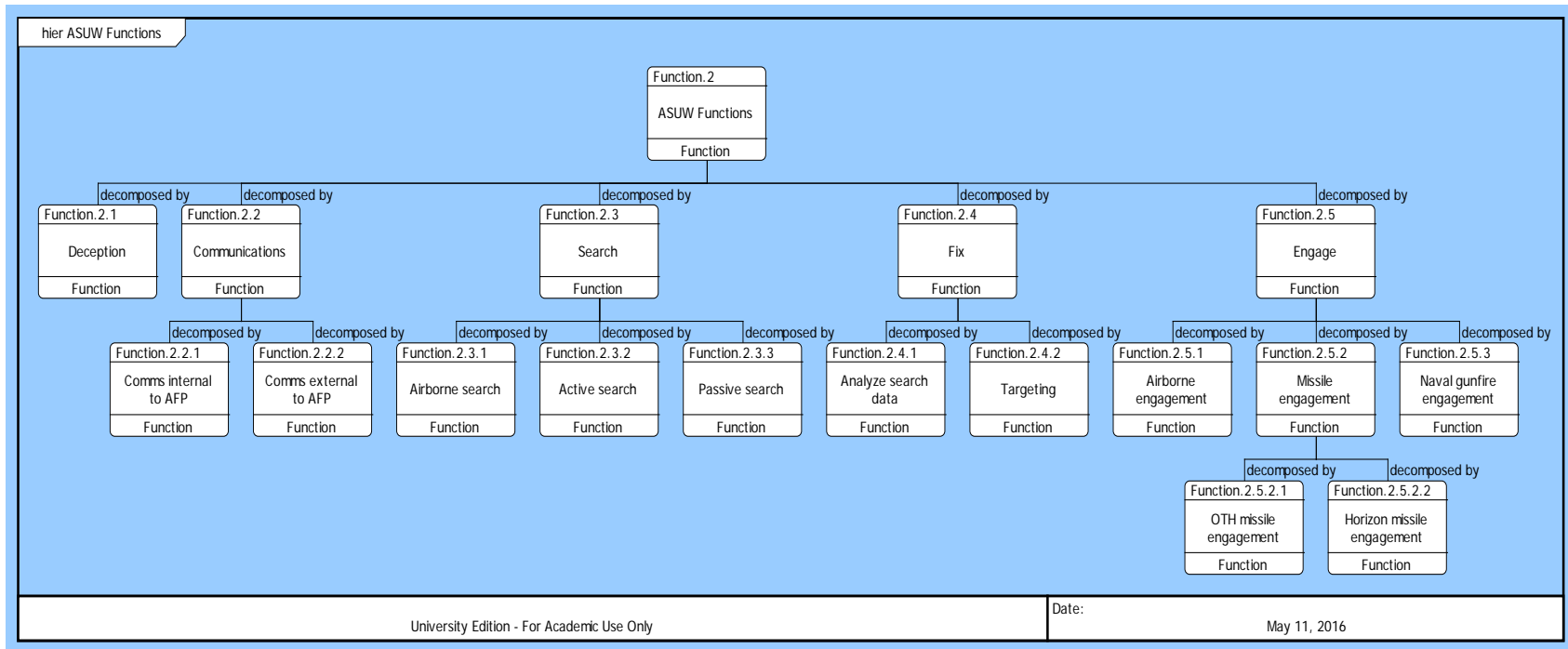

Figure 19. ASUW Functional Hierarchy.

Table 3. Mapping Operational Activities to Functions.

Number	Operational Activity	Implimented By
OA.2.4.1	EMCON	Function Function.2.1 Deception
OA.2.4.2	Deploy AFP	Function Function.2.2.1 Comms internal to AFP
OA.2.4.3	Search battlespace with embarked helos	Function Function.2.3.1 Airborne search
OA.2.4.4	Search battlespace with embarked UAS	Function Function.2.3.1 Airborne search
OA.2.4.5	Receive objective location from non-organic resource	Function Function.2.2.2 Comms external to AFP
OA.2.4.6	Search battlespace with organic sensors	Function Function.2.3.2 Active search Function Function.2.3.3 Passive search
OA.2.4.7	Search assessment	Function Function.2.4.1 Analyze search data
OA.2.4.8	Targeting	Function Function.2.4.2 Targeting
OA.2.4.9	Weapons pairing	Function Function.2.4 Fix
OA.2.4.10	Long-range ASCM	Function Function.2.5.2.1 OTH missile engagement
OA.2.4.11	Short-range ASCM	Function Function.2.5.2.2 Horizon missile engagement
OA.2.4.12	Naval gunfire	Function Function.2.5.3 Naval gunfire engagement
OA.2.4.13	Helicopter attack	Function Function.2.5.1 Airborne engagement
OA.2.4.14	UAS attack	Function Function.2.5.1 Airborne engagement
OA.2.4.15	BDA	Function Function.2.3.1 Airborne search Function Function.2.3.2 Active search Function Function.2.3.3 Passive search

1. Function.2.1 Deception

Deception is the function necessary to implement OA.2.4.1 EMCON, or emissions control. The ships of the AFP must have a plan to reduce or eliminate the electromagnetic signals that they produce and then have the ability to execute that plan.

2. Function.2.2 Communications

The ships of the AFP must be able to communicate with each other, their assigned assets like helicopters, the fleet, and any other non-organic units with which they are working. Function.2.2 Communications can be decomposed into Function.2.2.1 Comms internal to AFP and Function.2.2.2 Comms external to AFP. Comms internal to AFP is the function that implements OA.2.4.2 Deploy AFP, and Comms external to AFP is necessary in implementing OA.2.4.5 Receive objective location from non-organic resource (see Table 3).

3. Function.2.3 Search

The Search function is absolutely necessary for implementing several of the operational activities, but it must first decompose several levels. The first decomposition results in Function.2.3.1 Airborne search, Function.2.3.2 Active search, and Function.2.3.3 Passive search. Function 2.3.1 Airborne search is a functionality that

implements two operational activities: OA.2.4.3 Search battlespace with embarked helos and OA.2.4.4 Search battlespace with embarked UAS. CORE allows for a single function to implement more than one operational activity. In this case, even though the AFP commander has a distinct choice between using either helicopters or UAS to search, both options are airborne searches and can be one function. Function.2.3.2 Active search is necessary to implement part of OA.2.4.6 Search battlespace with organic sensors, while Function.2.3.3 Passive search implements the rest of OA.2.4.6 Search battlespace with organic sensors. Each of these three functions also implements OA.2.4.14 BDA. Any of these three functions can be used to determine the damage done to the enemy ships by the attack.

4. Function.2.4 Fix

Function.2.4 Fix is the command and decision function. This function and the two into which it decomposes, Function.2.4.1 Analyze search data and Function.2.4.2 Targeting, implement the three operational activities that follow the search activities. Function.2.4.1 Analyze search data is the ability to sift through the information gathered by the search in order to determine the location and composition of the enemy ships. This function implements OA.2.4.7 Search assessment. Function.2.4.2 Targeting implements OA.2.4.8 Targeting and is the ability of the combined combat systems of the AFP to accumulate enough information about the ships to effectively place weapons on them. Finally, Function.2.4 Fix is the ability of the combat systems and commander to determine the appropriate weapon with which to consummate the engagement. OA.2.4.9 Weapons pairing is implemented by Function.2.4 Fix.

5. Function.2.5 Engage

Function.2.5 Engage involves the different weapon options that the commander of the AFP can choose from in order to destroy the enemy ships. The Engage function needs to be decomposed in order to implement each of the operational activities that involve engaging the enemy. Function.2.5.1 Airborne engagement implements both OA.2.4.13 Helicopter attack and OA.2.4.14 UAS attack. Function.2.5.2 Missile engagement is decomposed by Function.2.5.2.1 OTH missile engagement and Function.2.5.2.2 Horizon

missile engagement. Function.2.5.2.1 OTH missile engagement is the function necessary to implement OA.2.4.10 Long-range ASCM for threats that are located at extreme ranges from the AFP. Function.2.5.2.2 Horizon missile engagement is the function necessary to implement OA.2.4.11 Short-range ASCM. Finally, Function.2.5.3 Naval gunfire engagement implements the relatively close-range OA.2.4.12 Naval gunfire.

D. COMPONENTS OF ASUW

In accordance with the CORE 9 Architecture Definition Guide, each function in an architecture is “allocated to” a component that is capable of conducting the function (Vitech Corporation 2013). For Distributed Lethality, this is the part of the architecture where the physical systems are finally built into the model. If done correctly, the model user can trace these components through the functions, operational activities, and capabilities all the way to one of the originally identified requirements. In this way, the model user sees how changing one or more of the components affects each level of the systems architecture. For the scope of this project, the author developed the components that “perform” the functions in Function.2.3 Search and Function.2.5 Engage of the over Function.2 ASUW functions. These components are designed to be built upon as new systems become available.

1. Components Performing Function.2.3.1 Airborne Search

The Airborne search function is allocated to the MH-60R sensors (see Figure 20). The MH-60R helicopter uses three main sensors as it searches for the enemy ships, so the component MH-60R sensors is “built from” three sub-components. These sensors are the AAS-44 Forward-Looking Infrared (FLIR) system, the ALQ-210 Electronic Support Measures system for passive surveillance, and the APS-147 surface search radar.

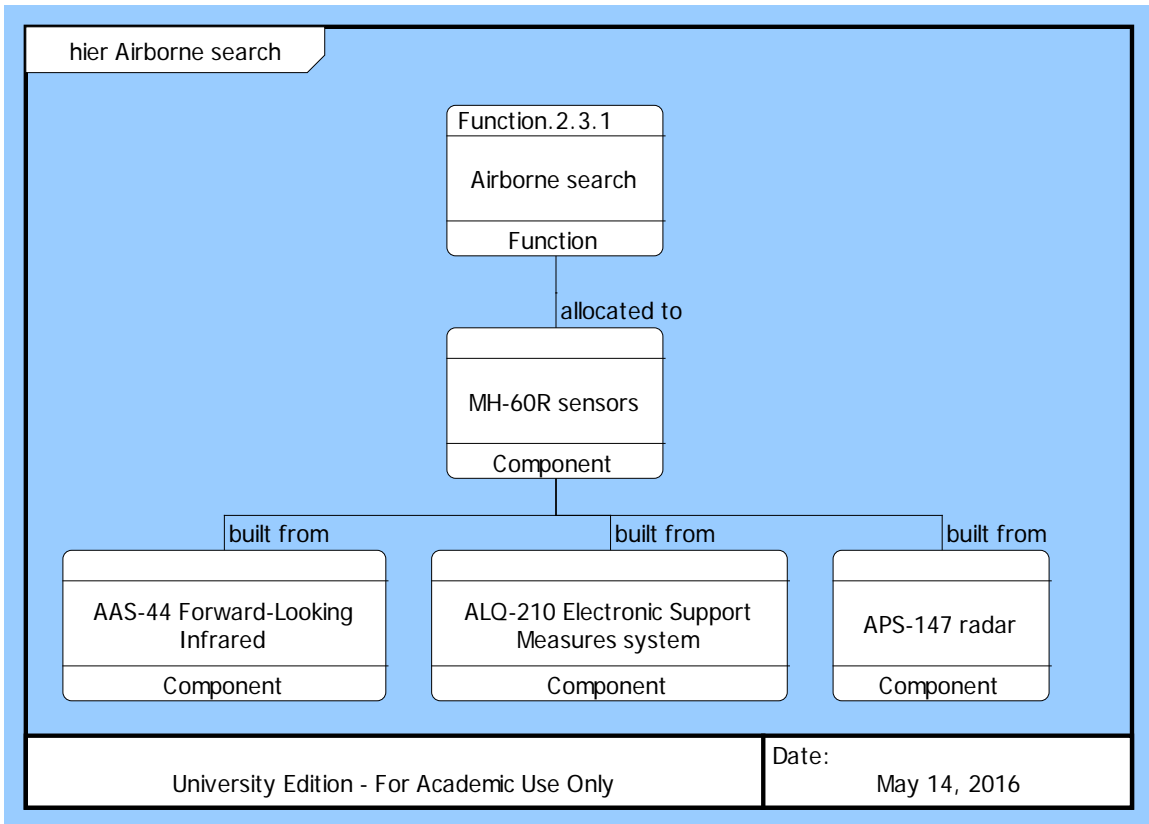

Figure 20. Components that Perform Function.2.3.1 Airborne Search.

2. Components Performing Function.2.3.2 Active Search

Function.2.3.2 Active search is allocated to the component Ship active sensors. Ship active sensors is then built from two sub-components: Air search radar and Surface search radar (see Figure 21). The component Air search radar is built from all of the air search radars that the ships of the AFP could have. These components include the SPY-1 radar of Arleigh Burke DDGs and Ticonderoga CGs, the SPY-3 of the Zumwalt DDGs, the Arleigh Burke Flight III's Air and Missile Defense Radar (AMDR), and the Sea Giraffe and TRS-3D radars carried by the LCS. The ships would use these radars to detect incoming missile threats and also search for aircraft associated with the enemy ships like helicopters or UAS. The Surface search radar component is built from sub-components that are the radars used by the same ships to search the surface for enemy ships.

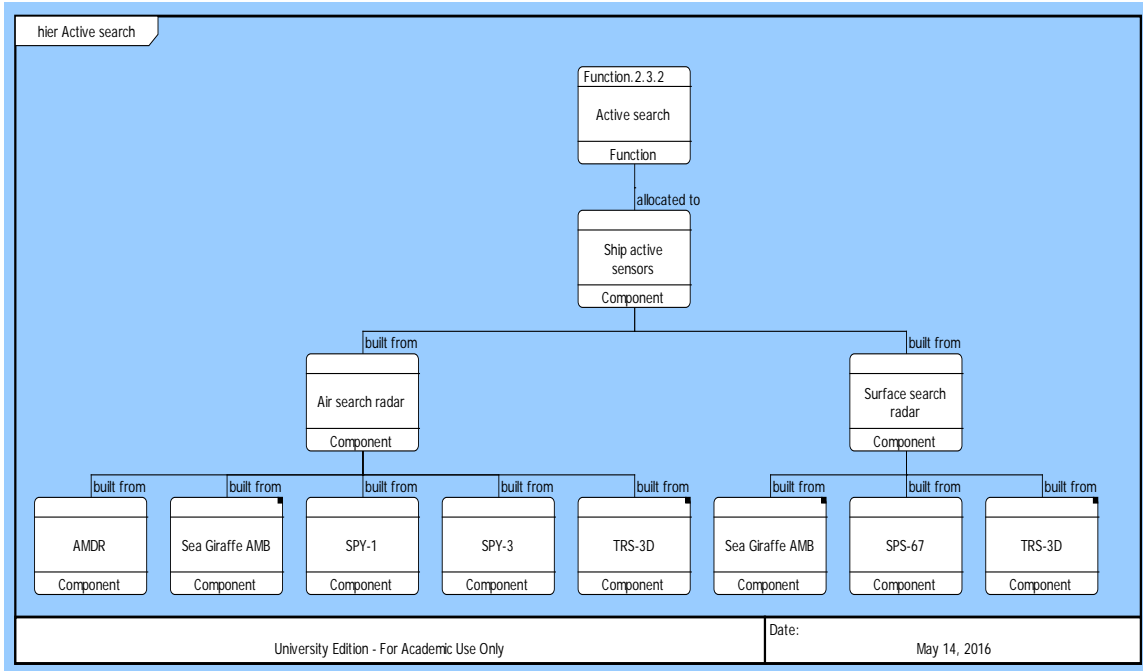

Figure 21. Components that Perform Function.2.3.2 Active Search.

3. Components Performing Function.2.3.3 Passive Search

Function.2.3.3 Passive search is allocated to component Ship passive sensors. This component is built from the sensors that can be used to search the battlespace passively and therefore do not require the ships of the AFP to expose themselves by using radars. The three components that Ship passive sensors are built from are Identification Friend or Foe (IFF), Signals exploitation, and the SLQ-32 Electronic Warfare Suite (see Figure 22). Each of these components are built from several more, but discussing these components carries the risk of exceeding the classification of this thesis.

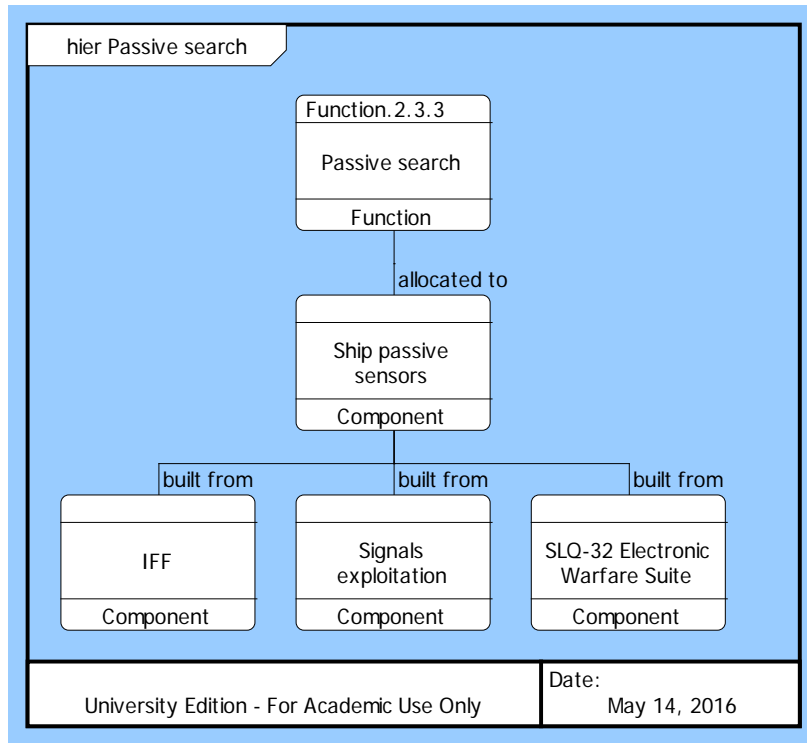

Figure 22. Components that Perform Function.2.3.3 Passive Search.

4. Components Performing Fuction.2.5.1 Airborne Engagement

The component capable of performing Function.2.5.1 Airborne engagement is a HELLFIRE missile launched from a MH-60R (see Figure 23). The MH-60R also can carry air launched torpedoes and machine gun, but neither of these weapons is appropriate for attacking an enemy surface ship capable of defending itself.

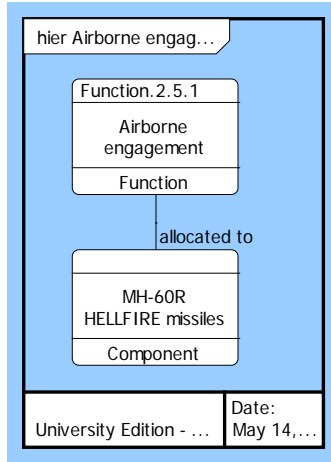

Figure 23. Components that Perform Function.2.5.1 Airborne Engagement.

5. Components Performing Function.2.5.2.1 OTH Missile Engagement

Function.2.5.2.1 OTH missile engagement is allocated to component Ship long-range missiles. The term “long-range” is a simplification of the possible spectrum of over-the-horizon engagements but presents a fundamental distinction in capability from engaging ships with missiles that are within the range of the horizon. For example, the Anti-Ship Tomahawk missile may have a range of up to 1,000 nautical miles while the Harpoon only has a range of 60 to 80 nautical miles, but as both can target and hit ships outside of a ship’s radar range, which is the horizon, the author classifies them as long-range missiles (Osborn 2016) (Carter 2015). Component Ship long-range missiles is built from four different types of missiles that are available to the fleet now or will be in the near future (see Figure 24). Component Anti-Ship Tomahawk is a modification of the land attack Tomahawk designed to greatly extend the offensive capability of surface combatants. Component Harpoon has been the Navy’s ASCM since the 1980s but has a limited range and is subsonic, making it easier for enemy defensive systems to defeat. Component LRASM is the Navy’s Long Range Anti-Ship Missile and is still in development. The LRASM will give surface combatants an extended range punch and will have advanced targeting capabilities (Osborn 2016). Component SM-6 is a new variant of the Standard Missile that has recently been proven to be effective against surface targets (Majumdar 2016). The SM-6 was designed primarily to kill missiles, so it

has a relatively small warhead, but it has the ability to target ships over the horizon and a speed in excess of Mach 3.5, making it a viable threat for disabling enemy warships.

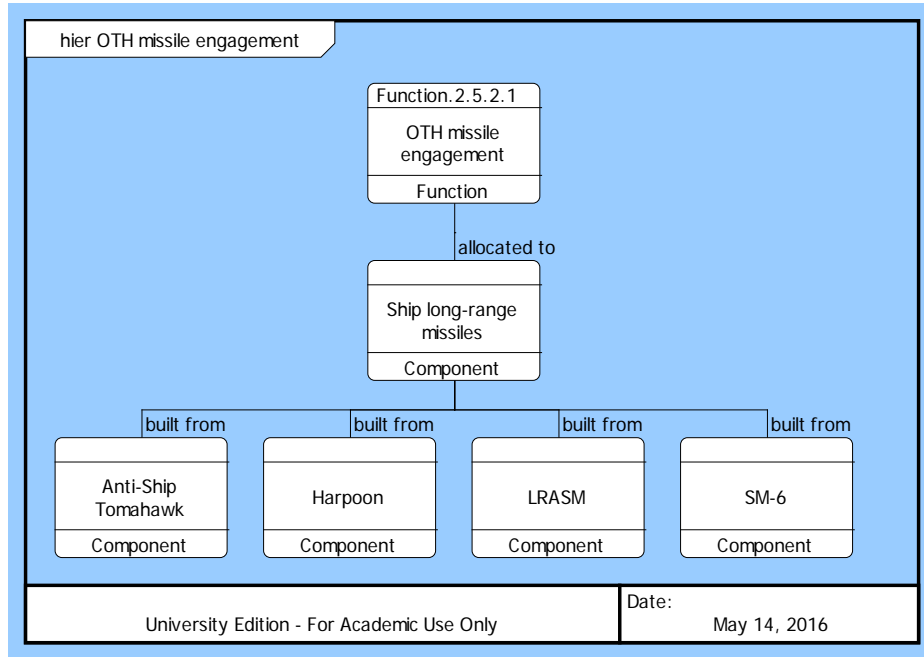

Figure 24. Components that Perform Function.2.5.2.1 OTH Missile Engagement.

6. Components Performing Function.2.5.2.2 Horizon Missile Engagement

Function.2.5.2.2 Horizon missile engagement is allocated to component Ship-short-range missiles. Ship short-range missiles is built from component Harpoon (short-range) and component SM-2 (see Figure 25). Harpoon (short-range) is the same missile as the long-range component but must be included here as it is a capable missile for use within horizon range. The SM-2, like the SM-6, is also primarily an anti-air missile, but it can be used against surface threats. The SM-2 does require continuous illumination from the launching ship's fire control system, meaning that it can only be used against ships inside of the horizon.

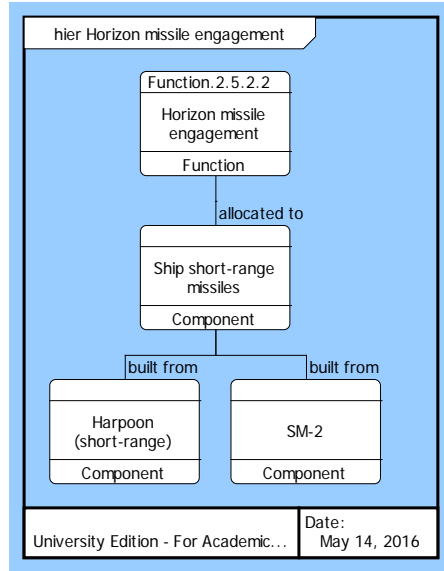

Figure 25. Components that Perform Function.2.5.2.2 Horizon Missile Engagement.

7. Components Performing Function2.5.3 Naval Gunfire Engagement

Function.2.5.3 Naval gunfire engagement is allocated to component Ship guns. Ship guns is built from all of the guns fielded by Navy surface combatants that can be used against enemy warships (see Figure 26). Component CG/DDG 51 5 in is the five inch gun carried by all U.S. Navy cruisers and Arleigh Burke class destroyers. The cruisers have two of the guns while the destroyers only have one. Component DDG 1000 155 mm is the new large gun carried by the Zumwalt class destroyer. The Zumwalts have two of the 155 millimeter guns, and although the guns were designed primarily for bombarding shore targets, they are capable of engaging surface targets as well. Component LCS 57 mm is the 57 millimeter gun carried by both classes of Littoral Combat Ship.

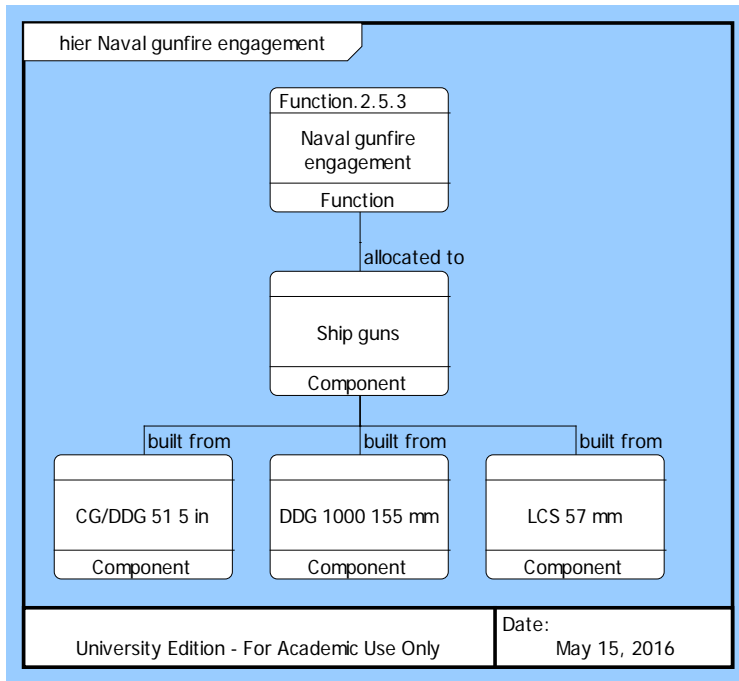

Figure 26. Components that Perform Function.2.5.3 Naval Gunfire Engagement.

V. CONCLUSION

Since the surface warfare leadership introduced the Distributed Lethality concept in early 2015, the surface navy has been working rapidly to codify and implement it. This new and unexplored system presented the opportunity for a systems architecture to be built from the beginning. This project attempted to build a section of this large architecture in order to demonstrate its usefulness as a developmental tool. This model creates a foundation for Distributed Lethality that can be used for future building, analysis, and simulation.

A. KEY POINTS

The architectural model for operational Distributed Lethality is large and extremely complex. The model presented in this thesis includes a complete top-level architecture, including the requirements and capabilities of operational Distributed Lethality. As each capability is the basis of an operational activity, and each operational activity is decomposed to possibly thousands of sub-operational activities, functions, and components, this model is far from complete. By working completely through capability CA.2.1.2 ASUW all the way to its associated components, the author has demonstrated the validity of model based systems engineering for building the architecture of such a complex system.

A primary concern in developing a systems architecture is ensuring traceability throughout the model. The traceability of the model ultimately dictates how useful the model is to users and decision makers. The usefulness of this model lies in the user having the ability to see how changing any part of the model can affect whether or not the system meets its defined requirements. For example, if a commander does not include a ship in an AFP that carries the component Anti-Ship Tomahawk, then the commander can use the traceability of the model to see what functions, operational activities, capabilities, and requirements cannot be accomplished (see Figure 27). In this case, not having component Anti-Ship Tomahawk directly affects the system's ability to execute the ASUW capability, which in turn affects three of Distributed Lethality's requirements.

Additionally, systems analysts using operational simulation can use measures of effectiveness and performance values to help them evaluate the ability of a component to perform a function. For example, a metric for Function.2.5.2.1 OTH missile engagement is the probability of the selected missile component, in this case the Anti-Ship Tomahawk, to affect a mission kill P_K on the target ship. Operational simulation can assign relative values to each of the components in a function in order to measure how effective the components would be at performing its function. Allowing the user to understand the connections between each part of a system is one of the main goals of systems architecture, and the sections of the model built for this thesis demonstrate this capability.

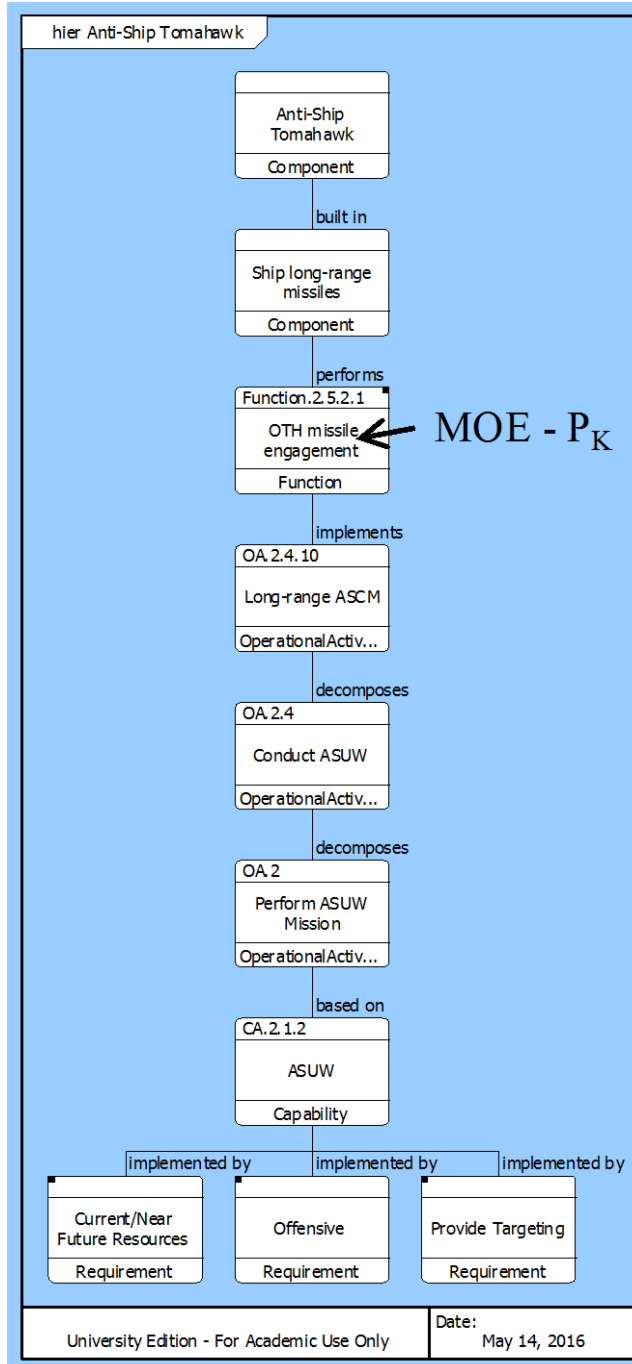

Figure 27. Mapping Component Anti-Ship Tomahawk through the Model to Requirements.

B. AREAS TO CONDUCT FURTHER RESEARCH

A project of this scope inevitably results in much room for further work. If the surface warfare leadership finds the parts of the model developed in this thesis useful, then there are several areas in which additional resources and time could be invested.

1. Model Expansion

The architecture built for this thesis only fully develops a model for one of the eight sub-capabilities. Each of the eight sub-capabilities is essentially a mission area, and the architecture for each should include a detailed flow of operational activities, the functions that implement the operational activities, and the components that perform the functions. If each of these models were fully built, then all of the components could be compared for redundancies. Additionally, if each of the sub-capabilities were fully built through the components then the components could be organized into the units that contain them. For example, an Arleigh Burke class destroyer contains components that perform functions across multiple sub-capabilities, but this physical modeling of each type of ship is not yet built into the architecture and would be a valuable tool.

The entire architecture is open, meaning that elements can be added as desired. This feature becomes useful if future study shows that additional requirements or capabilities should be included in the Distributed Lethality concept. A proficient CORE operator would have no problem modifying the model in order to accommodate additions or changes.

2. Support to Simulations

The systems architecture of Distributed Lethality is useful on its own as a detailed description of the system and its internal interactions, but it could also be used to power simulations. While CORE has basic simulation capabilities, a more detailed system is necessary to accurately model the complexities of a Distributed Lethality scenario. A systems such as Paul Beery's methodology for employing architecture in system analysis (MEASA) could be useful in converting the CORE model of Distributed Lethality into a

more usable simulation that could be used for more in depth analysis and potentially aid in wargaming Distributed Lethality (Beery 2016).

THIS PAGE INTENTIONALLY LEFT BLANK

LIST OF REFERENCES

- Anderson, Helene. 2010. “*System Engineering Challenges in Naval System of Systems.*” .
- Beery, Paul. 2016. “A Model Based Systems Engineering Methodology for Employing Architecture in System Analysis: Developing Simulation Models Using Systems Modeling Language Products to Link Architecture and Analysis.” PhD diss., Naval Postgraduate School.
- Business Wire. 2012. “BAE Systems Receives \$80 Million U.S. Navy Contract for Two Advanced Gun Systems.” *Business Wire*. November 28. Accessed May 16, 2016. <http://www.businesswire.com/news/home/20121128006055/en/BAE-Systems-Receives-80-Million-U.S.-Navy>.
- Carter, Claire. 2015. “Extraordinary Footage Emerges of Tomahawk Missile Punching a Hole Completely through a Moving Shipping Container during U.S. Navy Training Exercise.” *Daily Mail*. February 10. Accessed April 11, 2016. http://www.dailymail.co.uk/news/article-2947508/Extraordinary-footage-Tomahawk-missile-punching-hole-ship.html?ito=video_player_click.
- Defense Industry Daily Staff. 2014. “Next-Gen Naval Gunfire Support: The USA’s AGS & LRLAP.” *Defense Industry Daily*. February 23. Accessed April 20, 2016. <http://www.defenseindustrydaily.com/next-gen-naval-gunfire-support-the-usas-ags-lrlap-07171/>.
- Department of Defense. 2015. “DoD Architecture Framework.” Vers. 2.02.
- Eckstein, Megan. 2015. “Navy Studying Implications of Distributed Lethality in Wargames Series.” *USNI News*. July 9. Accessed April 11, 2016. <https://news.usni.org/2015/07/09/navy-studying-implications-of-distributed-lethality-in-wargames-series>.
- “”Filipoff, Dmitry. 2016. “Distributed Lethality and Concepts of Future War.” CIMSEC. January 4. Accessed April 15, 2016. <http://cimsec.org/tactical-doctrine-distributed-lethality/22286>.
- Freedberg, Sydney J. 2015. “‘If It Floats, It Fights’: Navy Seeks ‘Distributed Lethality.’” *Breaking Defense*. January 14. Accessed August 26, 2015. <http://breakingdefense.com/2015/01/if-it-floats-it-fights-navy-seeks-distributed-lethality/>.
- Hess, Paul. 2015. “VLS Rearming At-Sea (RAS).” Washington, DC: Office of Naval Research.

- Ho, Ben. 2016. "Fixing the US Navy's Anti-Surface Warfare Shortfall." *The Diplomat*. March 10. Accessed April 20, 2016. <http://thediplomat.com/2016/03/fixing-the-us-navys-anti-surface-warfare-shortfall/>.
- Kline, Jeffrey E. 2016. "A Tactical Doctrine for Distributed Lethality." CIMSEC. February 22. Accessed April 13, 2016. <http://cimsec.org/tactical-doctrine-distributed-lethality/22286>.
- LaGrone, Sam. 2016. "Navy Weighing Options for a Family of Future Surface Ships." *USNI News*. January 12. Accessed April 13, 2016. <https://news.usni.org/2016/01/12/navy-weighing-options-for-a-family-of-future-surface-ships>.
- Maier, Mark W., and Eberhardt Rechtin. 2009. *The Art of Systems Architecting*. 3rd ed. Boca Raton, FL: CRC Press.
- Majumdar, Dave. 2016. "How to Sink Warships: U.S. Navy Reveals Anti-Ship SM-6 Missile." *National Interest*. March 8. Accessed May 14, 2016. <http://nationalinterest.org/blog/the-buzz/how-sink-battleships-us-navys-anti-ship-sm-6-missile-15436>.
- McGrath, Bryan. 2015. "Opinion: U.S. Surface Warfare's Distributed Lethality Imperative." *USNI News*. August 25. Accessed September 2, 2015. <http://news.usni.org/2015/08/25/opinion-u-s-surface-warfares-distributed-lethality-imperative>.
- . 2016. "The U.S. Navy's Surface Force Just Got a Lot Deadlier." *War on the Rocks*. February 4. Accessed April 11, 2016. <http://warontherocks.com/2016/02/the-u-s-navys-surface-force-just-got-a-lot-deadlier/>.
- Myers, Meghann. 2015. "SECNAV unveils new name for LCS: the 'fast frigate'." *Navy Times*. January 15. Accessed August 31, 2015. <http://www.navytimes.com/story/military/2015/01/15/navy-secretary-mabus-littoral-combat-ship-fast-frigate/21805513/>.
- Naval Today Staff. 2011. "Makin Island Amphibious Ready Group Underway Following Singapore Port Visit." *Naval Today*. December 29. Accessed April 20, 2016. <http://navaltoday.com/2011/12/29/makin-island-amphibious-ready-group-underway-following-singapore-port-visit/>.
- Osborn, Kris. 2016. "Navy LRASM Missile Destroys Enemy Targets Semi-Autonomously; Lockheed Tests Ship-Fired Variant." *Scout*. January 19. Accessed May 14, 2016. <http://www.scout.com/military/warrior/story/1634058-navy-weapon-destroys-target-semi-autonomously>.

- Reed, John. 2011. "2,000 Tomahawks Fired in Anger." *Defense Tech*. August 4. Accessed April 20, 2016. <http://www.defensetech.org/2011/08/04/2000-tomahawks-fired-in-anger/>.
- Rowden, Thomas, Peter Gumataotao, and Peter Fanta. 2015. "Distributed Lethality." *U.S. Naval Institute Proceedings*. January 1. Accessed August 1, 2015. <http://www.usni.org/magazines/proceedings/2015-01/distributed-lethality>.
- U.S. Navy. 2011. "AUGUSTA BAY, Italy." U.S. Navy. March 24. Accessed April 13, 2016. http://www.navy.mil/view_image.asp?id=98980.
- Vitech Corporation. 2013. "Core Architecture Definition Guide (DoDAF v2.02)."
- Williams, Charlie. 2014. "Anti-Submarine Warfare (ASW) - The Heart of Surface Warfare." CIMSEC. April 22. Accessed April 25, 2016. <http://cimsec.org/anti-submarine-warfare-asw-heart-surface-warfare/11028>.
- Wills, Steven. 2015. "LCS: The Distributed Lethality Flotilla Combatant." CIMSEC. July 9. Accessed August 30, 2015. <http://cimsec.org/lcs-distributed-lethality-flotilla-combatant/17097>.

THIS PAGE INTENTIONALLY LEFT BLANK

INITIAL DISTRIBUTION LIST

1. Defense Technical Information Center
Ft. Belvoir, Virginia
2. Dudley Knox Library
Naval Postgraduate School
Monterey, California