

REPORT DOCUMENTATION PAGE

*Form Approved
OMB No. 0704-0188*

The public reporting burden for this collection of information is estimated to average 1 hour per response, including the time for reviewing instructions, searching existing data sources, gathering and maintaining the data needed, and completing and reviewing the collection of information. Send comments regarding this burden estimate or any other aspect of this collection of information, including suggestions for reducing the burden, to Department of Defense, Washington Headquarters Services, Directorate for Information Operations and Reports (0704-0188), 1215 Jefferson Davis Highway, Suite 1204, Arlington, VA 22202-4302. Respondents should be aware that notwithstanding any other provision of law, no person shall be subject to any penalty for failing to comply with a collection of information if it does not display a currently valid OMB control number.

PLEASE DO NOT RETURN YOUR FORM TO THE ABOVE ADDRESS.

1. REPORT DATE (DD-MM-YYYY)		2. REPORT TYPE		3. DATES COVERED (From - To)	
4. TITLE AND SUBTITLE				5a. CONTRACT NUMBER	
				5b. GRANT NUMBER	
				5c. PROGRAM ELEMENT NUMBER	
6. AUTHOR(S)				5d. PROJECT NUMBER	
				5e. TASK NUMBER	
				5f. WORK UNIT NUMBER	
7. PERFORMING ORGANIZATION NAME(S) AND ADDRESS(ES)				8. PERFORMING ORGANIZATION REPORT NUMBER	
9. SPONSORING/MONITORING AGENCY NAME(S) AND ADDRESS(ES)				10. SPONSOR/MONITOR'S ACRONYM(S)	
				11. SPONSOR/MONITOR'S REPORT NUMBER(S)	
12. DISTRIBUTION/AVAILABILITY STATEMENT					
13. SUPPLEMENTARY NOTES					
14. ABSTRACT					
15. SUBJECT TERMS					
16. SECURITY CLASSIFICATION OF:			17. LIMITATION OF ABSTRACT	18. NUMBER OF PAGES	19a. NAME OF RESPONSIBLE PERSON
a. REPORT	b. ABSTRACT	c. THIS PAGE			19b. TELEPHONE NUMBER (Include area code)

INSTRUCTIONS FOR COMPLETING SF 298

1. REPORT DATE. Full publication date, including day, month, if available. Must cite at least the year and be Year 2000 compliant, e.g. 30-06-1998; xx-06-1998; xx-xx-1998.

2. REPORT TYPE. State the type of report, such as final, technical, interim, memorandum, master's thesis, progress, quarterly, research, special, group study, etc.

3. DATES COVERED. Indicate the time during which the work was performed and the report was written, e.g., Jun 1997 - Jun 1998; 1-10 Jun 1996; May - Nov 1998; Nov 1998.

4. TITLE. Enter title and subtitle with volume number and part number, if applicable. On classified documents, enter the title classification in parentheses.

5a. CONTRACT NUMBER. Enter all contract numbers as they appear in the report, e.g. F33615-86-C-5169.

5b. GRANT NUMBER. Enter all grant numbers as they appear in the report, e.g. AFOSR-82-1234.

5c. PROGRAM ELEMENT NUMBER. Enter all program element numbers as they appear in the report, e.g. 61101A.

5d. PROJECT NUMBER. Enter all project numbers as they appear in the report, e.g. 1F665702D1257; ILIR.

5e. TASK NUMBER. Enter all task numbers as they appear in the report, e.g. 05; RFO330201; T4112.

5f. WORK UNIT NUMBER. Enter all work unit numbers as they appear in the report, e.g. 001; AFAPL30480105.

6. AUTHOR(S). Enter name(s) of person(s) responsible for writing the report, performing the research, or credited with the content of the report. The form of entry is the last name, first name, middle initial, and additional qualifiers separated by commas, e.g. Smith, Richard, J, Jr.

7. PERFORMING ORGANIZATION NAME(S) AND ADDRESS(ES). Self-explanatory.

8. PERFORMING ORGANIZATION REPORT NUMBER. Enter all unique alphanumeric report numbers assigned by the performing organization, e.g. BRL-1234; AFWL-TR-85-4017-Vol-21-PT-2.

9. SPONSORING/MONITORING AGENCY NAME(S) AND ADDRESS(ES). Enter the name and address of the organization(s) financially responsible for and monitoring the work.

10. SPONSOR/MONITOR'S ACRONYM(S). Enter, if available, e.g. BRL, ARDEC, NADC.

11. SPONSOR/MONITOR'S REPORT NUMBER(S). Enter report number as assigned by the sponsoring/monitoring agency, if available, e.g. BRL-TR-829; -215.

12. DISTRIBUTION/AVAILABILITY STATEMENT. Use agency-mandated availability statements to indicate the public availability or distribution limitations of the report. If additional limitations/ restrictions or special markings are indicated, follow agency authorization procedures, e.g. RD/FRD, PROPIN, ITAR, etc. Include copyright information.

13. SUPPLEMENTARY NOTES. Enter information not included elsewhere such as: prepared in cooperation with; translation of; report supersedes; old edition number, etc.

14. ABSTRACT. A brief (approximately 200 words) factual summary of the most significant information.

15. SUBJECT TERMS. Key words or phrases identifying major concepts in the report.

16. SECURITY CLASSIFICATION. Enter security classification in accordance with security classification regulations, e.g. U, C, S, etc. If this form contains classified information, stamp classification level on the top and bottom of this page.

17. LIMITATION OF ABSTRACT. This block must be completed to assign a distribution limitation to the abstract. Enter UU (Unclassified Unlimited) or SAR (Same as Report). An entry in this block is necessary if the abstract is to be limited.

RT 184: Electronic Survivability in Harsh Environments

Pradeep Lall

John and Anne MacFarlane Endowed Professor
Director, NSF-CAVE3 Electronics Research Center
Technical Council and Governing Council of NextFlex

Auburn University
Auburn, AL 36849
(O) 334-844-3424

Email: lall@auburn.edu

cave³

NSF Center for Advanced Vehicle and Extreme Environment Electronics



Measurement of Interfacial Fracture Toughness and Cohesive-Zone Models of Potting Compounds with FR4 PCBs

K. Dornala, P. Lall

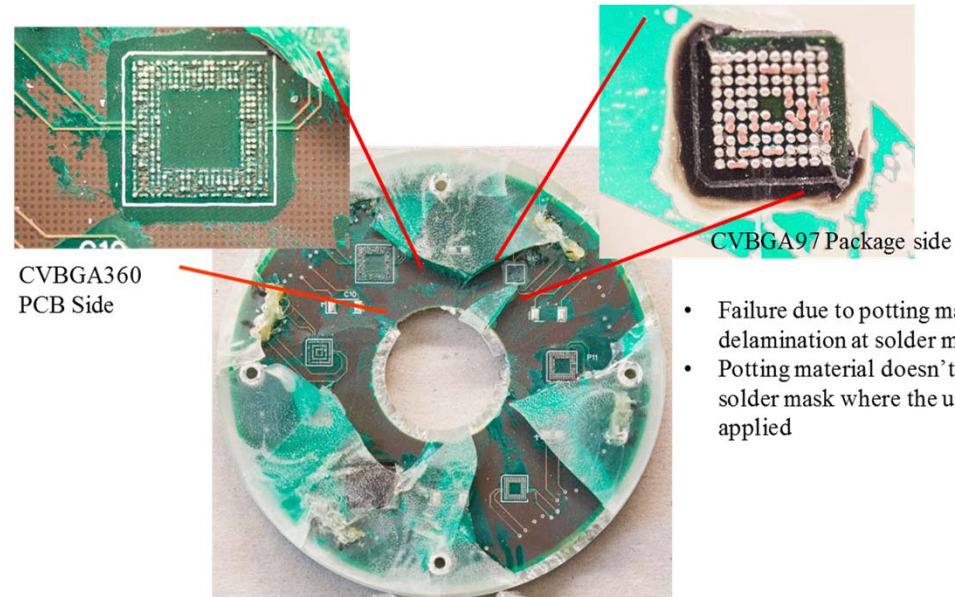

*Epoxy-A potting material failure @
25,000g mechanical shock*

- ❑ Determination of the fracture parameters such as fracture toughness and strain energy release rate under out-of-plane deformation
- ❑ Effect of process parameters such as cure schedule and temperature on fracture toughness and characterize the mechanics of interface delamination of potting-PCB interface.
- ❑ Create modeling framework for delamination prediction.

cave³

NSF Center for Advanced Vehicle and Extreme Environment Electronics

AU AUBURN
UNIVERSITY

Introduction

- ❑ Electronic components operating under extreme thermo-mechanical stresses are often protected underfills and potting encapsulation to mitigate the thermal and vibration shock loads.
- ❑ Encapsulation of the PCB with epoxy resin provides complete insulation for the unit thereby combining good electrical properties with excellent mechanical protection.
- ❑ In military and defense applications these components are often subjected to mechanical shock loads of 50,000g and are expected to perform with reliability.
- ❑ The cured potting materials are prone to interfacial delamination under bending loading which in turn potentially cause failures in the package interconnects.

Failure Modes at potting-PCB interface under 25,000g shock

Pristine epoxy potted test PCBs

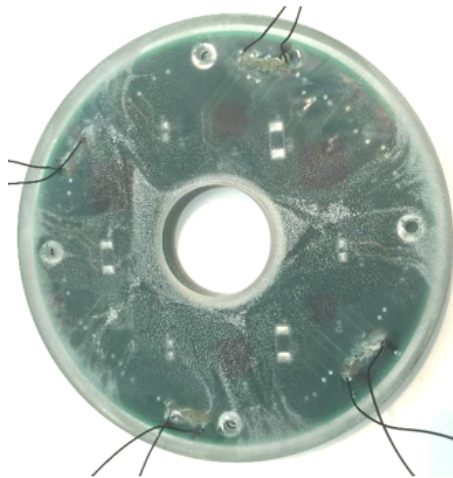

Epoxy Compound A



Epoxy Compound B

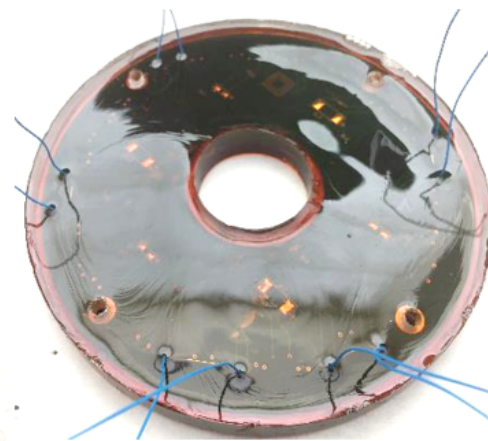

Epoxy Compound C

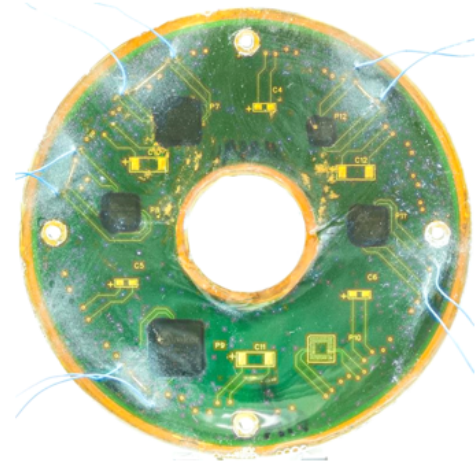
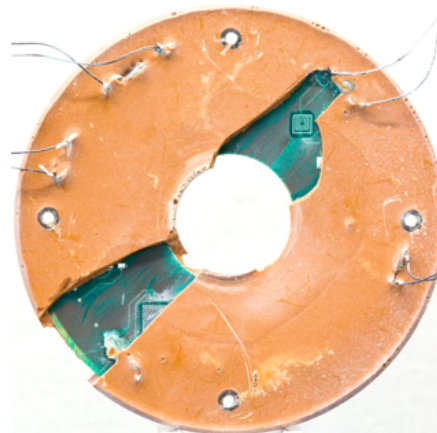
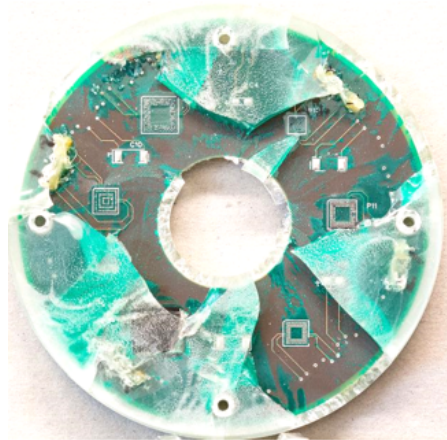

High-g shock tested PCBs at 25,000g

Test Vehicle

Specimen Preparation

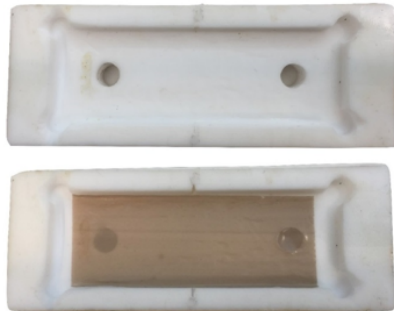

Teflon mold with release holes

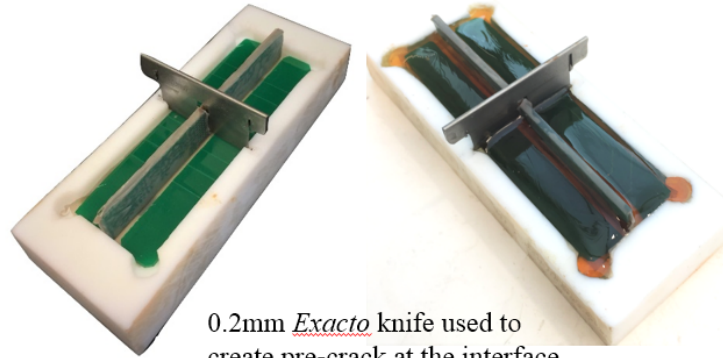

0.2mm *Exacto* knife used to create pre-crack at the interface



Epoxy-A/PCB cured sample

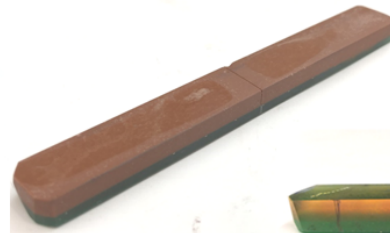

Epoxy-B/PCB cured sample

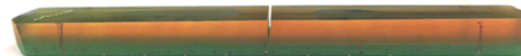

Epoxy-C/PCB cured sample

- Epoxy material-A is a clear two part system. Stiffer cured material of the three.
- Epoxy material-B is a brown color two-part system with a hardness value between A and C.
- Epoxy material-C is an amber color three part system. Softer cured material .

Potting System	Tg (°C)	Density (Kg/m3)	Elastic Modulus (GPa)	Max Elongation %	Hardness
A	122	1024	2.81	4	ShoreD 85
B	60	1320	1.42	12	ShoreD 72
C	~85	936	0.315	80	ShoreD 35-45

Experiment setup

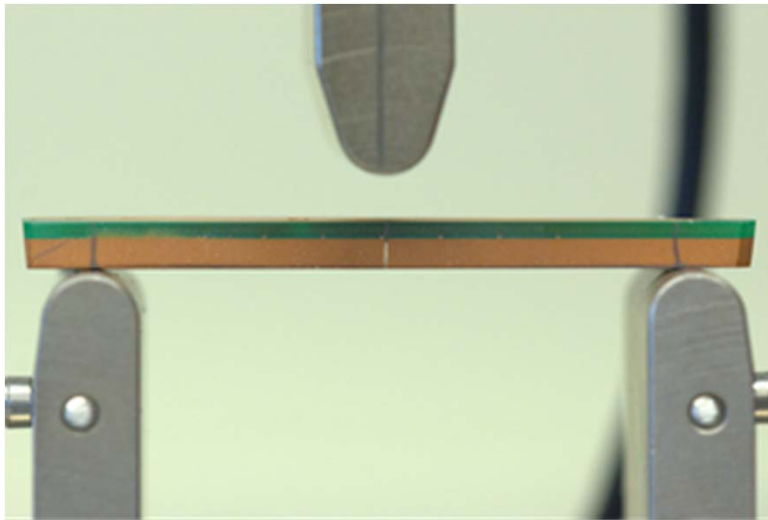

PCB-Epoxy potting sample loaded on the instron three point bend fixture

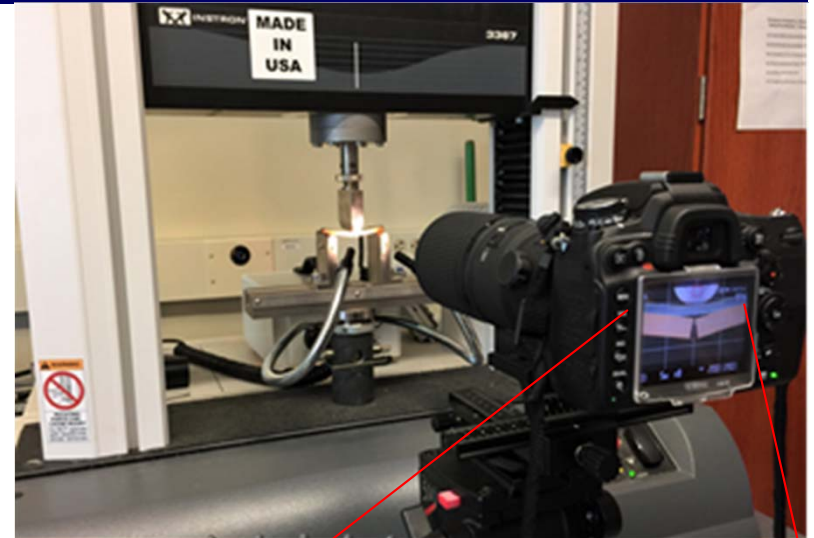

Video recording setup

Cure Time	7Day	2hr	2hr	2hr	2hr
Cure Temp	25°C	45°C	75°C	95°C	125°C
Epoxy A	X	X	X	X	X
Epoxy C	X	X	X	X	X

Cure Time	7Day	1hr	1hr	1hr	1hr
Cure Temp	25°C	45°C	75°C	95°C	125°C
Epoxy B	X	X	X	X	X

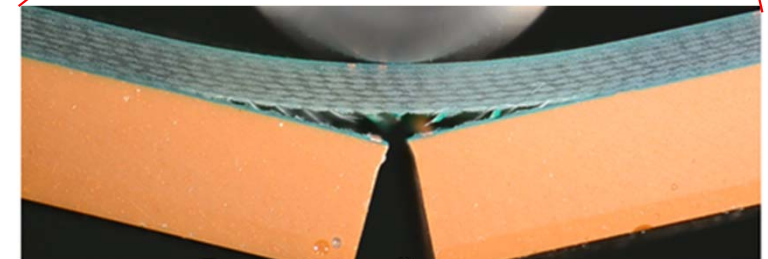

Flexure rate: 2mm/min

cave³

NSF Center for Advanced Vehicle and Extreme Environment Electronics



PCB-epoxy potting bi-material 3-point bend test

Epoxy-A/PCB Potting 3-point bend test

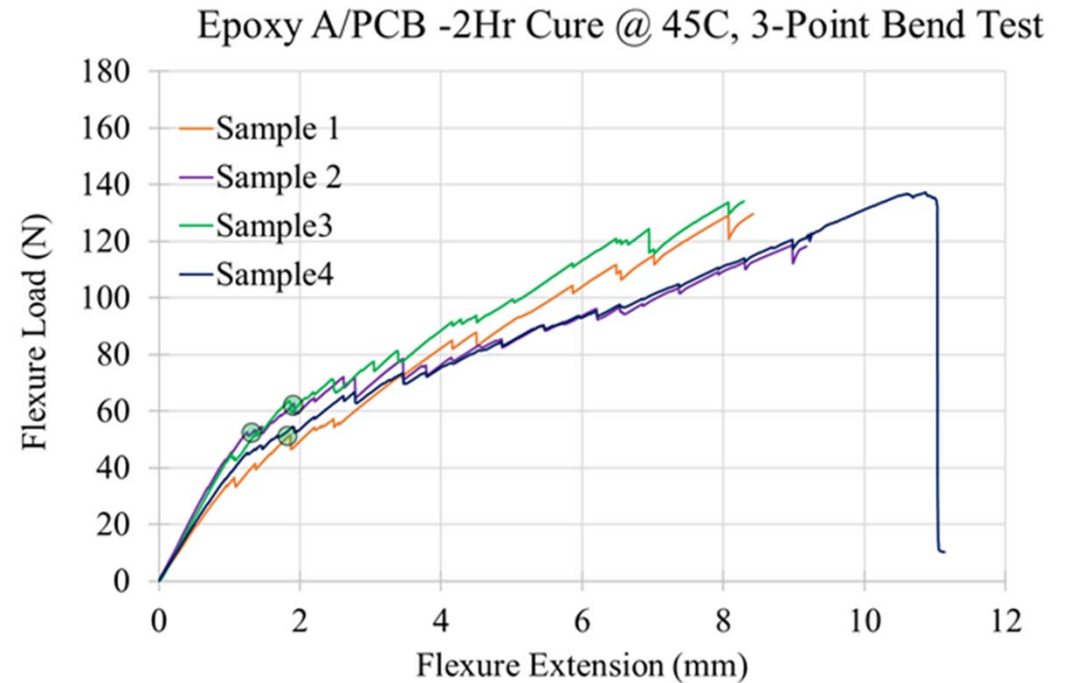
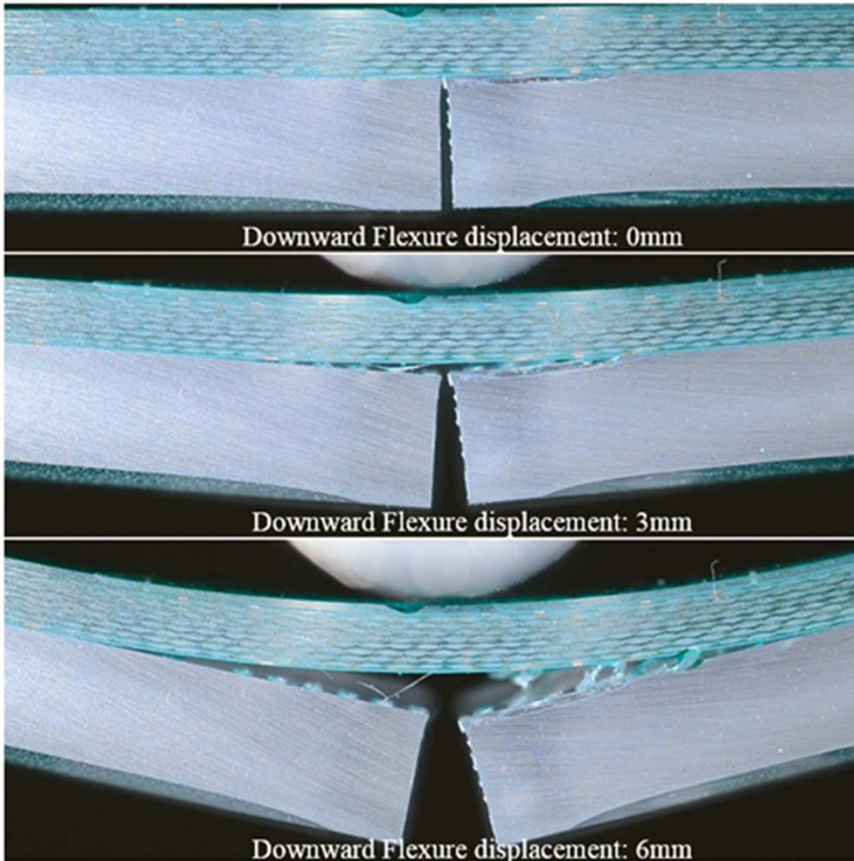

PCB-epoxy potting bi-material 3-point bend test

Effect of cure temperature @ 2hr cure time

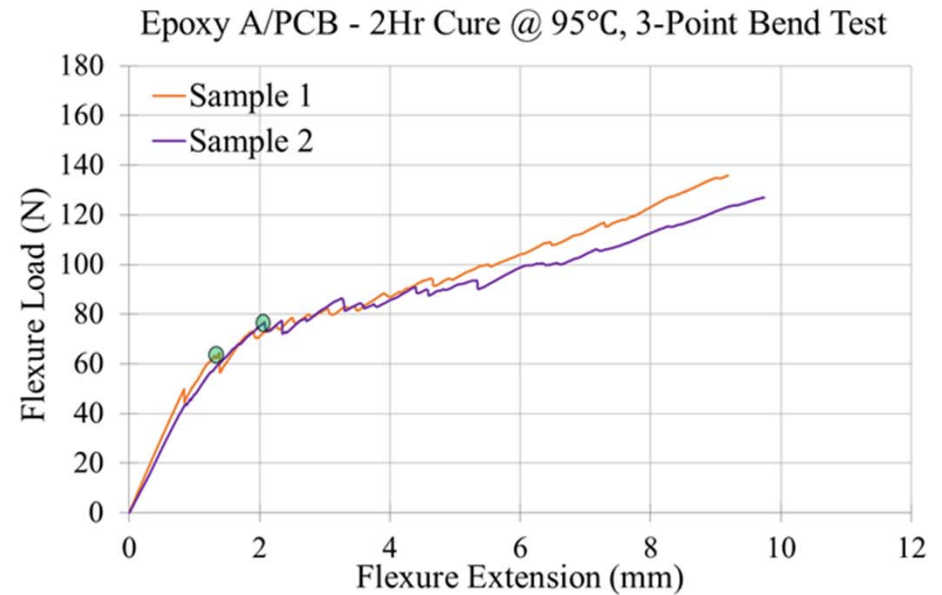
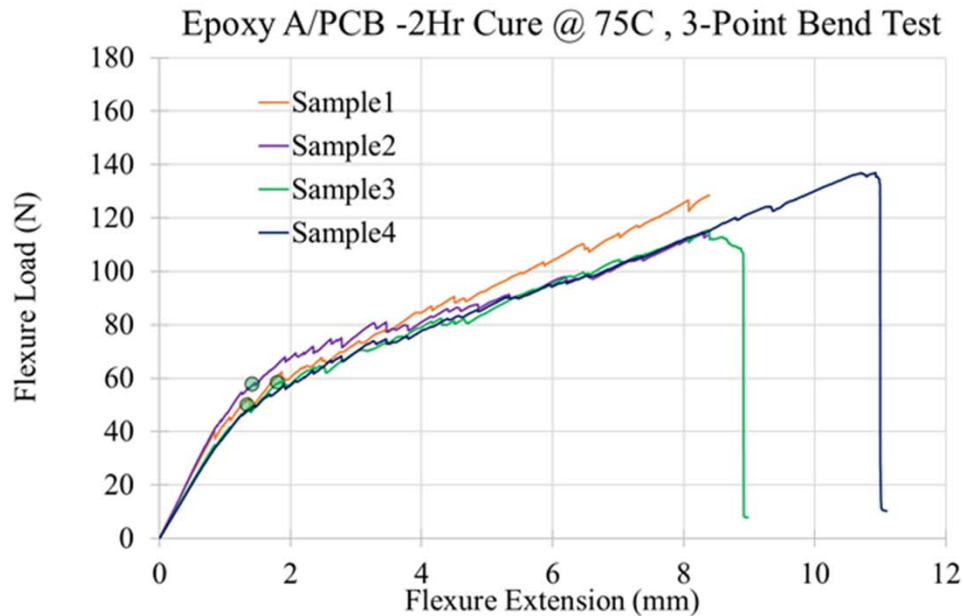

PCB-epoxy potting bi-material 3-point bend test

Epoxy-B/PCB potting 3-point bend test

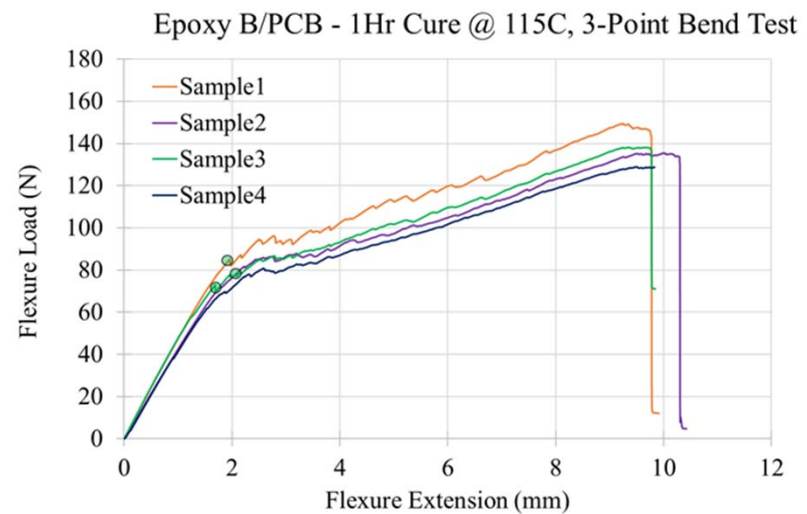
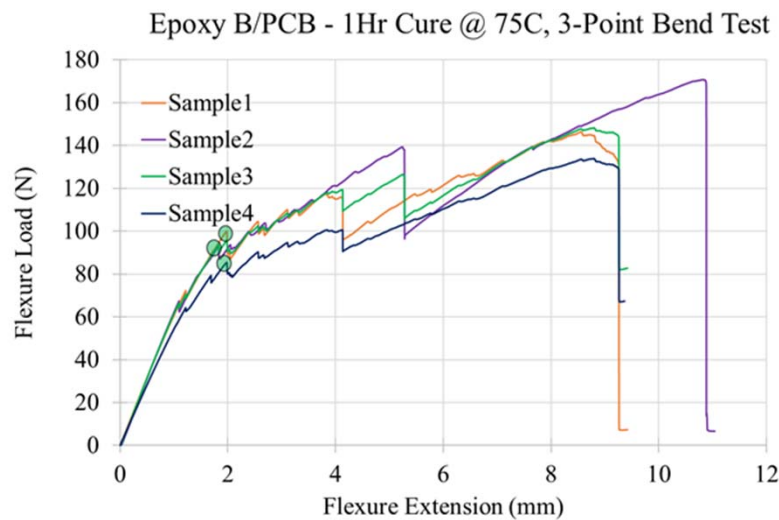
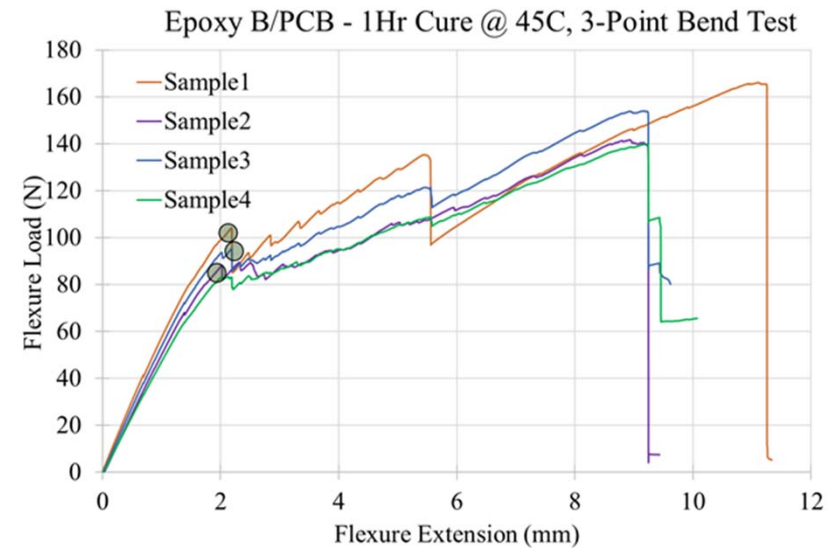
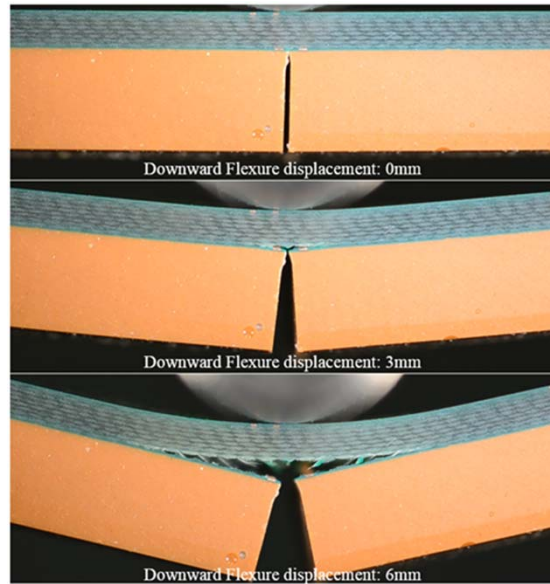

cave³

NSF Center for Advanced Vehicle and Extreme Environment Electronics



AUBURN
UNIVERSITY

PCB-epoxy potting bi-material 3-point bend test

Epoxy-C/PCB potting 3-point bend test

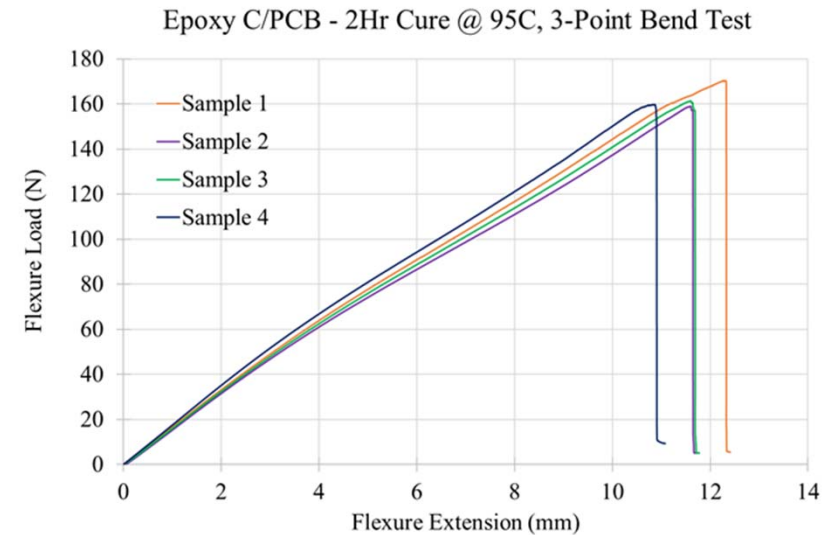
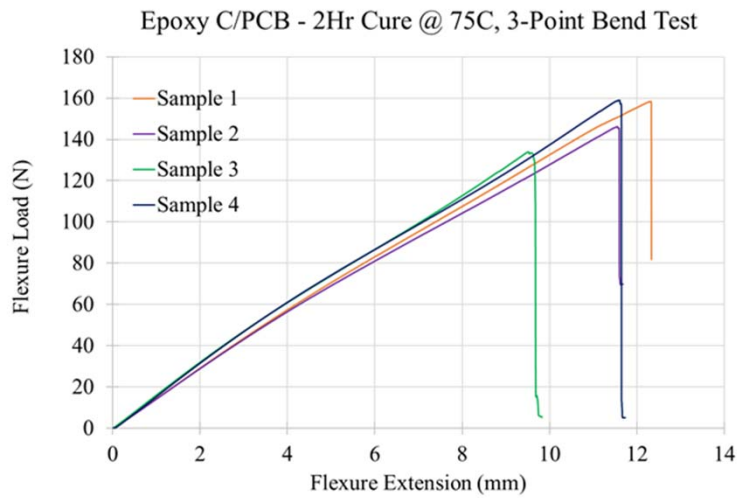
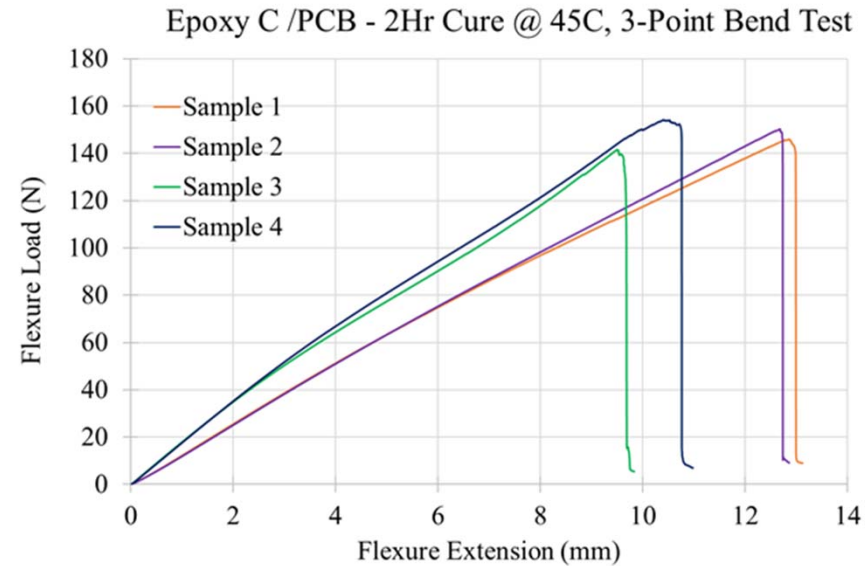
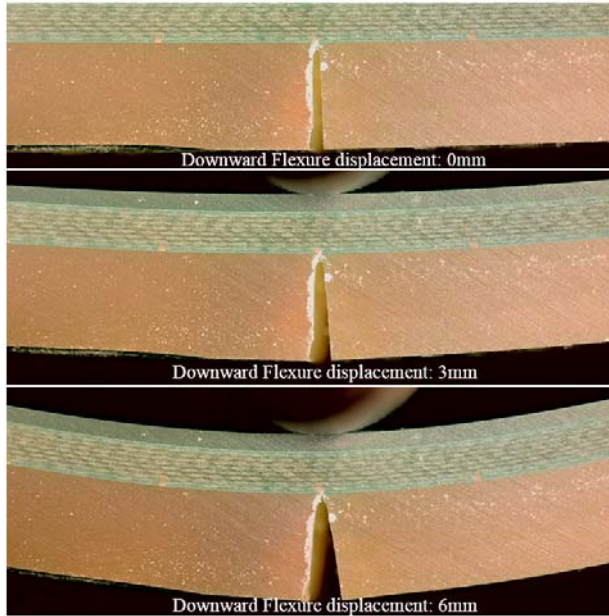

Fracture toughness calculations

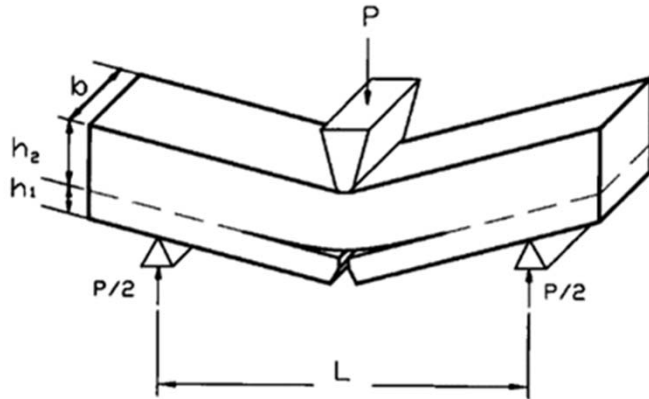

$$G_s = \frac{M^2(1 - \nu^2)}{2E} \left(\frac{1}{I_2} - \frac{1}{I_1} \right)$$

$$I_c = \frac{h_1^3}{12} + \frac{h_2^3}{12} + h_1 h_2 (h_1 + h_2) / 4, \quad I_2 = \frac{h_2^3}{12}$$

$$K_c = \left(\frac{G_c E}{1 - \nu^2} \right)^{1/2}, \quad M = Pl/4b$$

Cure Temperature	Fracture Toughness K_C (Mpa.m ^{1/2})		
	Epoxy A Specimen	Epoxy B Specimen	Epoxy C Specimen
25°C	2.40	3.40	6.38
45°C	2.45	4.96	6.58
75°C	2.76	4.75	6.77
95°C	3.24	4.11	6.92
115°C	N/A	3.96	N/A
125°C	3.10	N/A	6.63

Pozuelo, M., et al. "Fracture toughness for interfacial delamination of Cr-Mo steel multilayer laminate." *Materials Science and Technology* 25.5 (2009): 632-635.

Fracture toughness vs Cure temperature

Epoxy-A/PCB Bimaterial Interface Fracture Toughness w.r.t Cure Temperature

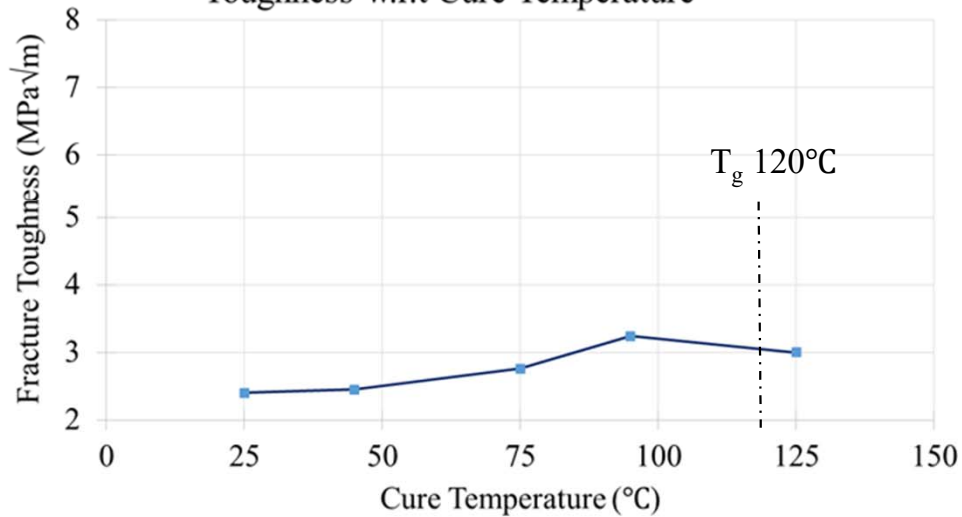

Epoxy-B/PCB Bimaterial Interface Fracture Toughness w.r.t Cure Temperature

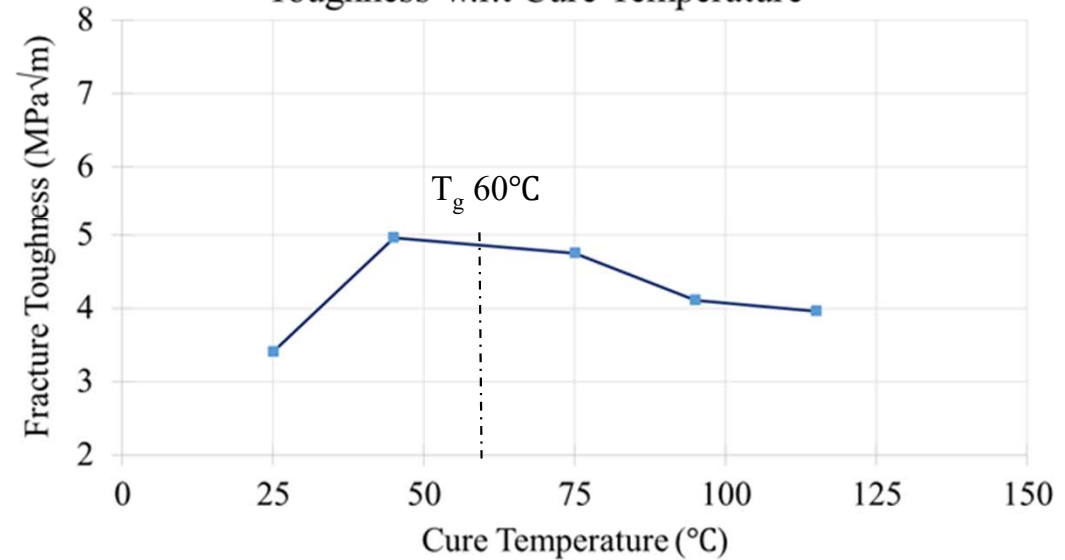

Epoxy-C/PCB Bimaterial Fracture Toughness w.r.t Cure Temperature

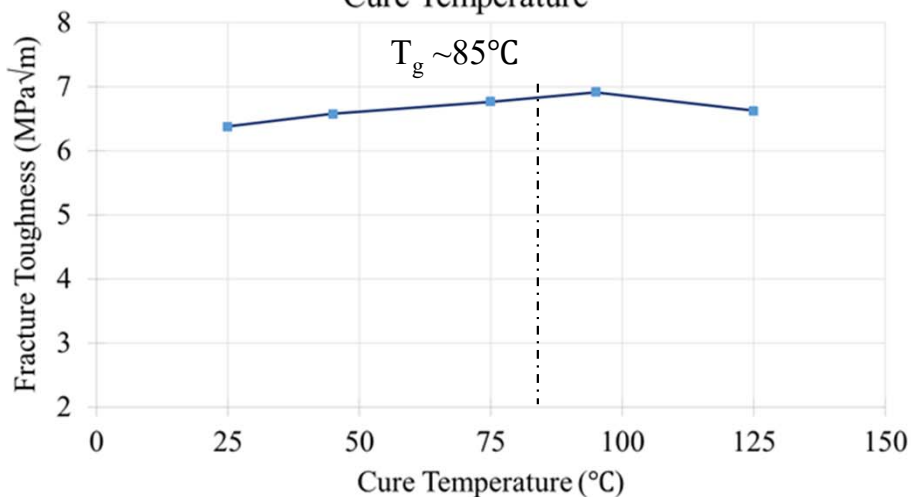

FE Predictions

ABAQUS-Standard Model

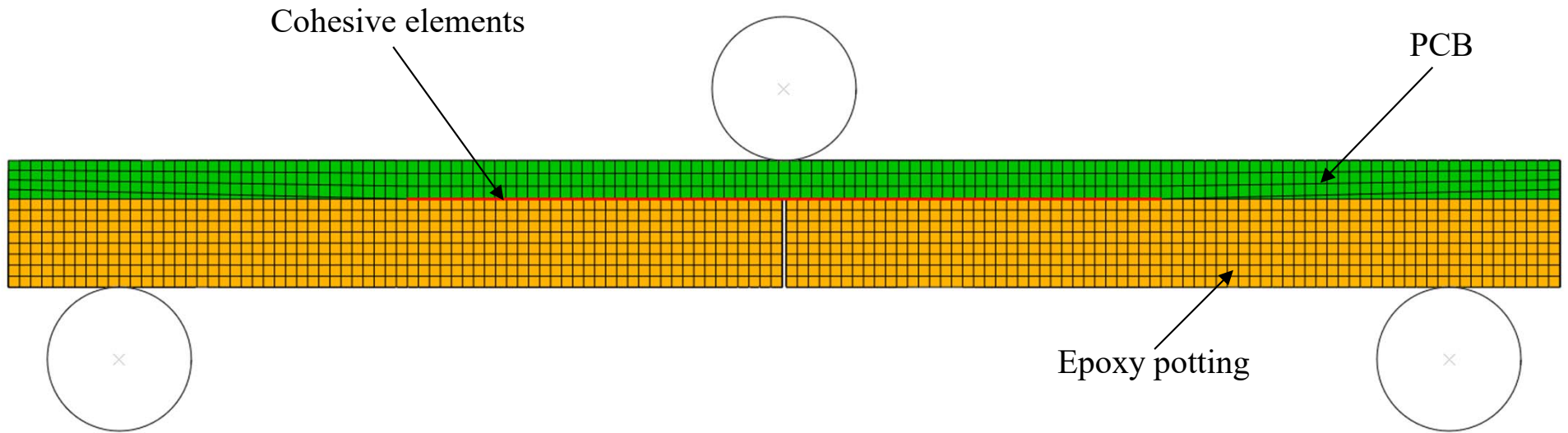

Linear elastic-traction separation constitutive law

Material	Element Type
PCB	C3D8
Epoxy	C3D8
Cohesive	COH3D8
Rigid Pins	R3D4

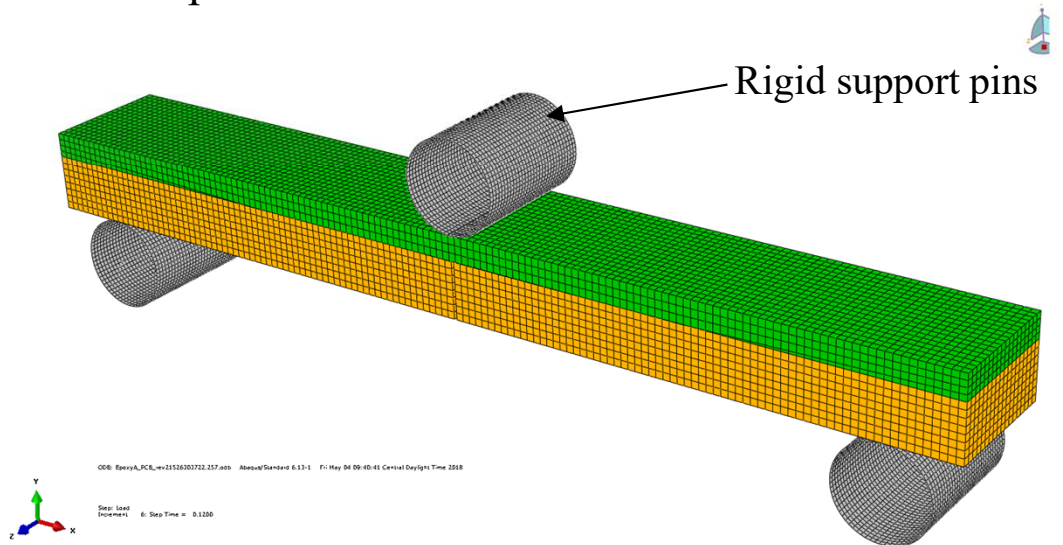

FE Predictions

Epoxy-A potting PCB 3-point bend test

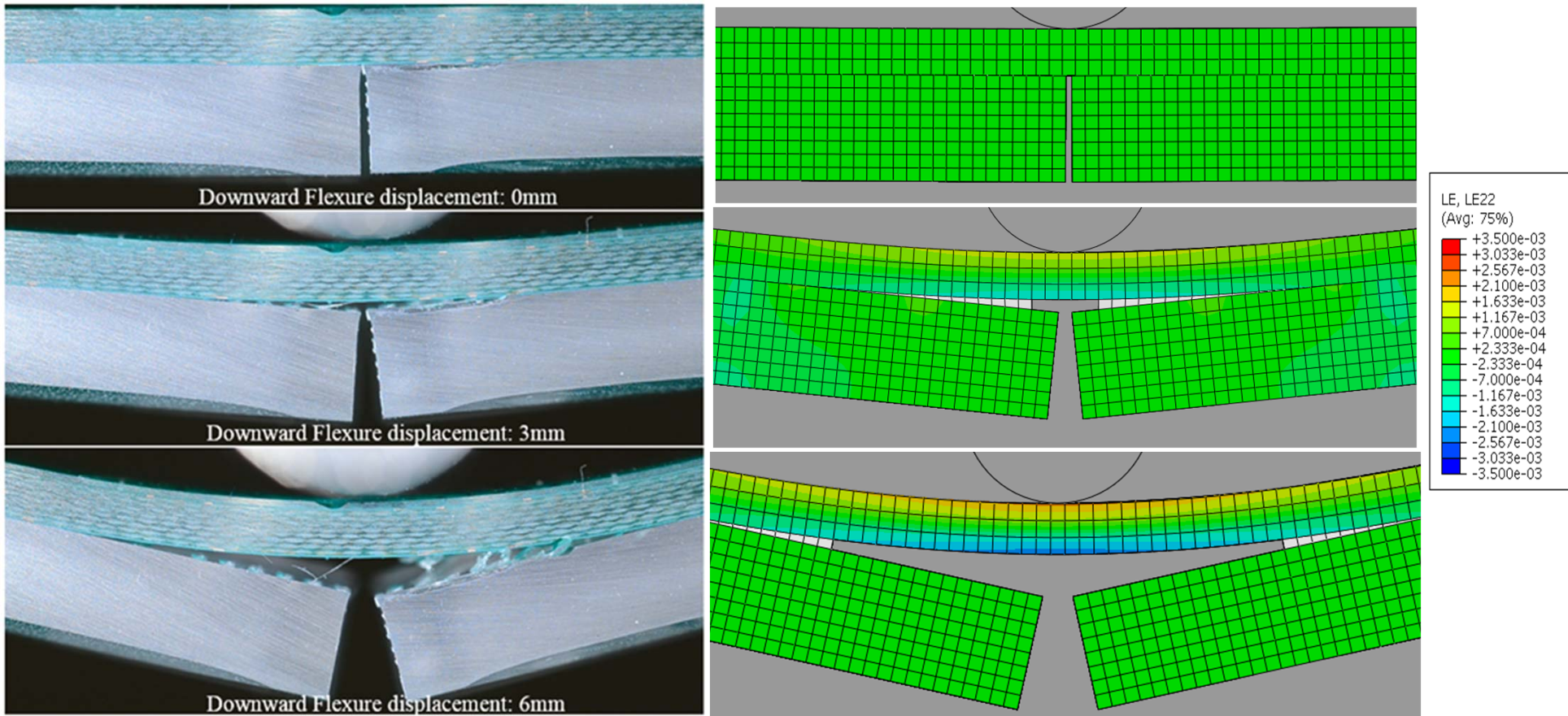

FE Predictions

Epoxy-B potting PCB 3-point bend test

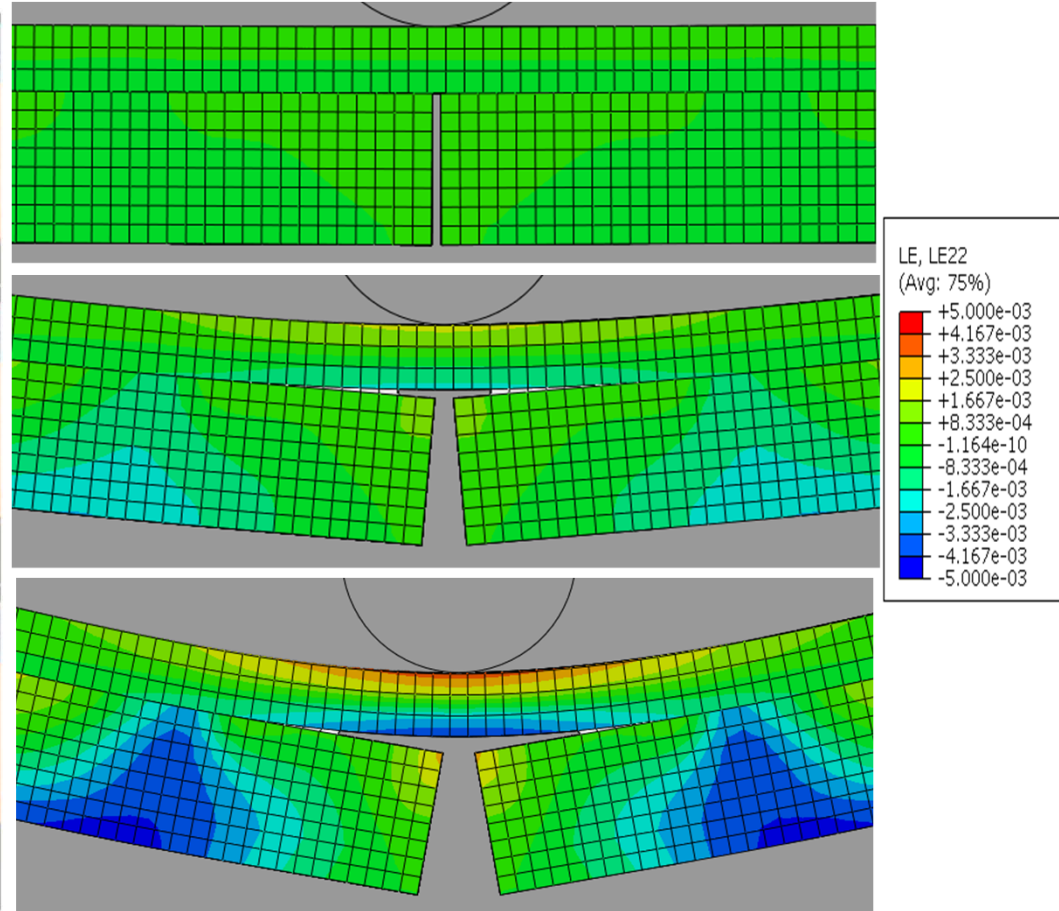
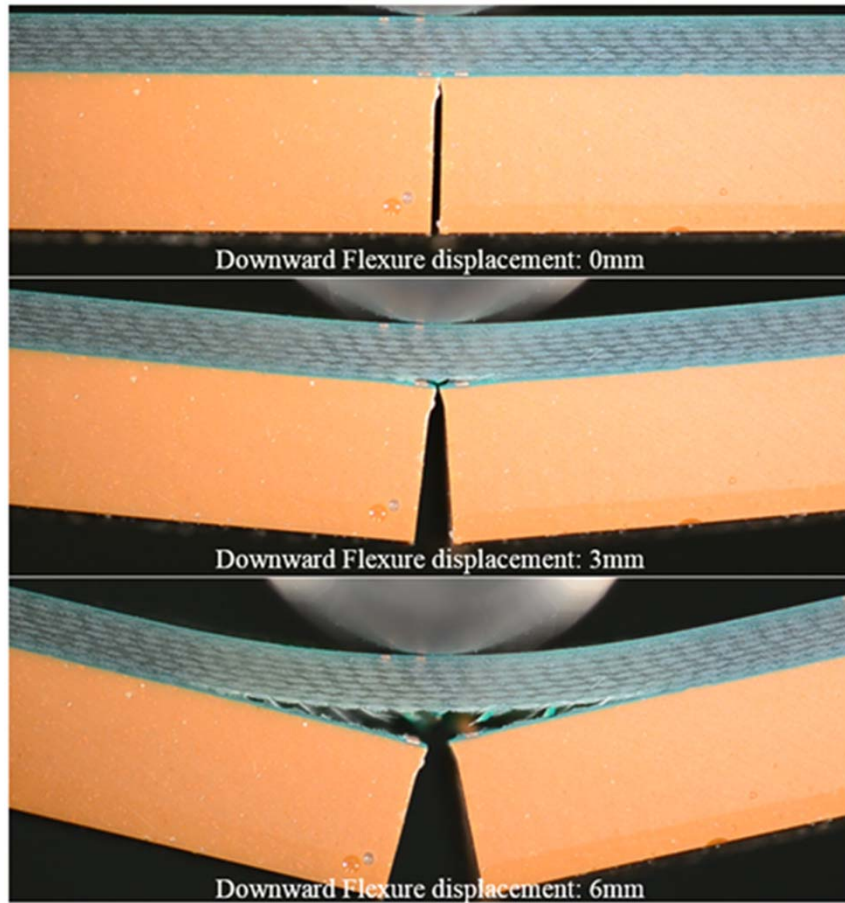

FE Predictions

Epoxy-C potting PCB 3-point bend test

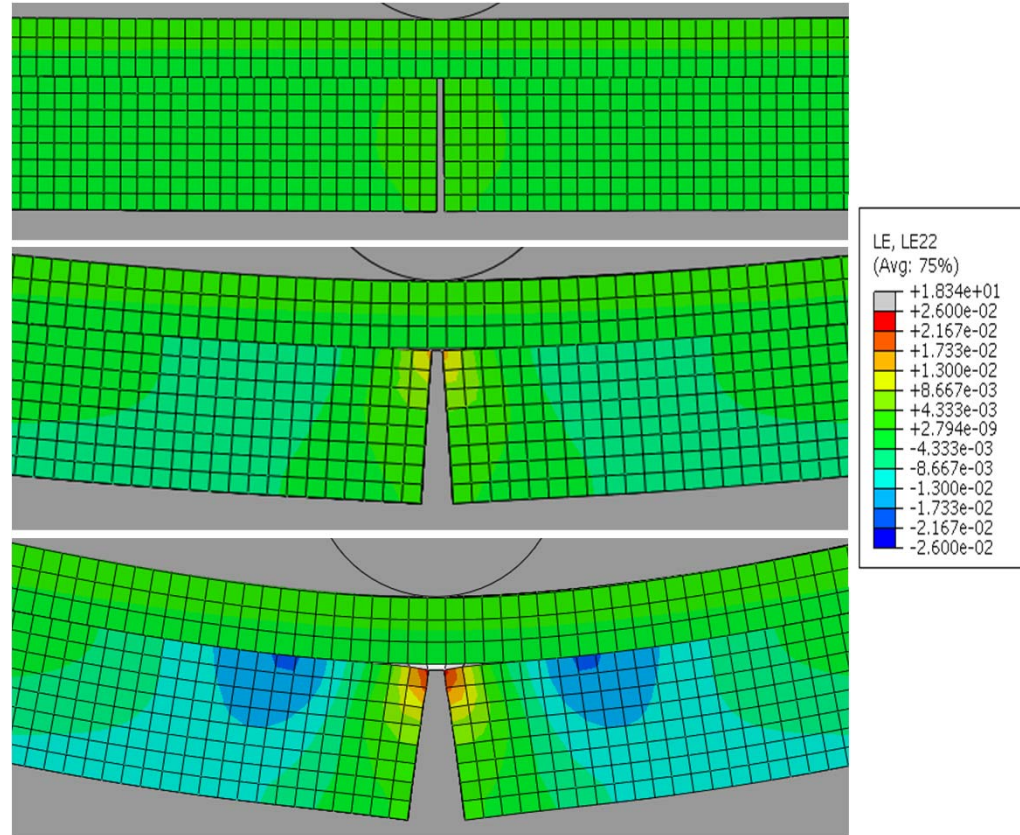
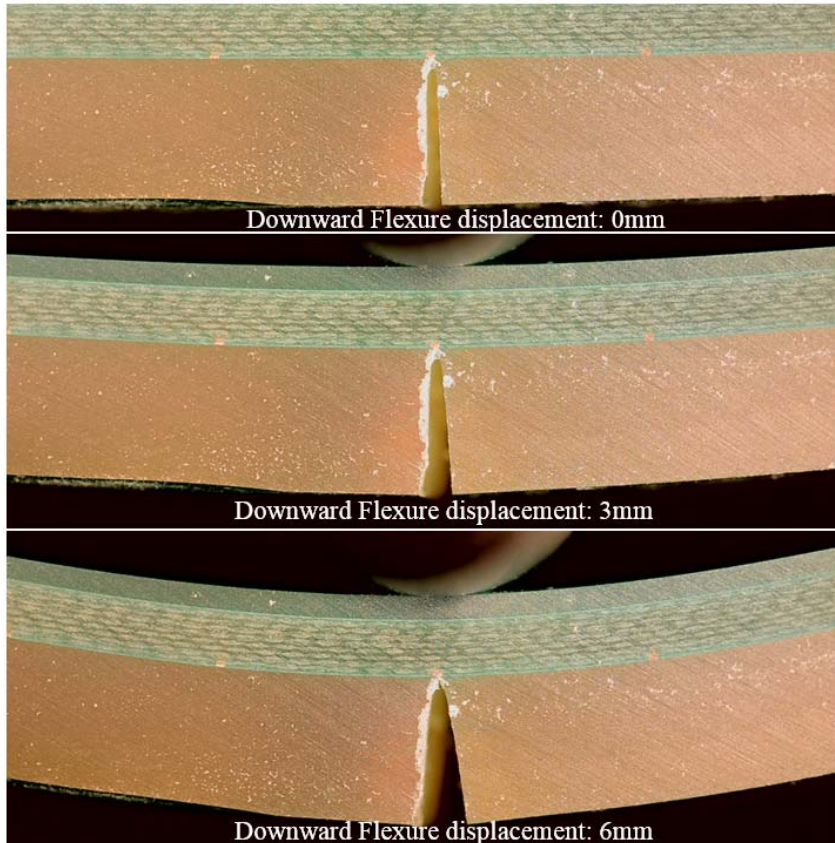

FE constitutive behavior

- The constitutive behavior of the cohesive elements is characterized by the traction-separation law of fracture mechanics.
- It takes into account the amount of energy required to create new surface i.e, interfacial crack.
- In the damage process, failure of package occurs due to degradation of the material stiffness. The softening behavior of cohesive zone after the damage initiation criterion is satisfied, is defined using the damage evolution law.
- The damage evolution law describes the rate at which the material stiffness is degrades once the corresponding initiation criterion is reached.

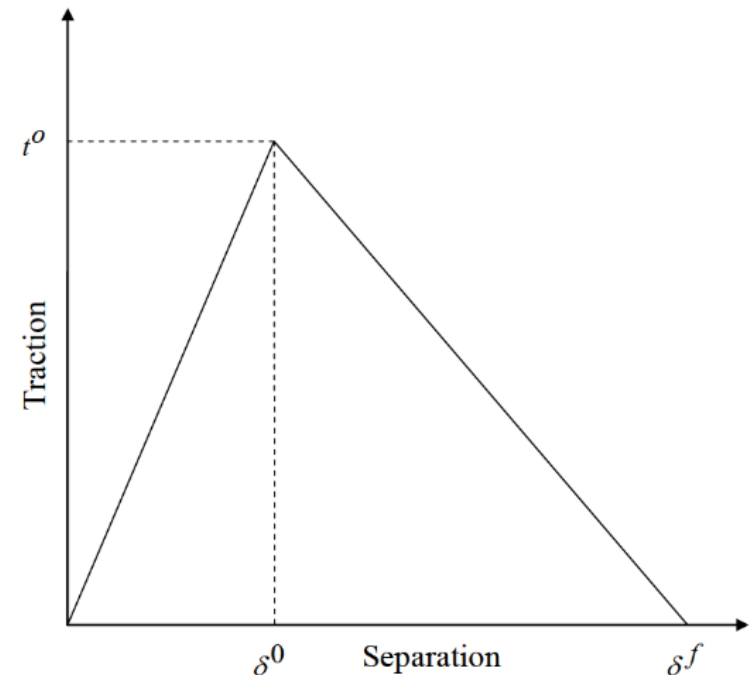

Modeling Cohesive Layer

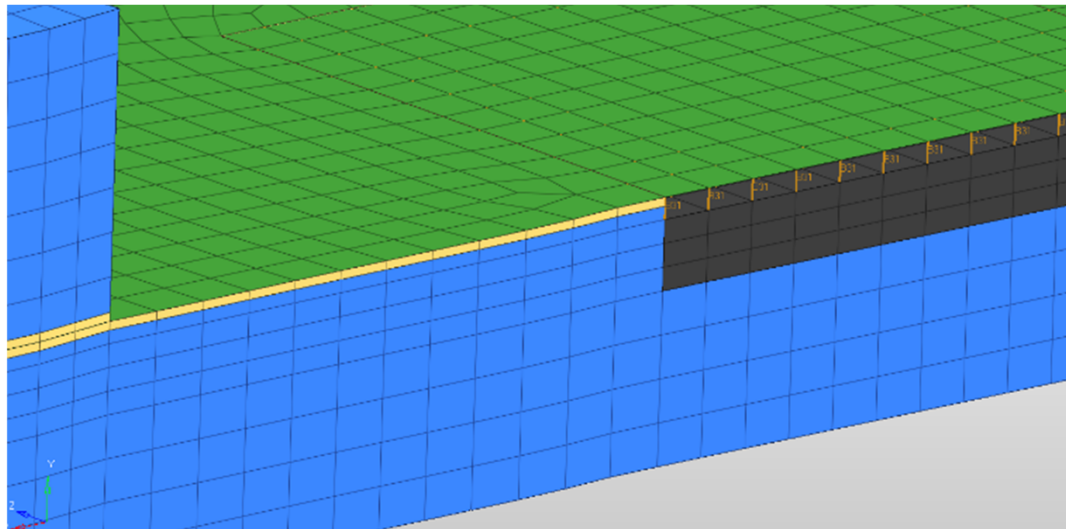
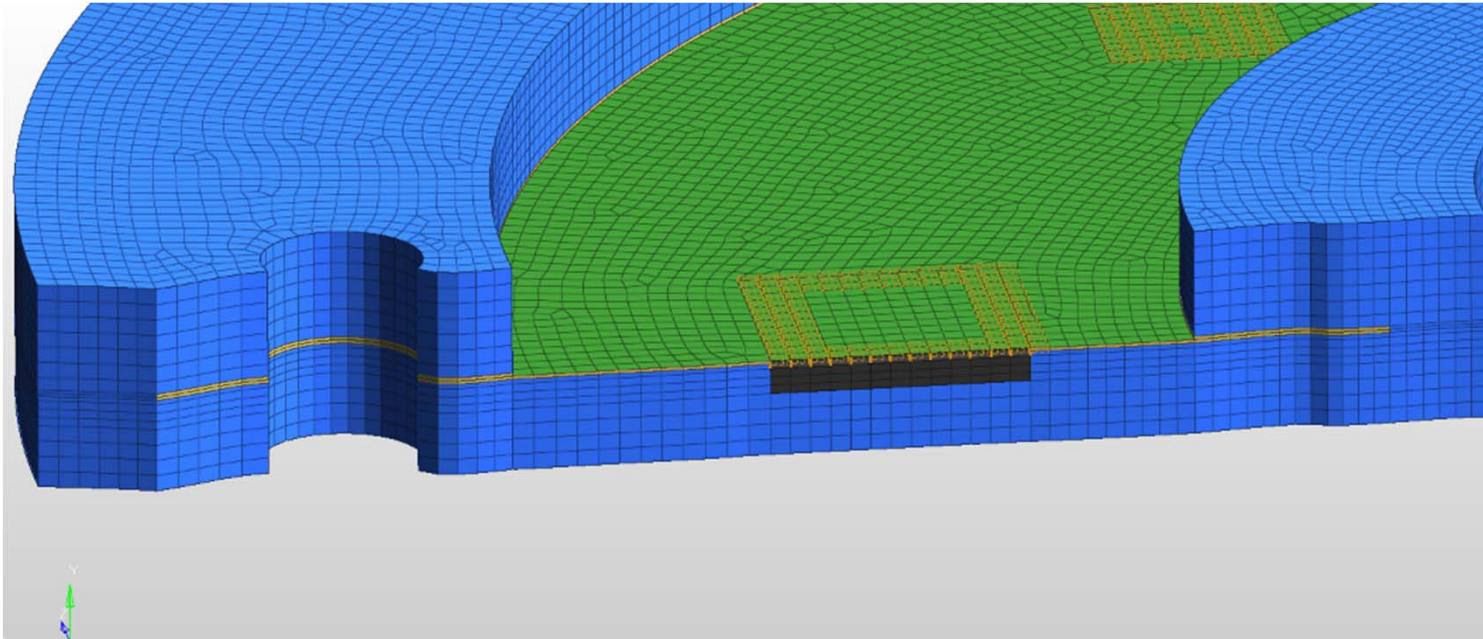

COH3D8 thickness: 0.1mm

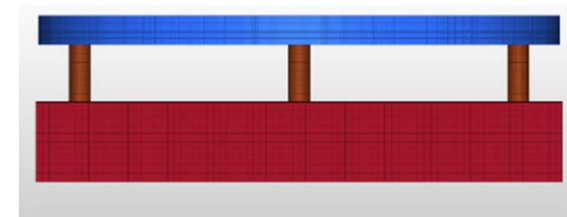

cave³

NSF Center for Advanced Vehicle and Extreme Environment Electronics



Modeling Cohesive Layer

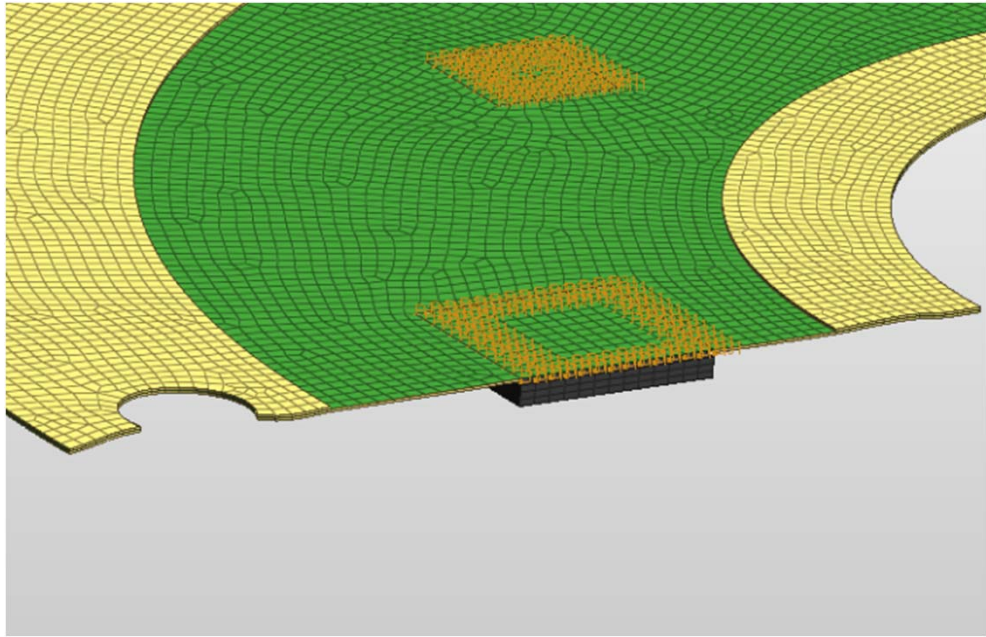
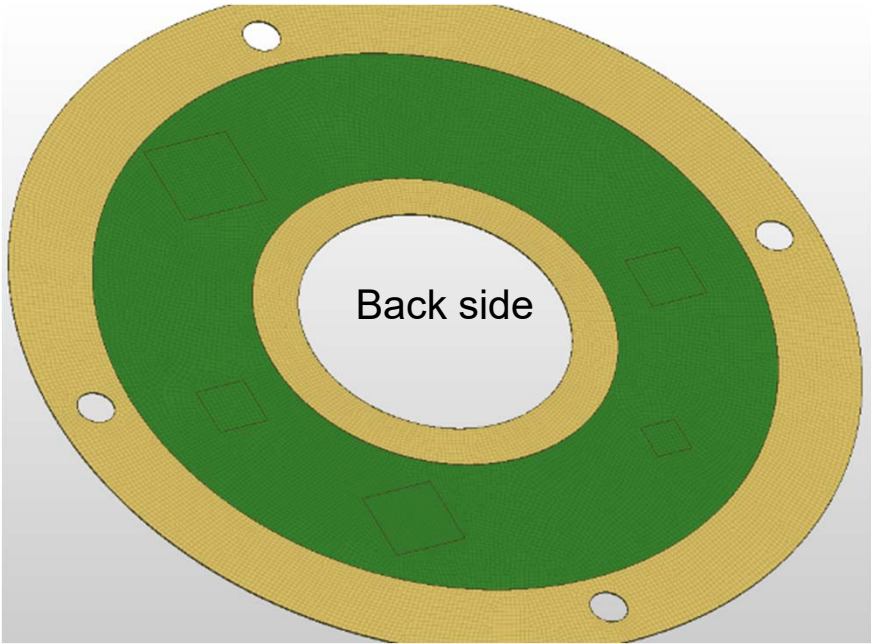
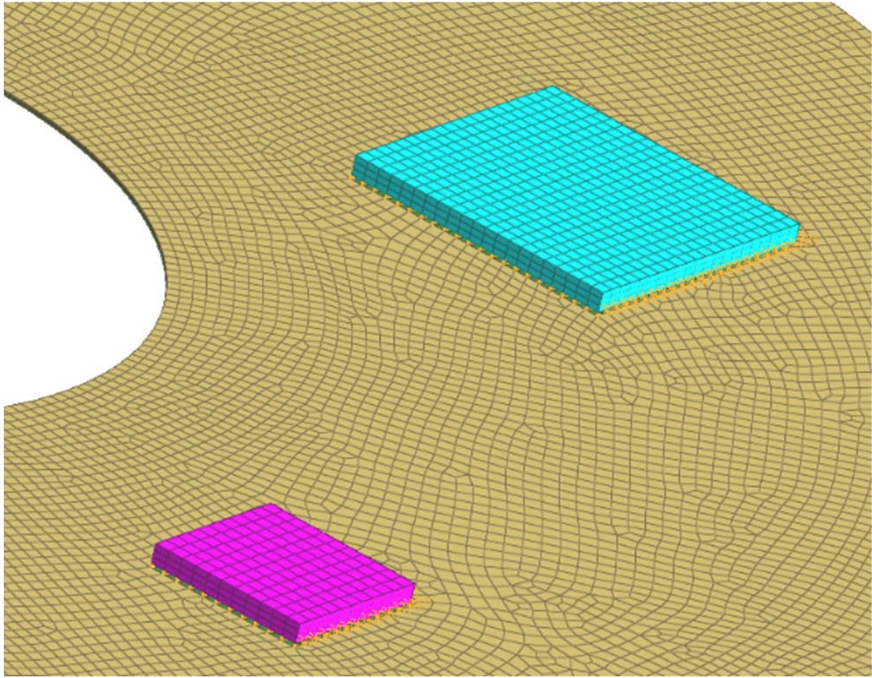
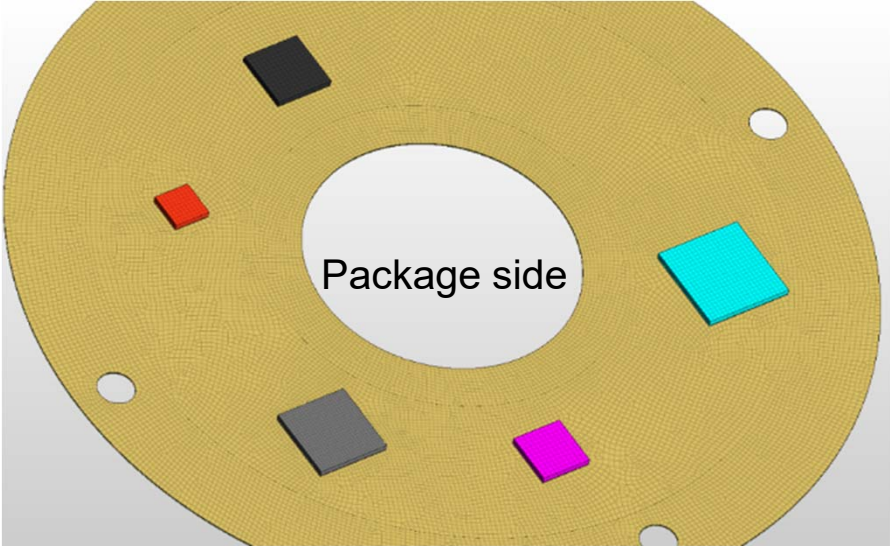

cave³

NSF Center for Advanced Vehicle and Extreme Environment Electronics



Simulation Status Output

Step: Step-1 Frame: 0
Total Time: 0.000000

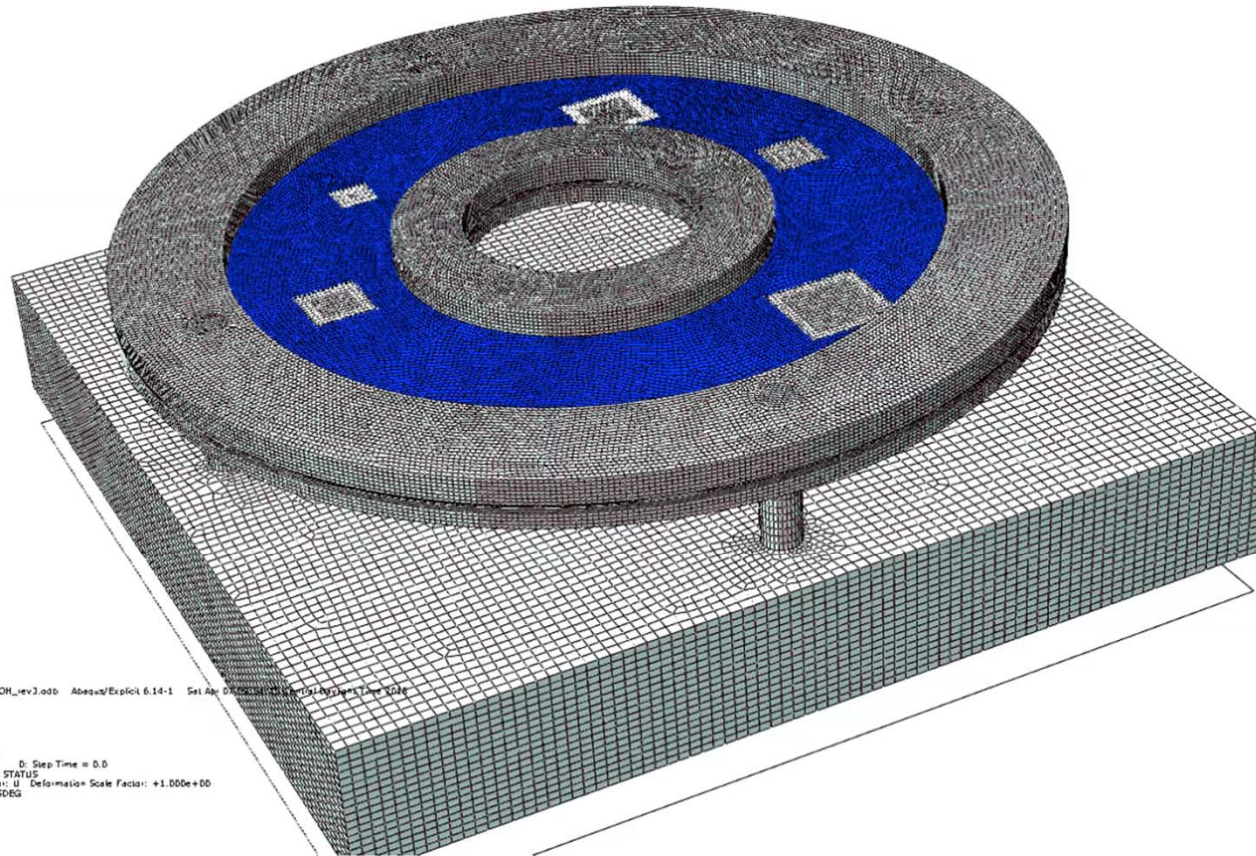
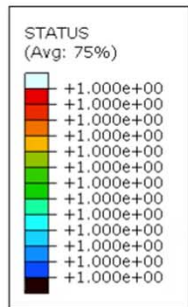

ODB: A12_CON_ev3.odb Abaqus/Explicit 6.14-1 Set Ab: D:\2023\A12\A12_Explicit_12_12_2023



Step: Step-1 D: Step Time = 0.0
Increment: 1 Primary Var: STATUS
Deformed Var: U Deformation Scale Factor: +1.000e+00
Status Var: SDEG

Out-of-plane displacement cohesive model

Peak Value: 4.94mm

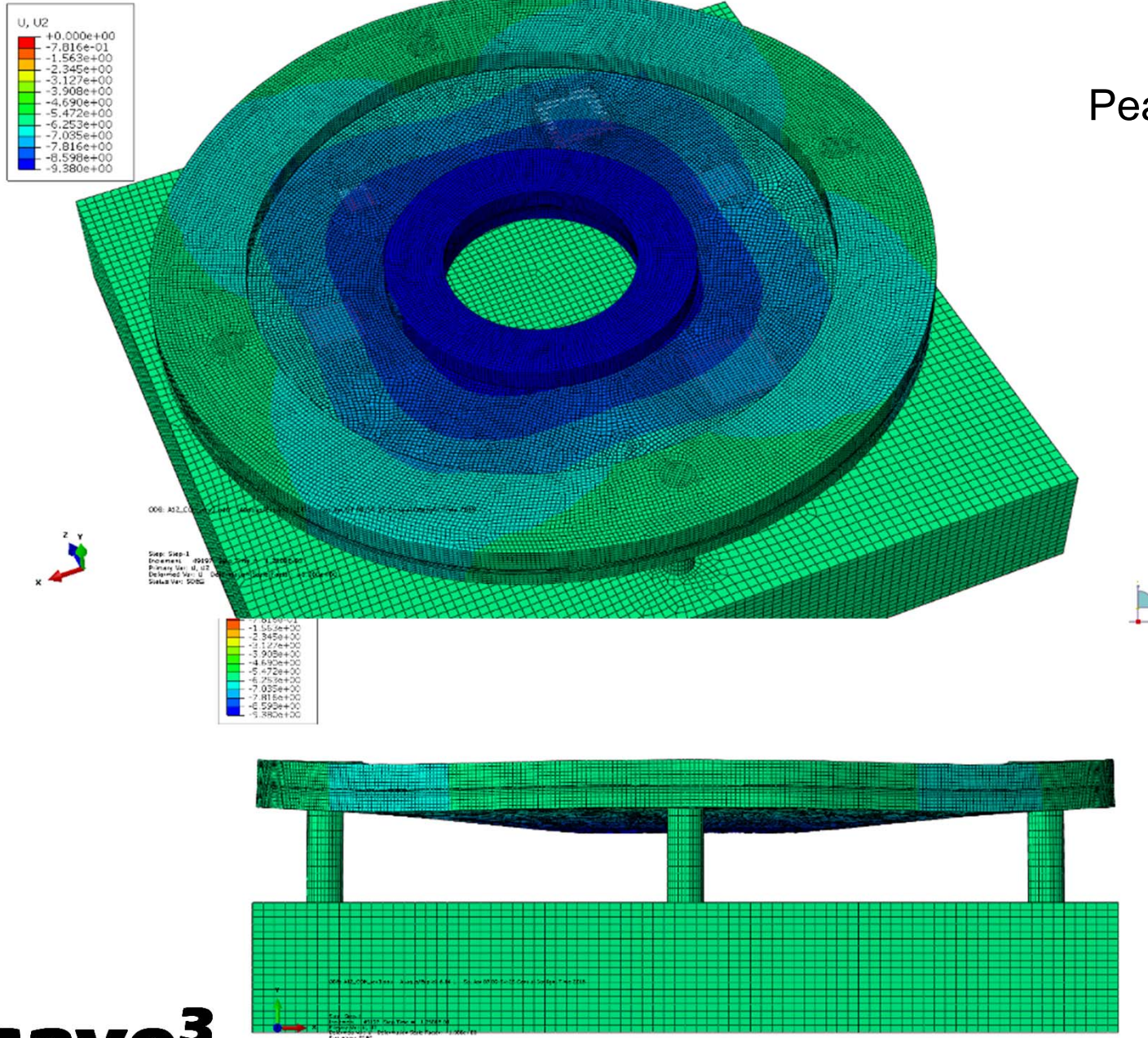

cave³

NSF Center for Advanced Vehicle and Extreme Environment Electronics



Out-of-plane displacement linear elastic model

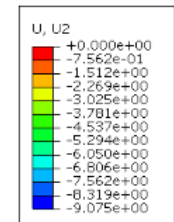

Peak Value: 4.52mm

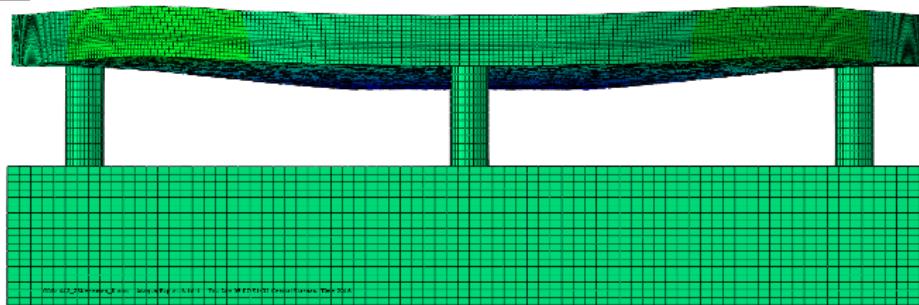
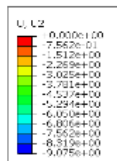
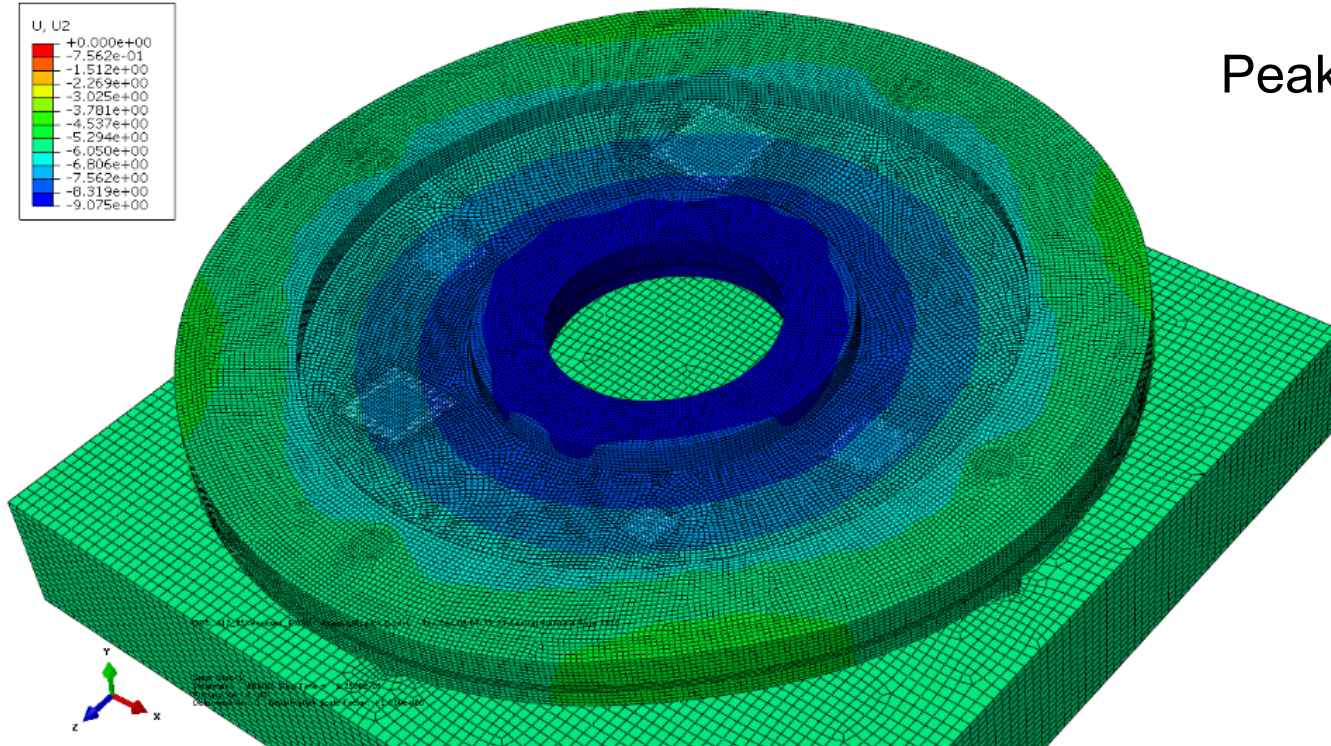

Linear Elastic vs CZM

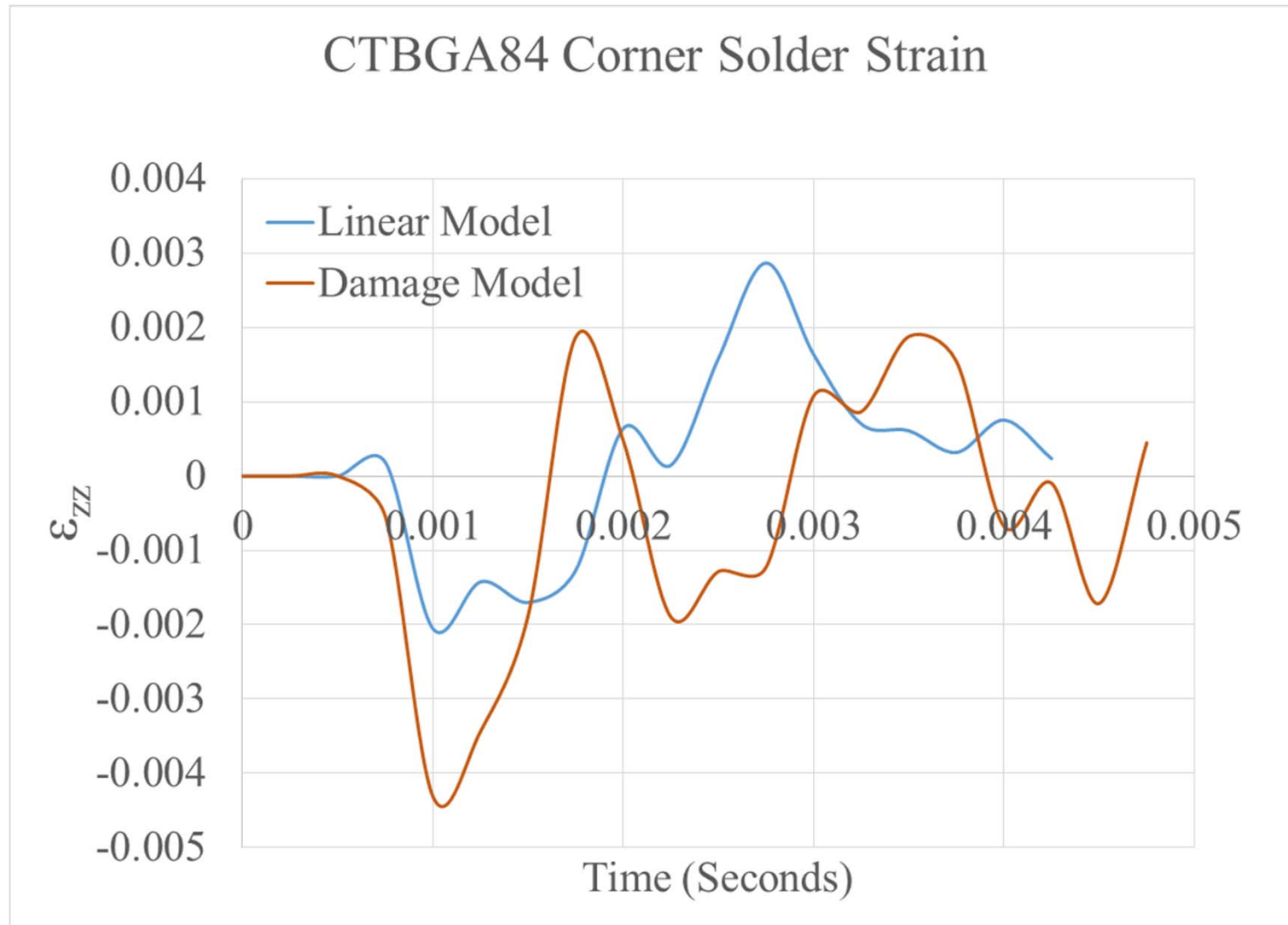

TV-1: 0.4mm, 0.5mm packages

TV1 with 0.4mm and 0.5mm polymer interconnects correlates high-g test data with already tested SAC305 interconnects of the same design

- Addition of 3640 MLC capacitors
- SMD and NSMD pads on front and back sides of PCB respectively
- 4 Layer PCB design

Package	Ball Pitch	Polymer Ball Dia	Topline ref no.
CVBGA97	0.4mm	250 μ m	NN2-SOL250-10C40SA
CVBGA360	0.4mm	250 μ m	NN2-SOL250-10C40SA
CTBGA84	0.5mm	310 μ m	NN2-SOL310-10C40SA
CTBGA132	0.5mm	310 μ m	NN2-SOL310-10C40SA
CTBGA228	0.5mm	310 μ m	NN2-SOL310-10C40SA

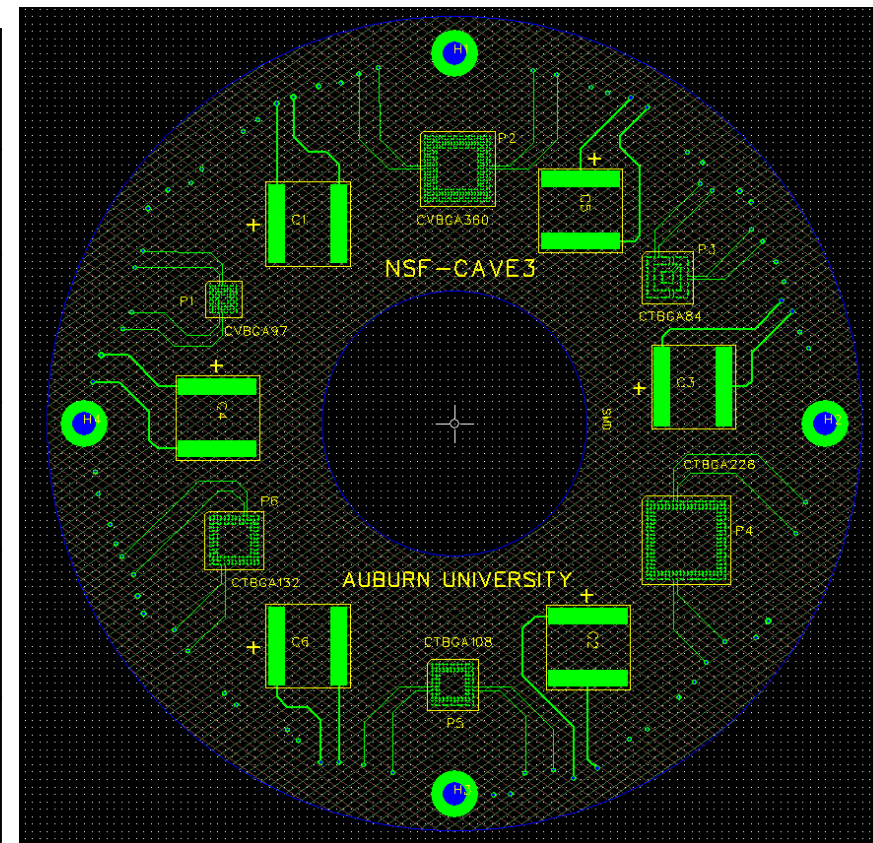

cave³

NSF Center for Advanced Vehicle and Extreme Environment Electronics



AUBURN
UNIVERSITY

TV1 - Fabricated

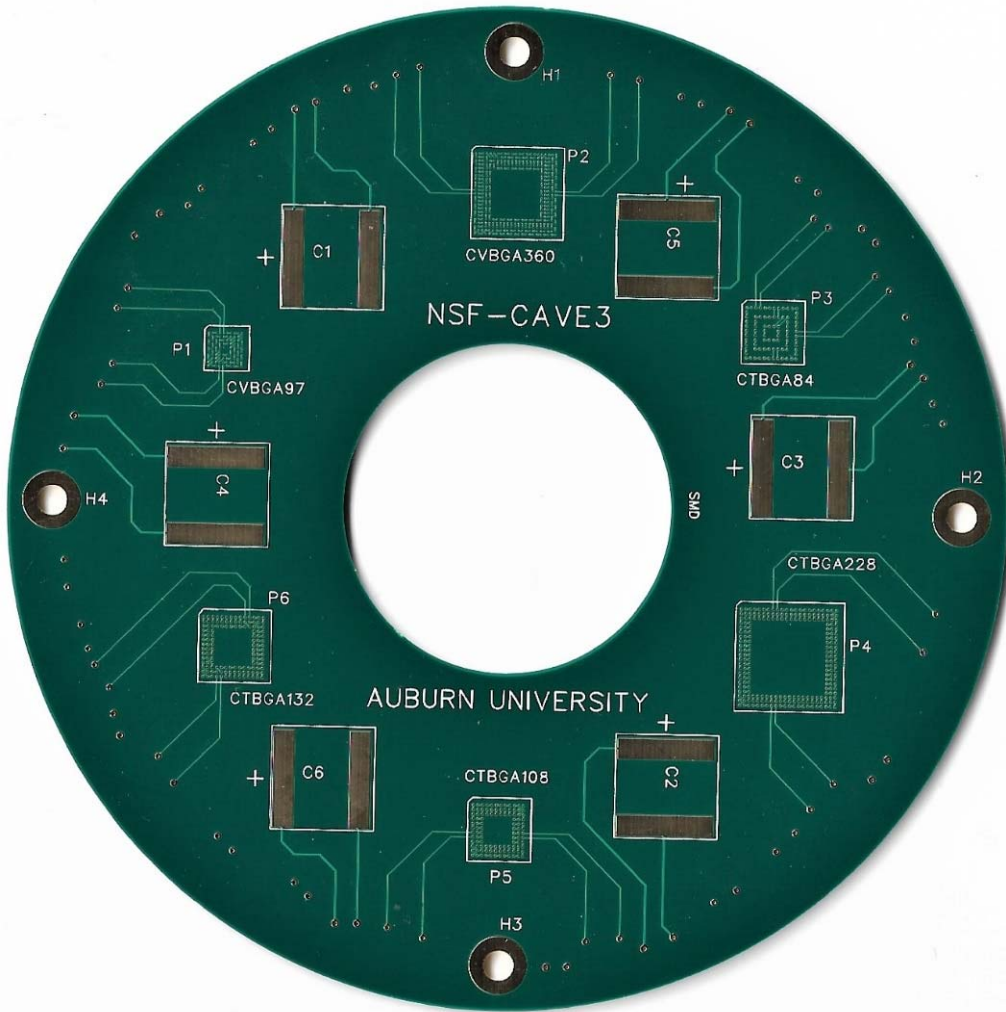

SMD Side

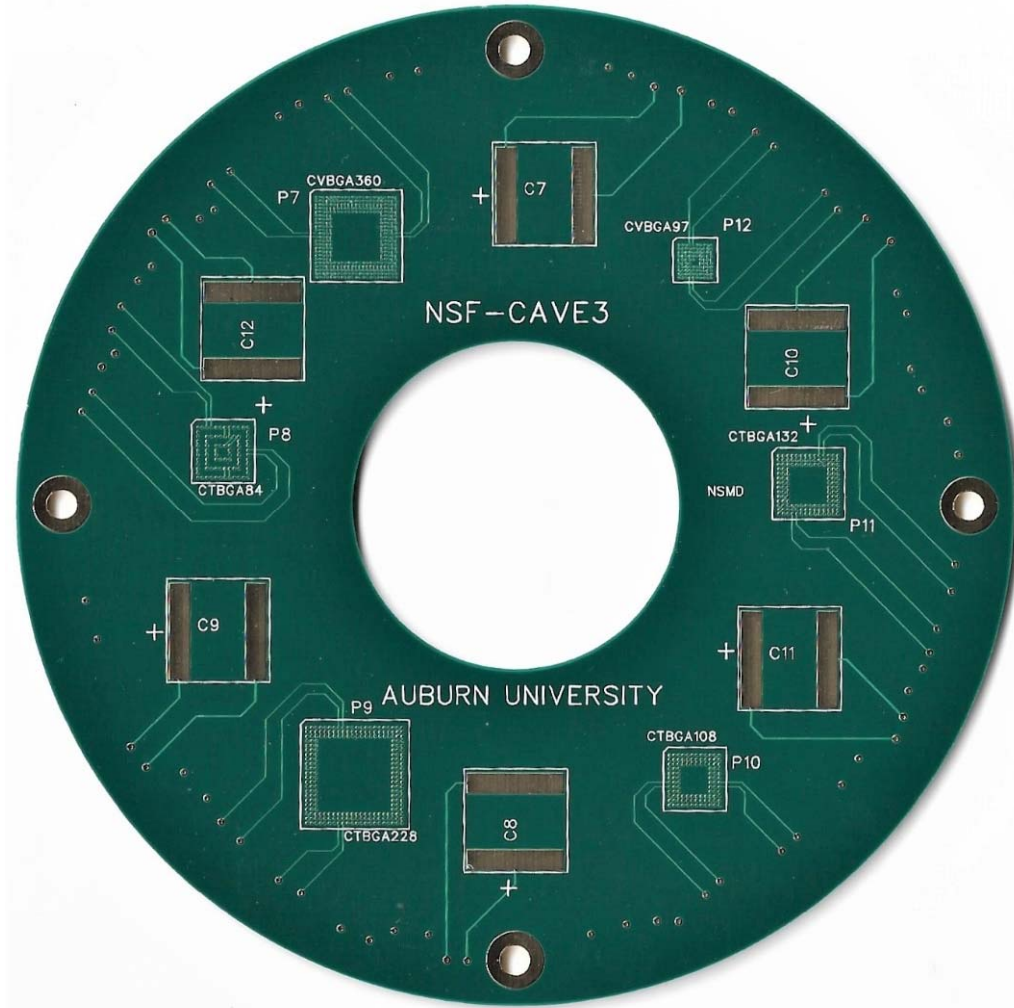

NSMD Side

cave³

NSF Center for Advanced Vehicle and Extreme Environment Electronics



AUBURN
UNIVERSITY

TV-1: Proposed Test Matrix

Number of boards to test for each condition						
PCB Side	10,000g			25,000g		
	0.1ms	0.2ms	0.3ms	0.05ms	0.1ms	0.2ms
NSMD	2	2	2	2	2	2
SMD	2	2	2	2	2	2

Note:

- Every board has one component each of CVBGA97, CVBGA360, CTBGA84, CTBGA132 and CTBGA228 per side.
- So, in total we need 24 polymer core assemblies for each component type.

New TV: 0.4mm, 0.5mm and 1mm packages

Design includes 0.4mm, 0.5mm and 1mm BGAs. 0.4mm and 0.5mm packages are at same location as previously tested boards.

- Addition of 3640 MLC capacitors
- SMD and NSMD pads on front and back sides of PCB respectively
- 4 Layer PCB design

Package	Ball Pitch	Polymer Ball Dia	Topline ref no.
CVBGA97	0.4mm	250 μ m	NN2-SOL250-10C40SA
CTBGA84	0.5mm	310 μ m	NN2-SOL310-10C40SA
CABGA196	1mm	670 μ m	NN2-SOL670-20C40SAH
CABGA256	1mm	670 μ m	NN2-SOL670-20C40SAH

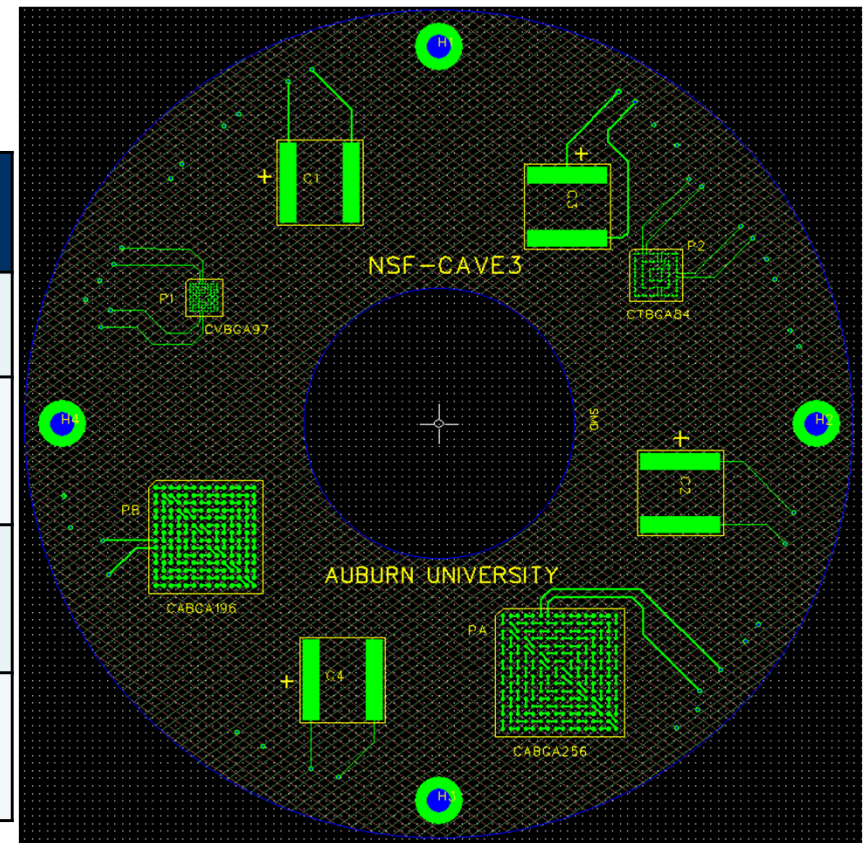

Front-SMD side

Proposed Test Matrix

Number of boards to test for each condition				
PCB Side	10,000g		25,000g	
	0.1ms	0.3ms	0.05ms	0.2ms
NSMD	2	2	2	2
SMD	2	2	2	2

Note:

- Every board has one component each of CVBGA97, CTBGA84, CABGA196 and CABGA256 per side.
- So, in total we need 16 polymer core assemblies for each component type.

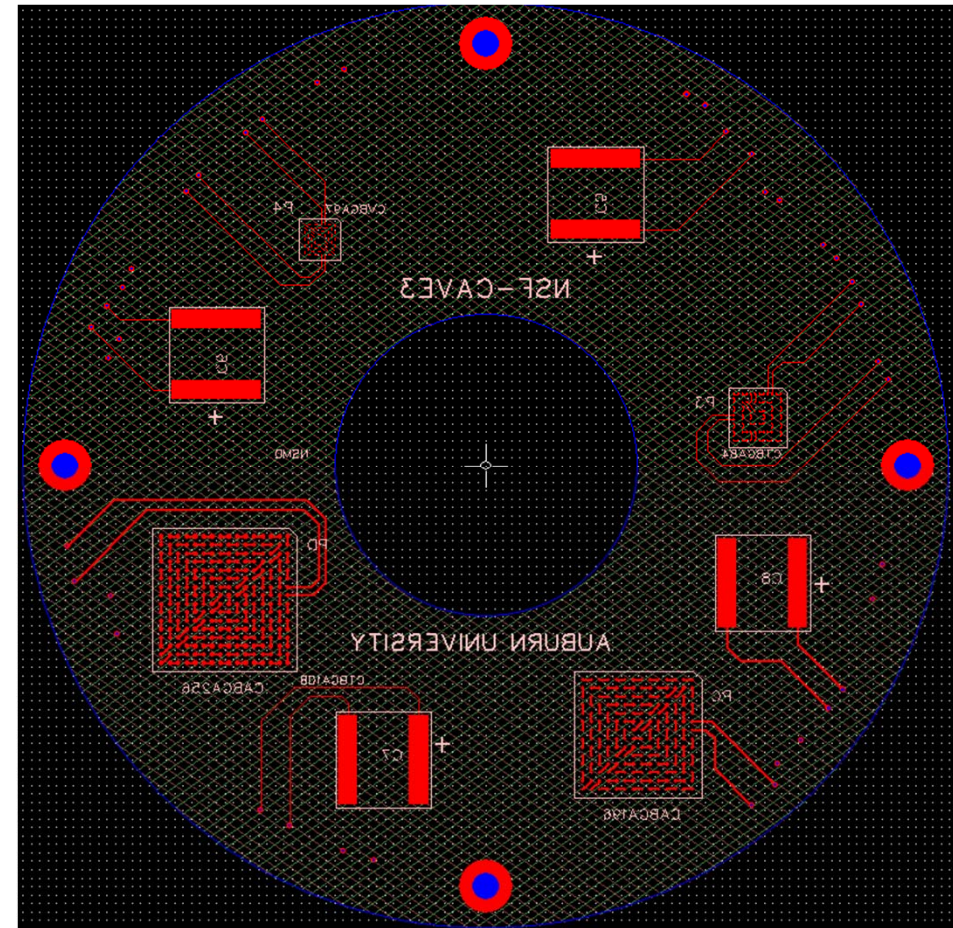

Back-NSMD side

cave³

NSF Center for Advanced Vehicle and Extreme Environment Electronics



Total package assemblies

Package	Ball Pitch	Polymer Ball Dia	Topline ref no.	No. of polymer balled assemblies needed
CVBGA97	0.4mm	250 μ m	NN2-SOL250-10C40SA	16
CTBGA84	0.5mm	310 μ m	NN2-SOL310-10C40SA	16
CABGA196	1mm	670 μ m	NN2-SOL670-20C40SAH	16
CABGA256	1mm	670 μ m	NN2-SOL670-20C40SAH	16

Summary & Conclusions

- Interfacial toughness of potting compounds-PCB interface has been measured
- Effect of cure condition on K_{1C} is quantified
- In general a weak interface will promote the delamination along the interface while a strong one will not delaminate at all.
- Higher compliance in the cured epoxy resin allows for higher energy storage without delamination.
- Peak fracture toughness values were observed when cured just before the T_g for all the epoxy materials.

Reliability of a Fuze Assembly Using Micro-CT data based FE and Digital Volume Correlation

N. Kothari, P. Lall

- ❑ Fuze assemblies are often subjected to harsh environments like high temperature, high g and low g shocks and vibration, from the time of manufacturing, storage and service life.
- ❑ Monitoring the internal damage sustained and the degradation in the materials is challenging but required to study reliability.
- ❑ Densely packed electrical assemblies like fuze, contain large number of components, potted in protective adhesives.
- ❑ The number of components, material types, irregular geometry of the components and the geometric details of the assembly makes conventional CAD modeling, meshing and Finite Element(FE) modeling of these large assemblies extremely time consuming
- ❑ In this work, X-ray MicroCT based Digital Volume Correlation and X-ray MicroCT based finite element models to experimentally measure deformations have been investigated.

Motivation



- Missiles in Army inventory must withstand long periods of storage and be "launch ready".
- Along side the extreme temperature soaks and aging, they also endure the abuse of frequent transportation and handling.



- Need for better Cost Effective Techniques to reassess the shelf life to make the missiles more cost effective.
- Need for non-destructive method that can actively track the damage progression in terms of deformations and strains over the entire domain.
- Lack of literature on the studies involving damage quantification on fuze assemblies when subjected to harsh environments

cave³

NSF Center for Advanced Vehicle and Extreme Environment Electronics



State of Art

Contribution Area	Contribution	Authors
Reliability Studies	RUL Prediction of fine pitch BGA in Missile electronics	Lall 2016
	Component Reliability in Fuze electronics	Li 2016, Ya 2010
	System Reliability in Fuze Electronics	Zhi-Feng 2010
	Failure Threshold Statistics of Fuze	Hager 2016
Simulations on internal functioning	Finite Element modeling approach	Lall 2016,Lall2017, Li 2016
	Virtual Test Platforms for Fuze	Hongshung 2010
CT Data based FE modeling	Human Body Models	Taddei 2006,Yi 2014,Rahman 2009,Diemente 1991
	Electronics Packaging	Lall 2016,Lall 2016, Lall 2017
Digital Volume Correlation	Human Body	Tozzi 2016, Palanca 2016 and Gilliard 2014
	Electronics Packaging	Lall 2016,Lall 2016, Lall 2017

Hypothesis and Objective

Hypothesis

- Electrical sub-assemblies inside of a densely packed Fuze assembly, can be monitored for deformations and strains in a non-destructive way over it's service life.
- Deformations and strains, can be recorded over the entire domain of the fuze assembly as a function of time.

Objectives

- Use the micro-CT data to compute deformation, strain and nature of deformation upon external load experimentally and using FE modeling
- Come up with a technique to remove the human error involved in scanning the fuze at different time intervals.

Test Vehicle and Setup

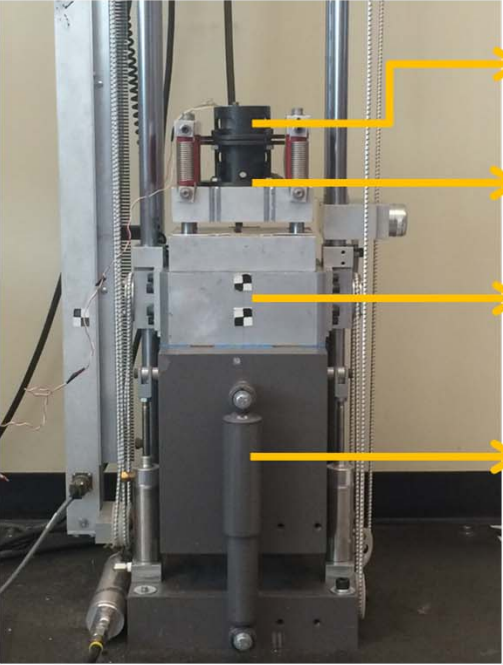

- Fuze
- Fixture
- DMSA
- Drop Tower

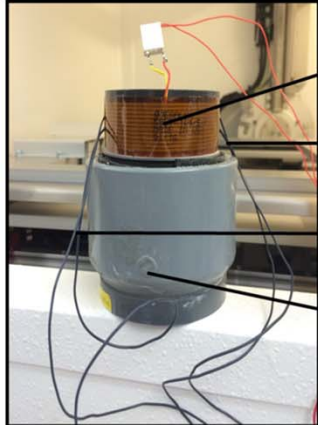
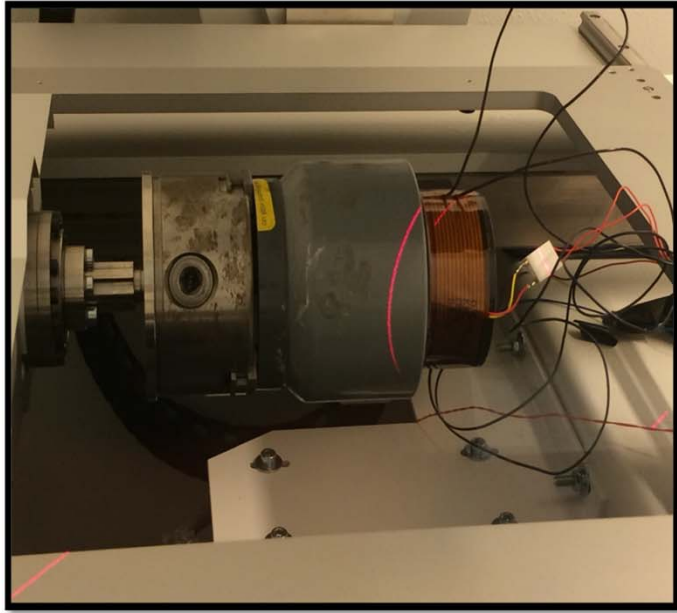
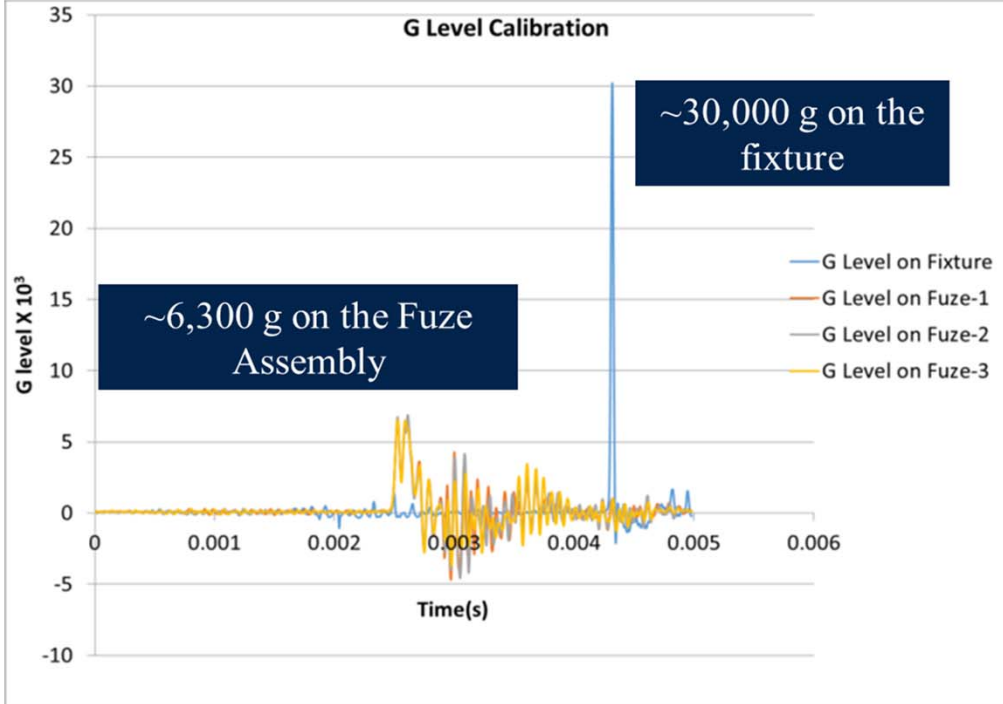

- Thermocouple
- AC Heater 1
- AC Heater 2
- Fuze Fixture

Thermal Load Profile

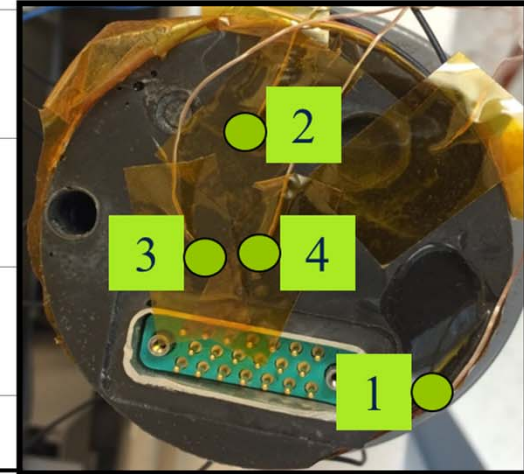
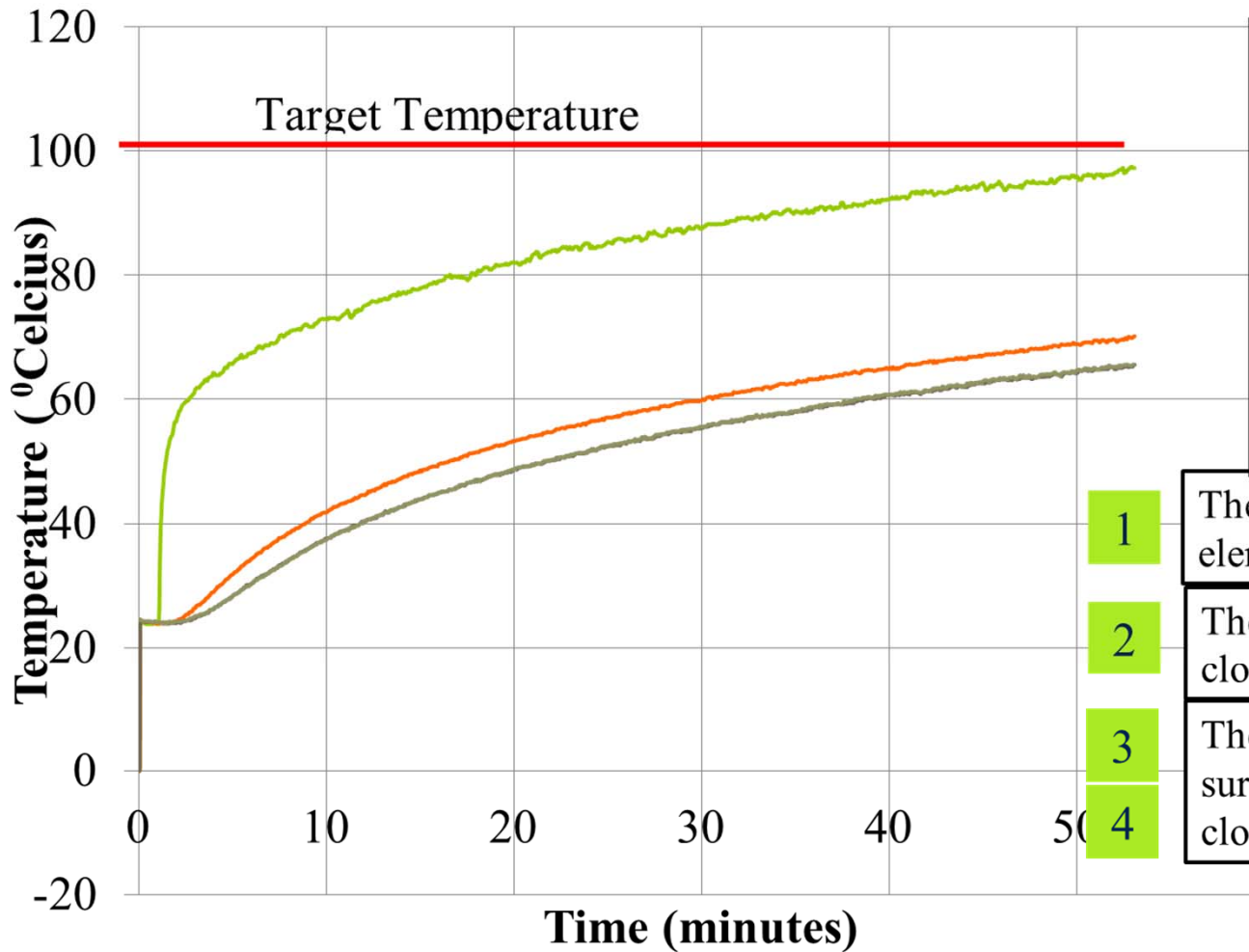

- 1 Thermocouple inserted between the element heater and fuze surface
- 2 Thermocouple attached on the top surface, closest to the heating surface
- 3 Thermocouples attached on the top surface, farthest to the heating surface, close to each other
- 4 Thermocouples attached on the top surface, farthest to the heating surface, close to each other

Thermal Load: 100°C

Digital Volume Correlation

Voltage: 130 kV

Current: 40
microAmps

Type of scan: 1024
X 1024 X 1024

Resolution : 0.0628
mm

Step Size: 1 voxel

$$C = 1 - \frac{\sum_{i=1}^L \sum_{j=1}^M \sum_{k=1}^N (V_{ijk} - \bar{V})(V'_{ijk} - \bar{V}')}{\sqrt{\sum_{i=1}^L \sum_{j=1}^M \sum_{k=1}^N (V_{ijk} - \bar{V})^2 (V'_{ijk} - \bar{V}')^2}}$$

V_{ijk} : contains the grayscale values,
 \bar{V} : mean of the grayscale values in
the subset,

C : Correlation coefficient for the
quantity being minimized for
calculation of the deformation
accrued in the structure

Digital Volume Correlation

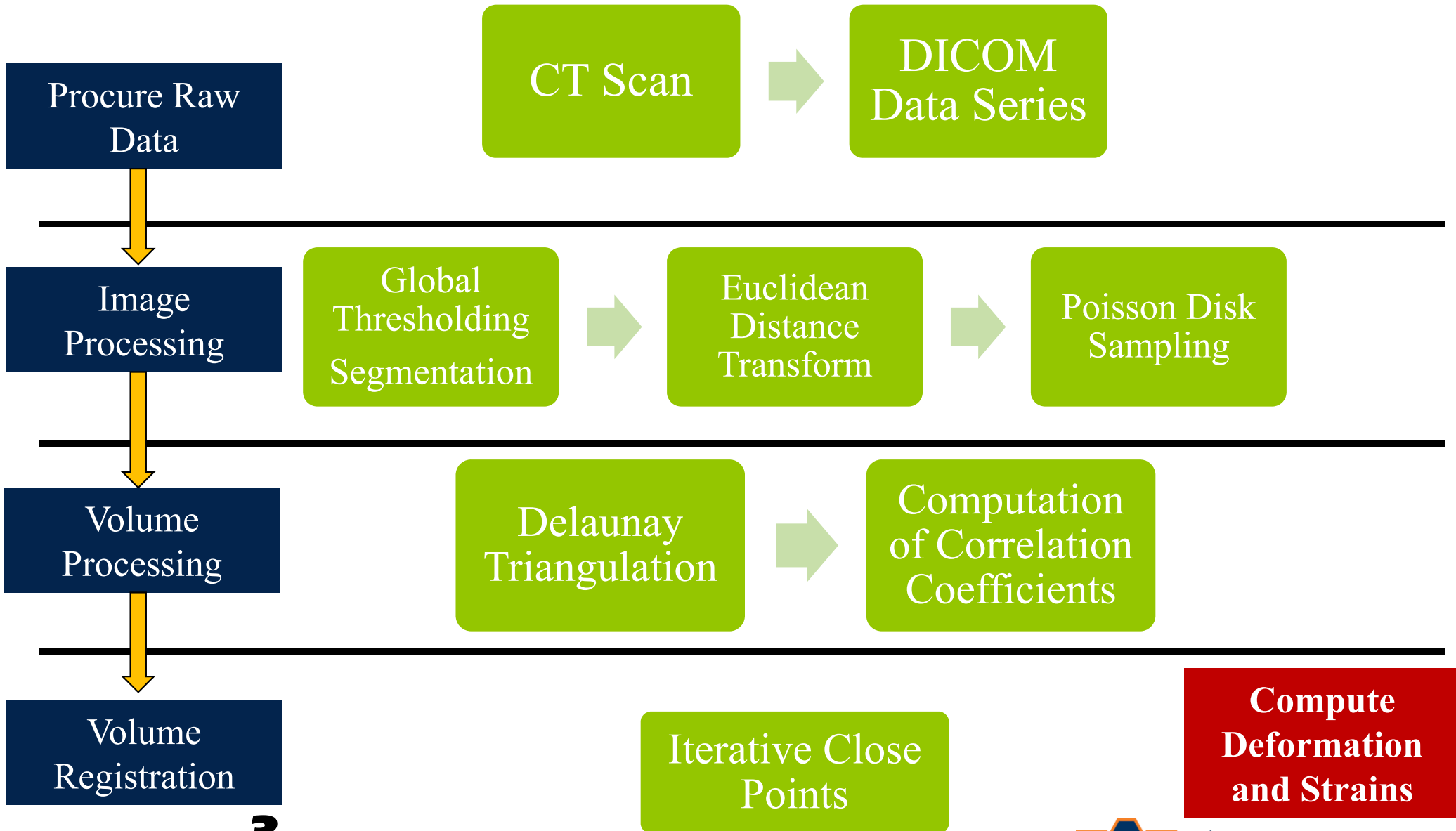

cave³

NSF Center for Advanced Vehicle and Extreme Environment Electronics



AUBURN
UNIVERSITY

Micro-CT Scan DICOM Data

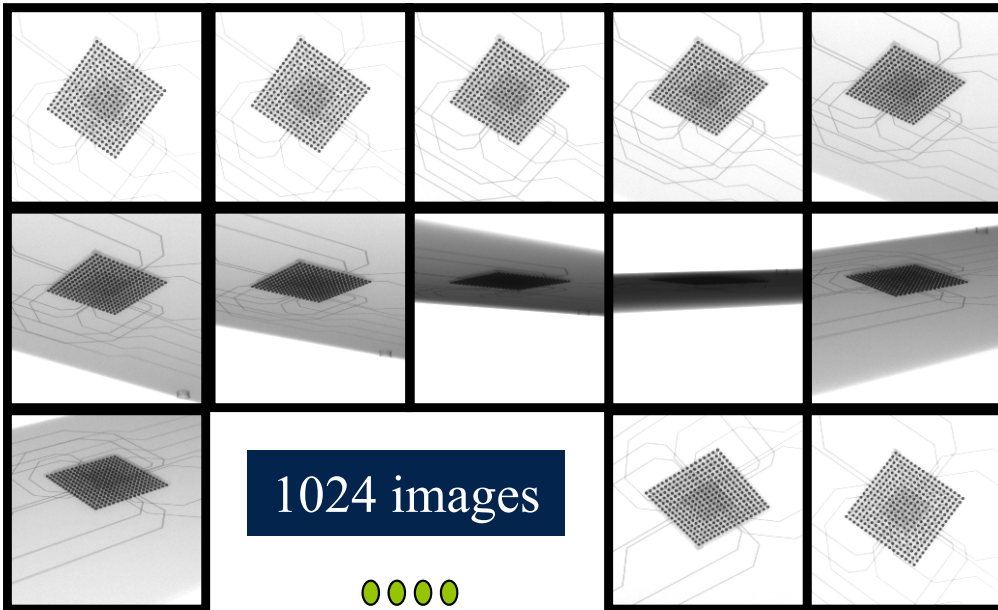

04	49624	41970	32556	26995	24149	24049	24189	24295	24915	25209	24402	24649	24382	24962	25835	27735	31849	37944	47664	57778
18	52177	45803	35469	28395	25349	24502	24028	24149	24415	24622	24162	24142	24429	25582	26629	29009	33316	41483	50671	59958
71	55398	50524	39116	31322	27549	25935	25309	24442	24315	24482	24589	25029	24842	25755	27829	31136	36611	44577	55184	62725
65	60638	57138	46997	35669	31322	28249	27655	26702	25522	25775	25682	25469	26089	27409	30369	34671	42697	51751	60578	65112
18	63098	61785	54671	45557	38700	34856	32216	29896	29069	28109	28095	27695	28169	30156	34721	41436	51471	58884	63778	65535
38	64592	63465	60571	55684	49384	44657	38743	37089	35776	34416	33363	32649	32469	31043	41076	50891	58558	63085	65032	65535
45	65218	64665	63545	60345	57784	54397	50984	47137	44883	43483	42017	40490	41476	44310	51437	58818	63211	64712	65312	65535
92	64698	64985	64432	63311	61918	61071	59611	57504	55751	53611	52291	53217	54951	56778	60038	62858	65535	65205	65535	65535
31	62805	64325	64538	64352	64498	64492	63418	63265	62158	60871	59731	60758	62785	63398	64165	65318	65535	65535	65535	65535

65,536 intensity values

16 bit grayscale images

Global Threshold Segmentation

- As per this technique , the voxels are partitioned depending on their intensity value (radio density in this case)
- As per the input Threshold value T:
- $$g(x, y) = \begin{cases} 1, & \text{if } f(x, y) > T \\ 0, & \text{if } f(x, y) \leq T \end{cases}$$
- The erroneous data is known to be minimum only if :
 - Histogram is bimodal

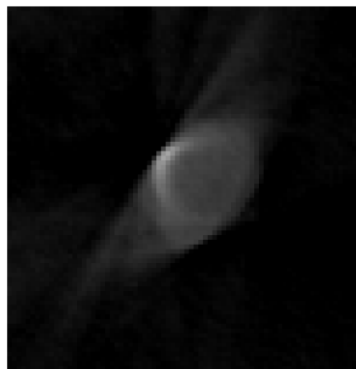

Original DICOM
image

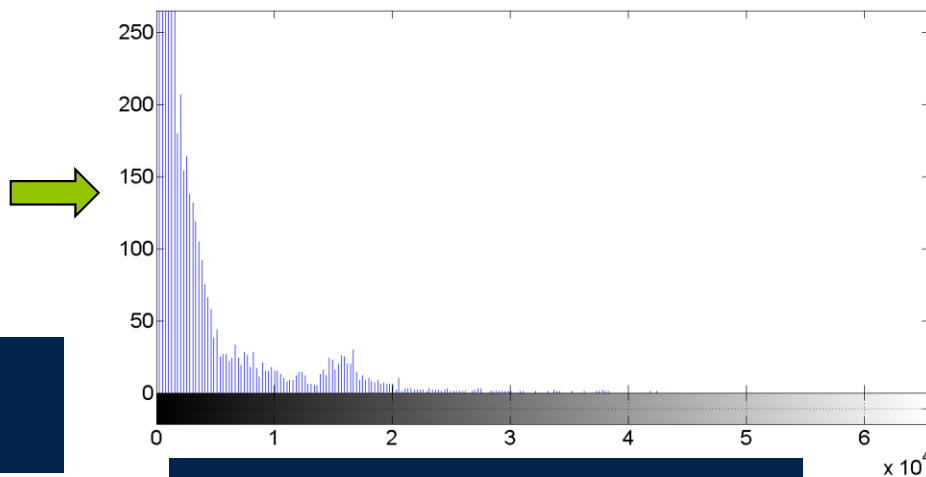

Bimodal Histogram



Binarized Image for Image
Segmentation

cave³

NSF Center for Advanced Vehicle and Extreme Environment Electronics



AUBURN
UNIVERSITY

Euclidean Distance Transform

$$I(x, y) \in \{Obj, bkgrd\}$$

$$I_d(x, y) \in \begin{cases} 0 & I(x, y) \in \{bkgrd\} \\ \min(\| (x - x_0), (y - y_0) \| \mid \forall I(x_0, y_0) \in \{obj\}) & I(x, y) \in \{obj\} \end{cases}$$

$$\|x, y\| = \sqrt{x^2 + y^2}$$

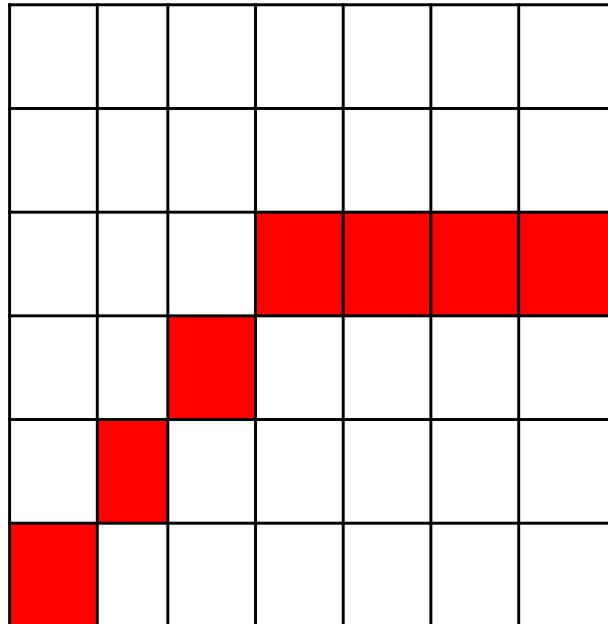
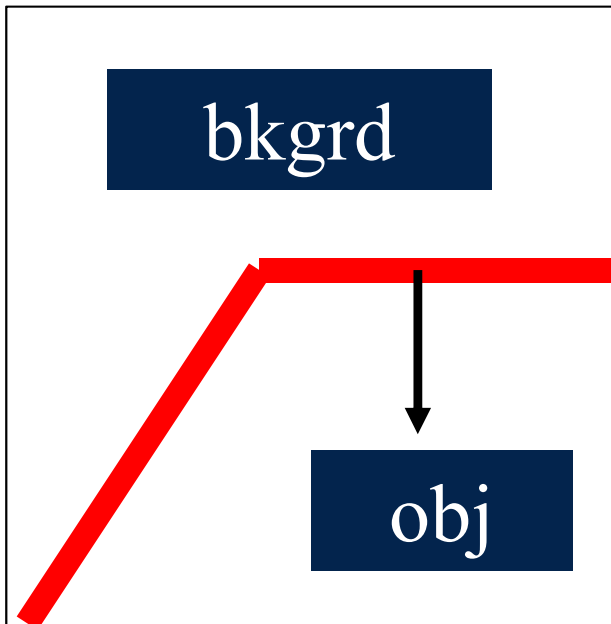

5	4	3	2	2	2	2
4	3	2	1	1	1	1
3	2	1	0	0	0	0
2	1	0	1	1	1	1
1	0	1	2	2	2	2
0	1	2	3	3	3	3

Poisson Disk Sampling

Poisson distribution of samples

$$P(x, \mu) = \frac{(e^{-\mu})(\mu^x)}{x!}$$

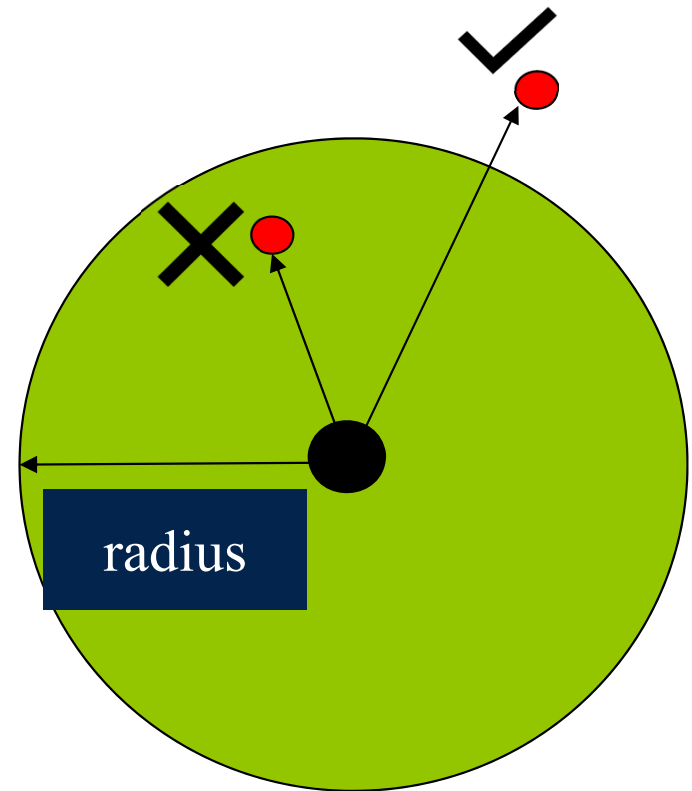
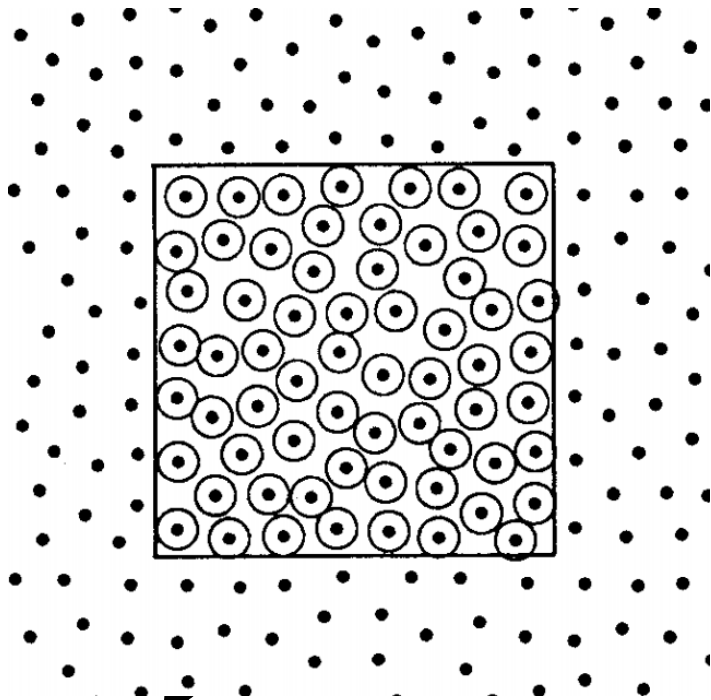

Potential samples are generated iteratively and checked for if they meet the acceptance criteria for acceptance or rejection

Iterative Close Points

Let P be a matrix whose i -th **column** is vector $p_i - c_D$

Let Q be a matrix whose i -th **column** is vector $q_i - c_R$

Forming the cross-covariance matrix M
 $M = P \times Q^T$

Translating and rotating the source to find new position

$$p'_i = c_R + R \cdot (p_i - c_D)$$

p'_i is the target position of point p_i

Now the rotation matrix R is found as a matrix that maximizes the trace

$$\text{Tr}[R \cdot M]$$

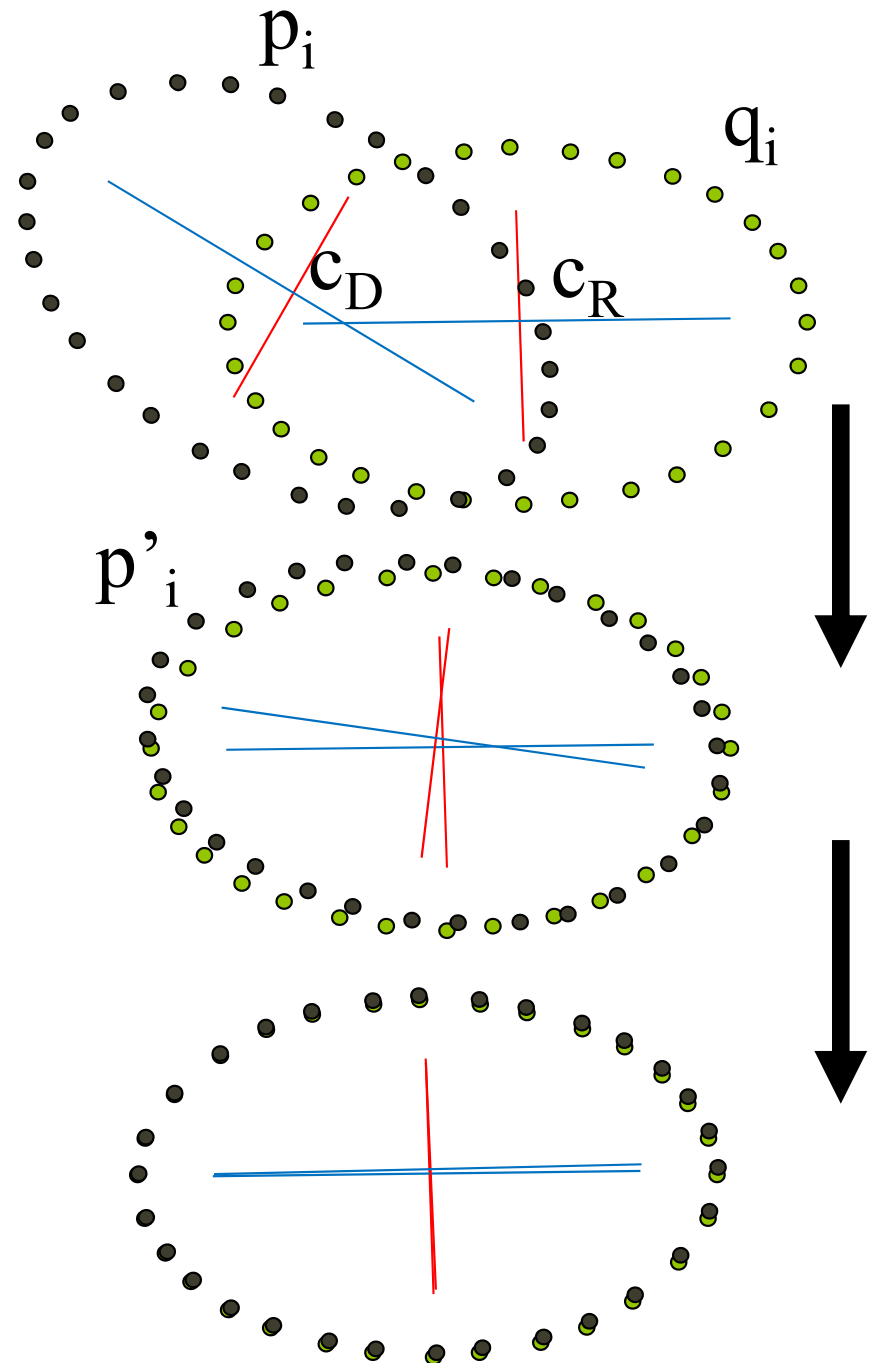

Digital Volume Correlation

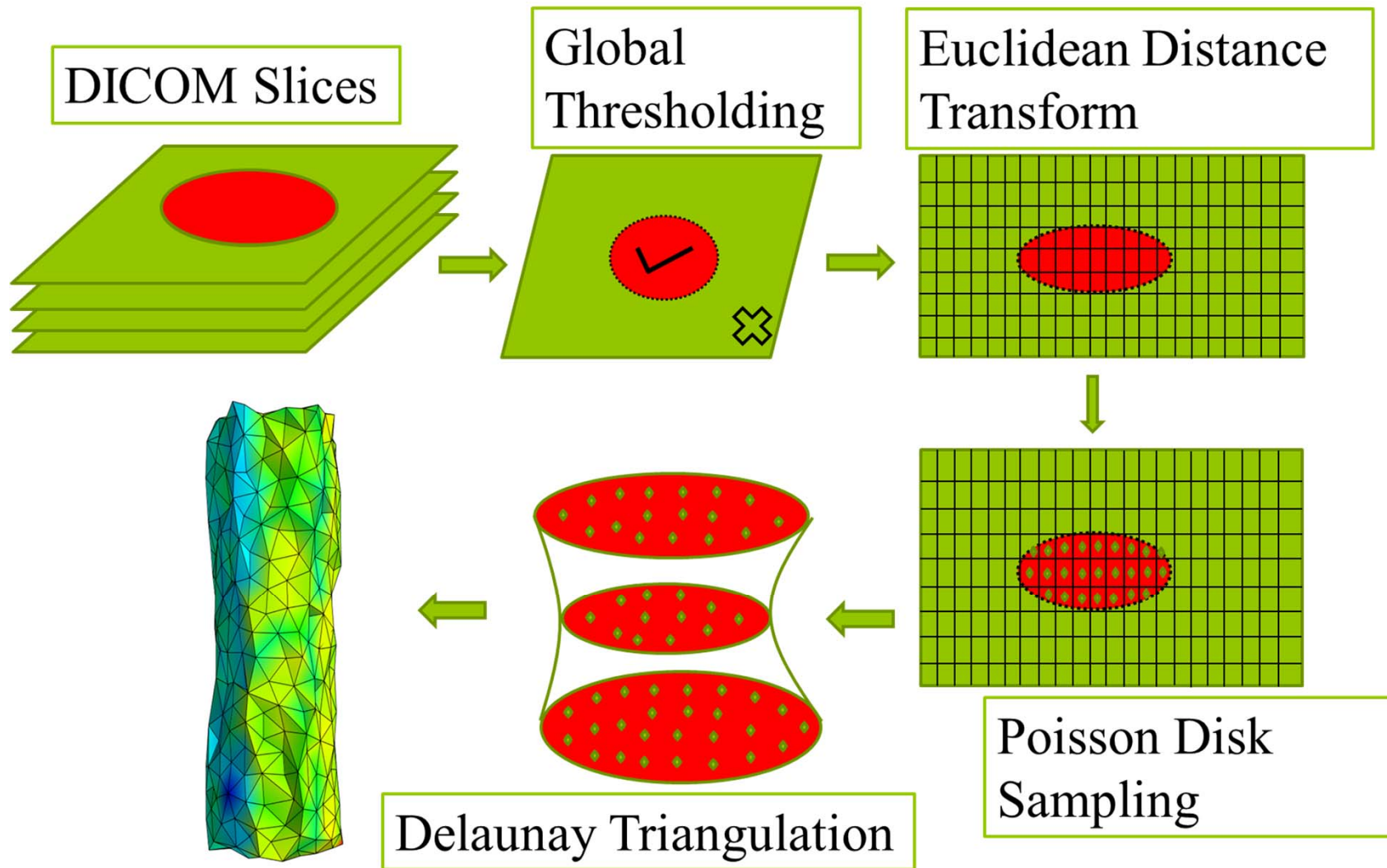

MicroCT Data to FE Mesh Conversion

Acquire DICOM Data

Gaussian Image Blurring

Otsu Image
Segmentation/Global
Threshold Segmentation

Image Clustering:
Marching Cubes

Geometry Repair: Weight
minimization triangulation

Poisson's surface
recostruction

Laplacian Mesh Smoothing

Delaunay Triangulation



cave³

NSF Center for Advanced Vehicle and Extreme Environment Electronics



AUBURN
UNIVERSITY

Material Properties

EDX Analysis

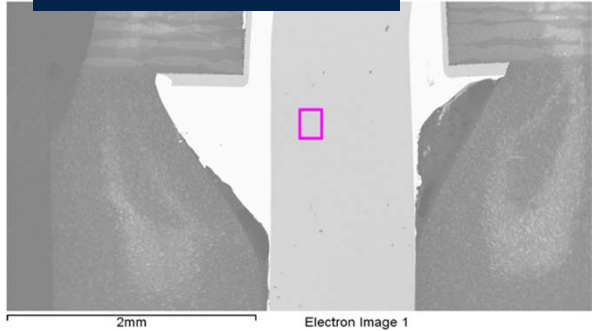

Element	Weight%	Atomic%
C K	2.99	15.69
Co K	-0.03	-0.04
Ni K	0.56	0.60
Cu K	77.91	77.20
Hf L	18.57	6.55
Totals	100.00	

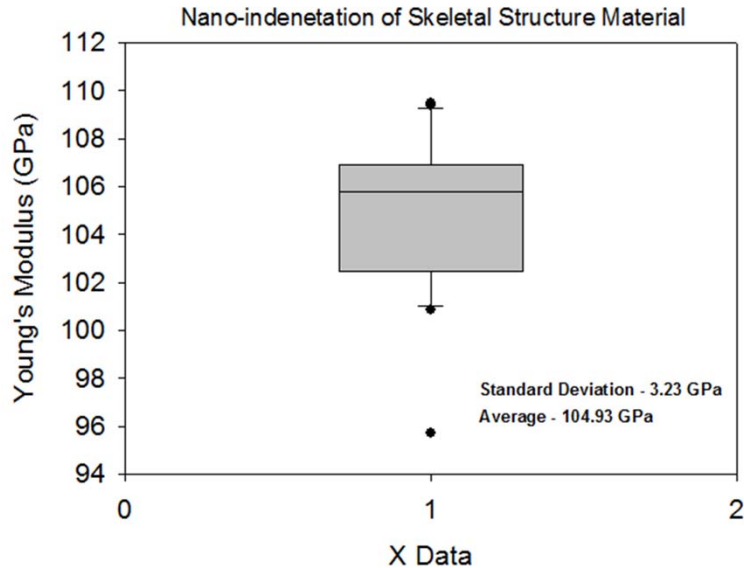
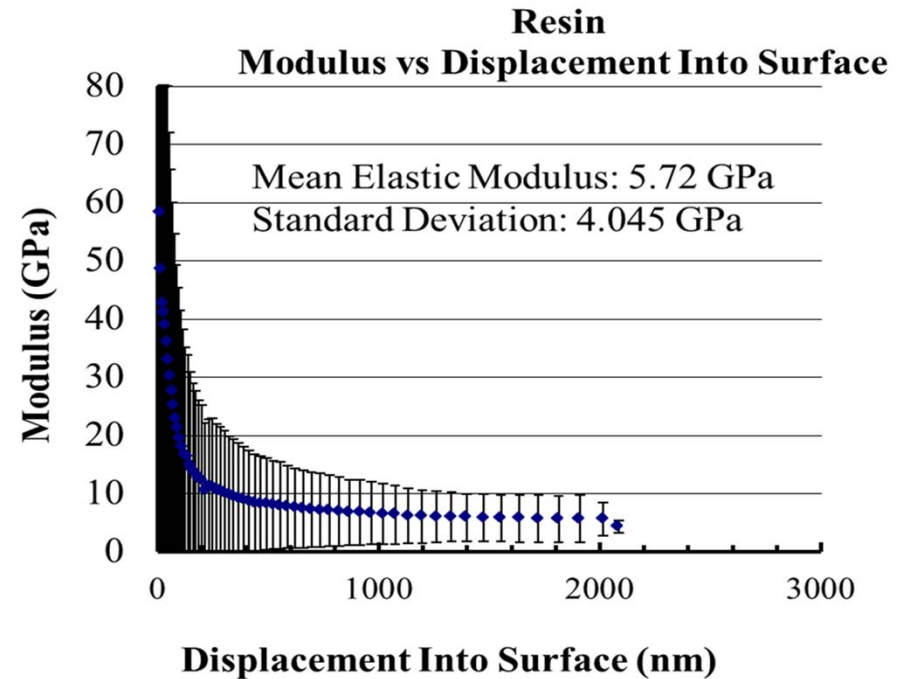

Material	Elastic Modulus (GPa)
Skeletal Structure Material	104.93
Potting Resin	5.72

MicroCT Data to FE Mesh Conversion

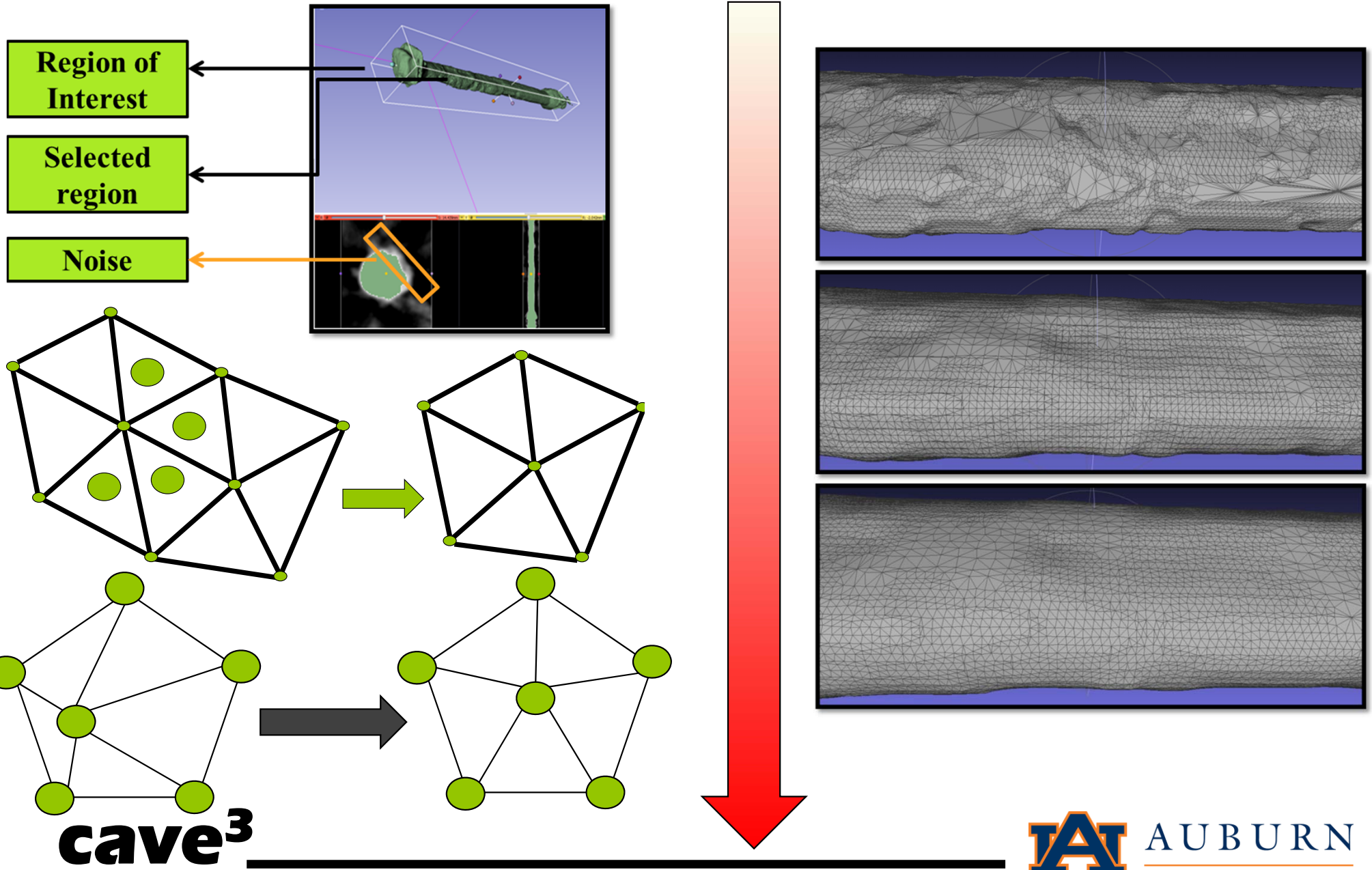

cave³

NSF Center for Advanced Vehicle and Extreme Environment Electronics

Nature of Displacement upon Thermal Load from overlapping of CT Scans

Reference Scan

Deformed Scan(Thermal Load)

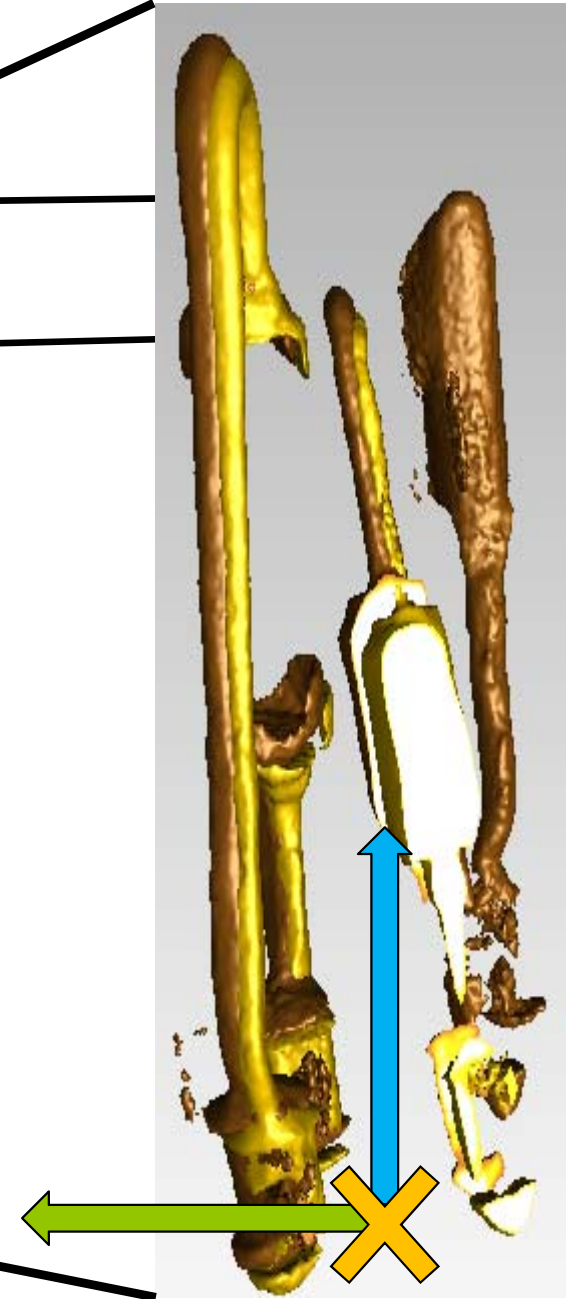
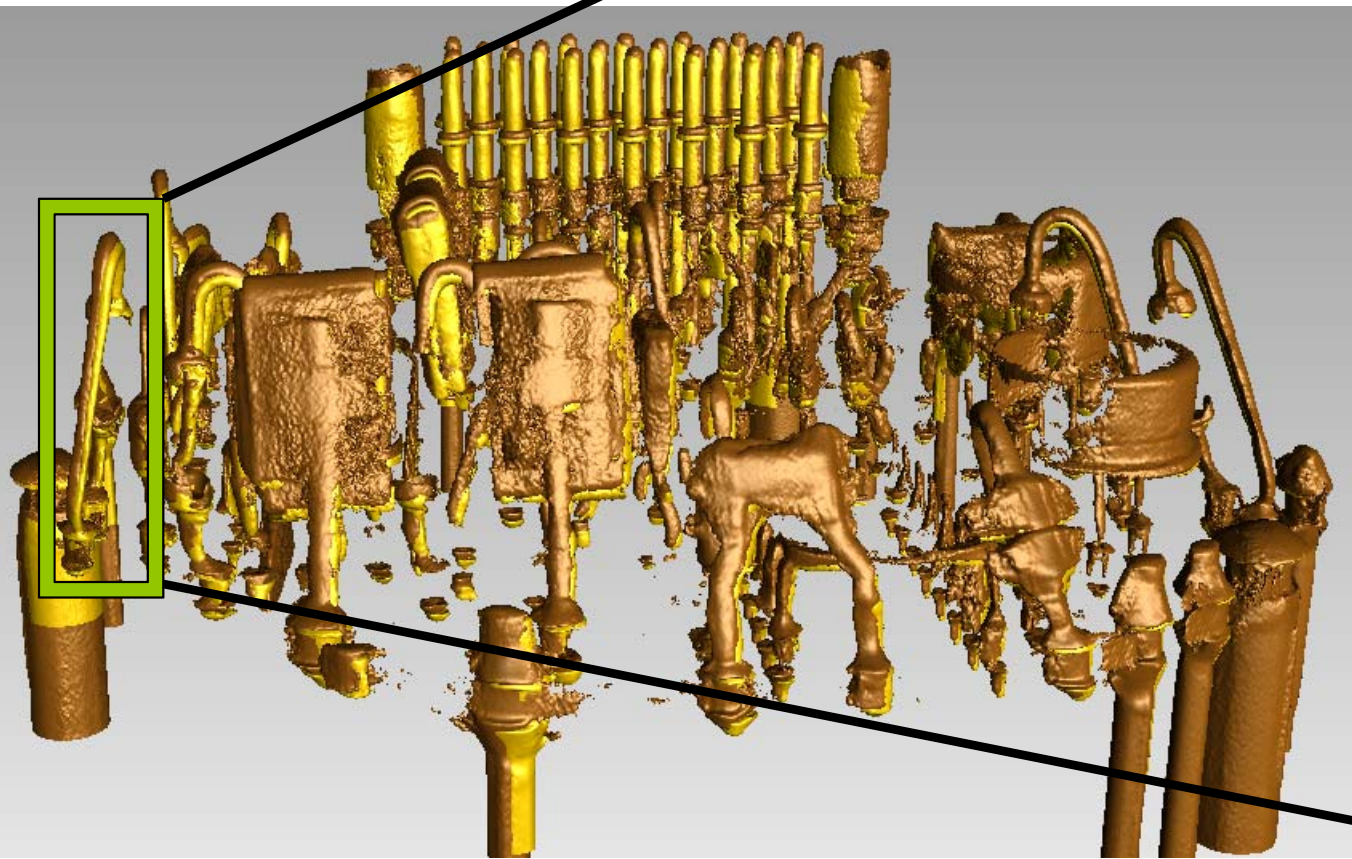

Contour Plot for Deformation using DVC

Nature of deformation from overlapping CT scan data

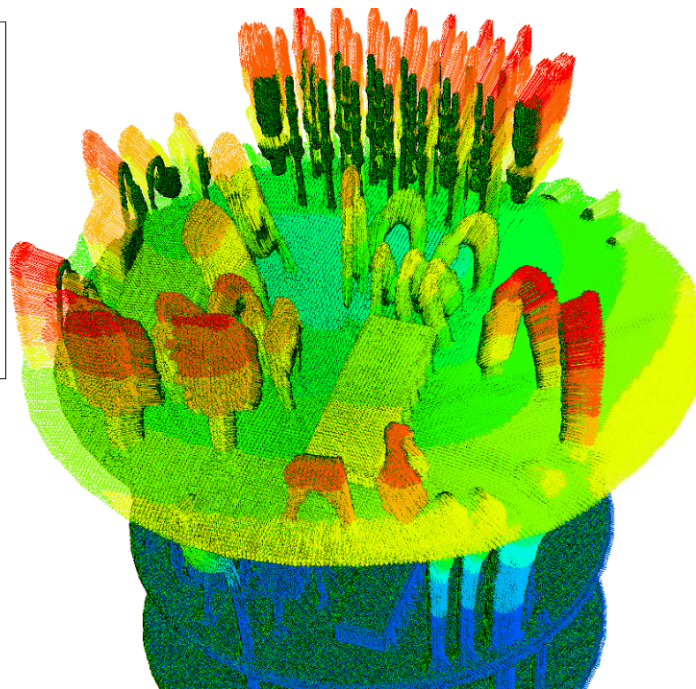
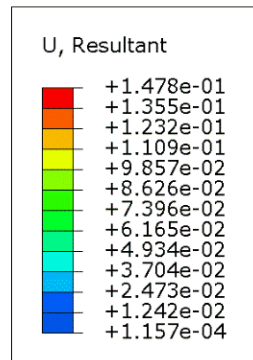

Deformation Vector Plot, Finite Element model

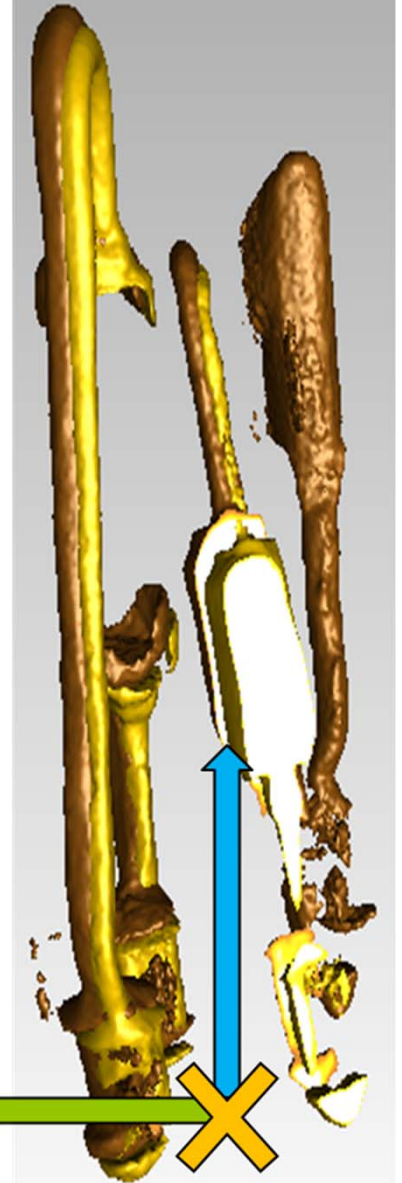

← X

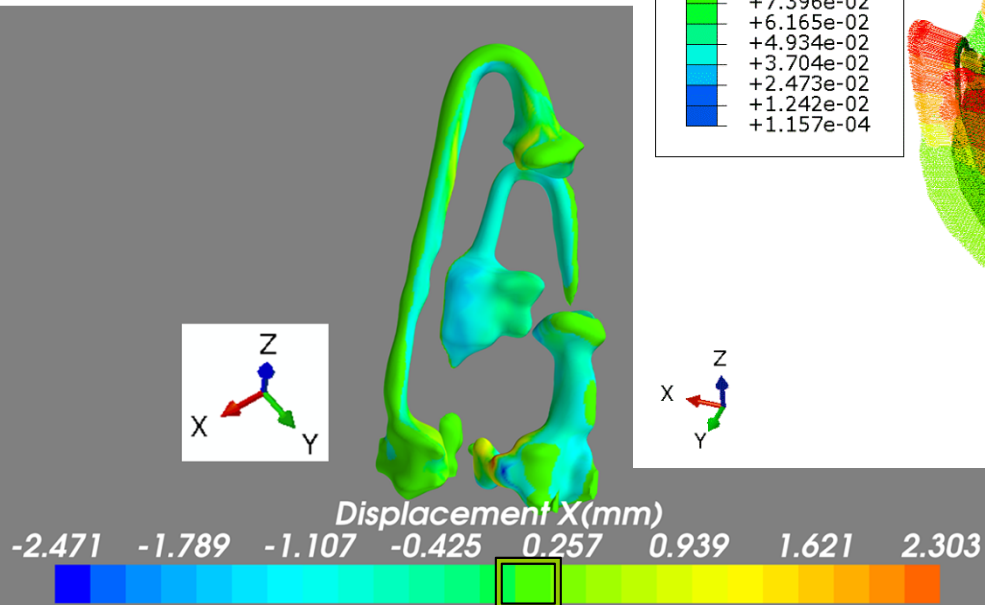

Deformation Contour, DVC

Comparison of Deformation Progressions at Location 1 & 2

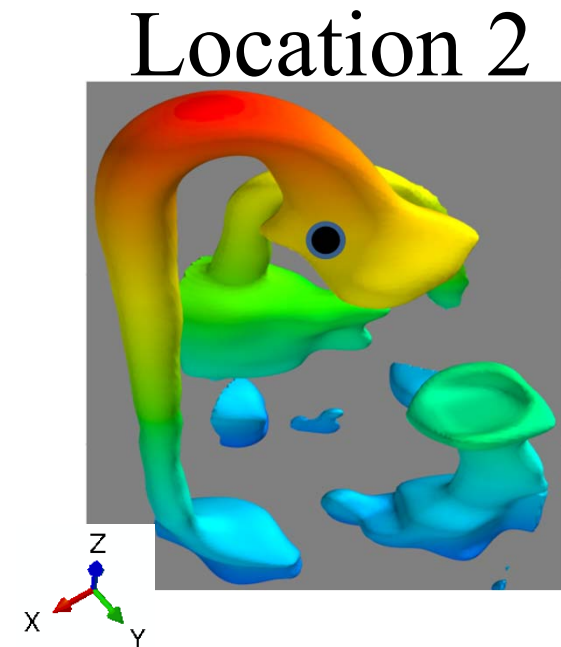
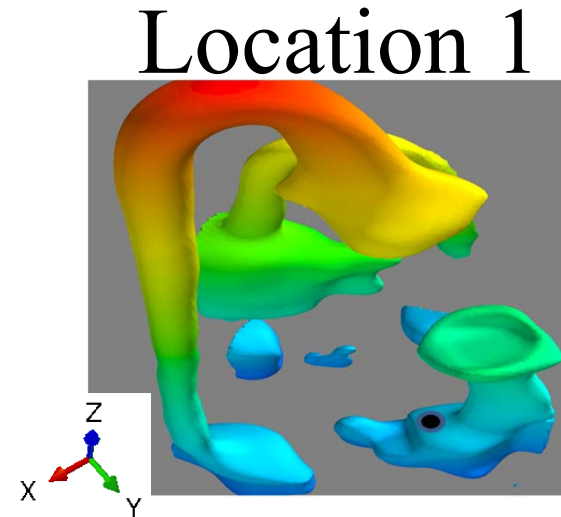
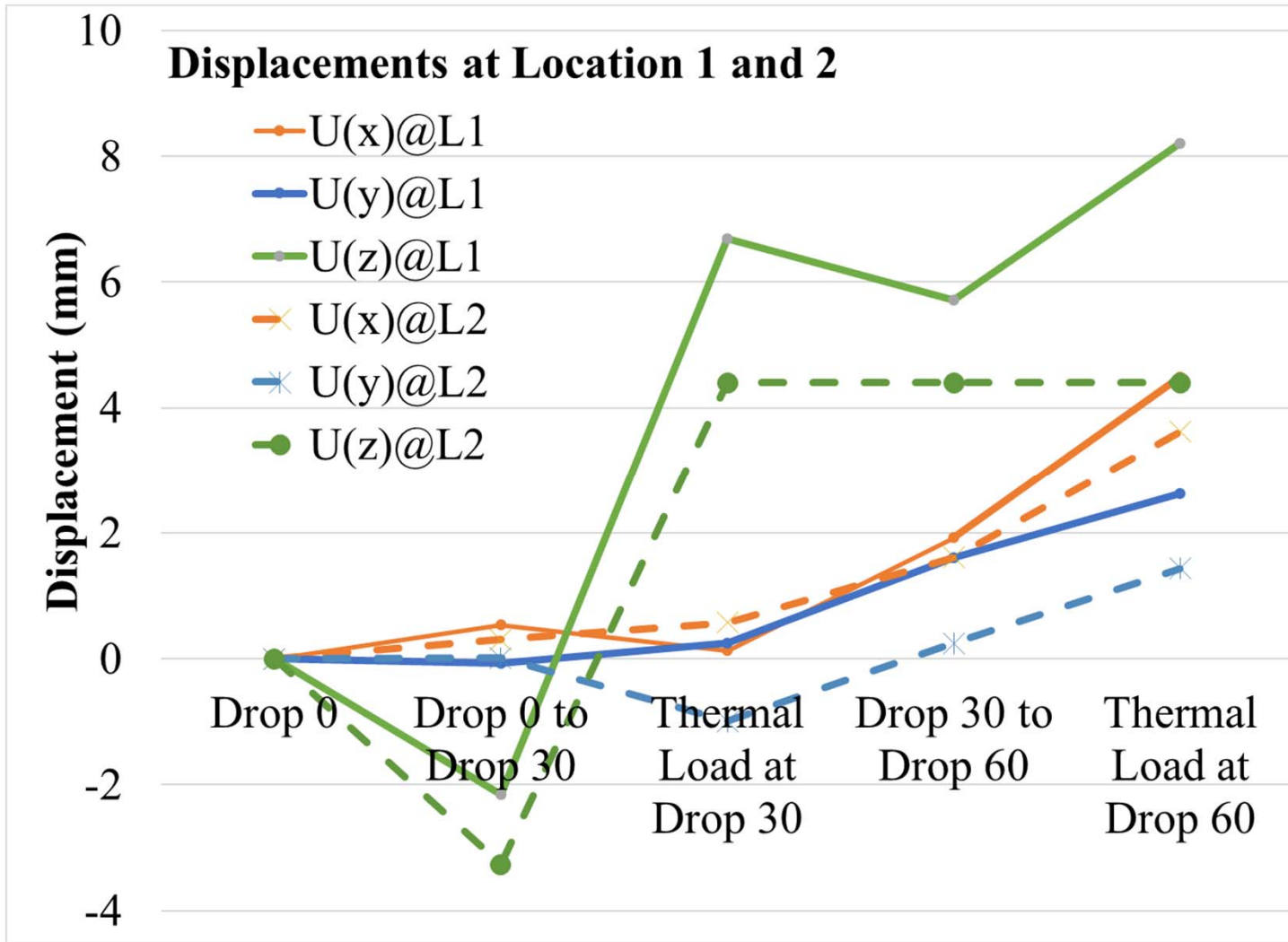

cave³

NSF Center for Advanced Vehicle and Extreme Environment Electronics



AUBURN
UNIVERSITY

Comparison of Normal Strain Progressions at Location 1 & 2

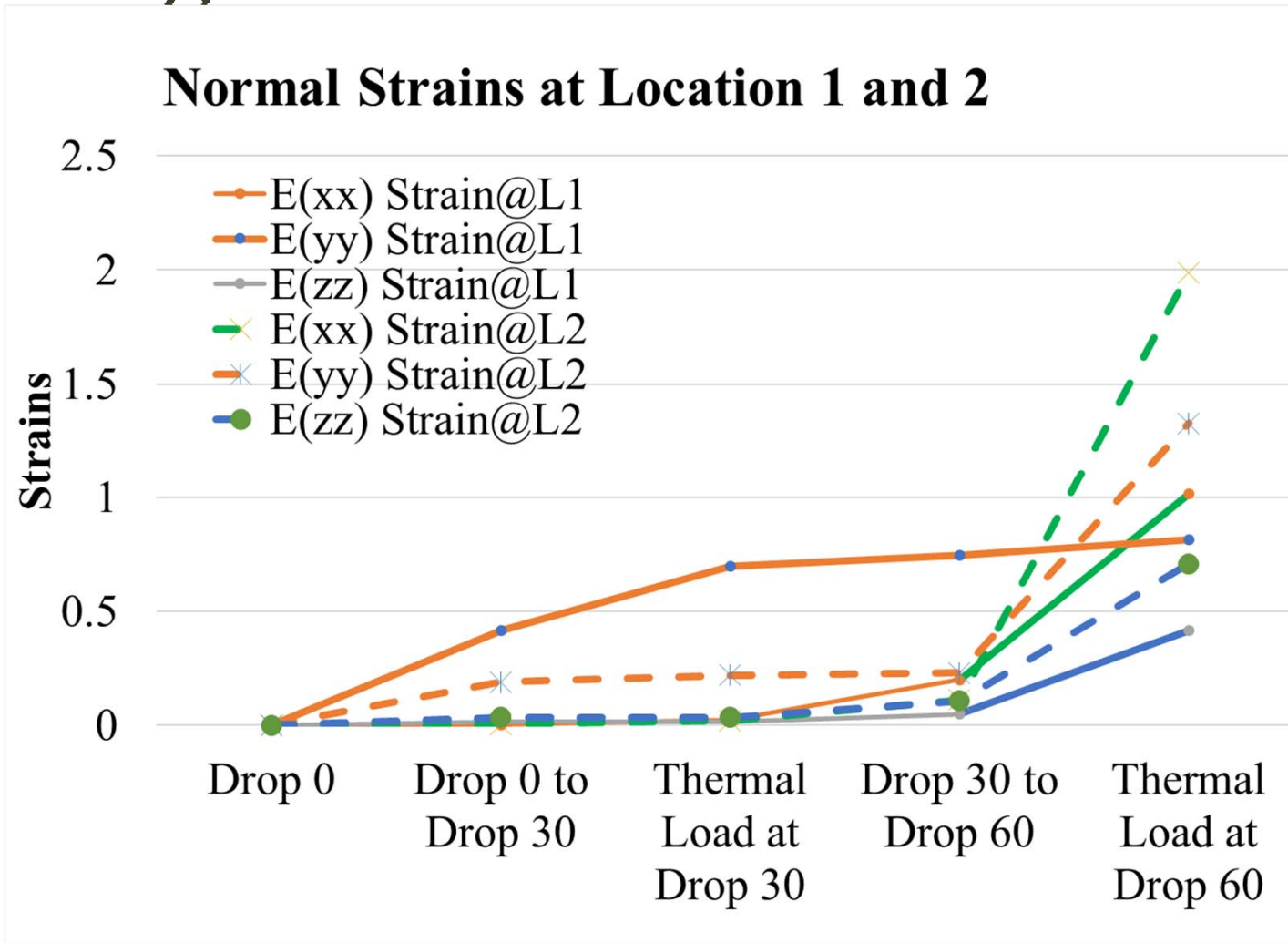

Location 1

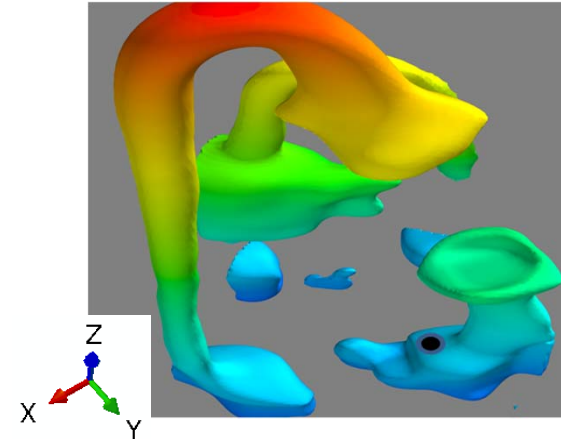

Location 2

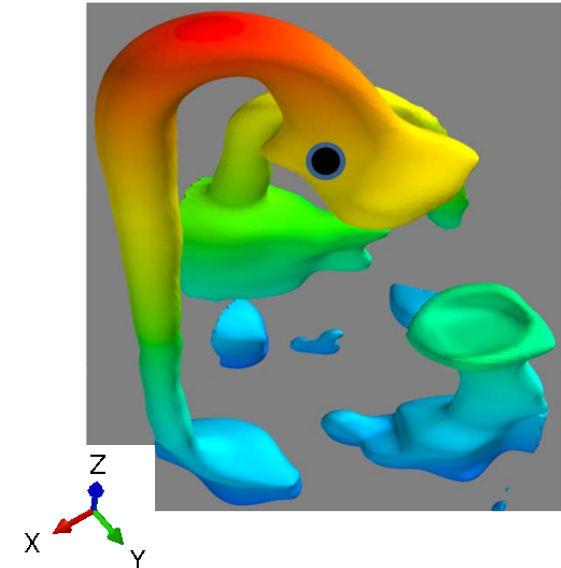

Comparison of Shear Strain Progressions at Location 1 & 2

Location 1

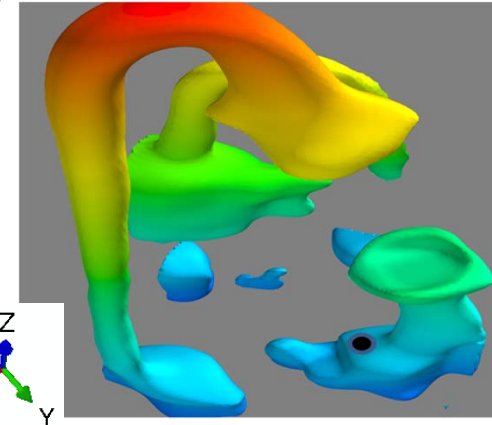

Location 2

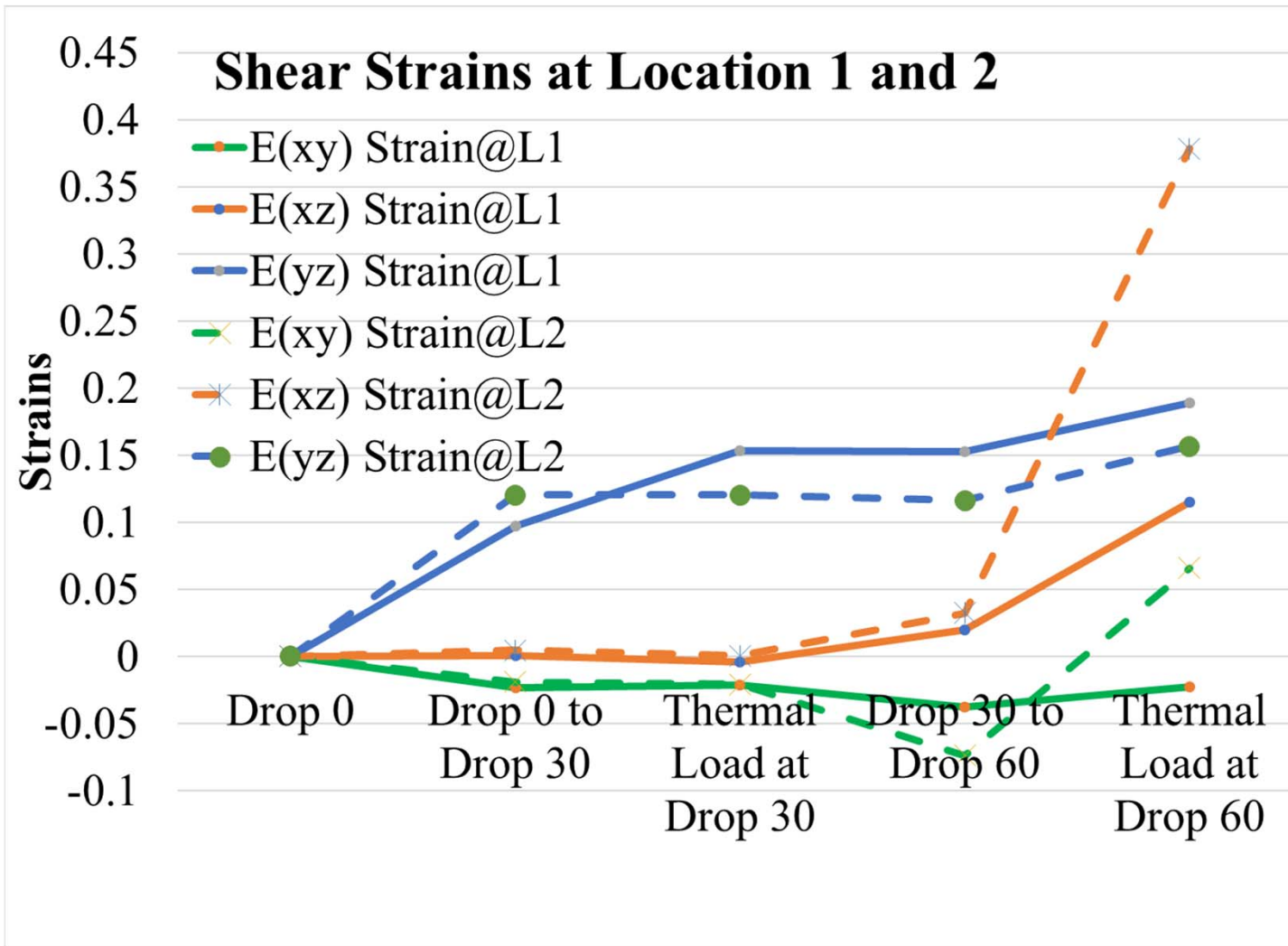
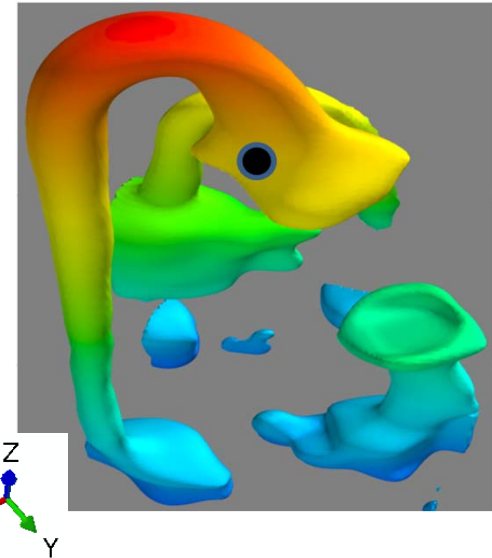

FE Results

U, Resultant

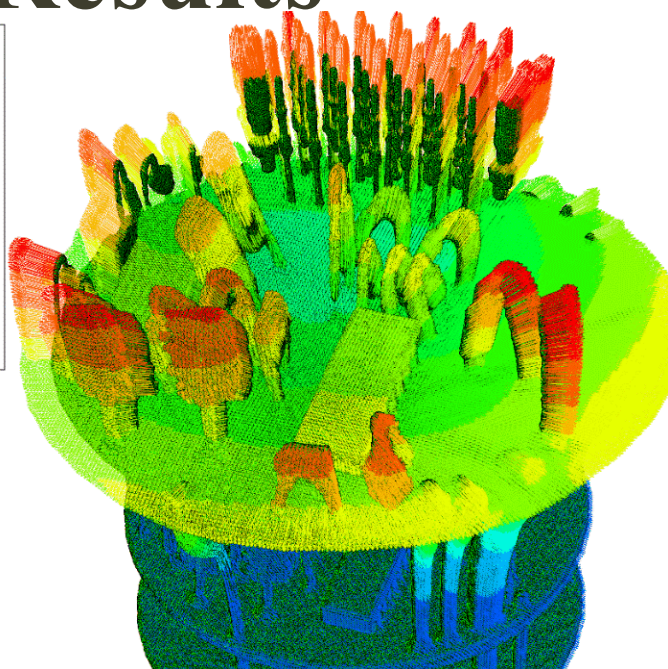
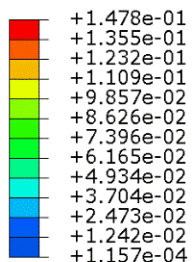

U, Magnitude

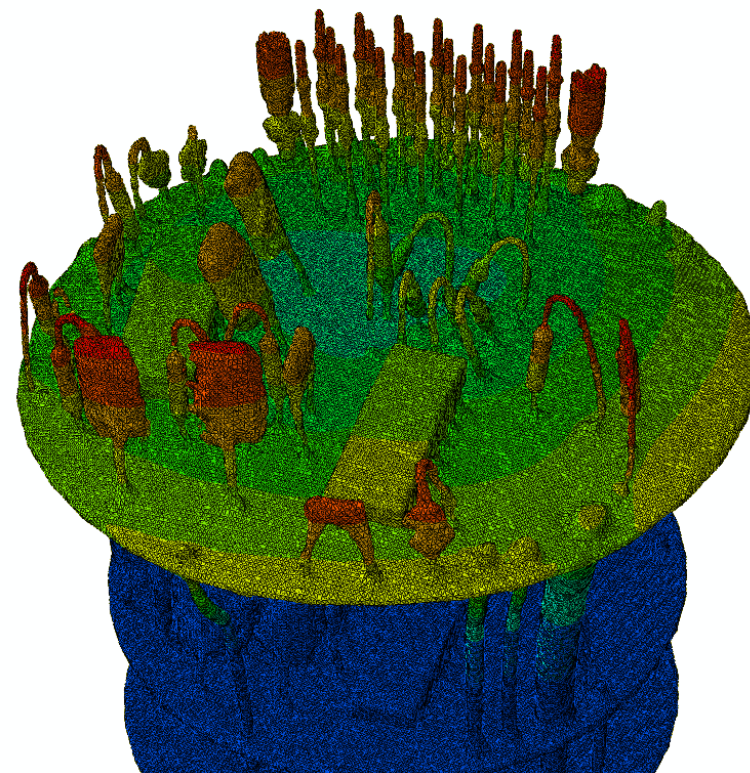
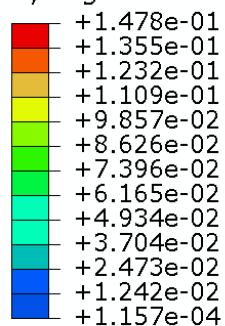

U, Magnitude

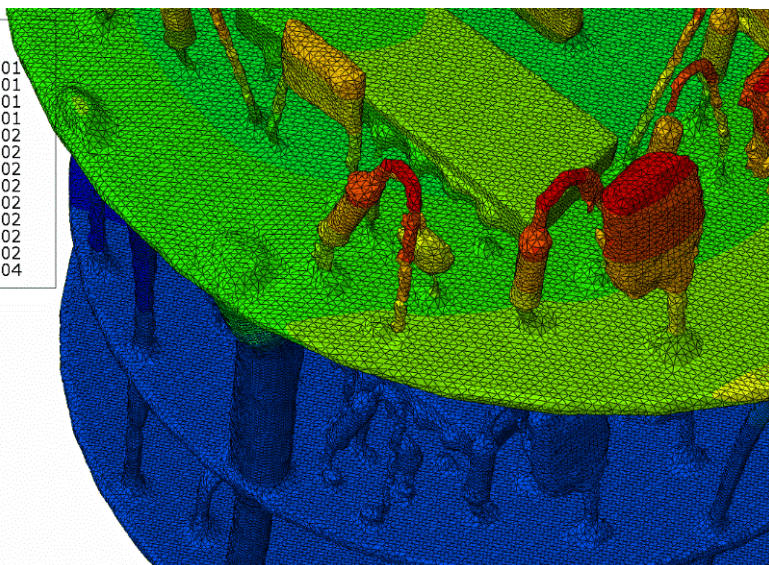
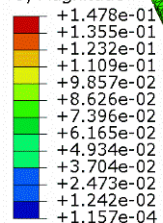

Nature of displacement: Upon thermal load the parts on the top board displace in positive z direction and radially outside

Summary and Conclusions

- In this paper we have used field extracted fuze assembly and used it for non-destructive evaluation to gauge its response to high-g mechanical shock events.
- A comprehensive fuze assembly was successfully converted into a finite element mesh , using the microCT scan data in a non-destructive way
- Electrical sub-assemblies inside of a densely packed Fuze assembly, were successfully monitored for deformations and strains in a non-destructive way over as a function of time
- The nature of deformation found on the top board assembly by overlapping the CT scan data, was found to be consistent with results from Digital Volume Correlation and micro-CT based Finite Element model results.