



**US Army Corps  
of Engineers®**  
Engineer Research and  
Development Center



## Army RCx Technical Guide

A Phased Approach for in-House or Contracted Existing Building Commissioning

Brian C. Clark, Matt M. Swanson, Sean M. Wallace,  
Eileen T. Westervelt, and Jay H. Tulley

January 2018



**The U.S. Army Engineer Research and Development Center (ERDC)** solves the nation's toughest engineering and environmental challenges. ERDC develops innovative solutions in civil and military engineering, geospatial sciences, water resources, and environmental sciences for the Army, the Department of Defense, civilian agencies, and our nation's public good. Find out more at [www.erdcd.usace.army.mil](http://www.erdcd.usace.army.mil).

To search for other technical reports published by ERDC, visit the ERDC online library at <http://acwc.sdp.sirsi.net/client/default>.

# Army RCx Technical Guide

## A Phased Approach for in-House or Contracted Existing Building Commissioning

Brian C. Clark, Matt M. Swanson, Sean M. Wallace, and Eileen T. Westervelt

*U.S. Army Engineer Research and Development Center (ERDC)  
Construction Engineering Research Laboratory (CERL)  
2902 Newmark Dr.  
Champaign, IL 61824*

Jay H. Tulley

*U.S. Army Garrison Presidio of Monterey  
Directorate of Public Works (DPW) Engineering Division  
1759 Lewis Rd  
Monterey, CA 93944*

Final Report

Approved for public release; distribution is unlimited.

Prepared for Office of the Assistant Secretary of the Army for Installations Energy and Environment (IE&E)

Under MIPR 10937859, "Development Retro-Commissioning Policy and Associated Training for Installation Energy Managers and Technicians"

## Abstract

RCx (retro-commissioning and recommissioning) is a method that combines knowledge of heating, ventilating, and air-Conditioning (HVAC) fundamentals with specific testing and analysis techniques to optimize facility energy systems and solve comfort and operations and maintenance (O&M) problems. RCx uses instrumentation and automation systems to “talk” to the facility to determine how the system is operating and how it can operate better. RCx is Congressionally mandated at specific federal facilities and is regarded by industry as a next-generation building energy management system. Yet, performing, developing, or managing successful RCx projects can be a complex process that requires facilities staff to acquire technical and soft skillsets to identify, implement, and sustain often hidden opportunities. This RCx Technical Guide uses the latest industry guidelines, standards, and studies to present “how-to” instructions for Directorate of Public Works (DPW) personnel that break RCx into discrete phases that can be contracted or performed in-house in various combinations, to map resilient RCx programs across different sized and staffed asset management organizations. This technical walk-through of each RCx phase encountered in a typical RCx event is a vital part of the personnel development needed as facilities grow more complex and as staffing challenges continue.

**DISCLAIMER:** The contents of this report are not to be used for advertising, publication, or promotional purposes. Citation of trade names does not constitute an official endorsement or approval of the use of such commercial products. All product names and trademarks cited are the property of their respective owners. The findings of this report are not to be construed as an official Department of the Army position unless so designated by other authorized documents.

**DESTROY THIS REPORT WHEN NO LONGER NEEDED. DO NOT RETURN IT TO THE ORIGINATOR.**

# Contents

<b>Abstract .....</b>	<b>ii</b>
<b>Figures and Tables.....</b>	<b>vi</b>
<b>Preface.....</b>	<b>viii</b>
<b>PART I – WHAT IS RCx? .....</b>	<b>1</b>
<b>1 Introduction.....</b>	<b>3</b>
1.1 Purpose and scope of this document .....	3
1.2 Approach to RCx .....	4
1.3 RCx cost and savings estimating.....	4
1.4 Keys to success .....	6
<b>2 RCx Resources .....</b>	<b>7</b>
2.1 Ten skills needed for RCx.....	7
2.2 RCx training opportunities .....	8
2.3 Tools .....	9
<b>3 RCx Team Roles.....</b>	<b>10</b>
3.1 In-house roles .....	10
3.2 Contracted roles .....	10
3.3 Government support .....	11
<b>PART II – HOW TO PERFORM RCx.....</b>	<b>13</b>
<b>4 Planning Phase.....</b>	<b>15</b>
4.1 Installation-level planning.....	16
4.1.1 RCx candidate criteria .....	16
4.1.2 RCx plan.....	17
4.2 Facility-specific planning.....	18
4.2.1 Utilities evaluation.....	18
4.2.2 Additional analysis .....	22
<b>5 Assessment.....</b>	<b>27</b>
5.1 Typical RCx systems to assess.....	28
5.2 General assessment strategies.....	30
5.3 Specific assessment strategies.....	33
5.3.1 Scheduling.....	34
5.3.2 Setpoint value adjustment .....	35
5.3.3 Automatic setpoint reset sequences .....	36
5.3.4 No-load disables.....	37
5.3.5 Oversized equipment .....	38
5.3.6 Load reduction .....	39
5.3.7 Variable volume.....	40
5.3.8 Equipment efficiency .....	41

5.3.9	BAS repairs .....	42
5.3.10	O&M processes.....	43
5.3.11	Human behavior and occupant comfort.....	44
5.3.12	Water savings.....	45
5.4	Assessment phase deliverables .....	46
5.4.1	RCx findings list.....	46
5.4.2	ECM checklist.....	46
5.4.3	Issues and Resolutions Log.....	47
5.4.4	Monitoring plan .....	48
5.4.5	Functional test list.....	48
5.4.6	Preliminary ECM table .....	49
5.5	RCx investigation candidates.....	49
<b>6</b>	<b>Investigation .....</b>	<b>50</b>
6.1	RCx instrumentation requirements .....	51
6.2	Monitoring plan execution .....	52
6.3	Functional testing.....	53
6.4	Data analysis .....	55
6.5	Energy calculations .....	57
6.6	Final ECM list.....	59
6.7	Issues and Resolutions Log.....	59
6.8	Investigation phase report.....	59
6.9	Design or construction improvements .....	60
<b>7</b>	<b>Implementation/Hand-Off.....</b>	<b>61</b>
7.1	Implementation execution routes.....	62
7.2	Implementation activities .....	64
7.2.1	Selection of measures.....	64
7.2.2	Implementation coordination .....	65
7.2.3	Verification of measures.....	65
7.3	Hand-off criteria.....	66
<b>8</b>	<b>Ongoing Cx .....</b>	<b>68</b>
8.1	Ongoing commissioning (OCx) process .....	69
8.2	OCx Plan outline .....	70
8.3	Common OCx activities .....	70
8.3.1	Information access .....	70
8.3.2	Targeted data analysis for new control schemes.....	71
8.3.3	Periodic or continuous benchmarking.....	72
8.3.4	Benchmarking Army buildings using MDMS .....	72
8.3.5	Ongoing monitoring.....	74
8.3.6	Data analysis.....	75
8.3.7	Notification systems.....	75
8.3.8	Automated fault detection and diagnostics .....	75
8.3.9	BAS activities.....	76
8.3.10	Periodic functional testing.....	76
8.3.11	Facilitated stakeholder discussions .....	76

---

<b>9 Deliverables Summary .....</b>	<b>77</b>
<b>10 Resources List .....</b>	<b>78</b>
10.1 RCx phases summary.....	78
10.2 CERL RCx field templates.....	78
10.3 RCx Pre-assessment checklist.....	78
10.4 Occupant thermal comfort survey.....	78
10.5 RCx SOW templates.....	78
10.6 RCx Contractor evaluation form.....	78
10.7 Example RCx report.....	78
10.8 RCx planning workshop sample agenda .....	79
10.9 Current facilities requirement (CFR) template.....	79
10.10 RCxU training checklist .....	79
10.11 CERL RCx references table .....	79
<b>Appendix A: Contact List.....</b>	<b>80</b>
<b>Acronyms and Abbreviations.....</b>	<b>81</b>
<b>Report Documentation Page (SF 298).....</b>	<b>84</b>

# Figures and Tables

## Figures

1	ASHRAE Guideline 0.2–2015 RCx phases .....	4
2	Example RCx tools and applications .....	9
3	Steps and documentation for the RCx Planning phase .....	15
4	The baseload change here reveals years of unwanted boiler operation .....	19
5	Scatter plots of interval utility may indicate important operational nuances .....	20
6	Benchmark services vary; BPD is an online option with rapid results .....	21
7	Gather whatever facility documentation is available before going on-site .....	22
8	Example weather bin data on psychrometric plots to frame climate profiles .....	23
9	Interval utility data and weather information can reveal schedule-related patterns .....	24
10	Occupant surveys are optional RCx tools to better understand building usage .....	26
11	Steps and documentation for an RCx Assessment .....	27
12	2012 CBECS energy end use breakdowns for different facility types .....	29
13	Examples of obvious indicators of performance: an Hand-Off-Auto (HOA) switch in hand mode may be accidental or indicative of a greater problem (top-left); active condensate drain may indicate unnecessary cooling (top-right); throttled pump discharge valve could mean oversized equipment (bottom-left); improperly installed sensors may be misleading control systems (bottom-right) .....	31
14	Example system diagram and library of symbols .....	32
15	Scheduling opportunities are often readily implemented at low or no cost through front-end interfaces, field-level controllers, or simple timeclocks .....	34
16	Configurable direct digital control (DDC) zone controllers facilitate ease of many HVAC setpoint valve adjustments .....	35
17	Most control systems and HVAC guidance (ASHRAE, Whole Building Design Guide [WBDG], etc.) support reset strategies .....	36
18	Air-side, heating, and cooling systems may be good candidates for no-load disables .....	37
19	Pump discharge valves offer clues into oversized equipment opportunities .....	38
20	HVAC problems are often hidden (failed economizer and simultaneous heating/cooling shown) .....	39
21	Most fan and pump motor systems can be readily retrofit for VFD applications .....	40
22	Select high nominal efficiencies in use, but focus on overall system efficiency .....	41
23	Modern BAS is comprised of many graphical interfaces, engineering tools, software plug-ins .....	42
24	Test unit efficiencies, note overrides, discuss replacements, and identify failed parts .....	43
25	Help occupants understand thermostat and zoning information with instructional signage .....	44
26	Optimize existing domestic, cooking, irrigation, and non-potable water flows .....	45

27	CERL maintains a library of RCx Assessment field sheets and other RCx templates and resources.....	47
28	Steps and documentation for an RCx Investigation .....	50
29	Typical data logger devices for RCx applications.....	52
30	Typical RCx functional test tools .....	53
31	Pre-approve, follow, and fully document procedures with a pump test form .....	54
32	Example RCx trend graph (1-week economizer performance) .....	55
33	UT3 features modules for common RCx analyses including light loads and economizer performance .....	57
34	Common energy calculations used during the RCx process .....	58
35	Issues like unnecessary discharge plenum and poor discharge fitting should be recorded as design and construction lessons learned .....	60
36	Steps and documentation for implementation .....	61
37	Stakeholder coordination can be critical, such as this example where middle of the night scheduling off of certain exterior lights required approval from the installation Safety Manager and Security Officer.....	65
38	Steps of ongoing Cx.....	68
39	LBNL's 2009 study highlights the need for sustaining or improving RCx savings.....	69
40	MDMS may help support Army installations OCx efforts.....	73
41	Data analysis continues into the OCx Phase with continuous or periodic reviews of performance .....	73
42	Level of OCx monitoring varies in complexity.....	74
43	Combining energy and weather datasets can offer highlight operations issues .....	75

## Tables

1	Preliminary RCx cost and savings estimates .....	5
2	The 10 RCx skills .....	7
3	RCx-related training opportunities and features .....	8
4	Annual CEWE/RCx plan list sample .....	17
5	Annual data can be selected and scaled toward average conditions.....	20
6	Example of how benchmarking can establish goals and improvement budgets.....	21
7	Annual O&M work order data can be valuable in preparation for RCx Assessments .....	25
8	Average energy savings impact of common RCx measures.....	33
9	Recommended RCx instrumentation range, accuracy, resolution, and calibration.* .....	51
10	Typical Excel® commands/functions and shortcuts/formulas for RCx data analysis .....	56
11	Raw and resampled interval data .....	58
12	Example RCx submittal register.....	77

## Preface

This study was conducted for the Office of the Assistant Secretary of the Army for Installations, Energy and Environment (ASA[IE&E]) via MIPR 10937859, “Development Retro-Commissioning Policy and Associated Training for Installation Energy Managers and Technicians.” The technical monitor was Paul M. Volkman, ASA(IE&E).

The work was managed by the Energy Branch (CFE) of the Facilities Division (CF) of ERDC-CERL. At the time of publication, Ms. Giselle Rodriguez was Chief, CEERD-CFE; Mr. Donald K. Hicks was Chief, CEERD-CF; and Kurt Kinnevan, CEERD-CZT was the Technical Director. The Interim Deputy Director of ERDC-CERL was Ms. Michelle Hansen and the Interim Director was Dr. Kirankumar V. Topudurti.

COL Bryan S. Green was Commander of ERDC, and Dr. David W. Pittman was the Director.

## **PART I – WHAT IS RCx?**

THIS PAGE INTENTIONALLY LEFT BLANK

# 1 Introduction

## 1.1 Purpose and scope of this document

RCx (retro-commissioning or recommissioning) is a process to optimize facility energy system performance and solve comfort and operations and maintenance (O&M) problems. Through systematic planning, fieldwork, testing, analysis, and follow-up, the RCx process can help improve facilities management programs by:

- Strategically prioritizing candidate buildings and RCx approaches
- Leveraging energy meter data to better understand facility performance.
- Emphasizing the importance of field techniques and data collection/analysis skills
- Linking engineering fundamentals, energy equations, and actual operations
- Identifying low/no-cost improvements and scoping energy-saving capital projects
- Effective use of HVAC controls and building automation systems.
- Performing post-occupancy evaluations of design and construction methodologies
- Sustaining resiliency and efficiency with current and future facility requirements.

As part of the Comprehensive Energy and Water Evaluation (CEWE) mandate in Section 432 of the Energy Independence and Security Act of 2007 (EISA 2007), RCx must be performed every 4 years on covered facilities\* that have areas greater than 50,000 sq ft (or that are otherwise energy intensive). This document is intended to provide technical guidance on *how* to perform this work. The instruction presented focuses predominantly on heating, ventilating, and air-conditioning (HVAC) and lighting energy savings; however the RCx *process* is generally applicable to other building systems (plumbing, power, envelope, etc.) and can be valuable to the facilities management as a whole.

This document walks through steps to perform RCx Assessments, follow-on investigation, and implementation. While EISA 2007 distinguishes between recommissioning and retro-commissioning based on whether initial commissioning was performed, this document considers the associated approaches and practices of existing building commissioning as effectively identical and instead uses the general term “RCx” to apply to either case.

---

\* Covered facilities are buildings designated by the installation that comprise at least 75% of an installation's energy use and are subject to CEWE and RCx requirements.

## 1.2 Approach to RCx

This document adapts the phased approach to RCx introduced in American Society of Heating, Refrigerating, and Air-Conditioning Engineers (ASHRAE) Guideline 0.2-2015, *The Commissioning Process for Existing Systems and Assemblies* (2015). Specific National Environmental Balancing Bureau (NEBB) 2009 Retro-commissioning Procedural Standard technical requirements, however, have also been included.

These discrete phases map well onto Army processes and serve as the basis for this document's layout (Figure 1). While each phase *could* be contracted, it is recommended that the Assessment Phase in particular be performed in-house to better meet the intent of EISA 2007 and drive scope development in subsequent phases. Some phases described in this document, such as Planning and Ongoing Commissioning Phases, contain tasks that are best practices, but that are less essential to the success of individual RCx efforts. Where staffing or budget is limited, focus on critical tasks in each phase as applicable or desired. See Chapter 10, "Resources List" for a summary of each phase and its associated documentation.

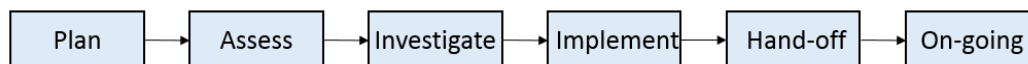

Figure 1. ASHRAE Guideline 0.2-2015 RCx phases.

## 1.3 RCx cost and savings estimating

A 2009 Lawrence Berkeley National Laboratory (LBNL) study\* of over 650 RCx projects reports median energy savings of 16% (but often exceeding 33%) at a 1.1 year payback. These results suggest RCx is a vital tool to capture "low-hanging fruit" energy savings. With its additional non-energy related benefits cited for improved O&M (14% of projects), increased productivity/safety (19% of projects), and enhanced thermal comfort (79% of projects), RCx is also often seen as a process of simply "operating the building well."

The 2009 LBNL study also provides granularity on RCx economics by utility type, facility size, and facility type. These summary findings apply to the core RCx phases (assessment through implementation) and can help provide the basis for preliminary cost and savings estimates (Table 1). It is recommended that the user tailor estimates within or projected from these

---

\* Mills, Evan. 2009. *Building Commissioning - A Golden Opportunity for Reducing Energy Costs and Greenhouse Gas Emissions*. Berkeley, CA: Lawrence-Berkeley Laboratory (LBL), <http://cx.lbl.gov/2009-assessment.html>

ranges based on actual facility conditions, operating hours, complexity of systems involved, performance benchmarking, locality cost factors, and extent of low/no-cost measures involved.

**Table 1. Preliminary RCx cost and savings estimates.\***

Category	Lower 25 Percentile	Upper 25 Percentile	Median
Energy Savings	9%	32%	16%
		Electricity	9%
		Electric Demand	5%
		Natural Gas	16%
		Central Plant	31%
RCx Cost	\$0.30/SF	\$1.50/SF	\$0.35/SF
		< 100,000 SF	\$1.15/SF
		100,000 – 250,000 SF	\$0.45/SF
		> 250,000 SF	\$0.30/SF
Simple Payback	0.2 years	2.3 years	1.1 years
		Security	3.2 years
		Lodging	1.5 years
		Instruction	1.5 years
		Office	1.1 years
		Laboratory	0.5 years
		Food Sales	0.3 years
		Healthcare (Outpatient, Inpatient)	0.1, 0.6 years

While the data in Table 1 can be preliminarily applied to individual buildings early in the RCx process, specific opportunities should be calculated using actual system data once the facility has been physically assessed. This can be done as “back of the envelope calculations” to determine order of magnitude savings during the initial assessment or in a more detailed fashion where data logging and functional testing is justified.

For example, a fan savings opportunity may be identified and roughly estimated on the spot using motor horsepower, approximated load factor, assumed efficiencies, and facility schedule. These savings estimates can then be refined in a follow-up investigation in which instrumentation is used to determine actual motor load at different operational conditions, and fan runtime is verified with portable data loggers or building automation system trends.

\* Savings are weather normalized; costs are averaged across continental U.S. sites and adjusted for inflation from 2009 LBNL RCx study and include utility rebates and RCx provider fees.

## 1.4 Keys to success

To achieve successful RCx efforts, several key factors must be considered early in the process. Regardless of phase or provider, the biggest keys to RCx success are:

1. *Clarity.* Make it clear to RCx contracted or in-house staff the phases, tasks, systems, and deliverables that are included in your project. Even when working with certified providers, “RCx” can mean different things to different individuals and organizations.
2. *Priority.* Use benchmarking tactics, utility data analysis, and engineering judgment to focus attention on energy, cost, O&M, and comfort drivers. Try not to go into a building blind or to needlessly expand testing and analysis scope to all systems without assessing them first.
3. *Comprehensiveness.* For facility systems selected, make sure the level of detail in your RCx effort is commensurate with the scope and complexity of your RCx goals. According to the 2009 LBNL study, projects using a comprehensive approach to RCx attained almost twice the median savings and five times the savings of the least thorough projects. Some conditions that will impact comprehensiveness of an RCx effort include metering or automation data, facility documentation, staffing, and budget available.
4. *Systems-Thinking.* Remember that the building knows how it is operating and we need not rely solely on rules of thumb, anecdotes, or intuition to guess at RCx solutions. Craft the right trends and tests that will deliver the critical data you need. Consider how energy savings reverberate across systems.
5. *Coordination.* It takes a team of dedicated individuals to prep, access, control, test, analyze, document, improve, and perform measurement and verification (M&V) of our buildings and their performance during the various phases of any RCx effort. Coordinate early and keep key stakeholders like O&M technicians, building automation system (BAS) operators, occupant representatives, and Information Technology (IT) personnel in the loop.

## 2 RCx Resources

Table 2 summarizes skills, tools, and roles required for performing or managing RCx tasks. Chapter 10, “Resources List” includes a full list of resources available including RCx field sheets, references, and templates.

### 2.1 Ten skills needed for RCx

Many RCx training programs indicate specific skills required to be active in RCx endeavors. Table 2 lists 10 such skills considered critical to involvement with Army RCx projects and the difficulty estimated with their acquisition. We recommend a self-assessment of these skills with current staff to determine competency gaps and training, staffing, or contracting needs.

Table 2. The 10 RCx skills.

#	Name	Description	Difficulty
1	HVAC Fundamentals	Familiarity with how HVAC loads, equipment, and controls operate	High – this is the broadest skill and requires both physics and field knowledge
2	Benchmarking and Utility Analysis	Ability to interpret overall facility performance patterns	Low – interval data can be harder to interpret but overall the difficulty is low
3	RCx Scoping	Ability to identify systems, performance indicators, and opportunities	Moderate – this is essentially an enhanced energy and water evaluation
4	System Diagramming	Firm grasp of system concepts and how to diagram system configurations	Moderate – field-charting complex piping or air-side networks can be difficult
5	Trending	Understanding facility trend features, supplementing with portable loggers	Moderate – launching and reading portable data loggers requires practice
6	Functional Testing	Familiarity with testing techniques to quantify or qualify system response	High – it can be difficult to draft, perform and manage safe and effective field tests
7	Data Analysis	Knowing how to manipulate collected data to interpret facility operation	High – can require advanced use of Excel® and other data analysis tools
8	Energy Calculations	Familiarity with basic HVAC and energy formulas to model system changes	Moderate – use of standard techniques and equations from HVAC Fundamentals
9	Return on Investment (ROI) Calculations	Understanding how to estimate implementation costs and payback	Low – this should be an established skill for facility and energy management staff
10	Implementation	Knowing execution strategies, coordination, and retesting needed	Moderate – this is the most critical skill and perhaps hardest to do well

## 2.2 RCx training opportunities

While this document can function as a standalone technical instruction for Army RCx tasks, it is also intended to serve as the companion guide to the U.S. Army RCx Practicum. The U.S. Army RCx Practicum is a training event that features hands-on practice of RCx field skills and actual scoping, testing, analysis, and implementation for RCx opportunities that meet Army requirements. This training has been historically offered once a year as an “over the shoulder” instruction on actual Army RCx projects; however recent sessions have offered a preparatory remote learning component that culminates with the on-site portion.

Table 3 lists and summarizes several related training opportunities that can be used to supplement RCx competency gaps. Whenever possible, we recommend training opportunities that feature hands-on RCx instruction.

**Table 3. RCx-related training opportunities and features.**

Source	Title	Components	Certification	Cost
U.S. Army	RCx Practicum	6 weeks remote, 1 week field practice	None	No (TDY* costs only)
Pacific Northwest National Laboratory (PNNL)	Building Retuning Training	Online only, self-paced	None	No
Utility Company Example: Pacific Gas & Electric (PG&E)	Existing Building Commissioning Workshop	12 monthly field-lecture sessions	None	No
University of Wisconsin-Madison (UW-M)	UW-Madison Commissioning Process Certifications	2-5 day seminar/exam	QCxP, CxM, CxP Certificate	Yes
National Environmental Balancing Bureau (NEBB)	Cx Process Professional Certification Program	Self-study and exam	Building HVAC Controls System (BCS) Certificate	Yes
ASHRAE	Commissioning Process Manager Professional	Self-study and exam	CPxP	Yes
AABC Cx Group (ACG)	Certified Commissioning Authority Certification	Self-study and exam	CxA	Yes
TABB (Testing Adjusting and Balancing Bureau)	Commissioning Supervisor Certification Program	Self-study and exam	TABB Cx Supervisor	Yes
Building Commissioning Association (BCA)	Commissioning Provider Certificate Program	Self-paced remote, 1 week seminar	CxP Certificate	Yes
Association of Energy Engineers (AEE)	Existing Building Cx Professional Certification Program	Seminar and exam	Existing Building Commissioning Professional (EBCP)	Yes
*Temporary Additional Duty (travel) (TDY)				

## 2.3 Tools

In addition to RCx skillsets, specific pieces of data logging and testing equipment are often required to support RCx activities. Regardless of which RCx phases Army installations plan to contract rather than perform in-house, it is important to have awareness of the types of field tools available and their typical RCx uses. While many types of facility instrumentation exist, Figure 2 shows common devices available for loan to Army facilities staff through the Army's RCx Equipment Lending Library.\*

Figure 2. Example RCx tools and applications.

<p><i>Portable Data Loggers</i></p>  <p>For collecting air/surface temperature, humidity, amperage, light, occupancy, motor, or CO2 data</p>	<p><i>Infrared Thermometer</i></p>  <p>Measures surface temperature from afar (diffuser, piping, steam trap, etc), AKA IR gun</p>	<p><i>Power Meter</i></p>  <p>Records large 3-phase current and voltage data (eg, chiller or whole building kW logger)</p>
<p><i>Environmental Meter</i></p>  <p>Gives spot readings of temp, humidity, light, and air velocity</p>	<p><i>Thermal Camera</i></p>  <p>Provides thermal images to evaluate heat/air leakage</p>	<p><i>Combustion Analyzer</i></p>  <p>Measures the flue exhaust by-products and burner efficiency</p>
<p><i>Clamp-on Ammeter</i></p>  <p>For clamp-on current, voltage, and resistance measurements</p>	<p><i>Stroboscope</i></p>  <p>Helps determine rotational speed and load of HVAC motors</p>	<p><i>Hydro-manometer</i></p>  <p>Reads low, high, and differential water-side pressure (for pump tests)</p>

\* For a full list of tools available for loan through the Army's RCx Equipment Lending Library, contact the U.S. Army Corps of Engineers Engineering Research Development Center, Construction Engineering Research Laboratory (USACE ERDC-CERL) at 217-373-3338.

## **3 RCx Team Roles**

### **3.1 In-house roles**

Ideally, all RCx work could be performed by in-house government staff familiar with the building and with the skillsets and tools to properly measure, change, and monitor system operations. In practice, however, most Army DPWs will not have adequate capacity and may instead focus on phases like Planning and Assessment that most benefit from in-house direction. Regardless, team members should include:

- DPW Energy Manager or Facilities Engineer – to perform core RCx tasks
- DPW BAS Operator – to facilitate assessment and operation of the BAS (if in-house)
- DPW Engineering or O&M Technicians/Electricians – to assist with RCx activities
- DPW Utility Specialist – to coordinate local utility rebate application and inspections
- DPW Engineering and O&M Chiefs – to support implementation of RCx measures
- Facility Manager – to act as building representative and relay data and other requests
- IT Technician – if BAS access is required and special access/troubleshooting is required
- Installation Safety Manager and Security Officer – to concur on changes as necessary.

### **3.2 Contracted roles**

When contracting for RCx-related services, make sure to clearly define the phases, tasks, and deliverables required (template statement of work [SOW] documents are located in Chapter 10, “Resources List”). Possible contracted support may include:

- O&M Technician/Electrician – to support RCx tasks via base O&M contract work order
- BAS Programmer – to support BAS evaluation, testing, changes, or ongoing Cx
- Energy Consultant or RCx Provider – to oversee specific RCx phases
- Equipment Vendors – to coordinate equipment tests, checks, or changes

- TAB (Testing, Adjusting, and Balancing) Contractor – when an RCx Assessment determines balancing is required
- Mechanical/Electrical Contractor – to perform Implementation phase tasks as necessary.

### **3.3 Government support**

Several reimbursable government support mechanism exist to support installations in various RCx phases, including:

- U.S. Army Corps of Engineers (USACE) ERDC-CERL – provider of RCx services, training, and tools
- USACE Commissioning Center of Expertise in Sustainability – for Cx and RCx criteria
- PNNL – the Pacific Northwest Lab has a retuning program for BAS-specific measures
- EACA/EAPP/IMCOM REMs (U.S. Army Installation Management Command)\* – for central support during 4-year energy audits and RCx
- USACE Huntsville District – to contract fixed-cost or financed RCx services.

---

\* Energy Awareness and Conservation Assessments (EACA); Energy Engineering Analysis Program (EAPP); Resource Efficiency Manager (REM)

THIS PAGE INTENTIONALLY LEFT BLANK

## **PART II – HOW TO PERFORM RC<sub>x</sub>**

THIS PAGE INTENTIONALLY LEFT BLANK

## 4 Planning Phase

The Planning phase (Figure 3) can consist of a combination of installation-level planning and facility-specific planning. The goal of installation-level planning is to establish and prioritize a set of candidate buildings for RCx Assessments. The goal of facility-specific planning is to compile and evaluate facility documentation in preparation for an RCx Assessment.

In-house completion of Planning phase tasks is preferable; however, if DPW staff is limited, it may be necessary to rely on external support, or to focus on key planning steps only.

Regardless, some level of planning must occur before arriving on-site to ensure that the RCx Assessment process is strategically executed with valuable results. What facilities should be assessed, and in what priority? Which systemic issues or pervasive opportunities are specific to your installation that should be included in the Assessment? And are there clues about potential energy drivers you can derive from utility data, as-builts, climate trends, or occupant usage? Consider the steps given in this chapter as a guide for how to approach RCx Planning.

Figure 3. Steps and documentation for the RCx Planning phase.

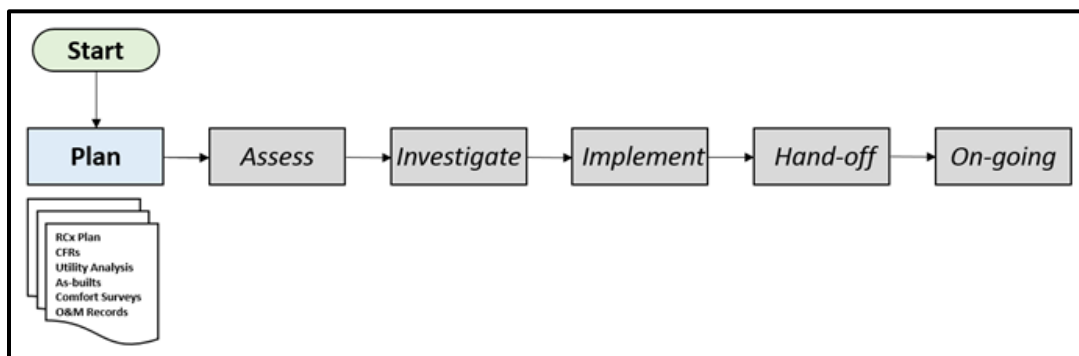

## 4.1 Installation-level planning

### 4.1.1 RCx candidate criteria

Due to their detailed nature, RCx Assessments should be limited to facilities that meet specific size or operational criteria. Following U.S. Department of Energy (USDOE) Guidelines on EISA 2007 compliance,<sup>\*</sup> establish the initial RCx candidate pool from designated covered<sup>†</sup> facilities that are greater than 50 thousand square feet (KSF) and facilities greater than 25 KSF that house energy intensive operations. In the context of RCx Planning, the following facility types should be considered energy intensive:

- Data centers
- Dining facilities
- Central plants
- Hospitals/clinics.

When not meeting the above criteria, the following facility types are recommended for inclusion as RCx candidates due to their mission criticality or high probability for RCx opportunities:

- Headquarters buildings
- Barracks
- Childcare/schools/youth centers
- Leadership in Energy and Environmental Design (LEED) Silver-certified projects<sup>‡</sup>
- Laboratories
- Food sales
- Assembly
- Other facilities designated by the installation as critical (i.e., in Energy Security Plan)
- Other facilities identified by O&M staff with recurring maintenance/comfort problems.

---

<sup>\*</sup> Facility Energy Management Guidelines and Criteria for Energy and Water Evaluations in Covered Facilities (42 U.S.C. 8253 Subsection (f), Use of Energy and Water Efficiency Measures in Federal Buildings), 25 November 2008.

<sup>†</sup> *Covered facilities* are defined as the real property buildings that comprise 75% of an installation's reported energy usage.

<sup>‡</sup> Government and industry reports indicate that DoD projects certified or considered "certifiable" through the Leadership in Energy and Environmental Design (LEED) are good RCx candidates due to their heavy use of automations systems, relative complexity, and opportunities for optimization.

#### 4.1.2 RCx plan

An RCx Plan documents the approach taken to installation RCx. At a minimum, it should record the list of RCx candidates identified and some indication of which RCx Assessments will be performed when and by whom similar to the listing in Table 4.

Table 4. Annual CEWE/RCx plan list sample.

Bldg	Type	Size (KSF)	Gas (therms)	Elec (kWh)	Elec Meter*	Total MMBtu	% of Total Energy	RCx Candidate?	RCx Assessment Fiscal Year (FY)
A	Dining	28.2	43,200	429,300	Utility	5,780	2.4%	Yes - intensity	FY18 - USACE
B	Barracks	23.0	28,800	137,300	MDMS**	3,350	1.2%	Optional - mission	FY19 - Energy Mgr
C	Clinic	30.2	16,200	524,100	Utility	3,410	1.1%	Yes - intensity	FY18 - USACE
D	Instruction	79.6	13,100	583,800	Utility	3,300	0.9%	Yes - size	FY19 - Energy Mgr
E	Data Center	12.5	-	410,600	(SF-based)	1,400	0.6%	Optional - mission	FY20 - REM
F	Fitness	68.5	14,400	424,300	MDMS	2,890	0.5%	Optional - size	-
G	Admin	42.4	5,400	137,900	MDMS	1,010	0.7%	No	-
X	Warehouse	79.6	5,600	288,100	Utility	1,540	0.3%	Yes - size	FY21 Energy Mgr
Y	Admin	48.5	7,400	280,900	(SF-based) approx.	1,700	0.3%	No	-
Z	Warehouse	42.2	5,400	149,400	MDMS	1,050	0.2%	No	-
Tot	All Covered	2,680	890,000	25,110,100	-	177,210	75%	# of covered bldgs.	# per year
Tot	All RCx	775	280,000	12,950,000	-	72,180	30%	# of RCx bldgs.	# per year
<p>* Where no utility meter or MDMS data exists, use square footage-based approximations using similar facility intensities on the installation or climate-specific intensities from Sustainable Design and Development (SDD) Policy Update Memo dated January 17 2017</p> <p>** Maintenance Data Management System (MDMS)</p>									

While a spreadsheet list of buildings similar to Table 4 could constitute an installation's RCx Plan, a best practice is to develop a more comprehensive report that specifies installation-tailored strategies for accomplishing RCx. Chapter 10, "Resources List" contains a sample RCx Planning Workshop Agenda that could help guide the development of an enhanced RCx Plan, with potential report topics that may include:

- review installation performance goals
- perform installation-level benchmarking
- prioritize key RCx success metrics
- list RCx execution options by phase
- capture general facility requirements
- craft occupant comfort surveys
- compile RCx template documentation
- determine energy, water, or cost reduction targets

- list known energy, O&M, or comfort challenges
- identify in-house capabilities and resources
- discuss RCx roles and responsibilities
- identify critical RCx measures to include
- evaluate O&M questionnaires
- create measurement and verification standards.

Given the overlap between determining candidates and strategies for comprehensive energy and water evaluations (CEWEs) vs. RCx, consider combining planning efforts into a common spreadsheet or document as an additional best practice as shown in Table 4.

## 4.2 Facility-specific planning

In preparation for an RCx Assessment at one of your facilities, some data-based speculation on the building's energy drivers is required to ensure strategic use of time on-site. The most important step is to employ some level of utility data evaluation, though additional time spent reviewing as-built construction documents, climate data, interval meter data, O&M records, occupant surveys, and previous audits or assessments should be considered best practice.

### 4.2.1 Utilities evaluation

Begin by collecting and graphing any monthly utility meter data available for the building. Preferably, a 2-3 consecutive years' worth of each utility type can be plotted on a single time-series chart. For billing gaps or large shifts in billing cycles, consider using a tool to adjust or average data accordingly.\*

You want to get an understanding for how the building performance changes over time. Look for patterns and profiles, large or erratic shifts in magnitudes over months or years. Does gas consumption drop off in the summer entirely, maintain a baseload for domestic water heating, or linger in ways that suggest excessive reheat or simultaneous heating and cooling? Consider electricity; does it gradually swing in ways that reflect expected cooling and occupancy trends or can you see too much (or perhaps not

---

\*e.g., California Commissioning Collaborative's *Utility Consumption Analysis Tool (UCAT)* spreadsheet, [http://www.cacx.org/resources/rcxtools/spreadsheet\\_tools.html](http://www.cacx.org/resources/rcxtools/spreadsheet_tools.html)

enough) variation in annual usage that requires a closer look at HVAC or lighting schedules and sequences when you arrive on-site?

Figures 4 and 5 show how patterns in utility billing and interval energy data can reveal building performance issues.

Calculate a single energy use index (EUI) for the building by combining annual utility consumption in common units (e.g., kBtu) and dividing by total gross square footage.\* When it is unclear how annual weather changes may have affected facility energy usage, consider using heating and cooling degree day (HDD and CDD<sup>†</sup>) data to qualify or normalize performance. Annual utility data can be slightly scaled toward average conditions or, with multiple years, selected to best match average conditions (Table 5).

Figure 4. The baseload change here reveals years of unwanted boiler operation.

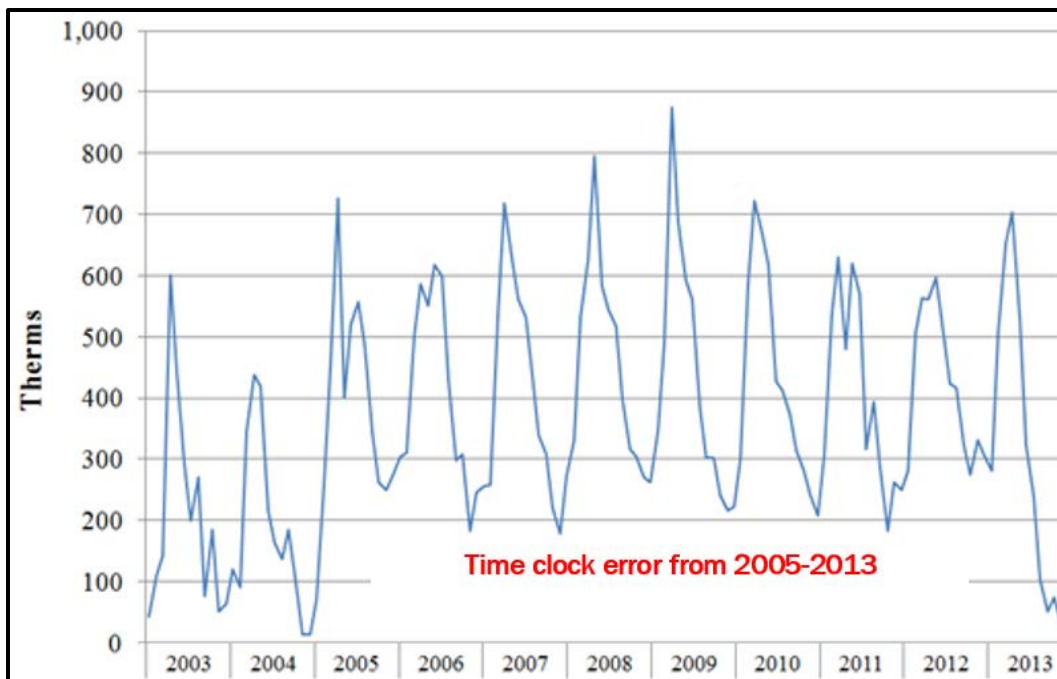

\* [https://www1.eere.energy.gov/femp/pdfs/eisa432\\_guidance.pdf](https://www1.eere.energy.gov/femp/pdfs/eisa432_guidance.pdf)

† HDDs and CDDs are calculated as the difference between a day's average temperature and some balance temperature (e.g., 65 °F) where no heating or cooling is needed, typically summed over the year. Resources such as the [National Climate Data Center](#) and [Weather Underground](#) publish design and observed HDD/CDD data.

Figure 5. Scatter plots of interval utility may indicate important operational nuances.

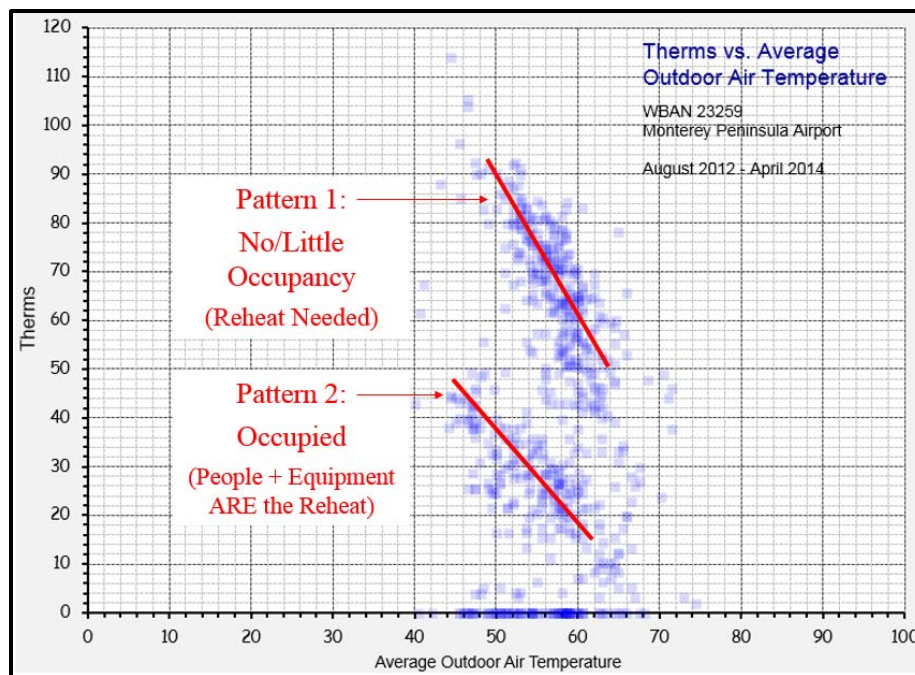

Table 5. Annual data can be selected and scaled toward average conditions.

FY	HDD	CDD	Bills Available
2014	2,442	112	1
2015	2,005	211	12
2016 (closest to average)	2,703	71	12
2017	—	—	1
10-year Average	2,964	76	—
2016 Scaling Factors	1.097	(negligible)	—

Establish a benchmark by comparing facility EUI to some peer group that accounts for climate and building type (see Figure 6). Possible peer group sources include:

- Department of Energy's *Building Performance Database*  
<https://energy.gov/eere/buildings/building-performance-database>
- Energy Star's *Portfolio Manager*,  
<https://www.energystar.gov/buildings/facility-owners-and-managers/existing-buildings/use-portfolio-manager>
- Part I Table 1 of this document (LBNL RCx savings summaries)
- 2017 Sustainable Design and Development Policy Update.\*

\* Department of the Army, Assistant Secretary of the Army (Installations, Energy, and Environment). Memorandum. Subject: Sustainable Design and Development Policy Update (Energy Use Intensities Tables). 17 January 2017.

Figure 6. Benchmark services vary; BPD is an online option with rapid results.

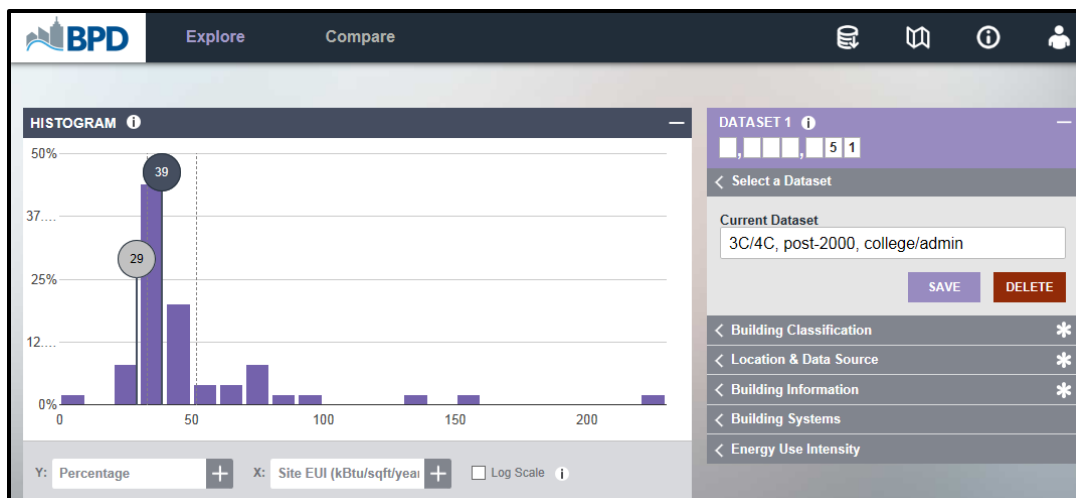

Having a benchmark can help you understand what level of energy savings may be reasonable to expect at your building (Table 6). As an extra step, translate the delta between your building’s annual EUI and its peer benchmark into a potential energy costs savings estimate or range and use payback criteria to put a preliminary cost cap on any capital improvement opportunities you may find.

Table 6. Example of how benchmarking can establish goals and improvement budgets.

Utility	Baseline	LBNL Median RCx Savings			Target EUI	Payback Term	Proposed Improvement Budget
Natural Gas (therms)	13,227	16%	2,116	\$2,322	26.8 kBtu/SF	15 years	\$135K
Electricity (kWh)	503,857	9%	45,347	\$6,649			
Total (MMBtu)	3,042	12%	366	\$8,970			

Keep in mind, however, that these preliminary benchmarking figures cannot account for specific facility operations, and that even well-benchmarked buildings may have room for improvement (particularly through the optimization of BAS controls sequences).

If no comparable facility data can be found to benchmark your facility, benchmark your facility’s energy use over time against itself to see relative changes in operations. If clear correlations exist between energy usage and weather, it will be possible to normalize apparent changes from baseline performance.

## 4.2.2 Additional analysis

After some level of basic utilities evaluation, consider additional analysis using as-builts, climate data, interval utility data, or occupant/O&M information to add insight into system operation and performance issues.

Start by taking a cursory look through as-built equipment schedule, schematic, and floorplan sheets to get an idea for facility system types, configurations, and loads to expect (Figure 7). You may also want to compile any recent HVAC controls, O&M manuals, or TAB documentation available.

Figure 7. Gather whatever facility documentation is available before going on-site.

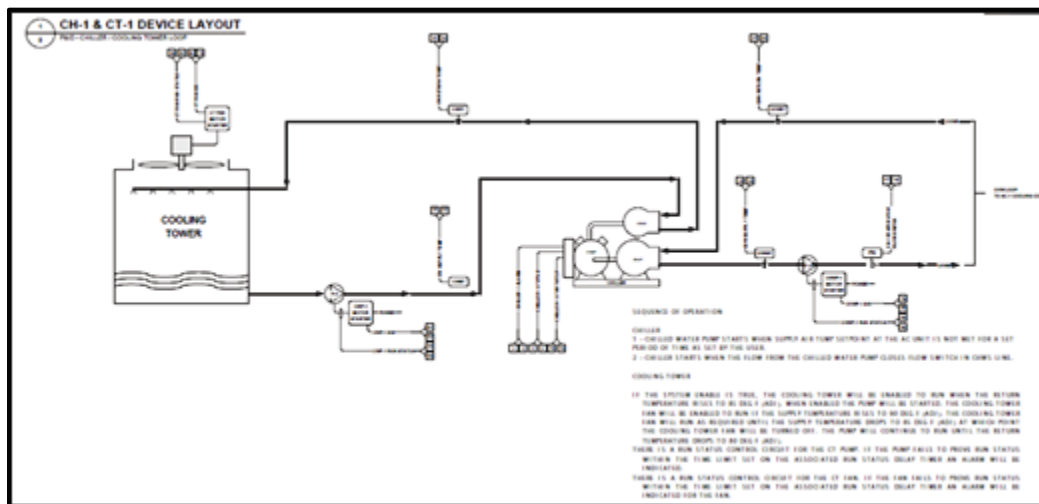

It is important to also think about your facility's operational needs in the context of the climate it operates in. Bin weather data plotted on a psychrometric chart\* can quickly acclimate you to the distribution and severity of weather conditions your building sees (Figures 8 and 9). When would you expect load management equipment to lockout, economizers to switch to minimum, or air-side systems to throttle? Having a good idea to these answers ahead of time will help better frame what you see in the field.

\* Hourly weather station data can be obtained through the National Climate Data Center (NCDC):  
[ftp://ftp.ncdc.noaa.gov/pub/data/EngineeringWeatherData\\_CDROM/engwx/handbook.pdf](ftp://ftp.ncdc.noaa.gov/pub/data/EngineeringWeatherData_CDROM/engwx/handbook.pdf),  
[http://web.utk.edu/~archinfo/EcoDesign/escriculum/weather\\_data/weather\\_data\\_summ.html](http://web.utk.edu/~archinfo/EcoDesign/escriculum/weather_data/weather_data_summ.html)

Figure 8. Example weather bin data on psychrometric plots to frame climate profiles.

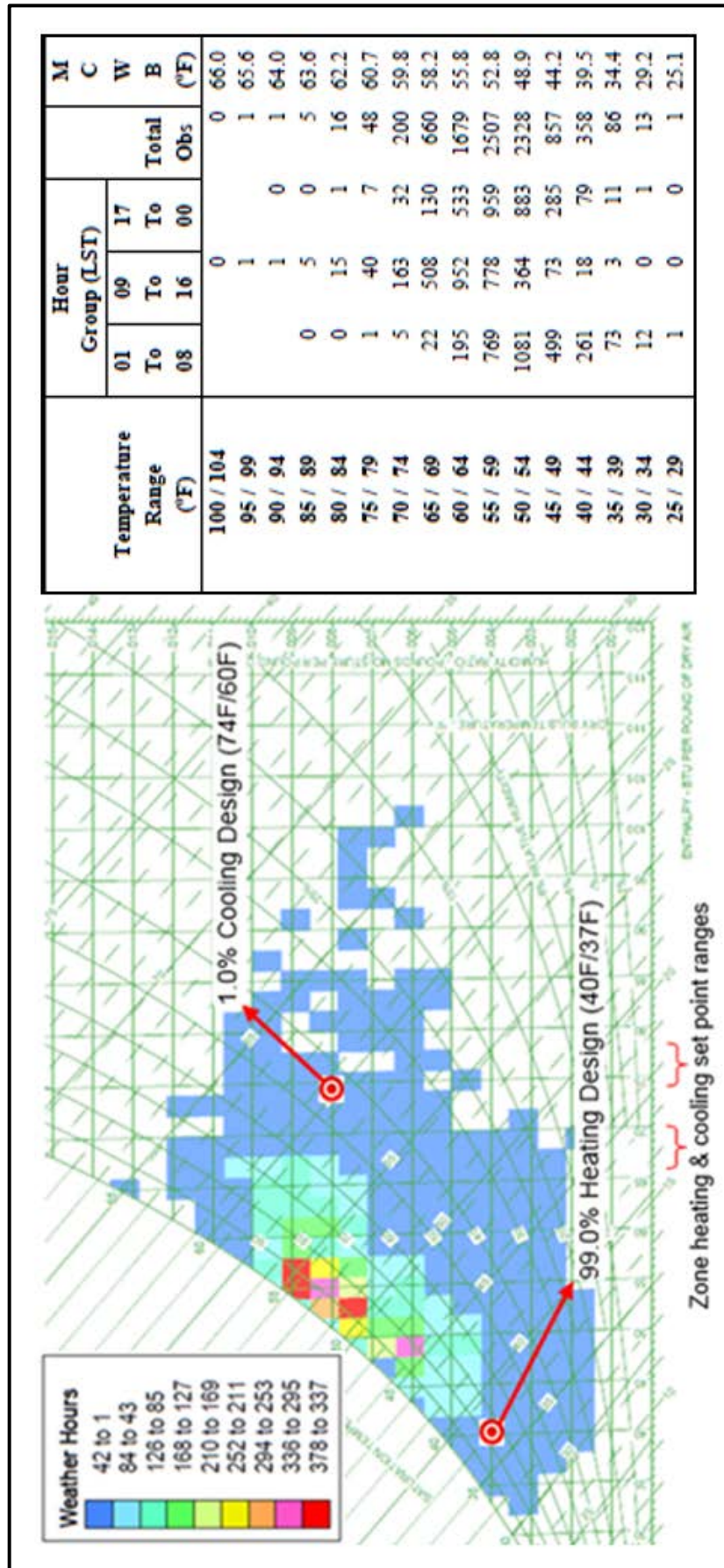
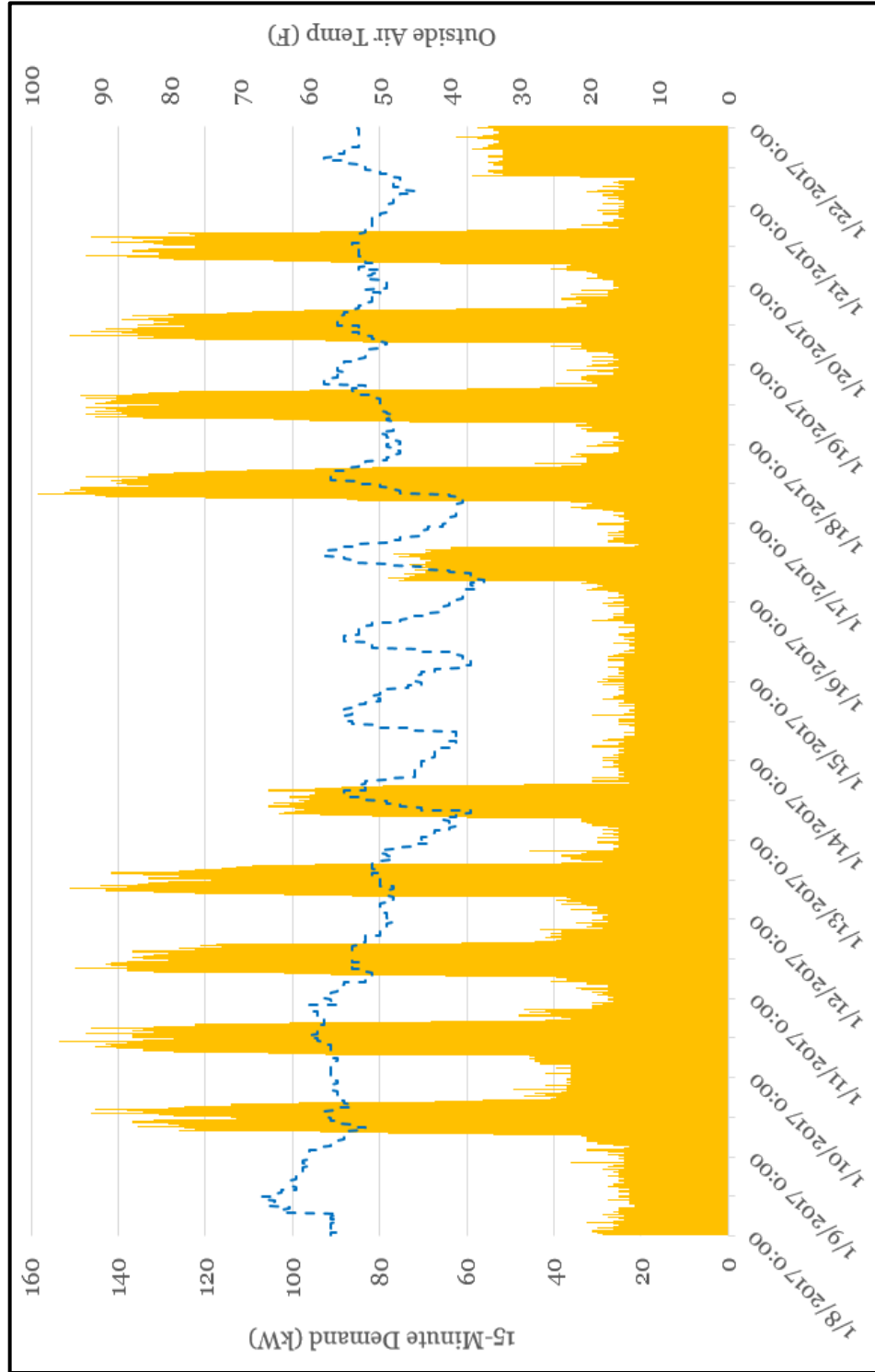

Figure 9. Interval utility data and weather information can reveal schedule-related patterns.



When available, interval data from Army, BAS, or utility meters may reveal issues and opportunities. Fine interval electric data (i.e., 15-minute data) will often show when buildings go occupied, start HVAC systems, use interior and exterior lighting, and stage central mechanical cooling. Even daily utility data, however, can quantify differences between weekend, holiday, peak, and part-load days and can reveal relationships between HVAC performance and daily temperature.

Since O&M service calls and preventative maintenance will typically be recorded in some central database, you may want to request these records (Table 7). In addition to learning how often O&M technicians are called out for specific occupant complaints, this information can be used as a baseline to check against any RCx implementation to ensure that changes are not overburdening O&M staff. Regardless, this optional step is no substitute for discussions on how systems are managed with O&M on-site.

Where occupant comfort issues are suspected, you may want to consider administering an occupant comfort survey before the on-site Assessment (Figure 10). The nature, timing, location, and frequency of occupant issues can shed light into how specific loads need addressing as well as act as a baseline against post-RCx changes. Online questionnaires are recommended for ease of creation, editing, distribution, and analysis. CERL maintains a collection of digital thermal comfort surveys to assist with this step.

**Table 7. Annual O&M work order data can be valuable in preparation for RCx Assessments.**

	O&M Service Request	Qty	Labor	Materials	Vehicle	Total
HVAC	Too hot/too cold reports	14	\$3,482	\$307	\$598	\$4,386
	Trouble call	8	\$1,431	\$30	\$320	\$1,781
	Thermostat (repair/replace)	3	\$1,544	\$0	\$120	\$1,664
	Service air handler systems	5	\$1,272	\$91	\$249	\$1,611
	Technical support	1	\$228	\$307	\$40	\$575
	Service Air-Conditioning units	2	\$256	\$0	\$80	\$336
	Duct work & air vent grill clean	1	\$171	\$0	\$40	\$211
	Gas line check/work required	1	\$48	\$0	\$40	\$87

Figure 10. Occupant surveys are optional RCx tools to better understand building usage.

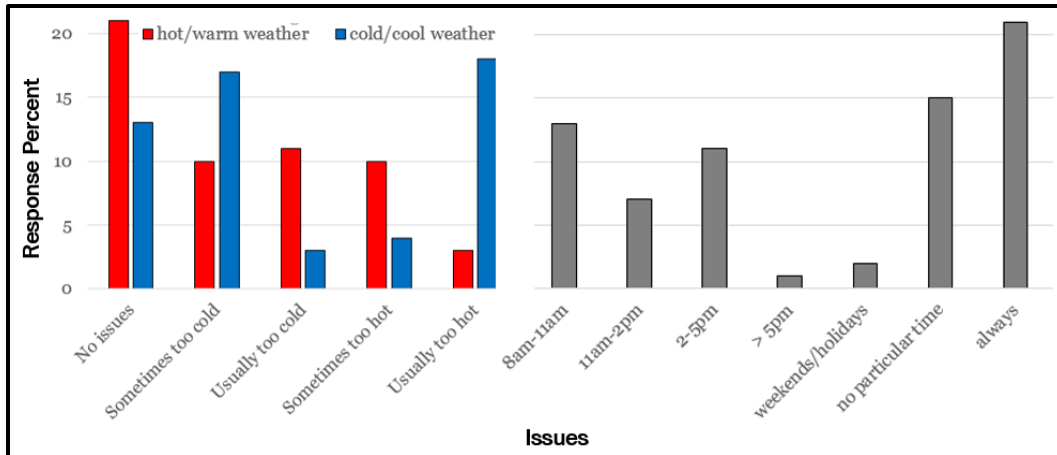

One additional best practice is the development of a Current Facilities Requirement (CFR). Similar to an Owner's Project Requirement (OPR) in construction projects, the CFR is intended to capture overall facility management goals. For RCx-purposes, this may include any of the following (see Chapter 10, "Resources List," for a CFR template):

- **Building Schedules:** Daily occupied and unoccupied schedules as well as exception (e.g., federal holidays) days for the building and/or individual spaces
- **Operational Setpoints:** Occupied and unoccupied (or standby) space temperature, humidity, or CO<sub>2</sub> setpoints and ranges
- **Goals:** Readiness or sustainability goals associated with the facility (e.g., target EUIs, redundancy, O&M trouble calls, etc.)
- **Controls Needs:** References or constraints related to specific sequence of operation (e.g., support or avoidance of certain setpoint reset strategies)
- **Space Modifications:** Any space configuration or criteria changes since design

## 5 Assessment

The goal of the on-site RCx Assessment is to record facility system conditions, identify obvious performance issues, and flag potential opportunities for more in-depth analysis in the RCx Investigation phase. A typical RCx Assessment (Figure 11) may take 1-3 days on-site (plus additional write-up and follow-up), but the amount of time needed and skillsets required will depend heavily on systems included and outcomes desired.

For each potential opportunity identified, consider and document what energy calculations, performance data, or functional test would help qualify or quantify your opportunity.

Another way to think about an RCx Assessment is as a “hands-in your pocket” walkthrough of mechanical spaces and zones to think about how the systems you are seeing are operating to meet occupant or process needs. There are several techniques, resources, and on-site staff that can help do this; however it starts with looking for obvious clues that systems are underperforming, mapping how key systems are configured and operating, and developing specific requirements to strategically guide follow-on Investigation tasks where required.

Figure 11. Steps and documentation for an RCx Assessment.

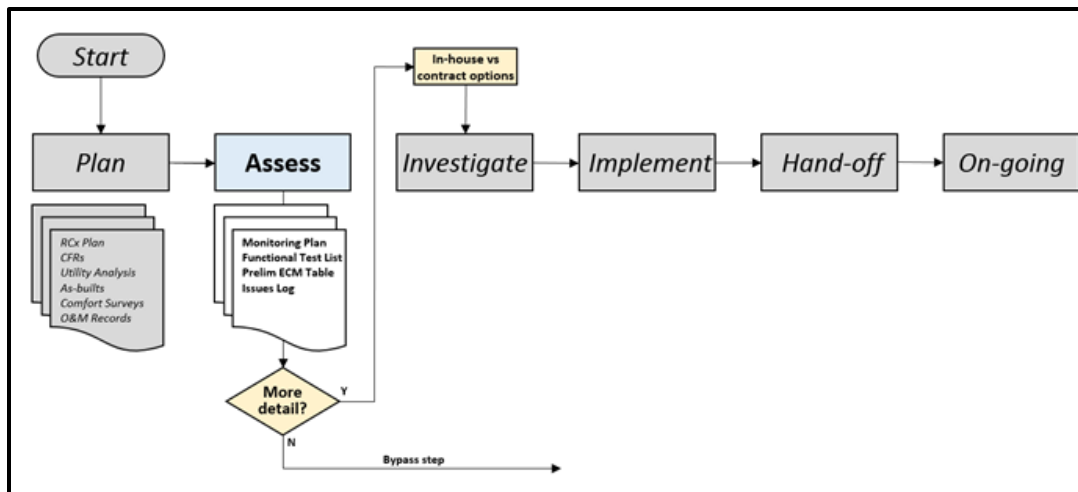

## 5.1 Typical RCx systems to assess

Any energy or water-using system may be evaluated during an RCx Assessment; however a focus on specific systems may be warranted based on planning phase findings or the recommendations of facilities management staff (Figure 12). Typically, HVAC and lighting systems with either overly simplistic or overly complicated control strategies make for the best Assessment candidates. Several system type examples worth considering with average energy use breakdowns from the Commercial Buildings Energy Consumption Survey (CBECS, 2009) (Figure 12) are:

- **Hot water or steam systems:** Hydronic or steam systems serving hot water heat exchangers to offset envelope losses, temper ventilation air, or reheat supply air typically via centralized gas-fired boilers though possibly in cogeneration or solar hot water configurations.
- **Chilled water systems:** Typically vapor compression chillers (though sometimes absorption or evaporative cooling) serving hydronic coils to space or ventilation loads.
- **Condenser water systems:** Where water-cooled chillers are employed, cooling towers and water-side economizer heat exchangers connected to chiller condenser barrels for heat rejection purposes.
- **Domestic Hot Water (DHW) systems:** Electric or gas-fired water heaters or boilers directly or indirectly heating and possibly storing potable water for showers, sinks, or cooking.
- **Pumping systems:** For all the above water-side systems, the pumping systems themselves can be RCx candidates to optimize flows, pressure-losses, and runtimes.
- **Air-side systems:** Various types of air handling units and their zone counterparts facilitate HVAC load management and ventilation across a spectrum of operating conditions.
- **Lighting systems:** Interior and exterior lighting systems provide space-specific lumen levels at various efficacies through a combination of switched, scheduled, or photocell controls.
- **Building Automation Systems (BAS):** The pneumatic, electric, or digital control systems themselves are comprised of different sensors, actuators, and interfaces that are often subject to error, communication issues, and improper setpoints.
- **Other systems** such as plug-load, plumbing, or renewable systems may be included in RCx Assessment as desired.

Figure 12. 2012 CBECS energy end use breakdowns for different facility types.

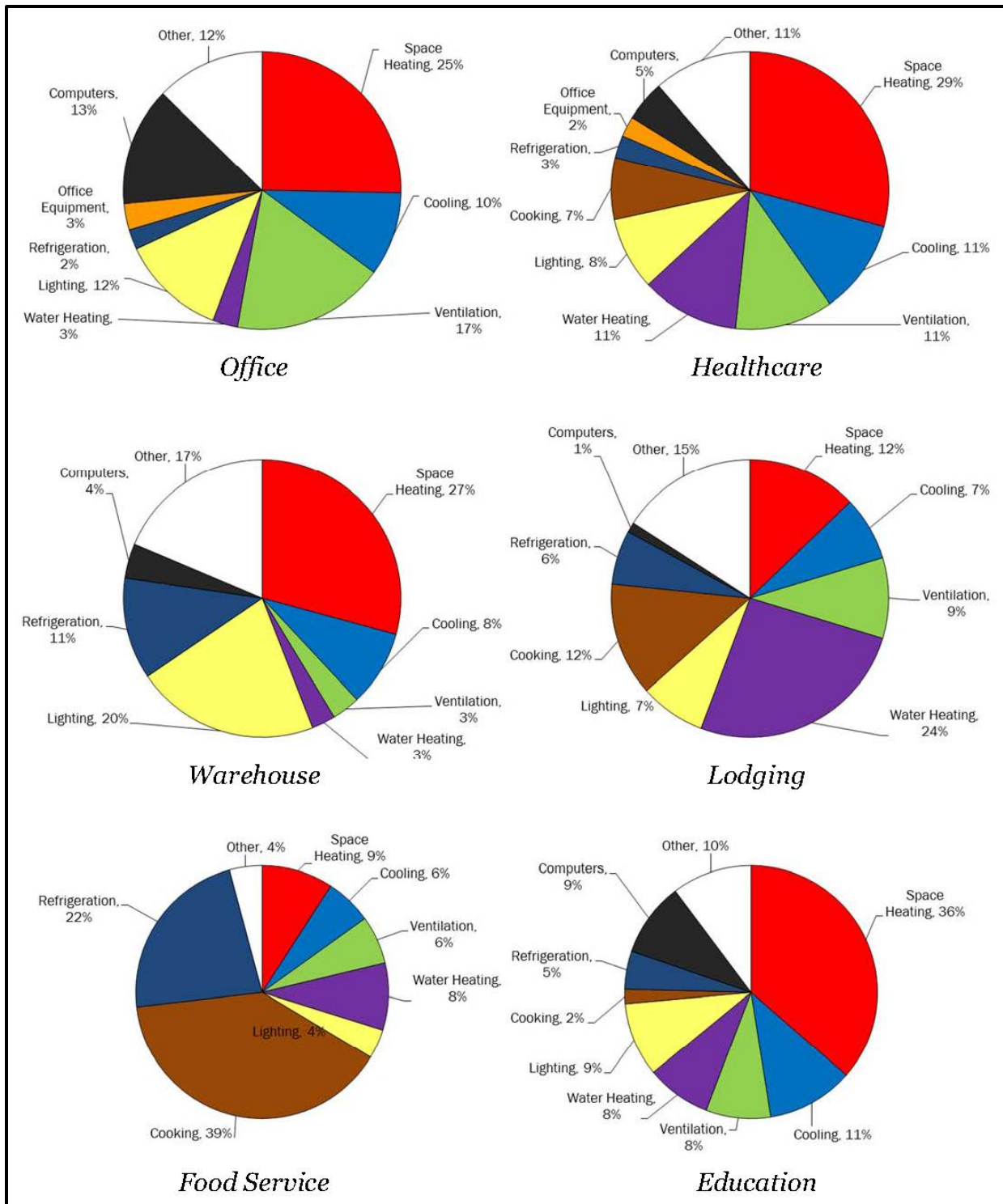

## 5.2 General assessment strategies

Start the RCx Assessment process by coordinating the on-site visit. Building management, O&M, and BAS representatives should be aware of your presence in their facility and what you are there to do. Be clear about your space and equipment access needs. Ideally, you can schedule times with each representative to document and address any known issues, operational nuances, and concerns with the RCx process.

When given the green light to start the Assessment, begin by walking around and then through the building, stopping at each representative space type and mechanical room. With permission, take pictures of major pieces of equipment for systems selected as well as any operational issues found (Figure 13).

In this initial walkthrough, be on the lookout for obvious indicators of performance. Note the issues found as well as any underlying problems or implications on utilities, O&M, or comfort they might suggest.

Record equipment nameplate data and observed system setpoints. Nameplate data may be needed to look up equipment capabilities later and setpoints can be found at the BAS front end, local BAS display panels, at some field controllers, or at equipment interfaces.

As a best practice, sketch field system diagrams to determine or validate how piped or ducted central systems are configured (Figure 14). System diagrams should be “untangled” to show a simplified arrangement of the major load management and controls equipment in the proper order of connection. These diagrams can be critical in recognizing and communicating improper system operation, monitoring needs, and opportunities for improvement. See Figure 14 and Chapter 10, “Resources List,” for system diagrams templates.

Figure 13. Examples of obvious indicators of performance: an Hand-Off-Auto (HOA) switch in hand mode may be accidental or indicative of a greater problem (top-left); active condensate drain may indicate unnecessary cooling (top-right); throttled pump discharge valve could mean oversized equipment (bottom-left); improperly installed sensors may be misleading control systems (bottom-right).



Figure 14. Example system diagram and library of symbols.

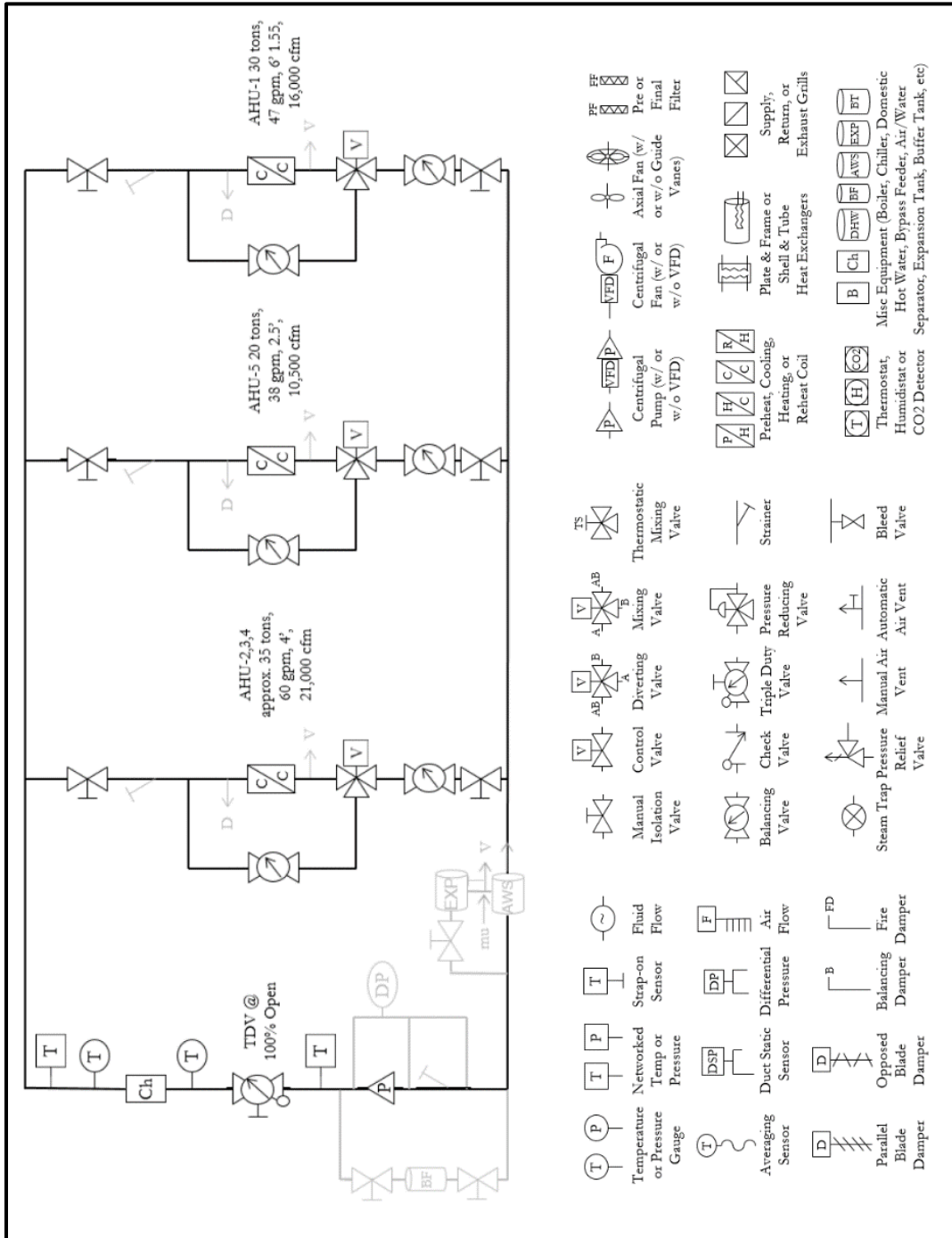

### 5.3 Specific assessment strategies

Throughout the RCx Assessment, you should be developing your list of potential energy conservation measures (ECMs). “ECM” is an industry standard term often used to describe other measures such as water conservation and O&M, comfort, or mission improvements. The emphasis should be on optimizing system performance in whatever way applies to your systems being assessed; however, for convenience, these ECMs can be categorized into a field checklist.

Although each facility will have its own energy use pattern, it is helpful to be aware of the common RCx measures that tend to produce the most impact in terms of energy savings. Table 8 lists the results of a study conducted for Lawrence Berkley National Laboratory that reviewed 122 RCx projects with more than 950 RCx measures. \* Almost half of the total savings opportunities identified result from three categories of measures: revision of control sequences, reduction in equipment runtime, and optimization of air-side economizers.

Table 8. Average energy savings impact of common RCx measures.

RCx Measure	Percentage of Total Savings
Revise control sequence	21%
Reduce equipment runtime	15%
Optimize airside economizer	12%
Add/optimize supply air temperature reset	8%
Add variable frequency drive to pump	6%
Reduce coil leakage	4%
Reduce/reset duct static pressure set point	4%
Add/optimize optimum start/stop	3%
Add/optimize condenser water supply temperature reset	2%

Sections 5.3.1 through 5.3.12 detail categories of ECMs. This more exhaustive list of possible RCx opportunities offers insight into the various ways building systems can be evaluated for optimization of energy, comfort, and O&M and can be used with the ECM Checklist in Chapter 10, “Resources List,” to aid in the RCx Assessment process.

\* <https://www.nrel.gov/docs/fy17osti/68572.pdf>

### 5.3.1 Scheduling

Since turning off entire systems sheds total runtime hours off equipment, scheduling opportunities continue to be some of the most attractive ECMs (Figure 15).

**Figure 15.** Scheduling opportunities are often readily implemented at low or no cost through front-end interfaces, field-level controllers, or simple timeclocks.

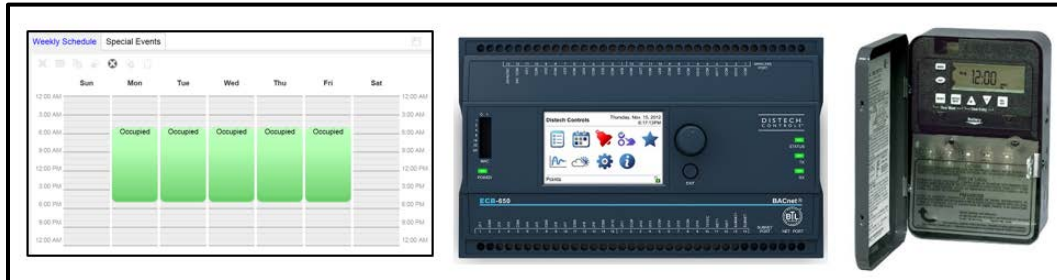

#### 5.3.1.1 Top ECM

Schedule trim (shaving operating hours off existing daily schedules).

#### 5.3.1.2 Other ECMs

HVAC exceptions (keeping systems off on holidays or other off days):

- Start-up/Shutdown optimization (automatic demand-based trim of start/stop hours)
- Zone scheduling (separate schedules for zone equipment with shorter occupied hours)
- DHW return pump scheduling (eliminating DHW recirculation losses when unused)\*
- Interior lighting circuit scheduling (automatic shutdown at known unoccupied periods)
- Exterior lighting circuit scheduling (automatic shutdown during middle of the night)
- Electrical equipment scheduling (ability to de-energize major circuits when unneeded).

#### 5.3.1.3 Clues

Has facility use changed since design? Are constant and/or lengthy warm-ups in place? Do spaces have a variety of operating hours? Are there known times of unused spaces or systems? Did a review of electric interval data in the Planning phase indicate a substantial amount of off-hours electrical load?

#### 5.3.1.4 O&M/Occupant Considerations

Make sure mechanisms exist for determining if occupants are negatively impacted by scheduling changes and allowing O&M staff to adjust schedules accordingly without the use of overrides.

\* ASHRAE Standard 12 Minimizing the Risk of Legionellosis Associated with Building Water Systems recommends a minimum return temperature of 124 °F in health-care and other high-risk situations.

### 5.3.2 Setpoint value adjustment

Often HVAC and lighting setpoints are not optimally configured or installed for a given system or space (Figure 16). What are the effects of operating outside of recommended setpoints? In the case of overventilation, providing more cubic feet per minute (CFM) than necessary per ASHRAE 62.1's ventilation rate procedure tables may be resulting in excess fan energy (to move extra air), excess cooling or heating energy (to condition more outside air), excess reheat energy (especially where low sensible loads are present) and excess pumping energy (to move extra chilled and hot water). Consider these effects and refer to setpoint guidance from ASHRAE, Illuminating Engineering Society of North America (IESNA), Army Regulation (AR) 420-1, or local Energy Design Guides (EDGs). Make sure you understand design intents before adjusting design setpoints.

Figure 16. Configurable direct digital control (DDC) zone controllers facilitate ease of many HVAC setpoint valve adjustments.

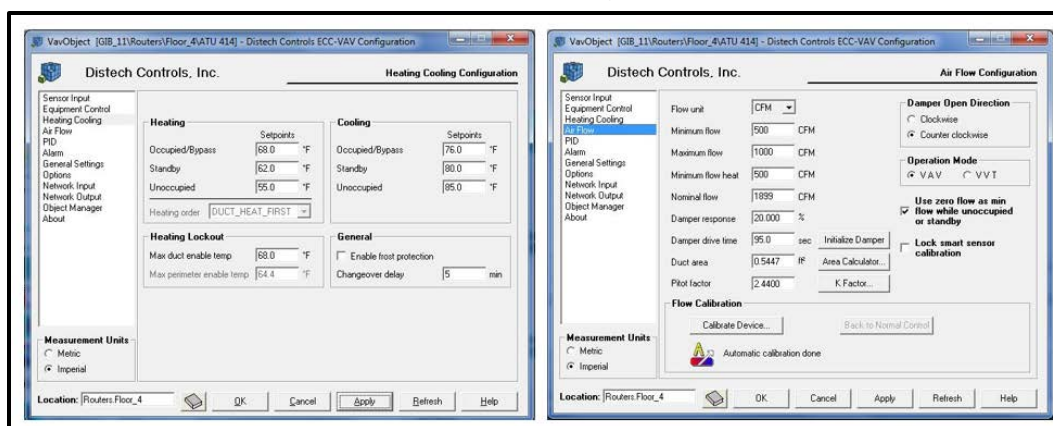

#### 5.3.2.1 Top ECM

Adjust zone CFM setpoints (instituting dual minimum zone CFM setpoints).

#### 5.3.2.2 Other ECMs

- Zone temperature setpoints (refer to AR 420-1 or local EDG)
- Adjust zone humidity or CO<sub>2</sub> setpoints (where low thresholds are overdriving HVAC)
- Adjust Mixed Air Temperature (MAT) setpoint (ensure that MAT control accounts for fan heat and coil enables)
- Adjust coil discharge setpoint (high latent design loads may not be present)
- Adjust hydronic supply setpoint (match supply temps to loads to limit distribution loss)
- Adjust duct static pressure setpoint (trend zone dampers during cooling to evaluate)
- Adjust lighting levels (delamp individual bulbs or retune dimmable ballasts).

#### 5.3.2.3 Clues

Are variable volume systems not varying? Are heating or cooling systems loaded off-season? Have primary building loads changed? Are temporary overrides in place?

#### 5.3.2.4 O&M/Occupant Considerations

Coordinate with O&M before removing overrides and understand implications to occupant indoor air quality/comfort before adjusting zone setpoints.

### 5.3.3 Automatic setpoint reset sequences

Where setpoints can be automatically adjusted by control systems or equipment to match dynamic load conditions, reset strategies should be considered (Figure 17). For every major HVAC or lighting application in your building, think about what key parameter (outside air temperature, valve or damper position, room occupancy, daylight levels, etc.) is responsible for influencing your load needs. How often would automatically adjusting setpoints, or resetting, away from design levels be possible (i.e., what is the load profile) and how much could be saved (i.e., what energy calculations apply)?

Figure 17. Most control systems and HVAC guidance (ASHRAE, Whole Building Design Guide [WBDG], etc.) support reset strategies.

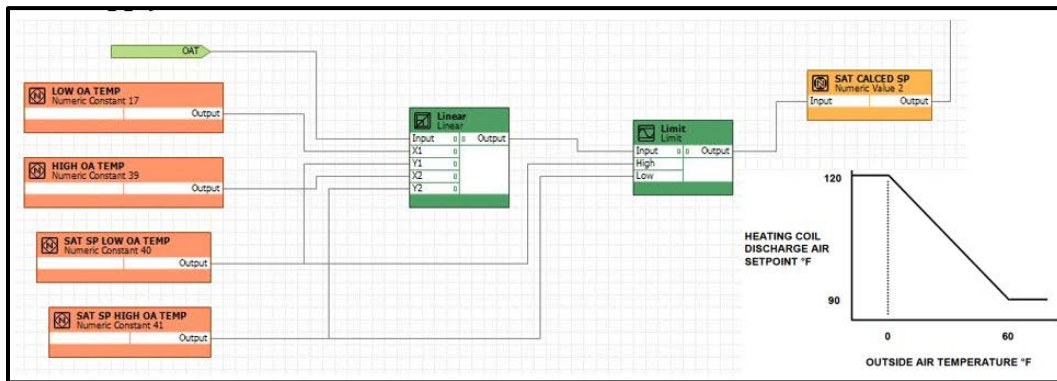

#### 5.3.3.1 Top ECM

Duct static pressure setpoint reset (vary setpoint off max zone damper %)

#### 5.3.3.2 Other ECMs

- Hydronic temp setpoint reset (vary setpoint off outside air [OA] or max valve %)
- Hydronic pressure setpoint reset (vary setpoint off pump or zone differential pressure)
- Hydronic storage temp setpoint reset (vary setpoint off solar irradiance available)
- Supply air temp setpoint reset (vary setpoint off OA, valve %, or zone temp deviation)
- Mixed air temp setpoint reset (vary setpoint off OA or to follow Supply Air Temperature [SAT] reset)
- Min OA economizer flow setpoint reset (vary setpoint off zone CO<sub>2</sub> resets)
- Zone CFM setpoint reset (vary setpoint off zone CO<sub>2</sub>)
- Zone temp/humidity setback (vary setpoint off schedule, timer, or push button)
- Low-use equipment standby (ensure that Energy Star or related settings are enabled)
- Dimmable lighting (vary setpoint of fixtures off daylight sensors).

#### 5.3.3.3 Clues

Are modern control systems installed? Do loads vary over time or based on some monitored metric? Does the building benchmark well, but have underused controls?

#### 5.3.3.4 O&M/Occupant Considerations

Properly implemented setpoint reset strategies should not impact occupants but may require periodic O&M checks (e.g., rogue zones).

### 5.3.4 No-load disables

As loads drop off or the need for systems subsides, disabling equipment is a major energy conservation opportunity. This can be done through scheduling (where no-load periods are known) or conditional logic (where no-load recognition can be automated). Consider putting air-side equipment for partial use (e.g., conference) spaces on standby mode with push-button override. Disable heating equipment and associated pumps when outdoor air temperatures exceed the building's balance point and limited calls for reheat (Figure 18). Cooling system lockouts may be better configured off sufficiently closed coil valves or lack of zone cooling requests. Most interior and exterior lighting can also be scheduled, time, or motion-activated.

**Figure 18. Air-side, heating, and cooling systems may be good candidates for no-load disables.**



#### 5.3.4.1 Top ECM

Outside air boiler/chiller lockout (disable off OA max/min threshold).

#### 5.3.4.2 Other ECMs

- Valve-based boiler/chiller lockout (disable off threshold of valve %)
- Time delay hydronic pump disable (time delay shutoff with boiler/chiller lockouts)
- HVAC equipment standby/override only (demand-based enables and setpoint drift)
- HVAC occupancy sensors (link zone HVAC enables to motion with time delays)
- Lighting occupancy sensors or timers (link interior lighting to motion with time delays)
- Exterior lighting motion sensors, timers, or schedules (demand-based exterior lights)
- Electrical equipment demand-only (shutoff switch or timer for specialized equipment).

#### 5.3.4.3 Clues

Does HVAC run when no load or need is evident? Do lighting systems lack two levels of control? Is specialized equipment used intermittently (e.g., laboratory exhaust, sauna heaters, clinic equipment, etc.)?

#### 5.3.4.4 O&M/Occupant Considerations

Coordinate with occupants, O&M, and other important stakeholders (safety manager, security officer, etc.) to ensure that disables are feasible.

### 5.3.5 Oversized equipment

Equipment oversizing can take many shapes. Load management equipment (e.g., boilers, chillers, etc.) may or may not be oversized in their total capacity (for example, see Figure 19); however the lack of adequate turndown or staging necessary to regularly meet part-load conditions may have detrimental effects on energy performance and equipment longevity. Centrifugal fan and pumping systems, designed under assumed pressure conditions, may produce excess flow or be inefficiently balanced with cubic-law implications on power consumption. Also, lighting systems may be so grossly overlit that fixture or technology replacement may be justified.

**Figure 19. Pump discharge valves offer clues into oversized equipment opportunities.**



#### 5.3.5.1 Top ECM

Pump optimization (trim impeller, install a variable frequency drive [VFD], or replace pump/motor).

#### 5.3.5.2 Other ECMs

- Fan resheave (replace fan or fan pulley to match needs)
- Thermal flywheel or buffer tank (reduce equipment cycling via hydronic capacitance)
- Boiler/chiller resizing (as part of O&M repair, trend loads and right-size equipment)
- Reduce lighting via fixture/bulb replacement (when delamping is not feasible/desirable).

#### 5.3.5.3 Clues

Have HVAC loads, infrastructure, or zoning been altered from design? Do loads swing dramatically? Does equipment regularly trip or visibly short-cycle? Are boilers high-low fire only, chillers using hot gas bypass, pump discharges noticeably throttled?

#### 5.3.5.4 O&M/Occupant Considerations

Discuss resizing or size mitigation strategies with O&M before changes. No occupant comfort issues should be expected.

### 5.3.6 Load reduction

Unnecessary loads should be eliminated or reduced wherever possible. A common opportunity here is with simultaneous heating and cooling, which is sometimes by design (multi-zone units, dual duct systems, and variable air volume [VAV] reheat configurations) and other times hidden in operations (failed coil valves or dampers, conflicting HVAC sequences of operation or setpoints [see Figure 20]). Unnecessary pressure drops in hydronic or air-side systems as discharge dampers, throttled valves, poor fittings, superfluous coils, and disconnected or failed ductwork represent unnecessary loads on pumps and fans. Also consider envelope improvements (failed insulation/seals, or regularly open doors/windows) and removing unneeded electronics (unused IT switches, refrigerators, or process equipment/workstations).

Figure 20. HVAC problems are often hidden (failed economizer and simultaneous heating/cooling shown).

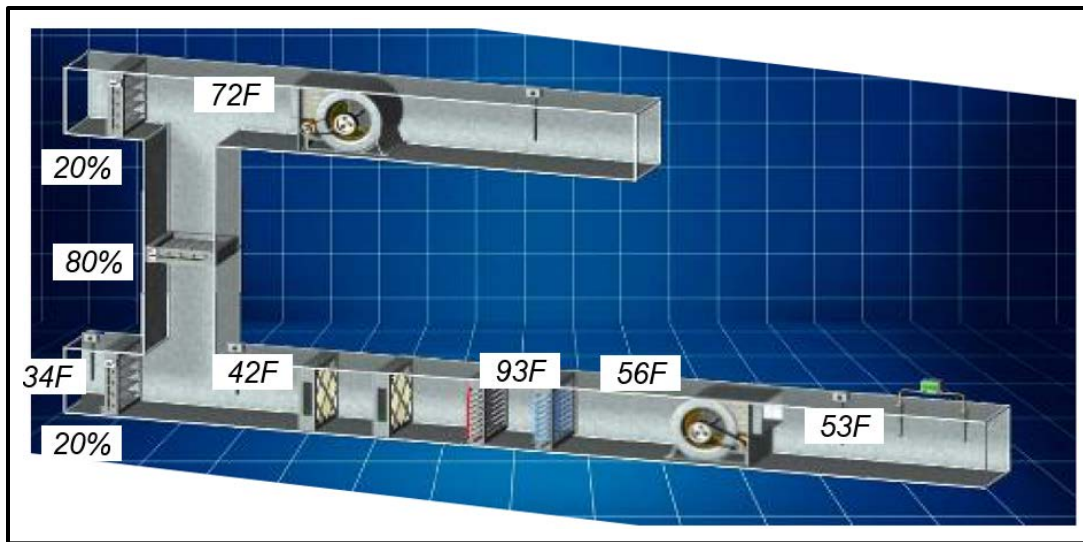

#### 5.3.6.1 Top ECM

Simultaneous heating and cooling mitigation (reprogram or repair to limit)

#### 5.3.6.2 Other ECMs:

- Remove air-side pressure drop (eliminate for square-law fan savings)
- Remove water-side pressure drop (eliminate for square-law pump savings)
- Envelope entry improvements (spot repairs on critical air or thermal barriers)
- Decommission unused electronic equipment (disconnect extra/forgotten devices).

#### 5.3.6.3 Clues

Are heating and cooling systems operating together? Do air handling unit (AHU) setpoints conflict? Do fans and pumps run high? Have conversions to variable volume left pressure drops in the system? Could envelope loads or process equipment be major energy drivers?

#### 5.3.6.4 O&M/Occupant Considerations

Coordinate any equipment removal.

### 5.3.7 Variable volume

System configuration conversions may be justified, especially where VFDs can be expected to ramp air or water-side flows down from design conditions based on some driving performance parameter (easiest in single zone applications). Although VFDs may represent a slight overall efficiency drop in the system (1-3% from electronics losses), they can leverage centrifugal device affinity laws for cube-law savings between motor shaft speed and brake horsepower while preserving the original pump or fan efficiency (Figure 21). Drive pump speed to maintain a set terminal unit differential pressure and fan speed to maintain the duct static pressure (DSP) setpoint as measured two-thirds of total distribution length.

**Figure 21. Most fan and pump motor systems can be readily retrofit for VFD applications.**



#### 5.3.7.1 Top ECM

Constant to VAV AHU retrofit (with VFD, DSP sensor, possibly dampers).

#### 5.3.7.2 Other ECMs

- Multi-zone or dual duct to VAV retrofit (with separate or max actuators)
- Optimize return/relief fan (flow offset for return, cooling-only or zone control for relief)
- VAV exhaust/flow hoods (flow offset for exhaust, on-demand or sash control for hoods)
- Variable hydronic (speed control off pump or distant terminal unit differential pressure)
- Variable hydronic (speed control off OA conditions or valve positions)
- Primary-secondary reconfiguration (replace or remove improper bypass piping)

#### 5.3.7.3 Clues

Are air-side systems single zone, multiple zones with good box retrofit access, multi-zone or dual duct, or using inlet guide vanes? Are hydronic systems using only a small number of three-way valves? Are plant bypasses relatively short and fat piping?

#### 5.3.7.4 O&M/Occupant Considerations

Communicate retrofit intent and needs with O&M.

### 5.3.8 Equipment efficiency

Leveraging existing equipment or equipment mode efficiencies is an ideal RCx opportunity, and replacing or scheduling an as-fails replacement of components with higher efficiency counterparts is often justified (Figure 22). Make/model information from nameplates will provide an indication of efficiency *capabilities*; however whether units are operating at stated efficiencies may be dependent on other factors. Condensing boilers, for instance, only reach condensing-level combustion efficiencies when entering water is below the flue gas dew point. Chiller kW/ton values also vary for different outside air temps, water temp deltas, and part-load conditions.

Figure 22. Select high nominal efficiencies in use, but focus on overall system efficiency.



#### 5.3.8.1 Top ECM

Maximize condensing boiler operations (reset supply temps below 140 °F)

#### 5.3.8.2 Other ECMs

Drive upgrades (minimize motor, pump, fan, VFD, or belt losses).

- Optimized equipment staging (leverage modular fans/burners, avoid hot gas bypass use)
- Zone-level 1st stage HVAC (leverage local load management before plant demand)
- Economizers: (improve high/low-limit lockouts, damper types, or closure modes)
- DHW heater: (retrofit to condensing/instant/timed or switch utility type)
- Lighting bulb type retrofit (technology upgrades to Light Emitting Diode [LED] bi-level or comparable).

#### 5.3.8.3 Clues

Are devices high efficiency and operating near peak efficiency? Do resets and staging leverage performance curves? Are O&M equipment replacements approaching?

#### 5.3.8.4 O&M/Occupant Considerations

Prepare improved specs on higher efficiency units needed to avoid replace-in-kind reactions to abrupt equipment failures.

### 5.3.9 BAS repairs

The BAS, also referred to as the Utility Monitoring and Control System (UMCS), is a set of subsystems critical to properly functioning facilities (Figure 23). Ideally, the BAS is centrally operating, network accredited, and staffed/supported/used by key installation staff. Validate UMCS connectivity and adequate interface to programming, configuration, backup, trending, scheduling, alarming, and graphics features (see BAS Checklist in Chapter 10, “Resources List”) before assessing for specific sequence, instrumentation, or controller problems. Healthy BAS will better facilitate RCx ECM opportunities, implementation, and M&V.

Figure 23. Modern BAS is comprised of many graphical interfaces, engineering tools, software plug-ins.

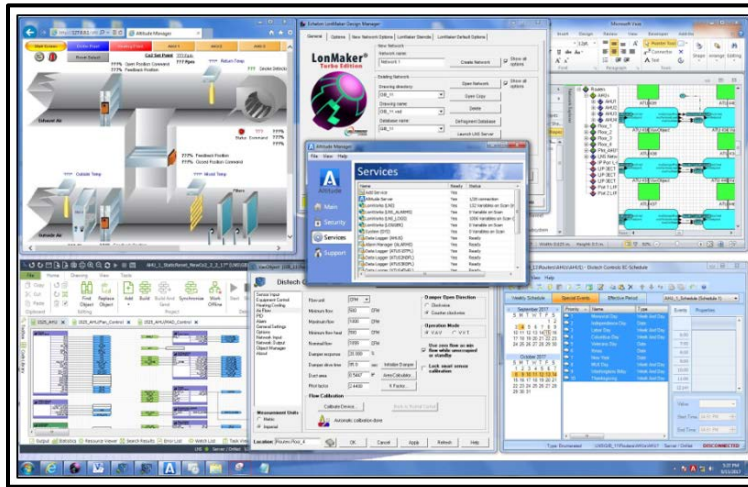

#### 5.3.9.1 Top ECM

Correct communication errors (re-enable/reissue/recommission/replace).

#### 5.3.9.2 Other ECMs

- Correct controller logic or configuration errors (fix sequences or settings)
- Calibrate sensors (test/adjust suspect temp, pressure, motion, or CO<sub>2</sub> instrumentation)
- Relocate/replace sensors (ensure that measurement captures real-time performance drivers)
- Repair actuators: damper, valve, or relay (failure-prone electro-mechanical devices)
- Control loop tuning (principal investigator [PI] response with limited overshoot, steady-state error, and cycling)
- BAS replacements or upgrades (use vendor-supported hardware and updated software).

#### 5.3.9.3 Clues

Are BAS features missing, misunderstood, unsupported, underused, overly proprietary, or new to O&M staff? Are there scheduling or sequence anomalies?

#### 5.3.9.4 O&M/Occupant Considerations

Provide resources for long-term BAS support (manuals, training, vendor Point of Contacts [POCs], Standing Operating Procedure [SOPs]). Ensure that safeties are working before loop tuning.

### 5.3.10 O&M processes

There can be significant challenges to optimally running a building. Funding/staffing shortfalls, employee turnover, demanding skillsets, contractual interpretations, and emergency distractions can all conspire to limit the effectiveness of an O&M program. The RCx process is intended to aid O&M technicians by taking the time to explore the problems they do not have time to identify or fully investigate. Be on the lookout for deferred maintenance, failed or failing equipment conditions, overuse of overrides, and non-ideal preventative maintenance or unit replacement processes.

#### 5.3.10.1 Top ECM

Equipment repair (issue work orders for failed components including broken economizer damper actuators, leaking hydronic valves, faulty sensors, and spot lighting/envelope fixes)

#### 5.3.10.2 Other ECMs

- Equipment/controller HOA or DDC overrides
- Filter replacements (optimize replacements to balance fan energy vs. purchase costs)
- Equipment tuning/treatment/blowdown (address preventative maintenance issues)
- Low-cost no-cost strategies (develop approaches for self-directed improvements)
- Gaps in staffing, training, or workflow (identify O&M needs affecting performance)

#### 5.3.10.3 Clues

What pressing or recurring issues do techs face? Is deferred maintenance limiting performance? Are overrides masking larger problems? Are complaints driving O&M? See Figure 24.

#### 5.3.10.4 O&M/Occupant Considerations

Help O&M develop proactive rather than reactive strategies and ensure that ECM implementation will not overburden staff or disturb occupants.

**Figure 24. Test unit efficiencies, note overrides, discuss replacements, and identify failed parts.**



### 5.3.11 Human behavior and occupant comfort

The occupants of a building are part of its operation and often integral to its performance (Figure 25). The influence occupants can have on a system must be accounted for and can often be leveraged to trim equipment schedules, institute on-demand usage modes, or limit process-based energy consumption. Signage and leadership buy-in can be key for conveying what the expectations are for occupant involvement in building systems. Label any HVAC or lighting controls that occupants are anticipated or expected to interface with. Consider surveying occupants for their comfort problems (see template in Chapter 10, “Resources List”) and helping to institute conservation incentives.

Figure 25. Help occupants understand thermostat and zoning information with instructional signage.

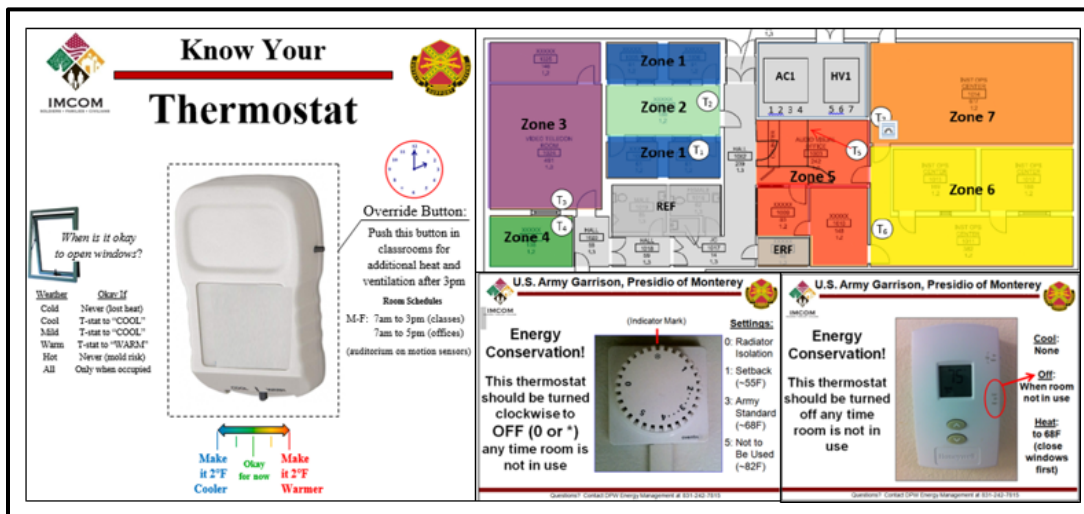

#### 5.3.11.1 ECMS

- Inadequate signage or instruction (develop labeled instructions for occupants)
- Occupant start-up/shutdown procedures (develop lights/HVAC walkthrough SOP)
- Occupant bypass of facility systems (zone/off options in lieu of central HVAC/lighting)
- Missing HVAC/lighting override capabilities (manual enable button/timer for off-hours)
- Energy conservation incentives (Building Energy Monitor, mock bills, award programs)
- Thermal comfort complaints (address complaints from occupant or O&M surveys)

#### 5.3.11.2 Clues

How satisfied are occupants with their systems? Does dissatisfaction follow any patterns in zone, time, day, or season? Is demand-controlled ventilation supported?

#### 5.3.11.3 O&M/Occupant Considerations

Keep occupants and O&M involved in any new sequences or involvement needed. Occupant-enabled demand-controlled ventilation (DCV) requires strategic coordination.

### 5.3.12 Water savings

While energy usage and costs savings are typically the primary focus in RCx applications, optimizing additional systems and pursuing other utility reductions may be desired (Figure 26). Plumbing systems, for example, may house opportunities for water conservation. Consider if water billing data aligns with expectations on usage profiles given facility size, function, and occupancy. Leaks may be present outside the building, HVAC equipment may be unnecessarily using makeup water, heavy irrigation may be in use, non-potable water usage may be possible or improved, and equipment or processes may benefit from reduced flow retrofits (e.g., WaterSense devices).

Figure 26. Optimize existing domestic, cooking, irrigation, and non-potable water flows.



#### 5.3.12.1 ECMs

- Utility leak detection (utility company notification/support for service leaks)
- HVAC makeup water tracking (metering or otherwise monitoring plant makeup flows)
- Irrigation improvements (rescheduling, limiting, or eliminating landscape watering)
- Optimize non-potable water flows (ensuing non-potable storage is maximized/favored)
- Mitigate evaporative cooling water losses (vendor-specific treatment/blowdown values)
- Equipment/process improvements (low-flow nozzles, equipment, and processes).

#### 5.3.12.2 Clues

Do water bills make sense? Are showers, cooking systems, irrigation, evaporative cooling, or other big water users present? Can non-potable systems be better used?

#### 5.3.12.3 O&M/Occupant Considerations

For process improvements such as a commercial dishwasher replacement, ensure that user needs are met. Make use of any installation Water Management Plans. Pursue leadership buy-in for any changes to irrigation systems.

## 5.4 Assessment phase deliverables

The RCx Assessment phase is completed when selected systems have been assessed and the appropriate documentation developed. In some cases there may be no justification for a more detailed Investigation phase (e.g., little opportunity is discovered, changes are made immediately, or ECMs can proceed directly to Implementation phase). Often, however, some level of follow-on Investigation is required to better understand or quantify potential ECMs and the following documentation can aid in effectively performing or contracting this work. See Chapter 10, “Resources List,” for current downloadable templates on the below deliverables.

### 5.4.1 RCx findings list

During the RCx Assessment, the growing number of possible RCx opportunities observed or suspected should be recorded in an RCx Findings List. Record the following information:

- numbered findings by system
- brief description of the nature and details of each finding
- type of opportunity (energy/demand/gas/water savings or O&M/comfort improvement)
- notes section for additional information or reminders.

### 5.4.2 ECM checklist

Optionally, use an ECM Checklist like the one listed in Chapter 10, “Resources List,” to record the opportunities that are possible, that may be likely, or that appear to have problems. This resource is based on the ECM breakdown Section 5.3, “Specific assessment strategies,” and may be beneficial for planning an RCx Assessment or to brainstorm possible opportunities that may apply during the Assessment. The ECM Checklist, however, should be secondary to the more open-ended RCx Findings List where tailored opportunities can be described. Note that CERL maintains a library of RCx Assessment field sheets and other RCx templates and resources (Figure 27).



#### 5.4.4 Monitoring plan

The Monitoring Plan is intended to answer the question, “*How could I capture system performance data that would tell me what I need to know about a potential RCx finding?*” Building a Monitoring Plan is thus a crucial RCx skill to facilitate later data logging or trending. Whether this document is used to track in-house deployment and collection of portable data loggers and BAS trends, or instead serves as the basis for contractor bids to strategically execute the Monitoring Plan, organization is key. The following information should be included in the initial creation of the Monitoring Plan and updated during its execution:

- ECM, system, and location for each desired performance metric
- Type of monitoring (BAS trends vs. data logger)
- Identification (ID) (either BAS point name or portable logger tag information)
- Trend length and interval required (specific to each metric)
- Dates associated with launching loggers or configuring trends and collecting the data
- Status (launched, installed, lost, broken, collected, etc.)
- Additional notes (e.g., logger port used, location hints, references).

#### 5.4.5 Functional test list

During the assessment, you may determine that certain functional tests are required to further diagnose system opportunities. Functional tests look at system response to some natural or forced change. There are a wide range of potential tests, including economizer mode checks, duct traverses, pump tests, equipment start-ups, thermal flywheel cycle tests, and many others. These tasks also represent later in-house work or a set of performance-based deliverables for a contractor to provide. In either case, be clear what documentation is necessary and consider the following sections to any needed functional test:

- Purpose (what ECM or issue the test is seeking answers or information on)
- Equipment/references required (special instrumentation, tools, field sheets, and engineering or manufacturer data needed)
- Acceptance criteria (what constitutes a complete/successful test)
- Precautions/prerequisites/preparation (pre-test considerations and tasks required before initiating the test)

- Roles and responsibilities (who does what during the test including emergency support that may be needed)
- Procedures (step-by-step list of actions and readings for the test)
- Return to normal and follow-up (steps to get the system back to previous operation and what needs to be done with the information collected).

#### **5.4.6 Preliminary ECM table**

Ideally, a clean summary of the above information can be developed into a Preliminary ECM Table that indicates for each ECM:

- Numbered ECMs with applicable system and summary title
- Rough order magnitude of utility savings, cost savings, and implementation costs (or high-low ranges)
- Whether the ECM is included in Monitoring Plan or Functional Test requirements
- Status (implemented, recommended, low priority, etc.).

### **5.5 RCx investigation candidates**

The next step in the RCx process is to determine whether an RCx Assessment should be followed up with a more detailed RCx Investigation. In some cases, ECMs may be either limited in number or complexity, sufficiently understood, or largely implemented during the RCx Assessment such that a subsequent RCx Investigation may be deemed unnecessary. Criteria for continuing on to the RCx Investigation phase may be organization-specific; however examples of good RCx Investigation candidates include:

- Relatively large, complex, or energy intensive facilities where additional ECMs can be expected
- Facilities where insufficient documentation, inoperable equipment, or faulty automation systems prevented the assessment of targeted systems
- Instances where trending, testing, or additional use of automation systems is required to better determine the nature of issues and opportunities identified
- Projects where performance data is needed for capital improvement scope development, utility incentive validation, or replacement equipment sizing.

## 6 Investigation

The intent of the Investigation phase (Figure 28) is to perform detailed testing and analysis of specific existing systems, reveal operational characteristics, verify the need for changes, and quantify the implementation needed and benefits expected. This is the tool and data intensive portion of RCx and may be most appropriate for contracting to RCx specialists. Chapter 10, “Resources List,” references tools to aid in effective acquisition of RCx services, including template RCx scopes of work by phase, contractor evaluation form, and example reports.

Ultimately, Assessment results drive Investigation tasks, which in turn drive Implementation actions. Real world RCx applications can be less linear than this; since new discoveries may require additional looks at benchmarking, scoping, or trending steps, it is important to try to distinguish between what is *interesting* and what is *important*. With limited time and manpower, Investigation phase tasks should focus on correcting or improving system performance based on key energy metrics collected.

If you plan to contract for these services, consider targeting specific entities that may better address your specific list of ECMs. For instance, an Energy Services Contractor (ESCO) may be a good fit to oversee the testing and analysis of a variety of ECMs, but for a controls-specific package of ECMs, a local vendor or PNNL’s Retuning Program may be a better choice.

Figure 28. Steps and documentation for an RCx Investigation.

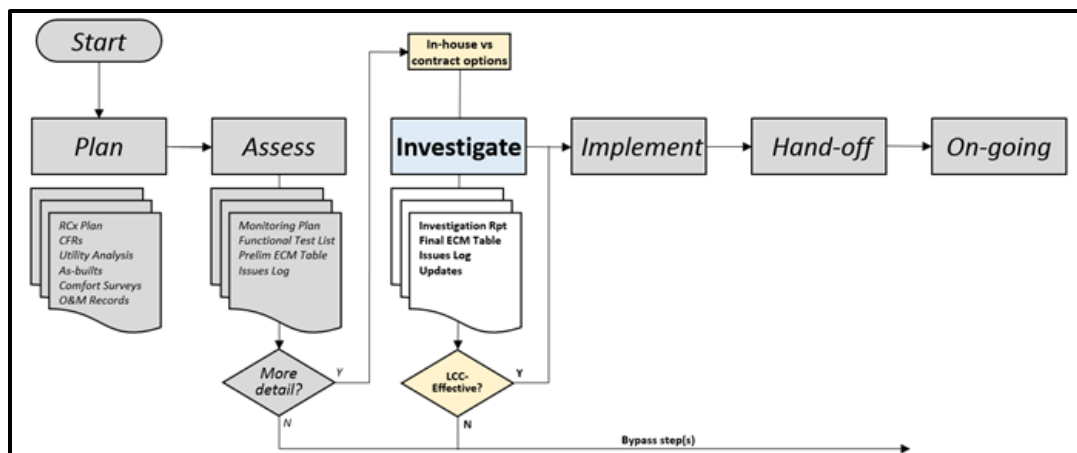

## 6.1 RCx instrumentation requirements

The on-site portion of the RCx Investigation phase demands adequate tools to collect the performance and response data necessary to understand and optimize system performance. Table 9 lists NEBB Procedural Standards for Retro-commissioning Instrumentation Requirements (2009). Whether building an RCx tool library or contracting RCx services, consider the listed standards as guidelines when determining the acceptability for different field measurements.

**Table 9. Recommended RCx instrumentation range, accuracy, resolution, and calibration.\***

Function	Minimum Range	Accuracy	Resolution	Calibration Interval
Temperature Measurement	-40 to 150 °F	± 1%	0.2 °F	12 months
Humidity Measurement	10 to 90% RH**	2.5% RH	1%	12 months
Air Velocity Measurement	50 to 2500 fpm	± 5%	20 fpm	12 months
Air Pressure Measurement	0 to 6 in. w.c.	± 2%	0.1" w.c.	12 months
Pitot Tube Measurement	minimum length for application	N/A***	N/A	N/A
Air Flow (Hood) Measurement	100 to 2000 cfm	± 5% and ± 5 cfm	1 cfm	12 months
Water Pressure Measurement	0 to 100 ft. w.c.	± 2%	1.0 ft. w.c.	12 months
Moisture Measurement	0 - 100%	± 5%	1.25" Penetration	per mfr.
CO <sub>2</sub> Measurement	0 to 2500 ppm	± 50 ppm	1 ppm	12 months
CO Measurement	0 to 2000 ppm	± 5 ppm	1 ppm	12 months
Rotation Measurement	0 to 5000 rpm	± 2%	± 5 rpm	12 months
Electrical Measurement	0 to 600 VAC <sup>‡</sup> and 0 to 100 Amps	± 2%	1.0 Volt and 0.5 Ampere	12 months
Light Level Measurement	0 to 3000 fc	± 10 fc	2 fc	12 months
Infrared Thermometer/Camera	-4° - 500° F	± 2%	±0.1° F	per mfr.
Digital Camera	24 mm - 72 mm	3 x Zoom	3.1 mega pixels	per mfr.
<p>* Data logger calibration may be verified from a calibrated instrument  ** Relative Humidity (RH)  *** Not Applicable (N/A)  <sup>‡</sup> Volt AC (VAC)</p>				

## 6.2 Monitoring plan execution

Someone must execute the Monitoring Plan by collecting the data as indicated. There are a number of possible sources available for facility data:

- Interval utility data may be available from privatized, BAS, or Army advanced meters.
- Weather information (weather station conditions, heating/cooling degree data, binned temperatures) can be found online through *Wunderground* (<https://www.wunderground.com/>) or the National Climate Data Center (<https://www7.ncdc.noaa.gov/CDO/cdopoemain.cmd?datasetabbv=DS3505&countryabbv=&georegionabbv=&resolution=40>).
- The most rich set of building data may be available from existing BAS trends logs, especially where zone points are setup; however network traffic may limit extensive fine interval trending, and integrity of point data is dependent on instrumentation type, location, and calibration.
- As an alternative or supplement to BAS trends, battery-powered portable data loggers (Figure 29) can meet virtually any facility logging need and are often used to execute RCx Monitoring Plans.

Figure 29. Typical data logger devices for RCx applications.

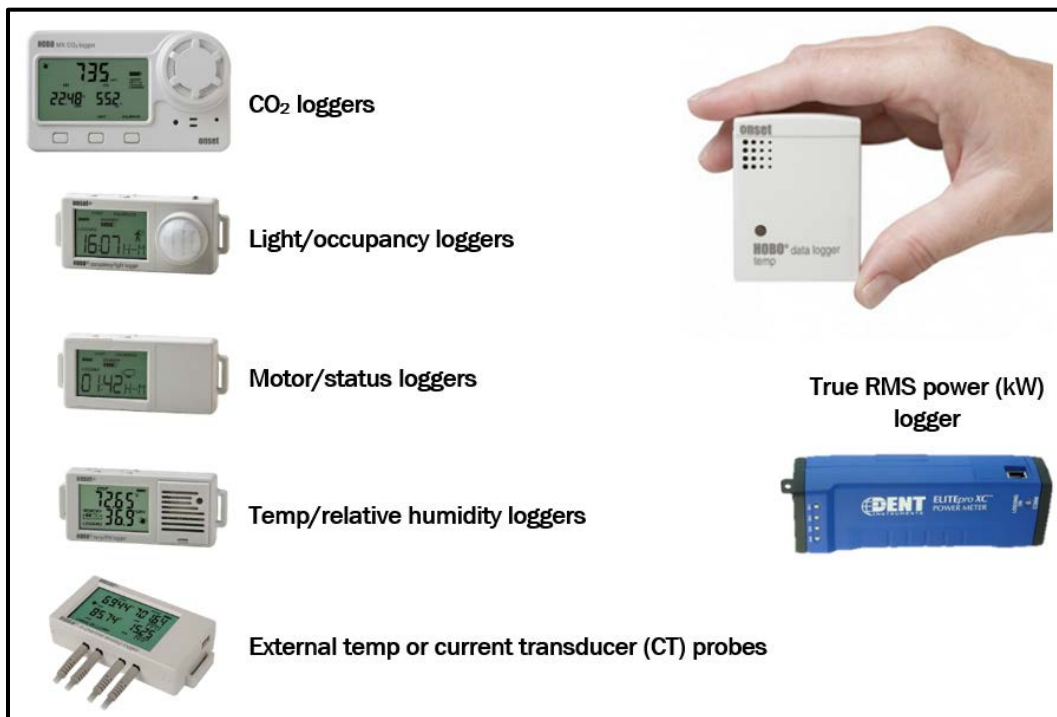

### 6.3 Functional testing

More extensive tools (Figure 30) and coordination may be needed for functional performance testing (for example, see Figure 31). Functional testing, which often asks “*what happens when I do this...*,” can be inherently more obtrusive than data logging, but is often necessary to determine how systems react to key operating conditions. Reference the *Functional Testing Checklist Tool & Test Directory* website (<http://www.ftguide.org/ftct/index.htm>) for a list of common field tests or write your own with the criteria given in Section 5.4.5. Whether in-house or contractor-led, seek O&M approval first and know why you are doing the test, how to do it, what is needed, who to include, and when to abort. Often temporary overrides or manipulation of BAS sequences is needed to support testing.

Figure 30. Typical RCx functional test tools.



Figure 31. Pre-approve, follow, and fully document procedures with a pump test form.

Requirement	Data	Initials
<p><b>Pump Test Form</b>                      Building: Central plant                      System: Hot water system                      Component or Function to be tested: HWP-X  <b>Purpose: Briefly describe the purpose of the test to be performed.</b></p>		
<p>RX team suspects secondary hot water pumps for the building to be oversized due to the substantially closed position of the discharge triple duty valve (TDV), the purpose of this test is to validate impeller size, measure current and full-open pump flows (in GPM), and determine impeller trim size.</p>		
<p><b>Instructions: Provide instructions regarding how the test results should be documented and what (if any) follow up actions are necessary.</b></p>		
<p>Record test measurements and impeller trim conditions in this form and on the pump curve. Follow up with energy savings associated with impeller trim, cost estimate, and ROI information.</p>		
<p><b>Equipment Required: Note any special test equipment requirements.</b></p>		
<p>Charged, calibrated hydromanometer (with B&amp;G fittings), crescent wrench, and 6 foot ladder to reach TDV stem</p>		
<p><b>Acceptance Criteria: Document the acceptance criteria that will indicate that the test was passed.</b></p>		
<p>Test complete when the test procedure information has been gathered, system has been returned to normal, and an impeller trim opportunity has been successfully plotted on the pump curve.</p>		
<p><b>Precautions: Document any precautions that need to be taken before, during, or subsequent to the test.</b></p>		
<p>Hot water supply temperature setpoint of 180F can cause burns as it leaks out of TDV ports, reduce hydronic temperatures for test duration. Do not force hydromanometer probes into TDV ports for risk of damaging test port seals. Do not deadhead for more than 5 minutes. Practice ladder safety. If any unexpected conditions arise during test (major leaks, pump malfunction, controls issues, etc), abort test and notify POCs.</p>		
<p><b>References: List references like technical papers, CTPL library tests and other information that might be useful as supporting information for the test team.</b></p>		
<p>Bring printouts of TDV and pump performance curves: (list model information); reference affinity laws</p>		
<p><b>Roles and Responsibilities: List the required participants, and their roles and responsibilities.</b></p>		
<ol style="list-style-type: none"> <li>RX lead: performs test</li> <li>RX test support: documents measurements and aides in test completion</li> <li>HVAC programmer: reduces (or advises on) setpoint reduction and temporary overrides</li> <li>HVAC technician: on-call to support any test problems or repair needed</li> <li>O&amp;M Chief/Foreman: awareness and prior approval of test date</li> </ol>		
<p><b>Prerequisites: List any prerequisites that must be in place</b></p>		
<ol style="list-style-type: none"> <li>Hydronic temperature must be &lt; 150F</li> <li>Two-way zone valves must be mostly open so that average valve position &gt; 85%</li> <li>Above roles &amp; responsibilities must be in place</li> <li>Equipment and references must be available</li> <li>At least one hour must be available to perform/re-perform this test</li> </ol>		
<p><b>Preparation: List steps necessary to prepare for the test.</b></p>		
<ol style="list-style-type: none"> <li>Setup hydromanometer with correct fittings and hose valves closed</li> <li>Connect the positive hydromanometer probe to the upstream TDV port</li> <li>Turn the hydromanometer on and selector switch to BYPASS</li> <li>Point the negative hydromanometer probe towards a floor drain or bucket and open both hose valves</li> <li>Bleed lines until smooth stream is present, then close both hose valves</li> <li>Connect the negative probe to the downstream TDV port</li> <li>Turn the hydromanometer on and selector switch to MEASURE</li> </ol>		
<p><b>Procedure: List actual steps in the procedure here.</b></p>		
<ol style="list-style-type: none"> <li>Note current TDV position BC</li> <li>Note current TDV hydromanometer differential pressure 80 % open BC</li> <li>Is the differential pressure above TDV manufacturer read minimum? 4.5 ft head yes/No BC</li> <li>Deadhead pump by adjusting TDV stem to 0% open 0% open BC</li> <li>Note deadhead hydromanometer differential pressure ____ft-head BC</li> <li>Adjust TDV stem to 100% open 100% open BC</li> <li>Note full open hydromanometer differential pressure 3.5 ft head BC</li> <li>Is the differential pressure above TDV manufacturer read minimum? yes/No BC</li> </ol>		
<p><b>Follow up and Return to Normal: List follow up steps here.</b></p>		
<ol style="list-style-type: none"> <li>Return the TDV stem to original position 80% open yes/No</li> <li>Remove any hot water system overrides yes/No</li> <li>Verify system returns to normal operation (boiler on, setpoint met) yes/No</li> <li>Plot flow conditions on TDV performance curve yes/No</li> <li>Plot flow conditions on pump performance curve yes/No</li> <li>Note current impeller size 9.25" diam</li> <li>Note current flow condition 440 gpm</li> <li>Note full open flow condition 550 gpm</li> <li>Plot full open system curve using affinity laws yes/No</li> <li>Note impeller trim size 7.375" diam</li> <li>Note current BHP 9.5 BHP</li> <li>Note impeller trim BHP 5.5 BHP</li> </ol>		

## 6.4 Data analysis

The off-site portion of the Investigation phases involves evaluating the data collected during on-site trending and functional testing to draw meaningful conclusions about existing or potential system performance. Rules of thumb or rough order values for possible utility savings for ECMs are acceptable to justify the Investigation phase, but at this point we should have sufficiently queried the building to validate feasibility of ECMs and be working on quantifying the associated savings.

Much of data analysis involves looking at performance trends and responses to identify patterns and relationships between different sets of data (e.g., see Figure 32). There are different tools to create trends and related analysis modules, but in general a valuable trend graph has the following features:

- Discernable time interval (x-axis) and labeled trend units (y-axes)
- One or more data series relevant to an ECM or issue investigated, in common trend intervals, and linked to primary or secondary y-axis
- Annotations for important events or conclusions about the data.

Figure 32. Example RCx trend graph (1-week economizer performance).

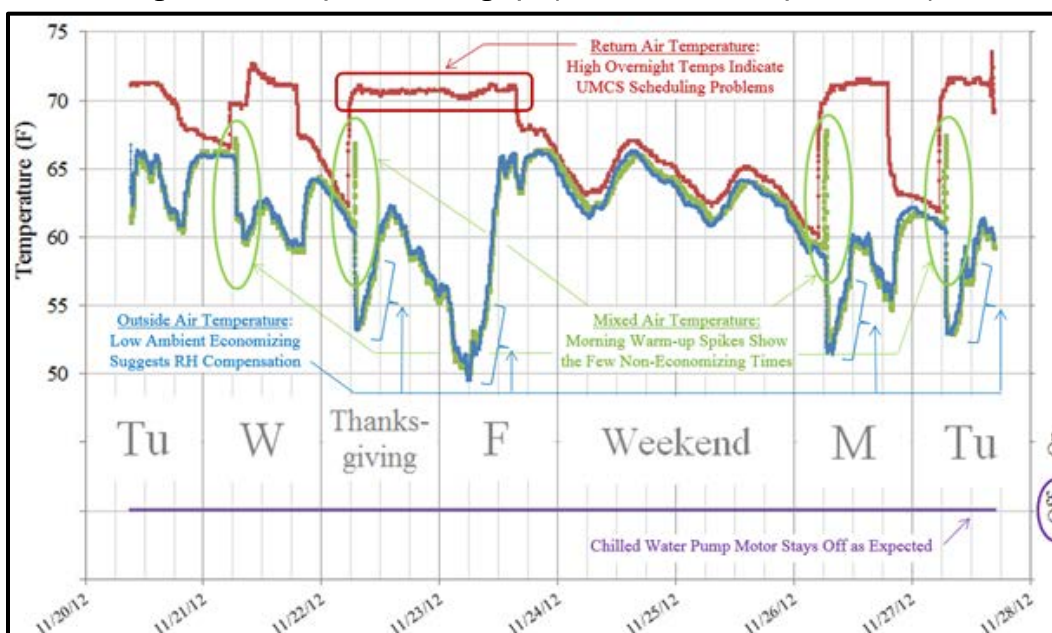

More than likely system data from BAS trends or data loggers will be exported as downloadable \*.csv or \*.txt files from logger programs such as HOBOWare or BAS front-end interfaces. This format makes Microsoft Excel® an ideal option for performing initial data analysis. As a preeminent

spreadsheet program, Excel® has a suite of chart, arithmetic, lookup, summary, and other canned functionality that is well-supported online. To perform RCx analysis, users must have a working knowledge of basic Excel® formulas, moving and looking up data, setting up and formatting charts, and associated shortcuts. Table 10 lists common Excel® shortcuts. (A full list for Personal Computer [PC] and Mac users is available as part of Chapter 10, “Resources List.”)

**Table 10. Typical Excel® commands/functions and shortcuts/formulas for RCx data analysis.**

Excel® Command or Function	Shortcut Keys or Formula
Move to the edge of a block of data	Ctrl + Arrow Key
Expand selection in direction of arrow key	Shift + Arrow Key
Expand selection to continuous data in arrow direction	Ctrl + Shift + Arrow Key
Select all continuous data	Ctrl + A
Save file	Ctrl + S
Print menu	Ctrl + P
Find (search)	Ctrl + F
Copy selection	Ctrl + C
Paste (starting at current cell)	Ctrl + V
Undo last action	Ctrl + Z
Apply filter to the top row of a table of data	Ctrl + Shift + L
Insert chart using selection data	Alt + F1
Format selection	Ctrl + 1
Apply format again (for selection cells)	F4
Locks/unlocks relative cell references in equations (\$)	F4 (on selected cell references)
Autofill using cell handle (bottom-right corner cell icon)	Drag or double-click cell handle
Add (numbers and/or references)	=SUM(1, 2, ...)
Average (numbers and/or references)	=AVERAGE(1, 2, ...)
Count (number of cells selected)	=COUNT(1, 2, ...)
Conditional statements (if, then, else)	=IF(math/logic, true value, false value)
Conditional adding option (add values meeting criteria)	=SUMIF(range, criteria, sum range)
Conditional counting option (count cells not blank)	=COUNTA(1, 2, ...)
Vertical lookup (give table value offset from reference)	=VLOOKUP(reference, table, column)
Break up a single date into its time components: year, month, day of the month, day of the week, and time	=YEAR(date), =MONTH(date), =DAY(date), =WEEKDAY(date), =TIME(date)

Excel® can be valuable for basic analysis such as correlating data series (e.g., comparison of actuator output to supply temperature), quantifying opportunities (e.g., number of hours HVAC runs with no zone motion detected), or communicating specific issues (e.g., time-series chart highlighting when setpoints or commands are deviated from). Additional analysis tools can be useful when evaluating performance data. One example is the *Universal Translator* (<http://utonline.org/cms/>), or UT3, a free software program developed by Pacific Gas and Electric’s (PG&E) designed to process and analyze interval facility data in application-specific modules (Figure 33).

Figure 33. UT3 features modules for common RCx analyses including light loads and economizer performance.

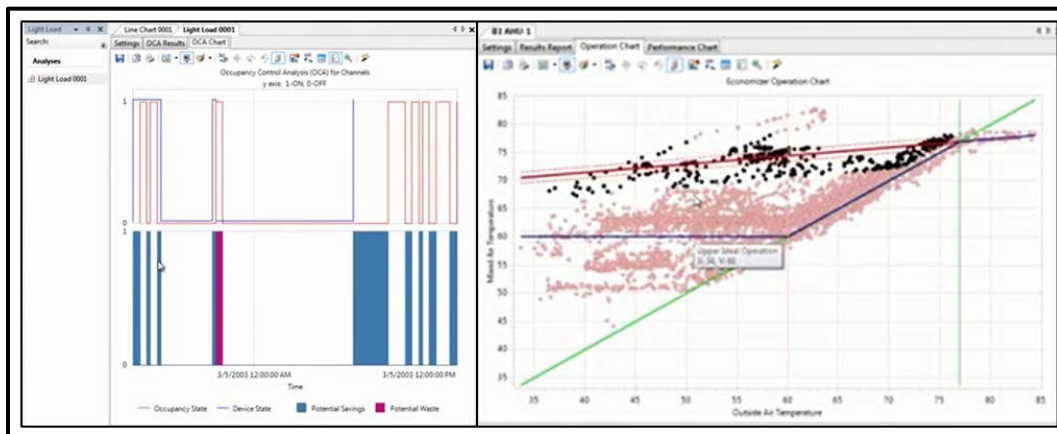

One common challenge for RCx data analysis is how to quickly combine performance data with non-synchronous time stamps. Often BAS trend data and data logger files record metrics at different or offset time intervals, can vary in start or end time, and may include change of value (COV) data at uneven collection rates. The UT3 can correct for these issues within minutes by resampling non-uniform imported data and exporting a new clean version with overlapping or specified start/stop times and common intervals for all data series (Table 11).

## 6.5 Energy calculations

Energy savings calculations should be tied to actual operations by using data collected in the Investigation phase and applied to the relevant engineering formulas (Figure 34). Where savings scenarios vary by outside air temperature, consider calculating savings by weather bin for increased accuracy.

Table 11. Raw and resampled interval data.

Raw Timestamp	Supply Temp	Valve Cmmnd	Fan Status	Resampled Timestamp	Supply Temp	Valve Cmmnd	Fan Status
7:35:00 AM	65.4	0%	1	7:35:00 AM	65.4	0%	1
7:42:13 AM	58.2	100%		7:40:00 AM	58.2	100%	0
7:49:43 AM	58.0	100%		7:45:00 AM	58.1	100%	0
7:57:13 AM	54.2	100%		7:50:00 AM	57.8	100%	0
8:04:43 AM	55.5	92%		7:55:00 AM	54.2	100%	0
8:12:13 AM	55.7	78%		8:00:00 AM	54.9	96%	0
8:17:13 AM	56.0	40%	0	8:05:00 AM	55.5	91%	0
8:19:43 AM	57.0	100%		8:10:00 AM	55.7	78%	0
8:20:00 AM	56.2	100%	1	8:15:00 AM	55.9	57%	0
8:27:13 AM	50.2	94%		8:20:00 AM	56.5	73%	1

Figure 34. Common energy calculations used during the RCx process.

**Psychrometrics:**

*Sensible loads:*  $Q = 1.08 \times CFM \times \Delta T$

*Latent loads:*  $Q = 0.68 \times CFM \times \Delta w$

*Total loads:*  $Q = 4.5 \times CFM \times \Delta h$

*Water-side loads:*  $Q = 500 \times GPM \times \Delta T$

*Economizer Outside Air Percentage:*  $\%_{OA} = \frac{T_{MA} - T_{RA}}{T_{OA} - T_{RA}} \times 100$

**Flow:**

*Air Pressure:*  $TP = SP + VP$

*Air Velocity:*  $V = 4.005 \times \sqrt{VP}$

*Air Flow:*  $Q = V \times A$

**Centrifugal Machines**

*Pump Equation:*  $P = \frac{GPM \times \Delta H}{3.956 \times \eta_p \times \eta_m \times \eta_{VFD}}$

*Fan Equation:*  $P = \frac{CFM \times \Delta p}{6.356 \times \eta_b \times \eta_m \times \eta_{VFD}}$

*Affinity Laws:*  $Q_2 = Q_1 \times \frac{N_2}{N_1} = Q_1 \times \frac{D_2}{D_1}$

$H_2 = H_1 \times \left(\frac{Q_2}{Q_1}\right)^2 = H_1 \times \left(\frac{N_2}{N_1}\right)^2 = H_1 \times \left(\frac{D_2}{D_1}\right)^2$

$BHP_2 = BHP_1 \times \left(\frac{Q_2}{Q_1}\right)^3 = BHP_1 \times \left(\frac{N_2}{N_1}\right)^3 = BHP_1 \times \left(\frac{D_2}{D_1}\right)^3$

*Motors:*  $LF = \frac{RPM_{sync} - RPM_{meas}}{RPM_{sync} - RPM_{rated}}$

**Electrical:**

*DC Load:*  $P_{DC} = \frac{I \times V}{1,000}$

*AC:*  $P_{1\phi} = \frac{I \times V \times PF}{1,000}$

$P_{3\phi} = \frac{I \times V \times PF \times \sqrt{3}}{1,000}$

**where:**  $Q =$  heat load (Btu/hr)  
 $CFM =$  cubic feet minute airflow  
 $GPM =$  gallons per minute water flow  
 $\Delta T =$  change in air or water temp ( $^{\circ}F$ )  
 $\Delta w =$  change in humidity ratio (gr/lb<sub>a</sub>)  
 $\Delta h =$  change in specific enthalpy (Btu/lb<sub>a</sub>)  
 $\%_{OA} =$  outside air fraction  
 $T_{MA} =$  mixed air temp ( $^{\circ}F$ )  
 $T_{RA} =$  return air temp ( $^{\circ}F$ )  
 $T_{OA} =$  outside air temp ( $^{\circ}F$ )

**where:**  $TP =$  total air pressure (in w.c.)  
 $SP =$  static air pressure (in w.c.)  
 $VP =$  velocity pressure (in w.c.)  
 $V =$  velocity (feet per min)  
 $Q =$  airflow (cubic feet per minute)  
 $A =$  flow area (square feet)

**where:**  $P =$  pump or fan power (kW)  
 $CFM =$  airflow (cubic feet per minute)  
 $\eta_p =$  pump efficiency (40%-80%)  
 $\eta_m =$  motor efficiency (75%-95%)  
 $\eta_{VFD} =$  variable frequency drive efficiency (95-99%)  
 $GPM =$  water flow (gallons per minute)  
 $\eta_b =$  drive belt efficiency (90-99%)  
 $Q =$  flow (cubic feet per minute or gallons per minute)  
 $N =$  speed (rpm)  
 $D =$  diameter (in)  
 $H =$  pressure (inches of water column or feet of head)  
 $BHP =$  brake horsepower  
 $LF =$  induction motor load factor  
 $RPM =$  synchronous, measured, or rated speed (rev per min)

**where:**  $P =$  electrical power (kW)  
 $I =$  current (amps)  
 $V =$  voltage (volts)  
 $PF =$  power factor

## 6.6 Final ECM list

Following data analysis and energy calculations, organize final ECM selections by viability and either utility savings or costs. Discuss ECMs with O&M, BAS, and related stakeholder staff to determine the execution method that may be most appropriate for each ECM and, if possible, separate ECMs by their expected implementation route. See the following section for more information on implementing RCx ECMs.

## 6.7 Issues and Resolutions Log

As was done during the RCx Assessment period, continue to update the Issues & Resolution Log with additional problems discovered and any action required or taken to resolve them. With buildings in operation, system components may fail, be replaced, or require follow-up in parallel to RCx efforts. Make sure these events are documented in the Issues and Resolutions Log along with any general or ECM-specific impacts to facility performance.

## 6.8 Investigation phase report

Where contracted or otherwise required, organize the results of the Investigation phase into a final report. Report contents may be user-defined or project-specific; however recommended sections include:

- Executive Summary (brief narrative on project-specific RCx work performed and final ECM table generated)
- Utilities Summary (rates used, usage charts, eligible rebates, etc.)
- Site Activities Summary (description of tasks performed on-site, coordination performed, and Issues & Resolutions Log items)
- ECM Descriptions (separate breakdowns on each ECM including discovery, trend, testing, calculations, and assumption processes)
- M&V Recommendations (overview of M&V strategies that can be integrated into an updated Monitoring Plan where ECM validation is required)
- Systems Manual Information (list of documentation missing or outdated that should be included as digital or hard copy for O&M staff such as as-builts, control drawings, points schedule, TAB reports, equipment manuals, warranty procedures, performance curves, or laminated system diagram sheets for mechanical rooms, etc.)
- Appendix Documents (include any referenced or updated documents including Monitoring Plan, Functional Test sheets, Issues & Resolutions Log, Trend Logs, meeting minutes, etc.).

## 6.9 Design or construction improvements

Whether or not specific ECMs were determined to be cost-effective to implement, ECMs representing an issue with how relatively newer Army projects were designed, built, or commissioned should be highlighted. If certain design methodologies implemented from Army specifications or criteria had negative system performance consequences, consider submitting a Criteria Change Request (CCR) through the WBDG website (<http://www.wbdg.org/>). Regardless, discuss these findings with local engineering, project management, and design staff to develop the requisite awareness for catching related problems as far upstream as possible (Figure 35). At the present moment, the RCx process is the best opportunity available for assimilating best practices on the operations side into the world of Army design and construction.

Figure 35. Issues like unnecessary discharge plenum and poor discharge fitting should be recorded as design and construction lessons learned.

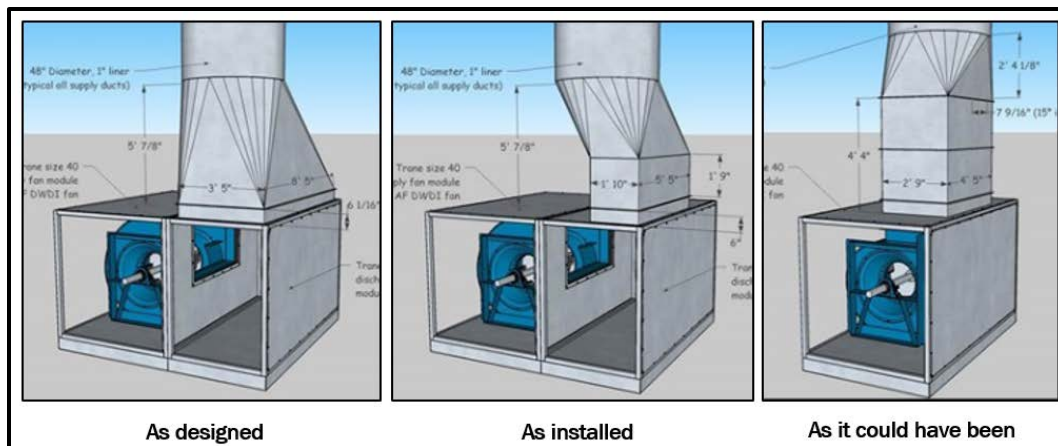

## 7 Implementation/Hand-Off

In this phased approach to RCx (Figure 36), one may wonder when exactly things are fixed or improved. In short, an ECM may be implemented immediately, iteratively, or on an as-fails basis.

Immediate implementation would occur when an easy fix is apparent at any point in the RCx process. An example would be when a hardware or software override is discovered by RCx team members and returned to automated control. This override may have happened while troubleshooting a comfort complaint; during routine maintenance; or while performing spot testing/repair work, when the system was inadvertently left in the manual (24/7) mode. As long as the override is not masking a more systemic problem, returning the system to automated control would return the equipment to the programmed schedules and sequences for immediate savings. This no-cost implementation does not require additional purchasing or contracting to complete.

Iterative implementation might occur when a particular repair needs to occur before the rest of the system can be fully investigated or when changes made need to be checked and tweaked repeatedly before targeted results are achieved. For example a BAS network, communication, or access issue may need to be repaired before adequate investigation of equipment can occur. Or perhaps a new controls sequence such as DSP setpoint reset is recommended, but seen to be underperforming and in need of programming alteration. Often times, RCx will follow this iterative approach with cascading discoveries and an evolution in understanding system operations.

Figure 36. Steps and documentation for implementation.

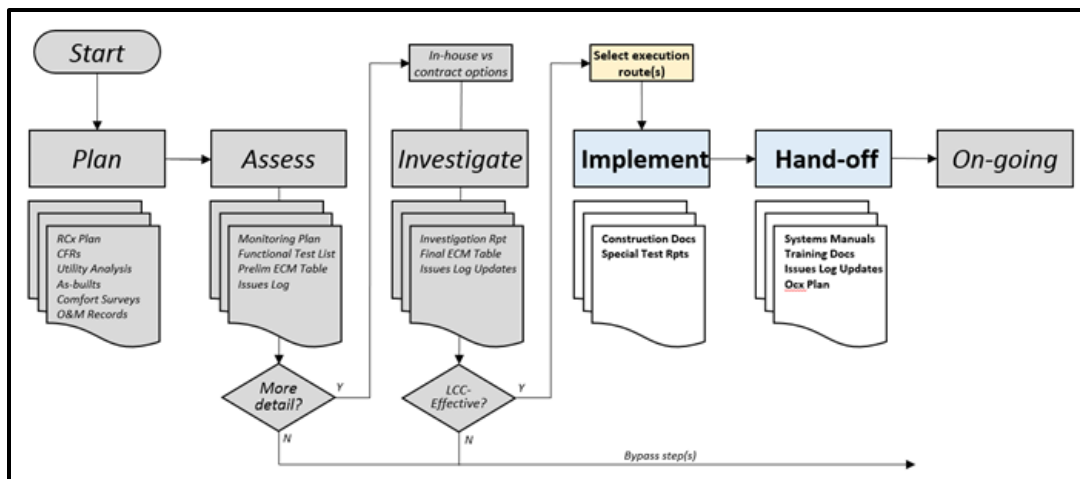

As-fails implementation puts off repairs or changes until some future date. As-fails implementation is a common approach to systems that have readily available spare parts, are scheduled for impending O&M replacement, or could benefit from resizing or new features when failure occurs. As-fails implementation can also be used if new or expensive, albeit suboptimal, equipment has recently been installed in an effort to glean some value from the recent or high-dollar purchase. It may even be standard operating procedure for facilities with limited O&M funding or staffing. Fortunately, RCx often identifies and prioritizes both efficiency improvement opportunities and backlogged maintenance issues and provides justification for their being addressed.

Although implementation may follow one of the above mentioned paths, typically, ECMs can be grouped into Implementation phase packages that are completed after the Investigation phase through a number of different execution routes. While many phases of RCx may be independently performed or contracted, the Implementation and Hand-off of any individual ECM is necessarily conducted by the same project delivery team whether it is an in-house or contracted group. The Implementation phase will be a set of tasks that is familiar to most facilities management staff that oversee construction or service contract work in their buildings. The goals of the Implementation Phase are to select the ECMs, select the execution route(s), implement the selected measures, and verify or performance test that these measures achieve the expected benefits. The Hand-Off Phase should be similarly recognizable. Its goals are to provide the O&M team at the facility with the information, training, and procedures to ensure persistence of benefits. This phase will be shaped by earlier RCx phases that may reveal specific testing, training, and documentation needs for resilient O&M once Implementation is complete.

## 7.1 Implementation execution routes

ECMs may be implemented through in-house means, existing contracts, or new acquisition processes. Regardless, use the results of the Assessment or Investigation phase to set the required tasks during Implementation. In order of simplicity, typical execution routes for Army RCx Implementation ECMs include:

- **O&M work order:** Using existing O&M service request mechanisms, work with local O&M staff for small low/no-cost changes to the facility. Examples of this kind of ECM Implementation include economizer

- damper repairs, valve replacements, or lighting system time clock installation.
- **BAS programmer:** Where changes are required to existing automation system sequences or setpoints, coordinate with the in-house or contracted BAS programmer to backup files, make edits, test changes, and backup again. Where no pre-existing means for making BAS changes exists, consider a credit card request to acquire BAS site support from a qualified entity and note the missing role of a BAS programmer to facilities management staff.
  - **Locally-funded project:** Certain RCx implementation efforts may be appropriate as Sustainment, Restoration, and Modernization (SRM)-funded work off the installation's annual budget and executed through a local O&M shop or base operations contract, job order contract, or the local contracting command. This type of implementation could include various equipment repair, replacement, or retrofit projects to be budgeted in the current fiscal year.
  - **Centrally-funded project:** Where additional funds or end-of-year unobligated money is available through central command organization, be prepared with an implementation package that includes scope of work, government estimate, work request number, and life cycle cost estimate information to justify the RCx implementation requested.
  - **Externally-funded project:** Some RCx implementation may qualify for funding through externally-funded sources due to their utility-savings, innovative, or resiliency-promoting nature. Energy Efficiency and Utilities Modernization (QUTM), Energy Resilience & Conservation Investment Program (ERCIP), other Military Construction (MILCON) funding may be appropriate for large capital improvements recommended through the RCx progress or improved design methodologies that could be integrated into a larger renovation or deep energy retrofit effort.
  - **Third-party financing:** The Federal Energy Management Program (FEMP) provides federal agencies with assistance, resources, and training to use Utility Energy Services Contracts (UESCs) or Energy Savings Performance Contracts (ESPCs) to implement projects. UESCs are contracts with utility companies. ESPCs are contracts with ESCOs. These contract mechanisms are innovative arrangements for designing, installing, and financing energy improvement projects where the savings achieved by the project are guaranteed to amortize the cost of the project over the term of the agreement. UESCs and ESPCs are typically long-term agreements (10+ years) and are adaptable to site specific

needs. For more information and support services for these contracting mechanisms, contact your local contracting office or visit FEMP's project financing webpage (<https://energy.gov/eere/femp/federal-energy-and-water-efficiency-project-financing>).

- **Utility Rebate:** There are numerous utility and state sponsored programs that offer technical assistance, efficiency equipment and/or financial rebates for energy efficiency projects. Additionally there are sometimes state and federal grants, tax deductions, and tax credits available for select efficiency projects. Funding and program requirements vary widely, but in some instances, funding has provided up to the total cost of efficiency projects. For information on these programs by state see the Database of State Incentives for Renewables and Efficiency (DSIRE) (<http://www.dsireusa.org/>).

## 7.2 Implementation activities

### 7.2.1 Selection of measures

The selection of which particular measures to implement and their prioritization and scheduling will be site specific and may depend on pressing operational needs, availability of funding or other resources, ease of execution path, expected energy or cost impact, or ability to further sustainability goals.

Often all low and no-cost RCx measures will be selected for short term implementation due to their low cost, quick return, and immediate impact. However, if capital intensive projects are identified and desired, bundling of projects is common to combine quick return projects with longer return efforts to achieve attractive economics with larger impact and to qualify for utility incentives.

If all projects are not selected for implementation, the favorable ordering of projects to maximize benefits and minimize costs should be considered. Typically it is most cost effective to stage project implementation from energy end use first, and then to proceed through the system, through distribution, and last to energy production. For example, if changes are made to the rooms where people live and work (such as replacing a room thermostat or repairing a window), before replacing generation equipment (such as a boiler), the size (and cost) of the boiler could potentially be reduced due to reduced load from earlier projects.

If capital projects are included as part of the RCx process, it may be appropriate to execute them first (with anticipated downsizing) and finish with fine tuning of operations and control after installation.

### 7.2.2 Implementation coordination

Installation of measures should follow best practices and meet the specifications detailed in the measure descriptions. Involving local O&M staff to some degree in the installation, at least with discussions and some show-and-tell will provide informal training and help create a culture of efficiency (Figure 37).

Figure 37. Stakeholder coordination can be critical, such as this example where middle of the night scheduling off of certain exterior lights required approval from the installation Safety Manager and Security Officer.

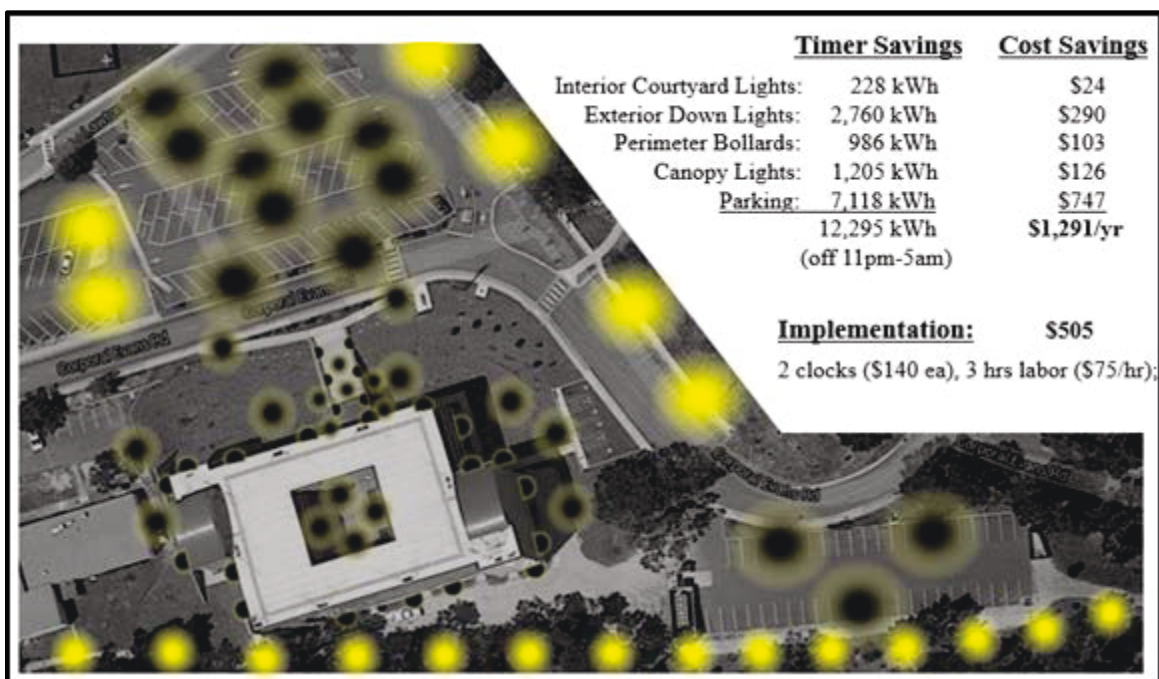

### 7.2.3 Verification of measures

Capital improvement projects should be implemented and tested according to Army specifications. Specifically, Unified Facility Guide Specs (UFGS) 01 91 00.15 for Total Building Commissioning and the Division 23 and 25-series of specifications for HVAC controls and UMCS are important resources for typical RCx implementation and the performance verification testing that should follow.

For the measures involving existing systems and assemblies, some of the same functional performance testing and/or data trending that occurred

during the Investigation phase will often have to be repeated to ensure that you get what you paid for and get what you need. These tasks will follow the M&V plan. The resulting equipment and facility operations after implementation should be evaluated against CFR to understand if corrections and improvements were successfully implemented, and desired outcomes are attained. If the provisions of the CFR are not met, then operational parameters should be adjusted until they are attained, or a plan to attain the CFR in the future should be developed (if discoveries during implementation are significantly more complex than what was anticipated or budgeted for), or the CFR should be changed to reflect attainable operations. The CFR is a living document that reflects the operations that the stakeholders are willing to support both financially and operationally. Deeper understanding gained during implementation may change the mind of stakeholders regarding required outcomes.

Verified changes should be documented with after-installation inspection and test reports, updated issues and resolution log, operational setpoints and data trends, photos, and UMCS screenshots as appropriate. If system components have changed, construction documents, specification sheets, and operating procedures should be added to the systems manual.

### 7.3 Hand-off criteria

As with any facilities management implementation work, there is an appropriate way to hand-off system operations to O&M staff. The objective of a hand-off is to fully equip the facility staff with the information, insights, and procedures needed to successfully operate the modified facility.

Develop hand-off criteria as a basis for adequate transitioning of operational authority of the modified facility. Some tasks for that transition will include:

- **Review of special performance testing:** Verify that post-installation performance testing demonstrates desired outcomes and that any impacts to the CFR are understood and agreed upon.
- **System Manuals:** Update and augment systems documentation with an Implementation and Verification Report that explains the changes made and the methods followed, and includes inspection and test reports, construction documents, updated Issues and Resolutions Log, operational setpoints, schedules and control sequences, ongoing maintenance requirements, calibration procedures, lessons learned etc.

- Provide pertinent information to support maintenance activities. This may include contact information for vendors or potential mechanical servicing, equipment vendor hot lines for operational support, zone maps, troubleshooting guidelines, etc. Establish that necessary documentation is complete and gathered and deposited in an appropriate location that is accessible to the needed users.
- **Operator Training:** Provide a formal training workshop for building O&M staff that reviews changes made, expected benefits, and lesson learned from the RCx effort as well as recommendations for ongoing operational indicators, troubleshooting guidance, and periodic functional testing procedures. Be sure to include a field-based show-and-tell and ample time for questions and answers. Provide training documentation for future reference.
  - **Ongoing Commissioning (OCx) Plan:** In collaboration with the operational staff, develop an OCx Plan that seeks to reduce barriers to sustained idealized operations. Some common barriers include: missing documentation, incorrect documentation, lack of contacts for assistance, lack of adequate training, lack of familiarity with equipment or insufficient comfort level with new control schemes, lack of sufficiently distilled operator instructions (cheat sheets) to perform complex procedures, either insufficient or too much UMCS alarming, lack of timely feedback on operational changes, insufficient time or funds to address operations, and lack of institutional policies to govern operations. The OCx Plan will include some identification of performance indicators for ongoing monitoring, tracking, and reporting of measure persistence.
  - **Acceptance:** Final acceptance and beneficial use of RCx Implementation and Hand-Off efforts when the above criteria and other project specifics have been met will trigger any warranty start periods and the beginning of the OCx Phase. If project scope calls for post-project return testing, balancing, or verification, ensure that contractors and contract officer staff are aware of how future scheduling, invoicing, and reporting should be structured.

## 8 Ongoing Cx

While the OCx phase (Figure 38) is not strictly necessary to achieve a successful RCx *event*, the success of the overall RCx *process* depends on ensuring that facility systems are being watched for slips in performance. Studies show that over time, savings from RCx can degrade\* and the RCx has begun to focus on technical solutions for energy savings retention planning (Figure 39).

Building performance, however relies on more than just our HVAC or lighting systems. Recognizing that people are part of the energy systems of a facility and incorporating occupants in RCx solutions is a key to ongoing success. The ultimate goal of persistence planning is an organizational cultural shift to support improved and sustained facility performance.

Ongoing Commissioning is thus a mix of technology and culture change intended to improve building energy consumption and continuously optimize building performance during its entire lifecycle. OCx is the process of regularly ensuring that building operations continue to stay optimized beyond RCx Implementation and Hand-Off Phases. Specific industry applications of OCx include Continuous Commissioning® (CC®), Monitoring-Based Commissioning (MBCx), and a number of customized data analytics, fault-detection software, and persistence savings SOPs.

Figure 38. Steps of ongoing Cx.

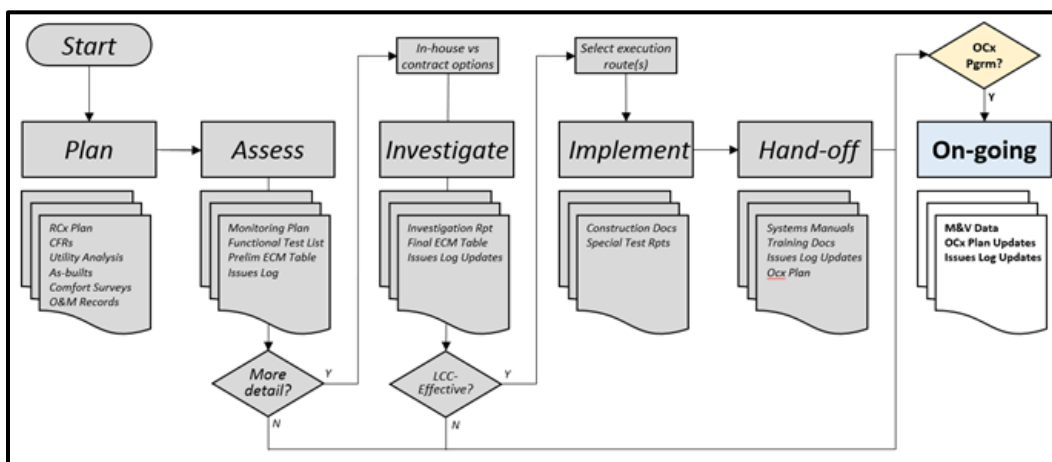

\* IEA Annex 47 Subtask C Final Report, 2009, SBW Final Report 2006-8 CA RCx Impact Evaluation, 2010.

Figure 39. LBNL's 2009 study highlights the need for sustaining or improving RCx savings.

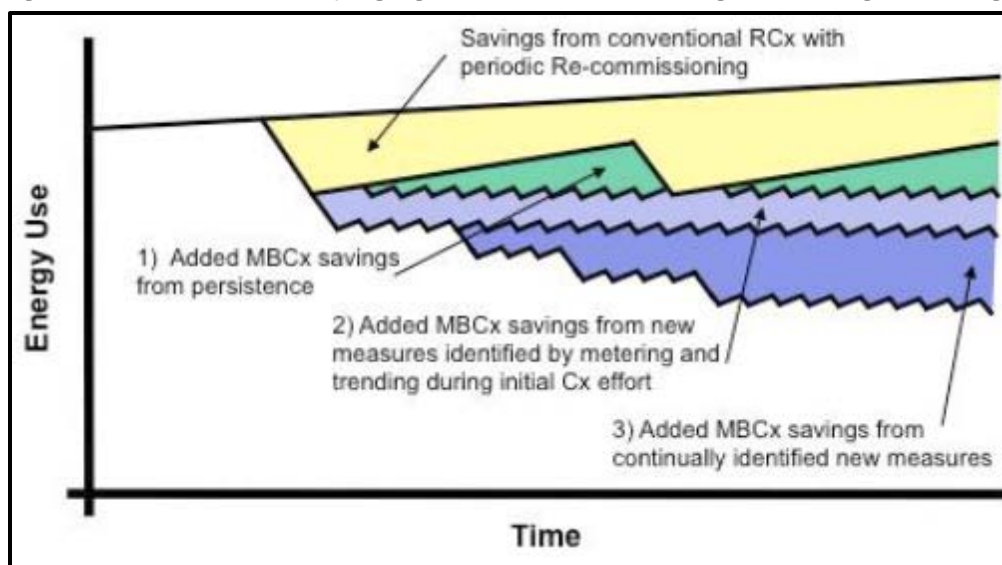

## 8.1 Ongoing commissioning (OCx) process

Assemble a broad spectrum OCx team and review the OCx Plan. Discuss objectives, roles/responsibilities, and determine frequency of activities. Review the building systems, modifications made, and ongoing maintenance or training requirements. Identify key performance indicators for ongoing tracking. Update the OCx Plan begun in the Hand-Off Phase. Include a Measurement and Verification Plan, a controls calibration plan, an Issues Log Update, and a schedule for periodic OCx Plan update.

Discuss Barriers and Responses. Persistence planning should include the OCx team brainstorming on potential barriers to persistent savings, then proceed to developing a means for removing or mitigating those barriers.

Common barriers are ease of access to correct and pertinent information, limited funding and staffing, insufficient training, insufficient comfort with new control schemes, and insufficient buy-in to the changes. Additionally, staff turnover, evolving technologies, and competing or shifting priorities of facility stakeholders make for a full array of challenges.

Implement the OCx Plan with an expectation of a continuous improvement process. There will be a need to “plan-do-check-adjust” efforts in a repeating cycle over the life of the facility.

## 8.2 OCx Plan outline

An OCx Plan should be developed to identify the “who, what, where, when and how” of facilities operations, and the performance metrics that are to be tracked. This plan can be developed at any time, but is particularly valuable following the RCx Implementation Phase. The plan should include the following:

- Introduction: discussion of building systems
- Understanding the RCx implemented measures
- Performing O&M persistence activities
- Tracking Building energy performed over time (benchmarking, energy use analysis, and functional testing)
- Review training needs
- Appendices (RCx Reports, CFR, sequence of operations, Sensor Recalibration Plan, Issues & Resolutions List, etc.).

## 8.3 Common OCx activities

The following possible OCx tasks may be performed in-house or contracted on a service or Indefinite Delivery Indefinite Quantity (IDIQ) basis.

### 8.3.1 Information access

Some best practices for addressing information access issues include centralizing documentation and providing ready access to information.

**Central Files:** In addition to a hard copy binder of the Systems Manual in the O&M shop, a common computer server with electronic files of the Systems Manual can provide an accessible repository of information that can weather changes in staff who may not pass on all the files on their PC before they leave employment.

**Posted Information Sheets:** Additionally, posting laminated sheets of HVAC zone layouts, system diagrams, equipment control sequences, and operator instructions (cheat sheets) near associated equipment can provide service workers with the information they need. Posting instructions for occupant use of thermostats, lighting switches, or occupancy sensors may also be appropriate.

**Internal Connections and Remote access to UMCS:** Consider establishing UMCS connections for key employees and contractors. These

could include internal connections (on-base but away for the UMCS front end) and remote access (for off-base connections). This would require working with local IT personnel to review the network layout, the risk management framework (RMF), and appropriate means of connection. Guidance from the Unified Facilities Criteria (UFC) 4-010-06, Cybersecurity of Facility-Related Control Systems, should be incorporated. Use of a Virtual Personal Network (VPN) encrypted connection is a secure hole through a network's firewall and may be adequate protection for remote access. Requirements for users having Common Access Cards (CACs) (which requires regular security training) are appropriate. Depending on the system layout, a remote desktop connection may allow desired access. Options for screen sharing from the UMCS should also be reviewed. One solution could be a tight virtual network connection (VNC).

These options for access to the UMCS can greatly facilitate system monitoring and troubleshooting and reduce travel requirements and costs by allowing building operators and their assistants to access and discuss facility operations and potentially quickly resolve issues without scheduling an on-site meeting.

**UMCS graphics upgrades:** Intuitive graphical interfaces in the UMCS can go a long way toward giving key players the needed information to diagnose and resolve equipment operational issues. Suggestions on interface upgrades and corrections should be collected on an ongoing basis and incorporated where possible. Some UMCS systems provide links to system manual material, ongoing data trends, and equipment schedules for ready access to useful information.

### **8.3.2 Targeted data analysis for new control schemes**

It is understandable that building operators may not be comfortable with new control schemes in their facilities. Concerns should be discussed, and addressed with data collection if appropriate. For example, building operators at a facility that have historically run all HVAC equipment 24/7 could be concerned that new occupancy based schedules or optimal start routines may not achieve comfort conditions in the space before occupancy. These concerns would be heightened during extreme weather conditions. In this case, it is advisable to monitor room temperature recovery times in typical and extreme conditions to establish confidence and buy-in for the operators. This extra step will help retain energy savings.

### **8.3.3 Periodic or continuous benchmarking**

Select facility operational metrics that are meaningful to facility stakeholders and that represent achievement of desired operations. Some potential metrics could include: EUI, Energy Star Score, energy costs, maintenance costs, number of comfort complaints, or air CO<sub>2</sub> levels.

Measure or calculate metrics periodically to identify changes in performance over time. Compare periodic metrics with established baseline levels for the facility or with other similar facilities by using the CBECS, Energy Star Portfolio Manager, or the Army's Meter Data Management System (MDMS). The data comparison is used to find variances from normal operations that may indicate a need for attention.

### **8.3.4 Benchmarking Army buildings using MDMS**

The Army has worked in the past several years to install advanced meters for central access to building-level data energy data. Meter data is managed in a standard format accessed through the MDMS (see Figure 40). A pilot program to establish benchmarks was completed by PNNL based on calibrated energy modeling for five common unique Army buildings:

- Brigade Headquarters (BH) – Office, data center
- Company Operations Facility (COF) – Administrative, training
- Dining Facility (DFAC) – Cafeteria
- Tactical Equipment Maintenance Facility (TEMF) – Vehicle maintenance shop
- Unaccompanied Enlisted Personnel Housing (UEPH) – Barracks.

These benchmarks place EUI targets on live energy manager MDMS utility reports. The PNNL EUI study will extend to additional facility types in the future.

Figure 40. MDMS may help support Army installations OCx efforts.

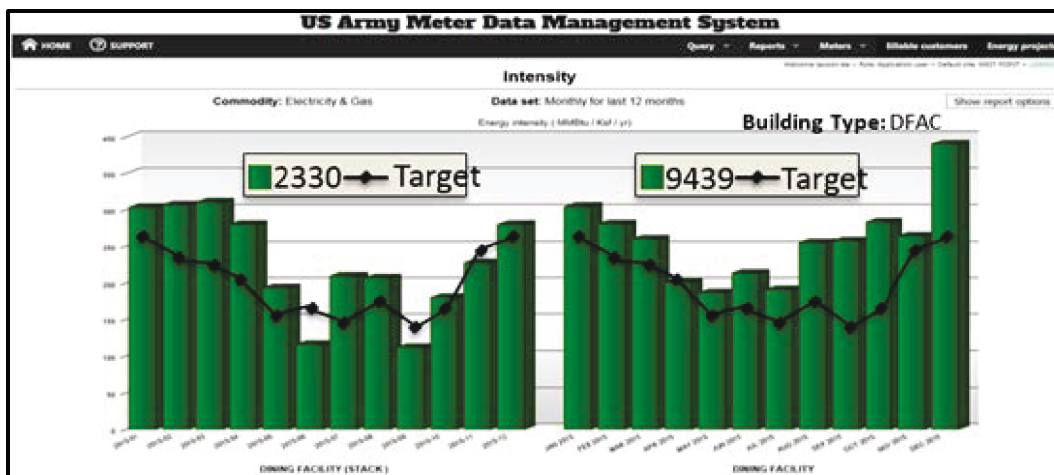

The goal is to understand consumption patterns and identify variances that trigger further investigation. For example, Figure 41a shows annual EUI (kBtu/SF) for individual COF buildings in Climate Zone 5B compared to an established Army benchmark. In Figure 41b, monthly electricity and natural gas consumption (kBtu/SF) EUI trends are shown for a single COF building compared to benchmark consumption trends developed from its previous year’s data (blue and green lines). The actual gas consumption shows as higher than usual. The OCx Plan should designate the team members who are responsible for identifying, investigating, and correcting issues limiting sustained building performance.

Figure 41. Data analysis continues into the OCx Phase with continuous or periodic reviews of performance.

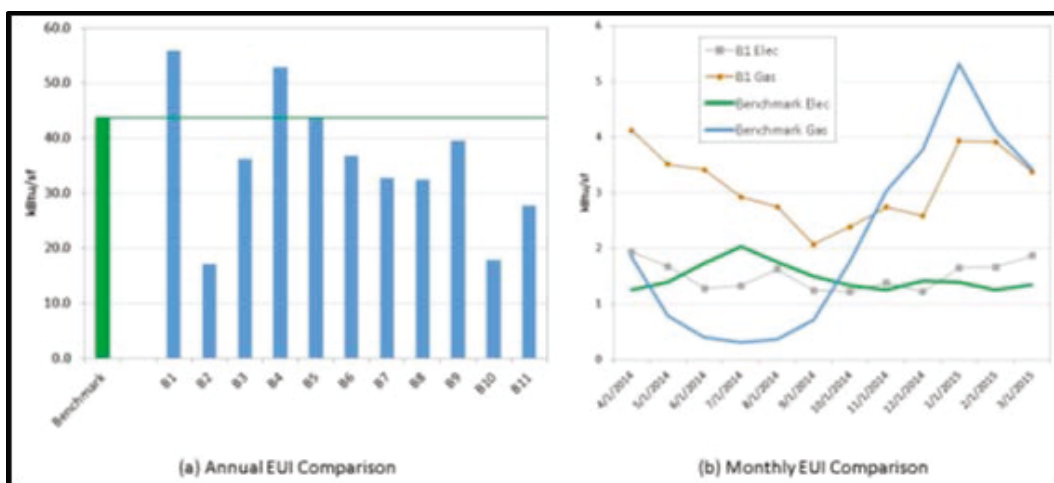

### 8.3.5 Ongoing monitoring

Tracking building performance can occur using whatever tools are available. Tools can vary from simple to complex, and can collect data from the building as a whole, or data from the equipment level (Figure 42). Simpler tools measure energy in the whole building and can be used to measure against a similar building type and size or even the previous year's data for the same building.

Army buildings larger than 29,000 sq ft were eligible for the Army's Metering Program and should have utility data available at <https://mdmsreports.army.mil/> that can support this simple benchmarking process. Many newer buildings also have interval energy data available through the BAS to support benchmarking and more complex automated fault detection and diagnostics.

Figure 42. Level of OCx monitoring varies in complexity.

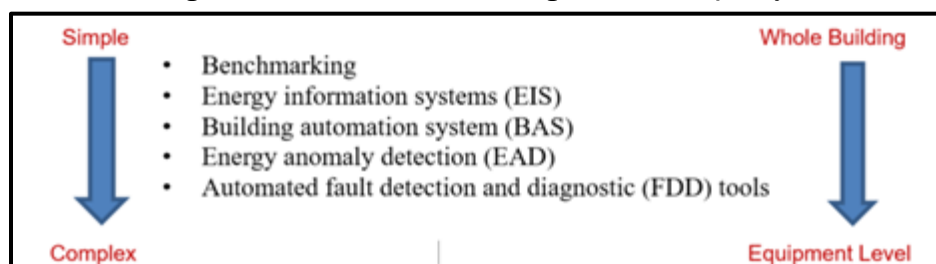

By continuously reviewing the selected data, trends will appear. Deviations from “normal” trends require investigation and action. This can identify out-of-tolerance equipment so it can be repaired or re-tuned before it wastes energy and money.

Figure 43 shows monthly natural gas use at a facility along with Heating Degree Days (an indicator of the weather). Although gas use historically tracked the weather patterns, the loss of the scheduling program (after a power outage) caused energy use to increase beyond expected weather dependent levels. Once the scheduling program was reactivated, energy use returned to expected levels.

Figure 43. Combining energy and weather datasets can offer highlight operations issues.

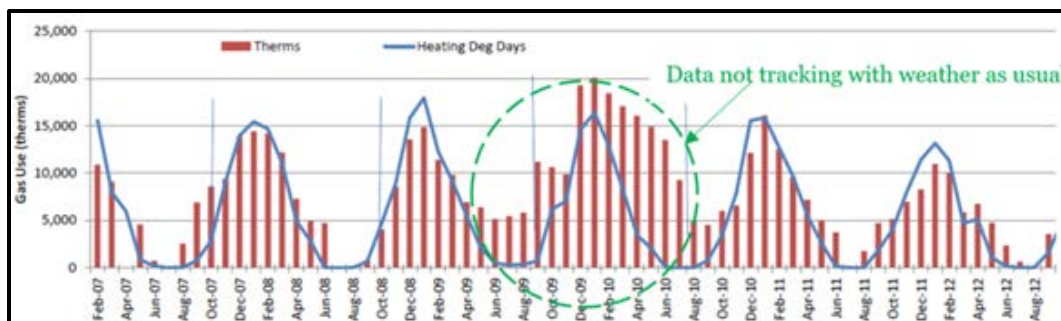

### 8.3.6 Data analysis

Periodic review of data sampling from the BAS, similar to the RCx Investigation process, can uncover building operational faults that prevent the facility from operating optimally. Checking for a temperature change across a closed coil could indicate a leaking valve. Sensors outside of expected ranges could indicate sensor failure, inappropriate sensor placement, inappropriate sensor addressing, or need for calibration. Review of air handler operations can reveal if appropriate (but not excessive) amounts of outdoor air are being brought in for economizer free cooling, if minimum ventilation rates are advantageous, and if control schemes are being followed. Discovered faults from sampled data may indicate that a more thorough combing of operations is justified.

### 8.3.7 Notification systems

HVAC system alarms and operational dashboards can provide real-time feedback on building operations to allow for rapid resolution of operational faults. There are systems that can text or email notifications to identified persons to ensure that critical building faults do not go unnoticed. Cybersecurity procedures may make the notification process challenging; however Army facilities have had success in including this feature into network accreditation packages such that configured BAS alarms are approved for external transmission to O&M staff, BAS programmers, and Energy Managers.

### 8.3.8 Automated fault detection and diagnostics

Software programs are available that can automatically perform data analysis of BAS data trends and produce reports of potential issues. These programs allow for a more thorough review of operational parameters than could be done in a non-automated fashion. If these systems are used, there should be a plan for reviewing and responding to the issues found. Newer BAS front-ends

may support a degree of automated fault-detection; otherwise, consider working with installation network staff to determine the path for installing and operating separate Fault Detection Diagnostics (FDD) software per the requirements of *UFC 4-010-06, Cybersecurity of Facility-Related Control Systems* (<https://www.wbdg.org/ffc/dod/unified-facilities-criteria-ufc/ufc-4-010-06>).

### **8.3.9 BAS activities**

Most BAS systems should be visited at least briefly on a daily basis to make sure that they or the systems they monitor and control are not malfunctioning. Primary tasks include making sure that control networks are up and communicating, sensors are within range, systems are in automated control (not in override) and that critical systems are out of high priority alarm. Sensors will need to be periodically calibrated and failed equipment will need to be replaced. Software will need to be kept up to date. Operational anomalies will need to be investigated. If there is not a dedicated controls person on site, it makes good sense to establish a routine UMCS maintenance contract. Operational questions should be logged by facility operators on a continual basis for resolution during regularly scheduled maintenance visits. If remote access to the UMCS is made available to the controls contractor, it may be appropriate to contract for some phone consultations that can quickly address system issues.

### **8.3.10 Periodic functional testing**

Schedule periodic functional testing as part of routine O&M tasks for key systems that tend to fail, such as AHU economizer functions. An easy test is to move AHU dampers through their full stroke of motion. This may uncover issues with failed or sticking dampers, loose electrical or mechanical connections, or failed actuators, etc.

### **8.3.11 Facilitated stakeholder discussions**

Since energy systems include people, there will be times when stakeholders have differing opinions regarding the best approach to facilities management. At those times, it is important to bring the people together and facilitate a conversation to listen to people's viewpoints and concerns and attempt to develop a plan jointly that meets as much of people's desires as is practicable. Often when folks are aware of the competing objectives, and the real world constraints, they will be willing to compromise for the common good.

## 9 Deliverables Summary

Table 12 lists example data of an RCx submittal register where specific deliverables are selected depending on the RCx phases and tasks desired.

Table 12. Example RCx submittal register.

Phase	Part of Bid Schedule	Submittal	Recipients	Format	Qty
Planning	X	Utilities Evaluation Report and Weather Bin Data	DPW, PM	.xlsx	1
		Occupant Thermal Comfort Survey Data	DPW, PM	.xlsx	1
	X	RCx Planning Workshop Agenda	RCx Team	.docx or .xlsx	1
		CFR Template	DPW, PM	.docx	1
	X	Completed CFR (for each building)	DPW, PM	.docx	1 ea
		RCx Team Roster	RCx Team	.xlsx or .docx	1
Assessment		RCx Plan	RCx Team	.docx	1
			DPW	8.5"x11" (color)	2
		Pre-Assessment Meeting Minutes	RCx Team	.docx or .pdf	1
	X	Equipment Inventory	DPW, PM	.xlsx	1
	X	System Diagrams (for each system)	DPW, PM	.pdf	1 ea
		Preliminary Opportunities List	RCx Team	.xlsx	1
	X	Monitoring Plan	DPW, PM	.xlsx	1
	X	Functional Test Templates (for each test)	DPW, PM	.docx or .pdf	1 ea
			RCx Team	.docx or .pdf	1
	X	Assessment Report	DPW	8.5"x11" (color)	2
		Issues & Resolution Log	RCx Team	.xlsx	1
	Investigation		Pre-Investigation Meeting Minutes	RCx Team	.docx or .pdf
X		Investigation Phase Training Agenda	RCx Team	.docx or .xlsx	1
X		Functional Test Sheets (for each test)	DPW, PM	.docx or .pdf	1 ea
X		Monitoring Plan Logger Data	DPW	CD	1
		ECM Table	RCx Team	.xlsx	1
X		Investigation Report	RCx Team	.docx or .pdf	1
			DPW	8.5"x11" (color)	2
X		M&V Monitoring Plan	DPW, PM	.xlsx	1
Implementation		Updated Issues & Resolution Log	RCx Team	.xlsx	1
		Environmental Protection Plan	DPW, PM	.docx or .pdf	1
		Safety and Accident Prevention Plan	DPW, PM	.docx or .pdf	1
		Security Training Certifications	DPW, PM	.docx or .pdf	1
		Quality Control Plan	DPW, PM	.docx or .pdf	1
		Equipment Submittals	DPW, PM	.docx or .pdf	1
		On-Site Progress Reports (for each week)	RCx Team	.docx or .pdf	1 ea
		Updated Issues & Resolution Log (as nec)	RCx Team	.xlsx	1 ea
		Equipment Start-Up Sheets (for each piece)	DPW, PM	.docx or .pdf	1 ea
	X	Preliminary TAB Report	DPW, PM	.docx or .pdf	1
			DPW, PM	.docx or .pdf	1
			DPW	8.5"x11" (color)	2
		PVT Sheets (for each system)	DPW, PM	.docx or .pdf	1 ea
		Rebate Application Copies (for each rebate)	DPW, PM	.docx or .pdf	1 ea
Hand-Off		Endurance Test Data	DPW, PM	.xlsx	1
		FG Sheets (for each controller/system)	DPW	Laminated 11"x17"	1 ea
		Occupant Signage Sheets	DPW	Color printed labels	All
	X	Occupant Thermal Comfort Survey Data	DPW, PM	.xlsx	1
		Hand-Off Phase Training Agenda	RCx Team	.docx or .xlsx	1
			DPW, PM	CD	2
		Systems Manual (for each building)	DPW	3-ring binder	1 ea
	X	OCx Plan	RCx Team	.docx or .pdf	1
		Updated Issues & Resolution Log	RCx Team	.xlsx	1
	X	Seasonal Testing Data and Report	DPW, PM	.xlsx and .docx	1
OCx	X	Utilities Evaluation Data	DPW, PM	.xlsx	1
		CFR and OCx Plan Meeting Minutes	RCx Team	.docx or .pdf	1
		M&V and Endurance Test Data	DPW, PM	.xlsx	1
		Occupant Thermal Comfort Survey Data	DPW, PM	.xlsx	1
	X	Energy Audit ECM Table	DPW, PM	.xlsx	1
	X	Annual OCx Report	RCx Team	.docx or .pdf	1
			DPW	8.5"x11" (color)	2
	Updated Issues & Resolution Log	RCx Team	.xlsx	1	

## **10 Resources List**

At the time of publication, these RCx resources are available on a request basis through the CERL contact information listed in Appendix A.

### **10.1 RCx phases summary**

Slideshow overview of RCx phases including decisions, documentation, and deliverables associated with each phase.

### **10.2 CERL RCx field templates**

Spreadsheet templates for System Diagram Sheet, Issues and Resolutions Log, ECM Checklist, RCx Findings Sheet, Monitoring Plan Sheet, Functional Test Form, Preliminary ECM Table, and HVAC/ Excel® Cheat Sheets.

### **10.3 RCx Pre-assessment checklist**

Executable portable document format (PDF) used for site compilation of building documentation needed to support an RCx Assessment including a separate BAS Checklist.

### **10.4 Occupant thermal comfort survey**

Executable PDF used for site compilation of building documentation needed to support an RCx Assessment.

### **10.5 RCx SOW templates**

USACE scope of work standards for RCx Assessment and Investigation Phases with guidance for procuring additional RCx services.

### **10.6 RCx Contractor evaluation form**

Two-page evaluation form for RCx contractors to document RCx-related experience and qualifications as part of a bid submission.

### **10.7 Example RCx report**

CERL RCx of U.S. Army Garrison (USAG) Presidio Building 630 (Planning, Assessment, and Investigation Phases).

## **10.8 RCx planning workshop sample agenda**

Example list of topics to focus on for an RCx Planning Workshop that focuses on developing strategies, schedules, and roles for CEWE/RCx work.

## **10.9 Current facilities requirement (CFR) template**

Template for DPWs to complete building details, installation information, RCx goals, and preferred sequences of operation or other ECMs.

## **10.10 Retro-Commissioning University (RCxU) training checklist**

Links to training videos, exercises, and assessments associated with the Army RCx Practicum.

## **10.11 CERL RCx references table**

Spreadsheet table of links for approximately 200 relevant RCx references (organizational guides, tools, industry statistics, training programs, etc.).

## **Appendix A: Contact List**

U.S. Army Engineer Research and Development Center (ERDC)  
Construction Engineering Research Laboratory (CERL)  
ATTN: CEERD-CFE  
2902 Newmark Dr.  
Champaign, IL 61824

Brian C. Clark  
217-373-3338

Matt M. Swanson  
217-373-6788

Sean M. Wallace  
217-373-6511

Eileen T. Westervelt  
217-373-4530

## Acronyms and Abbreviations

<b>Term</b>	<b>Definition</b>
ACG	AABC Cx Group
AEE	Association of Energy Engineers
AHU	Air Handling Unit
AR	Army Regulation
ASHRAE	American Society of Heating, Refrigerating, and Air-Conditioning Engineers
BAS	Building Automation System
BCA	Building Commissioning Association
BCS	Building HVAC Controls System
BH	Brigade Headquarters
CAC	Common Access Card
CB ECS	Commercial Buildings Energy Consumption Survey
CC	Continuous Commissioning
CCR	Criteria Change Request
CDD	Total Cooling Degree Days
CERL	Construction Engineering Research Laboratory
CEWE	Comprehensive Energy and Water Evaluation
CFM	cubic feet per minute
CFR	Current Facilities Requirement
CO	carbon monoxide
CO <sub>2</sub>	Carbon dioxide
COF	Company Operations Facility
COV	Change of Value
DCV	Demand-Controlled Ventilation
DDC	Direct Digital Control
DFAC	Dining facility
DHW	Domestic Hot Water
DPW	Directorate of Public Works
DSIRE	Database of State Incentives for Renewables and Efficiency
DSP	Duct Static Pressure
EACA	Energy Awareness and Conservation Assessments
EAPP	Energy Engineering Analysis Program
EBCP	Existing Building Commissioning Professional
ECM	Energy Conservation Measure
EDG	Energy Design Guide
EISA	U.S. Energy Independence and Security Act of 2007
ERCIP	Energy Resilience & Conservation Investment Program
ERDC	U.S. Army Engineer Research and Development Center
ERDC-CERL	Engineer Research and Development Center, Construction Engineering Research Laboratory

<b>Term</b>	<b>Definition</b>
ESCO	Energy Services Contractor
ESPC	Energy Savings Performance Contract
EUI	Energy Use Index
FDD	Fault Detection Diagnostics
FEMP	Federal Energy Management Program
FY	Fiscal Year
HDD	Heating Degree Day
HOA	Hand-Off-Auto
HVAC	Heating, Ventilating, and Air-Conditioning
ID	Identification
IDIQ	Indefinite Delivery/Indefinite Quantity
IE&E	Office of the Assistant Secretary of the Army for Installations Energy and Environment
IESNA	Illuminating Engineering Society of North America
IMCOM	US Army Installation Management Command
IT	Information Technology
KSF	thousand square feet
LBL	Lawrence Berkeley National Laboratory
LED	Light Emitting Diode
LEED	Leadership in Energy and Environmental Design
M&V	Measurement and Verification
MAT	Mixed Air Temperature
MDMS	Meter Data Management System
MILCON	Military Construction
N/A	Not Applicable
NEBB	National Environmental Balancing Bureau
O&M	Operations and Maintenance
OA	Outside Air
OPR	Owner's Project Requirement
PC	Personal Computer
PDF	Portable Document Format
PG&E	Pacific Gas and Electric Company
PI	Principal Investigator
PNNL	Pacific Northwest National Laboratory
POC	Point of Contact
QUTM	Army funding code pertaining to sustainment, restoration and modernization management decision package for energy efficiency and utilities modernization
RCx	Retro-Commissioning or Recommissioning
RCxU	Retro-Commissioning University
REM	Resource Efficiency Manager
RH	Relative Humidity

---

<b>Term</b>	<b>Definition</b>
RMF	Risk Management Framework
ROI	Return on Investment
SAT	Supply Air Temperature
SDD	Sustainable Design and Development
SF	Square Foot/Square Feet
SOP	Standing Operating Procedure
SOW	Statement of Work
SRM	Sustainment, Restoration, and Modernization
TABB	Testing Adjusting and Balancing Bureau
TDY	temporary additional duty
TEMF	tactical equipment maintenance facilities
UEPH	Unaccompanied Enlisted Personnel Housing
UESC	Utility Energy Service Contract
UFC	Unified Facilities Criteria
UFGS	Unified Facilities Guide Specification
UMCS	Utility Monitoring and Control System
USACE	U.S. Army Corps of Engineers
USAG	U.S. Army Garrison
USDOE	U.S. Department of Energy
UW-M	University of Wisconsin-Madison
VAC	Volt AC
VAV	Variable Air Volume
VFD	Variable Frequency Drive
VNC	Virtual Network Connection
VPN	Virtual Private Network
WBDG	Whole Building Design Guide

# REPORT DOCUMENTATION PAGE

Form Approved  
OMB No. 0704-0188

Public reporting burden for this collection of information is estimated to average 1 hour per response, including the time for reviewing instructions, searching existing data sources, gathering and maintaining the data needed, and completing and reviewing this collection of information. Send comments regarding this burden estimate or any other aspect of this collection of information, including suggestions for reducing this burden to Department of Defense, Washington Headquarters Services, Directorate for Information Operations and Reports (0704-0188), 1215 Jefferson Davis Highway, Suite 1204, Arlington, VA 22202-4302. Respondents should be aware that notwithstanding any other provision of law, no person shall be subject to any penalty for failing to comply with a collection of information if it does not display a currently valid OMB control number. PLEASE DO NOT RETURN YOUR FORM TO THE ABOVE ADDRESS.

<b>1. REPORT DATE (DD-MM-YYYY)</b> 01/31/2018			<b>2. REPORT TYPE</b> Final		<b>3. DATES COVERED (From - To)</b>	
<b>4. TITLE AND SUBTITLE</b> Army RCx Technical Guide: A Phased Approach for in-House or Contracted Existing Building Commissioning					<b>5a. CONTRACT NUMBER</b>	
					<b>5b. GRANT NUMBER</b>	
					<b>5c. PROGRAM ELEMENT</b>	
<b>6. AUTHOR(S)</b> Brian C. Clark, Matt M. Swanson, Sean M. Wallace, Eileen T. Westervelt, and Jay H. Tulley					<b>5d. PROJECT NUMBER</b> MIPR 10937859	
					<b>5e. TASK NUMBER</b>	
					<b>5f. WORK UNIT NUMBER</b>	
<b>7. PERFORMING ORGANIZATION NAME(S) AND ADDRESS(ES)</b> U.S. Army Engineer Research and Development Center (ERDC) Construction Engineering Research Laboratory (CERL) PO Box 9005, Champaign, IL 61826-9005					<b>8. PERFORMING ORGANIZATION REPORT NUMBER</b>  ERDC/CERL SR-18-1	
<b>9. SPONSORING / MONITORING AGENCY NAME(S) AND ADDRESS(ES)</b> Office of the Assistant Secretary of the Army for Installations, Energy and Environment (ASA[IE&E]) 110 Army Pentagon Room 3D453 Washington, DC 20310-0110					<b>10. SPONSOR/MONITOR'S ACRONYM(S)</b> ASA(IE&E)	
					<b>11. SPONSOR/MONITOR'S REPORT NUMBER(S)</b>	
<b>12. DISTRIBUTION / AVAILABILITY STATEMENT</b> Approved for public release; distribution is unlimited.						
<b>13. SUPPLEMENTARY NOTES</b>						
<b>14. ABSTRACT</b> RCx (retro-commissioning and recommissioning) is a method that combines knowledge of heating, ventilating, and air-Conditioning (HVAC) fundamentals with specific testing and analysis techniques to optimize facility energy systems and solve comfort and operations and maintenance (O&M) problems. RCx uses instrumentation and automation systems to “talk” to the facility to determine how the system is operating and how it can operate better. RCx is Congressionally mandated at specific federal facilities and is regarded by industry as a next-generation building energy management system. Yet, performing, developing, or managing successful RCx projects can be a complex process that requires facilities staff to acquire technical and soft skillsets to identify, implement, and sustain often hidden opportunities. This RCx Technical Guide uses the latest industry guidelines, standards, and studies to present “how-to” instructions for Directorate of Public Works (DPW) personnel that break RCx into discrete phases that can be contracted or performed in-house in various combinations, to map resilient RCx programs across different sized and staffed asset management organizations. This technical walk-through of each RCx phase encountered in a typical RCx event is a vital part of the personnel development needed as facilities grow more complex and as staffing challenges continue.						
<b>15. SUBJECT TERMS</b> Energy consumption, Facility management, Buildings--Energy conservation, Buildings--Retrofitting, Military bases						
<b>16. SECURITY CLASSIFICATION OF:</b>			<b>17. LIMITATION OF ABSTRACT</b>  SAR	<b>18. NUMBER OF PAGES</b>  94	<b>19a. NAME OF RESPONSIBLE PERSON</b>	
<b>a. REPORT</b> Unclassified	<b>b. ABSTRACT</b> Unclassified	<b>c. THIS PAGE</b> Unclassified			<b>19b. TELEPHONE NUMBER (include area code)</b>	