

AWARD NUMBER: W81XWH-17-1-0287

TITLE:

Multi-parametric Bioreactor for Functional Preservation of Vascularized Composite Allografts

PRINCIPAL INVESTIGATOR: Gerald Brandacher, MD

**RECIPIENT: Johns Hopkins University
BALTIMORE MD 21218**

REPORT DATE: October 2018

TYPE OF REPORT: Annual Report

**PREPARED FOR: U.S. Army Medical Research and Materiel Command
Fort Detrick, Maryland 21702-5012**

DISTRIBUTION STATEMENT: Approved for public release. Distribution unlimited.

The views, opinions and/or findings contained in this report are those of the author(s) and should not be construed as an official Department of the Army position, policy or decision unless so designated by other documentation.

REPORT DOCUMENTATION PAGE			<i>Form Approved</i> OMB No. 0704-0188		
Public reporting burden for this collection of information is estimated to average 1 hour per response, including the time for reviewing instructions, searching existing data sources, gathering and maintaining the data needed, and completing and reviewing this collection of information. Send comments regarding this burden estimate or any other aspect of this collection of information, including suggestions for reducing this burden to Department of Defense, Washington Headquarters Services, Directorate for Information Operations and Reports (0704-0188), 1215 Jefferson Davis Highway, Suite 1204, Arlington, VA 22202-4302. Respondents should be aware that notwithstanding any other provision of law, no person shall be subject to any penalty for failing to comply with a collection of information if it does not display a currently valid OMB control number. PLEASE DO NOT RETURN YOUR FORM TO THE ABOVE ADDRESS.					
1. REPORT DATE (DD-MM-YYYY) October 2018		2. REPORT TYPE Annual		3. DATES COVERED (From - To) 30 Sep 2017 - 29 Sep 2018	
4. TITLE AND SUBTITLE Multi-parametric Bioreactor for Functional Preservation of Vascularized Composite Allografts			5a. CONTRACT NUMBER		
			5b. GRANT NUMBER W81XWH-17-1-0287		
			5c. PROGRAM ELEMENT NUMBER		
6. AUTHOR(S) Gerald Brandacher, MD email: gbranda2@johnshopkins.edu			5d. PROJECT NUMBER		
			5e. TASK NUMBER		
			5f. WORK UNIT NUMBER		
7. PERFORMING ORGANIZATION NAME(S) AND ADDRESS(ES) JOHNS HOPKINS UNIVERSITY, THE 3400 N CHARLES ST W400 WYMAN PARK BLDG BALTIMORE MD 21218			8. PERFORMING ORGANIZATION REPORT NUMBER		
9. SPONSORING / MONITORING AGENCY NAME(S) AND ADDRESS(ES) U.S. Army Medical Research and Materiel Command Fort Detrick, Maryland 21702-5012			10. SPONSOR/MONITOR'S ACRONYM(S)		
			11. SPONSOR/MONITOR'S REPORT NUMBER(S)		
12. DISTRIBUTION / AVAILABILITY STATEMENT Approved for public release. Distribution unlimited.					
13. SUPPLEMENTARY NOTES					
14. ABSTRACT 1. More than half of the combat-related injuries per peer reviewed analyses of the Joint Theater Trauma Registry sustained by Warfighters in Iraq and Afghanistan involved extremities or craniofacial structures. An estimated 40% of all combat casualties in Operation Enduring Freedom (OEF) and Operation Iraqi Freedom (OIF) resulted in injuries to the extremities, face, and head and neck structures. Vascularized composite allotransplantation has increasingly become a viable clinical treatment option for the treatment of complex craniofacial and limb defects. To date, more than 100 patients worldwide have benefited from VCA, the majority receiving hand or face transplants. However, the transformational potential of VCA is severely limited by short preservation times (4 – 6 hours) 2. . This work will deliver ex vivo VCA perfusion technology intended to extend preservation time to 24 hours and minimize ischemia damage by efficient perfusion and multi-parametric monitoring.					
15. SUBJECT TERMS VCA preservation, electrical stimulation, biosensor					
16. SECURITY CLASSIFICATION OF:			17. LIMITATION OF ABSTRACT	18. NUMBER OF PAGES	19a. NAME OF RESPONSIBLE PERSON
a. REPORT	b. ABSTRACT	c. THIS PAGE			Gerald Brandacher, MD
Unclassified	Unclassified	Unclassified	Unclassified	23	19b. TELEPHONE NUMBER (include area code)

TABLE OF CONTENTS

	<u>Page No.</u>
1. Introduction	4
2. Keywords	4
3. Accomplishments	5
4. Impact	15
5. Changes/Problems	17
6. Products	18
7. Participants & Other Collaborating Organizations	20
8. Special Reporting Requirements	22
9. Appendices	23

1. **INTRODUCTION:** Narrative that briefly (one paragraph) describes the subject, purpose and scope of the research.

Background. More than half of the combat-related injuries per peer reviewed analyses of the Joint Theater Trauma Registry sustained by Warfighters in Iraq and Afghanistan involved extremities or craniofacial structures. An estimated 40% of all combat casualties in Operation Enduring Freedom (OEF) and Operation Iraqi Freedom (OIF) resulted in injuries to the extremities, face, and head and neck structures. Vascularized composite allotransplantation has increasingly become a viable clinical treatment option for the treatment of complex craniofacial and limb defects. To date, more than 100 patients worldwide have benefited from VCA, the majority receiving hand or face transplants. However, the transformational potential of VCA is severely limited by short preservation times (4 – 6 hours) and all the logistical difficulties that come with this limitation. VCA survival is highly dependent on the ischemia injury happening during preservation. Consequently, organ preservation plays a major role in improving the clinical outcome of transplantation. Extracorporeal perfusion systems have demonstrated superior preservation outcome in different solid organs comparing to cold storage. Therefore there is critical need for developing preservation technology based on ex-vivo perfusion to enhance VCA preservation.

Objective/Hypothesis. This work will deliver ex vivo VCA perfusion technology intended to extend preservation time to 24 hours and minimize ischemia damage by efficient perfusion and multi-parametric monitoring.

Specific Aims.

Specific Aim 1. Engineer multi-parametric bioreactor system designed for preservation and real-time monitoring of NO/ROS in rat abdominal wall VCA. We designed stand-alone perfusion/electrical stimulation system maintaining viability of rat abdominal wall.

Specific Aim 2. Preserve viability and function of abdominal wall VCA up to 72 hours in bioreactor and establish the viability biomarker profile. We will develop ES protocol to enhance abdominal wall VCA preservation.

Specific Aim 3. Preserve whole extremity VCA in bioreactor and assess post-transplant viability and function. A new multi-parametric bioreactor will be designed based on the knowledge of bioreactor design we gain from the first aim and will preserve rat forelimb VCA for longer than 24 hours.

2. **KEYWORDS:** Provide a brief list of keywords (limit to 20 words).

Vascularized composite allograft, ex-vivo perfusion, biosensor, electrical stimulation, rat abdominal wall

3. **ACCOMPLISHMENTS:** The PI is reminded that the recipient organization is required to obtain prior written approval from the awarding agency Grants Officer whenever there are significant changes in the project or its direction.

What were the major goals of the project? *List the major goals of the project as stated in the approved SOW. If the application listed milestones/target dates for important activities or phases of the project, identify these dates and show actual completion dates or the percentage of completion.*

Specific Aim 1	Timeline	Progress
Major Task 1: Engineer multi-parametric bioreactor system designed for preservation and real-time monitoring of NO/ROS in rat abdominal wall VCA.	Months	
Task 1A: Design stand-alone perfusion/electrical stimulation system maintaining viability of rat abdominal wall	1-12	100%
Task 1B: Develop in-line sensors to measure concentrations of NO and ROS for non-invasive, real-time graft monitoring.	1-18	30%
Milestone(s) Achieved: ACURO approval for studies in Aims 2 & 3.		
Specific Aim 2		
Major Task 2: Evaluation of scaffold technology for orbital bone reconstruction.		
Task 2A: Optimize ES protocol to enhance abdominal wall VCA preservation.	6-18	10%
Task 2B: Preserve abdominal wall VCA for up to 72 hours through perfusion and ES. Utilize non-invasive measurements to establish a 'viability biomarker profile' and correlate with post-transplant viability.	6 – 24	25%
Milestone(s) Achieved:		
Specific Aim 3		
Major Task 3: Preserve whole extremity VCA in bioreactor and assess post-transplant viability and function.		
Task 3A: Re-design multi-parametric bioreactor to provide ES of the flexor and extensors forearm muscles of the rodent upper extremity transplant.	18 – 24	0%
Task 3B: Preserve rat forelimb VCA in bioreactor for 24 – 72 hours post-procurement. Assess ischemia-reperfusion injury, graft viability, and long-term function following bioreactor preservation.	18 - 36	0%
Milestone(s) Achieved:		

What was accomplished under these goals?

For this reporting period describe: 1) major activities; 2) specific objectives; 3) significant results or key outcomes, including major findings, developments, or conclusions (both positive and negative); and/or 4) other achievements. Include a discussion of stated goals not met. Description shall include pertinent data and graphs in sufficient detail to explain any significant results achieved. A succinct description of the methodology used shall be provided. As the project progresses to completion, the emphasis in reporting in this section should shift from reporting activities to reporting accomplishments.

Major activities:

We designed and built a bioreactor chamber to preserve the abdominal wall graft in a sterile, humid environment while being connected to the perfusion system and electrical stimulation. In **Figure 1** the images of Solidwork design and the final bioreactor are shown. This design provides both inlets and outlets for the perfusate, a way of electrically stimulating the tissue, a mounting mechanism for the force sensor, and a drainage reservoir for the perfusate. There are four removable panels that allow for quick and easy access to the inner parts of the bioreactor after assembly has been completed.

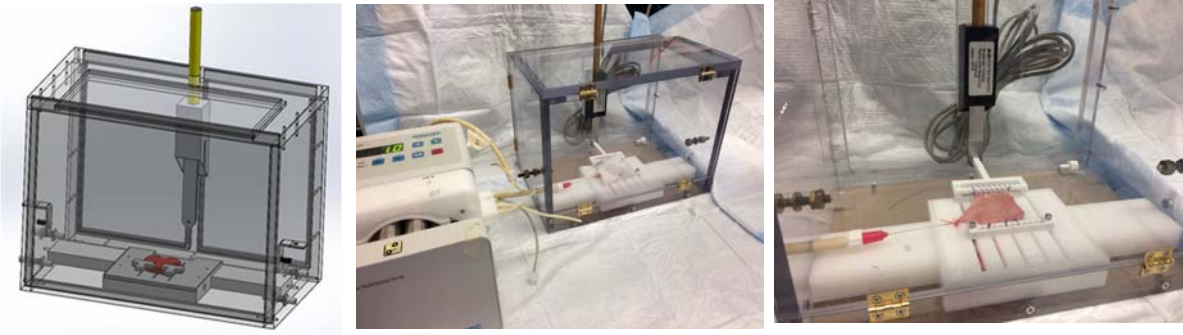

Figure 1. SolidWorks design of the bioreactor and final bioreactor.

The general layout of the perfusion system is shown in **Figure 2** including filters, oxygenator, heater, sensors and controller. Pressure, temperature, pH and oxygen sensors have been purchased and implemented in perfusion line as it is shown in **Figure 3**. The sensors monitor perfusion during 12 hours of abdominal wall perfusion (**Figure 3.B**).

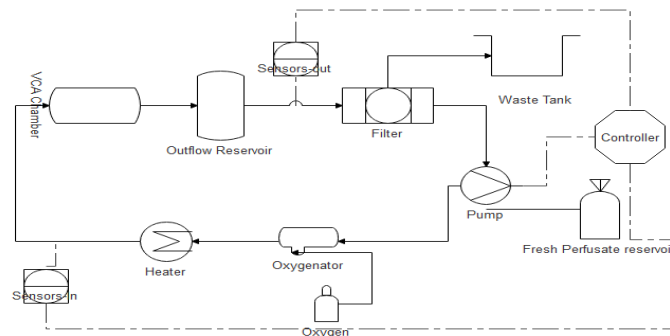

Figure 2. General Layout of Perfusion Loop

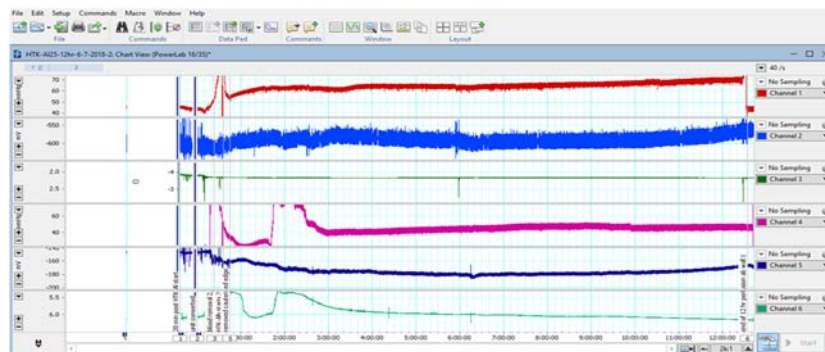

Figure 3: Pressure, Oxygen and pH monitoring of Two Abdominal Wall Perfusion Systems Subtask 1.2: Develop in-line sensors to measure concentrations of NO and ROS for non-invasive, real-time graft monitoring.

We have fabricated a W-wire gold nanoparticle modified electrode that can detect the presence of reactive oxygen species, H_2O_2 with a linear dynamic range of 800 pM to 5 mM. The gold nanoparticle was electrochemically deposited over the W-wire electrode followed by surface modification with mercaptopropionic acid. The surface of the electrode was subsequently functionalized with horseradish peroxidase (HRP) as the biorecognition element via EDC/NHS coupling to enable the detection of H_2O_2 via reduction by the immobilized HRP catalyst. The W-AuNP-HRP modified electrode was finally coated with 1% chitosan. **Figure 4 (C-F)** shows the calibration curve of the sensor for different concentration ranges. The reduction currents of H_2O_2 at the modified electrode were proportional to the concentration of H_2O_2 in the range of 800pM to 5mM with a correlation coefficient of 0.99X (X=9 or 8), and a sensitivity of with a sensitivity of 0.129 mA /mM cm^2 . The wide linear range covers the physiological concentration for H_2O_2 .

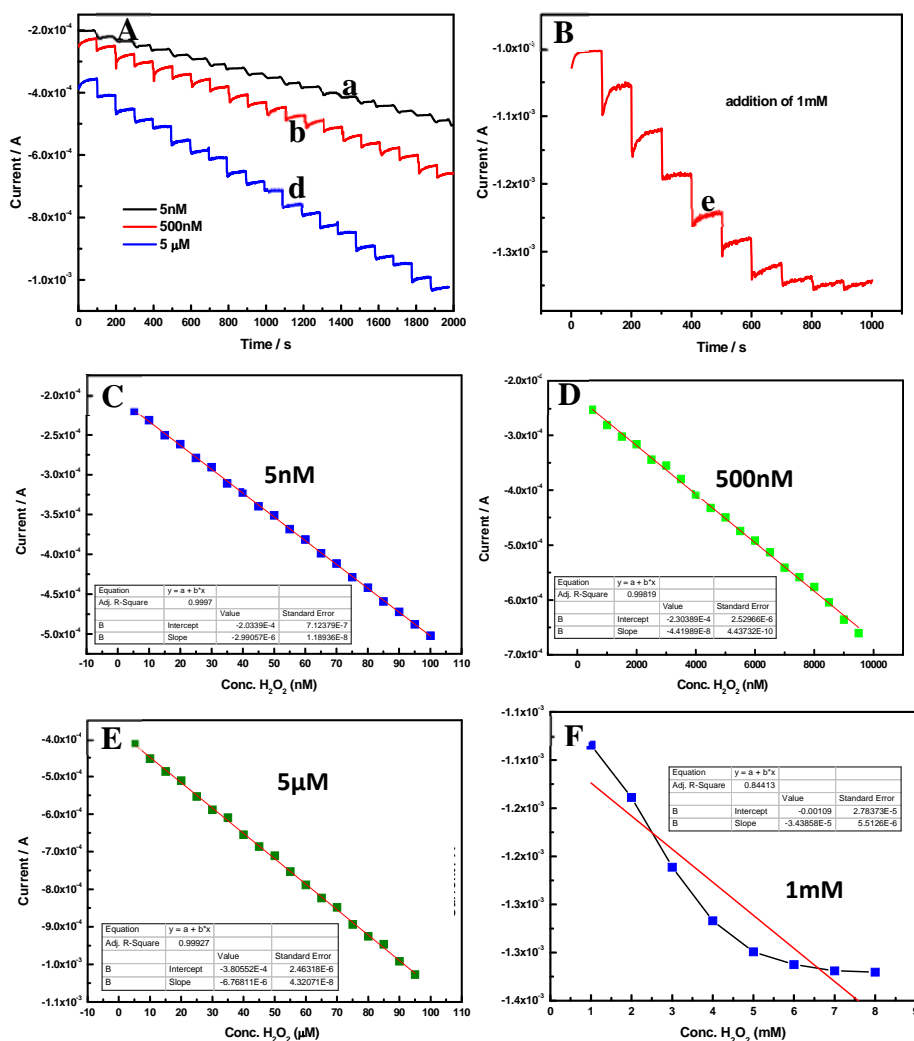

Figure 4. Steady-state current – time responses obtained by W-AuNP-HRP electrode to various concentrations of H_2O_2 in 20 mM PBS (A) a) 5 nM b) 500 nM, and c) 5 μM and (B) 1 mM series additions. Corresponding calibration curve for H_2O_2 concentrations (C) 5 nM, (D) 500 nM, (E) 5 μM and (F) 1 mM.

Figure 5 shows the stability of the WAuNp-HRP electrode measured over a period of 8 days. We have used the same electrode and measured the CV in the presence of 100nM H₂O₂ for eight consecutive days.

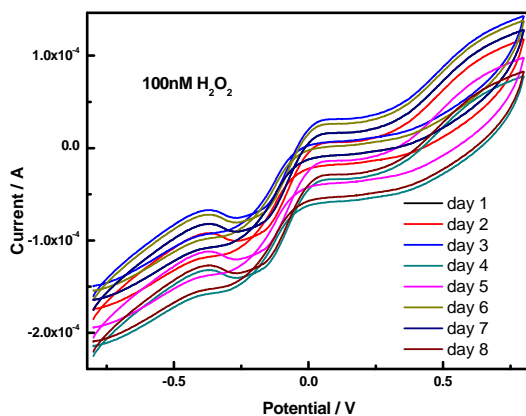

Figure 5: Stability measurement

The selectivity measurement was done in the presence of different interfering species which may contribute/affect the sensors performance. For which, we have chosen to use ascorbic acid, uric acid, acetaminophen and glucose. As seen in **Figure 7**, the amperometric reduction current increased only for the addition of 1 mM H₂O₂ and not for the other species, which increases the selectivity of the WAuNp-HRP electrode towards H₂O₂.

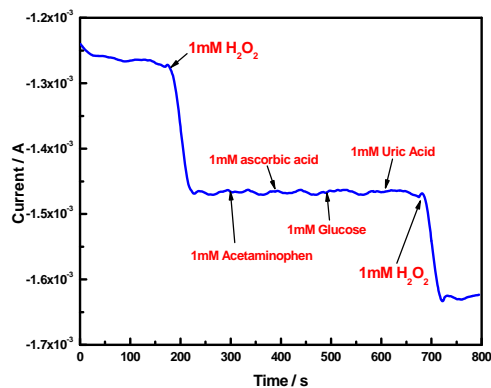

Figure 7: Selectivity measurement

We designed and developed an in-line dual analyte biosensor for the simultaneous determination of H₂O₂ and glucose. The in-line biosensor is 15 mm long with two 0.7 mm hollow cores in the center for holding the common reference and counter electrode, and for the working electrode in the outer stock (**Figure 8A & B**). A clear cross-sectional view of the designed in-line biosensor configuration is shown in **Figure 8C**, where the outer ring protects the electrode from damage. All the four working electrodes can be placed in north, east, west and south side of the inner tube, while the reference and counter electrodes are placed in the center core.

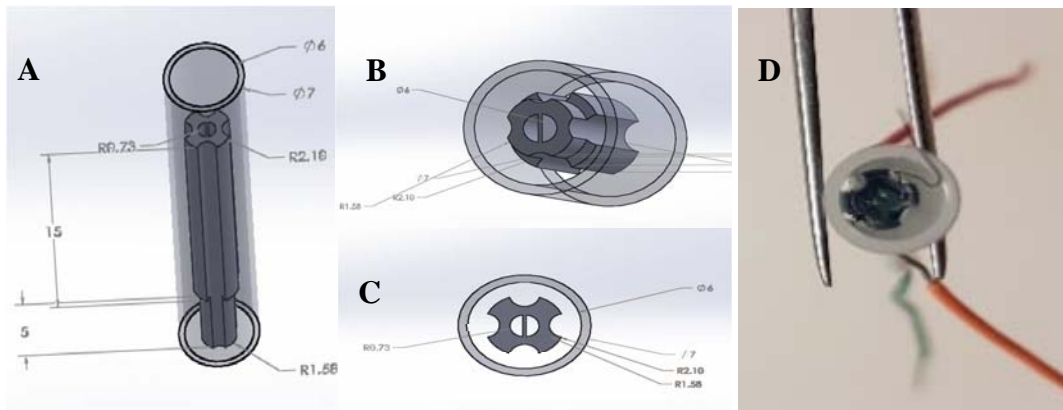

Figure 8 A-C Design of in-line multi-analyte biosensor. D cross-sectional view of the designed in-line biosensor

In addition, we have fabricated a 20 mm long Ag/AgCl reference electrode and a 20 mm long platinum wire was used as a counter electrode. Working electrodes for the detection of glucose and H_2O_2 were separately made over a gold-tungsten wire.

The electrochemical behavior of the integrated electrodes is shown in **Figure 9**. A bi-potentiostat was used measure the cyclic voltammetry (CV) response. The CV measurements were carried out in a potential window of -1400 to +1400 mV. The black lines in the CV curve (**Figure 9**) are used for the glucose sensing behavior in the Pt modified Au wire electrode and the red lines are used for H_2O_2 sensing behavior in AuNP-HRP modified tungsten electrode. Curve a and b shows the electrodes response in 10 mM PBS and curve a' and b' shows the respective electrodes response in the presence of 1 mM Glucose and 100 μM H_2O_2 in 10 mM PBS.

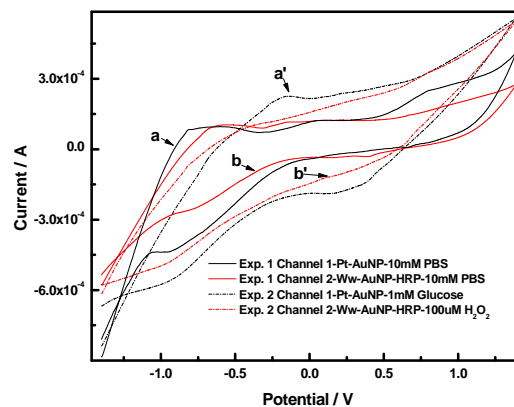

Figure 9: Electrochemical dual sensing behavior of the integrated electrodes

A clear glucose oxidation peak (curve a') at -150 mV and a H_2O_2 reduction peak at (curve b') - 950 mV were observed. These peaks are not observable in curve a and b, without glucose and H_2O_2 . It is to note that the solution used in the experiment 2 (i.e. curve a' and b') contains the

mixture of 1 mM glucose and 1 μ M H₂O₂ in 10 mM PBS, respectively. Clearly, the dual biosensor is capable of discriminating glucose and H₂O₂ simultaneously.

Subtask 2.1: Optimize ES protocol to enhance abdominal wall VCA preservation.

The circuit for the electrical stimulation system has been designed and tested. A prototype of the electrical stimulation has been used to electrically stimulate the harvested rat abdominal wall. Upon stimulation, the rat abdominal wall is able to contract. The initial set up for the electrical stimulation and its circuit can be seen within **Figure 10**. The setup includes a power supply, an Arduino microcontroller, a laptop to control the Arduino board, the stimulation circuit, and a pair of platinum electrodes.

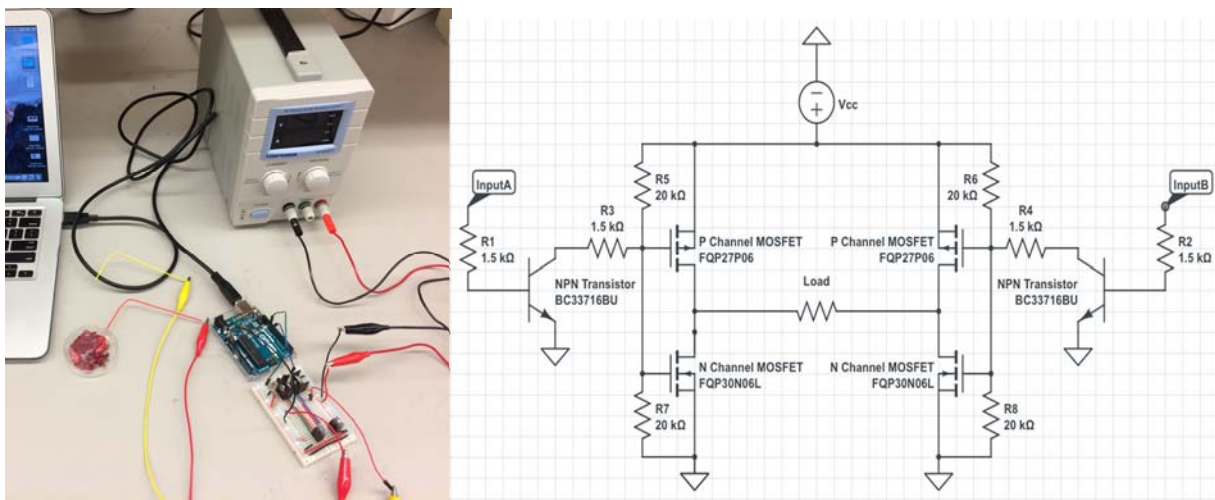

Figure 10. Electrical Stimulation Set Up and Circuit

Subtask 2.2: Preserve abdominal wall VCA for up to 72 hours through perfusion and ES. Utilize non-invasive measurements to establish a ‘viability biomarker profile’ and correlate with post-transplant viability

The abdominal wall transplant model is based on the procedure previously described by Broyles (Broyles, 2015). Some modifications were made to the procedure in order to adapt this transplantation model to the current project. The most notable changes were decreasing graft size to maximize perfusion to the graft and preserving the superficial epigastric vessels (SEV) to ensure the viability of the skin and fat layer. In addition, we apply a bandage to the surgical site during the early post-transplant period to prevent auto-mutilation of the graft.

Figure 11 illustrates the importance of preserving the SEV in order to ensure viability of all graft components including the skin

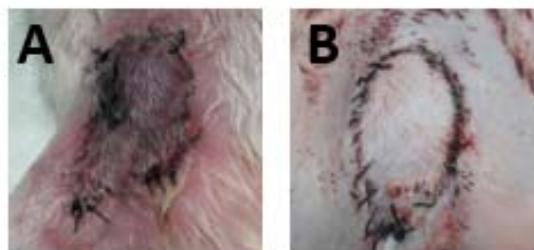

Figure 11. A) Transplant on POD2 without SEV B) Transplant on POD2 with preserved SEV

By implementing these changes, we have thus far been able to successfully transplant the abdominal wall in three recipient animals, as shown in Figure 2. Continued efforts will be made to ensure the extended survival of the abdominal grafts and the reproducibility of the procedure.



Figure 12. A) Successful transplant attempt #1 on POD3 B) Successful transplant attempt #2 on POD3 C) Successful transplant attempt #3 on POD5

Four additional syngeneic abdominal wall transplants were attempted in order to ensure extended graft survival. However, we found that the bandage was insufficient to prevent autotomy of the graft. The rats tended to remove the bandage and damage the graft, as seen in **Figure 13A**. In one case, the animal auto-mutilated the graft on POD35, which was unexpected so far out into recovery. This led us to implement Elizabethan collars to better prevent surgical site access and provide more comfort and ease of movement. With this collar, we successfully completed a transplant that is currently healthy. This transplanted graft was larger than previous attempts, approximately 4x4cm as compared to 2.5x3cm. We were able to confirm that the preserved superficial epigastric vessels are sufficient to maintain a larger area of skin. **Figure 13B** shows this transplant on POD35. Biopsies were taken at POD19 and 35 and will be analyzed with H&E to establish a histologic baseline for syngeneic transplants.

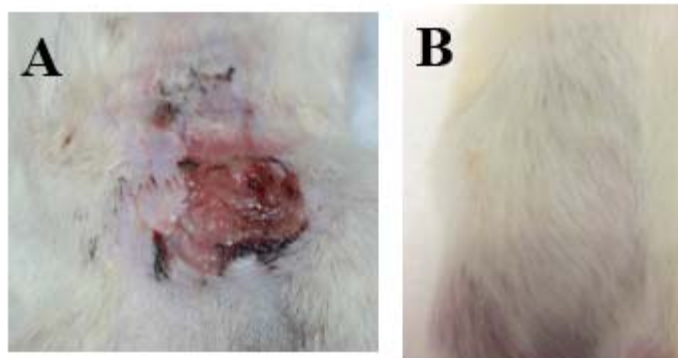

Figure 13. A) Damaged transplanted graft on POD12 B) Larger, healthy transplanted graft on POD35

Several experiments have been done with euthanasia rats to develop the basics of rat abdominal wall ex-vivo perfusion system. Abdominal wall grafts were connected to the perfusion system with peristaltic pump set at 0.5 ml/min to get perfused for 12 hours at room temperature after flushing the blood out. Tissue viability (based on necrosis score from H&E staining) and weight gain were used to assess the efficiency of the perfusion. The main issue appeared to be high weight gain which is indicative of high edema during perfusion.

Three incremental changes have been made to decrease the tissue swelling. First was to cut the cauterized tissue from the surrounding of muscle which could help the perfusate to diffuse out of the graft. Second was to raise the oncotic pressure by Albumin addition to the perfusate based on Starling law to draw more perfusate form interstitial apace. Third was to implement intermittent perfusion rather than continuous perfusion. All of the three changes demonstrated improvement in reduction of tissue swelling.

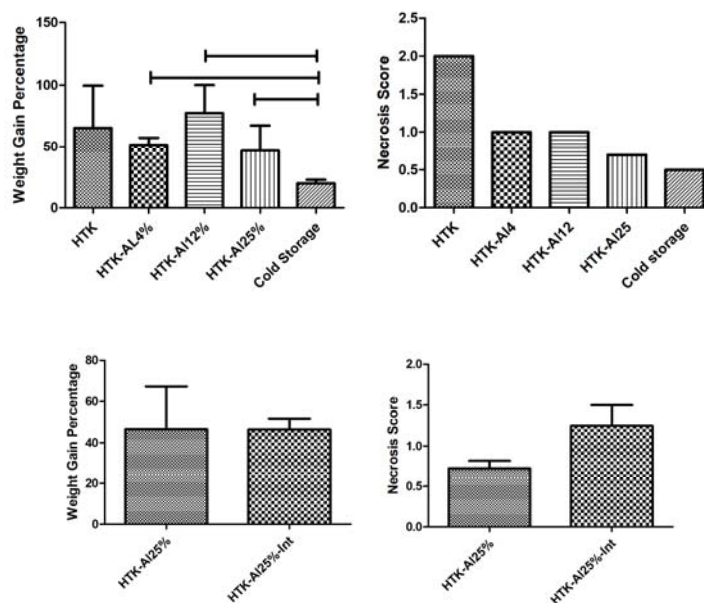

Figure 14. The necrosis score is obtained by percentage of myofibers showing at least of the four main attributes of necrotic myofiber in H&E staining. Necrosis score and weight gain percent of a) albumin and HTK perfusion b) continuous and intermittent perfusion.

*Discussion of stated goals not met **These goals have been partially met due to delays in obtaining the IACUC and the subsequent ACURO approvals as well as due to delays in IRB approvals for the SVF isolation. However, we have since secured approvals for all of these elements and expect to achieve those goals over the next several months.***

There have been some other delays due to changes in plans discussed in more detail in Section 5 below.

What opportunities for training and professional development has the project provided?

If the project was not intended to provide training and professional development opportunities or there is nothing significant to report during this reporting period, state “Nothing to Report.”

Describe opportunities for training and professional development provided to anyone who worked on the project or anyone who was involved in the activities supported by the project. “Training” activities are those in which individuals with advanced professional skills and experience assist others in attaining greater proficiency. Training activities may include, for example, courses or one-on-one work with a mentor. “Professional development” activities result in increased knowledge or skill in one’s area of expertise and may include workshops, conferences, seminars, study groups, and individual study. Include participation in conferences, workshops, and seminars not listed under major activities.

Courses: Sara Salehi is currently taking the course of The Principle of Design of Biomedical Instrumentation.

One-on-one work with mentor: has 2 one-on-one meetings each year with Sara Salehi and Kenny Tran to discuss project related elements as well as all other factors related to professional development.

Weekly or bi-weekly meetings: Initially Dr. Grayson has had weekly meeting with Sara Salehi and Kenny Tran to discuss detailed plan of building the ex-vivo perfusion system but as the system began working the meeting happened bi-weekly.

Monthly Meeting : The progress made by each Dr. Grayson, Brandacher and Slaughter labs has been discussed every month with everyone working on the project.

Meetings with clinicians: Sara Salehi and Vanessa have had monthly meetings with Dr. Brandacher to discuss issues with VCA procurement and transplantation surgery.

Conferences: Sara Salehi attended and presented a poster at Organ Banking Summit in August 2017 and will attend and present another poster at American Society For Reconstructive Transplantation Biennial Meeting in November 2018.

How were the results disseminated to communities of interest?

If there is nothing significant to report during this reporting period, state “Nothing to Report.”

Describe how the results were disseminated to communities of interest. Include any outreach activities that were undertaken to reach members of communities who are not usually aware of these project activities, for the purpose of enhancing public understanding and increasing interest in learning and careers in science, technology, and the humanities.

Nothing to report

What do you plan to do during the next reporting period to accomplish the goals?

If this is the final report, state “Nothing to Report.”

Describe briefly what you plan to do during the next reporting period to accomplish the goals and objectives.

Acquisition of oxygenator and heat exchanger
Adding concentrated hemoglobin to the perfusate
Incorporate the biosensor into the sensors' unit of the perfusion system
Design a system to control the perfusion with feedback received from sensors

4. IMPACT: Describe distinctive contributions, major accomplishments, innovations, successes, or any change in practice or behavior that has come about as a result of the project relative to:

What was the impact on the development of the principal discipline(s) of the project?

If there is nothing significant to report during this reporting period, state “Nothing to Report.”

Describe how findings, results, techniques that were developed or extended, or other products from the project made an impact or are likely to make an impact on the base of knowledge, theory, and research in the principal disciplinary field(s) of the project. Summarize using language that an intelligent lay audience can understand (Scientific American style).

Nothing to Report.

What was the impact on other disciplines?

If there is nothing significant to report during this reporting period, state “Nothing to Report.”

Describe how the findings, results, or techniques that were developed or improved, or other products from the project made an impact or are likely to make an impact on other disciplines.

Nothing to Report.

What was the impact on technology transfer?

If there is nothing significant to report during this reporting period, state “Nothing to Report.”

Describe ways in which the project made an impact, or is likely to make an impact, on commercial technology or public use, including:

- *transfer of results to entities in government or industry;*
- *instances where the research has led to the initiation of a start-up company; or*
- *adoption of new practices.*

Nothing to Report.

What was the impact on society beyond science and technology?

If there is nothing significant to report during this reporting period, state “Nothing to Report.”

Describe how results from the project made an impact, or are likely to make an impact, beyond the bounds of science, engineering, and the academic world on areas such as:

- *improving public knowledge, attitudes, skills, and abilities;*
- *changing behavior, practices, decision making, policies (including regulatory policies), or social actions; or*
- *improving social, economic, civic, or environmental conditions.*

Nothing to Report.

5. CHANGES/PROBLEMS: The Project Director/Principal Investigator (PD/PI) is reminded that the recipient organization is required to obtain prior written approval from the awarding agency Grants Officer whenever there are significant changes in the project or its direction. If not previously reported in writing, provide the following additional information or state, “Nothing to Report,” if applicable:

Changes in approach and reasons for change

Describe any changes in approach during the reporting period and reasons for these changes. Remember that significant changes in objectives and scope require prior approval of the agency.

Nothing to Report

Actual or anticipated problems or delays and actions or plans to resolve them

Describe problems or delays encountered during the reporting period and actions or plans to resolve them.

- We need the platinum coated silicone tubing for the perfusion system to prevent biofouling in the system because of hemoglobin in the perfusion. Due to worldwide shortage on silicone we have been told to expect 3-5 month lead time. We have already placed the order and while waiting for the tubing we will be working on optimizing other factors of the perfusion system.
- Setting up the controller for the perfusion system requires a custom designed model that receives feedback from our sensors and communicate with the pump. We will start with incorporating one biosensor to the current monitoring system and develop the model for the current sensors so we can advance it when we have all the sensors ready to use.

Changes that had a significant impact on expenditures

Describe changes during the reporting period that may have had a significant impact on expenditures, for example, delays in hiring staff or favorable developments that enable meeting objectives at less cost than anticipated.

In order to reduce the number of donor rats, we need to procure two abdominal wall graft from a rat. Therefore, another bioreactor is needed. As the sensors were bought in pairs, initially we can have two set of sensors monitoring inlet to the bioreactor.

Significant changes in use or care of human subjects, vertebrate animals, biohazards, and/or select agents

Describe significant deviations, unexpected outcomes, or changes in approved protocols for the use or care of human subjects, vertebrate animals, biohazards, and/or select agents during the reporting period. If required, were these changes approved by the applicable institution committee (or equivalent) and reported to the agency? Also specify the applicable Institutional Review Board/Institutional Animal Care and Use Committee approval dates.

Significant changes in use or care of human subjects

Nothing to report

Significant changes in use or care of vertebrate animals.

We propose to change the pig study to a facility at Louisiana State University, which has experience with pig model of craniomaxillofacial bone defects. These changes have been outlined in the proposed changes to the SOW.

Significant changes in use of biohazards and/or select agents

Nothing to report

5. **PRODUCTS:** List any products resulting from the project during the reporting period. If there is nothing to report under a particular item, state “Nothing to Report.”

- **Publications, conference papers, and presentations**

Report only the major publication(s) resulting from the work under this award.

Journal publications. *List peer-reviewed articles or papers appearing in scientific, technical, or professional journals. Identify for each publication: Author(s); title; journal; volume: year; page numbers; status of publication (published; accepted, awaiting publication; submitted, under review; other); acknowledgement of federal support (yes/no).*

Nothing to report

Books or other non-periodical, one-time publications. *Report any book, monograph, dissertation, abstract, or the like published as or in a separate publication, rather than a periodical or series. Include any significant publication in the proceedings of a one-time conference or in the report of a one-time study, commission, or the like. Identify for each one-time publication: Author(s); title; editor; title of collection, if applicable; bibliographic information; year; type of publication (e.g., book, thesis or dissertation); status of publication (published; accepted, awaiting publication; submitted, under review; other); acknowledgement of federal support (yes/no).*

“Establishing a Rat Abdominal Wall Perfusion Model for VCA Preservation”, Organ Banking Summit, 3rd-6th August 2017

Other publications, conference papers, and presentations. *Identify any other publications, conference papers and/or presentations not reported above. Specify the status of the publication as noted above. List presentations made during the last year (international, national, local societies, military meetings, etc.). Use an asterisk (*) if presentation produced a manuscript.*

Nothing to report

- **Website(s) or other Internet site(s)**

List the URL for any Internet site(s) that disseminates the results of the research activities. A short description of each site should be provided. It is not necessary to include the publications already specified above in this section.

Nothing to report

- **Technologies or techniques**

Identify technologies or techniques that resulted from the research activities. In addition to a description of the technologies or techniques, describe how they will be shared.

Nothing to report

- **Inventions, patent applications, and/or licenses**

Identify inventions, patent applications with date, and/or licenses that have resulted from the research. State whether an application is provisional or non-provisional and indicate the application number. Submission of this information as part of an interim research performance progress report is not a substitute for any other invention reporting required under the terms and conditions of an award.

Nothing to report

- **Other Products**

Identify any other reportable outcomes that were developed under this project. Reportable outcomes are defined as a research result that is or relates to a product, scientific advance, or research tool that makes a meaningful contribution toward the understanding, prevention, diagnosis, prognosis, treatment, and/or rehabilitation of a disease, injury or condition, or to improve the quality of life. Examples include:

- *data or databases;*
- *biospecimen collections;*
- *audio or video products;*
- *software;*
- *models;*
- *educational aids or curricula;*
- *instruments or equipment;*
- *research material (e.g., Germplasm; cell lines, DNA probes, animal models);*
- *clinical interventions;*
- *new business creation; and*
- *other.*

Nothing to report

6. PARTICIPANTS & OTHER COLLABORATING ORGANIZATIONS

What individuals have worked on the project?

Provide the following information for: (1) PDs/PIs; and (2) each person who has worked at least one person month per year on the project during the reporting period, regardless of the source of compensation (a person month equals approximately 160 hours of effort). If information is unchanged from a previous submission, provide the name only and indicate “no change.”

Example:

Name: Mary Smith
Project Role: Graduate Student
Researcher Identifier (e.g. ORCID ID): 1234567
Nearest person month worked: 5
Contribution to Project: Ms. Smith has performed work in the area of combined error-control and constrained coding.
Funding Support: The Ford Foundation (Complete only if the funding support is provided from other than this award).

Name	Project Role	Researcher Identifier (e.g. ORCID ID):	Nearest person month worked	Contribution to project
Warren Grayson	Principal Investigator	0000-0001-6099-6469	3	Performed work towards bioreactor design. Worked on perfusion system process design.
Gerald Brandacher	Co-Investigator		0.5	Worked on animal model development
Gymama Slaughter	Co-Investigator		2	Worked on biosensor design
Sara Salehi	Graduate Student		12	Build perfusion system, establish abdominal wall perfusion and viability assessment
Shankara Narayanan Jeyaraman	Post-doc		12	Biosensor design and characterization
Kenny Tran	Graduate Student		12	Design Bioreactor and electrical stimulation system
Vanessa Guarnizo	Graduate Student		12	Abdominal wall surgery
Georg Furtmuller	Plastic Surgery Resident		0.5	Abdominal wall surgery and histological assessment
Samuel Fidder	Plastic Surgery Resident		0.5	Abdominal wall transplantation

Has there been a change in the active other support of the PD/PI(s) or senior/key personnel since the last reporting period?

New active grants:	
Brandacher, Gerald	
Title:	Deceased Donor Bone Marrow Salvage and Processing
Effort:	0.60 Calendar Months (5%) Role: Site PI (Woods)
Supporting Agency:	Ossium Health/NIAID
Performance Period:	01/01/2018-12/31/2018
Funding Amount:	\$42,089
Goals/Aims:	To develop an efficient and automated way to cryopreserve and bank bone marrow stem cells from cadaveric organ and tissue donors.
Overlap:	No scientific or budgetary overlap exists between the listed funding and the grant proposal under examination
Title:	Optimal Rewarming Solutions for Cryopreserved Tissue Systems
Effort:	0.60 Calendar Months (5%)Role: Site PI (Woods)
Supporting Agency:	Tissue Testing Technologies LLC (Sub); Defense Health Program (Prime)
Performance Period:	04/1/2018 -02/14/2019
Funding Amount:	\$149,579
Goals/Aims:	Task#3: In vivo assessment of graft viability and functional outcome by transplantation in a syngeneic rat orthotopic hind limb transplant model. Task#4 Investigation of the impact of cryopreservation and rewarming on a small human VCA tissue. (Task #1 and Task #2 performed in Year 1 at the labs of T3LLC and University of Minnesota.)
Overlap:	No scientific or budgetary overlap exists between the listed funding and the grant proposal under examination
Title:	Phase II: Non-Toxic, Highly Effective Bioinspired Cryoprotectants
Effort:	0.60 Calendar Months (5%) Role: Site PI : (Weis)
Supporting Agency:	X-Therma,Inc./DHP SBIR (Prime)
Performance Period:	08/01/2018-1/31/2019
Funding Amount:	\$149,968
Goals/Aims:	To develop a vascularized composite tissue storage method that extend the duration of extremity allograft
Overlap:	No scientific or budgetary overlap exists between the listed funding and the grant proposal under examination
Title:	Novel Cell Therapy-based Strategies to Induce Immune Tolerance in VCA
Effort:	0.60 Calendar Months (5%) Role: PI
Supporting Agency:	Kaohsiung Medical University Hospital
Performance Period:	07/01/2018-6/30/2019
Funding Amount:	\$45,615
Goals/Aims:	To establish and international research laboratory for translational and clinical cell therapy platforms at KMUH
Overlap:	No scientific or budgetary overlap exists between the listed funding and the grant proposal under examination
Title:	RT170093P3- Understanding and Supporting Public Information Needs about VCA Donation
Effort:	1.20 Calendar Months (10%) Role: Partnering PI (Segev)
Supporting Agency:	Congressionally Directed Medical Research Programs (CDMRP) Reconstructive Transplant Research
Grants Officer:	Karen L. Petrore (Karen.L.Petrore.civ@mail.mil)
Performance Period:	9/30/2018-9/29/2021
Funding Amount:	\$281,444
Goals/Aims:	To assess the availability and quality of information about VCA donation delivered through state and federally sponsored online registries, DoD/VA entities, and public awareness materials.

Overlap:	No scientific or budgetary overlap exists between the listed funding and the grant proposal under examination
Title:	RT150064: Long Term Banking of Vascularized Composite Grafts Using Ice-Free Cryopreservation by Vitrification and Nanowarming Technologies
Effort:	0.12 Calendar Months (1%) Role: Co-PI (Brockbank)
Supporting Agency:	Tissue Testing Technologies LLC (Sub); USAMRAA (Prime)
Performance Period:	01/01/2018 –8/31/2019 (NCE)
Funding Amount:	\$99,996
Goals/Aims:	Specific Aim 1: To establish baseline functions of warming protocols upon tissue of rat limbs. Specific Aim 2: In vivo assessment of graft viability and functional outcome by transplantation in a syngeneic rat orthotopic hind limb transplant model; Specific Aim 3: Investigation of the impact of cryopreservation and rewarming on alloimmunity and graft rejections/survival.
Overlap:	No scientific or budgetary overlap exists between the listed funding and the grant proposal under examination
Title:	RT170075: A Biocompatible Therapeutic Platform for Precise Regulation of Vascularized Composite Allotransplant Rejection via Enhanced Costimulation Blockage
Effort:	0.24 Calendar Months (2%) Role: Co-I (Raimondi)
Supporting Agency:	United States Army Medical Research Acquisition Activity (USMRAA)
Grants Officer:	Amber Stillrich (amber.d.stillrich.civ@mail.mil)
Performance Period:	9/30/2018-9/29/2021
Funding Amount:	\$750,234
Goals/Aims:	The goal of the project is to optimize the development and implementation of a biocompatible drug delivery technology for the localized delivery of Tofacitinib tailored to the intensity of graft rejection in a mouse VCA model and in a pilot swine transplant model.
Overlap:	No scientific or budgetary overlap exists between the listed funding and the grant proposal under examination
Title:	Phase II: Novel Super-Cooling of Genitourinary Cells and Tissues for Transplant
Effort:	0.60 Calendar Months (5%) Role: Site PI (Weis)
Supporting Agency:	X-Therma,Inc. (Sponsor)/ DoD SBIR (Prime)
Grants Officer:	Katrina White (katrina.l.white17.civ@mail.mil)
Performance Period:	10/01/2018-09/30/2019
Funding Amount:	\$199,035.00
Goals/Aims:	To develop a vascularized composite tissue storage method that extend the duration of extremity allograft
Overlap:	No scientific or budgetary overlap exists between the listed funding and the grant proposal under examination.
Title:	RT170034P1-Taming Endothelial Activation and Sterile Inflammation to Rescue VCA's from Preservation Injury
Effort:	1.20 Calendar Months (10%) Role: PI-Partnering(Weglinski)
Supporting Agency:	Congressionally Directed Medical Research Programs (CDMRP) Reconstructive Transplant Research Program
Grants Officer:	Amber Stillrich (amber.d.stillrich.civ@mail.mil)
Performance Period:	09/30/2018-09/29/2021
Funding Amount:	\$750,000
Goals/Aims:	To conduct the <i>in vivo</i> transplant studies for your project using our microsurgical animal models of orthotopic hindlimb transplantation in the mouse as well as our preclinical large animal model of heterotopic hindlimb transplantation in swine.
Overlap:	No scientific or budgetary overlap exists between the listed funding and the grant proposal under examination

What other organizations were involved as partners?

If there is nothing significant to report during this reporting period, state “Nothing to Report.”

Nothing to Report.

7. SPECIAL REPORTING REQUIREMENTS

COLLABORATIVE AWARDS: For collaborative awards, independent reports are required from BOTH the Initiating PI and the Collaborating/Partnering PI. A duplicative report is acceptable; however, tasks shall be clearly marked with the responsible PI and research site. A report shall be submitted to <https://ers.amedd.army.mil> for each unique award.

Nothing to Report.

QUAD CHARTS: If applicable, the Quad Chart (available on <https://www.usamraa.army.mil>) should be updated and submitted with attachments.

- 8. APPENDICES:** Attach all appendices that contain information that supplements, clarifies or supports the text. Examples include original copies of journal articles, reprints of manuscripts and abstracts, a curriculum vitae, patent applications, study questionnaires, and surveys, etc.

Nothing to Report.

Multi-parametric bioreactor for functional preservation of VCA



Log No: RT1600027P2

Award No: W81XWH-17-1-0287

PI: Grayson Org: Johns Hopkins University

Award Amount: \$487,094

Study/Product Aim(s)

- Design and build the bioreactor chamber for vascular perfusion and electrical stimulation of rat abdominal wall VCA
- Design, build, and test biosensors used for viability biomarker profile
- Optimize rat abdominal wall harvest and transplantation surgery
- Optimize the perfusate to improve graft viability by addition of colloid

Approach

- Perfuse abdominal wall for 12 hours with preservation solution to obtain data on tissue perfusion
- Design and test biosensors for ROS (using H2O2). Test linearity and reproducibility of the sensors
- Conduct syngeneic abdominal wall transplants and assess extended graft survival

Subtask 1.1

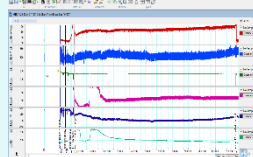

Perfusion System

Subtask 1.2

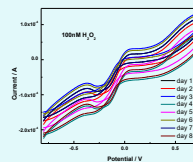
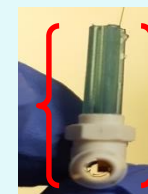

Subtask 2.2

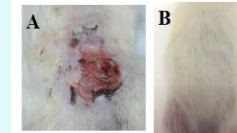
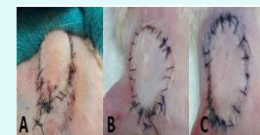

Long-term Survival of Abdominal Walls Transplantation

We have updated the design for the housing chamber for abdominal wall VCA. We also obtained and calibrated components of the perfusion loop. We changed the design of the ROS sensors and tested the range and stability. The IACUC and ACURO protocols were approved. We began testing the transplantation surgeries

Timeline and Cost

Activities		CY17	18	19	20
Task1	Investigate bioreactor and electrical stimulation system design	[Gantt bar]			
	Biosensors' design and system demonstration		[Gantt bar]		
	IACUC and ACURO approval		[Gantt bar]		
	Optimize rat abdominal harvest, transplant surgery		[Gantt bar]		
Task2	Preserve abdominal wall up to 72 hours		[Gantt bar]		
Task3	Adjust abdominal wall preservation system for forelimb preservation			[Gantt bar]	
Estimated Budget (\$K)		\$155K	\$165K	\$167K	

Updated: (October29, 2018)

Goals/Milestones

CY17-18 Goal – Design stand alone perfusion/electrical stimulation system to maintain viability of rat abdominal wall VCA.

Designed perfusion bioreactor and electrical stimulation and perfusion systems

Obtained and testing individual components

CY17-18 Goal – Develop in-line sensors to measure NO and ROS for real-time graft monitoring.

Developed prototype sensor for ROS.

Test sensitivity and linearity within perfusate

CY18 Goal – Investigate bioreactor system through preserving abdominal wall up to 72 hour

Obtain IACUC and ACURO approval

Optimize rat abdominal wall harvest and transplantation surgery

Comments/Challenges/Issues/Concerns

- None.

Budget Expenditure to Date

Projected Expenditure:

Actual Expenditure \$207,465