



ARL-CR-0838 • FEB 2019



# The Fast-neutron Laboratory for Active Interrogation Research (FLAIR) Radiation Safety Interlock System

prepared by JC Marsh

*Oak Ridge Associated Universities Fellowship Program  
Adelphi, MD*

under contract W911NF-12-2-0019

Approved for public release; distribution is unlimited.

## **NOTICES**

### **Disclaimers**

The findings in this report are not to be construed as an official Department of the Army position unless so designated by other authorized documents.

Citation of manufacturer's or trade names does not constitute an official endorsement or approval of the use thereof.

Destroy this report when it is no longer needed. Do not return it to the originator.



# The Fast-neutron Laboratory for Active Interrogation Research (FLAIR) Radiation Safety Interlock System

prepared by JC Marsh

*Oak Ridge Associated Universities Fellowship Program*

*Adelphi, MD*

under contract W911NF-12-2-0019

**REPORT DOCUMENTATION PAGE**

*Form Approved*  
OMB No. 0704-0188

Public reporting burden for this collection of information is estimated to average 1 hour per response, including the time for reviewing instructions, searching existing data sources, gathering and maintaining the data needed, and completing and reviewing the collection information. Send comments regarding this burden estimate or any other aspect of this collection of information, including suggestions for reducing the burden, to Department of Defense, Washington Headquarters Services, Directorate for Information Operations and Reports (0704-0188), 1215 Jefferson Davis Highway, Suite 1204, Arlington, VA 22202-4302. Respondents should be aware that notwithstanding any other provision of law, no person shall be subject to any penalty for failing to comply with a collection of information if it does not display a currently valid OMB control number.

**PLEASE DO NOT RETURN YOUR FORM TO THE ABOVE ADDRESS.**

<b>1. REPORT DATE (DD-MM-YYYY)</b> February 2019		<b>2. REPORT TYPE</b> Contractor Report		<b>3. DATES COVERED (From - To)</b> June 2014–Present	
<b>4. TITLE AND SUBTITLE</b> The Fast-neutron Laboratory for Active Interrogation Research (FLAIR) Radiation Safety Interlock System				<b>5a. CONTRACT NUMBER</b> W911NF-12-2-0019	
				<b>5b. GRANT NUMBER</b>	
				<b>5c. PROGRAM ELEMENT NUMBER</b>	
<b>6. AUTHOR(S)</b> JC Marsh				<b>5d. PROJECT NUMBER</b>	
				<b>5e. TASK NUMBER</b>	
				<b>5f. WORK UNIT NUMBER</b>	
<b>7. PERFORMING ORGANIZATION NAME(S) AND ADDRESS(ES)</b> Oak Ridge Associated Universities 100 ORAU Way Oak Ridge, Tennessee				<b>8. PERFORMING ORGANIZATION REPORT NUMBER</b>	
<b>9. SPONSORING/MONITORING AGENCY NAME(S) AND ADDRESS(ES)</b> Army Research Laboratory ATTN: RDRL-SED-E 2800 Powder Mill Road Adelphi, MD 20783-1138				<b>10. SPONSOR/MONITOR'S ACRONYM(S)</b>	
				<b>11. SPONSOR/MONITOR'S REPORT NUMBER(S)</b> ARL-CR-0838	
<b>12. DISTRIBUTION/AVAILABILITY STATEMENT</b> Approved for public release; distribution is unlimited.					
<b>13. SUPPLEMENTARY NOTES</b>					
<b>14. ABSTRACT</b> To help prevent accidental exposure to neutron radiation, it became necessary to design and build in a new location an interlock system in which to conduct neutron radiation operations. This document describes in detail the interlock for the new Fast-neutron Laboratory for Active Interrogation Research Neutron Exposure Chamber, the method of operation, and the operator control interfaces and warnings.					
<b>15. SUBJECT TERMS</b> radiation safety, FLAIR, Fast-neutron Laboratory for Active Interrogation Research, Neutron Exposure Chamber, interlock					
<b>16. SECURITY CLASSIFICATION OF:</b>			<b>17. LIMITATION OF ABSTRACT</b> UU	<b>18. NUMBER OF PAGES</b> 32	<b>19a. NAME OF RESPONSIBLE PERSON</b> JC Marsh
<b>a. REPORT</b> Unclassified	<b>b. ABSTRACT</b> Unclassified	<b>c. THIS PAGE</b> Unclassified			<b>19b. TELEPHONE NUMBER (Include area code)</b> 301-394-1761

## **Contents**

---

<b>List of Figures</b>	<b>iv</b>
<b>List of Tables</b>	<b>iv</b>
<b>1. Introduction</b>	<b>1</b>
<b>2. General Description</b>	<b>2</b>
<b>3. Theory of Operation</b>	<b>4</b>
<b>4. Conclusion</b>	<b>7</b>
<b>5. References</b>	<b>8</b>
<b>Appendix A. Standard Operating Procedure</b>	<b>9</b>
<b>Appendix B. Daily Safety Checklist</b>	<b>19</b>
<b>Appendix C. Electrostatic Neutron Generator Operating Procedure</b>	<b>21</b>
<b>List of Symbols, Abbreviations, and Acronyms</b>	<b>25</b>
<b>Distribution List</b>	<b>26</b>

## List of Figures

---

Fig. 1	Map of FLAIR (Neutron Exposure Chamber, Maze, and Control Room).....	1
Fig. 2	API-120 ENG.....	2
Fig. 3	API-120 internal interlock circuit.....	3
Fig. 4	Interlock operator interfaces .....	4
Fig. 5	Schematic of the FLAIR interlock. AC circuits are in blue. DC circuits are in black. The interlock relay series is in magenta. Major divisions are blocked out in orange.....	6
Fig. C-1	Main control box .....	22
Fig. C-2	Operator control box status LEDs.....	22
Fig. C-3	Neutron production indicators.....	24

## List of Tables

---

Table 1	List of components .....	7
---------	--------------------------	---

## 1. Introduction

After the end of the Cold War, many of the heavy radiation facilities at the Army Research Laboratory (ARL) (then Harry Diamond Laboratories) were decommissioned. This left two empty facilities designed for handling very high levels of radiation. One of the facilities, the Building 500 test cell, was eventually tasked into a general-purpose radiation testing chamber, with its interlock described in Ayegbusi et al.<sup>1</sup> The second facility is the former  $^{60}\text{Co}$  lab located in Building 504. This chamber was designed to house a 40-kCi  $^{60}\text{Co}$  source used to test equipment in a high-intensity  $\gamma$ -ray field. When ARL agreed to accept a National Electrostatics Corporation 9SDH ion accelerator from the Naval Surface Warfare Center, Carderock Division, it became necessary to move ARL's electrostatic neutron generator (ENG) out of the Building 500 test cell and into the old  $^{60}\text{Co}$  lab, hereafter referred to as the Fast-neutron Laboratory for Active Interrogation Research (FLAIR) facility. FLAIR contains a control room, radiation maze, and Neutron Exposure Chamber (NEC) housing the ENG (Fig. 1). The original interlock for this facility had been dismantled, so it was necessary to design and implement a new one.

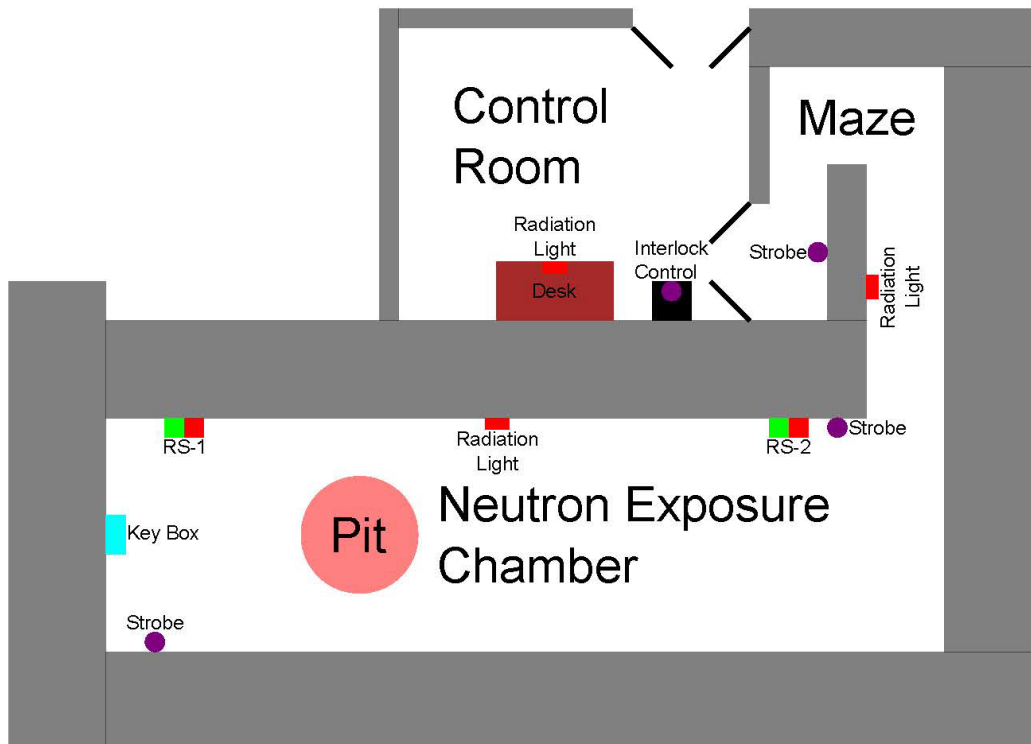

Fig. 1 Map of FLAIR (Neutron Exposure Chamber, Maze, and Control Room)

The neutron radiation is produced by a Thermo Scientific API-120 (Fig. 2) ENG acquired for a Joint Improvised-threat Defeat Organization project. The details and current status of this project are described in Marsh et al.<sup>2</sup> The API-120 is capable of producing a nearly isotropic field of 14.1-MeV fast neutrons at a rate of  $8.6 \times 10^6$  neutrons per second. This warrants the designation of any space within which the ENG is operating as a high radiation area requiring interlock controls to meet ARL and Nuclear Regulatory Commission (NRC) requirements. The standard operating procedure and daily safety checklist for the interlock are given in Appendixes A and B, respectively. The ENG operating procedure is given in Appendix C.



**Fig. 2** API-120 ENG

## **2. General Description**

---

The purpose of any safety interlock system is to implement engineering controls and facilitate administrative controls to ensure that personnel are not accidentally exposed to danger. In this case, the specific intent is to prevent exposure of personnel to the neutron radiation produced by the API-120. The API-120 has an internal 24-V interlock circuit (Fig. 3) that will prevent the device from operating unless all of the switches are closed, satisfying the circuit.<sup>3</sup> This circuit is connected to the exposure chamber interlock by pins A and B of the interlock connector on the API-120 chassis. When the NEC interlock is satisfied, it will close the connection between pins A and B to complete the API-120's internal interlock circuit.

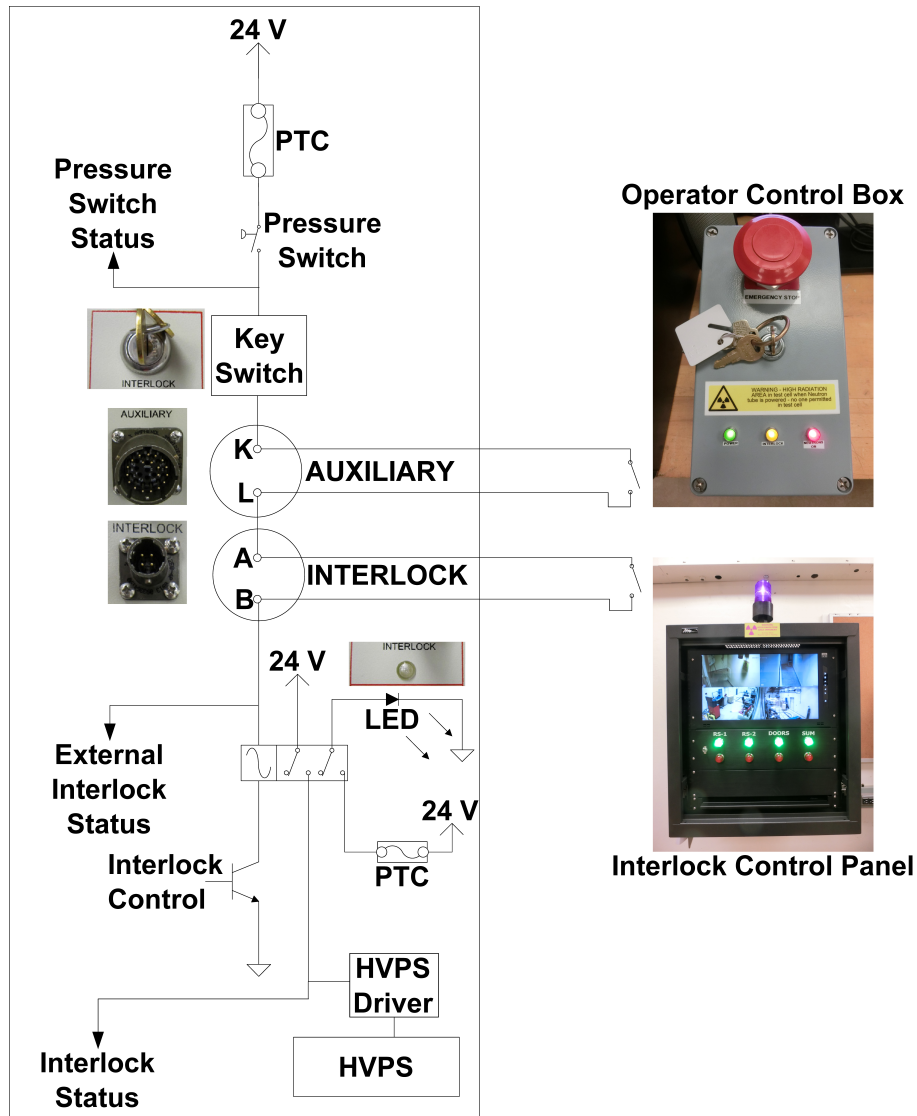

Fig. 3 API-120 internal interlock circuit

The NEC interlock is activated by turning on the 24-V power switch located on the interlock control panel (Fig. 4a), which is mounted outside the NEC in the control room (Fig. 1). This power is separate from the 24-V system internal to the API-120. The LEDs mounted in the interlock control panel that correspond to the statuses of the doors and run-safe boxes will light. To activate the interlock, the operator will enter the NEC (Fig. 1), set the run-safe boxes to green (Fig. 4b), then proceed to the key box located on the far wall (Fig. 4c). Inserting and turning the key will activate the area warning system consisting of magenta strobes (Fig. 4d) and an audible alarm. The cyan LED on the key box will illuminate, indicating that the timer has been activated. At this point, the operator will have 30 s to remove the key and exit the NEC, checking to ensure nobody is inside, and close the maze doors to the NEC. If the operator fails to close the maze doors within 30 s, it will

be necessary to reenter, press the reset button on the key box, and then insert and turn the key again. Once the NEC and maze have been cleared and secured, the interlock control panel LEDs will indicate all green, and the magenta strobe located on top of the interlock control panel will latch and remain active while the area is secured. The interlock is satisfied at this point, and neutron production is possible in the NEC.



(a) Interlock Control Panel



(b) Run Safe Box



(c) Key Box

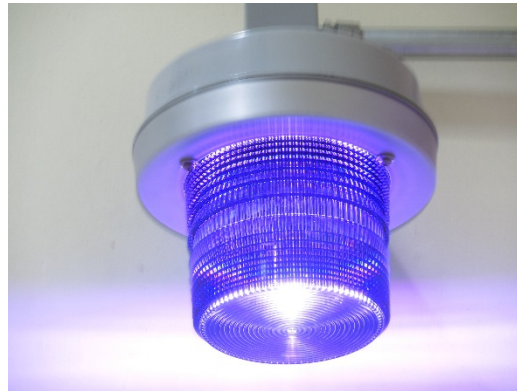

(d) Area Warning Strobe

**Fig. 4 Interlock operator interfaces**

### 3. Theory of Operation

---

The electrical theory behind this interlock system is a series of switches that must all be closed for the interlock to be satisfied. Indeed, a simple set of switches on the maze doors would, in principle, prevent radiation production with the doors open, but in order to meet ARL and NRC regulations, and maintain best practice, it is necessary to force the operator to sweep and certify that the room is empty each

Approved for public release; distribution is unlimited.

time the doors are opened. Toward that end, the system had to be expanded to meet these requirements.

To ensure a proper sweep, a key box that requires the operator to physically insert and turn a key is located on the far wall away from the maze. Once the key is turned and removed, the operator must sweep the NEC and maze and close the doors before time is up. A 30-s time limit was chosen to give the operator sufficient time to perform the sweep while preventing anyone from entering the room without the operator noticing.

Figure 5 shows the circuit diagram for the interlock system with the list of parts given in Table 1. To ensure that no connection exists in the event of a relay malfunction or power failure, mechanical relays were chosen instead of solid state relays. This ensures an air gap between contacts on the normally open sides of the relays. In the event of relay or power failure, the switches will reset to their normally open state, breaking the interlock circuit and shutting down neutron production.

The main power is controlled by toggle switch SW2. This provides power to the LEDs, relays, and the Sonalert audible alarm. The SW4 switch represents the key switch located on the far wall of the NEC. When SW4 is keyed, it activates relay K1. SW4 is a momentary contact switch, so power is tapped from between SW3 and SW4 and used to hold K1 closed until the reset button is pressed. Power for SW1, the time delay switch, is routed across K1. The K1 relay also controls power to the timer motor for switch SW1. The SW1 switch stays closed until the timer period expires, providing power for the K2 relay. Power for the Sonalert and area warning strobes is also controlled by K2, but most importantly, K2 functions as a bypass shunt for the door switches, temporarily satisfying the interlock while the operator sweeps the room.\* Along with setting the run-safe boxes to “RUN”, closing the doors completes the interlock circuit (pink trace).

To enforce the requirement for a room sweep, SW1 also powers relay K5. K5 powers K6, which closes only so long as the interlock circuit is satisfied before the timer expires. If the doors are opened, K6 releases, requiring the operator to reset the system (SW3) and reinsert the key. The final relay, K7, only closes when all of the above conditions are met. Along with powering the control room warning strobe, K7 is the connection point for the internal 24-V interlock in the API-120. As shown in Fig. 5, the API-120 internal interlock bridges K7.

---

\* At this point the ENG could be fired. This potential hazard is mitigated by placing the firing key on the same keyring, soldered closed, as the interlock key and placing it in the hands of the operator sweeping the room.

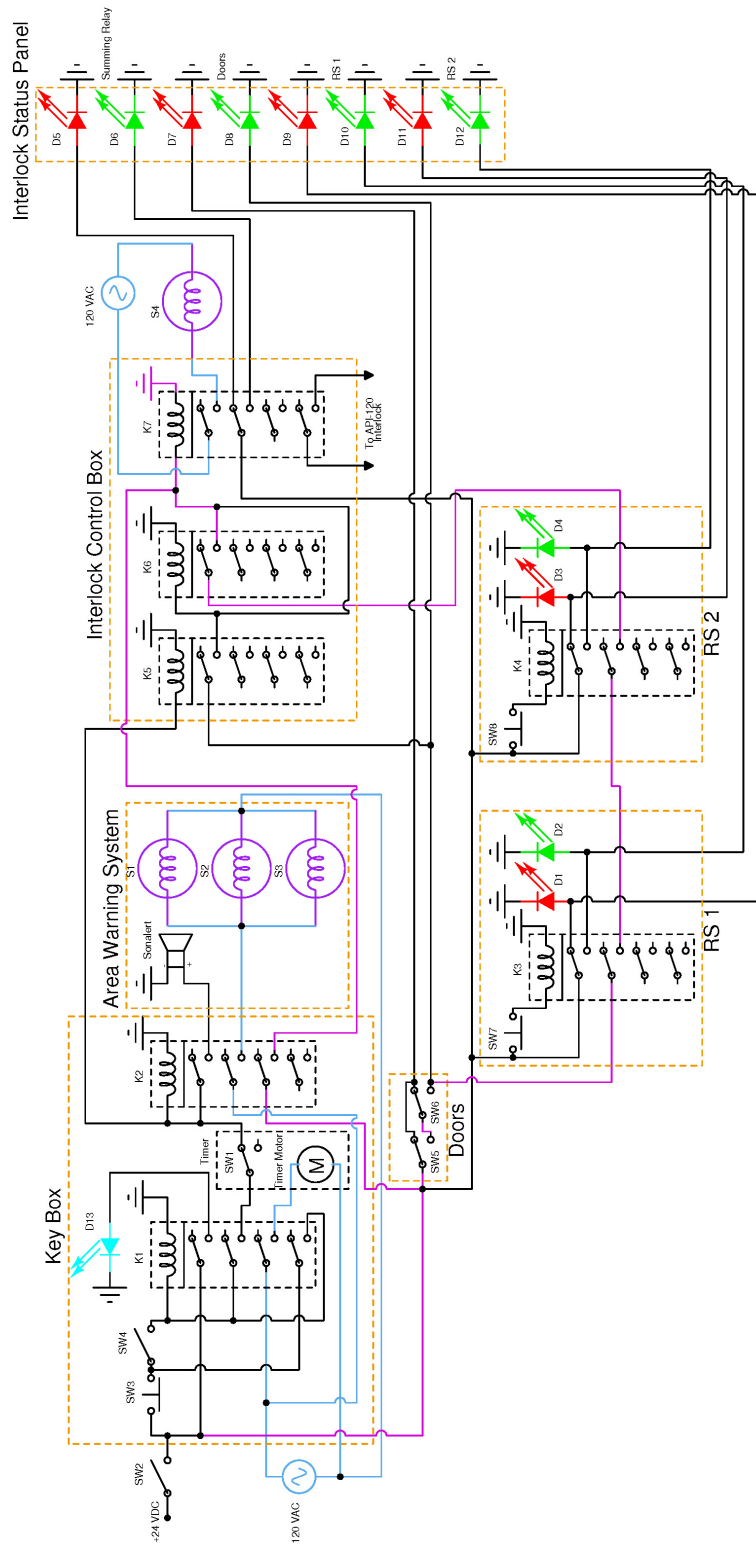

**Fig. 5 Schematic of the FLAIR interlock. AC circuits are in blue. DC circuits are in black. The interlock relay series is in magenta. Major divisions are blocked out in orange.**

**Table 1 List of components**

<b>Component</b>	<b>Type</b>	<b>Manufacturer</b>	<b>Part number</b>
K1–K7	QPDT relay	Magnecraft	784XDXC-24D
D1–D11 (Odd)	Red LED	Dialight	556-3504-304F
D2–D12 (Even)	Green LED	Dialight	556-3604-304F
D13	Cyan LED	Dialight	556-3684-304F
S1–S3	Magenta strobe	Edwards Signal	93M-N5
S4	Magenta strobe	Tomar	490S-120
SW1	Delay timer	Industrial Timer	CSF-1M
SW2	Power switch	Leviton	...
SW3	Push button, break	Grayhill	2202
SW4	Captive key switch	...	...
SW5–SW6	Door limit switch	Cutler-Hammer	CH10346H3072G
SW7–SW8	ESTOP push button	CAT	800T-FX-D4

#### **4. Conclusion**

---

An interlock system based on the functionality of the one in Building 500 was designed for the old  $^{60}\text{Co}$  lab in Building 504. The system was designed in such a way that the operator is required to enter the Neutron Exposure Chamber and insert and turn a key on the far wall each time they wish to produce neutrons. This forces the operator to perform an appropriate safety sweep to ensure no personnel are in the chamber when hazardous radiation levels are present.

## 5. References

---

1. Ayegbusi A, Almony B, Litz MS. 500 rad test cell radiation safety interlock system. Adelphi (MD): Army Research Laboratory (US); 2005. Report No.: ARL-TR-3687.
2. Marsh JC, Litz MS, Carroll JJ, Chiara CJ, Guardala NA, Demaree JD. Progress towards a LaBr<sub>3</sub>-based associated particle imaging test bed for contraband detection and bulk materials analysis. In: Fountain, AW, editor. Proc. SPIE 9824, Chemical, Biological, Radiological, Nuclear, and Explosives (CBRNE) Sensing XVII; 2016 Apr 17; Baltimore, MD. Bellingham (WA): Society of Photo-Optical Instrumentation Engineers (SPIE); c2016. <http://dx.doi.org/10.1117/12.2224157>.
3. API120 DNCII Dual Chassis Interlock – Customer (technical drawing). Colorado Springs (CO): Thermo Scientific; nd.

## **Appendix A. Standard Operating Procedure**

---

---

---

This appendix appears in its original form, without editorial change.  
Approved for public release; distribution is unlimited.

# STANDING OPERATING PROCEDURE\*

TITLE: Building 504 Neutron Generator Operations

DIVISION/BRANCH: Sensors and Electron Devices Directorate, Energy and Power Division, Power Components Branch, RDRL-SED-E

LOCATION: Building 504, Rooms 101 and 102

No deviations from this Standing Operating Procedure (SOP) will be permitted. Whenever the approved methods in this SOP must be changed, the SOP must first be revised and approved in writing by the Safety Office and Radiation Safety Committee. Supervisory personnel will assure that all personnel involved with this SOP have been trained properly and instructed in its provisions, and attest to this by causing them to affix their signatures on page 2 of this SOP. A copy of this SOP will be posted at the neutron operating console at all times.

---

---

Branch Chief: \_\_\_\_\_ Date: \_\_\_\_\_  
Division Chief: \_\_\_\_\_ Date: \_\_\_\_\_

---

APPROVED:

\_\_\_\_\_  
Radiation Safety Officer Date

\_\_\_\_\_  
Radiation Safety Committee Date

\_\_\_\_\_  
ARL Safety Chief Date

\_\_\_\_\_  
Electrical Safety Officer Date

\_\_\_\_\_  
Industrial Hygienist Date

\*This copy of the SOP is provided for reference only. Contact the RSO for the most up-to-date version.

**Appointment of Operators**

The following individuals have successfully completed Radiation Worker training from the Safety Office. They have been trained on the design and proper operation of all radiation safety shielding, interlocks, warning, and control systems. They have also been reviewed and approved by the Radiation Safety Committee to serve as an Operator for neutron operations in Building 504.

_____	_____	_____
Approved ENG Operator	Branch Chief	Date
_____	_____	_____
Approved ENG Operator	Branch Chief	Date
_____	_____	_____
Approved ENG Operator	Branch Chief	Date
_____	_____	_____
Approved ENG Operator	Branch Chief	Date
_____	_____	_____
Approved ENG Operator	Branch Chief	Date

**Operator Signatures**

The following signature acknowledges that I have read and understand the SOP entitled Building 504 Neutron Generator Operations. My signature further acknowledges that I understand that Building 504 neutron operations involve radiation hazards, have instructed any visitors present in the facility during ENG operations as to the radiation hazards and precautions described in the SOP, will provide constant direction and oversight over any visitors present during operations, and that I will follow the precautions and procedures specified in this SOP:

Name	Date
_____	_____
_____	_____
_____	_____
_____	_____
_____	_____



1. **STATEMENT OF WORK:** This SOP will regulate the operation of the Electrostatic Neutron Generators (ENG) in Building 504. Room 102 will serve as the control room, and Room 101 will serve as the neutron tube operating room and associated maze entrance. The ENGs can create a High Radiation Area (HRA), so Room 101 must be vacated before neutrons are generated.
2. **HAZARDS INVOLVED:**
  - (a) **Neutron Generating Tubes:** When the ENG is operating at  $2 \times 10^7$  n/sec, it can create an ionizing dose rate of about 356 mrem/hr at one foot. This classifies as a High Radiation Area. This level could result in an overexposure.
  - (b) **Activation Products:** The neutrons produced by the ENG can activate surrounding materials and structures to become radioactive. This is not a dangerous source of radiation, but waiting periods following irradiations will be used to minimize exposure to the resulting beta and gamma radiation.
  - (c) **Electrical Hazard:** The ENGs are powered by electricity, and electrical hazards will exist inside the tubes and power supplies.
3. **PROTECTION STANDARDS/LIMITS:**
  - (a) **Neutron Radiation:**
    - i. **Radiation Worker:** The annual limit for exposure to a Radiation Worker is 5 rem/yr. The ENG will produce about 0.356 rem/hr at one foot. It would therefore require about 14 hours at one foot to exceed the annual limit for exposure.
    - ii. **Unrestricted Area Limits:** The limit for unrestricted areas is 0.002 rem/hr, not to exceed 0.100 rem/yr. Exposure below these levels is considered insignificant. For the ENG, 0.002 rem and 0.100 rem would be exceeded in 20 seconds and 17 minutes, respectively.
    - iii. **Neutron Activation Products:** The neutrons from the ENG will activate the tube and other structures and materials close by. At  $2 \times 10^7$  n/sec, neutron activation is not typically a problem. Following one hour of ENG run time, the expected activity is only about 1  $\mu$ Ci: for ten hours of run time, the upper limit on the expected activity is only about 10  $\mu$ Ci. These activity levels are not capable of creating a hazard. Nonetheless, in accordance with the ALARA principle, operators will wait before entering the test cell post-exposure to allow the neutron

activation products to decay. A portable survey meter will always be used upon re-entry to detect any radioactivity that may have been produced by the neutrons.

- (b) **Electrical Hazard:** This operation may involve the use of electrical circuits, components, power supplies, capacitors, etc., that can present high voltages or other electrical hazards. **All workers must successfully complete formal Electrical Worker training. Contact the ARL Safety Office for training. ARL personnel and contractors are not permitted to remove covers or panels, perform work within the Limited Approach Boundary, or work on or near exposed electrical hazards under this SOP, as it would expose them to electrical hazards. That work requires a separate SOP approved by the ARL Safety Office.** When working with electrical hazards is required, contracting the manufacturer or manufacturer's representative to do the work is required unless prior approval to do the work is issued by the Safety Office and Branch Chief.
- (c) **Combustibles and Chemicals:** Do not use any combustibles or chemicals until cleared by the ARL Safety Industrial Hygienist, 394-6304.

#### 4. SAFETY CONTROLS:

- (a) **Engineering Controls:**
  - i. **Neutron Shielding:** The shielding in Room 101 is designed to contain radiation. Monte Carlo shielding analysis for each shield wall, the roof, the Room 101 ventilation duct, the entrance maze and hallway, and S tubes traveling through the wall between Rooms 101 and 102 predicts that the shielding structure is protective. The radiation dose level outside of any of these locations is not expected to exceed 0.06 mrem/hr, which is well below the 2 mrem/hr criterion for an unrestricted area. Assuming 500 hours of operation per year, the annual dose is expected to be below 30 mrem/yr, which is well below the annual unrestricted area criterion of 100 mrem/yr. Verification surveys will be conducted to ensure the Monte Carlo predictions are accurate.
  - ii. **Interlock System:** The maze doors will be equipped with interlock switches wired in series on each door and connected to the radiation chamber interlock system to prevent ENG tube operation if a maze door is open. To set the interlock circuit and allow operation of the ENG, the operator must enter the radiation chamber, make certain that the run-safe boxes are in the "Run" position, proceed to the interlock system reset key box located on the far wall, and insert and turn the key

to signal to personnel that the operator intends to produce radiation. Turning the key will activate the area warning system inside the radiation chamber, maze, and control room consisting of four magenta strobes (two in the chamber, one in the maze, and one in the control room) and an audible alarm. A blue LED on the reset key box will illuminate indicating that the timer has been activated, and the operator will have 30 seconds to remove the key and exit the room, checking to ensure nobody is behind them, and close the maze doors. If the operator fails to close the doors within 30 seconds for any reason, the interlock system will not be satisfied, and the operator will have to re-enter the radiation chamber and repeat the entire sequence. If the chamber is cleared and the maze doors closed within 30 seconds, the status panel on the interlock control panel in the control room will indicate “all green,” and a fourth magenta strobe in the control room will activate and stay on until the chamber interlock has been broken. At this point, the interlock system is satisfied, and neutron production is possible. In order to reduce the chances of a single door switch failing, two switches in series will be used to monitor the maze doors. Since the ENGs do not create a VERY High Radiation area, using a blade switch to interrupt the tube energy source is not required as it is with the X-ray sources used in the Building 500 test cell.

- iii. **Keys:** The key to the ENG control unit will be on the same key ring, soldered closed, as the interlock reset key and the maze key. This will only allow one neutron tube to be used at a time, and will further prevent any attempt to produce neutrons while someone is in the test cell resetting the interlock system.
- iv. **Emergency Shutdown Stations:** Two push-type “Emergency Shutdown” stations are mounted inside the test cell. They will prevent or terminate neutron production when pushed. The ENG also has an Emergency Shutdown button mounted on its chassis by the manufacturer. A final Emergency Shutdown station is provided on the operator control box at the ENG control station.
- v. **Warning Lights:** Four flashing magenta warning lights are mounted (two in the chamber, one in the maze, and one in the control room) to provide a visual warning for personnel to clear the room during the 30 second sweep. An audible warning is also provided inside the radiation chamber. The magenta strobe located on top of the interlock control cabinet in the control room will activate during the sweep and stay

activated while the interlock is satisfied. Finally, three red strobes (one in the chamber, one in the maze, and one above the ENG control station) will activate while neutrons are being produced.

(b) **Administrative Controls:**

- i. **Authorized Operators:** Only individuals who have successfully completed radiation worker training through the ARL Safety Office, have been trained in the safe and proper operation of the ENG, and have been reviewed and approved in advance by the ARL Radiation Safety Committee, will be permitted to operate the ENG. Operators must also be individually appointed by the Branch Chief on page 2 of this SOP. Furthermore, operators are required to read this SOP and sign page 2 acknowledging understanding and vowing compliance.
- ii. **Access Control:** Only Radiation Safety Committee approved authorized Operators or Radioactive Material Workers can have the keys to enter Room 101 where the ENG tubes are stored and used. The ENG operating keys, interlock system reset keys, and maze keys will be kept on the same key ring and under the constant control of an Operator. When these keys are not being used, they will be kept in the possession of an Operator, or locked in a lock box under the control of the Operator. The ENG contains Nuclear Regulatory Commission (NRC) licensed radioactive material. The NRC requires the material be secured from unauthorized use or theft. This will be ensured by keeping the doors to Rooms 101 and 102 locked, with access to the keys limited to authorized Radioactive Material Worker or ENG operators.
- iii. **Postings:** This SOP and the NRC license and corresponding Radiation Work Permit for the ENG must be posted in Room 102 near the operating consoles at all times.
- iv. **Radiation Dosimeters:** During ENG operations, all operators and other personnel present that must enter Room 101 shall wear a radiation dosimeter issued by the Safety Office (Michael Borisky, 301-394-6310).
- v. **Repair and Maintenance:** In the event of a major malfunction, only a qualified ENG company repair/service technician may correct the malfunction. Following any repair or maintenance that involves the radiation shielding, shielding doors, or warning/interlock system, contact the Radiation Safety Officer for re-survey before ENG operations resume.

- vi. **System Check:** Each day, prior to the start of ENG operations, the operator will test and document that all safety devices are functioning properly. This includes the interlock system reset circuit, each door switch, the emergency stop buttons, the Sonalert, and the warning lights. A checklist has been formulated to help the operator conduct and document these daily checks, and is available from the Radiation Safety Officer (394-6310).
- vii. **Waiting for Decay of Activation Products:** Following ENG operations, it will generally be required to wait 10-15 minutes before entering Room 101 to allow any activation products created to decay away. This time can be adjusted once experience is gained to understand the activity generated, and the associated half-life. **FURTHERMORE, A PORTABLE RADIATION METER WILL BE USED WHENEVER AN OPERATOR RE-ENTERS ROOM 101 FOLLOWING NEUTRON BEAM USE. A LOG OF THE BEAM FLUX, TARGET MATERIAL, ON-TIME, WAITING TIME, AND MEASURED RADIATION LEVELS WILL BE MAINTAINED BY THE OPERATORS FOR EACH NEW TARGET MATERIAL AND RUNS OVER TWO HOURS.**
- viii. **Housekeeping:** The ENG shall not be used unless the housekeeping in Room 101 is good enough for the operators to easily and accurately detect the presence of personnel in Room 101. This will facilitate clearing personnel in preparation for an irradiation.
- ix. **Expected Activation Products:** Before any neutron irradiations of non-standard materials is conducted, a calculation of expected activated material production will be conducted so the relative hazard and waiting times can be anticipated.

## 5. SEQUENCE OF OPERATIONS:

- (a) Before the first ENG use of the day, complete the daily check list to verify all safety controls are functioning properly. If they are not, contact the Radiation Safety Officer for resolution before using the ENG tube.
- (b) Announce intent to prepare Room 101 for neutron production.
- (c) Take the key ring with the ENG operating and interlock reset keys, enter Room 101, and inspect to ensure the room is clear of personnel.
- (d) Once all personnel have left, activate the interlock system reset switch, immediately exit Room 101, and secure the maze entrance doors.

- (e) Begin the ENG irradiation.
  - (f) If for any reason a maze door is opened, the entire sequence above must be repeated.
  - (g) Following ENG use, wait fifteen minutes (or a waiting time determined from prior experience) before entering Room 101. **FOLLOWING ENG USE, A PORTABLE RADIATION METER WILL BE USED WHENEVER AN OPERATOR RE-ENTERS THE TEST CELL. A LOG OF THE BEAM FLUX, TARGET MATERIAL, ON-TIME, WAITING TIME, AND MEASURED RADIATION LEVELS WILL BE MAINTAINED BY THE OPERATORS FOR ANY NEW TARGET MATERIALS OR LONG IRRADIATION TIMES (> 2 hours).**
  - (h) Contact the Radiation Safety Officer in the event that UNEXPECTED residual radiation is detected so a further evaluation and characterization can be completed before proceeding.
6. **EMERGENCIES:** In the event of an emergency, immediately stop generation of neutrons and terminate power to the ENG. In the event of a safety system failure, or accidental or suspected personnel exposure, halt ENG operations immediately and do not restart operations until approved by the Radiation Safety Officer at 301-394-6310 or 410-278-6354.

---

**Report all accidents (injuries<sup>†</sup>, spills, fires, etc.) to your supervisor and the ARL/ALC Safety Team at (301) 394-2237. For all emergencies during non-business hours, call 911 and then the ARL Emergency Number at (301) 394-1117.**

---

<sup>†</sup>Work-related injuries and illnesses need to be reported by the employee and supervisor to the Occupational Health Clinic, but not spills and fires.

## **Appendix B. Daily Safety Checklist**

---

---

---

This appendix appears in its original form, without editorial change.  
Approved for public release; distribution is unlimited.

**ALC Building 504 Rooms 101 & 102 Neutron Exposure Chamber (NEC) Daily Safety Checklist**

These safety checks shall be accomplished at the start of **each day that the Thermo Scientific API-120 (or other RSC approved Electrostatic Neutron Generator) will be used.** If any test reveals any malfunction, contact the Radiation Safety Officer (RSO) immediately (Mike Borisky, 301-394-6310) and do not produce radiation. Neutrons shall not be produced unless all safety systems, including visible lights, audible alarms, interlock switches, security cameras, and emergency shutdown buttons are working properly. Operator observations must be recorded by circling below. If any non-bolded observations are recorded, do not proceed with radiation production since this indicates that not all radiation generation conditions are safe. Each completed checklist must be kept by the operator for an indefinite period for eventual transfer to the Radiation Safety Officer for archiving.

Date:

Time:

Operator:

1. Turn on the power to the interlock system and ENG.
2. Open the right maze door, enter the NEC, and press each panic button.
 

(a) Is the "Doors" indicator LED on the interlock panel red:	<b>YES</b> NO
(b) Is the "RS-1" indicator LED on the interlock panel red:	<b>YES</b> NO
(c) Is the "RS-2" indicator LED on the interlock panel red:	<b>YES</b> NO
(d) Is the "Interlock Circuit Summary" indicator LED on the interlock panel red:	<b>YES</b> NO
3. Close the right maze door.
 

(a) Is the "Doors" indicator LED on the interlock panel green:	<b>YES</b> NO
--	---------------
4. Open the left maze door while holding the right maze door closed.
 

(a) Is the "Doors" indicator LED on the interlock panel red:	<b>YES</b> NO
--	---------------
5. Clear the panic buttons, close the left maze door, but leave the right maze door open.
 

(a) Activate the interlock system reset key switch.	
i. Are the warning lights in the NEC (2), maze (1), and control room (1) flashing:	<b>YES</b> NO
ii. Is the Sonalert in the NEC beeping:	<b>YES</b> NO
iii. Time until the Sonalert stops beeping (Should be about 30 seconds):	_____
(b) Put the Radiation Warning Lights into TEST mode.	
i. Are both Radiation Warning Lights flashing:	<b>YES</b> NO
(c) Sweep and exit the NEC, then close the right maze door.	
i. Is the "Interlock Circuit Summary" indicator LED on the interlock panel red:	<b>YES</b> NO
ii. Is API-120 neutron production possible:	<b>YES</b> <b>NO</b>
(d) Enter the NEC, reset the interlock system, exit, and close the right maze door within 30 seconds.	
i. Is the "Doors" indicator LED on the interlock panel green:	<b>YES</b> NO
ii. Is the "RS-1" indicator LED on the interlock panel green:	<b>YES</b> NO
iii. Is the "RS-2" indicator LED on the interlock panel green:	<b>YES</b> NO
iv. Is the "Interlock Circuit Summary" indicator LED on the interlock panel green:	<b>YES</b> NO
6. Open the right maze door.
 

(a) Is the "Interlock Circuit Summary" indicator LED on the interlock panel red:	<b>YES</b> NO
--	---------------
7. Sweep and exit the NEC, then close the right maze door without resetting the interlock key switch.
 

(a) Is the "Interlock Circuit Summary" indicator LED on the interlock panel red:	<b>YES</b> NO
(b) Is API-120 neutron production possible:	<b>YES</b> <b>NO</b>
8. Is a calibrated  $\beta$ - $\gamma$  radiation detector present for reentry: **YES** NO
9. Are all four cameras functioning: **YES** NO
10. Have visitors been instructed per the SOP and signed in the visitor section of the SOP: **YES** NO
11. Is the operator approved by the Branch Chief, RSO, and Radiation Safety Committee: **YES** NO

Approved for public release; distribution is unlimited.

## **Appendix C. Electrostatic Neutron Generator Operating Procedure**

---

---

- 1) Power on the API-120 by twisting the red POWER button on the main control box (Fig. C-1) in the Neutron Exposure Chamber (NEC) clockwise until it pops up.



**Fig. C-1 Main control box**

- a) Power Indicators
  - i) Audible cooling fan
  - ii) Green POWER LED on the main control box in the NEC (Fig. C-1)
  - iii) Green POWER LED on the operator control box in the control room (Fig. C-2a)
- 2) Test the red area warning beacon by toggling the bypass switch on the relay box.



(a) Power On

(b) Interlock Set

(c) Neutrons On

**Fig. C-2 Operator control box status LEDs**

Approved for public release; distribution is unlimited.

- 3) Log into the control PC and start the DNCII software.
- 4) Perform the daily safety checklist.
- 5) Sweep and clear the NEC.
- 6) Insert the operator key in the operator control box and turn to complete the API-120 internal interlock.
- 7) On the control PC, click “Clear Faults” to reset the API-120 internal interlock (see Fig. C-3a). If any faults remain, open “Fault Analysis” under the “Screen” drop-down menu. The yellow INTERLOCK LED on the operator control box (Fig. C-2b) will light once all faults are cleared and the interlock is set.
- 8) Set Beam Control to 55  $\mu$ A and HV Control to 80 kV.
- 9) Begin neutron production by flipping the digital toggle switch on the control PC (Fig. C-3a). The red NEUTRONS ON LED (Fig. C-2c) will light, and the area warning lights will activate when neutron production begins.
  - a) Neutron Production Indicators
    - i) Red lights for “Interlock” and “Fault” indicators will turn green and the “Neutrons” indicator will flash red (Fig. C-3a)
    - ii) Flashing NEC area warning beacons (Fig. C-3b)
    - iii) Flashing operator station area warning beacon (Fig. C-3c)
    - iv) Red NEUTRONS ON LED on operator control box is lit (Fig. C-2c)

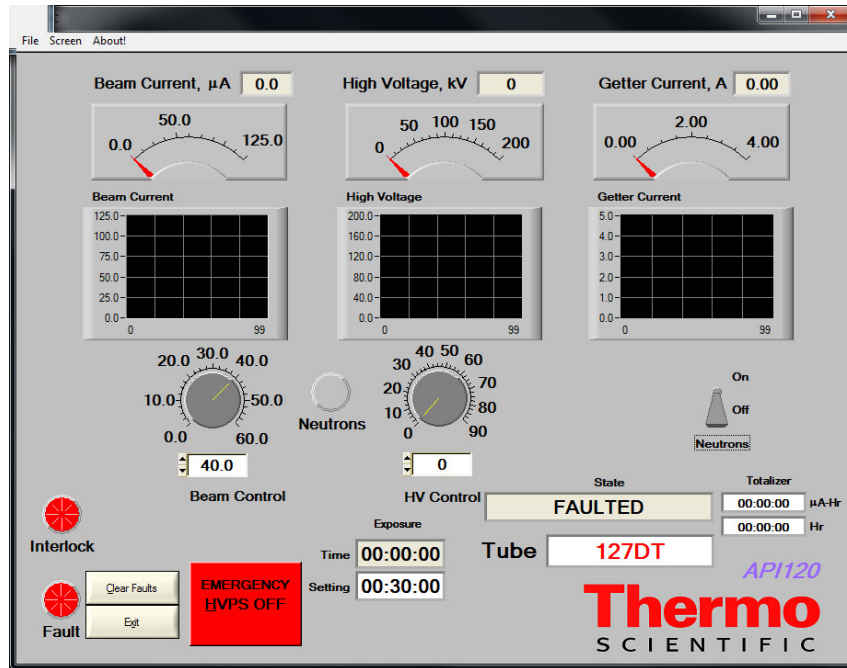

(a) Neutron Production Active (top)

(b) NEC Area Warning Strobe (bottom left)

(c) Operator Area Warning Strobe (bottom right)

**Fig. C-3 Neutron production indicators**

## List of Symbols, Abbreviations, and Acronyms

---

AC	alternating current
ARL	US Army Research Laboratory
DC	direct current
ENG	electrostatic neutron generator
FLAIR	Fast-neutron Laboratory for Active Interrogation Research
LED	light-emitting diode
NEC	Neutron Exposure Chamber
NRC	Nuclear Regulatory Commission
PC	personal computer

1 DEFENSE TECHNICAL  
(PDF) INFORMATION CTR  
DTIC OCA

2 DIR ARL  
(PDF) IMAL HRA  
RECORDS MGMT  
RDRL DCL  
TECH LIB

1 GOVT PRINTG OFC  
(PDF) A MALHOTRA

1 ARL  
(PDF) RDRL SED E  
J CARROLL