

NUC TN 504

Archive Copy

85261  
P1

**EFFECT OF POLYMER  
ADDITIVES ON NOZZLE  
STREAM COHERENCE:  
A PRELIMINARY STUDY**

by

**J. H. Green**

**HYDROMECHANICS DIVISION  
FLEET ENGINEERING DEPARTMENT**

**NAVAL UNDERSEA RESEARCH  
AND DEVELOPMENT CENTER**

San Diego, California 92132



**TECHNICAL**

**MAR 3 1971**

**LIBRARY**

**N.U.C.**

**APPROVED FOR PUBLIC RELEASE, DISTRIBUTION UNLIMITED**

**MAR 1971**



\*106048\*

## INTRODUCTION

It is well known that certain water-soluble polymers will substantially reduce pipe-wall friction in turbulent flow situations. Pipe-line pressure-drop reductions of up to 75% (depending on Reynolds' number) have been obtained with polymer concentrations of only a few parts per million, and these results have been readily duplicated by many independent investigators.

Civic fire departments have become interested in using the effect, and recently publicized has been a program by NYFD in collaboration with Union Carbide, producer of the highly effective friction-reducing polymer, poly(ethylene oxide), (tradename Pol-yox). Fire fighting applications could use the technique to reduce friction drop along hose lays so as to increase nozzle pressure for greater throw, increase flow through existing lays, reduce pumping power requirements, extend hose length without sacrificing flow rate, or reduce the hose diameter for a given application. Precisely how polymer friction reduction should be exploited would depend upon the specific fire fighting application; for instance, increased nozzle pressure for greater throw might be of prime interest in fighting high-rise fires, whereas extending hose length or reducing hose diameter might be of greater concern in fighting brush fires.

Another way in which dissolved polymers might aid fire-fighting applications would be in improving stream coherence so as to concentrate the water delivery pattern, make the stream dispersion less sensitive to wind, and possibly to further increase stream throw. This study was directed towards obtaining controlled observations of the stream coherence effect. It was to be a limited investigation involving readily available equipment where relatively few parameters could be studied, and these only over a restricted range of conditions as dictated by the test apparatus. A more thorough investigation would depend upon results of this preliminary study.

## BACKGROUND OF CURRENT STUDY

The Naval Undersea Research and Development Center (NUC) has been formulating polymer slurry systems and developing high-speed polymer mixing devices. A slurry formulation involves suspending the dry polymer powder in a liquid carrier (such as kerosene or alcohol) which will not dissolve the powder. The paste-like slurry can then be injected directly into a pipeline, where rapid dispersion and hydration of the polymer follows.

During evaluation of a slurry injector, polymer solution was being prepared along a length of  $1\frac{1}{2}$ " fire hose at the rate of 100 GPM. A particularly high polymer concentration of 1% (i.e., 10,000 ppm) was being prepared, as opposed to a concentration of only 200-300 ppm which is normally used for fire hose friction-reduction applications. A substantial improvement in the rod-like coherence of the free stream was noted at the nozzle discharge (Figure 1). Breakup of the plain-water stream into

spray and droplets occurred soon after leaving the nozzle tip. By comparison, the thickened polymer stream retained its coherence for a greater range, and the eventual breakup occurred in string-like ligaments rather than spray or droplets. Nozzle pressure was held constant for both tests, and no dramatic increase in throw was noted.

It was felt the coherent-jet effect should be studied further, with thought of a possible application in maintaining stream delivery under high-wind conditions on ship decks. As such, Mr. R. Proodian of the Naval Ship Engineering Center (NAVSEC 6101E) and Mr. E. Bukzin of the Naval Ship Systems Command (NAVSHIPS 03421) sponsored the later work reported here.

#### NOZZLE DESIGN CONSIDERATIONS

In designing effective nozzles and monitors, primary attention is directed toward reducing turbulence in the high-velocity water stream as it exits from the tip. Straightening vanes or honeycomb passages are often used upstream of the nozzle to break up large-scale eddies into smaller ones which rapidly decay in a flow length of several diameters before reaching the nozzle entrance. The exact shape of the contracting nozzle is not highly critical, providing the sidewall angles are not so steep as to cause flow separation with resulting turbulence. On the other hand, excessively long tapered nozzles can also produce turbulence because of the long flow lengths involved. Some nozzles are standardized with a  $7^\circ$  convergence ( $14^\circ$  included angle) although other investigators have found that very short nozzles with rounded entrances are equally effective.

Flow turbulence can be described as rotational eddies of different size that are carried along with the main flowstream. Because of their rotational nature, these eddies have velocity components that are perpendicular to the flowstream. Prior to reaching the nozzle tip, the lateral velocity components are confined by the walls of the hose or nozzle barrel. However, upon leaving the nozzle, the surface of the stream is no longer confined and the lateral velocity components of turbulence are free to cause surface eruptions. While the air drag on a smooth, rod-like jet would be relatively low, the effect of air drag on surface eruptions becomes appreciable. In addition, the lateral velocity components cause a continuing expansion of the jet, with an increasing cross-sectional area and further air drag. The surface eruptions are peeled off as droplets and spray, and the expanding central core eventually disintegrates under the increasing influence of air drag.

Over the years, continuing improvements in nozzle performance have resulted from modifications to progressively reduce turbulence. Since the mechanism whereby high polymers reduce friction is one of suppressing turbulence, this technique appeared to offer promise in maintaining jet coherence. While extremely dilute polymer solutions are effective in reducing pipe-line friction, the polymer presence can barely be detected by touch even at concentrations of 300 ppm. However, at concentrations of, say, 0.5%

(i.e., 5,000 ppm) the polymer solutions are very thick and mucus-like. These thickened solutions are capable of supporting certain flow stresses, and it was thought this feature might aid in maintaining jet coherence, as suggested by the single preliminary experiment shown in Figure 1.

#### TEST APPARATUS

Even a slight breeze has a substantial effect on jet-stream breakup, and it would have been impractical to await dead calm conditions in order to remove that variable for all testing. Also, it was felt that the greatest improvement by polymer additive might be seen under wind conditions when breakup was ordinarily promoted. Therefore, the initial approach was to observe two side-by-side jetstreams, one plain water and one polymer solution, exiting from identical nozzles at identical feed pressures. In this way, both streams would experience the same wind conditions, and various wind conditions could be observed and photographed as they occurred.

The test apparatus is shown in Figure 2. The premixed polymer solution was stored in the 550-gallon tank and pressurized air-on-fluid was used to feed one of the nozzles. The second nozzle was fed from a water main. Flows were adjusted so identical pressures existed at each nozzle entrance, as sensed by the gages shown in Figure 2. Both nozzles were inclined at  $20^\circ$  above the horizontal for all testing. Checkout testing with plain water thru both nozzles showed identical streams.

A cross-section view of the nozzle assembly is shown in Figure 3. The nozzles were assembled from readily-available parts, as it was desired to minimize the investment in apparatus for this initial study. Nozzle barrels were assembled from standard pipe fittings, and the removable tips machined from clear lucite. All testing was originally planned for the short, 0.25" nozzles. The long 0.525" nozzles were later machined and used during only one final test.

While the abrupt step at the base of the short nozzle would ordinarily be poor design practice, it was felt that the relatively low flow velocities in the  $1\frac{1}{2}$ " feed pipe would not produce excessive turbulence at the nozzle entrance. An attempt was made to reduce this step when designing the 0.525" tip, as seen in Figure 3, but a discontinuity still existed at the coupling. Again, these nozzles were assembled with a view towards minimizing cost, but it would be wise to custom machine smoothly joined assemblies for any future testing, if at all possible, in order to better model commercial nozzles.

#### SIDE-BY-SIDE COMPARISON TESTS (0.25" NOZZLES)

Initial testing was done with the side-by-side 0.25" tip nozzles. Four different polymer solution concentrations were tested at this time; 90, 290, 627, and 6800 ppm Polyox WSR-301 (Union Carbide). The best effect was observed with the 290 ppm solution,

as shown in Figure 4. Close to the nozzle, the polymer-solution jet retained a smooth, transparent, rod-like appearance, whereas the plain-water jet started to expand immediately and surface eruptions made the stream appear opaque. Spray and droplets began to peel from the plain-water jet only a few feet from the nozzle tip, and the central core appeared to have completely disintegrated by the time it reached maximum height. By comparison, disintegration of the polymer-solution jet appeared to be both delayed and reduced substantially, with eventual breakup appearing as ligaments rather than drops or spray, even at this reduced concentration of only 290 ppm. Results with the 637 ppm polymer solution appeared essentially identical to those obtained with 290 ppm, but the effect was noticeably reduced with the 90 ppm concentration.

The 0.25" nozzle tips were tested at base pressures of 50 and 100 psig, resulting in exit velocities of 86 and 121 fps, respectively. Figure 4 shows results obtained at the 50 psi nozzle-base pressure, and a comparable improvement between the two jets was also observed at the 100 psi pressure. Wind gusts of approximately 15 mph experienced during the test sequence made the comparison results even more impressive. The plain water spray was easily deflected by a slight breeze, whereas only the strongest gusts had a noticeable effect on the polymer solution stream.

While this initial testing with the 0.25" nozzle indicated that approximately 300 ppm was an optimum polymer concentration for improving jet coherence, it was decided to test a highly thickened concentration because of the preliminary result with the 1½" fire hose (Figure 1). A 6800 ppm concentration was tested with the results shown in Figure 5. The jet "swelled" immediately upon exiting from the nozzle tip, and the stream quickly broke up into ligaments within a few feet. Catch-and-weigh testing showed the nozzle discharge coefficient with the 6800 ppm solution to be half of that obtained with water. No change in discharge coefficient had been measured with the lower concentrations. This jet swelling and associated degradation of discharge coefficient results from the solution viscoelasticity, which varies with polymer concentration and mixing history, and possibly was influenced also by the fairly rapid flow deformation time occurring in the short nozzle entrance. That the effect was not observed in the preliminary fire hose tests shown in Figure 1 may have been due to different viscoelastic properties of the freshly prepared (i.e., on-line) solution and/or the longer deformation time occurring in the tapered nozzle (1" tip) used. In any event, a thorough investigation of these parameters with respect to the jet "swelling" effect would be an interesting research investigation. However, since it was indicated that the more economical (from a polymer consumption standpoint) 300 ppm concentration was providing possibly optimum results, no further testing with the extremely high concentrations was attempted for this study.

## SIDE-BY-SIDE COMPARISON TESTS (0.525" NOZZLES)

The long, 0.525" nozzles were fabricated late in the study for use during the impact-pattern experiment to be described later. At the same time, a side-by-side comparison with a plain-water jet was made with the only polymer concentration prepared for that test sequence (320 ppm). Because of the higher flow rates associated with the larger-diameter tip, testing was done only with the 50 psi base pressure. While the jet exit velocity was still 86 fps as with the 0.25" tip, the flow rate was 4.4 times greater, as was the velocity in the 1½" pipe which fed the nozzle. Only a slight effect on coherence was observed; not at all like the obvious improvement obtained with the 0.25" nozzles.

More investigation would be required before one could confidently explain this turn of events based upon a single observation, and only conjectures can be offered here. One possibility is that the long, tapered, 0.525" nozzle was a more efficient design than the short 0.25" nozzle, so that the plain-water jet was better to start with and polymer additive could provide little improvement. Comparison measurements of the plain-water jets from the different nozzles during the impact-pattern experiment lends some credence to this possibility. As a correlative explanation, it may be that, even with identical nozzle designs and exit velocities, a larger diameter jet tends to be more coherent. This could be argued based upon the fact that the forward momentum in the jet varies as the square of the jet diameter, whereas the surface area upon which air drag acts varies as only the diameter directly.

Another conjecture is that the higher velocities (by a factor of 4.4) occurring in the feed pipe produced a turbulence level greater than could be suppressed by the polymer additive. It is, of course, true that many investigators have repeatedly shown polymer additives to be highly effective in reducing pipe-wall friction at the flow conditions seen here, with polymer concentrations substantially less than 320 ppm, and with the relative reduction in wall friction actually improving as the velocity increases. However, the large scale turbulence produced by the abrupt discontinuities at the nozzle entrance is quite different from the smaller scale turbulence acting along the pipe wall. While these step discontinuities were reduced when designing the 0.525" nozzle tip, the higher pipe-line velocities may have produced an intolerable (i.e. too intense for polymer suppression) large-scale turbulence situation. Further testing with smooth-bore, custom-machined nozzle assemblies of different tip sizes would address this possibility.

As a third conjecture, it may be that a higher polymer concentration would be required to stabilize the larger-diameter jet, as might be indicated by the preliminary experiment shown in Figure 1 which used a 1" nozzle tip. These conjectures are offered to possibly explain the different results obtained with two particular nozzle configurations. Caution must be exercised

in assuming only a diameter effect. Other variables must be isolated, and further investigation is required.

#### IMPACT PATTERN TESTS

The stream spray pattern, along with its sensitivity to wind, are difficult to show in a still photograph (although 8 mm movies taken at the time showed a true representation). In order to obtain some quantitative data, an impact pattern experiment was conducted with sampling cans. Figure 6 shows the test procedure. Sixty-five sampling cans (1-lb coffee cans) were arranged in 13 rows, five cans per row with a 10-inch spacing between centers, and 4 feet between rows. The entire can pattern was shifted in range to accommodate the flow stream obtained from the two different nozzles.

Separate tests were conducted for the plain water and polymer solution streams, rather than side-by-side comparisons, so dead calm wind conditions were awaited for each experiment. Each test was run for a controlled time interval, 8 minutes with a 0.25" nozzle and 3 minutes with the 0.525" nozzle. Following a test, the volume of water in each can was measured and tabulated. That volume was then corrected for the area of a can with respect to the ground impact area which the can represented (1:41). Because of the greatly elongated impact pattern, a substantial variation in range was observed, but little variation in width. Therefore, the captured samples in all five cans of each row were added, and the impact pattern plotted as a function of range only. The entire procedure proved to be quite reliable, with the integrated captured samples consistently accounting for 85 - 95% of the total flow.

Figure 7 shows results obtained with the 0.25" nozzle tip, with delivery patterns for plain water and a 320 ppm polymer solution superimposed. Plotted is the flow rate impacting per increment of distance from the nozzle versus distance from the nozzle. The tighter impact pattern at a greater range with polymer solution is clearly seen. Figure 9 shows a similar plot obtained with the 0.525" nozzle tip. While some improvement with polymer additive is seen, it is not near as substantial as obtained with the 0.25" nozzle. This comparison between the two nozzles is entirely consistent with observations made during the earlier side-by-side testing.

Note that the plain water pattern peaked at a range of 55 ft with the 0.25" nozzle, and 99 ft with the 0.525" nozzle. The theoretical trajectory range, assuming a stream in a vacuum, would be 148 ft for either nozzle (identical base pressures and inclinations). As mentioned previously, this might indicate that the larger diameter nozzle was a more efficient design and/or a larger diameter jet tends to be more coherent (other things being equal).

These delivery patterns were separately replotted in Figs. 8 and 10, and graphically integrated in order to obtain quantitative

comparisons. Integrated saturation zones are shown for each delivery pattern, and these can be defined as the smallest area upon which 50% of the total flow rate impacts. Comparison calculations are shown on each figure. Figure 8 shows that for the 0.25" nozzle; the saturation zone with polymer additive impacts at a 7% greater range, the zone is 31% smaller or "tighter", and the saturation or "rain" rate is increased by 45%. As seen in Fig. 10, the improvements achieved with the 0.525" nozzle are less impressive with the saturation zone range, size, and "rain" rate being improved by only 1%, 6%, and 6% respectively.

#### SUMMARY

Preliminary experiments were conducted to study the effect of water-soluble polymer additives on the coherence of nozzle streams. Most testing was done with a 0.25" nozzle tip at base pressures of 50 and 100 psi, and with four different concentrations of Polyox WSR-301. The most effective concentration appeared to be 300 ppm, which produced a transparent rod-like jet near the nozzle and substantially reduced breakup at the maximum stream height. On the other hand, viscoelastic properties of the thickened 6800 ppm solution caused jet swelling and early disintegration of the stream.

A second nozzle with a 0.525" tip was tested at the single concentration of 320 ppm, but improvements to the jet stream were substantially less than observed with the smaller nozzle. Several conjectures are offered to explain this single observation, and caution must be exercised in assuming a diameter effect alone. In particular, abrupt discontinuities in the nozzle entrance may have prevented meaningful comparisons, and further testing with smooth-bore nozzles is recommended.

Quantitative data were obtained from sampling cans, and this testing showed an increase in stream throw and a reduction in the stream dispersion pattern. Casual observations showed the relative stream improvement to be enhanced under wind conditions.

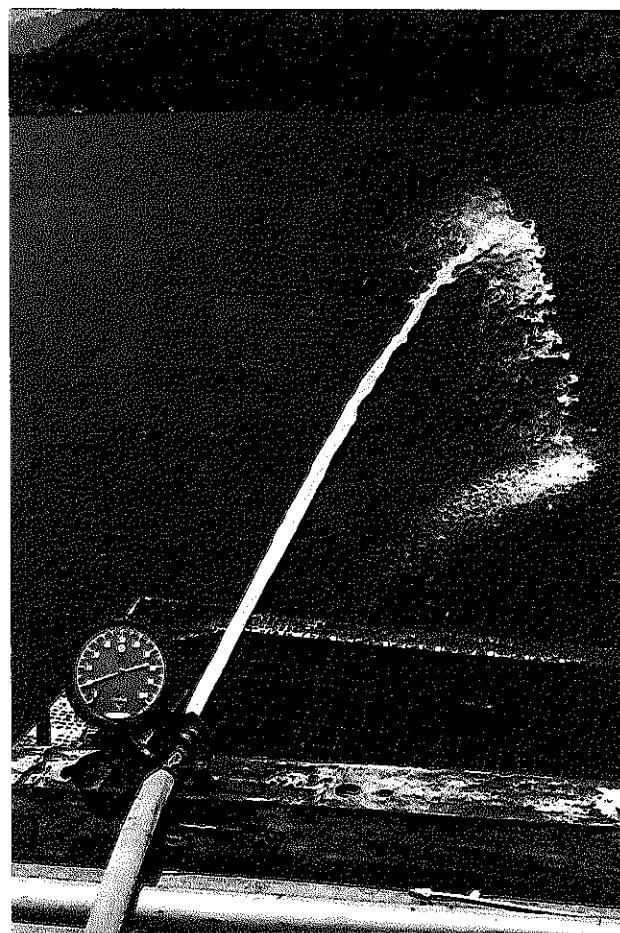
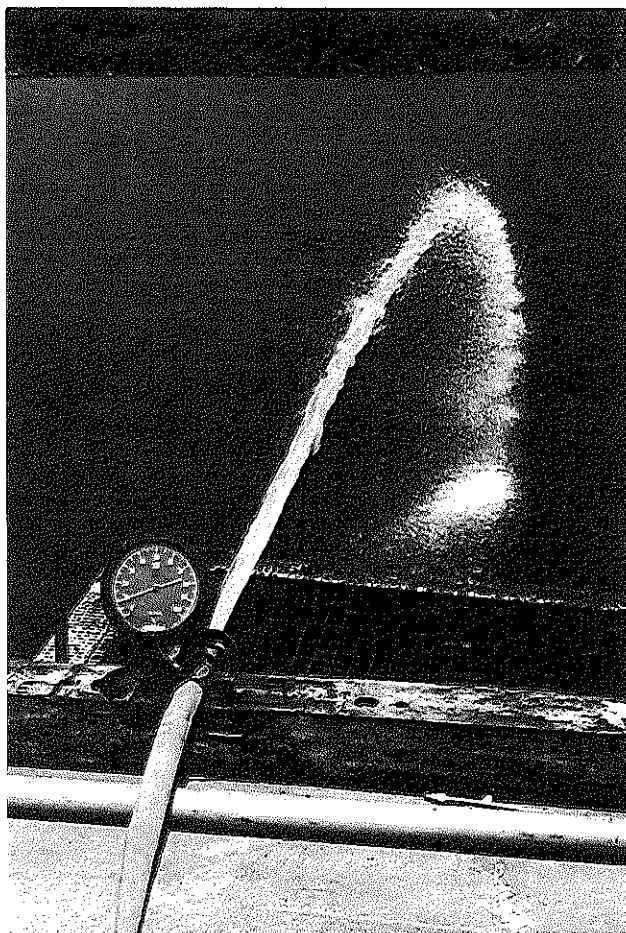

FIG. 1. Preliminary Test with 1-1/2-inch Fire Hose.

(Left) Plain Water.

(Right)  $\approx 1.0\%$  Polyox Solution Prepared On-Line with Slurry Injection.

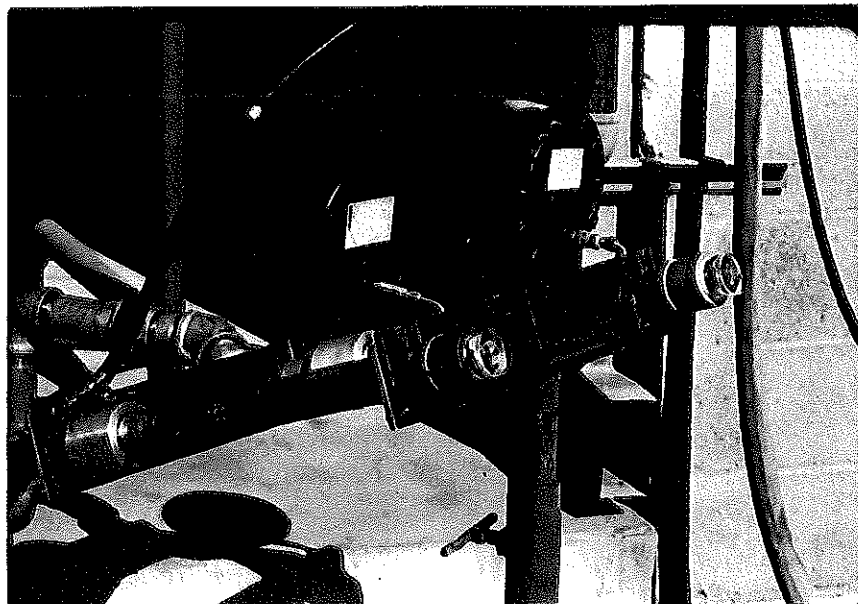
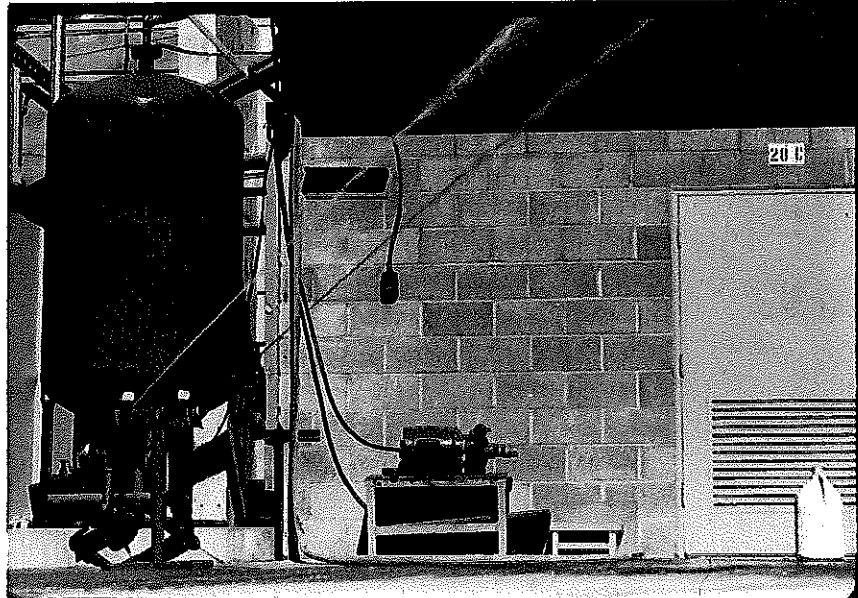

FIG. 2. Nozzle Test Setup.

(Top) Note 550-Gallon Pressurized Polymer Solution Tank Feeding One Nozzle. Water Main Feeds Second Nozzle.  
(Bottom) Note Pressure Gage at Each Nozzle Base. 0.25-inch Tips Installed.

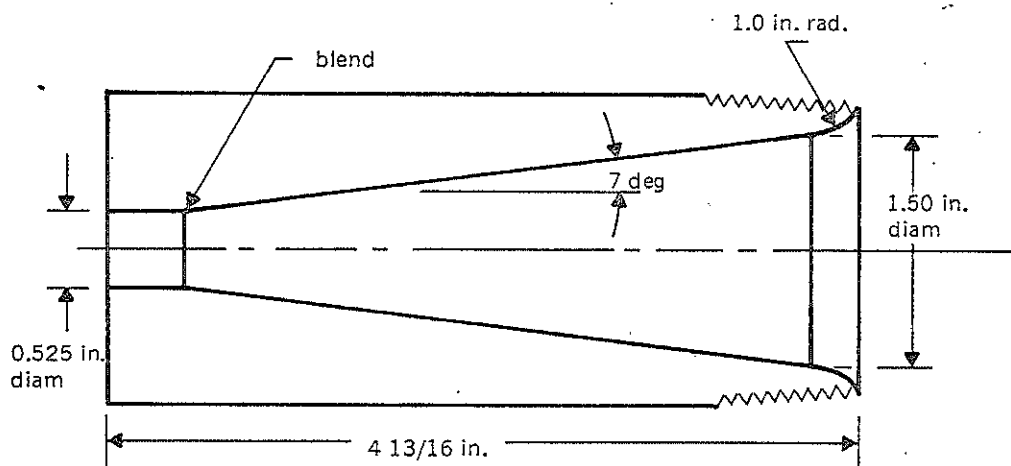
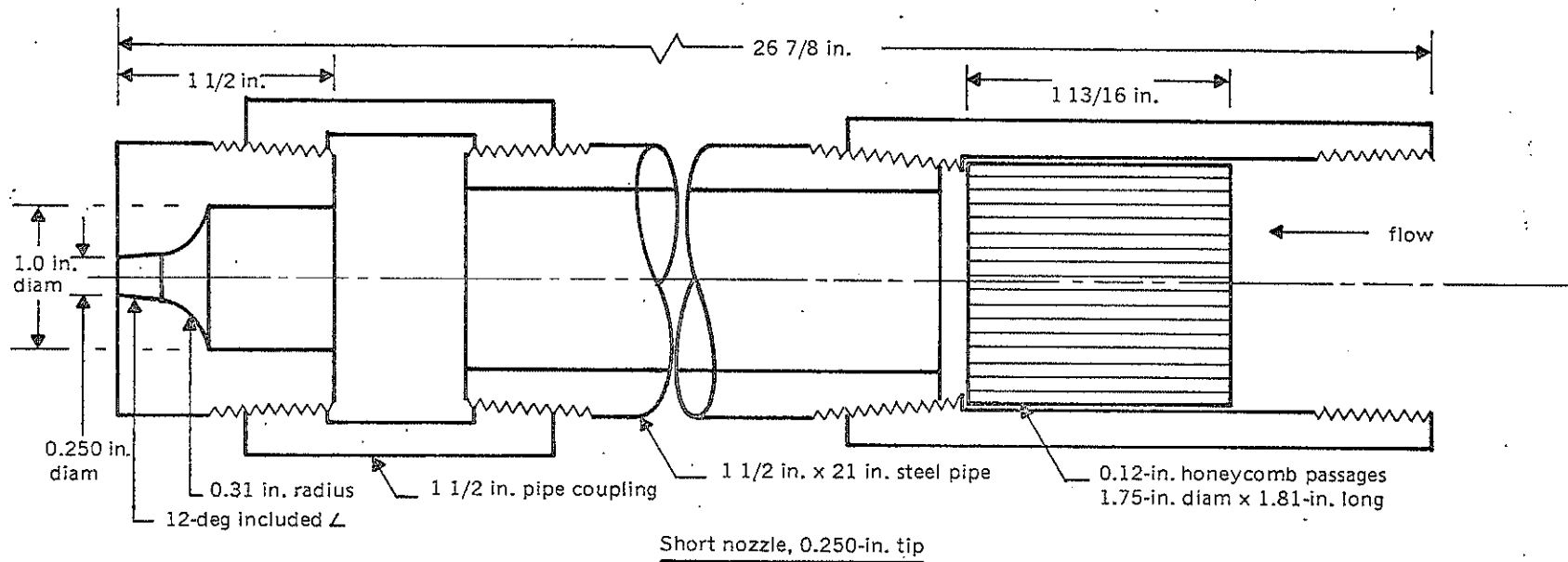

Figure 3

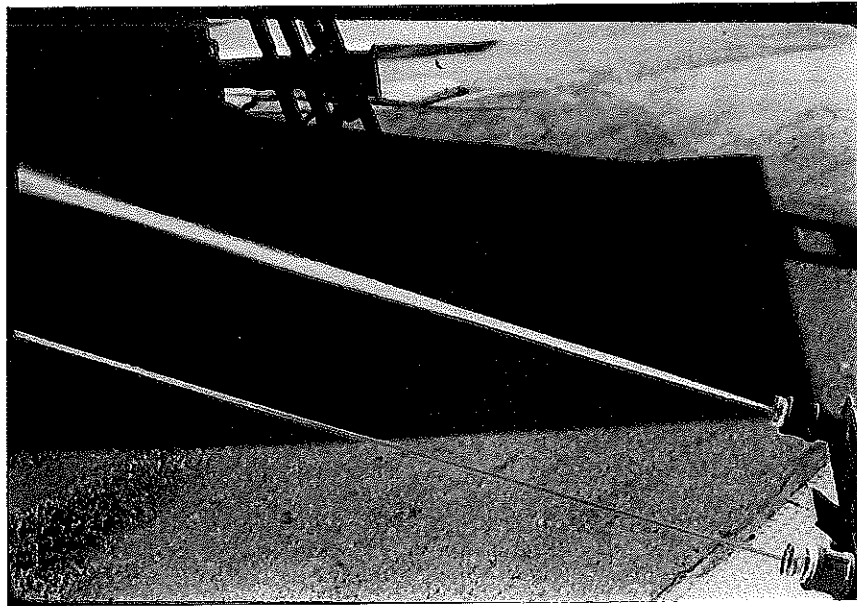
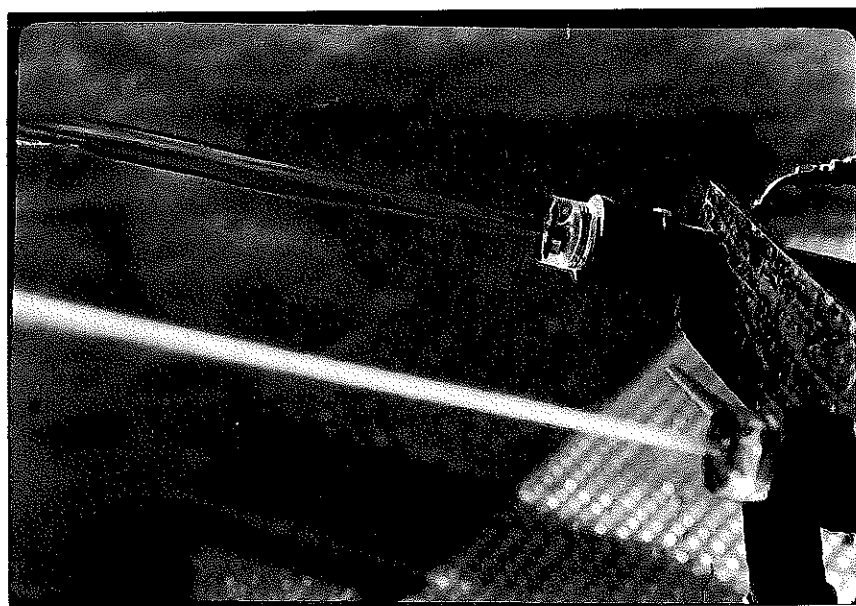

FIG. 4. Evaluating 290 ppm Polyox Solution with 0.25-inch Nozzle Tip.  
(Top) Note Spray from Water Stream on Right.  
(Bottom) Note Rod-Like Polymer Stream from Lower Nozzle.



**FIG. 5.** Testing Thick (6,800 ppm) Polyox Solution with 0.25-inch Nozzle Tip.  
(Top) Note Polymer Stream Breakup in String-Like Ligaments.  
Nozzle Discharge Coefficient Half of That with Water.  
(Bottom) Note Polymer Stream Expansion Upon Leaving Nozzle.

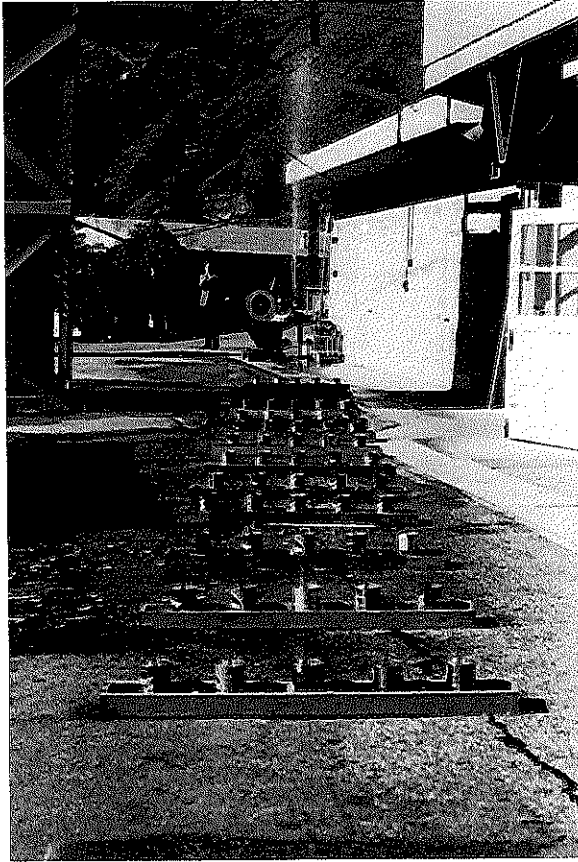

FIG. 6. Sampling Can Pattern. Five Cans per Row with 10-inch Spacing.  
Thirteen Rows with 4-foot Spacing Between Rows.  
(Left) Looking Upstream.  
(Right) Looking Downstream.

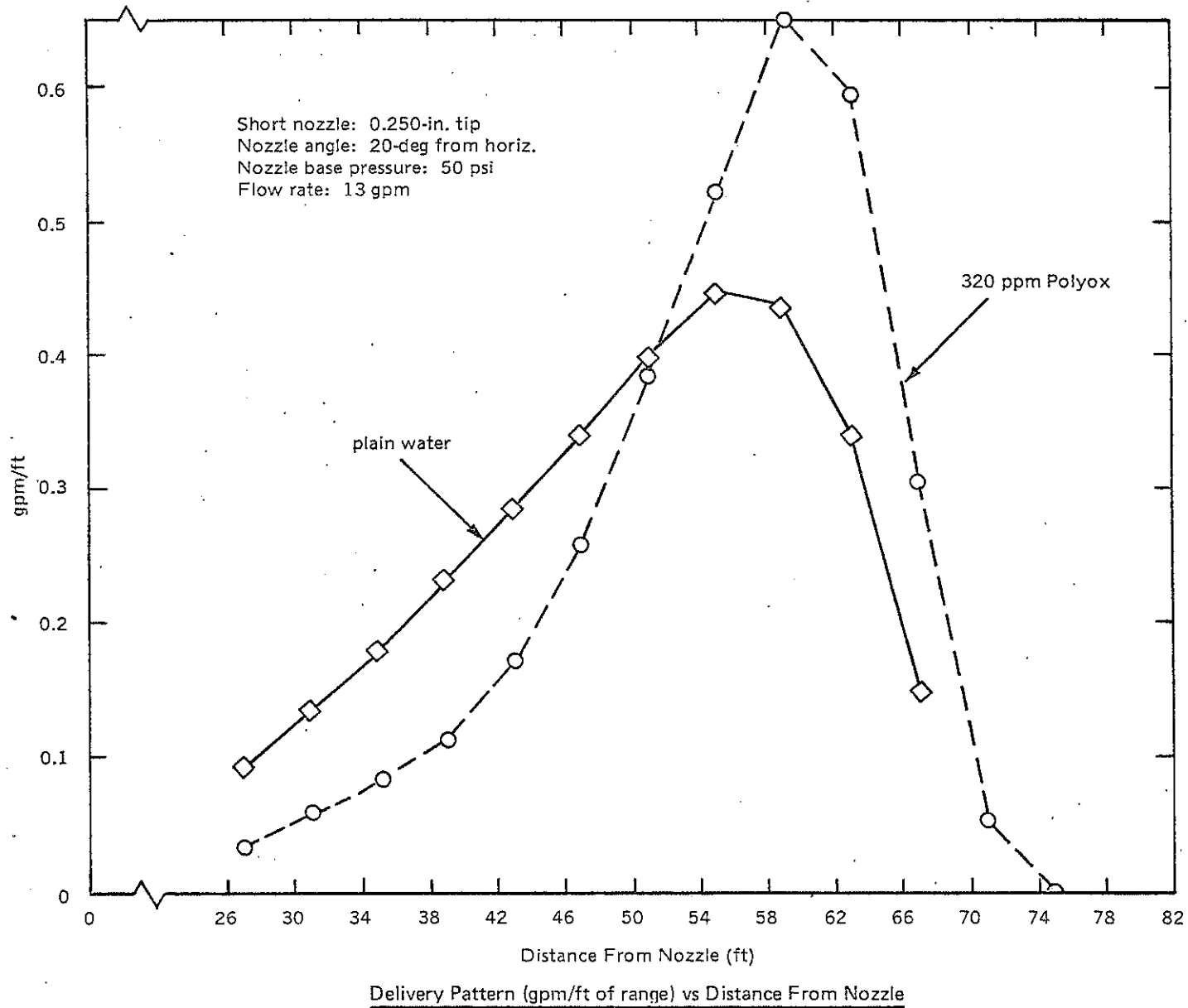

Figure 7

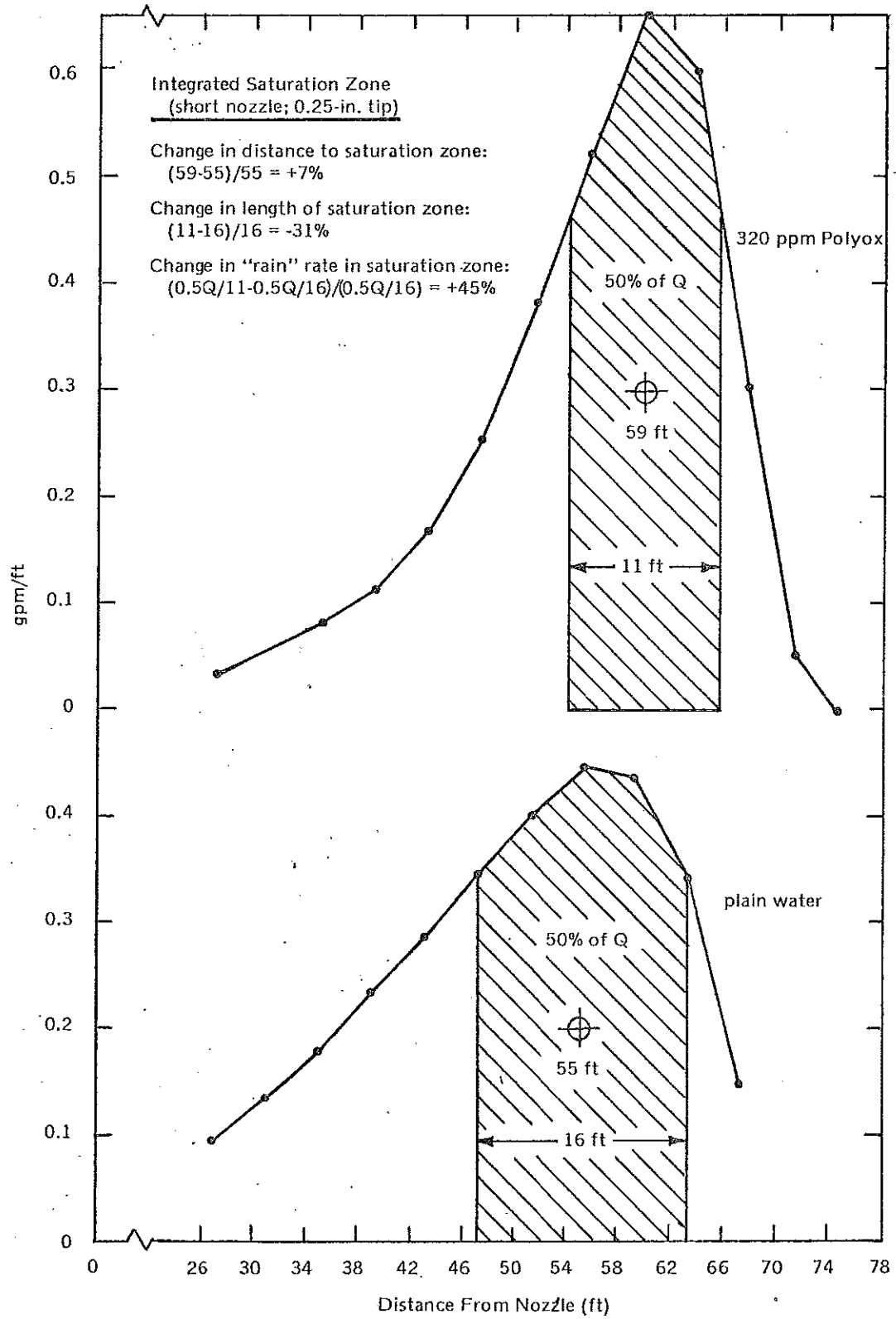
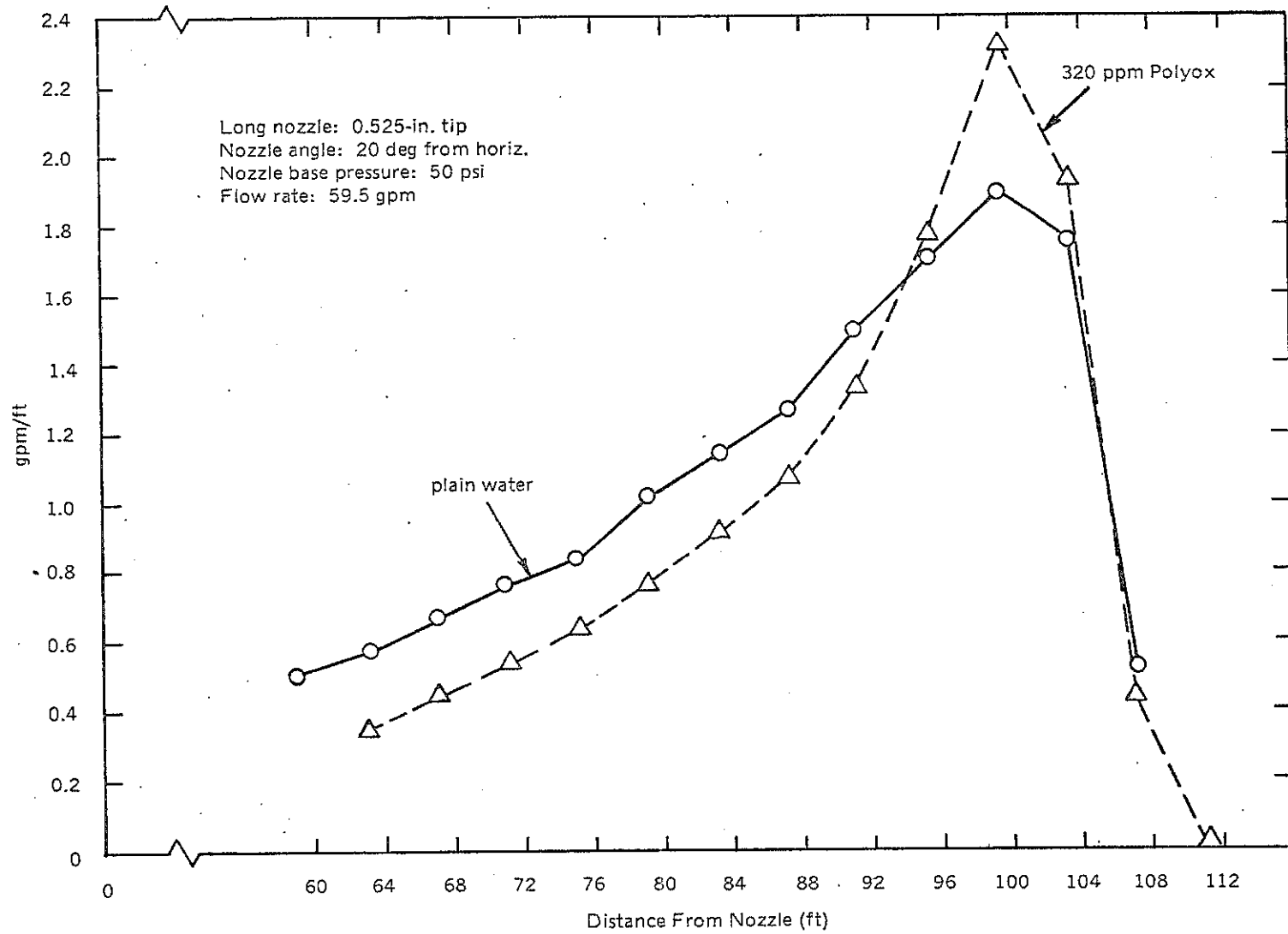

Figure 8



Delivery Pattern (gpm/ft of range) vs Distance From Nozzle

Figure 9

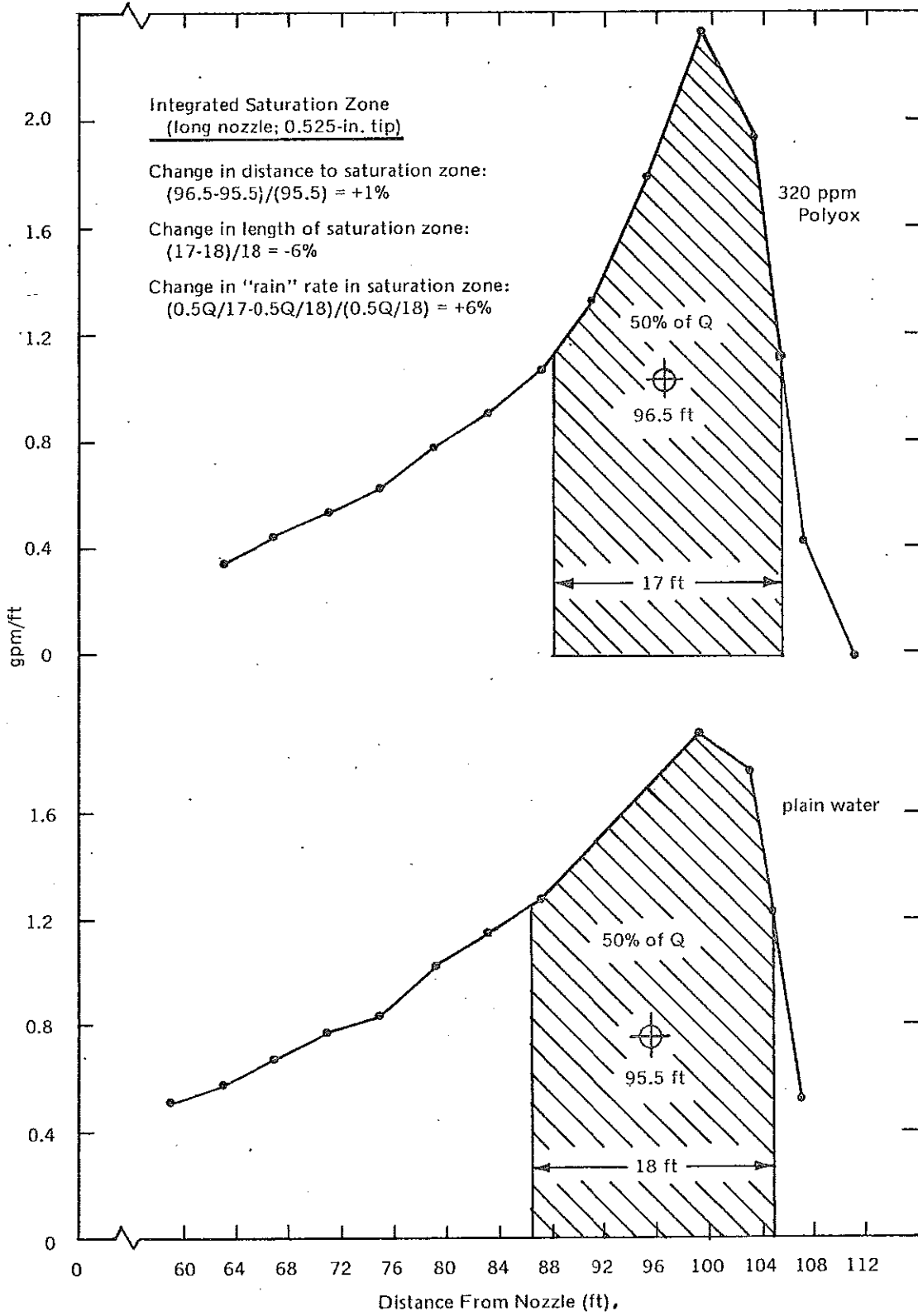

Figure 10