



**US Army Corps
of Engineers®**
Engineer Research and
Development Center



Scour Level II Assessment of U.S. Army Installation Bridge

Facility Number: BRG15 Fort Stewart, Georgia

Sheila M. Arias-Román and Deborah Suazo-Dávila

March 2019



The U.S. Army Engineer Research and Development Center (ERDC) solves the nation's toughest engineering and environmental challenges. ERDC develops innovative solutions in civil and military engineering, geospatial sciences, water resources, and environmental sciences for the Army, the Department of Defense, civilian agencies, and our nation's public good. Find out more at www.erdcl.usace.army.mil.

To search for other technical reports published by ERDC, visit the ERDC online library at <http://acwc.sdp.sirsi.net/client/default>.

Scour Level II Assessment of U.S. Army Installation Bridge

Facility Number: BRG15 Fort Stewart, Georgia

Sheila M. Arias-Román and Deborah Suazo-Dávila

*Geotechnical and Structures Laboratory
U.S. Army Engineer Research and Development Center
3909 Halls Ferry Road
Vicksburg, MS 39180*

Final report

Approved for public release; distribution is unlimited.

Prepared for Headquarters Installation Management Command (IMCOM)
2405 Gun Shed Road, Fort Sam Houston, TX 78234-1223
Under Project Number 154349

Abstract

The most common cause of bridge failure is flood scouring of the streambed material from around the structure's foundations. Several researchers have suggested that the leading cause of bridge collapse is scour. This is the engineering term used to describe the natural process that involves the removal of sediment from around the bridge's structure, such as abutment walls and pier columns, and from the bottom and sides of the streambed due to the flow of water. The aim of this project is to develop analytical calculations by using acquired data to determine scour depth for 100-year and 500-year events or overtopping floods. The current method implemented to predict the scour depth for U.S. Army bridges is based on the general guidelines within the Hydraulic Engineering Circulars (HECs) No.18 and No.20 recommended by the Federal Highway Administration (FHWA). Bridge scour is a combination of natural processes that involves hydrology, river hydraulics, geomorphology, and the geometry of the structures. Hence, in order to implement the current procedure, it was necessary to perform reviews of historical field channel profiles, hydrologic analysis based on rainfall events at the bridge location, hydraulics assessment based on the flood flow, and laboratory testing of soil properties. Water-surface profiles and the components of scour depths -- such as total scour, contraction scour, and pier and abutment scour -- were determined for the bridge.

DISCLAIMER: The contents of this report are not to be used for advertising, publication, or promotional purposes. Citation of trade names does not constitute an official endorsement or approval of the use of such commercial products. All product names and trademarks cited are the property of their respective owners. The findings of this report are not to be construed as an official Department of the Army position unless so designated by other authorized documents.

DESTROY THIS REPORT WHEN NO LONGER NEEDED. DO NOT RETURN IT TO THE ORIGINATOR.

Contents

Abstract	ii
Figures and Tables	iv
Preface	v
Unit Conversion Factors	vi
1 Introduction	1
1.1 Purpose and scope.....	2
1.2 Background.....	2
2 Literature Review	5
3 Study Site	9
4 Level 1: Qualitative Assessment	11
4.1 Evaluation of land uses.....	11
4.2 Stream characteristics	11
4.3 Overall stream stability.....	12
5 Level II: Quantitative Assessment	14
5.1 Estimation of flood magnitude	14
5.2 Bed and bank material evaluation	15
5.3 One-dimensional hydraulic model	16
5.4 Scour assessment.....	20
6 Conclusion and Recommendations	22
References	23
Appendix A: Bridge BRG15 Sketches	25

Figures and Tables

Figures

Figure 1. Location of the Bridge BRG15 site at Fort Stewart, GA.	9
Figure 2. Bridge BRG15 watershed.....	10
Figure 3. Channel profile for the upstream section of the bridge crossing.	12
Figure 4. Channel profile for the downstream section of the bridge crossing.	13
Figure 5. Grain-size distribution of the Canoochee River soil at the bridge site.	16
Figure 6. Water-surface profile from (a) upstream cross section and (b) downstream cross section.....	19

Tables

Table 1 . Year recurrence with corresponding peak flows estimates.	15
Table 2. Summary of the one-dimensional hydraulic characteristics results.....	18
Table 3. Contraction and abutment scour computations for Bridge BRG15 at Fort Stewart, GA.	21
Table 4. Pier scour depth estimate for Bridge BRG15 at Fort Stewart, GA.....	21

Preface

This study was conducted for the Headquarters, Installation Management Command (IMCOM), Army Transportation Infrastructure Inspection Program (ATIIP) under the Bridge Safety Program Scour Evaluation and Structure Risk Analysis. The IMCOM Program Manager was Mr. Michael R. Andres.

The work was performed by the Structural Engineering Branch (GSS) of the Geosciences and Structures Division (GS), U.S. Army Engineer Research and Development Center, Geotechnical and Structures Laboratory (ERDC-GSL). At the time of publication, Dr. Jay Shannon was Acting Chief, CEERD-GSS; and Mr. James L. Davis was Chief, CEERD-GS. The Deputy Director of ERDC-GSL was Mr. Charles W. Ertle II, and the Director was Mr. Bartley P. Durst.

COL Ivan P. Beckman was the Commander of ERDC, and Dr. David W. Pittman was the Director.

Unit Conversion Factors

Multiply	By	To Obtain
cubic feet	0.02831685	cubic meters
degrees (angle)	0.01745329	radians
degrees Fahrenheit	$(F-32)/1.8$	degrees Celsius
feet	0.3048	meters
inches	0.0254	meters
miles (US statute)	1,609.347	meters
square feet	0.09290304	square meters
square miles	2.589998 E+06	square meters

1 Introduction

Since most of the recent bridge failures in the United States are related to scour conditions, the Federal Highway Administration (FHWA) has requested that every bridge in the nation be evaluated and analyzed not only for structural capacity but also for the structure-stream interaction (FHWA 1991). In fact, many of the bridge failures are not due to structural problems, meaning that these failures are produced by factors not related to the structures' capacity to carry load properly. Several studies have suggested that the principle responsible for bridge damage and collapse is scour. This is the engineering term used to describe the natural process that involves the removal of sediment both from around the bridge's structure, such as abutment walls and pier columns, and from the bottom and sides of the streambed due to the flow of water. This is a negative behavior, considering that the bridge's structures are exposed. Consequently, the structure becomes more susceptible to loss capacity and eventually failure by scour.

The main objective of a scour evaluation is to identify the susceptibility of erosion of the streambed material and the magnitude of the bridge's foundation stability. The current available bridge scour evaluation program implemented for U.S. Army bridges was developed in accordance with National Bridge Inspection Standards (NBIS) and FHWA guidance and includes two categories (Suazo et al. 2013). The first category, known as Level I evaluation, is the qualitative assessment; and the quantitative assessment, termed Level II, is the second category.

In the qualitative assessment (Level I), bridges are visually inspected in order to identify potential scour. This level of evaluation is based in the geomorphic characteristics of the stream and is developed by obtaining data from a field site visit. The data collected in the Level I evaluation includes stream characteristics; a streambed cross-section profile; overall stream stability, including lateral and vertical stability; and historical land use and changes in order to know all the conditions and variations of the stream's stability. Each of these essential components in Level I conglomerates in six steps. Conclusions from Level I assessment are the fundamental bases from which to proceed to Level II. If the results in the qualitative analysis demonstrate that the bridge is not vulnerable to suffer

scour, the quantitative evaluation is not necessary. Nevertheless, if the culvert or the bridge is likely to scour, a Level II assessment should be performed to identify the critical condition for the structure.

The Level II assessment is more complex than the qualitative evaluation since it requires knowledge of the hydrologic process, hydraulic studies, and sediment transport of the stream. This assessment is significant in this project, since the bridge scour depth is determined in this evaluation. There are several methods for the Level II analysis, but many of them require extensive information, such as the history of flooding, hydrological conditions, and geomorphology characteristics.

1.1 Purpose and scope

The USACE-ERDC Bridge Inspection Team is responsible for performing a Level II evaluation to the bridges on the U.S. Army installation's inventory identified in the Scour Level I Field Evaluation as having a high degree of vulnerability and probability to suffer scour. As a consequence, the purpose of this report is to describe the scour assessment for an existing bridge crossing a waterway in the Army installation at Fort Stewart, GA. The aim of the evaluation is to predict scour depths due to floods in the magnitude of 100- and 500-year events or an overtopping flood. In order to represent the physical conditions of the river, a wide range of data related to the hydrologic, hydraulic, and soil characteristics was collected. In this study, a one-dimensional hydraulic model was used to estimate and simulate the velocity and the water-surface elevations through the bridge opening.

The specific objectives of the study were to (1) review historical data of scour retrieved from field measurements; (2) develop a drainage basin for the selected bridge with data obtained through remote sensing; (3) determine the necessary hydraulic parameters, such as velocity and flow depths, for estimating scour depths at piers and abutments; (4) estimate the flood flow that is likely to yield the most severe scour; and (5) report an analytical assessment for vulnerabilities and risk of failure due to scour.

1.2 Background

The scour at bridges consists of many difficult hydraulic stages producing the erosive action of water. A very intense rate of change of the position of the water has the capacity to remove the soil from the bed and banks of the stream. Furthermore, it can remove the streambed material surrounding

the piers and abutments of bridges. This process increases the risk of failure of the bridge, considering that the piers and abutments are exposed. As a result, the structure will be more susceptible to losing capacity and eventually failing.

The total scour at highway structures such as bridges consists of local scour, long-term aggradation or degradation scour, and general scour (Arneson et al. 2012). Each of these components involves a different independent scour process; therefore, this behavior can have significant diverse effects on the structure. The long-term aggradation and degradation scours implicate streambed elevation changes that are less relevant in the scour analyses. Indeed, many scour analyses focus only on the determination of contraction and local scour factors (Holnbeck and Parrett 1997).

The long-term streambed elevation changes comprise two processes known as aggradation and degradation scour. This scour component occurs when the stream channel elevation over time is reduced or increased due to natural causes or consequences of human alterations or activities. The long-term elevation change is not a process related to effects such as runoff event, which are caused by flooding (Arneson et al. 2012). In this process the removal of sediment is due to the river flow. Long-term aggradation involves deposition of eroded sediment and, consequently, an increase in the elevation of the bed. On the other hand, degradation implicates removal of material across the streambed; therefore, the channel will have a decrease in the bed elevation.

There are many components of general scour, but the most common is contraction scour. This component results from an increase in the velocity of the stream when the stream flow area is reduced at the bridge opening. Depending on whether there is a transport of bed material or not, the scour can be live-bed contraction or clear-water contraction. When there is no bed material transport from upstream to downstream or when the material is transported in suspension, the contraction scour is clear water (Richardson and Davis 2001). However, if the upstream flow is transporting bed material, the contraction scour is live bed.

The obstruction of the upstream flow by a bridge's structure, such as abutment walls and pier columns, generates a vortex that can remove sediment surrounding these structures. This process is better known as

local scour. Depending on whether the removal is around the pier or the abutment, local scour can be pier scour or abutment scour. Pier scour is caused by horseshoe vortex action produced by an acceleration of flow around the pier. These vortices can remove streambed material from the base of the pier, therefore creating scour holes. The abutment scour is produced by horizontal and vertical vortices that can take away the sediments around these structures. The horizontal vortex can cause a scour hole at the toe of the abutment, and the vertical wake vortex can produce erosion on the downstream side of the abutment (Richardson and Lagasse 1999).

2 Literature Review

The effect of flooding is very significant on bridges, considering that 60 percent of these structures in the United States have failure for this reason (Carpenter and Miller 2011). Intense flooding can cause the river or the stream that passes under the bridge to overflow, increasing its velocity and producing severe hydraulic forces that can affect the bridge's foundation. The result of the interaction of these forces with the streambed is the removal of sediment that is important to support the structure. In engineering this process, known as bridge scour, has become a noteworthy concern in the United States, since any bridge over a waterway is susceptible to experiencing critical floods capable of scouring the bed material.

From 1960 to the present, numerous bridge failures and collapses have resulted from scour. Approximately 83 percent of the 583,000 bridges in the National Bridge Inventory are built over waterways (Richardson and Davis 2001). In 1985, 73 bridges were destroyed or damaged by scour resulting from floods in Pennsylvania, Virginia, and West Virginia (Mueller et al. 1994). More than 2,500 bridges were severely affected by scour caused by flooding in 1993 (Mueller and Wagner 2002). In 1989, eight people were killed when the U.S. Route 51 bridge over the Hatchie River in Tennessee failed because of a lateral shift of the stream (Mueller et al. 1994).

The consequence of bridge scour is a serious problem that can affect a nation in different ways; however, it was not until 1988 that the FHWA proposed that every bridge over a scourable stream, whether existing or under design, be evaluated as to its vulnerability to floods in order to determine the prudent measures be taken for its protection. This requirement created the urgency to develop a method that could estimate and predict the behavior of floods scouring the bed material in the vicinity of and around bridge foundations.

Scour prediction is a principal component in the design process and maintenance of bridges. Several academic institutions and the Departments of Transportation (DOT) of different states have been developing numerical and empirical models to calculate scour depth. However, the most widely used procedure for bridge scour evaluation is based on the manuals provided by the FHWA: *Hydraulic Engineering*

Circulars (HECs) No. 18 and No. 20 (Arneson et al. 2012; Lagasse et al. 2012). HEC-18 provided tools to predict scour depth that were developed from laboratory flume investigation with field data. The results of the investigation were several empirical equations that could be used to compute the components of scour depth -- such as contraction scour, pier scour, and abutment scour -- at bridges.

Currently, there are five editions of the HEC-18 manual, and it is the principal procedure used by the DOTs for scour analysis that includes the design and inspection of bridges. Application of the scour prediction equations requires a detailed hydraulic analysis at the bridge site that comprises flood discharge, hydraulic characteristics, and water-surface elevations. The flood flow applied in the method is the one that is expected to yield the most severe scour conditions -- such as the 100-year and 500-year flood events or the discharge that can produce road overtopping. A brief description of the scour equations within the HEC-18 method is provided below.

Contraction scour can occur under two conditions: clear water, which takes place when the upstream flow is not transporting sediments, or live bed, which occurs when the upstream flow is transporting bed material. The development of both equations is based on the principle of conservation of sediment transport. The live-bed scour is computed with the equation

$$\frac{y_2}{y_1} = \left(\frac{Q_2}{Q_1} \right)^{\frac{6}{7}} \left(\frac{W_1}{W_2} \right)^{k_1} \quad (1)$$

where:

y_1 = average depth in the upstream main channel, in ft,

y_2 = average depth in the contracted section, in ft,

Q_2 = flow in the contracted channel, in ft³/s,

Q_1 = flow in the upstream channel, in ft³/s,

W_2 = bottom width of the contracted section less the pier width, in ft,

W_1 = bottom width of the upstream channel, in ft, and

k_1 = factor in function of the fall velocity of the bed material and shear velocity.

According to Arneson et al. (2012), the clear-water scour equation is based on the equation developed by Laursen,

$$y_2 = \left(\frac{K_u Q^2}{D_m^{2/3} W^2} \right)^{3/7} \quad (2)$$

where:

y_2 = average depth in the contracted section, in ft,

Q = flow through the bridge or on the set-back overbank area at the bridge associated with the width W , in ft³/s,

D_m = diameter of the smallest nontransportable particle in the contracted section, in ft,

k_u = 0.0077, and

W = bottom width of the contracted section less the pier width, in ft.

Local pier scour is a function of several properties -- such as geometry of the pier, bed material, flow characteristics, and bed configuration. This scour component is computed as follows:

$$\frac{y_s}{a} = 2K_1 K_2 K_3 \left(\frac{y_1}{a} \right)^{0.35} Fr_1^{0.43} \quad (3)$$

where:

y_s = scour depth, in ft,

y_1 = flow depth upstream of the pier, in ft,

K_1 = correction factor for pier nose shape,

K_2 = correction factor for angle of attack of flow,

K_3 = correction factor for bed condition,

a = pier width, in ft, and

Fr_1 = Froude number upstream of the pier.

In the HEC 18 method, the abutment scour can be estimated using two different equations according to the field conditions. The first equation is the Froehlich's abutment scour equation,

$$\frac{y_s}{y_a} = 2.27K_1K_2 \left(\frac{L'}{y_a}\right)^{0.43} Fr^{0.61} + 1 \quad (4)$$

where:

- y_s = scour depth, in ft,
- y_a = flow depth of flow on the floodplain, in ft,
- K_1 = correction factor for abutment shape,
- K_2 = correction factor for angle of embankment to flow,
- L' = length of active flow obstructed by the embankment, in ft,
- Fr = Froud number upstream of the abutment.

The other equation is the HIRE (Highways in River Environment) abutment scour equation, which is based on scour field data at the Mississippi River. The local abutment scour is determined as follows:

$$\frac{y_s}{y_1} = 4Fr^{0.33} \frac{K_1}{0.55} K_2 \quad (5)$$

where:

- y_s = scour depth, in ft,
- y_1 = flow depth at the abutment on the overbank or in the main channel, in ft,
- K_1 = correction factor for abutment shape,
- K_2 = correction factor for angle of embankment to flow,
- Fr = Froud number based on the velocity and depth adjacent to and upstream of the abutment.

A more detailed description of the scour depth equations and coefficients is provided in the fifth edition of *Evaluating Scour at Bridges* (HEC-18; Arneson et al. 2012).

3 Study Site

The Level II scour assessment was conducted for the facility number BRG15 at Fort Stewart, GA. Bridge BRG15 is over the Canoochee River in the southeast part of Georgia. Bridge BRG15's location is presented in Figure 1. The river is about 90 miles long upstream from the bridge, and the reach that is the subject of this research has a length of approximately 8 mi. The bridge was built in 1993 and consists of timber stringers, and the superstructure is supported by timber piles. The total length of 225 ft is composed of 16 simple spans, each with a length of 14 ft and a width of approximately 22 ft. The bridge deck has an average elevation of 67 ft above the North American Vertical Datum (NAVD 88). Detailed sketches of the bridge are provided in Appendix A.

Figure 1. Location of the Bridge BRG15 site at Fort Stewart, GA.

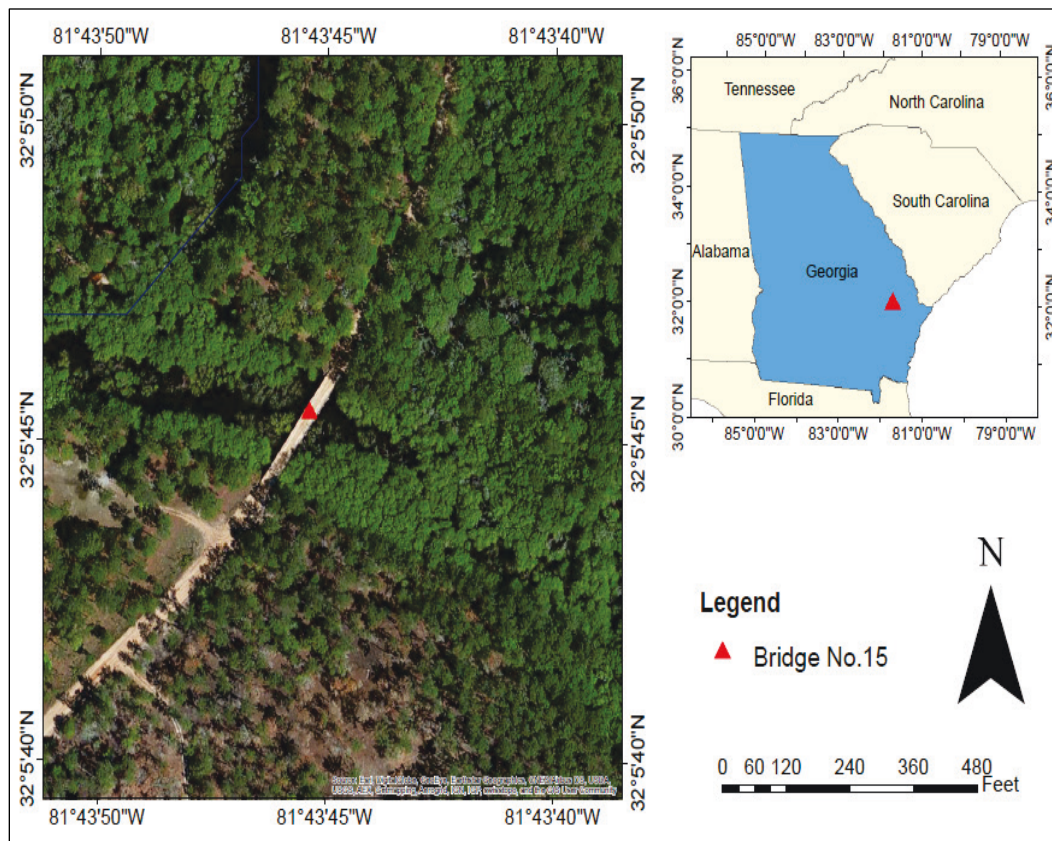

The Bridge BRG15 watershed encompasses 930 sq mi in five counties: Bulloch, Candler, Emanuel, Evans, and Tattnall. The watershed is shown in Figure 2. The area is mainly covered with mixed forest and woody wetlands, especially in the downstream part. The climate is mostly subtropical humid

with an annual precipitation averaging between 46 and 50 in. (NOAA 2008). The climate is characterized by mild winters and hot summers. The maximum average yearly temperature exceeds 90 deg, and the minimum mean annual temperature ranges from 52°F to 55°F (NOAA 2008).

Figure 2. Bridge BRG15 watershed.

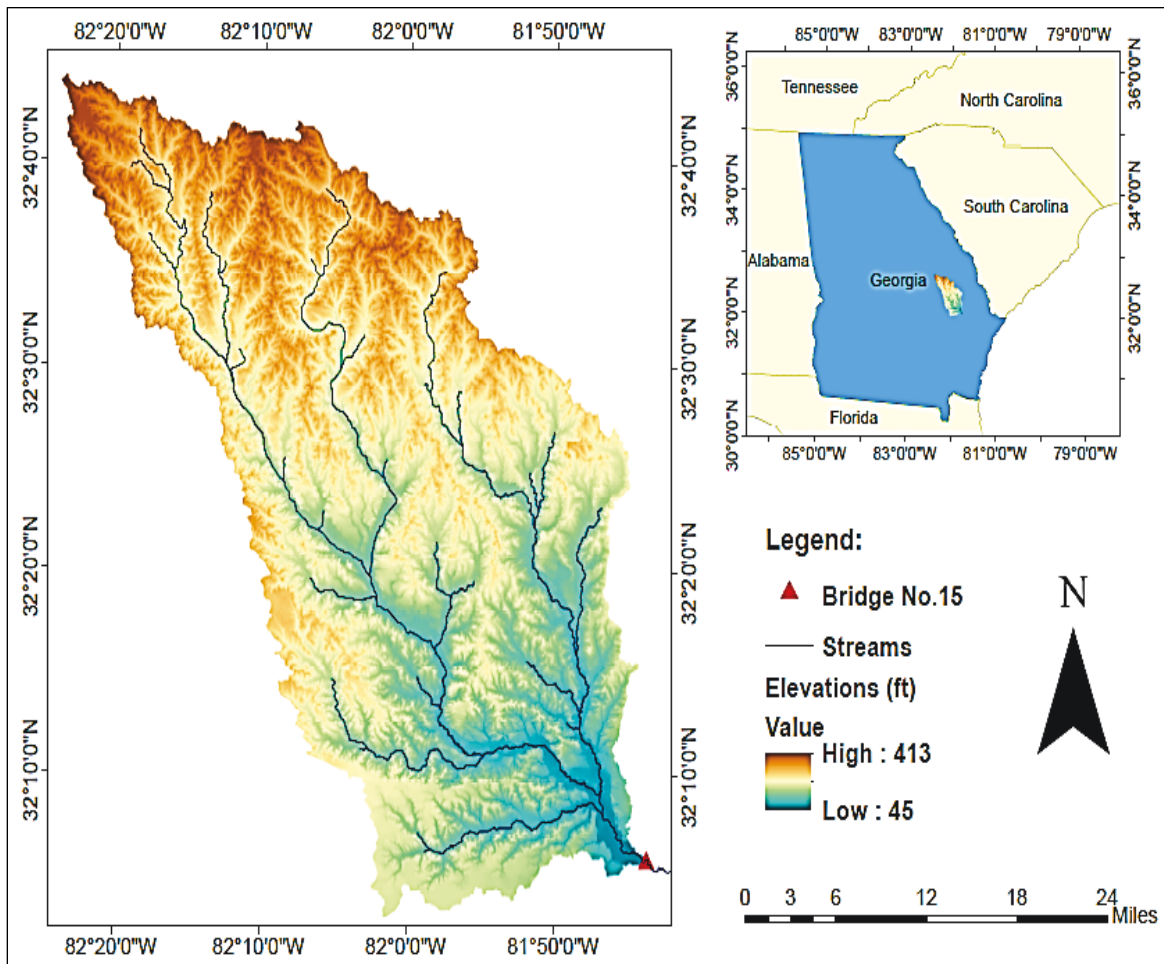

4 Level 1: Qualitative Assessment

A qualitative assessment provides valuable information needed in order to identify bridges vulnerable to suffer scour as low risk, scour susceptible, or scour critical. Significant characteristics at the bridge location result from the procedure implemented in the potential scour examination that helps determine the qualitative condition of the structure. The Level 1 assessment comprises factors that can increase the risk of scour -- such as stream characteristics, land use, and overall stream stability. Hence, the analyses reported herein are based on the data obtained from office review and a field visit at the bridge site.

4.1 Evaluation of land uses

In this analysis, information regarding the land uses and land cover of the area of interest was obtained from the National Land Cover Database 2011 (Homer et al. 2015). The NLCD information was validated using satellite imagery with Landsat data. The land cover and land use were classified in several principal categories: developed (open space, low/medium/high intensity), forest (mixed, evergreen, and deciduous), cultivated crops, and woody wetlands. The land use also includes a developed class that is not a major land use type, since the study site contains less than 10 percent of that class. Furthermore, the land use within the region is very limited, since most of it is surrounded by forest, cultivated crops, and woody wetlands.

4.2 Stream characteristics

At the study area, Bridge BRG15 at Fort Stewart crossed the lower part of the Canoochee River. At the bridge opening, the river is considered a medium stream, since the bank-to-bank width is approximately 200 ft with an average slope of 2.35 ft/mi. In general, the Canoochee River is classified as a perennial stream; however, the section approaching the bridge may experience droughts during the summer time. The river, identified as meandering, crossed under the bridge from west to east at an angle of attack of 30 deg and is categorized with a relatively narrow floodplain. In the river channel and banks, the vegetation consists of a mixture of large and small trees. Furthermore, the trees are a significant obstruction in the segment of the channel approaching the bridge.

4.3 Overall stream stability

The overall stream stability is based on existing data collected either from field observations or from bridge inspection records. The river stability is a critical component to define the vulnerability directly related with bridge scour. Typically, channel profiles are a very useful illustration that can provide chronological changes of the channel bed elevation at the structure crossing. Streambed elevation measurements upstream and downstream from the bridge were collected in 2011, 2013, and 2016. Significant changes in elevations were encountered in a review and comparison of the historical cross section.

As shown in Figures 3 and 4, the more unstable section of the bed is located near the left abutment looking downstream (the area between 14 and 84 ft) in which a decrease of the bed material up to 8 ft was present in some bents. The depths related with the 2013 measurements are an indicator of the contraction and pier scour condition throughout the structure. However, increases in the elevations were identified in the 2016 profile, suggesting an aggradation process under the bridge. In general, the qualitative analysis provides an understanding of the potential scour problems at the Bridge BRG15 site and the necessity of performing a detailed Level II assessment.

Figure 3. Channel profile for the upstream section of the bridge crossing.

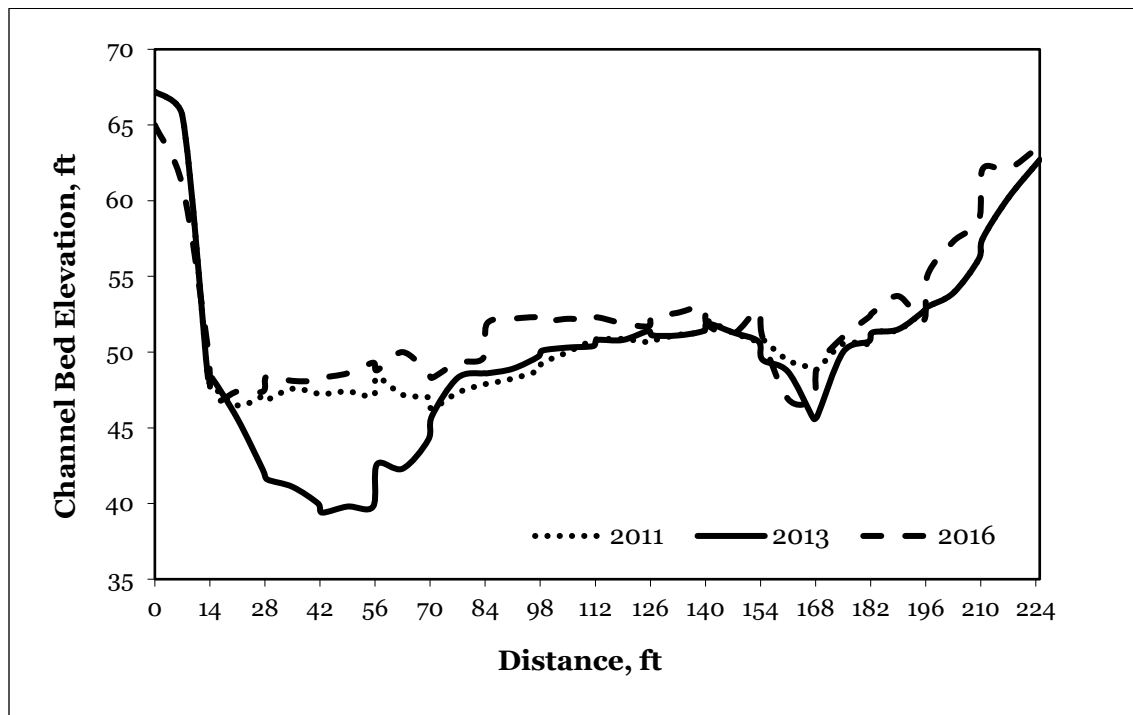
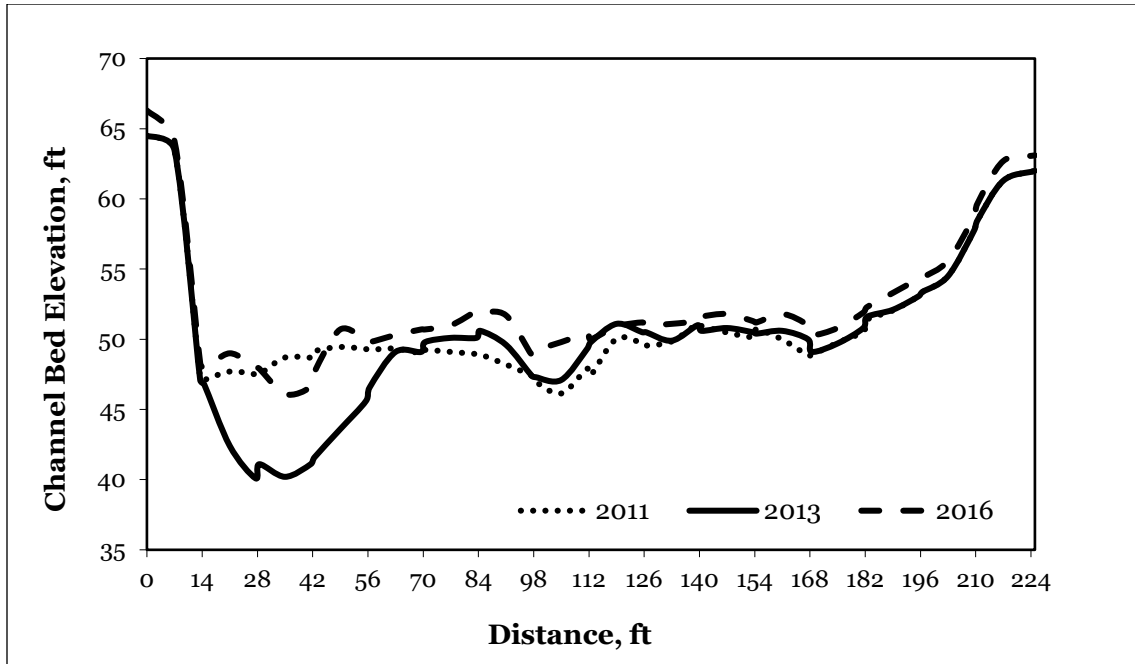

Figure 4. Channel profile for the downstream section of the bridge crossing.



5 Level II: Quantitative Assessment

The purpose of the study was to evaluate the scour potential of the existing bridge at Fort Stewart, GA. As discussed in the previous chapter, Bridge BRG15 has been identified as unstable according to the stream stability and observed scour conditions. In order to assess the scour condition, it was necessary to conceptualize the system and translate it into a numerical model. Bridge scour is a composite natural process that involves hydrologic, river hydraulics, geomorphology, and the geometry of the structures. The current method employed to calculate the scour depths is that provided by the *Hydraulic Engineering Circular No.18* (HEC-18) (Arneson et al. 2012). In order to implement this method, it was necessary to perform a hydrologic analysis based on rainfall events at the bridge location, a hydraulics assessment based on the flood flow, and laboratory testing of soil properties.

5.1 Estimation of flood magnitude

The U.S. Geological Survey (USGS) manages a wide network of flow gauges located at many streams around the nation. In the study area, the closest USGS gauge station with historical and recent flow data is located 11 miles upstream from the bridge site. However, the bridge does not have a gauge installed on it and is considered an ungauged site. Consequently, the historical flow data necessary to perform a flood frequency analysis is unavailable.

The flood discharge for the stream that passes under the bridge was estimated by using regional flood-frequency equations developed by the USGS for ungauged watersheds in Georgia. A detailed description of the regression analysis used to develop the equations for computing the flood magnitude is provided by Gotvald et al. 2009. The peak flows for 100-year (Q_{100}) and 500-year (Q_{500}) flood events were selected as the model scenarios, and the magnitudes were determined using the following regression model,

$$Q_p = a_0(DA)^{b_0} \quad (6)$$

where:

- Q_p = magnitude of the flood, in ft³/s,
- DA = drainage area of the bridge, in mi²,
- a_0 = regression coefficients and
- b_0 = regression coefficient.

In the study, Georgia was divided into five hydrologic regions. The regression coefficients are a function of the hydrologic area and the annual exceedance probability. The Bridge BRG15 site is located in hydrologic region 4. The computed flood frequency for the 100-year and 500-year events on Bridge BRG15 at Fort Stewart are presented in Table 1.

Table 1 . Year recurrence with corresponding peak flows estimates.

Annual Exceedance Probability	Recurrence Interval	Peak Flow (cfs)	a_0	b_0
0.01	100-year	22,032	380	0.594
0.002	500-year	25,046	550	0.583

5.2 Bed and bank material evaluation

Available data of the streambed material size are critical to perform an accurate estimate of the scour depths. The grain size of the soil was determined by a sieve analysis to samples collected from the riverbanks and bed. The samples were extracted at a depth of approximately 2 ft. The analysis was performed according to the standard test ASTM D-421 (2007). The sieves that were used, listed in descending size of opening, are 4, 10, 20, 60, 100, and 200. Figure 5 shows the particle-size distribution of the samples at the study site.

Figure 5. Grain-size distribution of the Canoochee River soil at the bridge site.

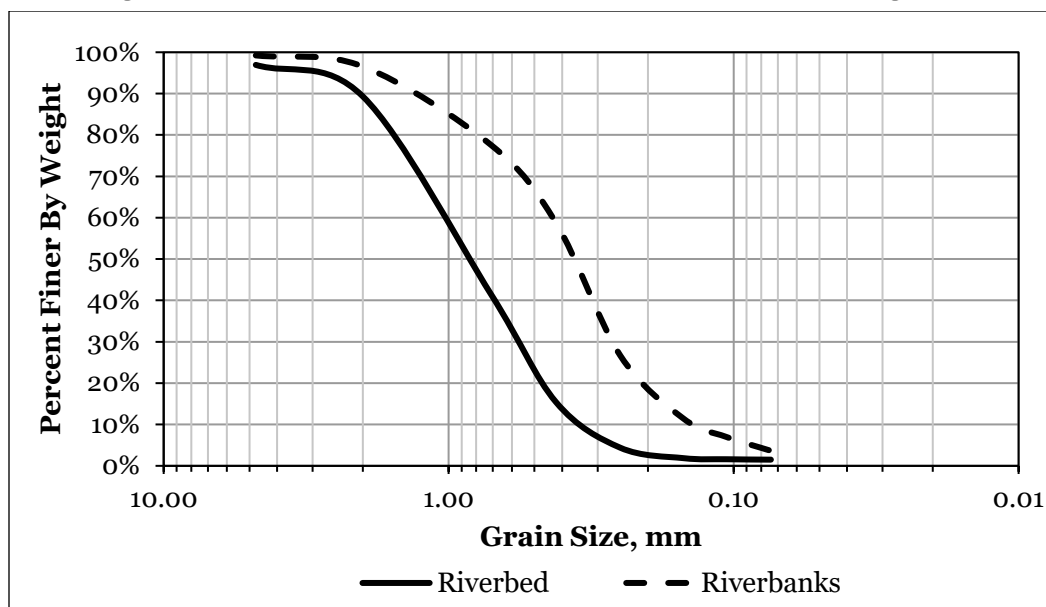

At the bridge site, the soil samples taken for the bank and the bed yielded different median diameter (D_{50}) values. The riverbed soil classified as a coarse sand with an average sediment size of 0.85 mm, whereas the bank soil resulted in a medium sand with a mean particle size of 0.38 mm. These soil properties were used as an input data for the scour computation.

5.3 One-dimensional hydraulic model

The one-dimensional computer program from the Hydrologic Engineering Center-River Analysis System (HEC-RAS; USACE 2016) was used for bridge and river modeling in order to estimate the hydraulic characteristics of the flood flows. This program is broadly used to perform a steady state condition analysis at the bridge crossing. The model was implemented to simulate flow of water-surface profiles and obtain velocity distribution through the bridge opening. Furthermore, the return period discharges that result in overtopping were determined with the hydraulic program.

The modeled reach extended approximately 8 miles, which was divided into two reaches: upstream and downstream from the bridge, each with a length of 4 miles. For the hydraulic modeling, HEC-RAS information of the physical system was used. This included the river geometry and the hydraulic structure data. The information was provided using the HEC-GeoRAS tool in the Arcmap interface that provided several utilities and

tools useful to manage the necessary input data. In order to process the channel morphology and the geospatial data in Arcmap, a digital terrain model (DTM) of the river in the triangulated irregular network (TIN) format was created using a digital elevation model (DEM). A HEC-RAS import file containing the physical properties of the system was created by digitalizing the flow paths, bank lines, cross sections and the bridge by using a satellite image of the site as a spatial reference. The import file includes the river reach and stations, stream center line, channel banks, cross sections' cut lines and elevation data, reach lengths, land uses for roughness coefficients, and hydraulic structure data for Bridge BRG15.

The Manning's roughness coefficient (n) values were assigned based on the land cover discussed in section 4.1. In this study, the n value for the channel and flood plain was computed following the procedure described by Arcement and Schneider (1989). The equation of the coefficients' value considered the effect of the vegetation, obstructions, and channel materials, among others. Therefore, the roughness coefficient was estimated using the following equation,

$$n = (n_b + n_1 + n_2 + n_3 + n_4)m \quad (7)$$

where:

- n_b = base value of n ,
- n_1 = correction factor for surface irregularities,
- n_2 = value for variation in shape and size of cross sections,
- n_3 = correction for obstructions,
- n_4 = correction for vegetation and flow conditions, and
- m = correction for meandering of the channel.

The steady-state flows for the 100-year and 500-year flood events were used as the model scenarios to simulate the water-surface profiles and velocity distributions at each cross section. These flows were specified as the upstream boundary conditions. For the downstream boundary condition, the channel slope was used. At each cross section, the program estimates the average velocity, water-surface elevation, wetted perimeter, and area. This information was used to estimate the scour depth at the bridge opening.

The hydraulic characteristics at the upstream and downstream cross sections from the bridge are summarized for the two model scenarios in Table 2. The water-surface elevations simulated for the 100-year and 500-year return period flood were greater than the average bridge deck elevation of 67 ft. This behavior is shown in Figure 6, in which for report purposes the distance is established from left to right looking downstream. For the Q_{100} , the water elevation will be approximately 2.5 ft over the road. The Q_{500} discharge presents the most critical case, since the water will cover approximately 5 ft above the bridge roadway. Consequently, these results indicate that the Bridge BRG15 roadway will have overtopped after the two flooding events.

Table 2. Summary of the one-dimensional hydraulic characteristics results.

Recurrence Interval	Model Flood Flow (cfs)	Upstream		Downstream	
		Water Surface Elevation (ft)	Average Velocity (ft/s)	Water Surface Elevation (ft)	Average Velocity (ft/s)
100-year	22,032	69.52	5.15	68.84	5.54
500-year	25,046	72.24	4.71	71.96	4.88

Figure 6. Water-surface profile from (a) upstream cross section and (b) downstream cross section.

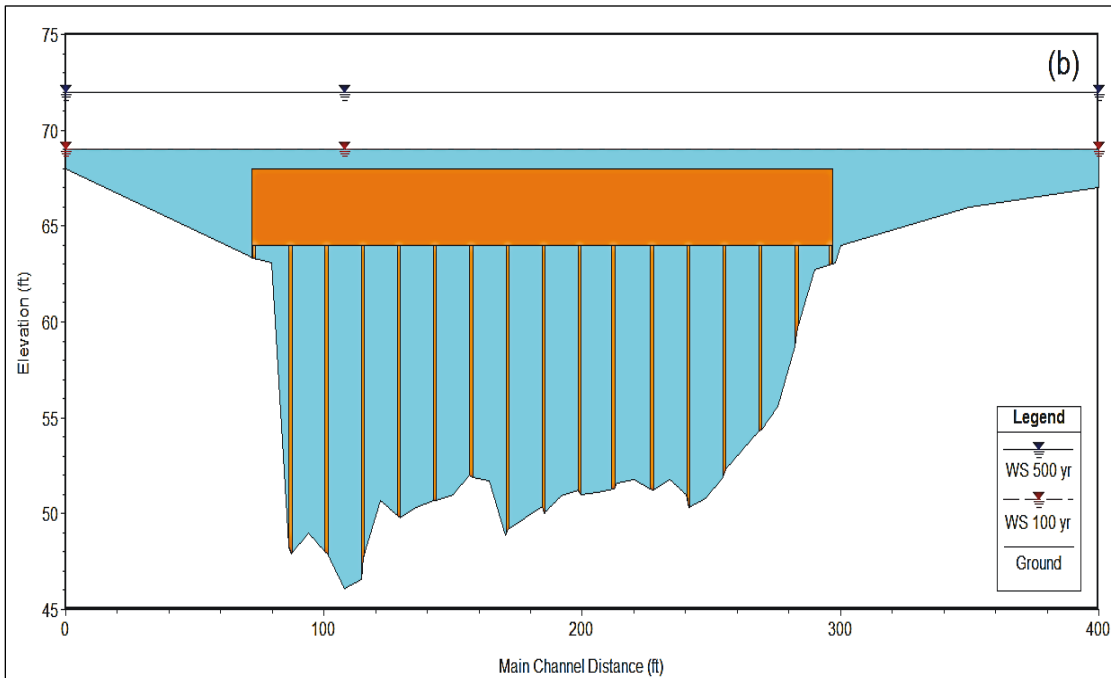
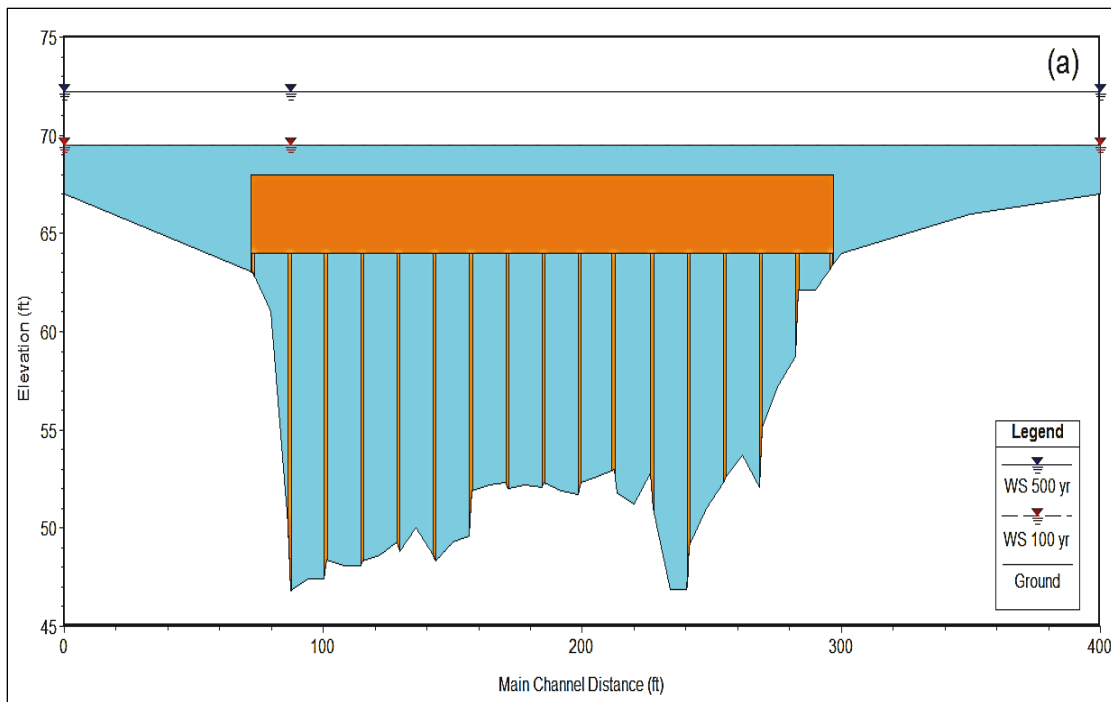

5.4 Scour assessment

The results of the hydraulic assessment, in which water depths and flow velocity were estimated, of Bridge BRG15 over the Canoochee River were used to evaluate the potential scour condition of the bridge. For this analysis, two principal components of the scour depth were determined using the HEC-18 method: contraction scour and local scour. The contraction scour represents a reduction in the elevation of the channel bed across the bridge opening, and the local scour is the removal of bed material surrounding the bridge's structure, such as pier columns and abutment walls. The procedure of the evaluation of bridges for scour is fully detailed in the fifth edition of the *Hydraulic Engineering Circular No. 18* (Arneson et al. 2012).

The computed scour depths are based on the field data and evaluations mentioned in the previous sections. Contraction scour is divided into two different types: live-bed and clear-water scour. At the bridge site, the average approach velocity was greater than the critical velocity for both model scenarios. Consequently, the contraction scour was considered to be live bed. The characteristics of the left and right abutments of the bridge were dissimilar. An absence of soil in the left abutment (looking downstream) was observed during a field inspection conducted in 2016. Thus, the abutment wall was completely exposed to the flow passing through the bridge. Hence, rather than determine the local scour for both abutments, this scour component was computed for only the right abutment in the downstream direction.

Pier scour estimates using the HEC-18 equation are based on the Colorado State University (CSU) equation. For the determination of this parameter, the following components were considered: the angle of flow upstream from the pier, pier shape and width in the direction of flow, and the configuration of the piers. At each bent the bridge had multiple-column piers. To account for this effect, a composite pier width was used for the scour prediction.

The contraction and abutment scour computed at the bridge crossing are presented in Table 3. The 500-year discharge resulted as the worst-case scenario for scour. The soil type, the angle of attack, and the bridge obstruction were the principal factors contributing to the total scour depth. At the bridge site, the soil was classified as sand, which is a very unstable and cohesionless material. Consequently, the stream bed will constantly experience changes in elevation due to the erodibility of the soil.

Table 3. Contraction and abutment scour computations for Bridge BRG15 at Fort Stewart, GA.

Recurrence Interval	Contraction Scour (ft)			Abutment Scour (ft)
	Left Channel Bank	Channel Bed	Right Channel Bank	Right
100-year	6.72	2.65	5.16	2.17
500-year	8.21	3.42	6.15	4.22

Pier scour computations using the hydraulic characteristics for the model scenarios are provided in Table 4. The pier scour results are based on each bent since, as explained before, the bridge is compounded of multiple-column piers. The most critical section of the pier scour is between bents No. 2 and No.7. This behavior is the result of the direction in which the water approaches the bridge. The streambed elevation after the flood event at each pier located on the bents was determined by subtracting the multiple columns' scour depth from the actual pier elevation.

Table 4. Pier scour depth estimate for Bridge BRG15 at Fort Stewart, GA.

Bent Number	Scour Depth (ft)	
	100-yr Flood Flow	500-yr Flood Flow
1	2.29	6.60
2	9.11	11.31
3	10.29	12.75
4	10.27	12.74
5	10.06	12.50
6	10.15	12.60
7	7.05	10.34
8	6.88	10.17
9	6.88	10.16
10	6.90	10.18
11	6.76	9.99
12	6.69	9.86
13	9.98	12.36
14	6.76	10.00
15	6.19	9.21
16	5.22	7.99
17	2.47	5.44

6 Conclusion and Recommendations

A Level II scour assessment was performed on Bridge BRG15 at Fort Stewart, GA. According to a Level I Scour Field evaluation, this bridge was identified with a high degree of susceptibility to suffer scour since significant changes in the streambed elevation have been observed from historical data. The scour depths were computed by using HEC-18, recommended by the Federal Highway Administration (FHWA), since this is the current method implemented by the United States Army Corps of Engineers. Two principal components of scour depth were estimated: contraction and local scour. The results of this study revealed the critical scour condition of Bridge BRG15. Noteworthy changes in elevations were produced by the discharges of the 100-, and 500-year return period floods, which are attributed to the high velocities produced, since both result in overtopping. Overall, the HEC-RAS hydraulic model is a very useful tool that can distribute flow across the bridge opening and provide water-surface profiles considering the effects of obstructions.

Based on the results obtained from the simulation, it is prudent to suggest many actions in order to achieve a more realistic condition of the system. Some of the most relevant recommendations include the following:

- Due to the complex nature of scour, hydrologic, topographic, and geomorphology data at the bridge site are needed to accurately estimate the hydraulic conditions. Hence, we recommend obtaining more exact scour depth results.
- Water-surface elevations, discharges, velocity magnitudes, and distribution need to be collected immediately after high-flow events in order to select the most suitable model that can be accomplished at the bridge site. Furthermore, a two-dimensional simulation should be considered for a more accurate computation of the scour depths.
- Periodic scour inspections should be performed in high-flow seasons, since scour holes generally fill in during the flood falling stage.
- Further efforts should be made to evaluate the in-situ conditions and develop an adequate Plan of Action (POA) for the scour-critical bridge. The POA should include scour inspections programmed after flood events, the installation of fixed scour monitoring devices at the bridge structures, and armoring countermeasures, such as riprap, to protect the foundation of the bridge.

References

- American Society of Testing and Materials. 2007. *Dry preparation of soil samples for particle-size analysis and determination of soil constants*. Standard D421-85, 1935. West Conshohocken, PA: ASTM International. DOI: 10.1520/Do421-85R07, www.astm.org.
- Arcement, G. J., and V. R., Schneider. 1989. Guide for selecting Manning's roughness coefficients for natural channels and flood plains. Springfield, VA: U.S. Geological Survey .
- Arneson, L. A., L. W. Zevenbergen, P. F. Lagasse, and P. E. Clopper. 2012. *Evaluating scour at bridges. 5th ed.* U.S. Federal Highway Administration Publication FHWA-HIF-12-003 Hydraulic Engineering Circular No.18. Washington, DC: Federal Highway Administration.
- Carpenter, Donald D., and Carol Miller. 2011. *A critical evaluation of bridge scour for Michigan specific conditions*. Lansing, MI: Michigan Department of Transportation.
- Federal Highway Administration (FHWA). 1991. *Evaluating scour at bridges*. Technical Advisory 5140.23. Washington, DC: U.S. Department of Transportation.
- Gotvald, Anthony J., Toby D. Feaster, and Curtis J. Weaver. 2009. *Magnitude and frequency of rural floods in the Southeastern United States, 2006: Volume 1, Georgia*. Reston, VA: U.S. Geological Survey.
- Holnbeck, S.R., and C. Parrett. 1997. Method for rapid estimation of scour at highway bridges based on limited site data. Bozeman, MT: U.S. Geological Survey.
- Homer, C.G., J. A. Dewitz, L. Yang, S. Jin, P. Danielson, G. Xian, J. Coulston, N. D. Herold, J. D. Wickham, and K. Megown. 2015. Completion of the 2011 national land cover database for the conterminous United States-representing a decade of land cover change information. *Photogrammetric Engineering and Remote Sensing* 81(5):345-354.
- Lagasse, P. F., L. W. Zevenbergen, W. J. Spitz, and L. A. Arneson. 2012. *Stream stability at highway structures. 4th ed.* U.S. Federal Highway Administration Publication FHWA-HIF-12-004 Hydraulic Engineering Circular No. 20. Washington, DC: Federal Highway Administration.
- Mueller, D. S., and C. R Wagner. 2002. *Analysis of pier scour predictions and real-time field measurements*. First International Conference on Scour of Foundations. College Station, TX: Texas Transportation Inst.
- Mueller, D. S., R. L. Miller, and W. T. John. 1994. Historical and potential scour around bridge piers and abutments of selected stream crossings in Indiana. Indianapolis, IN: U.S. Geological Survey.
- National Oceanic and Atmospheric Administration (NOAA). 2008. Average annual precipitation Georgia. www.srh.noaa.gov.

- Richardson, E. V., and S. R. Davis. 2001. *Evaluating scour at bridges. 4th ed.* U.S. Federal Highway Administration Publication NHI-01-001 Hydraulic Engineering Circular No. 18. Washington, DC: Federal Highway Administration.
- Richardson, E. V., and P. F. Lagasse. 1999. *Stream stability and scour at highway bridges.* Reston, VA: American Society of Civil Engineers.
- Suazo, Deborah, Walter Silva, and Jorge Rivera. 2013. *Methodology for scour evaluation of U.S. Army installation bridges.* ERDC TR-13-1, Vicksburg, MS: U.S. Army Engineer Research and Development Center.
- United States Army Corps of Engineers (USACE). 2016. *Hydrologic engineering center-river analysis system.* CPD-69. Davis, CA: U.S. Army Corps of Engineers Hydrologic Engineering Center (HEC).

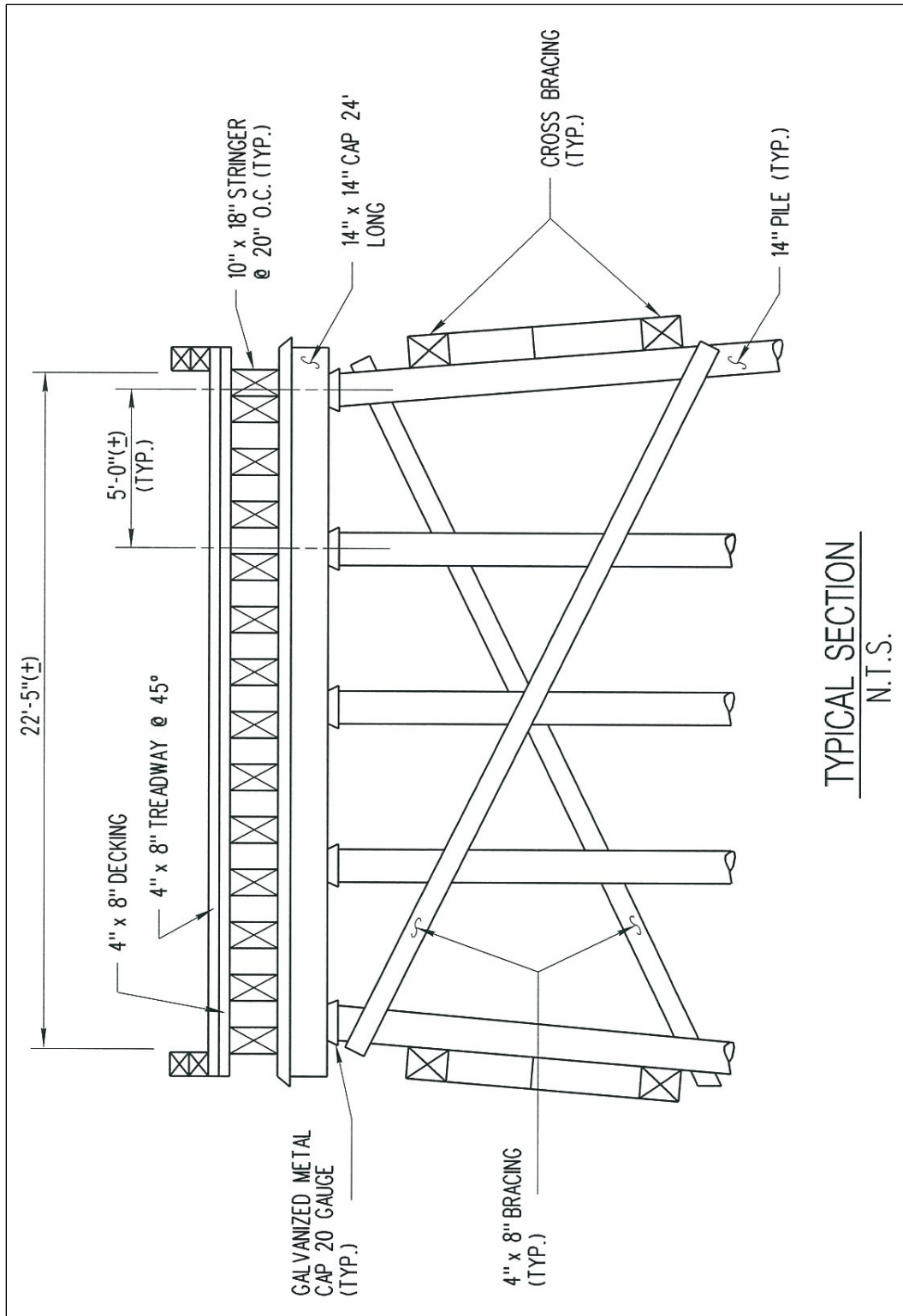

REPORT DOCUMENTATION PAGE

Form Approved
OMB No. 0704-0188

Public reporting burden for this collection of information is estimated to average 1 hour per response, including the time for reviewing instructions, searching existing data sources, gathering and maintaining the data needed, and completing and reviewing this collection of information. Send comments regarding this burden estimate or any other aspect of this collection of information, including suggestions for reducing this burden to Department of Defense, Washington Headquarters Services, Directorate for Information Operations and Reports (0704-0188), 1215 Jefferson Davis Highway, Suite 1204, Arlington, VA 22202-4302. Respondents should be aware that notwithstanding any other provision of law, no person shall be subject to any penalty for failing to comply with a collection of information if it does not display a currently valid OMB control number. **PLEASE DO NOT RETURN YOUR FORM TO THE ABOVE ADDRESS.**

1. REPORT DATE (DD-MM-YYYY) March 2019	2. REPORT TYPE Final	3. DATES COVERED (From - To)
--	--------------------------------	-------------------------------------

4. TITLE AND SUBTITLE Scour Level II Assessment of US Army Installation Bridge Facility Number: BRG15 Fort Stewart, Georgia	5a. CONTRACT NUMBER
	5b. GRANT NUMBER
	5c. PROGRAM ELEMENT NUMBER

6. AUTHOR(S) Sheila M. Arias-Román and Deborah Suazo-Dávila	5d. PROJECT NUMBER 154349
	5e. TASK NUMBER
	5f. WORK UNIT NUMBER

7. PERFORMING ORGANIZATION NAME(S) AND ADDRESS(ES) Geotechnical and Structures Laboratory U.S. Army Engineer Research and Development Center 3909 Halls Ferry Road Vicksburg, MS 39180-6199	8. PERFORMING ORGANIZATION REPORT NUMBER ERDC/GSL TR-19-5
--	---

9. SPONSORING / MONITORING AGENCY NAME(S) AND ADDRESS(ES) Headquarters Installation Management Command 2405 Gun Shed Road Fort Sam Houston, TX 78234-1223	10. SPONSOR/MONITOR'S ACRONYM(S) IMCOM
	11. SPONSOR/MONITOR'S REPORT NUMBER(S)

12. DISTRIBUTION / AVAILABILITY STATEMENT
Approved for public release; distribution is unlimited.

13. SUPPLEMENTARY NOTES

14. ABSTRACT
The most common cause of bridge failure is flood scouring of the streambed material from around the structure's foundations. Several researchers have suggested that the leading cause of bridge collapse is scour. This is the engineering term used to describe the natural process that involves the removal of sediment from around the bridge's structure, such as abutment walls and pier columns, and from the bottom and sides of the streambed due to the flow of water. The aim of this project is to develop analytical calculations by using acquired data to determine scour depth for 100-year and 500-year events or overtopping floods. The current method implemented to predict the scour depth for U.S. Army bridges is based on the general guidelines within the Hydraulic Engineering Circulars (HECs) No.18 and No.20 recommended by the Federal Highway Administration (FHWA). Bridge scour is a combination of natural processes that involves hydrology, river hydraulics, geo-morphology, and the geometry of the structures. Hence, in order to implement the current procedure, it was necessary to perform reviews of historical field channel profiles, hydrologic analysis based on rainfall events at the bridge location, hydraulics assessment based on the flood flow, and laboratory testing of soil properties. Water-surface profiles and the components of scour depths -- such as total scour, contraction scour, and pier and abutment scour -- were determined for the bridge.

15. SUBJECT TERMS Bridge Scour Bridge Failure Scour (hydraulic engineering)	Sediment Transport Scouring Pier Scour Bridges – military bases	Abutment Scour Contraction Scour Scour at bridges Fort Stewart (GA.)
---	--	---

16. SECURITY CLASSIFICATION OF:			17. LIMITATION OF ABSTRACT	18. NUMBER OF PAGES 35	19a. NAME OF RESPONSIBLE PERSON
a. REPORT Unclassified	b. ABSTRACT Unclassified	c. THIS PAGE Unclassified			19b. TELEPHONE NUMBER (include area code)