



NAVAL POSTGRADUATE SCHOOL

MONTEREY, CALIFORNIA

THESIS

**INTEGRATION OF REGENERATIVE BRAKING SYSTEMS
INTO DOD TACTICAL VEHICLES, AND THEIR POTENTIAL
TO PROVIDE A SHORT-TERM POWER SOURCE**

by

Dianna Zempel and Tyrone A. Barrion

December 2018

Thesis Advisor:
Co-Advisor:

Nicholas Dew
Gurminder Singh

Approved for public release. Distribution is unlimited.

THIS PAGE INTENTIONALLY LEFT BLANK

REPORT DOCUMENTATION PAGE			<i>Form Approved OMB No. 0704-0188</i>	
Public reporting burden for this collection of information is estimated to average 1 hour per response, including the time for reviewing instruction, searching existing data sources, gathering and maintaining the data needed, and completing and reviewing the collection of information. Send comments regarding this burden estimate or any other aspect of this collection of information, including suggestions for reducing this burden, to Washington headquarters Services, Directorate for Information Operations and Reports, 1215 Jefferson Davis Highway, Suite 1204, Arlington, VA 22202-4302, and to the Office of Management and Budget, Paperwork Reduction Project (0704-0188) Washington, DC 20503.				
1. AGENCY USE ONLY (Leave blank)		2. REPORT DATE December 2018	3. REPORT TYPE AND DATES COVERED Master's thesis	
4. TITLE AND SUBTITLE INTEGRATION OF REGENERATIVE BRAKING SYSTEMS INTO DOD TACTICAL VEHICLES, AND THEIR POTENTIAL TO PROVIDE A SHORT-TERM POWER SOURCE			5. FUNDING NUMBERS	
6. AUTHOR(S) Dianna Zempel and Tyrone A. Barrion				
7. PERFORMING ORGANIZATION NAME(S) AND ADDRESS(ES) Naval Postgraduate School Monterey, CA 93943-5000			8. PERFORMING ORGANIZATION REPORT NUMBER	
9. SPONSORING / MONITORING AGENCY NAME(S) AND ADDRESS(ES) N/A			10. SPONSORING / MONITORING AGENCY REPORT NUMBER	
11. SUPPLEMENTARY NOTES The views expressed in this thesis are those of the author and do not reflect the official policy or position of the Department of Defense or the U.S. Government.				
12a. DISTRIBUTION / AVAILABILITY STATEMENT Approved for public release. Distribution is unlimited.			12b. DISTRIBUTION CODE A	
13. ABSTRACT (maximum 200 words) This paper analyzes the introduction of regenerative braking systems into DoD tactical vehicles, with a focus on Marine Corps logistics vehicles. The analysis addresses a regenerative braking system's ability to provide a short-term energy source for ancillary systems as well as assisting in the vehicle's propulsion to save fuel. Different means of incorporating regenerative braking systems are evaluated to determine the most efficient and effective alternatives (e.g., regenerative braking integrated into the drive-train and in-wheel regenerative braking systems). Other means of improving fuel efficiency and powering on-board systems are also evaluated, to include idle-reduction technology, improved batteries, and addition of solar panels. Each system is assessed for its potential to provide power for other on-board systems, such as C2 assets, as well as fuel savings. The potential payback period is assessed using cost-benefit analysis. Research on regenerative braking systems is reviewed as well as issues driving the integration of energy-saving systems and factors affecting the acquisition and integration of these technologies. This study helps decision-makers to make informed decisions about the potential use of regenerative braking systems in tactical logistics vehicles. While regenerative braking systems do provide an alternate power source of auxiliary power systems, they were found to not be a viable alternative at this point. Idle-reduction systems should be pursued.				
14. SUBJECT TERMS regenerative braking, hybrid vehicles, logistic vehicles, energy fuel			15. NUMBER OF PAGES 133	
			16. PRICE CODE	
17. SECURITY CLASSIFICATION OF REPORT Unclassified	18. SECURITY CLASSIFICATION OF THIS PAGE Unclassified	19. SECURITY CLASSIFICATION OF ABSTRACT Unclassified	20. LIMITATION OF ABSTRACT UU	

THIS PAGE INTENTIONALLY LEFT BLANK

Approved for public release. Distribution is unlimited.

**INTEGRATION OF REGENERATIVE BRAKING SYSTEMS INTO DOD
TACTICAL VEHICLES, AND THEIR POTENTIAL TO PROVIDE A
SHORT-TERM POWER SOURCE**

Dianna Zempel
Major, United States Marine Corps
BS, U.S. Naval Academy, 2008

Tyrone A. Barrion
Major, United States Marine Corps
BS, U.S. Merchant Marine Academy, 2006

Submitted in partial fulfillment of the
requirements for the degree of

MASTER OF SCIENCE IN MANAGEMENT

from the

**NAVAL POSTGRADUATE SCHOOL
December 2018**

Approved by: Nicholas Dew
Advisor

Gurminder Singh
Co-Advisor

Chad W. Seagren
Academic Associate, Graduate School of Business and Public Policy

THIS PAGE INTENTIONALLY LEFT BLANK

ABSTRACT

This paper analyzes the introduction of regenerative braking systems into DoD tactical vehicles, with a focus on Marine Corps logistics vehicles. The analysis addresses a regenerative braking system's ability to provide a short-term energy source for ancillary systems as well as assisting in the vehicle's propulsion to save fuel. Different means of incorporating regenerative braking systems are evaluated to determine the most efficient and effective alternatives (e.g., regenerative braking integrated into the drive-train and in-wheel regenerative braking systems). Other means of improving fuel efficiency and powering on-board systems are also evaluated, to include idle-reduction technology, improved batteries, and addition of solar panels. Each system is assessed for its potential to provide power for other on-board systems, such as C2 assets, as well as fuel savings. The potential payback period is assessed using cost-benefit analysis. Research on regenerative braking systems is reviewed as well as issues driving the integration of energy-saving systems and factors affecting the acquisition and integration of these technologies. This study helps decision-makers to make informed decisions about the potential use of regenerative braking systems in tactical logistics vehicles. While regenerative braking systems do provide an alternate power source of auxiliary power systems, they were found to not be a viable alternative at this point. Idle-reduction systems should be pursued.

THIS PAGE INTENTIONALLY LEFT BLANK

TABLE OF CONTENTS

I.	INTRODUCTION.....	1
A.	BACKGROUND	1
B.	OBJECTIVE OF THIS STUDY	2
C.	RESEARCH QUESTIONS	3
D.	SCOPE OF STUDY	3
E.	ORGANIZATION OF STUDY	4
II.	LITERATURE REVIEW	5
A.	ENERGY RECOVERY SYSTEMS.....	5
	1. Solar Power Application.....	6
B.	OVERVIEW OF REGENERATIVE BRAKING.....	6
	1. Current Uses.....	7
	2. Feasibility of Retrofitting	8
	3. Challenges of Retrofitting	10
C.	CURRENT PLATFORMS / HYBRID VEHICLES.....	11
	1. Toyota Prius	12
	2. Chevrolet Volt	13
	3. Tesla	14
D.	ENERGY STORAGE SYSTEMS (BATTERIES).....	14
	1. Characteristics.....	15
	2. Lead Acid.....	16
	3. Nickel Metal-Hydride (Ni-MH)	17
	4. Lithium Ion (Li-ion) Batteries	18
	5. Capacitors.....	20
E.	BATTERY MANAGEMENT SYSTEMS	21
F.	FULLY BURDENED COST OF FUEL (FBCF)	23
	1. Sourcing Fuel in an Austere Environment	25
	2. Powering Auxiliary Systems	27
	3. Idle-Reduction Considerations	28
G.	USMC [LOGISTIC] TACTICAL VEHICLES.....	30
	1. Medium Tactical Vehicle Replacement	31
	2. Logistic Vehicle System Replacement.....	32
	3. Future Generation Tactical Vehicles—The Joint Light Tactical Vehicle (JLTV)	33
H.	THE DOD ACQUISITION SYSTEM	34
	1. Depot-Level Maintenance	39

III.	METHODOLOGY AND RESEARCH APPROACH.....	43
A.	INTRODUCTION.....	43
B.	FOUNDATIONAL INFORMATION AND ASSUMPTIONS	43
1.	Environmental Protection Agency (EPA) Driving Schedule	43
2.	General Mathematical Constants, Conversions, and Formulas	44
3.	Basic Vehicle Operation	47
4.	Fuel Cost and Consumption while Idling	47
5.	Cost of Labor.....	49
6.	Solar Irradiance	52
C.	GENERAL MTVR AND LVSR CONSIDERATIONS.....	53
1.	Alternator Types and Efficiencies for the MTVR and LVSR.....	53
2.	Energy Demand of Auxiliary Systems	53
3.	Service Life Expectancy of the MTVR and LVSR	54
D.	OVERVIEW OF UPGRADE OPTIONS	54
1.	Upgrade 1—Anti-Idling Device, Supercapacitor, and Emergency Override.....	55
2.	Upgrade 2—Drivetrain Regenerative Braking System with an Auxiliary Power Unit (APU)	56
3.	Upgrade 3—In-wheel Regenerative Braking System with an Auxiliary Power Unit (APU).....	57
4.	Upgrade 4—Improved Starter Batteries	59
5.	Upgrade 5—Flexible Solar Array.....	60
IV.	DATA ANALYSIS	61
A.	INTRODUCTION.....	61
1.	Break-Even Point	61
2.	Yearly Savings and Net Present Value.....	61
B.	UPGRADE 1: ANTI-IDLING DEVICE, SUPERCAPACITOR, EMERGENCY OVERRIDE.....	62
C.	UPGRADE 2: DRIVETRAIN REGENERATIVE BRAKING SYSTEM WITH AUXILIARY POWER UNIT.....	64
D.	UPGRADE 3: IN-WHEEL REGENERATIVE BRAKING SYSTEM WITH AUXILIARY POWER UNIT.....	66
E.	UPGRADE 4: IMPROVED STARTED BATTERIES	70
F.	UPGRADE 5: FLEXIBLE SOLAR ARRAY	71
V.	COST—BENEFIT ANALYSIS.....	75
A.	COMPARISON CRITERIA.....	75

B.	CALCULATIONS	76
1.	Y-Axis.....	76
2.	X-Axis.....	77
C.	RESULTS	77
D.	SENSITIVITY ANALYSIS.....	82
VI.	CONCLUSIONS AND RECOMMENDATIONS.....	85
A.	CONCLUSIONS	85
B.	RECOMMENDATIONS.....	86
	APPENDIX A. EXCEL SPREADSHEET	89
	APPENDIX B. BATTERY SPECIFICATIONS	95
	LIST OF REFERENCES	97
	INITIAL DISTRIBUTION LIST	107

THIS PAGE INTENTIONALLY LEFT BLANK

LIST OF FIGURES

Figure 1.	Basic powertrain configuration of a series hybrid vehicle. Source: “Chevrolet Volt” (n.d.).	12
Figure 2.	Adoption rates of different fuel improvement technologies in the commercial trucking industry. Source: NACFE (2014).	29
Figure 3.	DoD Acquisition System—Levels of Readiness. Source: Office of the Secretary of Defense [OSD] Manufacturing Technology Program (2015).	38
Figure 4.	View of back of LVSR stripped at MCLB Barstow with cables ready for installation	41
Figure 5.	Alternative view of back of stripped LVSR at MCLB Barstow	41
Figure 6.	Completely stripped shells of Amphibious Assault Vehicles (AAV)	42
Figure 7.	Analysis driving schedule. Source: Environmental Protection Agency [EPA] (2018).	44
Figure 8.	View of MTVR wheel axle	50
Figure 9.	View of MTVR wheel axle and suspension	50
Figure 10.	Side view of MTVR rear wheel axle and strut	51
Figure 11.	View of Cougar axles mounted to V-shaped hull	51
Figure 12.	Close-up view of Cougar wheel axle	52
Figure 13.	Visual of drop-in capacitor battery from Maxwell. Source: Amazon.com (2018).	56
Figure 14.	Allison regenerative drivetrain transmission. Source: Allison Transmission (2016).	57
Figure 15.	Regenerative braking system applied to vehicle wheel. Source: Kane (2018).	58
Figure 16.	Flexible solar array applied to roof of commercial truck	60
Figure 17.	Graphical representation of cost-benefit analysis	76
Figure 18.	Cost-benefit analysis for the MTVR	78

Figure 19.	Cost-benefit analysis for the LVSR	79
Figure 20.	Sensitivity analysis results (per year)	83
Figure 21.	Master MTRV spreadsheet snapshot: Energy generated from driving schedule.....	90
Figure 22.	Master MTRV spreadsheet snapshot: Upgrade energy calculations	91
Figure 24.	Master LVSR spreadsheet snapshot: Energy generated from driving schedule.....	92
Figure 25.	Master LVSR spreadsheet snapshot: Upgrade energy calculations.....	93

LIST OF TABLES

Table 1.	Summary of Battery Characteristics. Adapted from Crase and Sims (2017).....	22
Table 2.	Elements and Definitions of the Fully Burdened Cost of Energy. Adapted from Bohnwagner (2013).	24
Table 3.	LVSR Specifications. Adapted from “Oshkosh Logistic Vehicle System Replacement (LVSR)” (n.d.).....	33
Table 4.	JLTV specifications. Adapted from “Joint Light Tactical Vehicle” (n.d.).....	34
Table 5.	Formulas used to determine maximum potential energy generated	46
Table 6.	MTRV parameters utilized for calculations.....	48
Table 7.	LVSR Parameters utilized for calculations.....	49
Table 8.	Formulas for determining in-wheel energy capture.....	58
Table 9.	Cost break-down of Upgrade 1	62
Table 10.	Upgrade 1 returns.....	63
Table 11.	Break-down of payback period for Upgrade 1 in CONUS environment	63
Table 12.	Break-down of payback period for Upgrade 1 in OCONUS environment	63
Table 13.	Cost break-down of Upgrade 2.....	64
Table 14.	Returns to MTRV from Upgrade 2.....	65
Table 15.	Returns to LVSR from Upgrade 2	65
Table 16.	Break-down of payback period for Upgrade 2 in CONUS Environment.....	66
Table 17.	Break-down of payback period for Upgrade 2 in OCONUS Environment.....	66
Table 18.	Cost break-down of Upgrade 3.....	67

Table 19.	Returns to MTRV from Upgrade 3	68
Table 20.	Returns to LVSR from Upgrade 3	69
Table 21.	Break-down of payback for Upgrade 3 in training environment	69
Table 22.	Break-down of payback for Upgrade 3 in deployed environment.....	70
Table 23.	Cost break-down of Upgrade 4	70
Table 24.	Cost break-down of Upgrade 5	71
Table 25.	NPV worksheet for upgrade 1 in CONUS environment (MTRV & LVSR).....	73
Table 26.	NPV worksheet for upgrade 1 in OCONUS environment (MTRV & LVSR).....	74
Table 27.	Consolidated cost-benefit analysis calculations for the MTRV	80
Table 28.	Consolidated cost-benefit calculations for the LVSR.....	81
Table 29.	MTRV APU energy capture calculations	95
Table 30.	LVSR APU energy capture calculations.....	95

LIST OF ACRONYMS AND ABBREVIATIONS

AAFS	amphibious assault fuel system
AC	alternating current
ADDZEV	affordable add-on zero emission vehicle
AoA	analysis of alternatives
AO	area of operations
APU	auxiliary power unit
BMS	battery management system
C4I	command, control, communications, computers & intelligence
CDD	capabilities development document
CDR	critical design review
CJCS	Chairman of the Joint Chiefs of Staff
CLB	Combat Logistics Battalion
COC	command operations center
COTS	commercial-off-the-shelf
DAG	Defense Acquisition Guidebook
DAS	Defense Acquisition System
DC	direct current
DLA	Defense Logistics Agency
DoD	Department of Defense
DoDI	Department of Defense Instruction
DT	development testing
EAMA	European Automotive Manufacturers Association
ECP	engineer change proposal
EMD	engineering and manufacturing development
EPA	Environment Protection Agency
ESB	Engineer Support Battalion
FBCE	fully burdened cost of energy

FBCF	fully burdened cost of fuel
FOC	full operating capability
FY	fiscal year
FYDP	fiscal year defense plan
HMMWV	high mobility, multi-wheeled vehicle
HN	host nation
hp	horsepower
HRB	hydrostatic regenerative braking
ICD	initial capabilities document
ICE	internal combustion engine
IED	improvised explosive device
IOC	initial operating capability
IOT&E	initial operational test and evaluation
JCIDS	Joint Capabilities Integration and Development Systems
JLTV	Joint Light Tactical Vehicle
KERS	kinetic energy recovery system
kg	kilogram
KPP	key performance parameter
LCE	Logistics Combat Element
LHS	load handling system
Li-ion	lithium ion
LRIP	low rate initial production
LVS	logistical vehicle system
LVSR	logistics vehicle system replacement
MCLB	Marine Corps Logistics Base
MDA	Milestone Decision Authority
MDD	material development decision
MEF	Marine Expeditionary Force
mpg	miles per gallon

mph	miles per hour
MPS	maritime prepositioning ship
MRL	material readiness level
MSA	material solution analysis
MTVR	medium tactical vehicle replacement
NDS	National Defense Strategy
NDAA	National Defense Authorization Act
NET	new equipment training
Ni-MH	nickel-metal hydride
OA	operational assessment
O&S	operations and support
P&D	production and deployment
PDR	preliminary design review
PEOLSAT	Program Executive Officer land system advanced technology
rpm	revolutions per minute
SecDef	Secretary of Defense
SLI	starter, light, ignition
SOP	standard operating procedure
T&E	training and equipment
TMRR	technology maturation and risk reduction
TRL	technology readiness level
W	watt
Wh	watt-hour

THIS PAGE INTENTIONALLY LEFT BLANK

EXECUTIVE SUMMARY

In the most recent National Defense Strategy, Secretary of Defense (SecDef) James Mattis challenges the Department of Defense to “modernize in key capabilities” (p. 6) while tasking military leaders to “drive budget discipline and affordability” (p. 10). Given the large sums our nation’s military expends purchasing fuel for tactical vehicles, introducing new technologies that save fuel is an opportunity to answer the challenges posed by the SecDef. During his fielding of preliminary questions for the Armed Services Committee back in 2017, SecDef James Mattis stated that our military “faced...unacceptable limitations because of their dependence on fuel” and expressed concern over the limitations imposed by our reliance on fuel. Besides the distance our vehicles can travel, there are other operational inflexibilities our dependence on fuel presents.

This thesis addresses this issue by exploring the efficacy of regenerative braking and anti-idling systems to reduce fuel consumption and provide an alternative power source for auxiliary systems in USMC tactical vehicles (the MTRV and LVSR).

We find that regenerative braking systems could reduce fuel use by 6-13% and an anti-idling system may reduce fuel use by 24–38%, thus somewhat reducing the operational limitations imposed by fuel.

Supplying fuel and adequate power for operations is a significant planning factor in military operations. Both prior research and the authors’ personal experience confirms that the operation of tactical vehicles accounts for a significant, if not the largest, portion of fuel consumption during a mission’s execution. Auxiliary systems integrated into the vehicle also contribute to the fuel consumption rate. As the DOD pushes to modernize the force, these auxiliary systems are increasing and becoming commonplace in multiple military platforms, EG communication suite (VRC-113). Operating tactical vehicles with regenerative braking systems would provide an alternative power source to engine-driven power generation.

The cost of fuel in a tactical environment, which is predominantly austere and hostile, invariably accounts for a significant portion of expenditures and is of growing concern to Congress and the DoD. The FBCF is the cost of everything it takes to deliver fuel to the warfighter. This includes the cost to tactically deliver the fuel and the force protection required to protect it (Bohnwagner, 2013). A study conducted by the Marine Corps found that a life was lost every 24 fuel resupply convoys conducted in Afghanistan (Eady et al., 2009). Since the scenarios and elements determining the burden of a gallon of fuel in a hostile environment is always in flux and fluid, the exact cost is difficult to pinpoint, but is sometimes extremely high. As an example, the price of a gallon of fuel in Afghanistan has been quoted as being as high as \$600 (Dimotakis et al., 2006).

SOME WELL-KNOWN BARRIERS EXIST TO REDUCING FUEL USE

To power on-board electrical systems, tactical vehicles idle. The justification for idling a vehicle's engine include the need to properly prepare for convoy operations (getting into proper order, conducting pre-combat checks/inspections, etc.), the desire to maintain a comfortable ambient temperature (i.e., staying cool or warm in adverse weather conditions), and the need to maintain a sufficient charge on the battery to restart the vehicle, if necessary. In particular, there remains resistance to idle-reduction in the Marine Corps because of concerns about a vehicle's inability to start because of drained batteries (Gallenson & Salem, 2014).

However, COTS alternatives are available that solve this problem economically. A supercapacitor drop-in battery solution ensures a truck will still start in the case the batteries are inadvertently drained by powering either too many auxiliary systems, or for too long. The idle-reduction technology (with override capability) would serve as a forcing function to reducing the burden of fuel and subsequently increasing operational flexibility. The initial up-front costs of an idle-reduction package is relatively small and the payback period for such a system is short even in a training-only environment where the break-even point occurs in just over a year. Eliminating the need to idle engines for operations translates to silent watch capabilities, which can make units operating in hostile environments more lethal. The reduction in engine idle time also increases the life of the vehicle by reducing the effects of wear and tear. These benefits are additional

to the ones we have quantified in our study and add to the case for the integration of idling-reduction systems.

Our analysis revealed that while regenerative braking saves fuel in a tactical environment, these savings are not enough to make these systems financially viable based on CONUS training costs savings. Neither of the regenerative braking systems analyzed resulted in a payback period within the vehicle's expected remaining service life when analyzed for a garrison environment (i.e., "CONUS"). The payback periods for the analyzed regenerative braking systems ranged from 26 years to over 57 years. These findings applied to calculations for a payback period in a training environment only in which a gallon of gas is assumed to be \$2.76 (DLA, 2018).

Idle-reduction technology, however, is financially attractive even in a CONUS training environment. Based only on these savings, across the USMC fleet of 11,000 MTRV and 2,500 LVSR trucks, under a set of reasonable assumptions, the USMC can save \$25–137M (CY\$18) over the next 20 years by adopting idle-reduction systems that available COTS today.

References

- Bohnwagner, A. (2013). *An overview of the fully burdened cost of energy (FBCE)*. Retrieved from Office of the Under Secretary of Defense for Acquisition, Technology, and Logistics: https://www.acq.osd.mil/eie/Downloads/OE/Energy%20FBCE_12-11-13.pdf
- Defense Logistics Agency [DLA]. (2018, March 29) Memorandum for Assistant Secretary of the Army (Financial Management and Comptroller), Assistant Secretary of the Navy (Financial Management and Comptroller), Assistant Secretary of the Air Force (Financial Management and Comptroller), Deputy Chief Management Officer, Director, Defense Finance and Accounting Service, Directors, Defense Agencies, Under Secretary of Defense, Subject: Fiscal Year (FY) 2018 Fuel Price. Retrieved from <http://www.dla.mil/Energy/Business/StandardPrices/>
- Dimotakis, P., Grober, R., & Lewis, N. (2006). *Reducing DoD fossil-fuel dependence*. McLean, VA: The MITRE Corporation.

Eady, D. S., Siegel, S. B., Bell, S., Dicke, S. H. (2009). *Sustain the mission project: Casualty factors for fuel and water resupply convoys* (Report No. CTC-CR-2009-163). Arlington, Virginia: Army Environmental Policy Institute.

Gallenson, A., Salem, A. (2014). *A study of human behavior & operational energy: Analysis and recommendations for the Marine Corps to increase its operational reach*. Retrieved from https://nps.primo.exlibrisgroup.com/discovery/fulldisplay?docid=alma991005398493103791&context=L&vid=01NPS_INST:01NPS&search_scope=MyInst_and_CI&tab=Everything&lang=en

ACKNOWLEDGMENTS

First and foremost, we would like to thank God for the opportunity, fortitude, and patience to complete our curriculum at the Naval Postgraduate School. Without His steady, guiding hand we would not have been able to accomplish this feat.

The authors would also like to personally thank Professors John Gibson and Dr. Gurminder Singh, for providing the origins of this research, and the Expeditionary Energy Office (E2O), in sponsoring and supporting our research efforts. We hope we have done justice to your idea and provided relevant information toward its continued development and implementation. We would also like to thank Ms. Betty Jackson and her co-workers at MCLB Barstow, for their hospitality, professionalism, and expertise. The opportunity to witness first-hand the work completed at Yermo greatly expanded our knowledge and understanding in multiple areas; this experience will influence the remainder of our careers. We would like to thank Dr. Anthony Gannon for the immeasurable guidance in the realm of engineering and physics. Without your enthusiasm and knowledge, we would not have been able to develop the model in which we derived this analysis' results. We would also like to thank Dr. Nicholas Dew, for his constant support, guidance and direction in our research efforts, and his contribution to both our personal and professional development, extending beyond the scope of this research. His mentorship throughout the conduct of this thesis was more than we could have asked for. Our thanks also goes out to LCDR Kelsey M. Barrion, USCG-R, for her versatility, insight, and support. As a wife, mother, engineer, and military officer, she expertly balanced the home, a career, and two children under two, all while assisting us with our thesis. Her professional knowledge in the realm of mechanical and electrical engineering proved invaluable in the maturation of this research's data. We are in her debt for the completion of this thesis and retention of our sanities.

THIS PAGE INTENTIONALLY LEFT BLANK

I. INTRODUCTION

A. BACKGROUND

The United States Department of Defense has entered a new era of military spending and fiscal constraint. There is an ever-increasing level of attention paid to how funds are allocated and spent. Secretary of Defense (SecDef) James Mattis calls on service members and military leaders to “drive budget discipline and affordability” (Mattis, 2018, p. 10) in the National Defense Strategy. He also challenges the Department of Defense (DoD) to “modernize in key capabilities” (Mattis, 2018, p. 6). Given the large sums our nation’s military and DoD expend on purchasing fuel for their tactical vehicles (Boundy et al., 2017), introducing new technologies that save fuel is an opportunity to help address both the operational and financial challenges posed by the SecDef. This thesis addresses this issue by exploring the efficacy of regenerative braking and anti-idling systems to provide an alternative power source for auxiliary systems in USMC tactical vehicles.

One of the biggest planning factors in military operations is supplying fuel and adequate power for operations. From the authors’ personal experience, the operation of tactical vehicles accounts for a significant, if not the largest, portion of fuel consumption during a mission’s execution. Contributing to the consumption of fuel in tactical vehicles is the requirement to power auxiliary systems integrated into the vehicle. As the DoD pushes to modernize the force, these auxiliary systems are increasing and becoming commonplace in multiple military platforms. Their existence, and subsequent energy draw, is a secondary problem this thesis strives to address. Operating tactical vehicles with regenerative braking systems would provide an alternative power source to engine-driven power generation. Through the simple act of applying the brakes, the once-lost energy can be captured and utilized for power generation. The added flexibility from improved fuel economy would reduce the demand for fuel. While not a primary focus of this thesis, regenerative braking also creates the ability to expand operations while simultaneously reducing our footprint.

While answering questions posed by the Armed Services Committee, SecDef Mattis presented concern over the limitations imposed by our reliance on fuel. Besides the distance our vehicles can travel, there are other operational inflexibilities the tether introduces. Lower fuel use presents an opportunity to reduce this inflexibility. Implementation of regenerative braking and idle reductions both present an opportunity to save fuel. The amount of fuel saved translates into improved fuel economy, which ultimately means our vehicles can travel farther with less, thereby expanding our effective area of operations. Additionally, a reduction in need for fuel means less supply runs, which present our adversary with fewer opportunities to attack.

Other benefits of reduced idling (which is a direct result of energy recovery systems) are a lower heat and sound signature, which make units a more difficult target for the enemy. Powering of auxiliary equipment on vehicles through the energy captured via regenerative braking also provides the opportunity for silent watch operations, which can make units operating in hostile environments more lethal. Regenerative braking provides these opportunities without the addition of more trucks and personnel simply to carry additional power equipment and fuel; our forces have the potential to be more lethal while being leaner.

B. OBJECTIVE OF THIS STUDY

This study evaluates several different means of improving energy efficiency for follow-on use in powering on-board ancillary systems. The primary means evaluated are regenerative braking systems and anti-idling technology. On-board solar power will also be addressed as alternative technologies for reducing fuel consumption. Improving fuel economy is a natural by-product of the systems this thesis analyzes. It is therefore a common reference and basis of measurement.

The desired end state of this thesis is to provide decision-makers for vehicular programs of record with information regarding the feasibility and financial payback of installing these energy saving systems for the Marine Corps logistics vehicles MTRV and LVSR.

C. RESEARCH QUESTIONS

- What types of regenerative braking systems and energy saving systems exist that are capable of being retrofitted for military application?
- How technically feasible are these systems at saving fuel and powering MTVR and LVSR auxiliary systems?
- What is the financial payback of the different technical alternatives?

D. SCOPE OF STUDY

The scope of this research includes: (1) a review of the concept of regenerative braking and associated systems; (2) a review of energy storage systems; (3) how regenerative braking can be applied to tactical vehicles to supply a short-term power source; (4) methods of integrating regenerative braking systems into tactical vehicles; (5) cost-benefit analysis of different means/methods of introduction; and (6) an analysis of which system(s) would ultimately provide a return on investment through the amount of fuel the system would save. This thesis concludes with a recommendation for what type(s) of regenerative braking system(s) and/or energy saving and recovery systems should be pursued for integration into tactical vehicles. The recommendation is based on the cost of acquisition and installation and the time it takes to recoup that cost via savings in fuel (i.e., “breakeven time”). Upgrades ultimately considered for selection and recommendation are those with a realistic break-even time while still providing improved performance coupled with fuel savings.

Relatively mature systems were evaluated for possible introduction. The intent of this thesis is to provide options that are relatively advanced, with commercial-off-the-shelf (COTS) availability, and would require minimal modification, to the system and/or the vehicle in which they are installed, for full integration. In principle, this should allow for smoother navigation of the Defense Acquisition System and quicker adoption.

The financial analysis focuses primarily on the economic benefits and costs (i.e., fiscal). This thesis is not a detailed analysis of systems and engineering costs and benefits. Military suitability in regard to a system’s robustness, ability to withstand

certain forces, susceptibility to environmental conditions, etc., were not studied or analyzed.

E. ORGANIZATION OF STUDY

This thesis contains six chapters. Chapter I introduces the topic, why it is applicable, and the goal of this analysis. Chapter II provides a literary review spanning the topic of energy recovery systems and regenerative braking. It addresses current applications along with other considerations necessary to realize the benefits of regenerative braking. It also introduces topics that require an understanding for regenerative braking to be realized in a military setting and an introduction of the Marine Corps' two primary logistics vehicles (to which the analysis of regenerative braking systems is applied).

Chapter III describes the methodological approach, to include assumptions, planning factors, formulas, equations/calculations, and the type of specific systems (or "upgrades") evaluated, along with specifications utilized for calculations. Chapter IV covers the findings of each specific upgrade. Findings address the energy effectively harnessed, payback period and break-even point, and yearly savings, in addition to up-front procurement and installation costs. Chapter V continues the analysis, delving further into the cost-benefit of each upgrade and completes the financial analysis. A sensitivity analysis is also included at the end of Chapter V. Chapter VI concludes this thesis with conclusions and recommendations.

II. LITERATURE REVIEW

This chapter helps sets the stage by providing a cursory overview of energy recovery systems. A discussion of harnessing solar power for application with vehicle systems is also addressed as it plays a part in the analysis. The concept of regenerative braking itself is then covered, with insights into its history, the current technological state and application in the civilian sector. The feasibility for retrofitting vehicles with regenerative braking is briefly covered. Energy storage and management systems are also explained, as the effectiveness of a regenerative braking system is dependent upon the characteristics of these components.

The chapter then provides an overview of those topics and considerations inherent in military operations. An overview of the cost, or “burden,” of fuel is discussed, with a more detailed section on the effort required to source fuel in an austere environment.

The chapter concludes with a review of the tactical vehicles in which regenerative braking may be applied and an explanation on the Defense Acquisition System. For regenerative braking systems to be adopted for our tactical vehicles, the Defense Acquisition System must be effectively navigated.

A. ENERGY RECOVERY SYSTEMS

There are numerous types of energy recovery systems. These systems can be quite simple (and dated). Such an example is historic flour mills, that would harness the power of a nearby stream to turn the stones in the mills to grind flour. With advances in technology, humans are now able to “recover” and harness energy from not only moving water, but wind, sun, steam, and other sources. While there are numerous recovery systems, this analysis focuses primarily on *kinetic* energy recovery via regenerative braking systems. Energy harness via the sun’s arrays (i.e., solar power), is also addressed in this analysis in order to provide a comparison with this low-cost energy recovery option. Detailed data and literature on solar power is, however, beyond the purview of this thesis.

1. Solar Power Application

With recent improvements in photovoltaic materials, production, and efficiency rates, solar power is becoming a major contributor to energy production around the world. While commonly utilized to provide power in grid-like systems (i.e., homes and facilities), advances made in solar technology are making it more feasible for mobile applications. Such an application are flexible solar arrays, which can be affixed to vehicles such as motor homes and trucks, e.g., long-haul semi-tractor trailers. These arrays can be used to power the auxiliary systems in sleeper-cabs and thereby reduce the demand placed on the vehicle's alternator (Bergstrom Inc., 2018). A recent study conducted by the North American Council for Freight Efficiency (NACFE) found the application of flexible solar arrays to be a worthwhile investment, especially for semis with telematics or refrigeration units (North American Council for Freight Efficiency [NACFE], 2018).

B. OVERVIEW OF REGENERATIVE BRAKING

This section introduces regenerative braking, concepts behind the technology, what is currently being utilized, and how that technology might be retrofitted onto existing platforms. A detailed explanation of the technology and specific systems evaluated and additional possible benefits that go beyond the primary focus of this thesis is provided in a subsequent chapter.

Regenerative braking employs the concepts of kinetic and potential energy; it is a technology used to capture energy previously “lost” from the application of brakes. As such, regenerative braking utilizes a Kinetic Energy Recovery System (KERS). The “lost” energy is mostly in the form of heat, which occurs in the brake pads in the vehicle. This heat simply dissipates into the atmosphere, with all of it wasted. Through regenerative braking however, some of the energy can be captured and then re-harnessed to increase fuel economy. Because there is a delay between the application of brakes and reuse of this energy for acceleration, regenerative braking requires a storage system for the captured energy. This storage system can take the form of three different systems:

1) electrical, with the use of a battery; 2) mechanical, typically with the use of a flywheel; and 3) hydraulic system (Woodford, 2017).

Most often the captured energy is used for the acceleration and propulsion of a vehicle immediately following the application of brakes. Stop-and-go driving is the definitive scenario where regenerative braking is most often utilized. However, regenerative braking can be used for more than just propelling and accelerating a vehicle after the brakes are applied. Regenerative braking allows for an improvement to fuel economy by avoiding the use of the combustion engine to generate electrical power for ancillary equipment (e.g., by idling the engine). This break offered to the engine also possesses the ability to increase the life of the vehicle by reducing the effects of wear and tear.

Regenerative braking has been found to improve fuel economy between 10–30% depending on the vehicle type and duty cycle (Choi et al., 2015); the greater the level of improvement the more urban the environment. When driving on an open road fuel economy returns are limited since the application of the brakes is not necessary. This is typically of little concern since this is also when IC engines are typically operating at maximum efficiency. Fuel economy improvements are most substantial in stop-start traffic and where lots of idling occurs.

1. Current Uses

Regenerative braking was patented for an electric train in 1902. It is believed a Frenchman introduced the concept for a car in 1897, with the technology demonstrated at a Cycle Show in Paris that same year (Woodford, 2017). The community with one of the longest utilizations is Formula One racing, although its integration was mandated only as recently as 2009 (Evans, 2009, March 26). Regenerative braking did not however, become mainstream technology until the acceptance of the hybrid-electric vehicle.

The integration and use of regenerative braking in Formula One was made “in an effort to increase... and reclaim the recently questionable status of formula one as the ultimate automotive research and development series in the world” (Evans, 2009, March 26). From the KERS utilized, drivers can draw up to 60kW of energy per lap. The

energy is used “in the form of a ‘boost’ button” (Evans, 2009, March 26) giving the cars an extra burst of speed for certain maneuvers during the race. While most companies opted for the electrical version of regenerative braking, one ended up pursuing the mechanical version and is reported to have implemented a flywheel (Evans, 2009, March 26). With the passage of time, it is expected the allowable energy harnessed from regenerative braking will be increased, giving drivers even more power for longer periods of time.

2. Feasibility of Retrofitting

Today’s regenerative braking systems are implemented as a part of the drivetrain from the initial stages of design. While increasing effort is going into regenerative braking, hybrid vehicles, and even all-electric vehicles, this effort is geared toward the construction of a new system. Limited research is available on retrofitting vehicles with regenerative braking systems. Efforts would depend on whether harnessing the energy is accomplished with an electrical, mechanical, or hybrid system. For retrofitting, considerations would be paid to the addition of weight, required space, and as always, up-front monetary costs.

In 2009, academic teams in the United Kingdom successfully retrofitted a front wheel drive cargo van to “run in a zero-emissions, all-electric mode” (Evans, 2009, May 7) in an urban environment. The ADDZEV, or affordable add-on zero emission vehicle, as it was dubbed, was designed to turn off the IC engine and propel the vehicle with an electric power system integrated into the rear wheels. The range of the vehicle, utilizing only the battery power, was measured to be 12 miles, with a top speed of 37mph. The battery was able to be charged via two means: the mains or through regenerative braking (Evans, 2009, May 7).

“The ADDZEV system uses two liquid-cooled motors” (Evans, 2009, May 7) and can be retrofitted to any front wheel drive vehicle with an internal combustion engine. With the new system, the vehicle is transformed into a four-wheel drive, plug-in hybrid, capable of supplying up to 100kW and 350Nm of torque. Standard IC engines are only capable of providing 125 Nm. Operating costs are claimed to be reduced by up to 40%,

and while the team claims to have their method to be cost-effective, no dollar value was given for his effort (Evans, 2009, May 7).

The Solid Waste Program in Fairfax County, Virginia was awarded a grant from the American Recovery and Reinvestment Act to fund retrofitting of trash and recycling vehicle in 2011. The vehicle was retrofitted using a Bosch Rexroth parallel hydrostatic regenerative braking (HRB) system (Strauss, 2011). To make it a hybrid, a hydraulic pump/motor was connected to the drivetrain, which captured the kinetic energy generated through the application of the vehicle's braking system. Initial reports state the "new" vehicle will save up to 25 percent in fuel and energy costs (Strauss, 2011).

While the results of the experiment conducted in Fairfax County, Virginia could not be found, a report giving a brief overview of results from an equitable experiment conducted in New York was found. This experiment was part of a larger one, in which researchers were attempting to find the cost-savings of the retrofitted vehicle in an urban environment (New York City) and a suburban environment (Fairfax County) (New York State Energy Research & Development Authority [NYSERDA], 2011). Initial claims of cost-savings were the same as the experiment conducted in Virginia, with a prediction of 25% once introduced. This percentage, however, is generous, as it is the estimate for an ideal drive cycle (NYSERDA, 2011). Realized gains were significantly lower.

After operating for a year in Manhattan and Staten Island, the installed HRB system provided an improvement of 3.4% and 7.1%, respectively, in the vehicles' fuel economies (NYSERDA, 2011). Given the predicted 25% estimate was under an ideal scenario, the inclusion of "idling, refuse compaction/unloading, and transit (e.g., traveling to/from the garage, dump/transfer station, and the collection area) that do not engage the HRB system" (NYSERDA, 2011) significantly lowered the potential gains of the system. Despite this however, New York City still deemed the systems and the cost of retrofitting refuse/garbage trucks "a viable option for improving fuel economy" (NYSERDA, 2011) in their city's trucks and made the decision to purchase the installment of more HRB systems (NYSERDA, 2011). No details on dollar amounts, for either installation and amount saved, could be found.

3. Challenges of Retrofitting

While no reliable documentation or scholarly articles could be found to provide numbers behind the claim, historically the biggest reason for not retrofitting a vehicle with a regenerative braking system is that the components were cost-prohibitive. Additional arguments are that such an effort is extremely time-consuming and requires an advanced understanding of both mechanical and electrical systems on a vehicle.

Installation of a regenerative braking system usually requires integration with the vehicles' electrical system. This lies in the fact, as previously discussed, manufacturing and conversions utilize an electrical system for capturing and follow-on use of the energy gained from braking. Very rarely are mechanical means utilized. The required electrical considerations and modifications include: appropriate AC or DC motor for energy conversion; different or additional battery for energy storage; a battery management system (BMS), DC-DC convertor (Hanley, 2014, para. 13, 22). The larger or more sophisticated each of these elements, the greater the cost; however, also the greater regen capacity, hence fuel savings.

All these electrical additions and modifications contribute to the cost of labor. Given the complexity of a retrofit, the time required to make such modifications could be substantial. In fact, Hanley quotes that labor will cost a minimum of \$10,000 (Hanley, 2014, para. 4). The larger a vehicle and the more sophisticated a regenerative braking system (to include battery type and size, battery management system, charger, etc.), the greater the fiscal cost. A simple and "basic" conversion of a vehicle into a hybrid can be expected to cost around \$25,000, while a more advanced system on a larger vehicle utilizing a professional can require \$100,000 in funds or even more (Hanley, 2014, para. 24).

Given the lower estimate of \$25,000 for a regenerative braking retrofit, the effort does not seem defensible for a privately-owned vehicle, which could be purchased brand new with an already integrated regen system for a few thousand dollars more. The commercial trucking industry, however, is an industry in which a \$25,000 price tag may seem reasonable. With rising fuel prices, stricter emission standards, and poor worker

retention (NACFE, 2014) the long-haul trucking industry is seeking options to increase fuel economy and support a more pleasant working environment for their drivers. Hybrid conversions are becoming a popular answer.

Hyllion is a company that has developed an electric axle which can be retrofitted onto existing semi-trucks. The advertised price tag of this component is \$25,000 (Gilroy, 2018), with an advertised payback period of two years and a total life cycle ranging from seven to ten years (Gilroy, 2018). Hyllion's system integrates an electric axle which "captures" energy when the semi is traveling down-hill or applying the brakes. The captured energy is used for a range of activities, from propelling the truck forward after coming to a stop, to assisting the truck in going up steep hills, to performing hotel functions in the sleeper cab (Hyllion, n.d.). Hyllion's electrical system integrated into the drivetrain also ensures the diesel engine is maintained at its most efficient operating level (Hyllion, n.d.), further contributing to improved fuel efficiency.

Given the current market for such retrofits is currently limited, there exists a huge potential for growth and cost reductions for these systems. With increasing attention being paid to emission standards and the volatility of fuel prices, hybrid conversions for the commercial trucking industry present a unique opportunity for the DoD to capitalize on. Increased research and development into these components, along with improved learning curves and greater adoption rates, there is significant potential for retrofit efforts to become more economical and cost effective in the near future.

C. CURRENT PLATFORMS / HYBRID VEHICLES

When regenerative braking is mentioned, hybrid vehicles are the application people are most familiar with. A hybrid vehicle is characterized as one powered by both an internal combustion engine and an electric engine. A simplified depiction of a hybrid powertrain is displayed in Figure 1. Regenerative braking typically utilizes electrical components in order to capture and store the energy kinetic energy from braking, although occasionally mechanical means are utilized (i.e., a flywheel) (Woodford, 2017). The vehicles listed below are not an all-inclusive list of vehicles utilizing regenerative braking, however, are discussed due to their popularity and recognition.

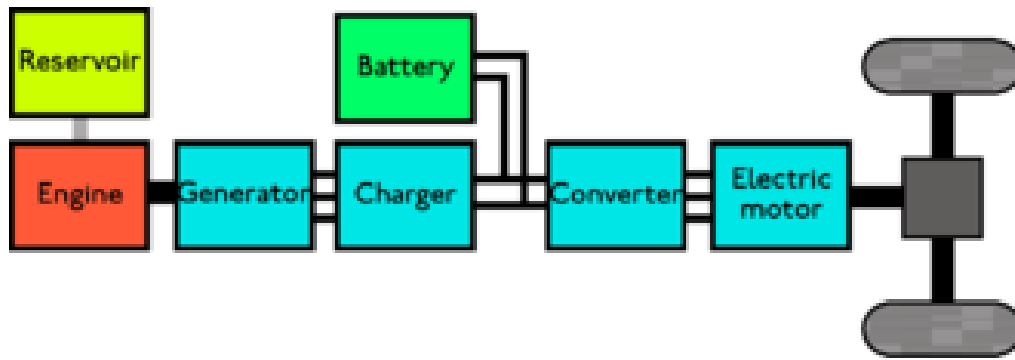

Figure 1. Basic powertrain configuration of a series hybrid vehicle.
Source: “Chevrolet Volt” (n.d.).

1. Toyota Prius

The first hybrid vehicle mass-produced for consumers was the Toyota Prius. The Prius made its debut in Japan in 1995, with production and sales starting in 1997 (Padgett, 2008, para. 1). The Prius did not however, become mainstream in the United States until approximately 2004 (Padgett, 2008, para. 6), and only after multiple upgrades from the original model debuted in Japan. Among these upgrades was the integration of regenerative braking. When braking is initiated, the Prius’ AC motor then becomes a generator, capturing the energy being applied to the brakes and transferring it to a battery to be stored for later use (Toyota GB, 2015). Other upgrades that enabled the second generation of Prius models to become more appealing to U.S. consumers was an improved relationship between the internal combustion engine and the electric motor, a larger combustion engine, reduced air drag, better raw materials, and a reduction in electrical drainage from components (Toyota GB, 2015). The updated Prius was able to travel 1.2 miles in all-electric mode (i.e., without the ICE) with a maximum speed of 31 mph (Toyota GB, 2015). Installation of a larger, high-voltage battery enabled the Prius to travel up to 14 miles without consuming any fuel at all. The updated drivetrain also significantly reduced idling time by shutting off the internal combustion engine during traffic stops (Toyota GB, 2015).

It is important to recognize the Prius, along with other hybrid vehicles, contain more than one battery type. Specifically, the Prius utilizes a Nickel Metal Hydride

(NMH) battery (The Clean Green Car Company, 2008) for its propulsion. The different types serve different purposes: one for starting the vehicle and another to store energy for use in propelling, or driving, the vehicle (The Clean Green Car Company, 2008). As these batteries serve different purposes, their composition requires different properties. These concepts, along with energy storage systems as a whole, are addressed in a later section of this chapter.

2. Chevrolet Volt

The hybrid vehicle to first knock the Prius from its top spot as a viable hybrid vehicle was the Chevy Volt, which was made available to consumers in 2011 (National Automobile Dealers Association [NADA], n.d.). While the Prius was the first mass-produced hybrid for consumers, the Volt was the first mass-produced electric car (NADA, n.d.). It does, however, still have an internal combustion engine (still qualifying it as a hybrid) as a backup source of power, which is required to travel long distances. The Volt's internal combustion engine utilizes electro-hydraulic regenerative braking, which increases the distance the Volt is able to travel (NADA, n.d.). The Volt initially had a (16kW) lithium-ion battery pack to enable such operation. This battery pack, coupled with two electric motors, generated up to 149hp (NADA, n.d.).

The Volt was initially designed with a powertrain with the ability to run off several different sources of energy to produce electrical power (Edsall, 2010). This capability is known as the E-Flex powertrain (Edsall, 2010). The E-Flex powertrain enables the Volt to run off power sources ranging from batteries alone, to fuel cells, or the unleaded fuel we currently fill up with at the pump. Similar to the initial models of the Volt, regenerative braking also plays a significant role in this powertrain, which is designed to provide additional electricity for “on-board” systems (Edsall, 2010). In a purely electric mode, the Volt has been recorded as being able to travel up to 50 miles before needing a recharge and subsequently engaging the internal combustion engine (Mayersohn, 2010).

3. Tesla

Another vehicle which enters the mind of consumers at the mention of the word “hybrid” is the Tesla brand. This is a misconception as the vehicles produced by Tesla are not hybrids, as an internal combustion engine is not part of the drivetrain. Tesla vehicles are purely electric, operating off the electrical energy produced by fuel cells alone. An overview of Tesla is provided however, as it is increasingly a significant topic of conversation in reducing dependence on fossil fuels and the fuel cells’ capability to provide a source of power. Additionally, regenerative braking is built into the drive train, operating automatically when a driver’s foot is released off the accelerator. Little to no human involvement is required for regenerative braking to happen.

Tesla first broke onto the scene with its production of the Roadster in 2005. At the time of its manufacturing the Roadster’s engine was modeled after a design by Nikola Tesla from the late 1800s and utilized an AC motor (Michaels, 2010). Three years later, the Roadster was updated and was the first vehicle to utilize lithium-ion batteries. The first version was reported as being able to travel distances greater than 200 miles before needing a re-charge (Boylan, 2016).

A platform recently developed and marketed by Tesla with potential implications for this thesis is the Tesla Semi, slated to start production in 2020 (Alvarez, 2018). As Tesla’s battery-electric drivetrain provides a new era in commercial vehicles, the Tesla Semi provides an opportunity to significantly reduce fuel costs in long-haul trucking and logistics. With an initial promise of a range of 400 miles after a 30-minute charge (Smith, 2017), the Tesla Semi points to the potential to increase ranges of future military logistics vehicles.

D. ENERGY STORAGE SYSTEMS (BATTERIES)

A vital component of introducing regenerative braking to military vehicles is the integration of an energy storage system. This is especially true since the purpose of this analysis focuses on utilizing the captured energy not for immediate acceleration and propulsion, but to power on-board ancillary systems. As previously discussed, early developments of regenerative braking were to utilize the energy captured from braking

for follow-on propulsion by stepping on the accelerator. This is why stop-and-go, or urban driving, is the most ideal environment in which to recognize the benefits of regenerative braking. In such an environment, there is very little lag from capturing the energy and using it again. In this report's analysis the authors account for the likelihood there will be a significant amount of time between when the energy is captured to when it is utilized. This lies in the assumption our soldiers do not utilize a majority of the power-draining systems aboard the tactical vehicles until at a stand-still.

As such, it is imperative the vehicles also be made capable of storing the captured energy for follow-on use. This analysis, therefore, considers the addition of: newer and better batteries; solar panels; anti-idling device with a supercapacitor and emergency over-ride; and regenerative braking systems. While follow-on chapters address the specifics regarding the type of "systems" analyzed, this section addresses several different types of batteries. This section is by no means all-inclusive. Instead, the authors chose the types of batteries most likely to be encountered in traditional vehicles [utilizing a combustion engine] and hybrid vehicles.

1. Characteristics

Batteries are judged and subsequently chosen on several defining characteristics. These factors include but are not limited to: up-front and lifetime costs; life cycle and/or calendar life; safety; specific power/power density; specific energy/energy density; self-discharge rate; and amount of time it takes to fully charge the battery. Some of these factors are significant in their application for regenerative braking and powering ancillary systems (Cruse & Sims, 2017).

Two important factors to pay attention to are specific energy (also referred to as energy density) and specific power (also referred to as power density). Higher levels of specific energy translate to an ability to power ancillary systems for longer periods of time. In the context of this thesis, it "translates into improved silent watch performance (Cruse & Sims, 2017, p. 3)." A higher specific power rating equates to a greater ability to power those systems which require high levels of energy, such as a Remote Weapon System. In regard to retrofitting a vehicle with a regenerative braking system, attention

should also be paid to voltage. Oft times, the nominal voltage is what prevents a system from being a drop-in replacement. Regenerating braking can produce extremely high currents. For a battery to be capable of “accepting” the high currents generated from braking, it must be rated for a “high level of... charge acceptance” (Crase & Sims, 2017, p. 13). In the Data Analysis chapter, this often proves to be a limiting factor of the systems analyzed. While a high level of energy is produced, only so much could be captured. Table 1 later in this chapter provides an overview of the types of batteries and their characteristics discussed in this chapter.

2. Lead Acid

Lead acid batteries are addressed first as they are what consumers are most familiar with; this is the type of battery vehicles with a combustion engine currently utilize (Ceraolo et al., 2011). The two types of lead acid batteries most commonly utilized are SLI (Starting, Lighting, Ignition) and deep-cycle batteries (Crase & Sims, 2017). Each serve different purposes, with SLI batteries acting as its name implies: ignition and starting of the vehicle in which it’s installed. Early models of the Prius utilized this type of lead acid battery, also known as the “low voltage” battery to serve the purpose its name implies: to simply start the car (Padgett, 2008). Deep-cycle batteries are also called traction batteries and are used in smaller electric vehicle platforms, such as forklifts and golf carts, as they are capable of providing a relatively continuous level of power over a longer time period (Dahn et al., 2011; Farret & Simoes, 2006). Lead acid batteries are also the batteries currently utilized in a majority of military tactical vehicles today (Catherino, 2006).

Lead acid batteries have remained relevant due to their lower cost, reliability, and relative safety (Crase & Sims, 2017). One of the strongest advantages of lead acid batteries that have contributed to their being the primary choice of military vehicles is their ability to withstand a wide range of “abusive” environments (Crase & Sims, 2017). Additionally, SLI lead acid batteries possess a relative high level of specific power (235 W/kg) (Pavlov, 2011), which is necessary for their primary role in cranking and turning the engine over (Crase & Sims, 2017).

Despite their high specific power, lead acid batteries have found to be lacking in energy density, which ranges from 25-40 Wh/kg (Cruse & Sims, 2017). This characteristic makes them a poor solution for “silent watch” activities (Cruse & Sims, 2017), as they will quickly run out of energy to power on-board electrical systems. Another drawback of lead acid batteries is their relative inability to be stored “in a discharged state... which [causes] decreased capacity” (Cruse & Sims, 2017) and irreversibly reduces their service life. Compared to other batteries being developed, SLI lead acid batteries also have shorter life cycles, ranging between 200-700 cycles (Cruse & Sims, 2017), which equates to more frequent replacements.

While deep-cycle lead acid batteries have greater life-cycles compared to their SLI counterpart, they are still subject to the previously listed disadvantages. Because they have a lower specific power, they are unable to provide the high level of initial energy required to start a vehicle, hence the different role they play. Prohibitive factors in outfitting a vehicle with both a SLI and deep-cycle lead acid battery in order to fulfill both functions is their significant weight and size (Cruse & Sims, 2017). Additional considerations regarding the architecture of a vehicle would have to be made to mount both types of lead acid batteries.

Although more mature in their development than other types, lead acid batteries are still undergoing further developments and improvements (Cruse & Sims, 2017). Despite their shortcomings, it is predicted they will remain relevant for vehicles, especially in the military (Cruse & Sims, 2017).

3. Nickel Metal-Hydride (Ni-MH)

Ni-MH batteries have become common in hybrid vehicles (Dahn et al., 2011). This is the type of battery the Toyota Prius utilized as its “high voltage” battery to capture and store the energy from braking (Cruse & Sims, 2017). Ni-MH batteries provide greater specific energy (90-110 Wh/kg), energy density (430 Wh/L), specific power (865 W/kg), and cycle life (500-1000 cycles) than the typical lead acid battery (Cruse & Sims, 2017). Given these characteristics, Ni-MH batteries provide an opportunity for better silent watch operations. An added benefit is that Ni-MH batteries are also relatively safe

(European Automotive Manufacturers Association [EAMA], 2014) and require no regular maintenance or up-keep (Dahn et al., 2011).

Disadvantages of Ni-MH batteries are their voltage compatibility, ability to serve as a drop-in replacement, and ability to be continuously discharged and recharged numerous times over (Dahn et al., 2011) which is a common side-effect of urban driving and incorporating regenerative braking. This is known as the “memory effect” (Cruse & Sims, 2017), and when not regularly charged to full capacity the battery appears to “forget” how to retain a high level of charge. This effect, however, is treatable. The battery’s initial capacity can be restored with several cycles of fully discharging the battery (Dahn et al., 2011).

Another disadvantage of Ni-MH batteries as compared to lead acid are their cost. While more expensive than lead acid batteries they are, however, cheaper than lithium ion alternatives, which will be addressed next. Similarly, while possessing a higher specific energy than lead acid batteries, the level is lower than that provided by lithium ion (Cruse & Sims, 2017). They also suffer from significant performance degradation in colder temperatures (Dahn et al., 2011). They are also sensitive to higher temperatures, as their ability to accept charge at such levels is decreased (Cruse & Sims, 2017). This can be compensated for by thermal management of the battery.

Given the advantages of Ni-MH batteries are in relation to lead acid batteries and its drawbacks are in comparison to lithium ion, Ni-MH batteries possess the potential to be a “middle-of-the-road” solution for improved performance. Given the rapid advances in lithium ion battery development and Ni-MH batteries susceptibility to operating temperature ranges, incorporation of Ni-MH batteries into our tactical vehicles remains questionable (Cruse & Sims, 2017).

4. Lithium Ion (Li-ion) Batteries

Li-ion batteries and their development have skyrocketed over the past several years and they are proving to be a disruptive technology. As the demand for hybrid and electric vehicles have grown, so has the use of Li-ion batteries in such platforms.

Different versions are used in the Chevy Volt (NMC), Nissan Leaf (NMC) Tesla models (NCA). As such, discussion regarding their use in military tactical vehicles is increasing.

Li-ion batteries have significantly greater specific energy, ranging between 100-240 Wh/kg; higher energy density, ranging from 250–640 Wh/L (Cruse & Sims, 2017); and a greater cycle life, ranging from 500 to 1,000 cycles (Dahn et al., 2011). Their high cycle life presents the possibility of never having to replace the battery in a vehicle's lifetime (Dahn et al., 2011). The higher levels of energy for Li-ion can be contributed to their "higher operating voltage" (Cruse & Sims, 2017), which is almost twice that of a typical lead-acid and three times as much as Ni-MH cells (Dahn et al., 2011). "This means that fewer [Li-ion] cells are required for a battery of a given voltage and [can therefore] be made smaller and/or lighter" (Cruse & Sims, 2017, p. 20). These higher levels of energy equate to an ability to provide significant power for longer periods of time than lead-acid and Ni-MH batteries are capable of. This makes them a prime candidate for silent watch operations. Li-ion batteries also require little to no maintenance, do not suffer from the "memory effect" like Ni-MH, and have a low self-discharge rate of 2-10% per month, which allow them to be stored for longer periods of time without significant degradation in performance (Dahn et al., 2011).

Despite these advantages, Li-ion batteries have a number of concerning properties which have prevented more widespread adoption. Of primary concern is their "thermal stability" (Cruse & Sims, 2017) and safety properties (Dahn et al., 2011). This was evidenced by the numerous self-combustions experienced by consumers in their Samsung phones in 2016. While this was considered an anomaly in the realm of cell phones, it possesses concerning implications for the military, as a puncture in the battery say, during an IED attack, is a very real threat and can result in dire consequences. Thermal runaway can also result from overcharging, over-discharging, or operating in too hot of temperatures (Dahn et al., 2011)—all of which are real possibilities in a military environment. Li-ion batteries also have lower performance in cold temperatures (Huang et al., 2000). Finally, Li-ion batteries are significantly more expensive (Dahn et al., 2011). The life cycle costs of Li-ion batteries as compared to lead acid are debatable,

however. Given the reduction in maintenance and possibility of never needing a replacement, there exists the possibility overall costs may be lower (Cruse & Sims, 2017).

The batteries incorporated into this analysis (Navistas 6T Li-ion battery) are lithium iron phosphate (LFP) batteries. Of the li-ion types, LFP promise to be the most realistic for the Marine Corps. LFP batteries are considered the safest of the li-ion battery family and are cheaper than other Li-ion options, have a significant life cycle, are environmentally friendly, have been developed to support drop-in replacement, are able to be fast-charged, and most do not require a complex thermal management system (Cruse & Sims, 2017). LFP batteries, however, have a lower specific energy compared to other Li-ion counterparts; although the specific energy provided is still greater than that offered by lead acid batteries currently utilized.

5. Capacitors

A capacitor is a device that stores potential energy in an electric field (Duff, 1919). Capacitors are capable of holding a significant amount of energy however, not in the same sense as a battery. The energy a capacitor holds is quickly released and not suitable for supplying a sustained level of energy. While a capacitor may not appear as suitable in integration for supplying a power source for military vehicle's on-board ancillary systems, there is potential for them to play a significant role, depending on the architecture of choice.

As already discussed, the lead acid batteries in vehicles with internal combustion engines provide the initially high level of power required to start the engine. From there, the alternator in the engine takes over to power the vehicle and all its integrated systems, in addition to recharging the battery that was just drained in starting the vehicle. Typically, once a vehicle's lead acid battery is drained, it is unable to start. Because of lead acid batteries' relative inability to provide high levels of power over a prolonged period of time, vehicles are idled in order to power necessary on-board systems.

Capacitors are mentioned in this thesis not as a means to supply a continual source of power, but as an alternative or backup to provide the high level of voltage required to cold-start an internal combustion engine. This guarantees that, no matter

what type of system is in place, the vehicle will always be capable of starting up again. It is possible that integration of capacitors alone possesses the potential of reducing fuel costs by reducing the need to idle a vehicle's engine.

E. BATTERY MANAGEMENT SYSTEMS

As vehicles have seen an increase in electrical components, Battery Management Systems (BMS) are becoming an increasingly important feature. This is especially true for system utilizing Li-ion and Ni-MH batteries (Flynn et al., 2004). A BMS helps offset many disadvantages by helping control and manage temperature, charging, discharging, voltage, and pressure within the battery (Ceraolo et al., 2011). Some batteries come with a BMS already installed in the battery architecture (Cruse & Sims, 2017). If this is not the case however, additional adjustments must be made to the vehicle to account for the additional, or new, battery.

Table 1. Summary of Battery Characteristics. Adapted from Crase and Sims (2017).

BATTERY TYPE		Voltage (V)	Specific Energy (Wh/kg)	Energy Density (Wh/L)	Specific Power (W/kg)	Power Density (W/L)	Cycle Life (cycles)	Calendar Life (yrs)	Self-Discharge Rate (%/mo)	Optg Temp (degC)
Lead-Acid	Flooded (SLI)	2.0	40	80	215	445	200-700	3-6	20-30	-40 - +55
	Flooded (Deep-cycle)	2.0	25	80			1500	6	4-6	-20 - +40
	Sealed (AGM)	2.0	30	95	235	570	300-450	3-4	4	-15 - +50
Nickel-based	Ni-MH	1.2	90-110	430	865	2882	500-1000	5-10	15-30	-20 - +65
Li-ion	NMC (Energy cells)	3.6	175-240	400-640	~1000	~2000	>500	>5	2-10	-20 - +60
	NMC (Power cells)	3.6	100-150	250-350	~4000	~10000	>500	>5	2-10	-30 - +60
	NCA	3.6	175-240	400-640	~1000	~2000	>500	>5	2-10	-20 - +60
	LMO	3.7	100-150	250-350	~4000	~10000	>500	>5	2-10	-30 - +60
	LFP	3.3	60-120	125-250	~4000	~10000	>1000	<5	2-10	-30 - +60

F. FULLY BURDENED COST OF FUEL (FBCF)

The Fully Burdened Cost of Fuel, or FBCF, is a significant cost driver in military operations; both in tactical and training environments. The cost of fuel in a tactical environment, which is predominantly austere and hostile, invariably accounts for a significant portion of expenditures and is of growing concern to Congress and the DoD (Advanced Policy Questions, 2017). During his fielding of preliminary questions for the Armed Services Committee, SecDef James Mattis stated that our military “faced...unacceptable limitations because of their dependence on fuel” (Advanced Policy Questions, 2017). While regenerative braking would not altogether remove this tether, it could reduce the limitations imposed by the burden of fuel.

The FBCF is the cost of everything it takes to deliver fuel to the warfighter. Specifically, the fiscal year (FY) 2009 National Defense Authorization Act (NDAA) defined FBCF as “...the commodity price for fuel plus the total cost of all personnel and assets required to move and, when necessary, protect the fuel from the point at which the fuel is received from the commercial supplier to the point of use” (H.R. 5658, 2009). This definition proves to be quite convoluted when we pull apart what it truly means and therefore, are able to get a more complete picture of determining the fully burdened cost of fuel. Since 2009 the Department of Defense (DoD) has extended this definition to apply to not just fuel, but more broadly, all those items that contribute to providing power and electricity. As such, FBCF has expanded to be the Fully Burdened Cost of Energy (FBCE). While fuel is inherent, and a baseline contributor of energy, FBCE now encompasses the use and associated cost of generators, batteries, and other power systems (i.e., host-nation power grid) utilized by our nation’s military (Bohnwagner, 2013).

The FBCE is dependent upon three characteristics: scenario, time, and location (Bohnwagner, 2013). These characteristics are driving factors in determining two out of the three elements of the FBCE: the cost to tactically deliver these energy providers and the security and force protection required to protect them. Table 2 provides an overview of the elements and their associated definitions.

Table 2. Elements and Definitions of the Fully Burdened Cost of Energy.
Adapted from Bohnwagner (2013).

Element #	Price Element	Burden Description
1	Fuel Commodity Price	DLA Energy capitalized cost to purchase, transport, store, and manage fuel to the Point of Sale at the edge of the scenario battlespace.
2	Tactical Delivery Assets Burden*	Includes all of the following:
	Fuel Delivery O&S Price	Per gallon price of operating service-owned fuel delivery assets including the cost of military and civilian personnel dedicated to the fuel mission.
	Depreciation Price of Fuel Delivery Assets	Measures the decline in value of fuel delivery assets with finite service lives using straight-line depreciation over total service life.
	Infrastructure, environmental, and other miscellaneous costs over/above and distinct from the DLA Energy capitalized cost of fuel	Per gallon price of the infrastructure, regulatory compliance, tactical terminal operations, and other expenses as appropriate.
3	Security/Force Protection Assets Burden*	Per gallon price associated with delivering fuel, such as route clearance, convoy escort and force protection. Includes the manpower, O&S, and asset depreciation costs of the force protection.
*These prices vary by Service, delivery method (ground, sea, air) and delivery location.		

The commodity price is arguably what people are most familiar with. As defined in Table 2, this is the cost of the fuel the Defense Logistics Agency (DLA) pays to “purchase, transport, store, and manage fuel to the point of sale” (Bohnwagner, 2013). This point of sale may be the gas station used by service members on their state-side base, or it may a location overseas before service members must take the fuel to the outer edges of the area of operations.

It is the second part of the definition of FBCE that adds the significant cost, or “burden,” to providing energy. “The total cost of all personnel and assets required to move and, when necessary, protect the fuel” has far reaching implications in a hostile environment (Bohnwagner, 2013). Moving and protecting energy sources generates wide-ranging cost differences, depending on the service, how the fuel is moved, and the type and size of the security needed to protect its transportation and storage in an austere location. This third element is arguably the most costly, not only in terms of dollars, but in the lives of personnel who are often given in an effort to transport and protect it along the route. A study conducted by the Marine Corps found that a life was lost every 24 fuel resupply convoys conducted in Afghanistan (Eady et al., 2009). Since the scenarios and elements determining the burden of a gallon of fuel in a hostile environment is always in flux and fluid, the exact cost is difficult to pinpoint, but is sometimes extremely high. As an example, the price of a gallon of fuel in Afghanistan has been quoted as being as high as \$600 (Dimotakis et al., 2006).

The burden of fuel is a part of the cost of war, or any foreign engagement. There are actions however, that can reduce the burden. While regenerative braking does not offer a definite solution to the “tether of fuel” (Advanced Policy Questions, 2017) nor remove all limitations, it does offer the promise of reducing the burden of fuel.

1. Sourcing Fuel in an Austere Environment

The introduction of regenerative braking can help reduce the cost of energy while also providing other advantages to tactical vehicles. The primary reason the cost of fuel is significant in the military is the austere environments in which our forces must operate. Austere environments present numerous challenges, ranging from limited infrastructure to hostile actors that inherently contribute to the “burden” of fuel. These environments, coupled with the operating doctrine of the services, require the services to be self-sustainable. The Marine Corps specifically, utilizes MCRP 3-40B.5, “Petroleum and Water Logistic Operations,” as a baseline in how to handle fuel.

The ability for a tactical vehicle to fill up its fuel tank in an austere environment requires a significant support infrastructure (see element 2 in Table 2), which depends

heavily on the host nation in which the Marine Corps is operating. “A mature or developed theater will usually have host nation (HN) infrastructure assets available such as pipelines, storage facilities, and railways that will help support the bulk petroleum distribution system” (Department of the Navy [DoN], 2016, p. 1-1). When the Marine Corps conducts operations in a developed theater, it relies highly on bulk petroleum distribution; fuel is expected to be readily available and the establishment of an infrastructure to provide fuel to Marine forces is focused on coordinating with host nation organizations. In an undeveloped theater however, “host nation or commercial bulk fuel facilities normally will not be available; therefore, tactical assets will have to be used. The bulk fuel supply system in the undeveloped theater may include limited tanker mooring systems, floating or submerged hose lines, and tactical fuel systems” (DoN, 2016, p. 1-1). When the Marine Corps conducts operations in an undeveloped theater, the Marine Corps may still be required to coordinate with host nation organizations. The establishment of the bulk fuel distribution system, however, becomes the responsibility of the Marine Corps, which must utilize its equipment to provide fuel to the warfighter.

The coordination for the establishment of a bulk fuel distribution system in an undeveloped theater is the responsibility of the Marine Expeditionary Force, under the direct supervision of its Bulk Fuel Chief Warrant Officer. The distribution of bulk fuel within the theater is aided by the Logistics Combat Element (LCE), where Combat Logistic Battalions (CLBs) are primarily responsible for the transportation of fuel via convoy operations. The storage and dispensing of bulk fuel is also the responsibility of Bulk Fuel Companies, located within the LCE’s Engineer Support Battalions (ESBs).

The Bulk Fuel Companies utilize the Marine Corps’ Amphibious Assault Fuel System (AAFS), a modular bulk fuel distribution system with a storage capacity of 600,000 gallons (DoN, 2016). The AAFS has the capability to source bulk fuel from a beach head (connected to a Maritime Prepositioning Ship) and transfer its product to up to five collapsible tank farms via a hoseline system (DoN, 2016). Where the theater’s landscape is not conducive to a hoseline system, the CLBs are utilized to transport and distribute fuel via M970 semitrailer refuelers.

The variety of missions the Marine Corps conducts in undeveloped theaters forces the development of Standard Operating Procedures (SOP) that are specific to bulk fuel missions. These SOPs typically capitalize on the modular design of the AAFS by distributing its tank farms throughout the area of operation to provide fuel resupply points for the entire operating force. The tank farms are modular in design, capable of being broken down further to smaller capacity tank farms where the only limiting piece of equipment is the distribution system's fuel pumps where a minimum of two pumps are needed at each tank farm (DoN, 2016). These tank farms, regardless of capacity, all have the capability to dispense fuel to the entire Marine Corps vehicle fleet.

The ability to source bulk fuel in underdeveloped countries demands more coordination from Marine Corps logisticians and engineers. This demand equates to a larger footprint of personnel and equipment in the area of operations and greater vulnerability to the operating forces. A reduction in bulk fuel consumption in the area of operations would help reduce the overall footprint and logistical and supply requirements for the Marine Corps.

2. Powering Auxiliary Systems

The austere environment in which the Marine Corps operates requires its maneuver units to be self-sufficient—to an extent. Units are expected to mitigate risk by ensuring they are equipped with the correct gear and amounts of classes of supply to endure the duration of the mission and have a reliable means to resupply their Marines. Part of that self-sufficiency in units who possess and regularly operate motor transport assets is their reliance on the internal combustion engine of vehicles.

The Marine Corps' two primary logistics vehicles both have variants of auxiliary equipment that either enhance or are an integral part of a unit's mission capability. The Wrecker variants provide a recovery capability through the use of slave cables, cranes, winches and pneumatic tool sets (OSHKOSH, n. d.). The power for these auxiliary systems is normally provided by the vehicles' engine, requiring it to idle during the employment of the auxiliary systems. This consumes fuel that could otherwise be used

for driving. Depending on the duration of the auxiliary systems' use, the vehicles will require refueling sooner than if the fuel was only used to drive the vehicle.

There are additional auxiliary systems the Marine Corps uses in austere environments that are not necessarily integrated into the vehicles but are critical to the accomplishment of the mission. An example is a unit's command and control assets. When maneuvering throughout the battlespace a unit will typically establish a Forward and a Main Combat Operations Center (COC). These two elements will maneuver in a "leap-frog" pattern, with one maintaining command and control of the operating forces while the other is in transit. This pattern of maneuver requires the engines of the vehicles to remain idling while stationary, which consumes their limited on-board fuel resource.

As development of technology advances, so too does the demand and requirement for advanced systems on board vehicles. These assets range from simple radios to complex command and control assets, computers, and even weapons systems. The type and number of these auxiliary systems on tactical vehicles depends on a unit's particular mission and the role the particular vehicle plays. In order to stay ahead of an adaptive enemy, the USMC has added more auxiliary systems to vehicles in recent years.

This thesis identifies regenerative braking systems as one means to power these auxiliary power systems that will inherently improve the Marine Corps' tactical vehicles' fuel consumption. These systems can ultimately lower the fuel consumption rate of vehicles by reducing or eliminating the need to idle the vehicle's internal combustion engine to power the on-board auxiliary systems.

3. Idle-Reduction Considerations

As previously mentioned, tactical vehicles are often left idling, which most times consumes limited fuel resources with no return or completion of work. The justification for idling a vehicle's engine range from the need to properly prepare for convoy operations (getting into proper order, conducting pre-combat checks/inspections, etc.), to the desire to maintain a comfortable ambient temperature (i.e., staying cool or warm in adverse weather conditions), to the need to maintain a proper charge on the battery. The last argument is arguably the most significant, as a dead battery in a hostile environment

presents substantial risk. While reducing idling is not an energy recovery system, it is a simple and straightforward means of improving fuel efficiency.

While the Marine Corps does not possess any data on the amount of time its tactical vehicles spend idling or subsequently how much fuel is wasted (Gallenson & Salem, 2014), the commercial trucking industry has invested considerable effort to address the waste associated with idling. In 2014, NACFE estimated that approximately 6% of the time commercial trucks spent idling could be avoided, and thereby save over two billion gallons of fuel (NACFE, 2014). Given their relatively low price, ease of integration and the potential to save over \$5,000 per tractor trailer per year (NACFE, 2014), the adoption of idle-reduction technologies in the commercial trucking industry have skyrocketed (see Figure 2).

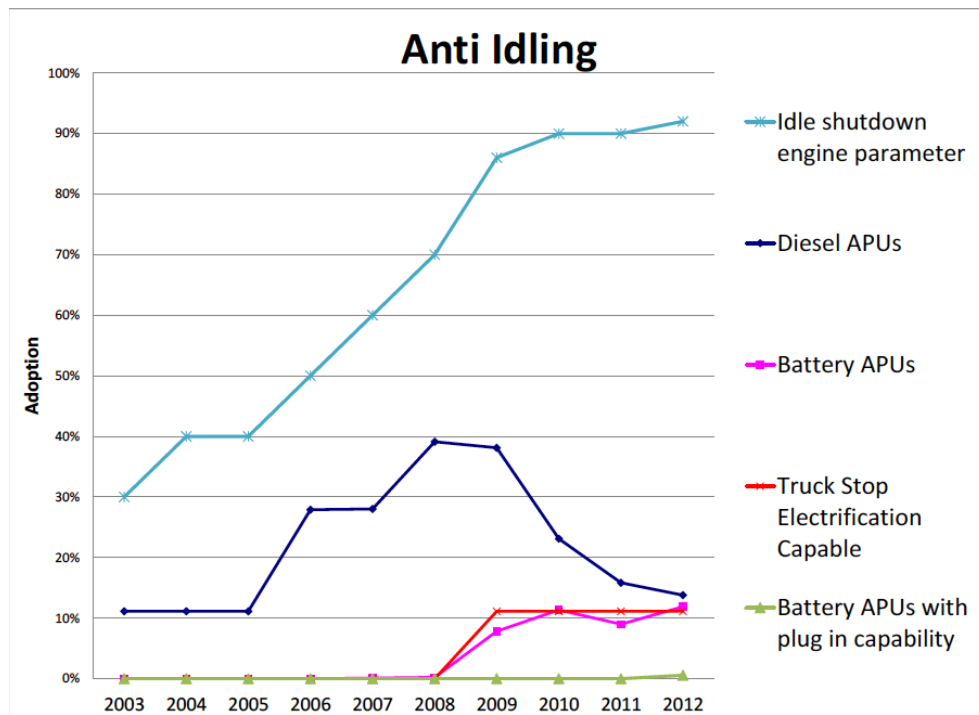

Figure 2. Adoption rates of different fuel improvement technologies in the commercial trucking industry. Source: NACFE (2014).

Despite the promise of such returns, there remains appears to be heavy resistance to idle-reduction in the military. Similar to the commercial trucking industry, some of the reason lies in lack of knowledge and access to data (NACFE, 2014), in addition to a deeply imbedded culture of where effectiveness and risk reduction trump efficiency (Gallenson & Salem., 2014). A key issue is the fear of a vehicle being unable to start once it has been stopped. Operators, therefore, prefer to idle the vehicle in order to eliminate this risk. In an operational environment, however, this merely transfers risk to those that must bring more fuel than would otherwise be needed into the operational zone, with all the proven dangers that this involves.

It is recommended the term “idle reduction” is used instead of “anti-idling” or “zero idling” (Gallenson & Salem, 2014). Semantics alone have proven to make leaders and drivers alike more amenable to incorporating the technology (NACFE, 2014).

G. USMC [LOGISTIC] TACTICAL VEHICLES

The Marine Corps’ two primary logistics vehicles are the Medium Tactical Vehicle Replacement (MTVR) and the Logistics Vehicle System Replacement (LVSR). Each vehicle platform provides a wide variety of transportation capabilities to the warfighter. A standardized chassis, engine, and drivetrain are compatible with multiple cargo bed configurations to best suit the equipment requirements of a unit’s table of equipment. The Joint Light Tactical Vehicle (JLTV) is a program of record currently being processed through the Defense Acquisition Systems and is be discussed briefly as it relates to this thesis and its research.

The previous version of the MTVR, the M923 5-ton cargo truck, was fielded in 1982 (General Accounting Office [GAO], 1999) and replaced in 2001 (Jane’s, 2015), giving it a service life of at least 19 years. The LVSR’s predecessor, the LVS, was fielded in 1985 (Lamothe, 2009) and began its retirement phase in 2009 (Jane’s, 2016), giving it a service life a minimum of 24 years. Current policies, practices, and budgetary constraints suggest that the MTVR and LVSR will have longer service lives than their predecessors.

1. Medium Tactical Vehicle Replacement

The MTVR, often referred to as the “7-ton,” is the workhorse of the Marine Corps. The MTVR has been in service to the Marine Corps since 2001 and is the replacement for the “service’s aging 5-ton truck” (Program Executive Officer [PEO], 2012). The MTVR is a six-wheeled, multipurpose vehicle that “hauls fuel, water, and supplies, as well as Marines, and also the M777 Lightweight 155mm howitzer” (PEO, 2012). The MTVR is built by the OSHKOSH Defense Corporation and they manufacture “four ... models, each carrying a crew of three Marines in its cab: a cargo variant, a dump truck, a wrecker [maintenance vehicle with towing capability] and a tractor” (PEO, 2012). The Program Executive Officer Land System Advanced Technology (PEOLSAT) Investment Plan of 2012 summarizes the performance capabilities of the MTVR in the following paragraph:

- The predominant standard cargo variant is 26 feet long, 8 feet wide and 12 feet high. It can haul up to 15 tons of payload on paved primary or secondary roads to a maximum speed of 65 miles per hour, or can carry 7.1 tons cross country. The MTVR can traverse a 60 percent gradient and a 30 percent side slope with its maximum cross-country load, and can ford 5 feet of water. It has an on-road cruising range of 300 miles. (p. 1)

The MTVR’s drivetrain is powered by a “425-horsepower Caterpillar engine, an Allison 7-speed automatic transmission, [and] anti-lock brakes with automatic traction control” (PEO, 2012). The PEOLSAT Investment Plan of 2012 identifies the top three program issues with the MTVR: Fuel Economy, Current & Future C4I Integration Demands, and Increased Survivability (PEO, 2012). The issue of fuel economy is of special interest to the topic of this thesis. The MTVR’s fuel economy of 3.8 miles per gallon is a prime target for researchers and developers to identify any means available that could improve it (PEO, 2012).

The PEOLSAT Investment Plan of 2012 identifies regenerative braking as one of the many projects being explored to increase fuel economy. Other endeavors include engine mounted fuel efficiency technologies, accessory electrification, and hybrid and electric drives (PEO, 2012). Any technological efficiencies being considered for

application to the MTRV must consider the extreme weather conditions in which the vehicle is expected to operate. The effective temperature range for a MTRV is “from -25° F to 125° F; [and] with the use of artic kits, consisting of an extra battery and an engine heater, MTRVs are capable of operating in -50” (Navy Education and Training [NAVEDTRA], n.d.). The MTRV’s versatility presents a wide range of potential technologies to explore to increase its fuel economy beyond 3.8 miles per gallon. Regenerative braking has the potential to not only positively contribute to the MTRV’s fuel economy but also to reduce its noise and heat signature while stationary.

2. Logistic Vehicle System Replacement

The Logistic Vehicle System Replacement (LVSR) is a heavy tactical vehicle utilized for lifting, hauling, and transporting supplies and equipment throughout an area of operations. It is unique to the Marine Corps and was developed by OSHKOSH Defense Corporation. The LVSR was designed and upgraded to replace its predecessor, the Mk48 Logistic Vehicle System (LVS), beginning in the 1990s. The LVSR started to make its way in the fleet operating forces around 2009 (Oshkosh Logistic Vehicle System Replacement (LVSR), n.d.). While the LVSR is known for its significant lift capability, two other variants with different purposes exist: the MKR 15 Wrecker and MKR 16 Tractor.

The LVSR is slightly larger, heavier, and more powerful than its predecessor. It has an integrated Load Handling System (LHS) that makes the pick-up, drop-off, and transportation of supplies and equipment more efficient and effective. It was also designed with an integrated Command Zone and diagnostics technology (Oshkosh LVSR, n.d.). Table 3 summarizes the LVSR specifications. While it was originally programmed for a 22-year service life and fielding beginning in FY 2009, there is currently no discussion or planning for a replacement or upgraded vehicle (Gourley, 2012).

Table 3. LVSR Specifications. Adapted from “Oshkosh Logistic Vehicle System Replacement (LVSR)” (n.d.).

Dimensions (length x width x height)	432.2” x 98” x 102” (161.9” high when loaded with container)
Weight	53,670# (59,900# with armored kit; gross weight of 106,000#)
Fuel tank, economy, consumption	166gal / 2mpg / 20 gal/hr
Payload	22.5 ton (on-road); 16.5 ton (off-road)
Engine	Caterpillar C-15 15.2-liter, 6-cylinder turbocharged inline water-cooled 600hp (448kW) diesel engine (1800rpm, 2508Nm torque at 1200rpm), 7 speed automatic transmission, single speed transfer case, front tandem steering and driving axles, and rear tridem driving axles of which two rear most axles steer
Transmission	Allison 4700SP 7-speed automatic and OSHKOSH 35000 single-speed transfer case
Suspension	OSHKOSH TAK-4 independent; front axles rated for 7,666kg and rear axles for 10,478kg
Steering	Power-assisted; 1st, 2nd, 4th, and 5th axles (4th and 5th axles mechanically controlled)
Towing capacity	53,000# gross trailer weight w/ LHS

3. Future Generation Tactical Vehicles—The Joint Light Tactical Vehicle (JLTV)

It appears the MTRV and LVSR will be the medium and heavy logistical vehicles the Marine Corps will employ for the foreseeable future (Gourley, 2012). The High Mobility Multipurpose Wheeled Vehicle (HMMWV) however (which was introduced in 1985), is scheduled to be phased out and replaced by the Joint Light Tactical Vehicle (JLTV). Similar to the MTRV and LVSR, the contract belongs to OSHKOSH Defense. Variants of the JLTV currently include: armament carrier; utility truck; command and control (C2)/shelter; ambulance; reconnaissance; plus others to fulfill other tactical and logistic support roles (“Joint Light Tactical Vehicle,” n.d.). The JLTV Program was initiated to replace the high mobility, multi-wheeled vehicle (HMMWV), which has been in operation since 1985, and to ultimately provide the Army and Marine Corps with a light tactical vehicle that is “mechanically reliable, maintainable..., all-terrain mobile”

and with the same level of survivability and force protection as the Mine-Resistant, Ambush-Protected All-Terrain Vehicle (M-ATV) (Feickert, 2018). Since the JLTV is still undergoing testing evaluation and has yet to be fielded, there are still several characteristics of the JLTV that have yet to be confirmed.

As it has currently been communicated, the JLTV will also come with an integrated diagnostic monitoring system (Feickert, 2018) that will make known any issues to the warfighter. This system will monitor the status of traditional systems in addition to energy storage and power generation system, amongst many others. Table 4 summarizes the specifications the JLTV is currently believed to possess.

Table 4. JLTV specifications. Adapted from “Joint Light Tactical Vehicle” (n.d.).

Engine	Gale Banks Engineering 866T, (V8) 6.6-liter diesel (based on GM Duramax architecture); power output is undisclosed but estimated to be around 300hp)
Transmission	Allison automatic, OSHKOSH transfer case
Suspension	OSHKOSH TAK-4i independent suspension
Range	300 miles
Steering	Power-assisted; front axle

As previously mentioned, the JLTV is slated to come with many different variations, all serving different purposes. While the specifics of each variant and their integrated auxiliary systems are unknown, it is likely that the amount of energy each vehicle requires will be greater than what the Marine Corps’ current tactical vehicles currently consume. Given the expected timeframe for complete integration of the JLTV into the military’s vehicle fleet, the findings of this study provide an opportunity to JLTV developers. With the possible identification of a relatively mature regenerative braking system, there exists the potential to increase the fuel economy and flexibility of the JLTV.

H. THE DOD ACQUISITION SYSTEM

The acquisition of a regenerative braking system for the Marine Corps’ tactical logistics vehicles must be done utilizing and effectively navigating the Department of

Defense Acquisition System. “The Defense Acquisition System exists to manage the Nation’s investments in technologies, programs, and product support necessary to achieve the National Security Strategy and support the United States Armed Forces” (Defense Acquisition University [DAU], 2017, para. 1). The objective of the Defense Acquisition System “is to acquire quality products that satisfy user needs with measurable improvements to mission capability at a fair and reasonable price” (DAU, 2017, para.1). The Defense Acquisition System has a complex architecture capable of fielding several technologies to the DoD simultaneously. This section explains the major milestones in the acquisition system that must be achieved for a regenerative braking system to be fully adopted in the Marine Corps.

This thesis recommends commercial-off-the-shelf (COTS) regenerative braking systems that can be retrofitted onto the current MTRV and the LVSF vehicle platforms with minimal modifications. The first step in the acquisition process for such a system would be to create a Regenerative Braking Integration Program that is vetted by the Joint Capabilities Integration and Development System (JCIDS). The JCIDS “supports the Chairman of the Joint Chiefs of Staff (CJCS) advising the Secretary of Defense in identifying, assessing and prioritizing joint military requirements” (Department of Defense [DoD], 2015, January 23). If a program for regenerative braking is created, an Initial Capabilities Document (ICD) is issued to determine how the program will advance through the Defense Acquisition Management System (DoD, 2015, January 7). The ICD is reviewed by a Milestone Decision Authority (MDA), who makes a Material Development Decision (MDD) to determine at which phase the Regenerative Braking Program will start (DoD, 2015, January 7). The Defense Acquisition Management System has five distinct phases that usher a program of record from its inception to its disposal.

The first phase is the Material Solution Analysis (MSA) phase. Its purpose is to assess the potential material solutions available to meet the requirements of the program (DoD, 2015, January 7). Through an Assessment of Alternatives (AoA), the MSA phase determines if a COTS solution exists or whether a material solution must be developed, based on the Key Performance Parameters (KPPs) outlined in the ICD. This phase

ends once the recommendations for a material solution have been made (DoD, 2015, January 7).

The second phase is the Technology Maturation and Risk Reduction (TMRR) phase. Its purpose is to “reduce technology risk, determine and mature appropriate set of technologies to be integrated into a full system, and to demonstrate Critical Technology Elements on Prototypes” (DoD, 2015, January 7). A milestone “A” brief is conducted to the MDA prior to entering the TMRR phase, which approves the recommended material solutions from the MSA phase and allocates funding for the technology’s development (DoD, 2015, January 7). Contracts are then solicited for competitive prototyping for the program, where the Preliminary Design Review (PDR) evaluates designs submitted by interested candidates (DoD, 2015, January 7). This phase ends once the developed technology has demonstrated, in a relevant working environment, that it is capable of achieving the KPPs identified in the updated ICD, also known as the Capabilities Development Document (CDD) (DoD, 2015, January 7). Prior to conducting the Milestone “B” brief to the MDA to advance to the third phase of the acquisition management system, manufacturing risks must be identified along with means to begin low rate production of the program’s technology (DoD, 2015, January 7).

The third phase is the Engineering and Manufacturing Development (EMD) phase. Its purpose is to “develop a system or increment of capability, develop an affordable manufacturing process, [and] minimize logistics footprint” (DoD, 2015, January 7). There are two distinct sub-phases within EMD that must be satisfied prior to moving forward in the program’s development: 1) Integrated Systems Design; and 2) System Capability and Manufacturing Process Demonstration (DoD, 2015, January 7).

During the Integrated Systems Design portion of EMD, full funding is earmarked in the Future Years Defense Program (FYDP), approved by the Secretary of Defense (DoD, 2015, January 7). A Critical Design Review (CDR) is conducted along with the establishment of a Baseline for Production focused on the program’s hardware, software, human and support systems (DoD, 2015, January 7). This sub-phase ends with the completion of a system-level CDR and a post-CDR assessment, performed by the MDA (DoD, 2015, January 7).

During the System Capabilities and Manufacturing Process Demonstration portion of EMD Developmental Testing (DT) is conducted to assess the progress of the program's development against its technical parameters and an Operational Assessment (OA) against the program's CDD (DoD, 2015, January 7). Key to this sub-phase is the demonstration that the manufacturing process for the program is feasible, reliable, and measurable (DoD, 2015, January 7). This sub-phase ends when the progress of the program is provided to the MDA during the Milestone "C" brief (DoD, 2015, January 7). Acceptance of the Milestone "C" brief allows the Program to move into the Production and Deployment phase.

The fourth phase is the Production and Deployment (P&D) phase. Its purpose is to "achieve an operational capability that satisfies mission needs" (DoD, 2015, January 7). Similar to EMD, P&D has two sub-phases: 1) Low Rate Initial Production (LRIP)/Initial Operational Test and Evaluation (IOT&E); and 2) Full Rate Production and Deployment (FRPD) (DoD, 2015, January 7). LRIP's purpose is to "ensure adequate and efficient manufacturing capability and to produce the minimum quantity necessary to provide production... [for] IOT&E" (DAU, 2010). The interoperability of the program is also evaluated during this sub-phase of P&D; it is possible to reach Initial Operational Capability and introduce the Program to the first units that will employ the system (DoD, 2015, January 7). During the latter sub-phase, FRP&D begins the fielding of the Program's system along with the infrastructure necessary to support the fielded systems (DoD, 2015, January 7). The fielding of a regenerative braking system during the P&D phase will likely consist of the retrofitting of the system on to the MTRV and LVS along with New Equipment Training (NET) for the motor transport community of the Marine Corps to ensure its proper employment and available maintenance support cycle.

The final and longest phase of the Defense Acquisition Management System is the Operations and Support (O&S) phase. Its purpose is to "execute a support program that meets materiel readiness and operational support performance requirements, and sustains the system in the most cost-effective manner over its total life cycle" (DoD, 2015, January 7). During this phase the system is expected to demonstrate its full operational capability (FOC). For a regenerative braking system retrofitted into the

MTVR and LVSR, the O&S phase would be nested into the O&S phase of the existing vehicle platforms, likely as a modification or upgrade to the original system.

Throughout the Defense Acquisition Management System, the maturity of the program is measured in two manners: 1) Technology Readiness Levels (TRL); and 2) Manufacturing Readiness Levels (MRL) (DoD, 2015, January 7). Figure 3 depicts the TRL and MRL levels along with their association with the different phases.

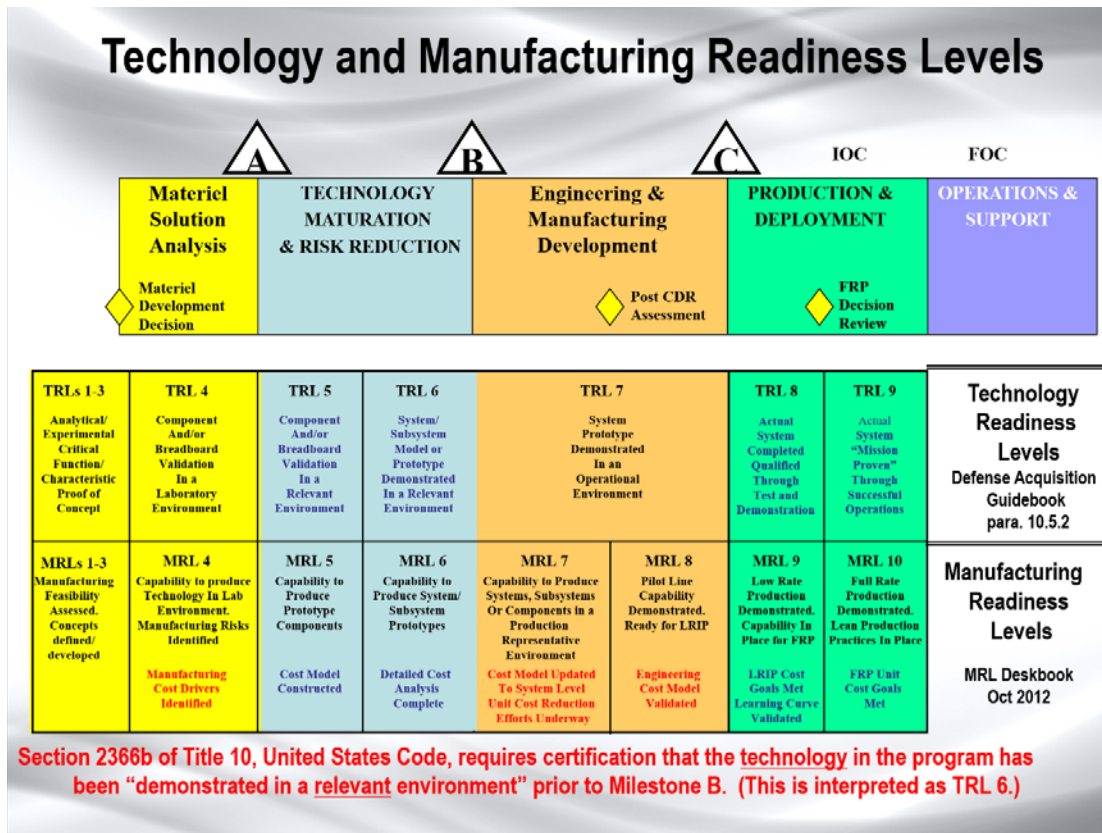

Figure 3. DoD Acquisition System—Levels of Readiness. Source: Office of the Secretary of Defense [OSD] Manufacturing Technology Program (2015).

These TRLs and MRLs can be applied to the increments of a system or to the sub-components of the system. In order for a Program to advance to the next phase however, the system in its entirety must meet the minimum TRL and MRL from the previous phase (DoD, 2015, January 7).

The research for this thesis hypothesizes that a COTS solution exists within the current vehicle industry and it can be retrofitted to the existing MTVR and LVSF vehicle platforms. After a thorough review of the state of the market for COTS options, a regenerative braking system program should be identified that can qualify for the Defense Acquisition System at TRL 6 or 7, the TMRR or EMD phases. On their commercial webpage OSHKOSH Defense, the current manufacturer of the MTVR and LVSF, has alluded to the research and development of renewable energy production for both vehicle platforms, leading to the belief a partial solution for regenerative braking exists (OSHKOSH Defense Inc., 2018). Both the MTVR and the LVSF are in the O&S phase of the Defense Acquisition Management System. The regenerative braking program could be categorized as another increment of each vehicle's program and, as previously mentioned, serve as a modification or update to the existing platforms. This would require the least amount of change to the two vehicle's O&S programs.

1. Depot-Level Maintenance

Inherent in the acquisition system and implementing regenerative braking into tactical vehicles is the role of the Marine Corps' two logistics bases—Marine Corps Logistics Bases (MCLB) Albany and Barstow—would play. These two locations serve as depot-level maintenance centers serving the east and west coast Marine Corps bases, respectively. Depot-level maintenance is one of three, and the highest ranked, level of maintenance conducted in the Marine Corps. Depot-level maintenance entails the “major overhaul and complete rebuilding of parts, subassemblies, assemblies, and end items” (DoN, 1998, p. 1-4). It is likely the adoption of regenerative braking into tactical vehicles would require the work be completed at MCLB Albany and Barstow.

As previously discussed, a common argument against retrofitting for regenerative braking systems is the extensive time and experience it requires. The necessary facilities and equipment also then become a source of concern. These are arguments in which the role provided by MCLB Albany and Barstow provide an answer. All ground equipment is cycled through either of these two locations during their service life, at which point they undergo a complete overhaul (B. Jackson, interview with authors, August 17, 2018).

During this overhaul is a prime opportunity to integrate engineering adjustments—such as idle-reduction or regenerative braking systems—that may be too complex to complete at a lower level of maintenance.

If the integration of regenerative braking is approved and passes the milestones discussed previously, an engineer change proposal (ECP) would be routed (B. Jackson, interview with authors, August 17, 2018). An ECP is the “documentation by which a proposed engineering change is submitted... recommending that a change to an original item of equipment be considered, and the design or engineering change be incorporated” (DoD, 2001, pp. 3-6–3-7). MCLB Barstow and MCLB Albany work through hundreds of ECPs whenever a piece of equipment cycles through their facilities for repair or overhaul (B. Jackson, interview with authors, August 17, 2018). The ECP for integration of a regenerative braking system would become part of the overhaul or repair when the tactical vehicle makes its way to either of these locations.

Figures 4 and 5 display the back of a stripped LVSR, from different angles, staged with cables and wires ready for installation. This is a typical action undertaken at MCLB Barstow and Albany. In fact, these vehicles are broken down and stripped far beyond what is depicted in Figures 4 and 5, which would make the installation of a complex regenerative braking system a simpler ordeal.



Figure 4. View of back of LVSR stripped at MCLB Barstow with cables ready for installation

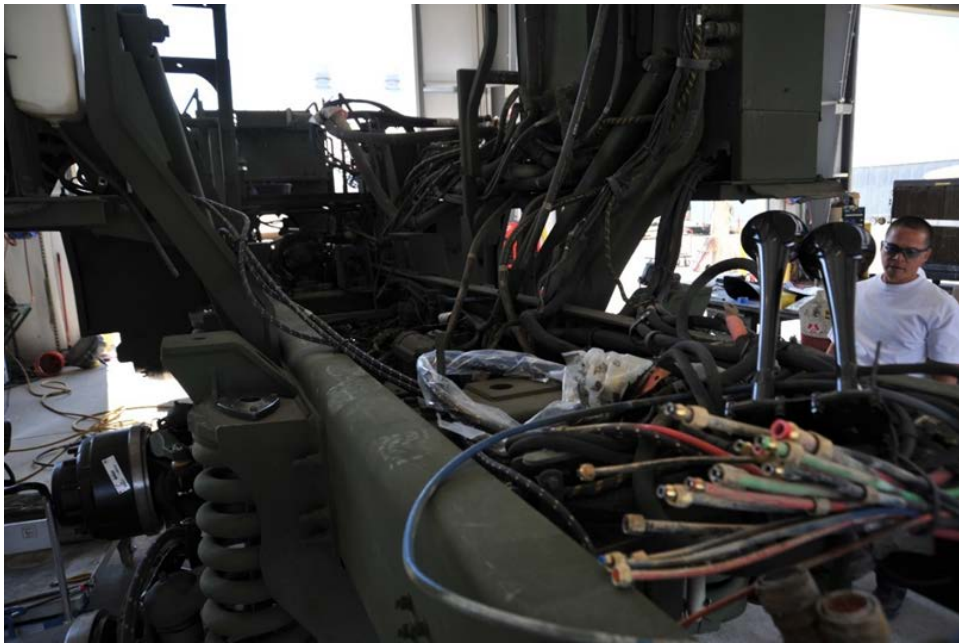

Figure 5. Alternative view of back of stripped LVSR at MCLB Barstow

To provide an idea of how far ground equipment is broken down, Figure 6 provides a visual of two shells of an amphibious assault vehicle (AAV). This action is taken for *every* piece of ground equipment that eventually makes it way through the Depots for overhaul and repair. As a MTRV and LVSR in this stage could not be found at the time, Figure 6 is provided to show an example of how far the break-down process goes.



Figure 6. Completely stripped shells of Amphibious Assault Vehicles (AAV)

III. METHODOLOGY AND RESEARCH APPROACH

A. INTRODUCTION

While commercial regenerative braking systems have relied upon the captured energy to assist in propulsion to reduce fuel costs, this thesis aims to estimate the cost savings by reducing the amount of time service members must idle a vehicle to simply power auxiliary systems. This chapter, therefore, provides the formulas, constants, and factors used in determining the amount of potential energy that might be captured through the typical operation of tactical vehicles. Assumptions and planning factors are expounded upon. These factors also play a role in determining the payback period, or break-even point, of evaluated upgrades. A snapshot of the spreadsheet is included in Appendix A to provide a visual in how the potential energy from the established driving schedule was determined.

The methods and approach used to calculate the energy generated are ultimately incorporated into five different “upgrades” the authors have considered for the purpose of this thesis. Each upgrade is introduced in this chapter with additional baseline assumptions used in the data analysis.

B. FOUNDATIONAL INFORMATION AND ASSUMPTIONS

The data outlined in this section establishes a foundation of information this study utilized to arrive at the amount of energy generated by a tactical vehicle through the act of applying the brakes. This data is necessary to ultimately calculate the amount of potential energy able to be captured, and subsequently the cost, of the considered upgrades. Where concrete data could not be obtained, assumptions were made to best simulate the realities each upgrade might encounter.

1. Environmental Protection Agency (EPA) Driving Schedule

A vehicle’s fuel economy rating is based on its efficiency of burning fuel under particular driving conditions. These conditions are heavily influenced by the amount of braking and follow-on acceleration, in addition to numerous other factors. In 2011,

Kramer and Parker found there was no single driving schedule utilized by the military to determine fuel economy. Instead, there appeared to be six different schedules, broken down into two broad categories: time dependent speed profiles, provided by the EPA; and distance dependent grade profiles, determined by the U.S. Army (Kramer & Parker, 2011). Given the age of this report, a more recent driving schedule established by the EPA in 2018 was used for this analysis.

The selected driving schedule establishes the foundation for determining the amount of potential energy available and ultimately, the results of this thesis. The amount and length of accelerating and decelerating determine what energy is capable of being captured. This particular driving schedule, displayed by Figure 7, was selected because it is the same schedule utilized to calculate the fuel economy of heavy-duty vehicles by the EPA, which our tactical vehicles would be categorized as.

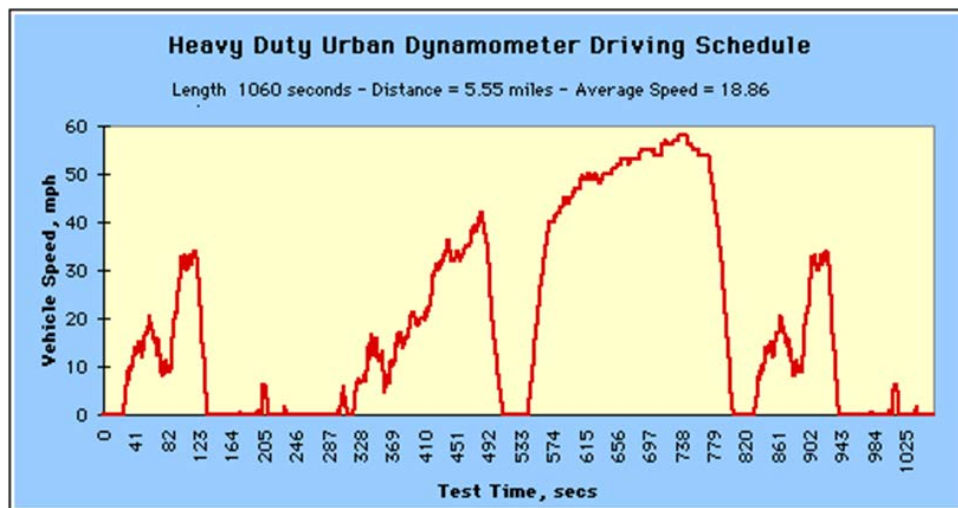

Figure 7. Analysis driving schedule. Source: Environmental Protection Agency [EPA] (2018).

2. General Mathematical Constants, Conversions, and Formulas

a. Adjustment of Driving Schedule

The selected driving schedule is a 1,060 second profile, or roughly 18 minutes. During this time, a vehicle’s speed is tracked in miles per hour (mph), ranging from 0–

60 mph. Both measurements were adjusted and converted for the purpose of this study. The driving profile was made to be one hour long (60 minutes), and the EPA schedule, therefore, was repeated 3.4 times over. This multiplication factor was also applied to the distance covered; in an hour, the distance a vehicle travels in this particular driving schedule is 18.85 miles (5.55 miles * 3.4). This hour-long profile is also considered a theoretical training day in this analysis. Lastly, the vehicle's speed was converted from miles per hour to meters per second by applying the appropriate constant.

b. Constants and Formulas

The amount of energy generated from a particular drive schedule is not only dependent on a vehicle's period of acceleration and deceleration. A vehicle's mass and weight, along with its aerodynamics, also play a significant role. There are also parasitic losses that must be accounted for, such as wind drag. This section outlines these factors which ultimately drove how much energy was generated during this analysis' hour-long driving schedule.

- Velocity conversion factor (mph to m/s): 0.44704 (Quora, 2018).
- Mass (MTVR): 28,239 kg
- Mass (LVSR): 69,260 kg
- Weight (MTVR): $277,024.6 \text{ kg} \cdot \text{m/s}^2$
- Weight (LVSR): $679,440.6 \text{ kg} \cdot \text{m/s}^2$
- Weight = mass * earth's gravitational constant (Study.com, 2018)
- Gravitational constant: 9.81 m/s^2
- Rolling Resistance Force (MTVR): $5,540.491 \text{ kg} \cdot \text{m/s}^2$
- Rolling Resistance Force (LVSR): $13,588.81 \text{ kg} \cdot \text{m/s}^2$
- Rolling Resistant Force = Vehicle Weight * Rolling Resistant coefficient for gravel (Wong, 1993)

- Rolling Resistance coefficient, gravel = 0.02
- Frontal Area (MTVR): 8.93163 m²
- Frontal Area (LVSR): 8.791194 m²
- Air density: 1.2 kg/m³ (Engineers Edge, 2018)
- Coefficient of Drag: 0.76 (White, Table 7.3, p. 491, 2010)

These constants are applied at different points to determine appropriate values for the desired measurements provided in Table 5. While the MTVR's and LVSR's large mass and weight are advantageous in generating energy, their size and shape generate larger forces of resistance. An assumption for the type of rolling resistance force was utilized in this analysis, pursuing the constant associated with travel on gravel surfaces. Although our tactical vehicles do travel on paved roads, a significant portion of their operation is on dirt and gravel roadways. This occurs in both a training and deployed environment. The rolling resistance coefficient for gravel also enables a more conservative estimate.

Table 5. Formulas used to determine maximum potential energy generated

Column	Measurement	Formula	Citation
F	[Ideal] Potential Energy (E)	$0.5 * \text{mass} * \text{velocity}^2$	The Physics Classroom, 2018
N	Rolling Resistance Power (J/s)	Velocity * Rolling Resistance Force	Wong, 1993
R	Drag Force (N)	Coeff. Of Drag * 0.5 * Air Density * velocity ² * frontal area	NASA, 2018
S	Drag Power (J/s)	Drag Force * velocity	Bedford & Fowler, 2004

The periods of deceleration, or braking, were extrapolated from the driving schedule. With the application of the respective vehicle's mass, weight, speed, and appropriate factors of resistance, the total amount of potentially usable energy was found,

measured in joules. From this number, the maximum number of amp-hours could be calculated. Although the amount of energy generated could be quite high, there are several limiting factors which reduce the amount of *usable* energy. These factors are explained as the upgrades in which they present themselves are addressed.

3. Basic Vehicle Operation

The daily operation of the vehicle is assumed to be similar to that displayed by Figure 7 for a time period of 60 minutes (distance of 18.85 miles). After this time, or “training day,” it is assumed the vehicle will have arrived at its destination and then proceed to idle to operate the auxiliary systems.

Based on the authors’ experience as Marine Officers who were intimately involved in convoy operations, fuel distribution, and logistical planning, the amount of time a tactical logistic vehicle spends driving and idling varies greatly. Numerous factors are at play, including operational tempo of the battalion/unit, mission of the battalion/unit, variant of the MTRV and LVSR utilized and its particular tasking, and even the maintenance readiness of the vehicle. This analysis assumes a MTRV and LVSR each operate 200 training days in a single calendar year and idle on average six hours a day for each training day.

4. Fuel Cost and Consumption while Idling

The Defense Logistics Agency has been named “the nation’s combat logistics support agency” and is officially tasked with “[managing] the global supply chain—from raw materials to end user to disposition—for the Army, Navy, Air Force, Marine Corps, Coast Guard, 10 combatant commands, other federal agencies, and partner and allied nations” (DLA, n.d.). As of 01 April 2018, DLA lists the cost of JP-8 at \$2.76 per gallon (DLA, n.d.). Given the wide variety of factors and associated prices of determining the cost of a gallon of fuel in a deployed environment, \$18 is established for this analysis (Larson & Whitt, 2013). This price was found to be the average “fully burdened” price of a gallon of fuel during a study conducted in 2013 (Larson & Whitt) and was recommended for future analyses.

While there are wide-ranging differences between a training environment and a deployed one, for the purpose of this analysis the primary difference will be the cost of a gallon of JP-8 fuel. Henceforth, calculations for a training, garrison, or stateside environment will be referred to as “CONUS” and utilize the \$2.76 price tag. Calculations utilizing the larger \$18 price are in reference to a deployed, or “OCONUS,” environment.

The amount of fuel consumed during a vehicle’s idling varies on the revolutions per minute (rpm) the engine is maintained at. During an investigation in an attempt to reduce idling in the commercial trucking industry, NACFE calculated trucks burn anywhere from 0.5 gallons to 1.5 gallons per hour of idling (NACFE, 2014). When comparing the idling rpm rate of the MTVR and LVSR with the semi-trucks analyzed by NACFE, and to follow a more conservative route, a burn rate of 0.5 gallons per hour was utilized in this analysis. These data points establish the assumption that for every hour a MTVR and LVSR does not idle their engine, there exists a cost savings of \$1.38. A summary of the assumed and actual input parameters used to determine fuel and other cost-savings are in Tables 6 and 7.

Table 6. MTVR parameters utilized for calculations

Operations Input Parameters (MTVR)	
Avg Hours Vehicle Idles in a Single Training Day	6
Avg Number of Training Days per Year	200
MPG of Vehicle	3.8
Avg Vehicle Range (Miles)	304.0
Gallons Required to Idle Engine for an Hour	0.5
Size of Gas Tank (gal)	80
CONUS FY18 Cost of JP-8 per Gal	\$2.76
Cost of Full Tank of Fuel (CONUS)	\$220.80
OCONUS Cost of JP-8 per Gal	\$18.00
Cost of Full Tank of Fuel (OCONUS)	\$1,440.00

Table 7. LVSR Parameters utilized for calculations

Operations Input Parameters (LVSR)	
Avg Hours Vehicle Idles in a Single Training Day	6
Avg Number of Training Days per Year	200
MPG of Vehicle	2.0
Avg Vehicle Range (Miles)	332.0
Gallons Required to Idle Engine for an Hour	0.5
Size of Gas Tank (gal)	166
CONUS FY18 Cost of JP-8 per Gal	\$2.76
Cost of Full Tank of Fuel (CONUS)	\$458.16
OCONUS Cost of JP-8 per Gal	\$18.00
Cost of Full Tank of Fuel (OCONUS)	\$2,988.00

5. Cost of Labor

The Marine Corps has two locations on which it relies for depot level maintenance. Marine Corps Logistics Base Barstow (MCLB-Barstow) is the Corps' location in the west coast; and MCLB-Albany the east coast location for depot level maintenance. The majority of the upgrades discussed in this study would be completed at either of these two locations. The labor rates for Barstow, however, were selected for this analysis.

The operations office of MCLB-Barstow provided various labor hour rates (specifically, 13) for the range of different tasks their engineering department accomplishes. These values range from \$59.56–\$112.88 per hour (Gilmer, 2018), with an average rate of \$76.96 across the 13 different task categories. This average value was the labor rate applied in this analysis.

It is important to be aware of the work completed at Barstow and Albany. It is recognized by the authors that installing regenerative braking requires a high level of expertise, a significant amount of time, and can require the significant breakdown of a vehicle. These are all considerations and requirements already accounted for at both locations. The work accomplished at Barstow and Albany provide a unique environment in which the incorporation of a regenerative braking system would be feasible given the site capabilities (B. Jackson, interview with authors, August 17, 2018). Figures 8–12

provide a visual of a tactical vehicle's axles and how feasible it would be to install a regenerative braking system during the course of a vehicle's overhaul at either MCLB Barstow or Albany.



Figure 8. View of MTVR wheel axle



Figure 9. View of MTVR wheel axle and suspension



Figure 10. Side view of MTVR rear wheel axle and strut



Figure 11. View of Cougar axles mounted to V-shaped hull



Figure 12. Close-up view of Cougar wheel axle

6. Solar Irradiance

When determining the amount of potential energy captured from the sun's rays for use in electrical systems, solar irradiance is the driving factor. Irradiance is "the amount of light energy from one thing hitting a square meter of another each second" (National Aeronautics and Space Administration [NASA], 2008). Solar irradiance, therefore, is how much energy the sun radiates to the Earth's surface. As such, the amount of solar irradiance depends on the location of the earth's surface from which the energy is measured. For example, the solar irradiance measured along the earth's equator will be greater than that measured at either of the poles.

This analysis also explores the potential energy available through the sun's radiant energy. This radiant energy is described as Solar Irradiance and is measured by the amount of total daylight the sun provides in a 24-hour period (National Renewable Energy Laboratory [NREL], 2017). This value determines the amount of radiant energy available to the solar panels.

When determining the amount of potential energy captured from the sun's rays, the solar irradiance of Camp Pendleton, California, is utilized. This location provides a yearly average of 5.68 hours of usable sunlight per day (NREL, 2017). This value drives the amount of radiant energy available to the solar panels that could potentially be installed.

C. GENERAL MTRV AND LVSR CONSIDERATIONS

The MTRV and LVSR are equipped with the same model starter batteries. These sealed lead acid batteries are manufactured by a Hawker company and are known as the Armasafe Plus 6TAGM (Absorbed Glass Mat) (Hawker, 2010). The batteries are rated for 120 AmpHrs, at 12 VDC but are installed in parallel to achieve compatibility with the 24 VDC systems (DoN, 2015, December) of both the MTRV and LVSR. The MTRV is typically equipped with two of these batteries while the LVSR requires four.

1. Alternator Types and Efficiencies for the MTRV and LVSR

The MTRV is equipped with a 300 Ampere alternator (DoN, 2015, December), while the LVSR's alternator is rated for 400 Amperes (DoN, 2015, September). The average alternator has an efficiency rating of 21% when converting mechanical energy from a gallon of fuel to electrical energy (NACFE, 2017). This efficiency factor was applied to the MTRV's and LVSR's alternators to determine the amount of fuel each alternator required to either provide power to the vehicle's auxiliary systems or, to charge an auxiliary power unit.

When calculating the amount of energy the alternator is relieved from producing by virtue of the different upgrades, it will be assumed only 80% of the battery pack's stored energy will be factored into the calculation. This is a typical safety measure (undertaken by the BMS) to avoid damaging or completely discharging the battery pack.

2. Energy Demand of Auxiliary Systems

While the type and number of auxiliary systems aboard our tactical vehicles vary greatly, along with expected energy draw, this analysis accounts for only one: the vehicle's communication suite—the VRC-113. While not currently installed in every

MTVR or LVSR in the fleet, it is assumed they eventually will be given the increased desire for communication ability in all fleet vehicles.

This study's analysis assumes the VRC-113, on average, levies a 15 AmpHr draw on a vehicle's battery system (C. Krueger, interview with authors, August 17, 2018). With no modifications, the MTVR's and LVSR's starter batteries are capable of supplying a baseline 16 and 32 hours, respectively, of non-idling to the vehicle's operator while powering the VRC-113. Since the starter batteries currently installed on the vehicles is already capable of powering auxiliary units within the pre-established training day (i.e., six hours of idling), regenerative braking systems would primarily serve as an additional source of propulsion. Therefore, the amount of energy generated will be calculated in terms of the kilowatts the upgrade relieves the alternator from producing.

3. Service Life Expectancy of the MTVR and LVSR

During a panel discussion at the 15th Annual Acquisition Research Symposium in Monterey, California, the former United States Assistant Secretary of the Army for Acquisition, Logistics, and Technology, Katrina McFarland, stated the best-case scenario for the development, acquisition, and full introduction into the fleet of a new combat vehicle can take up to forty years. This is the current expectation for the full fielding of the JLTV. From this statement, the authors assume that, even though the MTVR's and LVSR's predecessors had an average service life of only 21.5 years, the DoD's current fiscal environment requires twice that from its current models. This study assumes a remaining service life of 20 years, commencing in 2021 and therefore ending in 2041, for both the MTVR and LVSR.

D. OVERVIEW OF UPGRADE OPTIONS

This chapter focuses on five theoretical upgrades the MTVR and LVSR could undergo that would potentially result in positive returns on investment within a matter of years from initial installation. All components considered as part of the upgrades are available on the commercial vehicle market (commercial-off-the-shelf [COTS]) and would require minimal modifications to their current design to properly equip the Marine Corps' two primary logistic vehicles.

While the primary focus of this thesis is to explore the efficacy of regenerative braking, additional means to power auxiliary systems and/or reduce fuel costs was also analyzed. These efforts included installing anti-idling components and mounting flexible solar panels. The addition of solar panels was analyzed because of its rapidly decreasing costs; such a decrease has led to on-truck systems available in the commercial market. It therefore makes sense to compare this alternative to the regenerative braking options in order to ascertain which alternatives are most attractive for the USMC.

A list of the upgrades analyzed as part of this thesis are:

- Upgrade 1: anti-idling device + supercapacitor (emergency override)
- Upgrade 2: drivetrain regenerative braking system + APU
- Upgrade 3: in-wheel regenerative braking systems + APU
- Upgrade 4: improved battery system
- Upgrade 5: flexible solar array

1. Upgrade 1—Anti-Idling Device, Supercapacitor, and Emergency Override

Upgrade 1 focuses solely on saving fuel cost through limiting the amount of time a vehicle’s engine is permitted to idle during operation. No components in this upgrade seek to capture any renewable energy created by the vehicle’s normal operations.

The installation of the anti-idling device would restrict the vehicle’s engine from idling beyond a predetermined time, requiring the vehicle operator to power any of the vehicle’s auxiliary systems through its existing starter battery pack when the engine is shutdown. The supercapacitor would serve as an electrical fail-safe in the event the vehicle operator exhausts all the batteries’ power but needs to restart the engine due to mission necessity. The emergency override system would allow the vehicle operator to disable the anti-idling device if the mission deemed the automatic shutdown of the engine too burdensome to mission accomplishment. As depicted by Figure 13, this upgrade is relatively simple, and the supercapacitor would be a “drop-in” component.



Figure 13. Visual of drop-in capacitor battery from Maxwell.
Source: Amazon.com (2018).

2. Upgrade 2—Drivetrain Regenerative Braking System with an Auxiliary Power Unit (APU)

Upgrade 2 explores the concept of installing and integrating a regenerative braking system into the vehicle's drivetrain. An example of such a system is depicted by Figure 14, which appears similar in appearance to the engine block of an internal combustion engine.

The drivetrain regenerative braking system utilized for calculations in this analysis is manufactured by the company InMotion and advertises a 93% efficiency in capturing energy at maximum rate of 40,000 watts (InMotion, 2018). This efficiency would typically be dampened by the efficiency of the vehicle's torque converter and, for this study, the average efficiency of 80% (J&M Clutch and Converter, 2018) was applied. This results in an overall system efficiency of 74.4% ($0.90 * 0.80 = 0.744$).

The ability to capture up to 40,000 joules per second during the established driving schedule equates to 811.22 Ah. The amount of energy *actually* stored, however, is further limited by the amount of current the vehicle's batteries and/or are capable of

receiving. The APU for both the MTVR and LVSR would be made up of four Navitas Systems Lithium 6T batteries, rated at 99 AmpHrs each with a maximum current of 180 amperes (Navitas Systems, 2018). The APU would be set up in parallel so it would be capable of accepting up to 17,280 joules per second within a 24 VDC system. An internal resistance of 5% is applied to the overall potential energy inputted to the APU (Battery University, 2018).



H 40 EP and H 50 EP Drive Unit

Figure 14. Allison regenerative drivetrain transmission.
Source: Allison Transmission (2016).

3. Upgrade 3—In-wheel Regenerative Braking System with an Auxiliary Power Unit (APU)

Upgrade 3 capitalizes on the same potential energy Upgrade 2 aims to capture however, the regenerative braking mechanism is to be installed within the hub of a select number of wheels on the vehicle. Figure 15 provides a visual break-down of such a system and how it might be integrated into the wheel hub of a vehicle.



Figure 15. Regenerative braking system applied to vehicle wheel. Source: Kane (2018).

In addition to the potential energy calculations outlined, the in-wheel regenerative braking system must account for revolutions per minute and the torque found at each wheel. These values are found utilizing the diameter of the vehicle’s tire, the angle velocity of the wheel, and the number of wheels the system is installed within. These particular measurements and the formulas necessary to determine their values are outlined in Table 8.

Table 8. Formulas for determining in-wheel energy capture

Measurement	Formula	Citation
Angle Velocity	$(\text{Velocity} * \text{tire diameter}) / 2$	Borgnakke and Sonntag, 2012, p. 134
Wheel rpm	$(\text{angle velocity} * 60) / (2 * \pi)$	
Available Torque	$(\Delta \text{ Energy with Drag} / \# \text{ of Vehicle Wheels}) / \text{Angle Velocity}$	
Max Power with Limited Torque	$\text{Usable Torque} * \text{Angle Velocity}$	
Tire diameter = 1.34m (constant) (DoN, 2015, December and DoN, 2015, September)		

Similar to Upgrade 2, the in-wheel regenerative braking system must account for the efficiency of the system, which is rated for approximately 70% and 80,000 watts however, because the torque converter of the vehicle is upstream from the braking system, it will not dampen the energy captured.

The maximum amount of potential energy capturable at each wheel is multiplied by the number of wheels the system will be installed within. Upgrade 3 provides the following options for each vehicle type:

- MTVR(a): Two In-Wheel Regenerative Braking Systems
- MTVR(b): Four In-Wheel Regenerative Braking Systems
- LVSR(a): Four In-Wheel Regenerative Braking Systems
- LVSR(b): Six In-Wheel Regenerative Braking Systems.

The APU for both the MTVR and LVSR would be the same utilized in Upgrade 2: four Navitas Lithium 6T batteries set up in parallel.

4. Upgrade 4—Improved Starter Batteries

The biggest inhibitor of the Armasafe Plus 6ATGM batteries currently utilized in tactical vehicles is their 5-ampere (120 joules/sec) maximum allowable current (on a 24 VDC system), which results in slow recharging times from the vehicle's existing alternator (Hawker, 2010). Upgrade 4 focuses on reducing the required recharging time of the starter battery pack of the MTVR and LVSR while still delivering similar levels of available amp-hours to operate the vehicles' auxiliary systems. Upgrade 4 replaces the existing Armasafe 6TAGM batteries with the Navistas Lithium Ion 6T batteries rated at 99 AmpHrs each (Navitas Systems, 2018); two for the MTVR and four for the LVSR.

The alternator has an efficiency rating of 21% to convert the potential energy in a gallon of JP-8 from mechanical to electrical energy (NACFE, 2017). The conversion for energy of a gallon of diesel is 40.3 kWh (Cannon, 2017, para. 12). In one hour, the alternator requires 34.3kWh, or roughly 0.85 gallons of JP-8, to fully charge the starter

battery suite. This results in a cost of \$1.50 (given the DLA price tag of \$2.76 per gallon of JP-8) to charge the starter battery suite while the MTVR is driving.

5. Upgrade 5—Flexible Solar Array

Upgrade 5 leverages the solar power captured during the day to alleviate the electrical demand on the vehicle’s alternator during transit. Flexible solar arrays are available COTS and are starting to be adopted by commercial long-haul trucking companies around the United States (NACFE, 2018), as depicted by Figure 16. The flexible solar array system used for planning and calculations is from Bergstrom, a company that specializes in climate control units for sleeper cabs of semi-trucks. Bergstrom’s flexible solar arrays come in multiple configurations with varying wattage ratings to best suit the vehicle’s electrical demand (Bergstrom, 2018). This upgrade strictly explores the potential benefits of Bergstrom’s largest solar array available, the 440 Watts, 2 x 220W 12 VDC Solar Kit (Bergstrom, 2018).



Figure 16. Flexible solar array applied to roof of commercial truck

Since the assumed solar irradiance (of Camp Pendleton, CA) of 5.68 hours is based on a total exposure time of 12 hours, the rate must be divided in half since the assumed training day is six hours of idling. Therefore, 2.84 hours of sunlight multiplied by the 440 wattage rating of the panels yields 1.232 kWhrs in a single 24-hour period training at Camp Pendleton while assuming we are only training for 6 hours. This equates to approximately 51.33 AmpHrs per day when converted to a 24 VDC system (see formula below).

$$\text{Potential Energy (kWh)} = \text{Hrs sunlight} * \text{wattage rating (EnergySage, 2018)}$$

IV. DATA ANALYSIS

A. INTRODUCTION

This chapter summarizes the findings from the calculations outlined in Chapter III while also assigning a dollar value to those findings. The discussion of each particular upgrade explores the theoretical potential energy each system can provide and thus the amount of engine idle time that can be avoided. These numbers contribute to the value of fuel saved, the estimated installation cost for each upgrade, the break-even point for the upgrade's installation, and the total cost savings of the upgrade over the remaining lifecycle of each vehicle.

1. Break-Even Point

Intuitively, the break-even point is measured in how much time it takes to recoup the cost of the upgrade via the amount of fuel saved by virtue of the upgrade. The break-even point is measured in years, with one exception. Given its relatively low price coupled with the price tag of \$18 (Larson & Whitt, 2013) for a gallon of fuel in a deployed, or OCONUS, environment, Upgrade 1 is the only option in which the break-even point in a deployed environment is less than a year. It is therefore, measured in days. All other upgrade options have a payback period, or break-even point, measured in years (in both environments).

2. Yearly Savings and Net Present Value

Yearly savings was calculated by multiplying the number of non-idling hours each upgrade can provide in a 24-hour period with the cost of a gallon of fuel (\$2.76 for training environment (CONUS) and \$18 for deployed (OCONUS) environment) and the number of training days the vehicle is expected to be operated each year. A planning factor of 200 training days for each year was utilized for this analysis. A consolidated view of the findings for the MTRV and LVSR are in Tables 27 (p. 82) and 28 (p. 83), respectively, in Chapter V.

Net present value (NPV) was only calculated for the upgrade option that “won,” or proved to be the most cost-effective. In this case, Upgrade 1 proved to be the winner. The NPV was calculated for both a CONUS and OCONUS environment, with the differentiating factor being the price of a gallon of fuel. The NPV is calculated over the entirety of the expected 20-year service life of both vehicles, installed in 2020 with yearly savings being realized in 2021. This discount value is 2.5% and is determined by the OMB (Donovan, 2016). The spreadsheet depicting the NPV calculations are included at the end of this chapter. Table 25 provides the NPV for a CONUS environment, while Table 26 provides an OCONUS NPV. All calculations and dollar values are in CY18 dollars.

B. UPGRADE 1: ANTI-IDLING DEVICE, SUPERCAPACITOR, EMERGENCY OVERRIDE

Upgrade 1 is the second-cheapest option, calculated at **\$1,760.76** (procurement and installation), with a break-down according to components and labor provided in Table 9.

Table 9. Cost break-down of Upgrade 1

Acquisition Input Parameters	
Anti-idling System w/Override (Flight Systems Inc., 2018)	\$350.00
Super Capacitor	\$949.00
Avg Cost of Labor Man-Hour-MCLB Barstow	\$76.96
Total Man-hours for Equipment Installation	6
Total Labor Cost for Installation-MCLB Barstow	\$461.76
Total Cost of Upgrade	\$1,760.76

Given the returns in terms of fuel saved, Upgrade 1 would result in positive returns the earliest (i.e., lowest break-even point). In a CONUS environment, returns would begin just slightly after a year (see Table 11), while in an OCONUS environment, returns would be realized after just 33 days (see Table 12). Upgrade 1 would result in 38% cost savings for the MTVR and 24% for the LVSR, as displayed in Table 10.

Table 10. Upgrade 1 returns

Returns		
	<u>MTVR</u>	<u>LVSR</u>
Fuel Required for Driving Profile	4.96	9.43
Fuel used during Idling (6 hours)	3	3
Total Fuel used in a Single Training Day (gal)	7.96	12.43
Percent Savings Due to Anti-Idling	38%	24%

Table 11. Break-down of payback period for Upgrade 1 in CONUS environment

Estimated Time Required for Payback of Upgrade (CONUS)	
	<u>MTVR & LVSR</u>
Savings of Fuel (in an Hour) for not Idling the Engine	\$1.38
Total Cost of Upgrade	\$1,760.76
Hours of Non-Idling Required to Recoup Cost	1,275.91
Avg Hours Vehicle Idles in a Single Training Day	6
Payback period for Upgrade (Yrs)	1.06
Total Savings per Year after Upgrade	\$1,656.00

Table 12. Break-down of payback period for Upgrade 1 in OCONUS environment

Estimated Time Required for Payback of Upgrade (OCONUS)	
	<u>MTVR & LVSR</u>
Savings of Fuel (in an Hour) for not Idling the Engine	\$9.00
Total Cost of Upgrade	\$1,760.76
Hours of Non-Idling Required to Recoup Cost	195.64
Avg Hours Vehicle Idles in a Single Day	6
Payback period for Upgrade (days)	32.61
Total Savings per Year after Upgrade	\$10,800.00

C. UPGRADE 2: DRIVETRAIN REGENERATIVE BRAKING SYSTEM WITH AUXILIARY POWER UNIT

Upgrade 2’s estimated cost for acquisition and installation is **\$9,438.16**, with the break-down of this value provided in Table 13.

Table 13. Cost break-down of Upgrade 2

Acquisition Input Parameters	
Renewable-Energy Unit Cost (RG Drive Train)	\$2,300.00
Cost of Labor Man-Hour-MCLB Barstow	\$76.96
Total Man-hours for Equipment Installation	46
Total Labor Cost for Installation	\$3,540.16
Cost Per APU Battery (6T Li Batt 24V DC)	\$899.50
Number of batteries per System	4
Cost of Renewable-Energy Suite	
w/6T Li Batt 24V DC	\$9,438.16

Given the efficiency of the drivetrain and components, Upgrade 2 is only able to capture a portion of the potential energy generated during the driving schedule. This is a limitation experienced by a majority of regenerative braking systems. The energy that is able to be effectively harnessed for Upgrade 2 is displayed in Tables 14 and 15, along with associated cost savings and percentage of fuel saved.

Since only a portion of the energy generated from the driving schedule was able to be effectively captured, only a small amount of fuel is saved in a single training day—0.648 gallons for the MTVR and 0.652 for the LVSR. As such, the payback period of the drivetrain regenerative braking system in a CONUS environment is just over 26 years for both vehicles, which is displayed in Table 16. Table 17 outlines the payback period in an OCOUNS environment, which is just over four years for both vehicles.

Table 14. Returns to MTRV from Upgrade 2

Energy & Cost Returns – MTRV	
Energy Captured in 1 hour of Driving	373.88 Ah
Energy alternator is relieved of producing due to Upgrade	8.97 kW
Captured Energy Available to Propel Vehicle	7.83 kW
Energy Saved by Upgrade Propelling the Vehicle	26.11 kW
Fuel Saved by Upgrade Propelling the Vehicle	0.648 gal
Cost Avoided in Single Training Day by Upgrade	
	CONUS \$ 1.79
Marginal Yearly Savings generated by Upgrade	
	CONUS \$ 357.66
Cost Avoided in Single Training Day by Upgrade	
	OCONUS \$ 11.66
Marginal Yearly Savings generated by Upgrade	
	OCONUS \$ 2,332.57
	Fuel Savings 13%

Table 15. Returns to LVSR from Upgrade 2

Energy & Cost Returns – LVSR	
Energy Captured in 1 hour of Driving	376.20 Ah
Energy alternator is relieved of producing due to Upgrade	9.03 kW
Captured Energy Available to Propel Vehicle	7.88 kW
Energy Saved by Upgrade Propelling the Vehicle	26.27 kW
Fuel Saved by Upgrade Propelling the Vehicle	0.652 gal
Cost Avoided in Single Training Day by Upgrade	
	CONUS \$ 1.80
Marginal Yearly Savings generated by Upgrade	
	CONUS \$ 359.88
Cost Avoided in Single Training Day by Upgrade	
	OCONUS \$ 11.74
Marginal Yearly Savings generated by Upgrade	
	OCONUS \$ 2,347.04
	Fuel Savings 7%

Table 16. Break-down of payback period for Upgrade 2 in CONUS Environment

Estimated Time Required for Payback of Upgrade (CONUS)		
	<u>MTVR</u>	<u>LVSr</u>
Savings of Fuel from Upgrade Propelling the Vehicle per Yr	\$357.66	\$359.88
Cost of Upgrade	\$9,438.16	\$9,438.16
Payback Period (Years)	26.39	26.23

Table 17. Break-down of payback period for Upgrade 2 in OCONUS Environment

Estimated Time Required for Payback of Upgrade (OCONUS)		
	<u>MTVR</u>	<u>LVSr</u>
Savings of Fuel from Upgrade Propelling the Vehicle per Yr	\$2,332.57	\$2,347.04
Cost of Upgrade	\$9,438.16	\$9,438.16
Payback Period (Years)	4.05	4.02

D. UPGRADE 3: IN-WHEEL REGENERATIVE BRAKING SYSTEM WITH AUXILIARY POWER UNIT

The results for Upgrade 3 are dependent on the *number of wheels*, or hubs, the in-wheel system is installed into. To provide a greater range, two different estimates for both the MTVR and LVSr are provided. “MTVR (a)” and “MTVR (b)” indicate the system installed on two and four wheels, respectively. “LVSr (a)” and “LVSr (b)” therefore, indicate the system installed on four and six wheels, respectively. Tables 18–22 break out the calculations for Upgrade 3.

The estimated acquisition and installation cost are as follows: MTVR (a): **\$9.630.32**; MVTR (b) and LVSr (a): **\$14,893.04**; and LVSr (b): **\$20.155.76**.

Similar to Upgrade 2, Upgrade 3 is relatively inefficient, offering little ability to reduce fuel consumption. Even in the best-case scenario for Upgrade 3 (system installed on two wheels of a MTVR), the payback period in a CONUS environment is more than

twice the expected remaining service life of each of the vehicles (i.e., more than 40 years). In an OCONUS environment, the average payback period (across all four options) is over seven years. The MTRV is calculated to experience a 10% average savings of fuel, while the LVSR is expected to realize a 6–7% improvement.

Table 18. Cost break-down of Upgrade 3

Acquisition Input Parameters	MTRV	LVSR
Renewable-Energy Unit Cost (RG In Wheel)	\$1,400.00	\$1,400.00
Number of In Wheel Motors Installed		
3(a)	2	4
3(b)	4	6
Cost of Labor Man-Hour-MCLB Barstow	\$76.96	\$76.96
Total Man-hours for Equipment Installation		
Hours per Wheel/Motor	8	8
Hours per APU	5	5
Number of Laborers	2	2
Total Labor Cost for Installation		
3(a)	\$3,232.32	\$5,695.04
3(b)	\$5,695.04	\$8,157.76
Cost Per APU Battery (6T Li Batt 24V DC)	\$899.50	\$899.50
Number of Batteries	4	4
Cost of Renewable-Energy Suite		
3(a)	\$9,630.32	\$14,893.04
3(b)	\$14,893.04	\$20,155.76

Table 19. Returns to MTRV from Upgrade 3

Energy & Cost Returns – MTRV		
	3(a)	3(b)
Energy Captured in 1 hour of Driving	247.78 Ah	326.44 Ah
Energy alternator is relieved of producing due to Upgrade	5.95 kW	7.83 kW
Captured Energy Available to Propel Vehicle	5.19 kW	6.84 kW
Energy Saved by Upgrade Propelling the Vehicle	17.30 kW	22.80 kW
Fuel Saved by Upgrade Propelling the Vehicle	0.429 gal	0.566 gal
Cost Avoided in Single Training Day by Upgrade		
CONUS	\$ 1.19	\$ 1.56
Average Number of Training Days per Year		
CONUS	200	200
Marginal Yearly Savings generated by Upgrade		
CONUS	\$ 237.03	\$ 312.28
Cost Avoided in Single Training Day by Upgrade		
OCONUS	\$ 7.73	\$ 10.18
Marginal Yearly Savings generated by Upgrade		
OCONUS	\$ 1,545.85	\$ 2,036.59
Fuel Savings	9%	11%

Table 20. Returns to LVSR from Upgrade 3

Energy & Cost Returns – LVSR		
	3(a)	3(b)
Energy Captured in 1 hour of Driving	343.45 Ah	368.62 Ah
Energy alternator is relieved of producing due to Upgrade	8.24 kW	8.85 kW
Captured Energy Available to Propel Vehicle	7.20 kW	7.72 kW
Energy Saved by Upgrade Propelling the Vehicle	23.99 kW	25.74 kW
Fuel Saved by Upgrade Propelling the Vehicle	0.595 gal	0.639 gal
Cost Avoided in Single Training Day by Upgrade		
CONUS	\$1.64	\$1.76
Marginal Yearly Savings generated by Upgrade		
CONUS	\$328.55	\$352.63
Cost Avoided in Single Training Day by Upgrade		
OCONUS	\$10.71	\$11.50
Marginal Yearly Savings generated by Upgrade		
OCONUS	\$2,142.70	\$2,299.74
Fuel Savings	6%	7%

Table 21. Break-down of payback for Upgrade 3 in training environment

Estimated Time Required for Payback of Upgrade (CONUS)				
	<u>MTVR</u>		<u>LVSR</u>	
	<u>2</u>	<u>4</u>	<u>4</u>	<u>6</u>
Number of In Wheel Motors Installed				
Savings of Fuel from Upgrade Propelling the Vehicle per Yr	\$237.03	\$312.28	\$328.55	\$352.63
Cost of Upgrade	\$9,630.32	\$14,893.04	\$14,893.04	\$20,155.76
Payback Period (Years)	40.63	47.69	45.33	57.16

Table 22. Break-down of payback for Upgrade 3 in deployed environment

Estimated Time Required for Payback of Upgrade (OCONUS)				
	MTVR		LVSR	
	<u>2</u>	<u>4</u>	<u>4</u>	<u>6</u>
Number of In Wheel Motors Installed				
Savings of Fuel from Upgrade Propelling the Vehicle per Yr	\$1,545.85	\$2,036.59	\$2,142.70	\$2,299.74
Cost of Upgrade	\$9,630.32	\$14,893.04	\$14,893.04	\$20,155.76
Payback Period (Years)	6.23	7.31	6.95	8.76

E. UPGRADE 4: IMPROVED STARTED BATTERIES

Upgrade 4’s estimated cost for acquisition and installation is **\$1,952.92** for the MTVR, and **\$3,751.92** for the LVSR, with calculations provided in Table 23. This is a result of the LVSR requiring twice the additional starter batteries the MTVR does. The batteries used in this particular upgrades’ calculations is Navistas’ 6T Lithium ion starter battery.

Table 23. Cost break-down of Upgrade 4

Acquisition Input Parameters	
Avg Cost of Labor Man-Hour-MCLB Barstow	\$76.96
Total Man-hours for Equipment Installation	2
Total Labor Cost for Installation-MCLB Barstow	\$153.92
Cost Per APU Battery (6T Li Batt 24V DC)	\$899.50
Number of batteries per System	2 (MTVR)
	4 (LVSR)
Cost of Renewable-Energy Suite	
MTVR w/ (2) 6T Li Batt 24V DC	\$1,952.92
LVSR w/ (4) 6T Li Batt 24V DC	\$3,751.92

At this point Upgrade 4 is removed from the analysis. Because the starter batteries currently installed on the MTVR and LVSR are already capable of providing the

necessary power for auxiliary systems within a training day’s assumed six hours of idle time. As a result, there is no benefit to be gained from upgrading the starter batteries.

F. UPGRADE 5: FLEXIBLE SOLAR ARRAY

The grand total for the procurement and installation of Upgrade 5 is **\$747.84** for both the MTRV and LVSR, which ends up being the cheapest upgrade option. A break-down of the cost calculations is provided in Table 24. Ultimately however, Upgrade 5 is removed from further consideration and not included in the cost-benefit analysis similar to the justification for the removal of Upgrade 4 from consideration.

Table 24. Cost break-down of Upgrade 5

Acquisition Input Parameters	
Renewable-Energy Unit Cost (Solar Array)	\$440.00
Cost of Labor Man-Hour-MCLB Barstow	\$76.96
Total Man-hours for Equipment Installation	4
Total Labor Cost for Installation	\$307.84
Cost of Upgrade	
Flexible Solar Array	\$747.84

Because the existing batteries are already capable of powering the communication suite during the established training day, the solar panels provide no added benefit in power generation. Additionally, the solar panels provide no guarantee against a completely drained battery in case the training day exceeds the assumed six hours, or if additional auxiliary systems are powered, as in the case of Upgrade 1.

This being the case, a solar system is redundant for CONUS training. The solar might be useful, however, in:

- An operational environment where minimizing noise signature is highly valuable.

- For bigger communication set-ups that use a lot more energy, in which case solar reduces the amount of idling time or generator use.

In each case, the energy generated by solar depends on the exact location of operations, time of year, and time of day. These factors make solar panels a relatively unreliable source of power generation.

Table 25. NPV worksheet for upgrade 1 in CONUS environment (MTVR & LVSR)

Life Cycle Cost Worksheet																						
Discount Rate (%)-->	2.50%	<--Yellow Cells Are For Dat: You can input values in the highlighted cells only.																				
Net Present Value -->	\$25,041																					
YR	2020	2021	2022	2023	2024	2025	2026	2027	2028	2029	2030	2031	2032	2033	2034	2035	2036	2037	2038	2039	2040	2041
R & D																						
System Acquisition	\$1,761																					
O&M, and other costs																						
Operations & Maintenance																						
Personnel Cost																						
Revenue/Savings																						
Revenue/Savings (use positive #s)		\$1,656	\$1,656	\$1,656	\$1,656	\$1,656	\$1,656	\$1,656	\$1,656	\$1,656	\$1,656	\$1,656	\$1,656	\$1,656	\$1,656	\$1,656	\$1,656	\$1,656	\$1,656	\$1,656	\$1,656	\$1,656
Acquistion & Capital Investment	\$1,761	\$0	\$0	\$0	\$0	\$0	\$0	\$0	\$0	\$0	\$0	\$0	\$0	\$0	\$0	\$0	\$0	\$0	\$0	\$0	\$0	\$0
R&D, O&M, and other costs		\$0	\$0	\$0	\$0	\$0	\$0	\$0	\$0	\$0	\$0	\$0	\$0	\$0	\$0	\$0	\$0	\$0	\$0	\$0	\$0	\$0
Revenue/Savings		\$1,656	\$1,656	\$1,656	\$1,656	\$1,656	\$1,656	\$1,656	\$1,656	\$1,656	\$1,656	\$1,656	\$1,656	\$1,656	\$1,656	\$1,656	\$1,656	\$1,656	\$1,656	\$1,656	\$1,656	\$1,656
Net Cash Flow																						
		-\$1,761	\$1,656	\$1,656	\$1,656	\$1,656	\$1,656	\$1,656	\$1,656	\$1,656	\$1,656	\$1,656	\$1,656	\$1,656	\$1,656	\$1,656	\$1,656	\$1,656	\$1,656	\$1,656	\$1,656	\$1,656

Table 26. NPV worksheet for upgrade 1 in OCONUS environment (MTVR & LVSR)

Life Cycle Cost Worksheet																						
Discount Rate (%)->	2.50%	<-Yellow Cells Are For Data You can input values in the highlighted cells only.																				
Net Present Value -->	\$173,032																					
YR	2020	2021	2022	2023	2024	2025	2026	2027	2028	2029	2030	2031	2032	2033	2034	2035	2036	2037	2038	2039	2040	2041
R & D																						
System Acquisition	\$1,761																					
O&M, and other costs																						
Operations & Maintenance																						
Personnel Cost																						
Revenue/Savings																						
Revenue/Savings (use positive #s)		\$10,800	\$10,800	\$10,800	\$10,800	\$10,800	\$10,800	\$10,800	\$10,800	\$10,800	\$10,800	\$10,800	\$10,800	\$10,800	\$10,800	\$10,800	\$10,800	\$10,800	\$10,800	\$10,800	\$10,800	\$10,800
Acquisition & Capital Investment	\$1,761	\$0	\$0	\$0	\$0	\$0	\$0	\$0	\$0	\$0	\$0	\$0	\$0	\$0	\$0	\$0	\$0	\$0	\$0	\$0	\$0	\$0
R&D, O&M, and other costs		\$0	\$0	\$0	\$0	\$0	\$0	\$0	\$0	\$0	\$0	\$0	\$0	\$0	\$0	\$0	\$0	\$0	\$0	\$0	\$0	\$0
Revenue/Savings		\$10,800	\$10,800	\$10,800	\$10,800	\$10,800	\$10,800	\$10,800	\$10,800	\$10,800	\$10,800	\$10,800	\$10,800	\$10,800	\$10,800	\$10,800	\$10,800	\$10,800	\$10,800	\$10,800	\$10,800	\$10,800
Net Cash Flow		-\$1,761	\$10,800	\$10,800	\$10,800	\$10,800	\$10,800	\$10,800	\$10,800	\$10,800	\$10,800	\$10,800	\$10,800	\$10,800	\$10,800	\$10,800	\$10,800	\$10,800	\$10,800	\$10,800	\$10,800	\$10,800

V. COST—BENEFIT ANALYSIS

A. COMPARISON CRITERIA

All but one of the upgrade options provide financial benefits to the Marine Corps through varying reductions in fuel consumption; all upgrades with the exception of Upgrade 1 also provide the vehicle operator with electricity to power their auxiliary systems. The reduction in engine idling that each upgrade option delivers also allows the vehicle operator to reduce their sound and heat signature while operating in the tactical environment. This chapter provides a cost-benefit analysis to identify which upgrade option is the most economical for each vehicle for the remainder of their respective service life. The criteria for the analysis compare each upgrade by their respective financial characteristics:

1. Initial acquisition and installation cost
2. Estimated payback period

A percentage of installation and break-even costs form the y-axis, while a measurement of the NPV and yearly savings percentage form the x-axis. A graphical representation of the data points provides a visual of the most economical upgrade, as it will be plotted in the upper right quadrant. The least economical upgrade will appear closer to the bottom left. Figure 17 provides a guideline and basis of how to interpret the graphical representation of the results. Intuitively, benefits increase as one moves along the axes.

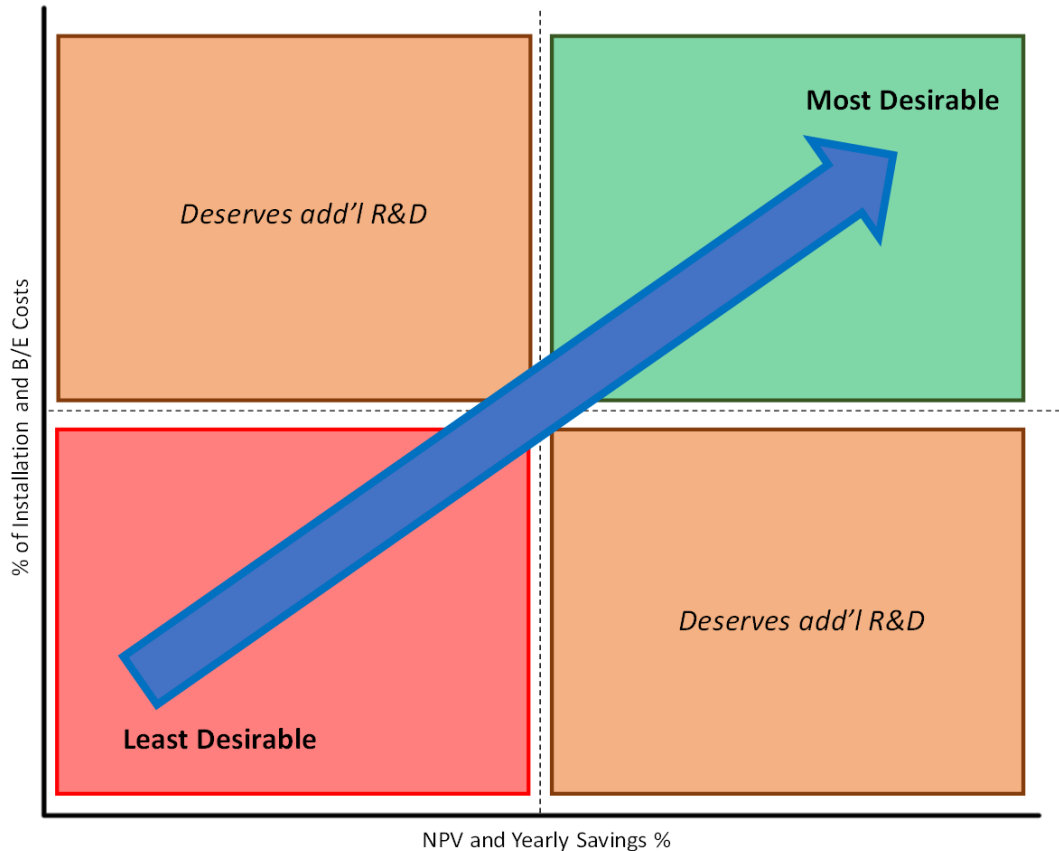

Figure 17. Graphical representation of cost-benefit analysis

B. CALCULATIONS

1. Y-Axis

The value used for each upgrade along the “Percent Advantage of Upgrade’s Breakeven Time (Training Years)” (y-axis) was calculated in the following steps:

Divide the upgrade’s respective break-even time (in training years) by the longest (or largest) break-even time among all the upgrade options. In this analysis, the upgrade with the longest breakeven time is upgrade 3(b), specifically the in-wheel regenerative braking system.

$$\text{Breakeven Time in Training Years (Upgrade X)} \div \text{Max. Breakeven Time in Training Years} = \% \text{ of the Longest Breakeven Cycle}$$

Since smaller values of the previous calculations yield a more desirable Breakeven Time, the reciprocal is calculated to depict this result in the upper right quadrant.

$$100\% - (\text{Upgrade X}) \% \text{ of the Longest Breakeven Cycle} = \text{Reciprocal } \%$$

2. X-Axis

The value used for each upgrade along the “Percent Advantage of Upgrade’s Cost of Acquisition and Installation” (x-axis) was calculated in the following steps:

Divide the upgrade’s respective Acquisition and Installation Cost by the highest acquisition and installation cost amongst all the upgrade options. In this analysis, the upgrade with the highest cost is also upgrade 3(b) – the in-wheel regenerative braking system.

$$\text{Acquisition and Installation Cost (Upgrade X)} \div \text{Max. Acquisition and Installation Cost} = \% \text{ of the Costliest Installation}$$

Since smaller values of the previous calculations yield a more desirable acquisition and installation cost, the reciprocal is calculated to depict this result in the upper right quadrant.

$$100\% - (\text{Upgrade X}) \% \text{ of the Costliest Installation} = \text{Reciprocal } \%$$

Tables 27 and 28 displays the calculations for each upgrade option applied to the MTRV and LVSR, respectively, with their respective percentage values highlighted in grey. Upgrades 4 and 5 were removed from the analysis because it was determined earlier in this study that their respective capabilities were no longer desirable in comparison to the remaining upgrades. Therefore, no breakeven time was calculated for Upgrades 4 and 5.

C. RESULTS

Figures 18 and 19 illustrate the most beneficial upgrade options for the MTRV and LVSR, respectively. Based on the graphical representation, Upgrade 1 appears to be the most economical and a clear “winner.” Upgrade 2 falls on the cusp, encouraging

further study and improvement, especially for the LVSR. These upgrades are in no particular order; a decision-maker needs to first establish which criteria has a higher priority for the Marine Corps. Does the overall NPV and yearly savings have higher priority or is the installation and break-even cost more important? If the Marine Corps' priority is neither and a proof of concept with regenerative braking would rather be pursued, Upgrade 2 would be the best candidate for prototyping. Tables 27 and 28 at the end of this chapter is a consolidated table of the values calculated for the cost-benefit analysis.

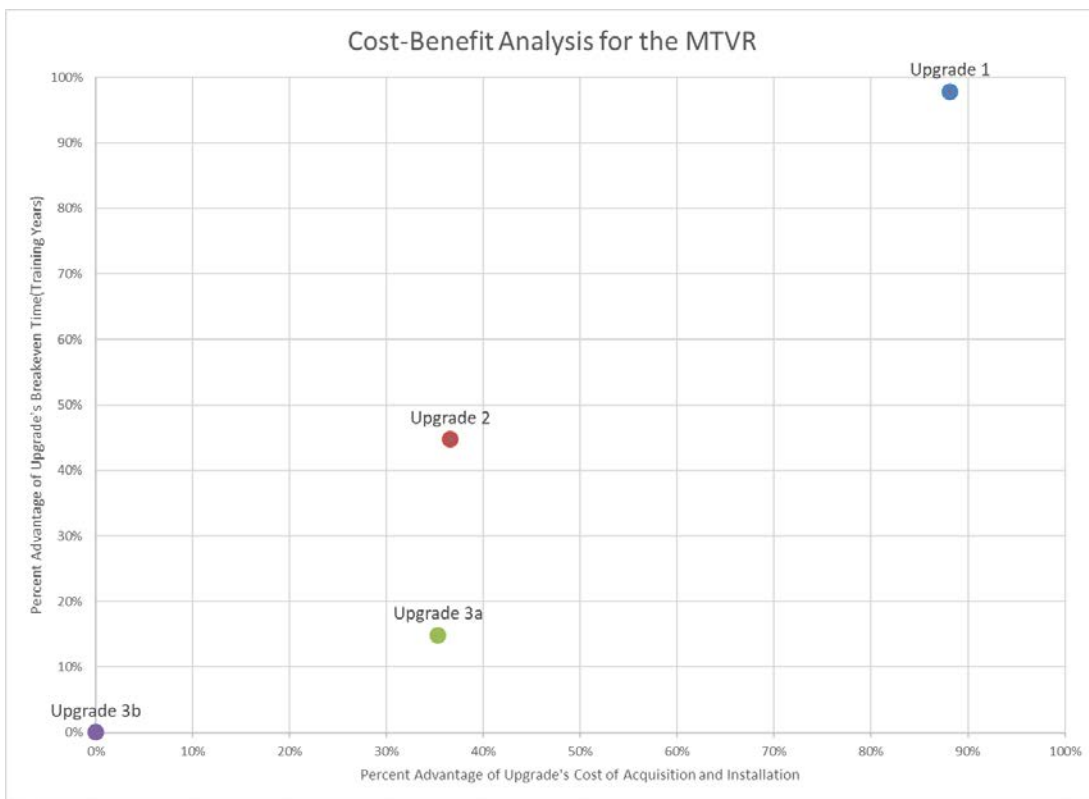

Figure 18. Cost-benefit analysis for the MTRV

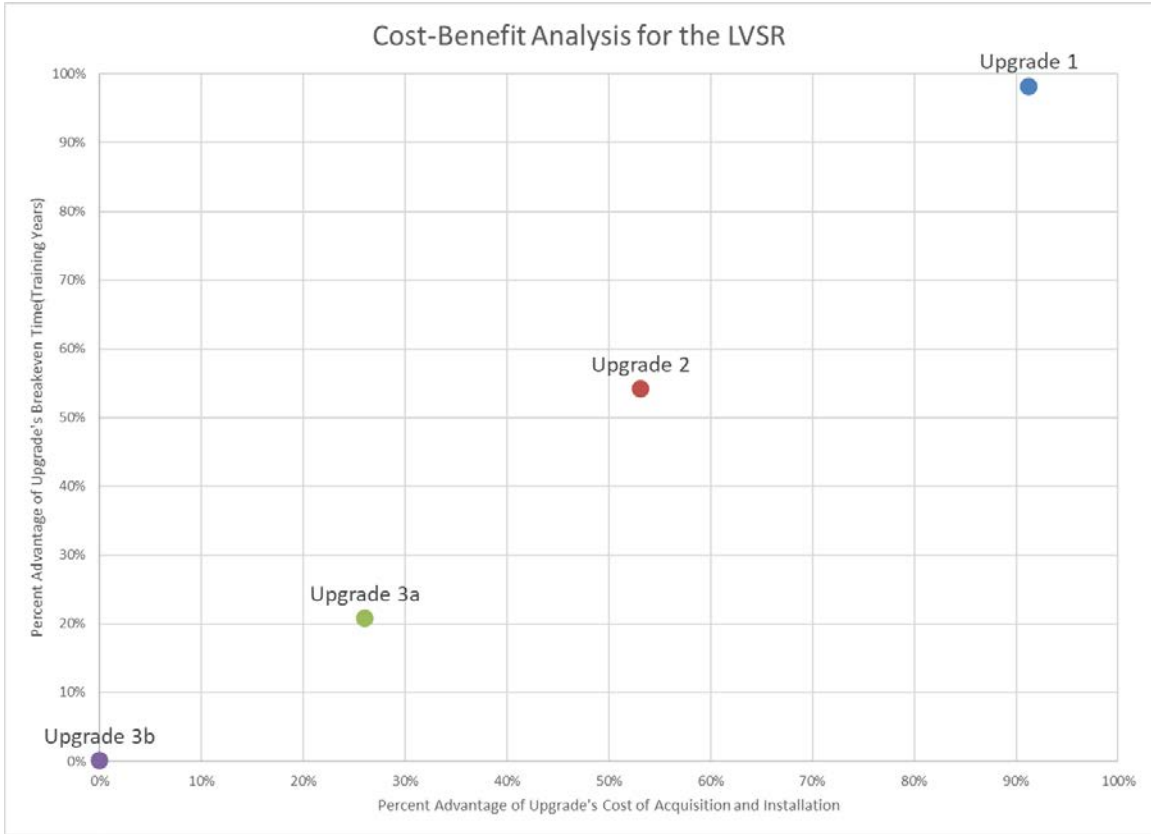

Figure 19. Cost-benefit analysis for the LVSR

Table 27. Consolidated cost-benefit analysis calculations for the MTRV

MTRV							
<u>Upgrade</u>	<u>Description</u>	<u>Acquisition & Installation Cost</u>	<u>B/E Time (Yrs)</u>	<u>% of the Costliest Installation</u>	<u>Reciprocal for Graphing Purposes</u>	<u>% of the Longest B/E Cycle</u>	<u>Reciprocal for Graphing Purposes</u>
1	Anti-Idling Device, Supercapacitor & Emergency Override	\$1,760.76	1.06	12%	88%	2%	98%
2	Drivetrain Regenerative Braking System	\$9,438.16	26.39	63%	37%	55%	45%
3(a)	In-Wheel Regenerative Braking System (2-Wheel)	\$9,630.32	40.63	65%	35%	85%	15%
3(b)	In-Wheel Regenerative Braking System (4-Wheel)	\$14,893.04	47.69	100%	0%	100%	0%
4	Improved Starter Batteries	\$1,952.92		13%	87%		
5	Flexible Solar Array	\$747.84		5%	95%		

Table 28. Consolidated cost-benefit calculations for the LVSR

LVSR							
<u>Upgrade</u>	<u>Description</u>	<u>Acquisition & Installation Cost</u>	<u>B/E Time (Yrs)</u>	<u>% of the Costliest Installation</u>	<u>Reciprocal for Graphing Purposes</u>	<u>% of the Longest B/E Cycle</u>	<u>Reciprocal for Graphing Purposes</u>
1	Anti-Idling Device, Supercapacitor & Emergency Override	\$1,760.76	1.06	9%	91%	2%	98%
2	Drivetrain Regenerative Braking System	\$9,438.16	26.23	47%	53%	46%	54%
3(a)	In-Wheel Regenerative Braking System (4-Wheel)	\$14,893.04	45.33	74%	26%	79%	21%
3(b)	In-Wheel Regenerative Braking System (6-Wheel)	\$20,155.76	57.16	100%	0%	100%	0%
4	Improved Starter Batteries	\$3,751.92		19%	81%		
5	Flexible Solar Array	\$747.84		4%	96%		

D. SENSITIVITY ANALYSIS

As Upgrade 1 revealed itself as the only option worth adopting immediately based on the CONUS training assumptions, a sensitivity analysis was applied to this upgrade only. Despite Upgrade 1 being the most economical choice for fuel savings, there is significant resistance to adopting idle-reduction technology (Gallenson & Salem, 2014). It would therefore be prudent to incorporate the technology into a limited number of tactical vehicles initially. As such, the sensitivity analysis for this thesis examines the fiscal impacts of incorporating the technology into different percentages of the fleet of Marine Corps MTRVs and LVSRs.

A MTRV fleet size of 11,000 and a fleet of 2,000 LVSRs were used as planning factors in this sensitivity analysis. A “pessimistic,” “expected,” and “optimistic” level was analyzed, corresponding to integration of Upgrade 1 into 25%, 50%, and 75% of the vehicle fleets, respectively. Potential cost savings in both CONUS and OCONUS environments were calculated. Intuitively, the greater the number of vehicles into which Upgrade 1 is incorporated, the greater the potential savings, with a significant amount being realized with a fully burdened cost of \$18 per gallon for a hostile, or OCONUS, environment. Figure 20 summarizes the findings of the sensitivity analysis, with these levels and planning factors outlined.

For example, in the optimistic scenario where 75% of MTRVs are equipped with idle-reduction devices, the Marine Corps is calculated to save over \$206M throughout the remaining 20-year service life in CONUS.

Although not calculated in this study, other intuitive impacts to cost savings would be the amount of time a vehicle idles in a day, the number of auxiliary systems on a vehicle and their respective amperage draw, and the number of days employed. With an increase in each of these factors, the potential for cost savings also increases.

Utilizing DLA's cost of JP-8 @ \$2.76/Gal "CONUS"	MTRV (Upgrade 1)		Outcomes			Fleet Savings for Period 2021-2041		
	<u>Variables</u>		<u>Pessimistic</u>	<u>Expected</u>	<u>Optimistic</u>	<u>Pessimistic</u>	<u>Expected</u>	<u>Optimistic</u>
	Number of Vehicles in the Marine Corps	11,000						
	Percentage of Vehicles with Upgrade 1		25%	50%	75%	\$68,862,344.19	\$137,724,688.39	\$206,587,032.58
	Number of MTRVs with Upgrade 1		2,750	5,500	8,250			
Utilizing the Estimated FBCF JP-8 @ \$18/Gal "OCONUS"	LVSr (Upgrade 1)		Outcomes			Fleet Savings for Period 2021-2041		
	<u>Variables</u>		<u>Pessimistic</u>	<u>Expected</u>	<u>Optimistic</u>	<u>Pessimistic</u>	<u>Expected</u>	<u>Optimistic</u>
	Number of Vehicles in the Marine Corps	2,000						
	Number of LVSrs with Upgrade 1		25%	50%	75%	\$12,520,426.22	\$25,040,852.43	\$37,561,278.65
	Avg Amperage Hour Draw		500	1,000	1,500			
Utilizing the Estimated FBCF JP-8 @ \$18/Gal "OCONUS"	MTRV (Upgrade 1)		Outcomes			Fleet Savings for Period 2021-2041		
	<u>Variables</u>		<u>Pessimistic</u>	<u>Expected</u>	<u>Optimistic</u>	<u>Pessimistic</u>	<u>Expected</u>	<u>Optimistic</u>
	Number of Vehicles in the Marine Corps	11,000						
	Percentage of Vehicles with Upgrade 1		25%	50%	75%	\$475,839,002.57	\$951,678,005.14	\$1,427,517,007.71
	Number of MTRVs with Upgrade 1		2,750	5,500	8,250			
Utilizing the Estimated FBCF JP-8 @ \$18/Gal "OCONUS"	LVSr (Upgrade 1)		Outcomes			Fleet Savings for Period 2021-2041		
	<u>Variables</u>		<u>Pessimistic</u>	<u>Expected</u>	<u>Optimistic</u>	<u>Pessimistic</u>	<u>Expected</u>	<u>Optimistic</u>
	Number of Vehicles in the Marine Corps	2,000						
	Number of LVSrs with Upgrade 1		25%	50%	75%	\$86,516,182.29	\$173,032,364.57	\$259,548,546.86
	Avg Amperage Hour Draw		500	1,000	1,500			

Figure 20. Sensitivity analysis results (per year)

THIS PAGE INTENTIONALLY LEFT BLANK

VI. CONCLUSIONS AND RECOMMENDATIONS

A. CONCLUSIONS

Regenerative braking and idle-reduction systems are both capable of reducing the energy use of USMC vehicles. For regenerative systems, the system's efficacy is however, dependent on the efficiency and capabilities of the components of the particular system or "upgrade." While there exists a significant amount of potential energy to be "captured" during braking activities, the limitations imposed by parasitic losses, component efficiency, and battery capabilities affect the viability of regenerative braking.

Neither of the regenerative braking systems (drivetrain and in-wheel) analyzed resulted in a payback period within the vehicle's expected remaining service life when analyzed for a garrison environment (i.e., "CONUS"). The regenerative braking system with the shortest payback time was Upgrade 2 (specifically for the LVSR), at just over 26 years. Upgrade 3's payback period ranged from 40.63 to 57.16 years (in a CONUS environment).

Given the significantly greater cost of a gallon of fuel in a deployed, or OCONUS environment, the payback periods were much less. Even so, the payback period for the regenerative braking system ranged from four (Upgrade 2) to nearly nine years (Upgrade 3 for LVSR, six-wheels). The payback period for the idle-reduction system was completed in just over a month.

Although it was desired that regenerative braking systems might provide a viable way of reducing energy, the benefits of reducing idling provide the same opportunities. Reducing the amount of time that a vehicle idles its engines also results in increased fuel efficiency, which contribute to the flexibility and reach of our military forces, which simultaneously reducing the numbers of trucks and people dedicated to refueling. Not idling the internal combustion engine also lowers the heat and sound signatures of operating units, which in turn increases the lethality of units. These are all benefits that no monetary value can necessarily be attributed that could be realized with the integration

of idling-reduction systems. There are also reduced maintenance costs as a result from not idling the trucks for extended periods of time, which equates to less wear and tear.

When selecting a preferred regenerative braking system, the intent, or purpose, of the system must be emphasized. Regenerative braking is not a goal in and of itself; instead, the requirement to power electrical systems and/or reduce the burden of fuel is the goal. As such, regenerative braking does not prove to be the most effective means of accomplishing that goal. To meet the intent of the acquisition system and specifically, the KPPs of a vehicular program of record, this analysis showed there are other energy recovery systems that provide “more bang for the buck.”

As is often the case, sometimes the best solution is the simplest one. Along this vein, it is the authors conclusion the upgrade which should be selected and pursued for immediate implementation is Upgrade 1, the idling-reduction package. Except for the solar array, this system has the lowest up-front costs. The relative ease with which it could be installed also means there exists the potential that vehicles will not have to wait until they arrive at Barstow or Albany for a complete overhaul. As such, benefits could start to be realized quickly. Additionally, the payback period for Upgrade 1 is the shortest by a wide margin. Only one other system promised a payback period in a garrison environment within the vehicle’s expected remaining service life.

B. RECOMMENDATIONS

While the regenerative braking systems were found to provide an ancillary power source, their extended payback period do not make them a viable alternative at this point in time. Further research and development must be done to make the systems more efficiency and effective at “capturing” energy in addition to making the components cheaper.

As with any system or piece of equipment entertained for military use, further engineering must be done to ensure they can withstand the demands placed upon them by the military in a harsh environment. If there comes a time when regenerative braking systems do become cost-effective, they must also be developed and evaluated for their

robustness. The potential for down-time and required maintenance may keep these systems from being sustainable for military applications.

Based on this analysis' findings, integration of idling-reduction technology should be immediately pursued. This is a relatively simple and cheap change that would provide an almost immediate return on investment. While it is a well-known fact that simply turning a vehicle off will reduce fuel costs, the imbedded belief a vehicle's batteries will be quickly drained and unable to start again have prevented this action from taking place (Gallenson & Salem, 2014). With override systems and inclusion of a supercapacitor however, this concern becomes irrelevant. With a fail-safe and emergency over-ride this reasoning is no longer justified. The idle-reduction technology would serve as a forcing function to reducing the burden of fuel and subsequently increasing operational flexibility.

THIS PAGE INTENTIONALLY LEFT BLANK

APPENDIX A. EXCEL SPREADSHEET

This appendix provides a visual of the master Excel spreadsheet used to calculate the potential energy created during the established hour-long driving schedule. Different views, or snapshots, of the spreadsheet depicting the amount of that potential energy captured for follow-on use by each of the upgrades is also depicted. These two views of calculations are provided for both the MTRV and LVSR.

Specifically, Figure 21 is a snapshot of the master spreadsheet used to calculate the potential energy generated by the MTRV, while Figure 23 provides the same visual for the LVSR. Figures 22 and 24 provide a snapshot of the spreadsheet in which calculations are included to determine the energy effectively captured by each of the upgrades for the MTRV and LVSR, respectively.

	A	B	D	E	F	G	H	I	J	K	L	M	N	O	P	Q	R	S	T	U	V		
1	HUDDSCOLHUDDDS - Urban Dynamometer Driving Schedule for																						
2	Heavy Duty Vehicles											ideal		Gravel		RR Power		Frontal		Drag Power		W/ Drag	
3	Test Time, secs	Vehicle Speed, mph	m/sec	Veh Mass	Energy	Δ E	Δ E Accel	Δ E Decel	Coeff RR	Grav Constant	Veh Weight	RR Force	P _{rr}	Area	Air Density	Coeff Drag	Drag Force	P _d		Δ E Decel			
44	40.00	14.00	6.26	28,239.00	553,054.79	91,468.21	91,468.21	0.00	0.02	9.81	277,024.59	5,540.49	34,675.50	8.93	1.20	0.76	159.53	998.43		0.00			
45	41.00	12.58	5.62	28,239.00	446,553.37	-106,501.42	0.00	-106,501.42	0.02	9.81	277,024.59	5,540.49	31,158.41	8.93	1.20	0.76	128.81	724.40		-74,618.61			
46	42.00	12.87	5.75	28,239.00	467,378.98	20,825.62	20,825.62	0.00	0.02	9.81	277,024.59	5,540.49	31,876.69	8.93	1.20	0.76	134.82	775.66		0.00			
47	43.00	13.00	5.81	28,239.00	476,868.67	9,489.69	9,489.69	0.00	0.02	9.81	277,024.59	5,540.49	32,198.68	8.93	1.20	0.76	137.55	799.40		0.00			
48	44.00	13.00	5.81	28,239.00	476,868.67	0.00	0.00	0.00	0.02	9.81	277,024.59	5,540.49	32,198.68	8.93	1.20	0.76	137.55	799.40		0.00			
49	45.00	13.68	6.12	28,239.00	528,061.23	51,192.56	51,192.56	0.00	0.02	9.81	277,024.59	5,540.49	33,882.92	8.93	1.20	0.76	152.32	931.52		0.00			
50	46.00	15.00	6.71	28,239.00	634,884.33	106,823.10	106,823.10	0.00	0.02	9.81	277,024.59	5,540.49	37,152.32	8.93	1.20	0.76	183.13	1,228.03		0.00			
51	47.00	15.00	6.71	28,239.00	634,884.33	0.00	0.00	0.00	0.02	9.81	277,024.59	5,540.49	37,152.32	8.93	1.20	0.76	183.13	1,228.03		0.00			
52	48.00	13.37	5.98	28,239.00	504,399.79	-130,484.53	0.00	-130,484.53	0.02	9.81	277,024.59	5,540.49	33,115.10	8.93	1.20	0.76	145.50	869.62		-96,499.81			
53	49.00	12.08	5.40	28,239.00	411,761.71	-92,638.09	0.00	-92,638.09	0.02	9.81	277,024.59	5,540.49	29,920.00	8.93	1.20	0.76	118.77	641.41		-62,076.68			
54	50.00	12.26	5.48	28,239.00	424,124.17	12,362.47	12,362.47	0.00	0.02	9.81	277,024.59	5,540.49	30,365.83	8.93	1.20	0.76	122.34	670.51		0.00			
55	51.00	14.29	6.39	28,239.00	576,204.37	152,080.19	152,080.19	0.00	0.02	9.81	277,024.59	5,540.49	35,393.78	8.93	1.20	0.76	166.21	1,061.77		0.00			
56	52.00	14.56	6.51	28,239.00	598,184.06	21,979.70	21,979.70	0.00	0.02	9.81	277,024.59	5,540.49	36,062.52	8.93	1.20	0.76	172.55	1,123.10		0.00			
57	53.00	15.20	6.80	28,239.00	651,927.44	53,743.38	53,743.38	0.00	0.02	9.81	277,024.59	5,540.49	37,647.69	8.93	1.20	0.76	188.05	1,277.81		0.00			
58	54.00	16.76	7.49	28,239.00	792,611.04	140,683.59	140,683.59	0.00	0.02	9.81	277,024.59	5,540.49	41,511.53	8.93	1.20	0.76	228.63	1,713.00		0.00			
59	55.00	17.00	7.60	28,239.00	815,473.64	22,862.61	22,862.61	0.00	0.02	9.81	277,024.59	5,540.49	42,105.96	8.93	1.20	0.76	235.23	1,787.65		0.00			
60	56.00	17.00	7.60	28,239.00	815,473.64	0.00	0.00	0.00	0.02	9.81	277,024.59	5,540.49	42,105.96	8.93	1.20	0.76	235.23	1,787.65		0.00			
61	57.00	17.23	7.70	28,239.00	837,688.67	22,215.03	22,215.03	0.00	0.02	9.81	277,024.59	5,540.49	42,675.63	8.93	1.20	0.76	241.63	1,861.19		0.00			
62	58.00	18.77	8.39	28,239.00	994,124.17	156,435.50	156,435.50	0.00	0.02	9.81	277,024.59	5,540.49	46,489.94	8.93	1.20	0.76	286.76	2,406.18		0.00			
63	59.00	20.54	9.18	28,239.00	1,190,454.95	196,330.78	196,330.78	0.00	0.02	9.81	277,024.59	5,540.49	50,873.91	8.93	1.20	0.76	343.39	3,153.09		0.00			
64	60.00	19.60	8.76	28,239.00	1,083,987.39	-106,467.56	0.00	-106,467.56	0.02	9.81	277,024.59	5,540.49	48,545.70	8.93	1.20	0.76	312.68	2,739.70		-55,182.16			
65	61.00	18.14	8.11	28,239.00	928,510.14	-155,477.25	0.00	-155,477.25	0.02	9.81	277,024.59	5,540.49	44,929.54	8.93	1.20	0.76	267.83	2,171.93		-108,375.77			
66	62.00	17.98	8.04	28,239.00	912,202.93	-16,307.22	0.00	-16,307.22	0.02	9.81	277,024.59	5,540.49	44,533.25	8.93	1.20	0.76	263.13	2,114.97		0.00			
67	63.00	17.00	7.60	28,239.00	815,473.64	-96,729.28	0.00	-96,729.28	0.02	9.81	277,024.59	5,540.49	42,105.96	8.93	1.20	0.76	235.23	1,787.65		-52,835.67			
68	64.00	16.34	7.30	28,239.00	753,383.65	-62,089.99	0.00	-62,089.99	0.02	9.81	277,024.59	5,540.49	40,471.26	8.93	1.20	0.76	217.32	1,587.42		-20,031.31			
69	65.00	15.00	6.71	28,239.00	634,884.33	-118,499.33	0.00	-118,499.33	0.02	9.81	277,024.59	5,540.49	37,152.32	8.93	1.20	0.76	183.13	1,228.03		-80,118.97			
70	66.00	15.00	6.71	28,239.00	634,884.33	0.00	0.00	0.00	0.02	9.81	277,024.59	5,540.49	37,152.32	8.93	1.20	0.76	183.13	1,228.03		0.00			
71	67.00	15.00	6.71	28,239.00	634,884.33	0.00	0.00	0.00	0.02	9.81	277,024.59	5,540.49	37,152.32	8.93	1.20	0.76	183.13	1,228.03		0.00			
72	68.00	15.96	7.13	28,239.00	718,750.00	83,865.68	83,865.68	0.00	0.02	9.81	277,024.59	5,540.49	39,530.07	8.93	1.20	0.76	207.33	1,479.22		0.00			
73	69.00	12.35	5.52	28,239.00	430,373.98	-288,376.03	0.00	-288,376.03	0.02	9.81	277,024.59	5,540.49	30,588.74	8.93	1.20	0.76	124.14	685.39		-257,101.90			
74	70.00	15.28	6.83	28,239.00	658,807.90	228,433.92	228,433.92	0.00	0.02	9.81	277,024.59	5,540.49	37,845.83	8.93	1.20	0.76	190.04	1,298.09		0.00			
75	71.00	14.27	6.38	28,239.00	574,592.61	-84,215.29	0.00	-84,215.29	0.02	9.81	277,024.59	5,540.49	35,344.24	8.93	1.20	0.76	165.74	1,057.32		-47,813.73			
76	72.00	12.59	5.63	28,239.00	447,263.59	-127,329.01	0.00	-127,329.01	0.02	9.81	277,024.59	5,540.49	31,183.18	8.93	1.20	0.76	129.01	726.13		-95,419.71			
77	73.00	12.25	5.48	28,239.00	423,432.57	-23,831.02	0.00	-23,831.02	0.02	9.81	277,024.59	5,540.49	30,341.06	8.93	1.20	0.76	122.14	668.87		0.00			
78	74.00	9.28	4.15	28,239.00	243,000.99	-180,431.59	0.00	-180,431.59	0.02	9.81	277,024.59	5,540.49	22,984.90	8.93	1.20	0.76	70.09	290.79		-157,155.89			
79	75.00	8.00	3.58	28,239.00	180,589.32	-62,411.67	0.00	-62,411.67	0.02	9.81	277,024.59	5,540.49	19,814.57	8.93	1.20	0.76	52.09	186.30		-42,410.80			
80	76.00	8.00	3.58	28,239.00	180,589.32	0.00	0.00	0.00	0.02	9.81	277,024.59	5,540.49	19,814.57	8.93	1.20	0.76	52.09	186.30		0.00			
81	77.00	8.38	3.75	28,239.00	198,152.76	17,563.44	17,563.44	0.00	0.02	9.81	277,024.59	5,540.49	20,755.76	8.93	1.20	0.76	57.16	214.12		0.00			
82	78.00	9.53	4.26	28,239.00	256,270.07	58,117.31	58,117.31	0.00	0.02	9.81	277,024.59	5,540.49	23,604.11	8.93	1.20	0.76	73.92	314.93		0.00			
83	79.00	10.69	4.78	28,239.00	322,453.80	66,183.73	66,183.73	0.00	0.02	9.81	277,024.59	5,540.49	26,477.22	8.93	1.20	0.76	93.01	444.50		0.00			
84	80.00	11.00	4.92	28,239.00	341,426.68	18,972.88	18,972.88	0.00	0.02	9.81	277,024.59	5,540.49	27,245.04	8.93	1.20	0.76	98.49	484.30		0.00			
85	81.00	9.00	4.02	28,239.00	228,558.36	-112,868.32	0.00	-112,868.32	0.02	9.81	277,024.59	5,540.49	22,291.39	8.93	1.20	0.76	65.93	265.25		-90,311.68			
86	82.00	9.00	4.02	28,239.00	228,558.36	0.00	0.00	0.00	0.02	9.81	277,024.59	5,540.49	22,291.39	8.93	1.20	0.76	65.93	265.25		0.00			
1065																							
1066			25.93			0.00	34,469,901.92	-34,469,901.92	joules										70,993.52		-21,134,468.13	joules	
1067								-797.91	Ah										70.99		-830.76	Amps	
1068																						24V Batt	
1069																						-552,655.74	W

Figure 21. Master MTRV spreadsheet snapshot: Energy generated from driving schedule

	AD	AE	AF	AG	AH	AI	AJ	AQ	AR	AS	AT	AU	AV	AW	AX	AY	AZ	BA	BB	BC	BD	BE	BF	BG	BH	BI
1		Drive Train Regen			Existing Armasafe Batteries (2 Batteries in Parallel w/ max current of 1.728 I/sec (ea))								In-Wheel Regen										Existing Armasafe Batteries (2 Batteries in Parallel w/ max current of 1.728 I/sec (ea))			
2	Power Avail @74.4%	40000W			Joules/sec			m									Power Avail	80000W	Single-Wheel			MTRV				
3	93% eff of the Drive Train Regen & 80% eff at the Torque Converter	Drive Train Regen			Max Current	Max Stored		Tire Dia	Angle Vel	Wh rpm		Num of Wheels	Torque	Max Torque	Usable Torque	Max Power w/Lim Torque	70% eff from each In-Wheel Motor	Peak Gen Power based off # of Wheels	In Wheel Regen		Number of Motor Wheels	In Wheel Regen	Max Current	Max Stored		
44	0.00	-40,000.00	0.00		-3,456.00	0.00	1.34	4.19	40.04	6.00	0.00	-1,250.00	0.00	0.00	0.00	0.00	0.00	-80,000.00	0.00	2.00	0.00		-3,456.00	0.00		
45	-55,516.25	-40,000.00	-40,000.00		-3,456.00	-3,456.00	1.34	3.77	35.98	6.00	-3,300.61	-1,250.00	-1,250.00	-1,250.00	-4,709.90	-52,233.03	-80,000.00	-4,709.90	2.00	0.00	-9,419.80		-3,456.00	-3,456.00		
46	0.00	-40,000.00	0.00		-3,456.00	0.00	1.34	3.85	36.81	6.00	0.00	-1,250.00	0.00	0.00	0.00	0.00	0.00	-80,000.00	0.00	2.00	0.00		-3,456.00	0.00		
47	0.00	-40,000.00	0.00		-3,456.00	0.00	1.34	3.89	37.18	6.00	0.00	-1,250.00	0.00	0.00	0.00	0.00	0.00	-80,000.00	0.00	2.00	0.00		-3,456.00	0.00		
48	0.00	-40,000.00	0.00		-3,456.00	0.00	1.34	3.89	37.18	6.00	0.00	-1,250.00	0.00	0.00	0.00	0.00	0.00	-80,000.00	0.00	2.00	0.00		-3,456.00	0.00		
49	0.00	-40,000.00	0.00		-3,456.00	0.00	1.34	4.10	39.13	6.00	0.00	-1,250.00	0.00	0.00	0.00	0.00	0.00	-80,000.00	0.00	2.00	0.00		-3,456.00	0.00		
50	0.00	-40,000.00	0.00		-3,456.00	0.00	1.34	4.49	42.90	6.00	0.00	-1,250.00	0.00	0.00	0.00	0.00	0.00	-80,000.00	0.00	2.00	0.00		-3,456.00	0.00		
51	0.00	-40,000.00	0.00		-3,456.00	0.00	1.34	4.49	42.90	6.00	0.00	-1,250.00	0.00	0.00	0.00	0.00	0.00	-80,000.00	0.00	2.00	0.00		-3,456.00	0.00		
52	-71,795.86	-40,000.00	-40,000.00		-3,456.00	-3,456.00	1.34	4.00	38.24	6.00	-4,016.27	-1,250.00	-1,250.00	-1,250.00	-5,005.67	-67,549.87	-80,000.00	-5,005.67	2.00	0.00	-10,011.35		-3,456.00	-3,456.00		
53	-46,185.05	-40,000.00	-40,000.00		-3,456.00	-3,456.00	1.34	3.62	34.55	6.00	-2,859.49	-1,250.00	-1,250.00	-1,250.00	-4,522.70	-43,453.67	-80,000.00	-4,522.70	2.00	0.00	-9,043.41		-3,456.00	-3,456.00		
54	0.00	-40,000.00	0.00		-3,456.00	0.00	1.34	3.67	35.07	6.00	0.00	-1,250.00	0.00	0.00	0.00	0.00	0.00	-80,000.00	0.00	2.00	0.00		-3,456.00	0.00		
55	0.00	-40,000.00	0.00		-3,456.00	0.00	1.34	4.28	40.87	6.00	0.00	-1,250.00	0.00	0.00	0.00	0.00	0.00	-80,000.00	0.00	2.00	0.00		-3,456.00	0.00		
56	0.00	-40,000.00	0.00		-3,456.00	0.00	1.34	4.36	41.64	6.00	0.00	-1,250.00	0.00	0.00	0.00	0.00	0.00	-80,000.00	0.00	2.00	0.00		-3,456.00	0.00		
57	0.00	-40,000.00	0.00		-3,456.00	0.00	1.34	4.55	43.47	6.00	0.00	-1,250.00	0.00	0.00	0.00	0.00	0.00	-80,000.00	0.00	2.00	0.00		-3,456.00	0.00		
58	0.00	-40,000.00	0.00		-3,456.00	0.00	1.34	5.02	47.94	6.00	0.00	-1,250.00	0.00	0.00	0.00	0.00	0.00	-80,000.00	0.00	2.00	0.00		-3,456.00	0.00		
59	0.00	-40,000.00	0.00		-3,456.00	0.00	1.34	5.09	48.82	6.00	0.00	-1,250.00	0.00	0.00	0.00	0.00	0.00	-80,000.00	0.00	2.00	0.00		-3,456.00	0.00		
60	0.00	-40,000.00	0.00		-3,456.00	0.00	1.34	5.09	48.82	6.00	0.00	-1,250.00	0.00	0.00	0.00	0.00	0.00	-80,000.00	0.00	2.00	0.00		-3,456.00	0.00		
61	0.00	-40,000.00	0.00		-3,456.00	0.00	1.34	5.16	49.28	6.00	0.00	-1,250.00	0.00	0.00	0.00	0.00	0.00	-80,000.00	0.00	2.00	0.00		-3,456.00	0.00		
62	0.00	-40,000.00	0.00		-3,456.00	0.00	1.34	5.62	53.69	6.00	0.00	-1,250.00	0.00	0.00	0.00	0.00	0.00	-80,000.00	0.00	2.00	0.00		-3,456.00	0.00		
63	0.00	-40,000.00	0.00		-3,456.00	0.00	1.34	6.15	58.75	6.00	0.00	-1,250.00	0.00	0.00	0.00	0.00	0.00	-80,000.00	0.00	2.00	0.00		-3,456.00	0.00		
64	-41,055.53	-40,000.00	-40,000.00		-3,456.00	-3,456.00	1.34	5.87	56.06	6.00	-1,566.64	-1,250.00	-1,250.00	-1,250.00	-7,338.16	-38,627.51	-80,000.00	-7,338.16	2.00	0.00	-14,676.32		-3,456.00	-3,456.00		
65	-80,631.57	-40,000.00	-40,000.00		-3,456.00	-3,456.00	1.34	5.43	51.88	6.00	-3,324.47	-1,250.00	-1,250.00	-1,250.00	-6,791.54	-75,863.04	-80,000.00	-6,791.54	2.00	0.00	-13,583.09		-3,456.00	-3,456.00		
66	0.00	-40,000.00	0.00		-3,456.00	0.00	1.34	5.39	51.43	6.00	0.00	-1,250.00	0.00	0.00	0.00	0.00	0.00	-80,000.00	0.00	2.00	0.00		-3,456.00	0.00		
67	-39,309.74	-40,000.00	-39,309.74		-3,456.00	-3,456.00	1.34	5.09	48.62	6.00	-1,729.44	-1,250.00	-1,250.00	-1,250.00	-6,364.73	-36,984.97	-80,000.00	-6,364.73	2.00	0.00	-12,729.46		-3,456.00	-3,456.00		
68	-14,903.30	-40,000.00	-14,903.30		-3,456.00	-3,456.00	1.34	4.89	46.74	6.00	-882.16	-1,250.00	-1,250.00	-1,250.00	-682.16	-3,338.55	-14,021.92	-80,000.00	-3,338.55	2.00	0.00	-6,677.10		-3,456.00	-3,456.00	
69	-59,608.52	-40,000.00	-40,000.00		-3,456.00	-3,456.00	1.34	4.49	42.90	6.00	-2,972.16	-1,250.00	-1,250.00	-1,250.00	-5,615.94	-56,083.28	-80,000.00	-5,615.94	2.00	0.00	-11,231.88		-3,456.00	-3,456.00		
70	0.00	-40,000.00	0.00		-3,456.00	0.00	1.34	4.49	42.90	6.00	0.00	-1,250.00	0.00	0.00	0.00	0.00	0.00	-80,000.00	0.00	2.00	0.00		-3,456.00	0.00		
71	0.00	-40,000.00	0.00		-3,456.00	0.00	1.34	4.49	42.90	6.00	0.00	-1,250.00	0.00	0.00	0.00	0.00	0.00	-80,000.00	0.00	2.00	0.00		-3,456.00	0.00		
72	0.00	-40,000.00	0.00		-3,456.00	0.00	1.34	4.78	45.65	6.00	0.00	-1,250.00	0.00	0.00	0.00	0.00	0.00	-80,000.00	0.00	2.00	0.00		-3,456.00	0.00		
73	-191,283.81	-40,000.00	-40,000.00		-3,456.00	-3,456.00	1.34	3.70	35.32	6.00	-11,584.20	-1,250.00	-1,250.00	-1,250.00	-4,623.79	-179,971.33	-80,000.00	-4,623.79	2.00	0.00	-9,247.58		-3,456.00	-3,456.00		
74	0.00	-40,000.00	0.00		-3,456.00	0.00	1.34	4.58	43.70	6.00	0.00	-1,250.00	0.00	0.00	0.00	0.00	0.00	-80,000.00	0.00	2.00	0.00		-3,456.00	0.00		
75	-35,573.41	-40,000.00	-35,573.41		-3,456.00	-3,456.00	1.34	4.27	40.81	6.00	-1,864.47	-1,250.00	-1,250.00	-1,250.00	-5,342.63	-33,469.61	-80,000.00	-5,342.63	2.00	0.00	-10,685.26		-3,456.00	-3,456.00		
76	-76,992.28	-40,000.00	-40,000.00		-3,456.00	-3,456.00	1.34	3.77	36.01	6.00	-4,217.35	-1,250.00	-1,250.00	-1,250.00	-4,713.85	-66,793.79	-80,000.00	-4,713.85	2.00	0.00	-9,427.29		-3,456.00	-3,456.00		
77	0.00	-40,000.00	0.00		-3,456.00	0.00	1.34	3.67	35.04	6.00	0.00	-1,250.00	0.00	0.00	0.00	0.00	0.00	-80,000.00	0.00	2.00	0.00		-3,456.00	0.00		
78	-116,923.98	-40,000.00	-40,000.00		-3,456.00	-3,456.00	1.34	2.78	26.54	6.00	-9,423.46	-1,250.00	-1,250.00	-1,250.00	-3,474.39	-110,009.13	-80,000.00	-3,474.39	2.00	0.00	-6,948.79		-3,456.00	-3,456.00		
79	-31,553.64	-40,000.00	-31,553.64		-3,456.00	-3,456.00	1.34	2.40	22.88	6.00	-2,949.95	-1,250.00	-1,250.00	-1,250.00	-2,995.17	-29,687.56	-80,000.00	-2,995.17	2.00	0.00	-5,990.34		-3,456.00	-3,456.00		
80	0.00	-40,000.00	0.00		-3,456.00	0.00	1.34	2.40	22.88	6.00	0.00	-1,250.00	0.00	0.00	0.00	0.00	0.00	-80,000.00	0.00	2.00	0.00		-3,456.00	0.00		
81	0.00	-40,000.00	0.00		-3,456.00	0.00	1.34	2.51	23.97	6.00	0.00	-1,250.00	0.00	0.00	0.00	0.00	0.00	-80,000.00	0.00	2.00	0.00		-3,456.00	0.00		
82	0.00	-40,000.00	0.00		-3,456.00	0.00	1.34	2.85	27.26	6.00	0.00	-1,250.00	0.00	0.00	0.00	0.00	0.00	-80,000.00	0.00	2.00	0.00		-3,456.00	0.00		
83	0.00	-40,000.00	0.00		-3,456.00	0.00	1.34	3.20	30.58	6.00	0.00	-1,250.00	0.00	0.00	0.00	0.00	0.00	-80,000.00	0.00	2.00	0.00		-3,456.00	0.00		
84	0.00	-40,000.00	0.00		-3,456.00	0.00	1.34	3.29	31.46	6.00	0.00	-1,250.00	0.00	0.00	0.00	0.00	0.00	-80,000.00	0.00	2.00	0.00		-3,456.00	0.00		
85	-67,191.89	-40,000.00	-40,000.00		-3,456.00	-3,456.00	1.34	2.70	25.74	6.00	-5,583.79	-1,250.00	-1,250.00	-1,250.00	-3,369.56	-63,218.17	-80,000.00	-3,369.56	2.00	0.00	-6,739.13		-3,456.00	-3,456.00		
86	0.00	-40,000.00	0.00		-3,456.00	0.00	1.34	2.70	25.74	6.00	0.00	-1,250.00	0.00	0.00	0.00	0.00	0.00	-80,000.00	0.00	2.00	0.00		-3,456.00	0.00		
1065																										
1066			-5,999,990.10 joules			648,031.04 joules				165.89																
1067			-235.85 Amps			-																				

	A	B	D	E	F	G	H	I	J	K	L	M	N	O	P	Q	R	S	T	U	V		
1	HUDDSCOL HDUDDS - Urban Dynamometer Driving Schedule for																						
2	Heavy Duty Vehicles										Ideal		Gravel		RR Power			Frontal		Drag Power		W/Drag	
3	Test Time, secs	Vehicle Speed, mph	m/sec	Veh Mass	Energy	Δ E	Δ E Accel	Δ E Decel	Coeff RR	Grav Constant	Veh Weight	RR Force	P _{rr}	Area	Air Density	Coeff Drag	Drag Force	P _d		Δ E Decel			
41	37.00	10.08	4.51	69,260.00	703,179.70	132,599.16	132,599.16	0.00	0.02	9.81	679,440.60	13,588.81	61,233.40	8.79	1.20	0.76	81.40	366.80		0.00			
42	38.00	11.24	5.02	69,260.00	874,335.04	171,155.34	171,155.34	0.00	0.02	9.81	679,440.60	13,588.81	68,280.11	8.79	1.20	0.76	101.21	508.57		0.00			
43	39.00	12.79	5.72	69,260.00	1,132,104.06	257,769.03	257,769.03	0.00	0.02	9.81	679,440.60	13,588.81	77,695.96	8.79	1.20	0.76	131.05	749.31		0.00			
44	40.00	14.00	6.26	69,260.00	1,356,442.32	224,338.26	224,338.26	0.00	0.02	9.81	679,440.60	13,588.81	85,046.40	8.79	1.20	0.76	157.02	982.73		0.00			
45	41.00	15.58	6.98	69,260.00	1,645,233.05	-261,209.27	0.00	-261,209.27	0.02	9.81	679,440.60	13,588.81	76,420.26	8.79	1.20	0.76	126.78	713.01		-184,076.00			
46	42.00	17.22	7.75	69,260.00	1,999,310.72	51,077.67	51,077.67	0.00	0.02	9.81	679,440.60	13,588.81	78,181.94	8.79	1.20	0.76	132.70	763.46		0.00			
47	43.00	19.00	8.51	69,260.00	2,409,585.47	23,274.75	23,274.75	0.00	0.02	9.81	679,440.60	13,588.81	78,971.65	8.79	1.20	0.76	135.39	786.83		0.00			
48	44.00	20.88	9.30	69,260.00	2,882,060.24	0.00	0.00	0.00	0.02	9.81	679,440.60	13,588.81	78,971.65	8.79	1.20	0.76	135.39	786.83		0.00			
49	45.00	22.80	10.15	69,260.00	3,415,545.01	125,556.73	125,556.73	0.00	0.02	9.81	679,440.60	13,588.81	83,102.48	8.79	1.20	0.76	149.93	916.88		0.00			
50	46.00	24.84	11.00	69,260.00	3,999,020.78	261,998.22	261,998.22	0.00	0.02	9.81	679,440.60	13,588.81	91,121.14	8.79	1.20	0.76	180.26	1,208.72		0.00			
51	47.00	26.94	11.93	69,260.00	4,632,495.55	0.00	0.00	0.00	0.02	9.81	679,440.60	13,588.81	91,121.14	8.79	1.20	0.76	180.26	1,208.72		0.00			
52	48.00	29.16	12.90	69,260.00	5,315,970.32	-320,031.11	0.00	-320,031.11	0.02	9.81	679,440.60	13,588.81	81,219.31	8.79	1.20	0.76	143.21	855.95		-237,955.86			
53	49.00	31.50	13.90	69,260.00	6,049,445.09	-227,207.55	0.00	-227,207.55	0.02	9.81	679,440.60	13,588.81	73,382.89	8.79	1.20	0.76	116.91	631.32		-153,193.34			
54	50.00	33.96	14.93	69,260.00	6,832,920.86	30,320.64	30,320.64	0.00	0.02	9.81	679,440.60	13,588.81	74,476.34	8.79	1.20	0.76	120.42	659.97		0.00			
55	51.00	36.54	16.00	69,260.00	7,666,395.63	372,997.42	372,997.42	0.00	0.02	9.81	679,440.60	13,588.81	86,808.07	8.79	1.20	0.76	163.59	1,045.08		0.00			
56	52.00	39.24	17.15	69,260.00	8,549,870.40	53,908.20	53,908.20	0.00	0.02	9.81	679,440.60	13,588.81	88,448.25	8.79	1.20	0.76	169.84	1,105.44		0.00			
57	53.00	42.06	18.36	69,260.00	9,483,345.17	131,812.97	131,812.97	0.00	0.02	9.81	679,440.60	13,588.81	92,336.09	8.79	1.20	0.76	185.09	1,257.72		0.00			
58	54.00	45.00	19.63	69,260.00	10,466,820.94	345,045.71	345,045.71	0.00	0.02	9.81	679,440.60	13,588.81	101,812.68	8.79	1.20	0.76	225.04	1,686.06		0.00			
59	55.00	48.06	21.66	69,260.00	11,500,295.71	56,073.66	56,073.66	0.00	0.02	9.81	679,440.60	13,588.81	103,270.62	8.79	1.20	0.76	231.53	1,759.54		0.00			
60	56.00	51.24	23.34	69,260.00	12,583,770.48	0.00	0.00	0.00	0.02	9.81	679,440.60	13,588.81	103,270.62	8.79	1.20	0.76	231.53	1,759.54		0.00			
61	57.00	54.54	25.15	69,260.00	13,717,245.25	54,485.38	54,485.38	0.00	0.02	9.81	679,440.60	13,588.81	104,667.81	8.79	1.20	0.76	237.84	1,831.93		0.00			
62	58.00	57.96	26.58	69,260.00	14,900,720.02	383,679.40	383,679.40	0.00	0.02	9.81	679,440.60	13,588.81	114,022.92	8.79	1.20	0.76	282.25	2,368.34		0.00			
63	59.00	61.50	28.13	69,260.00	16,134,194.79	481,528.03	481,528.03	0.00	0.02	9.81	679,440.60	13,588.81	124,775.21	8.79	1.20	0.76	337.99	3,103.51		0.00			
64	60.00	65.16	29.85	69,260.00	17,417,669.56	-261,126.22	0.00	-261,126.22	0.02	9.81	679,440.60	13,588.81	119,064.95	8.79	1.20	0.76	307.76	2,696.62		-139,364.64			
65	61.00	68.94	31.65	69,260.00	18,751,144.33	-381,329.16	0.00	-381,329.16	0.02	9.81	679,440.60	13,588.81	110,195.83	8.79	1.20	0.76	263.62	2,137.78		-268,995.54			
66	62.00	72.84	33.52	69,260.00	20,134,619.10	-39,995.67	0.00	-39,995.67	0.02	9.81	679,440.60	13,588.81	109,223.87	8.79	1.20	0.76	258.99	2,081.71		0.00			
67	63.00	76.86	35.49	69,260.00	21,568,093.87	-237,241.76	0.00	-237,241.76	0.02	9.81	679,440.60	13,588.81	103,270.62	8.79	1.20	0.76	231.53	1,759.54		-132,211.60			
68	64.00	80.98	37.53	69,260.00	23,051,568.64	-152,284.18	0.00	-152,284.18	0.02	9.81	679,440.60	13,588.81	99,261.29	8.79	1.20	0.76	213.90	1,562.46		-51,460.43			
69	65.00	85.22	39.63	69,260.00	24,585,043.41	-290,635.76	0.00	-290,635.76	0.02	9.81	679,440.60	13,588.81	91,121.14	8.79	1.20	0.76	180.26	1,208.72		-198,305.90			
70	66.00	89.58	41.78	69,260.00	26,168,518.18	0.00	0.00	0.00	0.02	9.81	679,440.60	13,588.81	91,121.14	8.79	1.20	0.76	180.26	1,208.72		0.00			
71	67.00	94.06	43.97	69,260.00	27,802,093.95	0.00	0.00	0.00	0.02	9.81	679,440.60	13,588.81	91,121.14	8.79	1.20	0.76	180.26	1,208.72		0.00			
72	68.00	98.66	46.20	69,260.00	29,485,568.72	205,692.02	205,692.02	0.00	0.02	9.81	679,440.60	13,588.81	96,952.89	8.79	1.20	0.76	204.07	1,455.96		0.00			
73	69.00	103.38	48.48	69,260.00	31,219,043.49	-707,281.55	0.00	-707,281.55	0.02	9.81	679,440.60	13,588.81	75,023.07	8.79	1.20	0.76	122.19	674.61		-631,583.87			
74	70.00	108.22	50.81	69,260.00	33,002,518.26	560,265.35	560,265.35	0.00	0.02	9.81	679,440.60	13,588.81	92,822.07	8.79	1.20	0.76	187.05	1,277.68		0.00			
75	71.00	113.18	53.19	69,260.00	34,836,093.03	-206,549.49	0.00	-206,549.49	0.02	9.81	679,440.60	13,588.81	86,686.58	8.79	1.20	0.76	163.14	1,040.70		-118,822.21			
76	72.00	118.26	55.62	69,260.00	36,719,567.80	-312,291.78	0.00	-312,291.78	0.02	9.81	679,440.60	13,588.81	76,481.01	8.79	1.20	0.76	126.99	714.71		-235,096.06			
77	73.00	123.46	58.10	69,260.00	38,653,042.57	-58,448.82	0.00	-58,448.82	0.02	9.81	679,440.60	13,588.81	74,415.60	8.79	1.20	0.76	120.22	658.35		0.00			
78	74.00	128.76	60.63	69,260.00	40,636,517.34	-442,533.08	0.00	-442,533.08	0.02	9.81	679,440.60	13,588.81	56,373.61	8.79	1.20	0.76	68.99	286.22		-385,873.25			
79	75.00	134.16	63.21	69,260.00	42,669,992.11	-153,073.13	0.00	-153,073.13	0.02	9.81	679,440.60	13,588.81	48,597.94	8.79	1.20	0.76	51.27	183.37		-104,291.82			
80	76.00	139.66	65.82	69,260.00	44,753,466.88	0.00	0.00	0.00	0.02	9.81	679,440.60	13,588.81	48,597.94	8.79	1.20	0.76	51.27	183.37		0.00			
81	77.00	145.26	68.47	69,260.00	46,886,941.65	43,076.73	43,076.73	0.00	0.02	9.81	679,440.60	13,588.81	50,906.34	8.79	1.20	0.76	56.26	210.76		0.00			
82	78.00	150.96	71.15	69,260.00	49,070,416.42	142,540.63	142,540.63	0.00	0.02	9.81	679,440.60	13,588.81	57,892.30	8.79	1.20	0.76	72.76	309.98		0.00			
83	79.00	156.76	73.88	69,260.00	51,303,891.19	162,324.62	162,324.62	0.00	0.02	9.81	679,440.60	13,588.81	64,939.00	8.79	1.20	0.76	91.55	437.51		0.00			
84	80.00	162.66	76.63	69,260.00	53,587,365.96	837,395.52	837,395.52	0.00	0.02	9.81	679,440.60	13,588.81	66,822.17	8.79	1.20	0.76	96.94	476.68		0.00			
85	81.00	168.66	79.42	69,260.00	55,920,840.73	-276,824.96	0.00	-276,824.96	0.02	9.81	679,440.60	13,588.81	54,672.68	8.79	1.20	0.76	64.89	261.08					

	AD	AE	AF	AG	AH	AI	AJ	AQ	AR	AS	AU	AV	AW	AX	AY	AZ	BA	BB	BC	BD	BE	BF	BG	BH	BI	
1		Drive Train Regen			Existing Armasafe Batteries (4 Batteries in Parallel w/ max current of 1,728 /sec (ea))							In-Wheel Regen											Existing Armasafe Batteries (4 Batteries in Parallel w/ max current of 1,728 /sec (ea))			
2	Power Avail @ 74.4% 93% eff of the Drive Train Regen & 80% eff at the Torque Converter	40000W		Joules/sec				m								Power Avail 70% eff from each In-Wheel Regen	80000W Peak Gen Power based off # of Wheels	Single-Wheel			LVSR		Joules/sec			
3			Drive Train Regen		Max Current	Max Stored		Tire Dia	Angle Vel	Wh rpm	Num of Wheels	Torque	Max Torque	Usable Torque	Max Power w/Lim Torque			In Wheel Regen		Number of Motor Wheels	In Wheel Regen		Max Current	Max Stored		
42	0.00	-40,000.00	0.00		-6,912.00	0.00		1.34	3.37	32.15	10.00	0.00	-1,250.00	0.00	0.00	0.00	-80,000.00	0.00		4.00	0.00		-6,912.00	0.00		
43	0.00	-40,000.00	0.00		-6,912.00	0.00		1.34	3.83	36.58	10.00	0.00	-1,250.00	0.00	0.00	0.00	-80,000.00	0.00		4.00	0.00		-6,912.00	0.00		
44	0.00	-40,000.00	0.00		-6,912.00	0.00		1.34	4.19	40.04	10.00	0.00	-1,250.00	0.00	0.00	0.00	-80,000.00	0.00		4.00	0.00		-6,912.00	0.00		
45	-136,952.54	-40,000.00	-40,000.00		-6,912.00	-6,912.00		1.34	3.77	35.98	10.00	-4,885.35	-1,250.00	-1,250.00	-4,709.90	-128,853.20	-80,000.00	-4,709.90		4.00	-18,839.61		-6,912.00	-6,912.00		
46	0.00	-40,000.00	0.00		-6,912.00	0.00		1.34	3.85	36.81	10.00	0.00	-1,250.00	0.00	0.00	0.00	-80,000.00	0.00		4.00	0.00		-6,912.00	0.00		
47	0.00	-40,000.00	0.00		-6,912.00	0.00		1.34	3.89	37.18	10.00	0.00	-1,250.00	0.00	0.00	0.00	-80,000.00	0.00		4.00	0.00		-6,912.00	0.00		
48	0.00	-40,000.00	0.00		-6,912.00	0.00		1.34	3.89	37.18	10.00	0.00	-1,250.00	0.00	0.00	0.00	-80,000.00	0.00		4.00	0.00		-6,912.00	0.00		
49	0.00	-40,000.00	0.00		-6,912.00	0.00		1.34	4.10	39.13	10.00	0.00	-1,250.00	0.00	0.00	0.00	-80,000.00	0.00		4.00	0.00		-6,912.00	0.00		
50	0.00	-40,000.00	0.00		-6,912.00	0.00		1.34	4.49	42.90	10.00	0.00	-1,250.00	0.00	0.00	0.00	-80,000.00	0.00		4.00	0.00		-6,912.00	0.00		
51	0.00	-40,000.00	0.00		-6,912.00	0.00		1.34	4.49	42.90	10.00	0.00	-1,250.00	0.00	0.00	0.00	-80,000.00	0.00		4.00	0.00		-6,912.00	0.00		
52	-177,039.16	-40,000.00	-40,000.00		-6,912.00	-6,912.00		1.34	4.00	38.24	10.00	-5,942.15	-1,250.00	-1,250.00	-5,005.67	-166,569.10	-80,000.00	-5,005.67		4.00	-20,022.70		-6,912.00	-6,912.00		
53	-113,975.84	-40,000.00	-40,000.00		-6,912.00	-6,912.00		1.34	3.62	34.55	10.00	-4,234.01	-1,250.00	-1,250.00	-4,522.70	-107,235.33	-80,000.00	-4,522.70		4.00	-18,090.81		-6,912.00	-6,912.00		
54	0.00	-40,000.00	0.00		-6,912.00	0.00		1.34	3.67	35.07	10.00	0.00	-1,250.00	0.00	0.00	0.00	-80,000.00	0.00		4.00	0.00		-6,912.00	0.00		
55	0.00	-40,000.00	0.00		-6,912.00	0.00		1.34	4.28	40.87	10.00	0.00	-1,250.00	0.00	0.00	0.00	-80,000.00	0.00		4.00	0.00		-6,912.00	0.00		
56	0.00	-40,000.00	0.00		-6,912.00	0.00		1.34	4.38	41.64	10.00	0.00	-1,250.00	0.00	0.00	0.00	-80,000.00	0.00		4.00	0.00		-6,912.00	0.00		
57	0.00	-40,000.00	0.00		-6,912.00	0.00		1.34	4.55	43.47	10.00	0.00	-1,250.00	0.00	0.00	0.00	-80,000.00	0.00		4.00	0.00		-6,912.00	0.00		
58	0.00	-40,000.00	0.00		-6,912.00	0.00		1.34	5.02	47.94	10.00	0.00	-1,250.00	0.00	0.00	0.00	-80,000.00	0.00		4.00	0.00		-6,912.00	0.00		
59	0.00	-40,000.00	0.00		-6,912.00	0.00		1.34	5.09	48.62	10.00	0.00	-1,250.00	0.00	0.00	0.00	-80,000.00	0.00		4.00	0.00		-6,912.00	0.00		
60	0.00	-40,000.00	0.00		-6,912.00	0.00		1.34	5.09	48.62	10.00	0.00	-1,250.00	0.00	0.00	0.00	-80,000.00	0.00		4.00	0.00		-6,912.00	0.00		
61	0.00	-40,000.00	0.00		-6,912.00	0.00		1.34	5.16	49.28	10.00	0.00	-1,250.00	0.00	0.00	0.00	-80,000.00	0.00		4.00	0.00		-6,912.00	0.00		
62	0.00	-40,000.00	0.00		-6,912.00	0.00		1.34	5.62	53.69	10.00	0.00	-1,250.00	0.00	0.00	0.00	-80,000.00	0.00		4.00	0.00		-6,912.00	0.00		
63	0.00	-40,000.00	0.00		-6,912.00	0.00		1.34	6.15	58.75	10.00	0.00	-1,250.00	0.00	0.00	0.00	-80,000.00	0.00		4.00	0.00		-6,912.00	0.00		
64	-103,687.39	-40,000.00	-40,000.00		-6,912.00	-6,912.00		1.34	5.87	56.06	10.00	-2,373.97	-1,250.00	-1,250.00	-7,338.16	-97,555.25	-80,000.00	-7,338.16		4.00	-29,352.65		-6,912.00	-6,912.00		
65	-200,132.68	-40,000.00	-40,000.00		-6,912.00	-6,912.00		1.34	5.43	51.88	10.00	-4,950.93	-1,250.00	-1,250.00	-6,791.54	-188,296.88	-80,000.00	-6,791.54		4.00	-27,166.17		-6,912.00	-6,912.00		
66	0.00	-40,000.00	0.00		-6,912.00	0.00		1.34	5.39	51.43	10.00	0.00	-1,250.00	0.00	0.00	0.00	-80,000.00	0.00		4.00	0.00		-6,912.00	0.00		
67	-98,365.43	-40,000.00	-40,000.00		-6,912.00	-6,912.00		1.34	5.09	48.62	10.00	-2,596.57	-1,250.00	-1,250.00	-6,364.73	-92,548.12	-80,000.00	-6,364.73		4.00	-25,458.93		-6,912.00	-6,912.00		
68	-38,286.56	-40,000.00	-38,286.56		-6,912.00	-6,912.00		1.34	4.89	46.74	10.00	-1,051.48	-1,250.00	-1,051.48	-5,146.04	-36,022.30	-80,000.00	-5,146.04		4.00	-20,584.17		-6,912.00	-6,912.00		
69	-147,539.59	-40,000.00	-40,000.00		-6,912.00	-6,912.00		1.34	4.49	42.90	10.00	-4,413.91	-1,250.00	-1,250.00	-5,615.94	-138,814.13	-80,000.00	-5,615.94		4.00	-22,463.76		-6,912.00	-6,912.00		
70	0.00	-40,000.00	0.00		-6,912.00	0.00		1.34	4.49	42.90	10.00	0.00	-1,250.00	0.00	0.00	0.00	-80,000.00	0.00		4.00	0.00		-6,912.00	0.00		
71	0.00	-40,000.00	0.00		-6,912.00	0.00		1.34	4.49	42.90	10.00	0.00	-1,250.00	0.00	0.00	0.00	-80,000.00	0.00		4.00	0.00		-6,912.00	0.00		
72	0.00	-40,000.00	0.00		-6,912.00	0.00		1.34	4.78	45.65	10.00	0.00	-1,250.00	0.00	0.00	0.00	-80,000.00	0.00		4.00	0.00		-6,912.00	0.00		
73	-469,896.40	-40,000.00	-40,000.00		-6,912.00	-6,912.00		1.34	3.70	35.32	10.00	-17,074.30	-1,250.00	-1,250.00	-4,623.79	-442,108.71	-80,000.00	-4,623.79		4.00	-18,495.16		-6,912.00	-6,912.00		
74	0.00	-40,000.00	0.00		-6,912.00	0.00		1.34	4.58	43.70	10.00	0.00	-1,250.00	0.00	0.00	0.00	-80,000.00	0.00		4.00	0.00		-6,912.00	0.00		
75	-88,403.73	-40,000.00	-40,000.00		-6,912.00	-6,912.00		1.34	4.27	40.81	10.00	-2,780.05	-1,250.00	-1,250.00	-5,342.63	-83,175.55	-80,000.00	-5,342.63		4.00	-21,370.52		-6,912.00	-6,912.00		
76	-174,911.47	-40,000.00	-40,000.00		-6,912.00	-6,912.00		1.34	3.77	36.01	10.00	-6,234.45	-1,250.00	-1,250.00	-4,713.65	-164,567.24	-80,000.00	-4,713.65		4.00	-18,854.58		-6,912.00	-6,912.00		
77	0.00	-40,000.00	0.00		-6,912.00	0.00		1.34	3.67	35.04	10.00	0.00	-1,250.00	0.00	0.00	0.00	-80,000.00	0.00		4.00	0.00		-6,912.00	0.00		
78	-287,089.70	-40,000.00	-40,000.00		-6,912.00	-6,912.00		1.34	2.78	26.54	10.00	-13,882.75	-1,250.00	-1,250.00	-3,474.39	-270,111.28	-80,000.00	-3,474.39		4.00	-13,897.58		-6,912.00	-6,912.00		
79	-77,593.12	-40,000.00	-40,000.00		-6,912.00	-6,912.00		1.34	2.40	22.88	10.00	-4,352.50	-1,250.00	-1,250.00	-2,995.17	-73,004.28	-80,000.00	-2,995.17		4.00	-11,980.67		-6,912.00	-6,912.00		
80	0.00	-40,000.00	0.00		-6,912.00	0.00		1.34	2.40	22.88	10.00	0.00	-1,250.00	0.00	0.00	0.00	-80,000.00	0.00		4.00	0.00		-6,912.00	0.00		
81	0.00	-40,000.00	0.00		-6,912.00	0.00		1.34	2.51	23.97	10.00	0.00	-1,250.00	0.00	0.00	0.00	-80,000.00	0.00		4.00	0.00		-6,912.00	0.00		
82	0.00	-40,000.00	0.00		-6,912.00	0.00		1.34	2.85	27.28	10.00	0.00	-1,250.00	0.00	0.00	0.00	-80,000.00	0.00		4.00	0.00		-6,912.00	0.00		
83	0.00	-40,000.00	0.00		-6,912.00	0.00		1.34	3.20	30.58	10.00	0.00	-1,250.00	0.00	0.00	0.00	-80,000.00	0.00		4.00	0.00		-6,912.00	0.00		
84	0.00	-40,000.00	0.00		-6,912.00	0.00		1.34	3.29	31.46	10.00	0.00	-1,250.00	0.00	0.00	0.00	-80,000.00	0.00		4.00	0.00		-6,912.00	0.00		
85	-165,087.05	-40,000.00	-40,000.00		-6,912.00	-6,912.00		1.34	2.70	25.74	10.00	-8,231.45	-1,250.00	-1,250.00	-3,369.56	-155,323.84	-80,000.00	-3,369.56		4.00	-13,478.26		-6,912.00	-6,912.00		
86	0.00	-40,000.00	0.00		-6,912.00	0.00		1.34	2.70	25.74	10.00	0.00	-1,250.00	0.00	0.00	0.00	-80,000.00	0.00		4.00	0.00		-6,912.00	0.00		
1065																										
1066			-7,029,034.16	joules		-1,326,591.08	joules			165.89								-1,370,523.96	joules			-5,482,091.44	joules		-1,213,246.92	joules
1067			-276.30	Amps		-52.15	Amps												-53.87	Amps			-215.49	Amps	</	

THIS PAGE INTENTIONALLY LEFT BLANK

APPENDIX B. BATTERY SPECIFICATIONS

Tables 29 and 30 provide the numbers and calculations performed to show how much energy the APU was able to effectively capture for follow-on use for the MTRV and LVSR, respectively. These calculations were performed bearing in mind the APU has an internal resistance of 5%. These values were ultimately used to calculate the break-even point for each of the upgrades.

Table 29. MTRV APU energy capture calculations

MTRV	6T Li Batt 24V DC (99 AmpHrs ea)		
	Amp Captured	396	198
	60 min DP	Amp Hrs	AmpHrs
	0.95	Qty 4	Qty 2
	Energy loss	Avail Amp Hrs	
Drive Train Regen Brake	393.56	373.88	
In Wheel Regen Brake (2 Wheel)	260.82	247.78	
In Wheel Regen Brake (4 Wheel)	343.62	326.44	
Solar Panel (440W 2x4x12)	51.33		48.77

Table 30. LVSR APU energy capture calculations

LVSR	6T Li Batt 24V DC (99 AmpHrs ea)		
	Amp Captured	396	198
	60 min DP	Amp Hrs	AmpHrs
	0.95	Qty 4	Qty 2
	Energy loss	Avail Amp Hrs	
Drive Train Regen Brake	431.32	376.20	
In Wheel Regen Brake (4 Wheel)	361.52	343.45	
In Wheel Regen Brake (6 Wheel)	388.02	368.62	
Solar Panel (440W 2x4x12)	51.33		48.77

THIS PAGE INTENTIONALLY LEFT BLANK

LIST OF REFERENCES

- Advance Policy Questions for James N. Mattis, Nominee to be Secretary of Defense*, 115th Cong. (2017) (testimony of James N. Mattis, USMC General [ret.]).
- Allison Transmission. (2016). *Allison hybrids deliver advanced technology and proven reliability*. Indianapolis, IN: Author
- Alvarez, S. (2018, September 12). Tesla semi production to ‘earnestly’ begin by 2020. Retrieved from <https://www.teslarati.com/tesla-semi-production-2020/>
- Amazon.com. (2018). Maxwell Technologies ESM Ultra 31/1800 Ultracapacitor Engine start module. Retrieved from <https://www.amazon.com/Maxwell-ULTRA31-Engine-Starting-Battery/dp/B00WT75NG8>
- Battery University. (2018). BU-902: How to measure internal resistance. Retrieved from https://batteryuniversity.com/learn/article/how_to_measure_internal_resistance
- Bedford, A. & Fowler, W. (2004) *Engineering mechanics—Statics and dynamics* (4th ed.). Upper Saddle River, NJ: Prentice Hall.
- Bergstrom Inc. (2018). Product line brochure. Retrieved from <https://us.bergstrominc.com/>
- Bohnwagner, A. (2013). An overview of the fully burdened cost of energy (FBCE). Retrieved from Office of the Under Secretary of Defense for Acquisition, Technology, and Logistics: https://www.acq.osd.mil/eie/Downloads/OE/Energy%20FBCE_12-11-13.pdf
- Borgnakke, C. & Sonntag, R. (2012). *Fundamentals of thermodynamics* (8th ed.). Hoboken, NJ: Wiley.
- Boundy, R. G., Davis, S. C., & Williams, S. E. (2017). *Transportation energy data book: Edition 36* (No. ORNL/TM-2017/513). Oak Ridge National Lab.(ORNL), Oak Ridge, TN (United States).
- Boylan, C. (2016, May 27). A brief history of Tesla cars in one simple infographic. Retrieved from <https://cleantechnica.com/2016/05/27/brief-history-tesla-cars-one-simple-infographic/>

- Cannon, J. (2017, August 15). Do the math before ‘filling up’ your electric truck. Retrieved from <https://www.ccjdigital.com/fuzzy-math-and-figuring-out-an-electric-trucks-fuel-savings/>
- Catherino, H. A. (2006). Complexity in battery systems: Thermal runaway in VRLA batteries. *Journal of Power Sources*, 158(2), 977-986.
- Ceraolo, M., Huria, T., Pede, G., & Vellucci, F. (2011, September). Lithium-ion starting-lighting-ignition batteries: Examining the feasibility. In *Vehicle Power and Propulsion Conference (VPPC), 2011 IEEE* (pp. 1-6). IEEE.
- Chevrolet Volt. (n.d.). In *Wikipedia*. Retrieved September 26, 2018, from https://en.wikipedia.org/wiki/Chevrolet_Volt
- Choi, J., Jeong, J., Park, Y. I., & Cha, S. W. (2015). Analysis of regenerative braking effect to improve fuel economy for E-REV bus based on simulation. *World Electric Vehicle Journal*, 7(3), 366-370.
- The Clean Green Car Company (2008, February 25). Toyota Prius II battery pack. Retrieved from <https://web.archive.org/web/20080225234612/http://www.cleangreencar.co.nz/page/prius-battery-pack>
- Cruse, S., Sims, B. (2017). *Review of battery technologies for military land vehicles* (Objective ID # fAV1019728). Edinburgh SA: Australian Government Department of Defence Science and Technology
- Dahn, J., Ehrlich, G. M., & Reddy, T. B. (2011). *Linden's handbook of batteries*. by Thomas B. Reddy. 4th ed. New York: McGraw-Hill.
- Defense Acquisition University. (2010). *Defense acquisition guidebook; Dated: August 5, 2010*. Ft. Belvoir, VA: Author. Retrieved from <http://www.acqnotes.com/Attachments/Defense%20Acquisition%20Guidebook.pdf>
- Defense Acquisition University. (2017, November 2). Defense acquisition guidebook (DAG)—Foreword. Retrieved from <https://www.dau.mil/tools/dag/Pages/DAG-Page-Viewer.aspx?source=https://www.dau.mil/guidebooks/Shared%20Documents%20HTML/Foreword.aspx>

Defense Logistics Agency (n.d.) At a glance. Retrieved October 19, 2018, from <http://www.dla.mil/AtaGlance/>

Defense Logistics Agency [DLA]. (2018, March 29) Memorandum for Assistant Secretary of the Army (Financial Management and Comptroller), Assistant Secretary of the Navy (Financial Management and Comptroller), Assistant Secretary of the Air Force (Financial Management and Comptroller), Deputy Chief Management Officer, Director, Defense Finance and Accounting Service, Directors, Defense Agencies, Under Secretary of Defense, Subject: Fiscal Year (FY) 2018 Fuel Price. Retrieved from <http://www.dla.mil/Energy/Business/StandardPrices/>

Department of Defense. (2015, January 23). Chairman of the Joint Chief of Staff Instruction 3170.01I (DODI 3170.0I) Washington, DC: DOD. Retrieved from http://www.jcs.mil/Portals/36/Documents/Library/Instructions/3170_01a.pdf?ver=2016-02-05-175022-720

Department of Defense. (2001). *Military handbook—Configuration management guidance*. Washington, DC: Author. Retrieved from [http://www.acqnotes.com/Attachments/MIL-HDBK-61A%20\(SE\)Configuration%20Management%20Guidance.pdf](http://www.acqnotes.com/Attachments/MIL-HDBK-61A%20(SE)Configuration%20Management%20Guidance.pdf)

Department of Defense. (2015, January 7). *Operation of the Defense Acquisition System* (DoD Instruction 5000.02). Washington, DC: Under Secretary of Defense for Acquisition, Technology, and Logistics. Retrieved from http://www.esd.whs.mil/Portals/54/Documents/DD/issuances/dodi/500002_dodi_2015.pdf

Department of the Navy. (1998). *Maintenance operations* (MCWP 4-11.4). Washington, DC: United States Marine Corps. Retrieved from <https://www.trngcmd.marines.mil/Portals/207/Docs/TBS/MCWP%204-11.4%20Maintenance%20Operations.pdf?ver=2015-04-07-094614-640>

Department of the Navy. (2016). *Petroleum and water logistic operations* (MCRP 3-40B.5). Washington, DC: United States Marine Corps. Retrieved from <http://www.marines.mil/Portals/59/Publications/MCRP%203-40B.5.pdf?ver=2017-03-28-141021-523>

Department of the Navy. (2015, December) *System operation manual* (TM 10629A-OR/A). Quantico, VA: United States Marine Corps.

- Department of the Navy. (2015, September). *System operation manual* (TM 11313A/12481A-OD/1A). Quantico, VA: United States Marine Corps.
- Dimotakis, P., Grober, R., & Lewis, N. (2006). *Reducing DoD fossil-fuel dependence*. McLean, VA: The MITRE Corporation.
- Donovan, S. (2016, December 12). *2017 Discount rates for OMB Circular no. A-94* [Memorandum]. Washington, DC: Office of Management and Budget. M-17-10
- Duff, W. (1919). *A text-book of physics* (4th ed.). Philadelphia, PA: P. Blakiston's Son & Co.
- Eady, D. S., Siegel, S. B., Bell, S., Dicke, S. H. (2009). *Sustain the mission project: Casualty factors for fuel and water resupply convoys* (Report No. CTC-CR-2009-163). Arlington, Virginia: Army Environmental Policy Institute
- Edsall, L. (2010). *Chevrolet Volt: Charging into the future*. Minneapolis, MN: Motorbooks.
- EnergySage. (2018, April 20). How much energy does a solar panel actually produce? Retrieved from <https://news.energysage.com/what-is-the-power-output-of-a-solar-panel/>
- Engineers Edge. (2018). Air Density and Specific Weight Tables, Equations and Calculator. Retrieved from <https://www.engineersedge.com/calculators/air-density.htm>
- Environment Protection Agency (EPA). (n.d.) Vehicle and fuel emissions testing—Dynamometer drive schedules—Heavy duty urban dynamometer driving schedule (HDUDDS), Accessed on 16 July 2018 from <https://www.epa.gov/vehicle-and-fuel-emissions-testing/dynamometer-drive-schedules>
- Evans, P. (2009, March 26). Formula One KERS explained. *New atlas*. Retrieved from <http://www.motortrend.com/news/volvo-s60-flywheel-kers-prototype-first-drive/>
- Evans, P. (2009, May 7). UK team develops plug-in hybrid retrofit kit for ICE vehicle. Retrieved from <https://www.boschrexroth.com/en/us/company/press/press-details-25088>
- Farret, F. A., & Simoes, M. G. (2006). *Integration of alternative sources of energy*. Upper Saddle River, NJ: John Wiley & Sons.

- Feickert, A. (2018). *Joint light tactical vehicle (JLTV): Background and issues for Congress* (CRS Report No. RS22942). Retrieved from Congressional Research Service website: <https://fas.org/sgp/crs/weapons/RS22942.pdf>
- Flight Systems Inc. (2018). Model 277EC Engine Idle Limiter. Retrieved from <https://www.flightsystems.com/p-engine-idle-timer.html>
- Flynn, P., Rose, M. F., Brodersen, R. W., Cairns, E. J., Cheh, H. Y., & Davis, W. L. (2004). Meeting the energy needs of future warriors. *National Research Council*.
- Gallenson, A., Salem, A. (2014). *A study of human behavior & operational energy: Analysis and recommendations for the Marine Corps to increase its operational reach*. Retrieved from https://nps.primo.exlibrisgroup.com/discovery/fulldisplay?docid=alma991005398493103791&context=L&vid=01NPS_INST:01NPS&search_scope=MyInst_and_CI&tab=Everything&lang=en
- General Accounting Office (GAO). (1999, April 09). United States Military Safety: Army M939 5-Ton Truck Accident History and Planned Modifications (GAO/NSIAD-99-82) Washington, DC: GAO. Retrieved from <https://www.globalsecurity.org/military/library/report/gao/nsiad-99-082.htm>
- Gilmer, E. (2018) Cost Estimation Worksheet 9639. B, Preliminary Draft. [Excel Worksheet]. Marine Corps Logistics Base, Albany, GA: Cost Estimator, Program Management Division (PMD), Marine Depot Maintenance Command, Production Plant Albany.
- Gilroy, R. (2018, July 30). Hyliion acquires Genthem's battery division. Retrieved from <https://www.ttnews.com/articles/hyliion-acquires-genthem-battery-division>
- Gourley, S. (2012, September). Medium and heavy tactical vehicles. *PEO Land Systems*, 36-40.
- Hanley, S. (2014, December 22). 10 things To consider before you start an EV conversion. Retrieved from <https://gas2.org/2014/12/22/10-things-to-consider-before-you-start-an-ev-conversion/>
- Hawker, EnerSys. (2010). Hawker ArmaSafe Plus Brochure. Retrieved from https://www.hawkeraplus.com/why_armasafe.htm
- H.R. 5658, 110th Cong. (2009). Retrieved from <https://www.congress.gov/bill/110th-congress/house-bill/5658/text>

- Huang, C. K., Sakamoto, J. S., Wolfenstine, J., & Surampudi, S. (2000). The limits of low-temperature performance of Li-ion cells. *Journal of the Electrochemical Society*, 147(8), 2893-2896.
- Hyllion. (n.d.). Technology. Retrieved from <https://www.hyllion.com/technology/>
- InMotion. (2018). Product Information Sheet, Low Voltage Generator/Motor. Retrieved from <http://en.evs-inmotion.com/products/gsm/>
- J&M Clutch and Converter. (2018). Applications and Selection of Torque Converters. Retrieved from <http://jmclutch.com/site/book/export/html/37>
- Jane's by HIS Markit. (2016, March 28). Oshkosh Logistic Vehicle System Replacement (LVSr). Retrieved from <https://janes.ihs.com/Janes/Display/1495288>
- Jane's by IHS Markit. (2015, December 23). Oshkosh (6 x 6) Medium Tactical Vehicle Replacement (MTVR) and Trailers. Retrieved from <https://janes.ihs.com/Janes/Display/1495139>
- Joint Light Tactical Vehicle. (n.d.). In *Wikipedia*. Retrieved 14 June, 2018, from https://en.wikipedia.org/wiki/Joining_Light_Tactical_Vehicle
- Kane, M. (2018, June 24). In-wheel motor manufacturer Protean Electric secures \$40 million funding. Retrieved from <https://insideevs.com/in-wheel-motor-manufacturer-protean-electric-secured-40-million-funding/>
- Kramer, D.M., Parker, G.G. (2011). Current state of military hybrid vehicle development. *International Journal of Electric and Hybrid Vehicles*, 3(4). Retrieved from <https://pdfs.semanticscholar.org/08db/d3d0b50aac7974e76214337c55db5746a750.pdf>
- Lamothe, D. (2009, October 22) First LVSr truck arrives in Afghanistan. *Marine Corps Times*. Gannett Company. Retrieved from http://www.marinecorpstimes.com/news/2009/10/marine_lvsr_102209w/
- Larson, C.E., Whitt, R. E. (2013). *Fully burdened cost of energy analysis: A model for Marine Corps systems* (Master's thesis). Retrieved from <https://calhoun.nps.edu/handle/10945/32920>
- Mattis, J. (2018). *Summary of the 2018 National Defense Strategy of The United States of America: Sharpening the American military's competitive edge*. Washington DC: Department of Defense.

- Mayersohn, N. (2010, October 15). Sorting myth from fact as Volt makes its debut. *New York Times*. Retrieved from https://www.nytimes.com/2010/10/17/automobiles/17VOLT.html?_r=1&scp=1&sq=Chevy%20Volt&st=cse
- McFarland, K. (10 May 2018). Former United States Assistant Secretary of the Army for Acquisition, Logistics, and Technology. Monterey, CA: 15th Annual Acquisition Research Symposium.
- Michaels, D. (2010, January 14). Long-dead inventor Nikola Tesla is electrifying hip techies. *The Wall Street Journal*. Retrieved from <https://www.wsj.com/articles/SB10001424052748704362004575000841720318942>
- National Aeronautics and Space Administration [NASA]. (2008, January 1). Solar irradiance. Retrieved from https://www.nasa.gov/mission_pages/sdo/science/solar-irradiance.html
- NASA. (2018). Shape effects on drag. Retrieved from <https://www.grc.nasa.gov/www/k-12/airplane/shaped.html>
- National Automobile Dealers Association [NADA] (n.d.). Chevrolet Volt models and Volt history. Retrieved from <https://www.nadaguides.com/Cars/Chevrolet/Volt>
- National Renewable Energy Laboratory (NREL). (2017, April 04). Direct normal solar resource of California. Retrieved from <https://www.nrel.gov/gis/solar.html>
- Navitas Systems. (2018). Lithium “6T” Starting/Deep cycle battery specification sheet. Retrieved from <https://www.navitassys.com/products-systems/heavy-duty-off-road-batteries/>
- Navy Education and Training (NAVEDTRA). (n.d.) 14081A—*Equipment operator basic, chapter 7, medium tactical vehicle replacements*. Retrieved from <http://www.navybmr.com/active-duty/eo/eo2/>
- New York State Energy Research and Development Authority. (2011). *Research project summary: NYC refuse fleet hydraulic hybrid demonstration phase 2 (ST9105-1)*. Utica, NY: New York State of Opportunity. Retrieved from <https://www.nyserda.ny.gov/Researchers-and-Policymakers/Research-Project/Research-Projects/Research-Project-Search-Results/Project-Information?p=4837&R=1&PDF=true>

- North American Council for Freight Efficiency [NACFE]. (2014). *Confidence report: idle-reduction solutions*. Retrieved from https://www.rmi.org/wp-content/uploads/2017/04/Idle-Reduction_Confidence_Report.pdf
- North American Council for Freight Efficiency [NACFE]. (2017). *Confidence report on variable engine-driven accessories*.
- North American Council for Freight Efficiency [NACFE]. (2018). *Confidence report: solar for trucks and trailers*. Retrieved from <https://nacfe.org/wp-content/uploads/2018/06/NACFE-Solar-Confidence-Report-June-2018-1.pdf>
- Office of the Secretary of Defense (OSD) Manufacturing Technology Program, (2015, August 4). Manufacturing Readiness Level (MRL) Deskbook Version 2. Retrieved from http://www.dodmrl.com/MRL_Deskbook_V2.4%20August_2015.pdf
- Oshkosh Defense, (n.d.) Product information page. Retrieved June 15, 2018 from <https://oshkoshdefense.com/products/>
- Oshkosh Logistic Vehicle System Replacement (LVSR). (n.d.). In *Wikipedia*. Retrieved 14 June, 2018, from [https://en.wikipedia.org/wiki/Oshkosh_Logistic_Vehicle_System_Replacement_\(LVSR\)](https://en.wikipedia.org/wiki/Oshkosh_Logistic_Vehicle_System_Replacement_(LVSR))
- Padgett, M. (2008, September 10). Toyota Prius: A brief history in time. Retrieved from https://www.greencarreports.com/news/1014178_toyota-prius-a-brief-history-in-time
- Pavlov, D. (2011). *Lead-acid batteries: Science and technology*. Amsterdam, Netherlands: Elsevier Science.
- The Physics Classroom. (2018). Kinetic energy. Retrieved from <https://www.physicsclassroom.com/class/energy/Lesson-1/Kinetic-Energy>
- Program Executive Officer [PEO]. (2012). *Program executive officer land systems advanced technology investment plan—Medium tactical vehicle replacement (MTVR)*. Retrieved from http://www.defenseinnovationmarketplace.mil/resources/MTVR_2012_ATIP.pdf
- Quora. (2018). How do you convert mph to meters per second? Retrieved from <https://www.quora.com/How-do-you-convert-mph-to-meters-per-second>

- Smith, J. (2017, November 17). Tesla's electric semi truck gets orders from Wal-Mart and J.B. Hunt. *The Wall Street Journal*. Retrieved from <https://www.wsj.com/articles/teslas-electric-semi-truck-gets-orders-from-wal-mart-and-j-b-hunt-1510950438>
- Strauss, S. (2011, March 8). Bosch Rexroth installs parallel hydrostatic regenerative braking system in Fairfax County's first hydraulic hybrid trash and recycling vehicle. *Rexroth—a Bosch Company*. Retrieved from <https://www.boschrexroth.com/en/us/company/press/press-details-25088>
- Study.com. (2018). Newton's laws and weight, mass & gravity. Retrieved from <https://study.com/academy/lesson/newtons-laws-and-weight-mass-gravity.html>
- Toyota GB (2015, February 10). History of the Toyota Prius. Retrieved from <https://blog.toyota.co.uk/history-toyota-prius>
- White, F. (2010). *Fluid mechanics* (7th ed.). New York, New York: The McGraw-Hill Companies, Inc.
- Wong, J. Y. (1993). *Theory of ground vehicles* (2nd ed.). Hoboken, NJ, Wiley.
- Woodford, C. (2017, October 12). Regenerative brakes. Retrieved from <http://www.explainthatstuff.com/how-regenerative-brakes-work.html>

THIS PAGE INTENTIONALLY LEFT BLANK

INITIAL DISTRIBUTION LIST

1. Defense Technical Information Center
Ft. Belvoir, Virginia
2. Dudley Knox Library
Naval Postgraduate School
Monterey, California