

USAARL Report No. 2018-21

White Paper and Tutorial on the Use of the Ann Arbor Distortion Tester for Evaluation of Nonprescription Protective Eye Wear and Windows such as Visors, Face Shields, Protective Masks, and Safety Glasses

By William McLean^{1,2}

¹U.S. Army Aeromedical Research Laboratory

²Voluntary Emeritus Program



United States Army Aeromedical Research Laboratory

Warfighter Performance Group

September 2018

Approved for public release; Distribution unlimited.

Notice

Qualified Requesters

Qualified requesters may obtain copies from the Defense Technical Information Center (DTIC), Fort Belvoir, Virginia 22060. Orders will be expedited if placed through the librarian or other person designated to request documents from DTIC.

Change of Address

Organizations receiving reports from the U.S. Army Aeromedical Research Laboratory on automatic mailing lists should confirm correct address when corresponding about laboratory reports.

Disposition

Destroy this document when it is no longer needed. Do not return it to the originator.

Disclaimer

The views, opinions, and/or findings contained in this report are those of the author(s) and should not be construed as an official Department of the Army position, policy, or decision, unless so designated by other official documentation. Citation of trade names in this report does not constitute an official Department of the Army endorsement or approval of the use of such commercial items.

REPORT DOCUMENTATION PAGE

*Form Approved
OMB No. 0704-0188*

The public reporting burden for this collection of information is estimated to average 1 hour per response, including the time for reviewing instructions, searching existing data sources, gathering and maintaining the data needed, and completing and reviewing the collection of information. Send comments regarding this burden estimate or any other aspect of this collection of information, including suggestions for reducing the burden, to Department of Defense, Washington Headquarters Services, Directorate for Information Operations and Reports (0704-0188), 1215 Jefferson Davis Highway, Suite 1204, Arlington, VA 22202-4302. Respondents should be aware that notwithstanding any other provision of law, no person shall be subject to any penalty for failing to comply with a collection of information if it does not display a currently valid OMB control number.

PLEASE DO NOT RETURN YOUR FORM TO THE ABOVE ADDRESS.

1. REPORT DATE (DD-MM-YYYY) 17-09-2018	2. REPORT TYPE Final	3. DATES COVERED (From - To)
--	--------------------------------	-------------------------------------

4. TITLE AND SUBTITLE White Paper and Tutorial on the Use of the Ann Arbor Distortion Tester for Evaluation of Nonprescription Protective Eye Wear and Windows such as Visors, Face Shields, Protective Masks, and Safety Glasses	5a. CONTRACT NUMBER N/A
	5b. GRANT NUMBER N/A
	5c. PROGRAM ELEMENT NUMBER N/A

6. AUTHOR(S) McLean, William	5d. PROJECT NUMBER N/A
	5e. TASK NUMBER N/A
	5f. WORK UNIT NUMBER N/A

7. PERFORMING ORGANIZATION NAME(S) AND ADDRESS(ES) U.S. Army Aeromedical Research Laboratory P.O. Box 620577 Fort Rucker, AL 36362	8. PERFORMING ORGANIZATION REPORT NUMBER USAARL 2018-21
--	---

9. SPONSORING/MONITORING AGENCY NAME(S) AND ADDRESS(ES)	10. SPONSOR/MONITOR'S ACRONYM(S)
	11. SPONSOR/MONITOR'S REPORT NUMBER(S) N/A

12. DISTRIBUTION/AVAILABILITY STATEMENT
Approved for public release; distribution unlimited.

13. SUPPLEMENTARY NOTES

14. ABSTRACT
This paper was prepared to aid in dissemination of information on distortion testing to obtain uniformity among government testers of nonprescription windows such as protective eye wear, visors, and masks as specified in MIL-V--43511C & D, Visors, Flyer's Helmet, Polycarbonate or equivalents.

15. SUBJECT TERMS

16. SECURITY CLASSIFICATION OF:			17. LIMITATION OF ABSTRACT SAR	18. NUMBER OF PAGES 26	19a. NAME OF RESPONSIBLE PERSON Loraine St. Onge, PhD
a. REPORT UNCLAS	b. ABSTRACT UNCLAS	c. THIS PAGE UNCLAS			19b. TELEPHONE NUMBER (Include area code) 334-255-6906

This page is intentionally blank.

Table of Contents

	Page
Introduction.....	1
Initial Set-Up.....	2
Calibration and Quantification of Lens Power	3
Pass/Fail Criteria.....	4
Summary.....	13
Appendix A.....	14
Appendix B.....	15

List of Figures

1. Distortion Tester Schematic.....	1
2. Initial lens placement	4
3. Lens too far from grating	5
4. Adjust lens vertical height	5
5. Correct distortion pattern, no test item	6
6. Possible effects of rotating lens (B) orientation (front/back position).....	6
7. Minus or negative lens power effects	7
8. Positive or plus lens power effects.....	7
9. Astigmatic or cylinder power effect when power meridian aligned with grating	8
10. Astigmatic or cylinder power effect when rotated relative to grating.	8
11. Astigmatic or cylinder plus lens power effect when axis aligned with grating	9
12. Distortion pattern example 1, left eye, nasal view.....	9
13. Distortion pattern example 2, left eye, nasal view.....	10
14. Distortion pattern example 3, with 45 degree rotation nasal view.	11
15. Distortion pattern example 4, “as worn” marginally acceptable	12
16. Distortion pattern example 5, lens rotated, unacceptable	12
17. Lens surface defects.....	13

This page is intentionally blank.

Introduction

The Research Development and Engineering Command requested that the U.S. Army Aeromedical Research Laboratory summarize the use and evaluation criteria of the Ann Arbor Distortion Tester. This distortion test is specified and used to evaluate non-prescription protective eyewear such as visors, sun/wind/dust goggles, protective mask lenses, and other protective eye shields. A referenced specification is Visors, Flyer's Helmet, Polycarbonate, 16 July 1990. A later version, MIL-DTL-43511D replaced the C version was approved 12 Oct 2006, but is not approved for the U.S. Army, which uses MIL-V-43511C.

It is hoped that this paper will assist in obtaining agreement on test procedures and results by all three services and protective eyewear manufacturers.

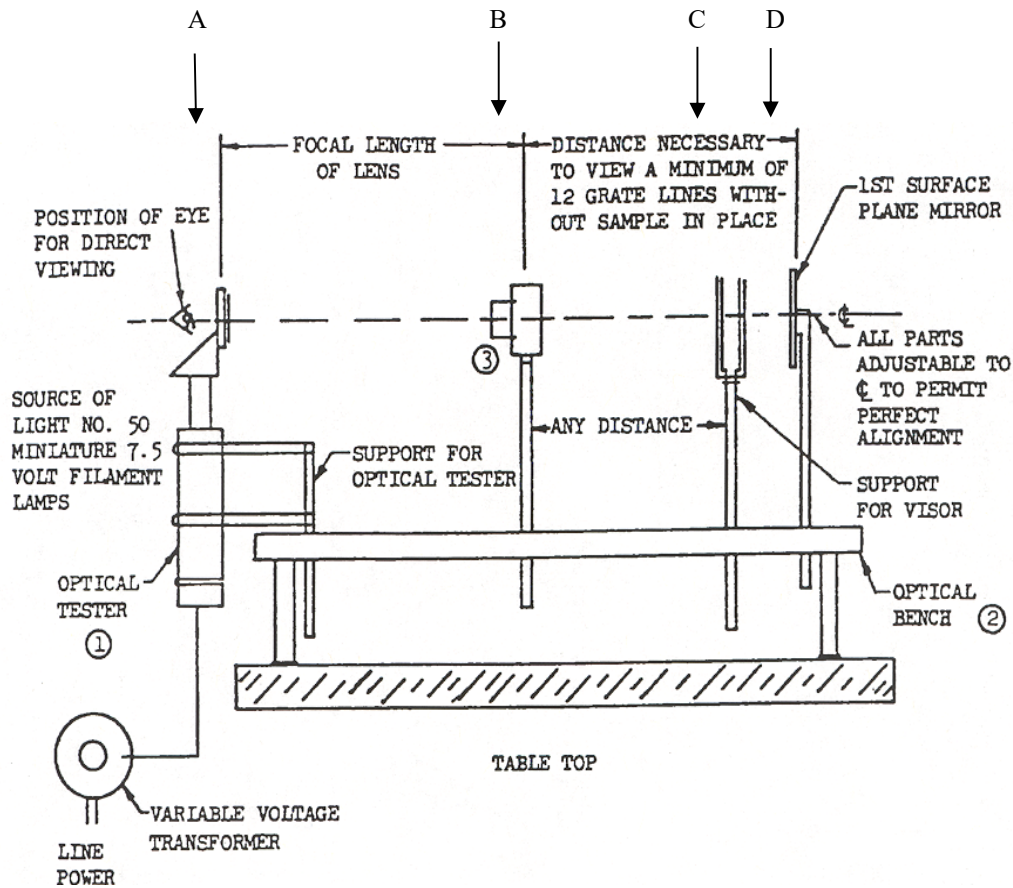

Figure 1. Distortion tester. Taken from MIL-V-43511C, Detail Specification. 1) Model "B" or equivalent optical tester with a 50- to 60-line grating, with optical bench adapter or equivalent. 2) The complete test assembly, or components, depicted in this figure may be obtained as the model E distortion tester from Data Optics, Inc., 115 Holmes Road, Ypsilanti, MI 48198-3020, phone 800-321-9026 or 313-483-8288.

Initial Set-Up

In Figure 1, letters A, B, C, and D show the positions of the 50-60 line grating, achromatic lens, sample holder, and front surface mirror, respectively. Normally the sample holder (C) is not positioned until distortion pictures are taken. Sample lenses are usually hand held so they can be properly positioned and rolled to check all meridians for distortion. The lens at position B was originally specified as a 240-mm Schneider tele-Arton 1:5.5 (43 mm effective diameter) normal color coated, or an equivalent. However the Schneider lens has not been available for about 50 years. Therefore, various achromatic lenses, such as objectives from telescopes and binoculars will work. We use a 250-mm focal length, 50-mm diameter lens (F3.6). Also, the 60 line/inch grating may not be available, so most systems are using the 50 line/inch grating. Obtaining the same results with different lenses will be discussed in the next section.

Contrary to Figure 1, the lens (B) should be positioned CLOSER to the grating (A) than the focal length of the lens by about 10 percent initially. If you don't know the focal length of the lens, the correction position can be determined by observing the number of grating lines. The distance from the lens (B) to the front surface mirror (D) is not critical and should be about the same distance as the distance between the lens (B) and grating (A), so the sample can be moved easily without making contact with any of the distortion tester components.

With the components aligned on an optical bench at approximately the same height, turn on the illumination source in the grating holder. Most likely when you first look through the device with your eye in front of the grating as shown in Figure 1, you'll probably see nothing. The alignment of the front surface mirror (D) is critical to having the light return through the system. Therefore, you must be able to yaw and tilt the mirror slightly until you see the light return from the grating.

With the mirror properly aligned, the grating lines may appear elliptical with a reduced vertical height compared to the pictures you've seen. You can make small adjustments of the height of the lens (B) and change the apparent vertical height of the grating. You may also have to slightly change the pitch of the front surface mirror (D) at the same time to reflect the light back towards the eye.

Next step is to adjust the number of visible grating lines. Contrary to the Figure 1, the number of visible grating lines is controlled by the distance from the grating (A) to the lens (B). I prefer to fix the position of the grating (A) and move the lens (B). You should start with the lens (B) about 4 to 5 inches from the grating (A). In this position, you should see about 20 to 40 lines (Figure 2). As you move the lens (B) away from the grating (A), the number of visible lines will reduce. Continue moving the lens away from the grating until you count between 12 and 14 lines. This is the correct position to obtain similar results for the various focal length and diameter lenses. If you continue to increase the distance between the lens and grating, you will see only one or no lines. This is approximately the focal length of the lens. As you go past this point the number of

visible lines will increase, but the characteristics of the distortion tester are changed, which will be discussed later.

Varying the distance between the lens (B) and the front surface mirror (D) WILL NOT change the number of visible lines. As the distance is increased between the front surface mirror and the lens, the quality of the apparent grating lines may decrease.

The lens (B) actually has a front and a back. If the lens is rotated 180 degrees in the vertical axis (front to back), the visible lines may change from straight to bowed out towards the lateral edges from pin cushion distortion (Figures 2 and 3). Rotate the lens (yaw) 180 degrees to verify that the lens is not positioned backwards, and the lines are straight in the center and lateral edges.

The effect of the placement of the sample between the lens (B) and the front surface mirror (D) will not affect the distortion pattern, but as the sample is moved towards the mirror, the surface defects of the sample become more visible.

Calibration and Quantification of Lens Power

The Ann Arbor Distortion tester is very sensitive to changes in lens power within a sample lens. With 12 to 14 lines showing without a sample, Figure 4 shows the effects with a + 0.125 diopter lens. Note the decrease in the number of visible lines and an increase in the spacing between the lines. Figure 5 shows the line pattern with a -0.125 lens. Note the increase in the number of lines. An increase or decrease of one line in the pattern is approximately a 0.04 diopter change. Figure 6A shows line pattern with a -0.25 diopter cylinder lens (astigmatism) with the axis aligned with the grating lines. Note the increase in the number of visible lines. Figure 6B shows the pattern with the same -0.25 diopter cylinder lens rolled 90 degrees with the axis perpendicular to the grating lines. Note that there is no change in the number of visible lines or the spacing between the lines. When the axis of the -0.25 diopter cylinder lens is rotated 45 degrees to the grating lines, note the uniform tilting of the lines through the lens. Prism power doesn't change the lines, but may deviate the light from returning to the eye.

Therefore to properly evaluate distortion in a lens sample, the lens must be rotated (rolled) at least 90 degrees. Rotation of the lens sample is described in the original *Instruction Manual for the Optical Tester*, Ann Arbor Optical Company (1962). The maximum visible distortion or bending of the lines for samples failing the pass/fail criteria should be photographed with a small digital or CCD camera using low resolution (1 Meg or less) to document the distortion. Usually the best focus for the camera is infinity or manual, and not using the automatic focusing of the camera. The camera is placed behind the grating where the eye would normally be. Slight adjustments in height, lateral position and yaw of the camera will help center the image and minimize any skewed effects. The size of the circular distortion pattern image should be about 1/2 the diameter of the camera image. After the camera image is down loaded, the image can be cropped and sized for the report.

Pass/Fail Criteria

Since changing power changes the number of visible lines, if the line spacing increased by a factor of 2 (plus power), we would only see 6 to 7 lines; or if the spacing decreased by a factor of 1.5 (minus power), we would see 18 to 21 lines. Therefore, if a line bends to where it would have touched the adjacent line if it had not been affected, is an equivalent change in the number of lines of approximately 6 or 7 and a lens power difference of (6 or 7 x 0.04 diopter) or 0.24 to 0.27 diopter lens change in that local area. Note in the examples of the pass and fail criteria, that the acceptable examples do not have lines deviating up to one line spacing. Therefore, the fail criteria is any line deviating more than one line spacing (6-8 in Pass/Fail Criteria) or shear patterns (9 in Pass/Fail Criteria) with more than 1/2 line displacement. When distortion is seen on the sample lens that doesn't meet the pass criteria, the measured lens power in this area will most likely exceed the +/- 0.125 diopter criteria for refractive power if measured with an auto lenometer with a beam diameter of less than 5-mm. However, we have had lenses that passed the distortion criteria, but failed the lens power from minus power astigmatism that was fairly uniform throughout the critical area.

Sample Lenses and Examples

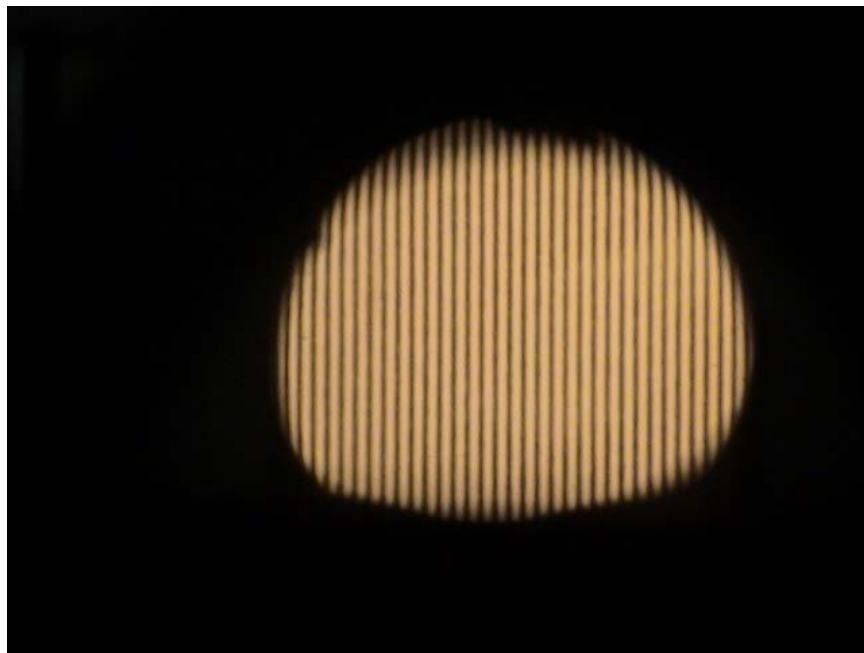

Figure 2. Initial lens placement

The lens (B) is closer to the grating (A) than the focal and shows many more lines than the specified 12-14. Move the lens away from the grating and the number of lines should reduce. If the number of lines increases as the distance between the lens (B) and grating (A) is increased, you've gone past the focal length.



Figure 3. Lens too far from grating.

When the lens (B) is placed very near the focal length from the grating (A), only one or no lines will be visible.

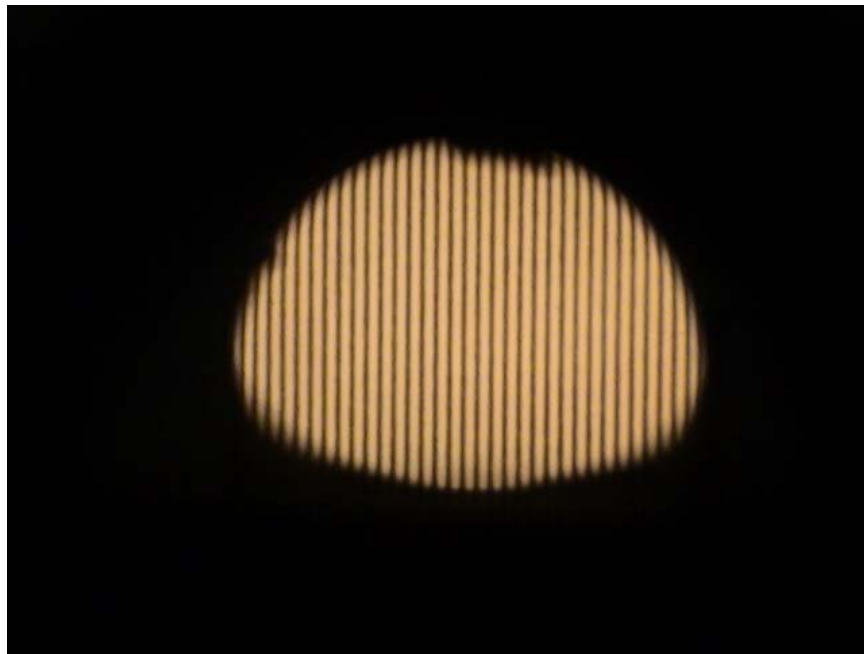

Figure 4. Adjust lens vertical height

After the mirror (D) has been adjusted to return the light back towards the observer, you may notice that the lines are clipped vertically. Move the lens vertically slightly and the lines will appear more circular.

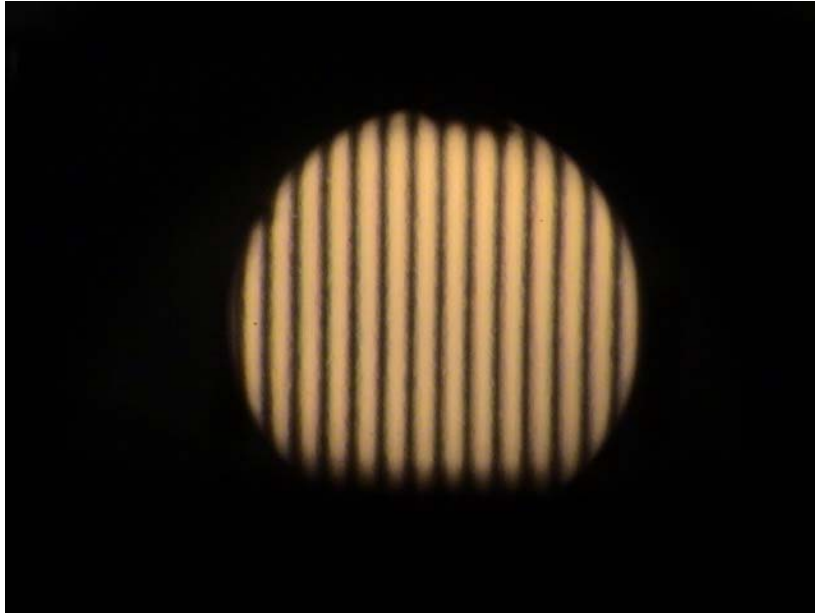

Figure 5. Correct distortion pattern, no test item.

With the correct distance of the lens from the grating and the vertical height of the lens adjusted (may have to slightly tilt the mirror when changing the vertical height of the lens), the 12-14 lines in a circular pattern should be seen.

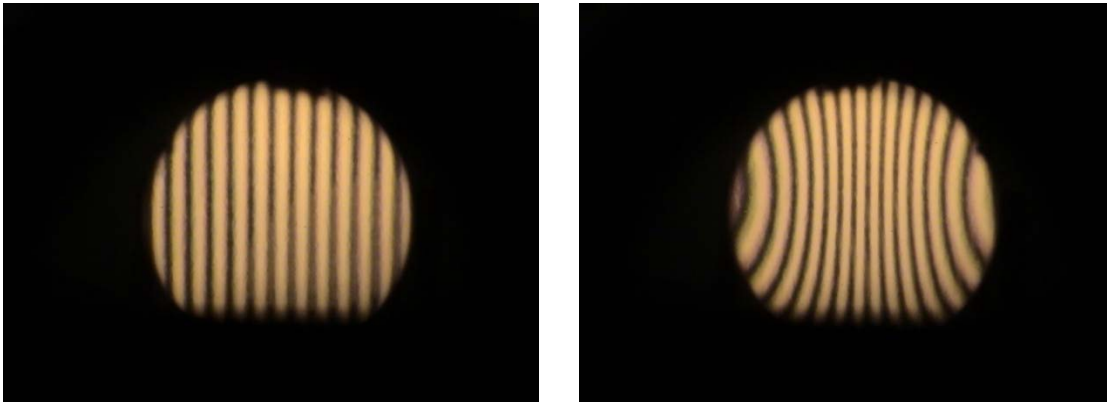

Figure 6. Possible effects of rotating lens (B) orientation (front/back position)

These two figures show what happens if the lens (B) is placed backwards. Note the pin cushion distortion of the outside lines. If you don't see straight lines, rotate the lens in the distortion tester 180 degrees around the vertical axis. If the lines are still not straight, recommend finding another achromatic lens. This is also the reason we insist that any reported distortion pictures show the grating lines first without any sample lenses in place to verify the number of visible lines and the quality of the image.

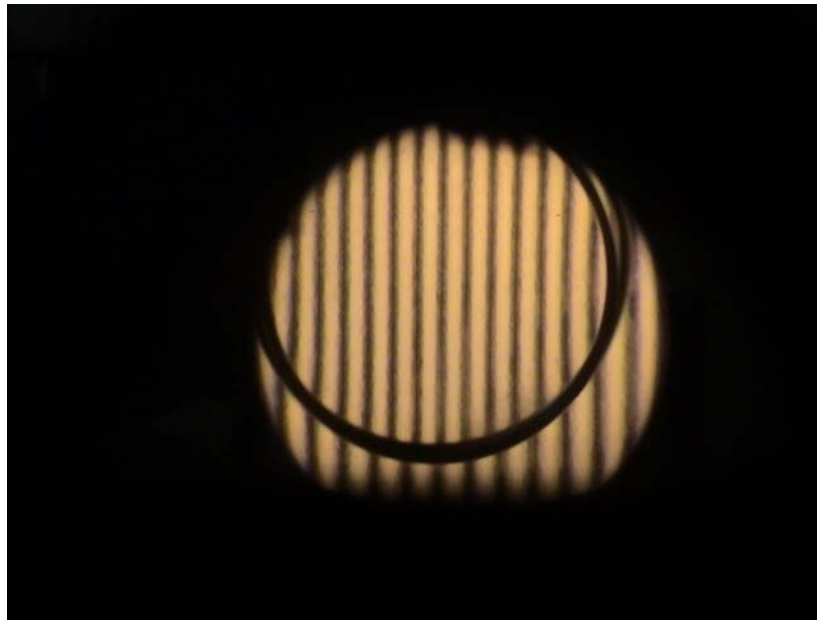

Figure 7. Minus or negative lens power effects

An ophthalmic trial lens with -0.125 diopter spherical lens is inserted between the lens in the distortion tester and the mirror. Note that the number of visible lines increase and the spacing between the lines decrease.

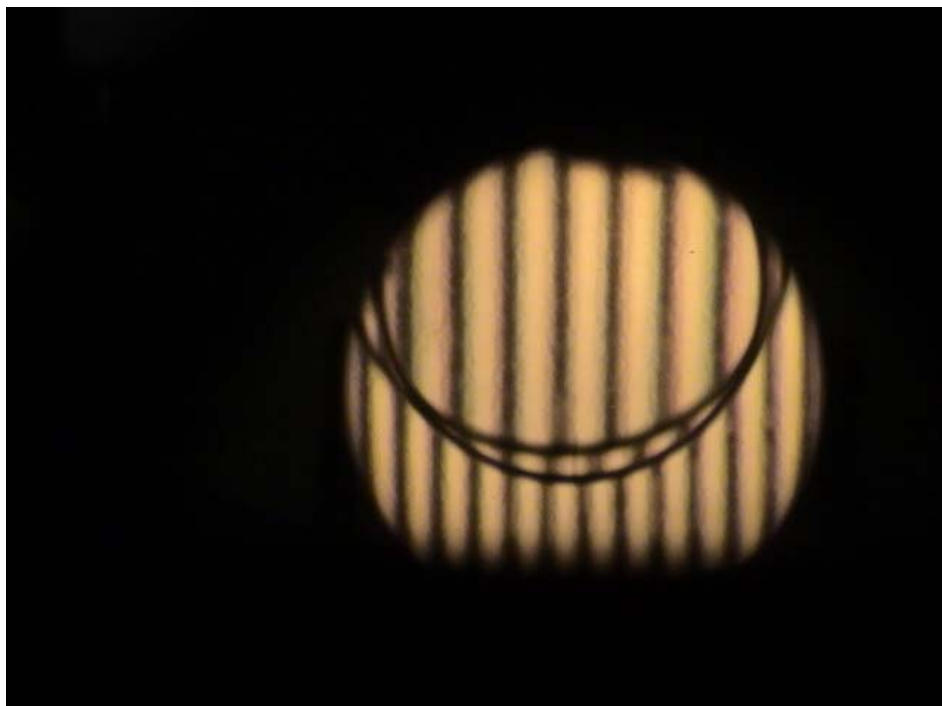

Figure 8. Positive or plus lens power effects

With a $+0.125$ diopter spherical ophthalmic trial lens, the number of visible lines decreases and the spacing between the lines increases. You'll also note the rim of the trial

frame is slightly doubled from the double pass of the rays. You will see the outline of the critical area of a sample lens slightly double also.

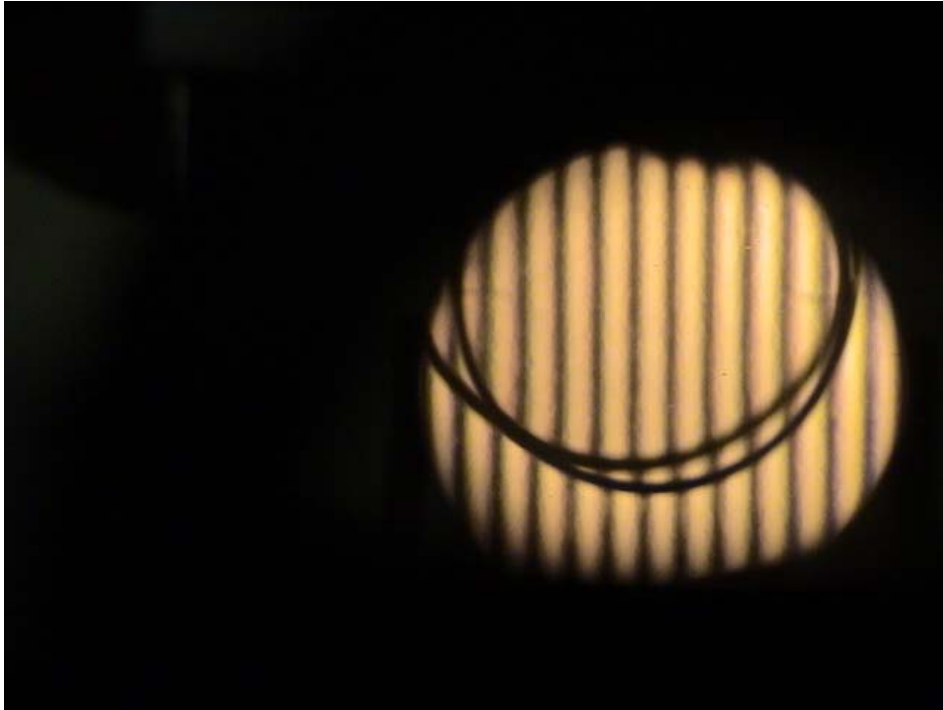

Figure 9. Astigmatic or cylinder power effect when power meridian aligned with grating.

This figure shows a +0.25 diopter astigmatic (cylinder) lens with the power meridian in line with the grating lines (axis 90 degrees to grating). Note that there is no change in the spacing or number of visible lines.

This space is intentionally blank.

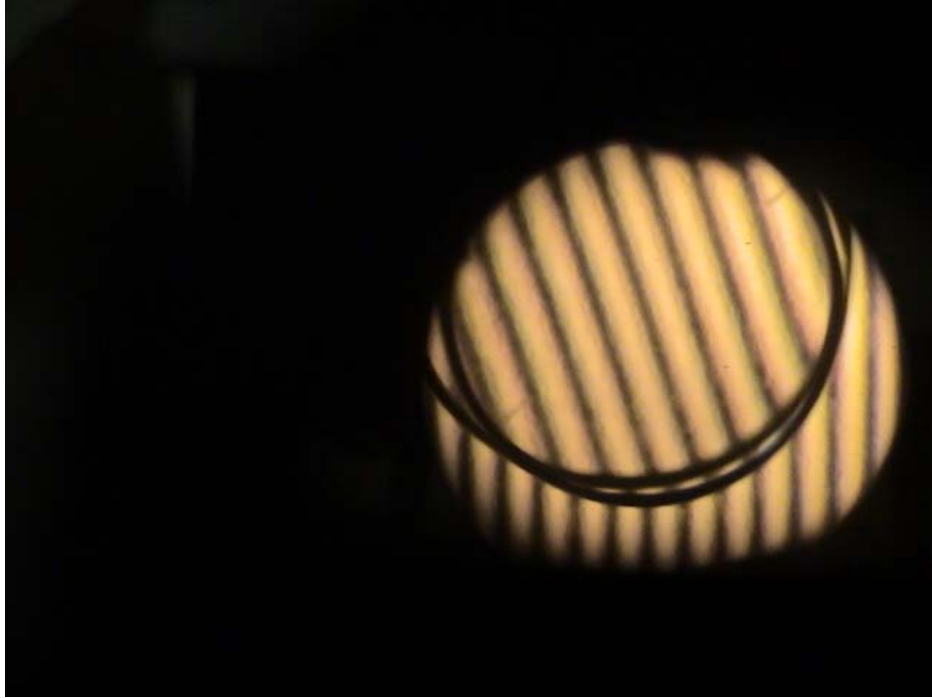

Figure 10. Astigmatic or cylinder power effect when rotated relative to grating.

With the +0.25 diopter cylinder lens rotated 45 degrees to the grating lines in the distortion tester. Note the slanting of the lines in unison and the increase in the line spacing from the resulting increase in plus power in the 45 degree meridian.

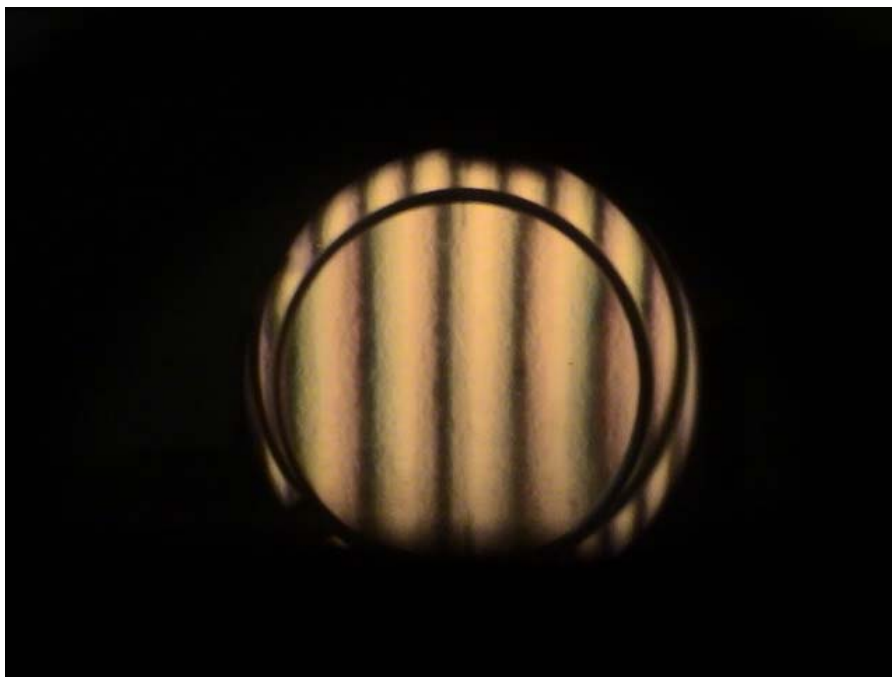

Figure 11. Astigmatic or cylinder plus lens power effect when axis aligned with grating

With the +0.25 diopter cylinder lens rotated 90 degrees, and the power meridian 90 degrees to the line orientation, the spacing appears the same as a +0.25 diopter spherical lens regardless of orientation.

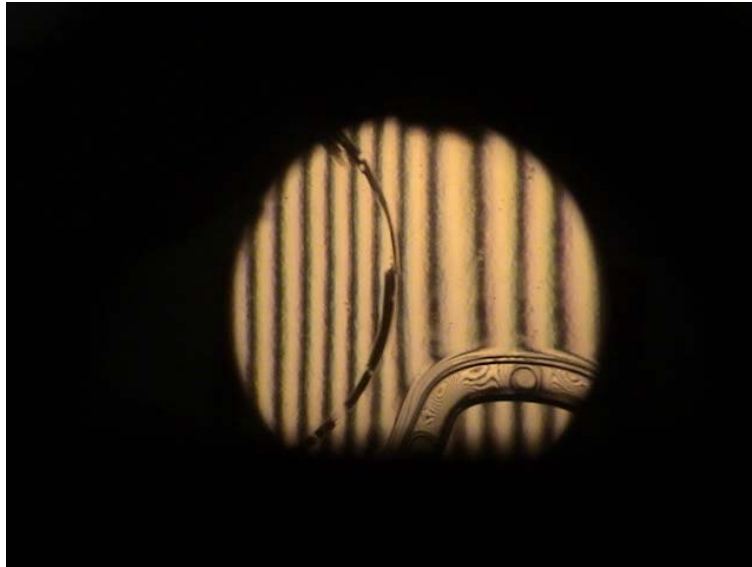

Figure 12. Distortion pattern example 1, left eye, nasal view.

This is an actual lens from a recently tested commercial Sun/Wind/Dust goggle. The partial circular line is the critical zone according to the current specifications in the Commercial Eye Protection (CEP) program. The separation between the right and left critical zones is 64-mm according to this specification. The nose bridge of the lens is visible in the lower right hand corner. Note the increase in the line spacing in the area between the right and left critical zone when the lens is held in an “as worn,” horizontal position.

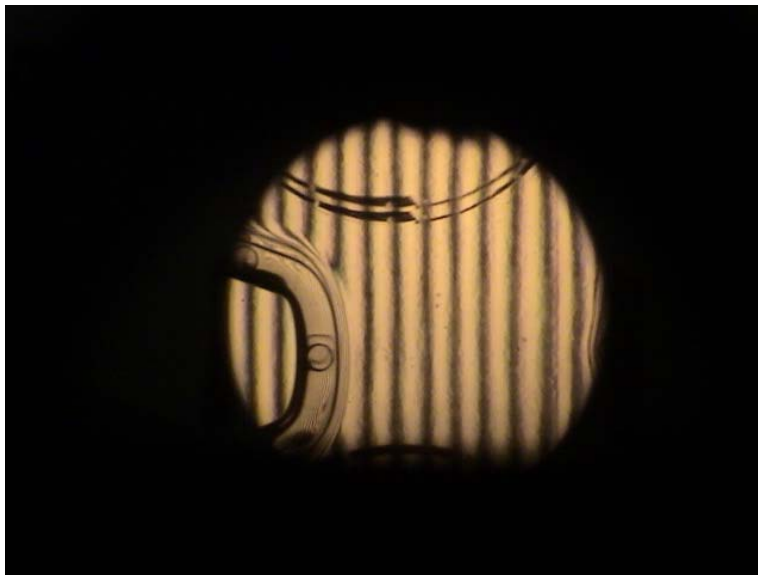

Figure 13. Distortion pattern example 2, left eye, nasal view

When this same SWD lens is held in as “as worn,” but rolled 90 degrees, note that the distortion lines were not noticeably changed. The reason is the small astigmatism or cylinder power meridian is 90 degrees to the grating. The lens power in the area between the right and left critical zones measured: $+0.17 -0.18 \times 180$. Therefore the increase in spacing when held horizontal was showing the effects of plus lens power, which the cylinder component (-0.18) cancelled out the power when the lens is twisted 90 degrees.



Figure 14. Distortion pattern example 3, with 45 degree rotation nasal view.

As expected, when the lens is rolled 45 degrees, the twisting lines are apparent, which are a results of the cylinder or astigmatic power. If this distortion were in the critical area, it would be unacceptable.



Figure 15. Distortion pattern example 4, “as worn” marginally acceptable.

This lens is a polycarbonate protective tinted outsert to a prototype Joint Service General Purpose Mask variant. Note the changes in the line spacing which is indicative of changes in lens power. The twisting would be astigmatism.



Figure 16. Distortion pattern example 5, lens rotated, unacceptable.

When this lens is rotated, you’ll see the twisting of the lines beyond one line width from the cylinder power, which makes this lens unacceptable. If an autolensometer with 0.01 diopter increments is used, you’ll see lens powers where the distortion is seen that exceed the ± 0.125 lens power in any meridian specification for this particular lens.

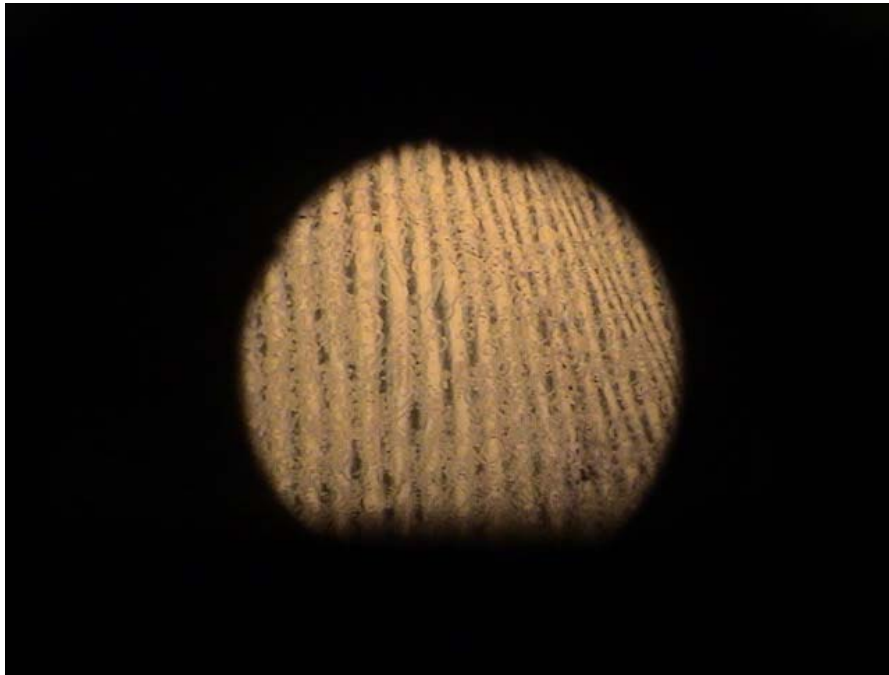

Figure 17. Lens surface defects.

This is a chemical mask primary lens after exposed to a particular chemical that affected the surface of the lens. The mask lens is placed close to the mirror (D) to improve the clarity of the photograph of surface defects. These defects also caused the lens to fail the haze criteria.

Summary

The Ann Arbor Distortion Tester is an optical tool to quickly evaluate the lens quality of plano, nonprescription lenses, goggles, visors, and face shields. The distortion pattern image only shows one meridian effects, so the sample lens must be rotated up to 90 degrees to view all meridians. The changes in the shape and number of visible lines in the distortion pattern are a function of small refractive lens powers, which can be validated with auto lensometers with 0.01 diopter increments, and by photography.

Appendix A. Acceptable and Unacceptable Criteria

The Acceptable/Unaccept Criteria taken from MIL-V-43511C

Note that this pass/fail criteria and sample illustration have not changed since the Helmet Visor standard was written. However, agreement among the Air Force, Navy and Army around 1970 was the number of lines without a sample should be 12-14, and not 8-10 as shown, but the criteria of line deviations for pass and fail would remain the same as shown in the figures. You'll note that any deviation of a line more than 1 line spacing and/or shearing of the grating lines were rated as unacceptable.

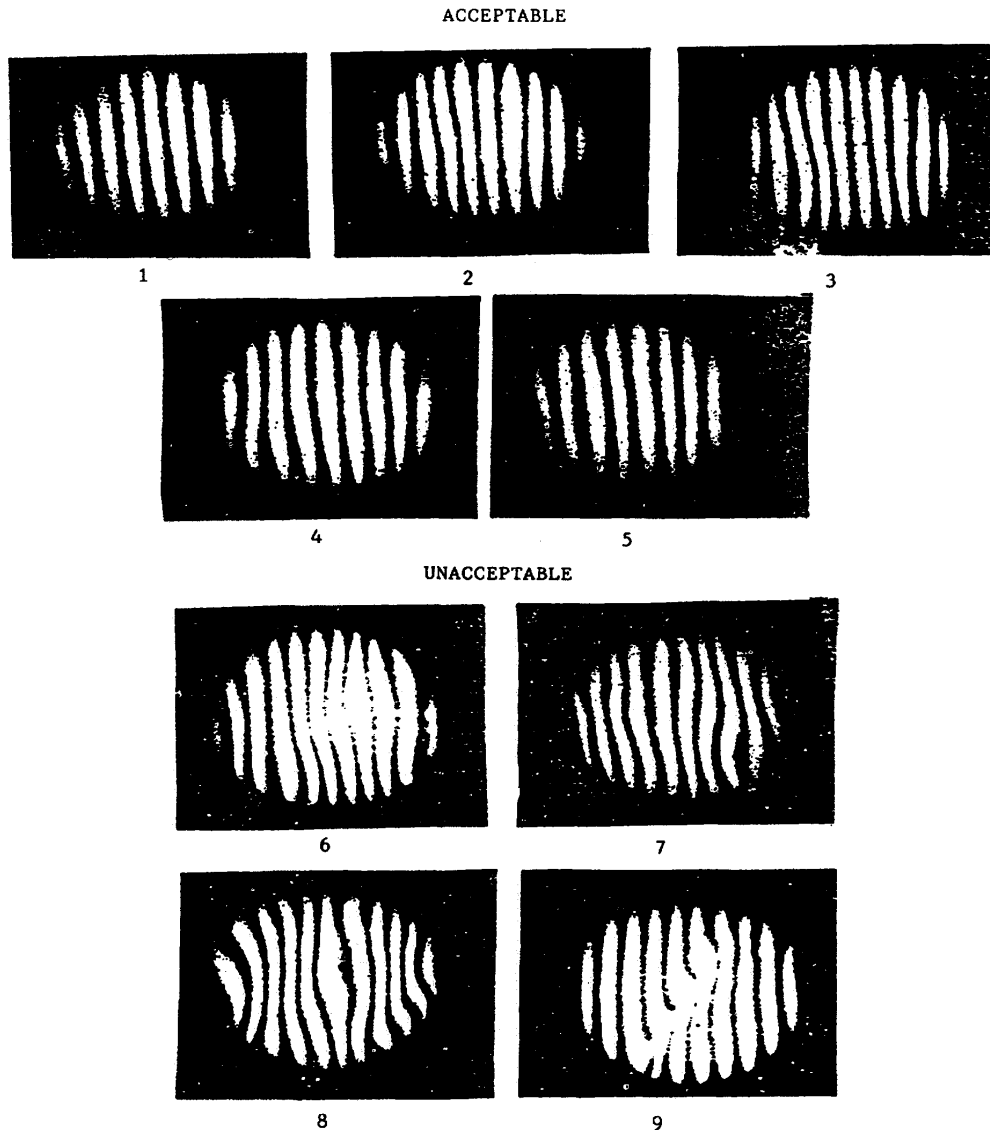

FIGURE 1. VISORS DISTORTION STANDARDS

Appendix B. Brochure on Ann Arbor Distortion Tester

The U.S. Government does not recommend or endorse this product or manufacturer, but are not aware of any other source for the Ann Arbor distortion tester that qualifies for distortion testing as specified in MIL-V-43511C or equivalent specifications.

DATA OPTICS, INC.

115 HOLMES ROAD • YPSILANTI MICHIGAN 48198-3020

Model C Optical Tester

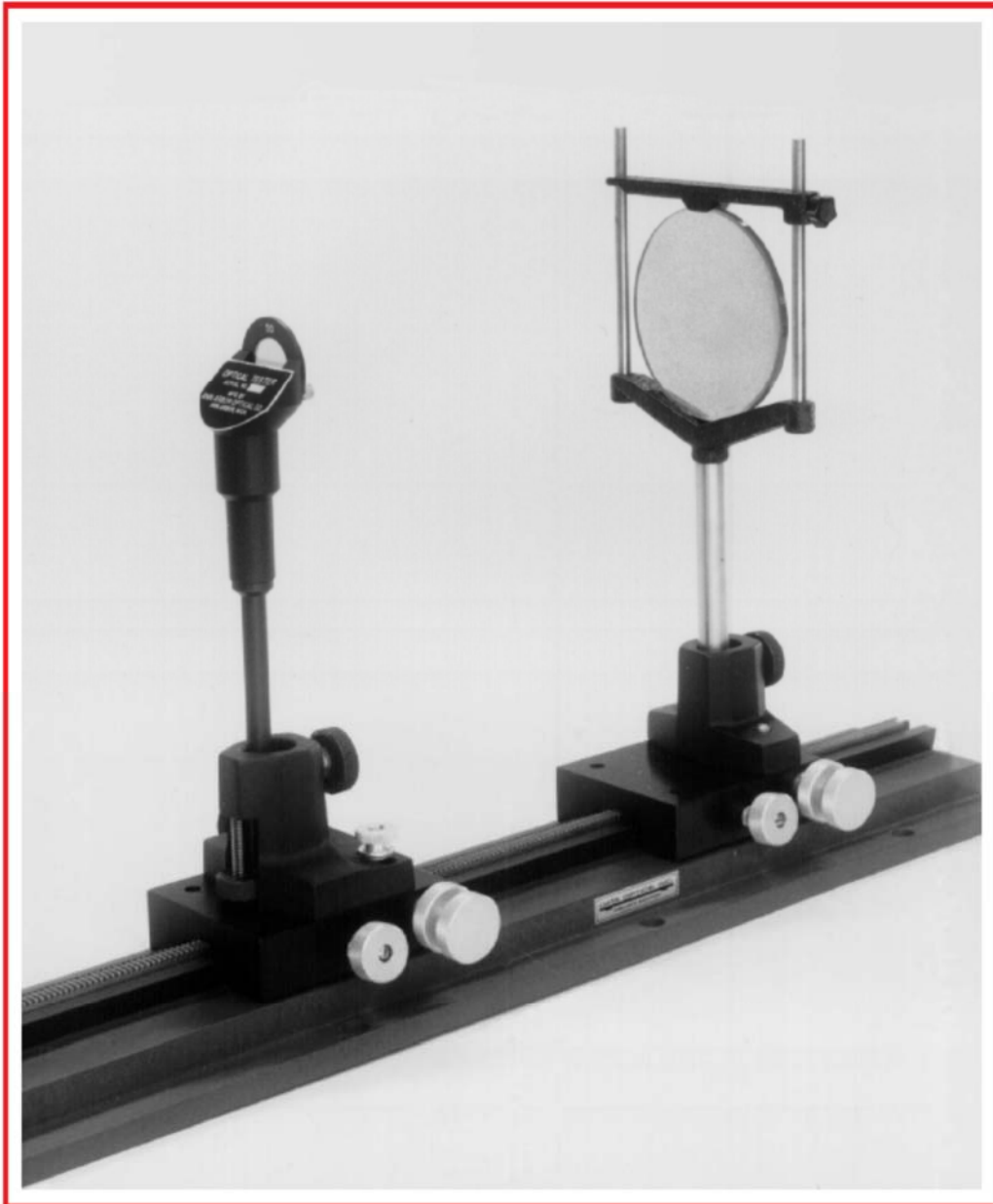

For Testing the Quality of Lenses, Mirrors and Optical Windows

PRINCIPLE

The Model C Optical Tester is based on the method introduced by V. Ronchi and M. Lenouvel. When a lens, mirror or optical window is illuminated through a grating of equally spaced transparent and opaque bands, as in Figure 1, with the grating near the focal plane F, then the eye, placed at P in the returning beam of light sees a number of dark lines which appear localized on the lens.

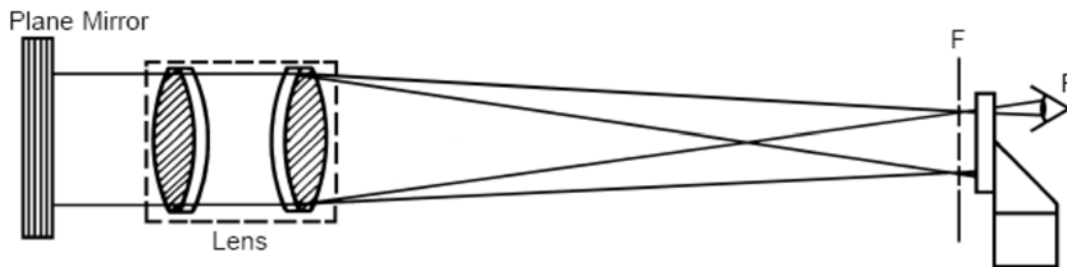

Figure 1

In Figure 1, if the grating is behind the focal plane, then its image is an equal distance in front. Upon looking at the lens through the grating, all the rays passing through the grating image cannot reach the eye, as they are stopped by the opaque parts of the grating. As a result, a pattern of light and dark lines is seen.

If the lens is well corrected, the shadow lines or fringes are straight, parallel, and equidistant. The distance separating them increases as the grating is moved nearer to the focal plane, at which point they disappear completely. In the case of a poor lens or mirror the fringes have a complex form, varying according to the position of the grating. The pattern covers the entire lens (or mirror) when testing optics having focal lengths greater than 3 to 4 inches. For shorter focal lengths, the examination is limited to proportionally smaller portions of the lens.

METHOD OF USE

The Optical Tester can be hand-held for a casual inspection of mirrors and lenses. However, for an accurate measurement of focal length or a critical analysis, it should be clamped in position, preferably with some mechanical adjustment for movement toward and away from the optical component being inspected. For this purpose, an adjustable laboratory stand of any kind can be used. Also good for this purpose is an inexpensive type of optical bench such as those used for instructional use. The particular optical arrangement depends on the type of lens or mirror being inspected, and the laboratory facilities available. A dark room is not necessary. A photographic record of the pattern can be made by mounting the Optical Tester before a suitable camera.

APPLICATIONS

LENSES: Both single lenses and lens systems can be tested for focal length. The location of focal planes can be determined to exacting accuracy. Figure 2 shows the patterns obtained at the distances indicated inside the focal plane of an 8" objective. A defect at the center of this lens is evident from these patterns. Aberrations (spherical, coma, chromatic) can be detected and measured.

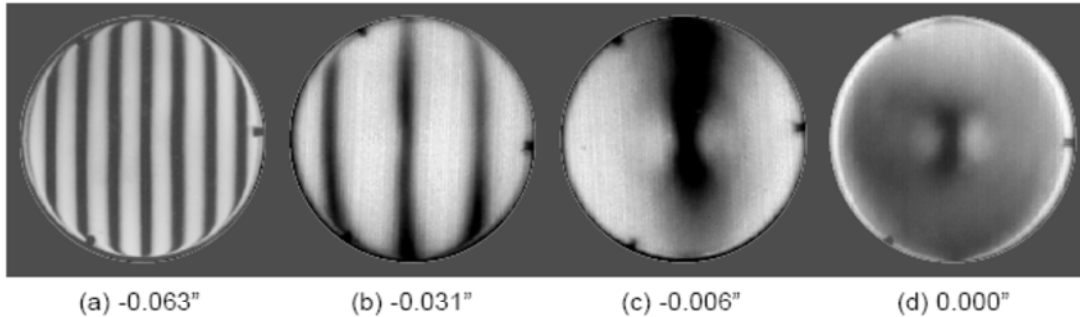
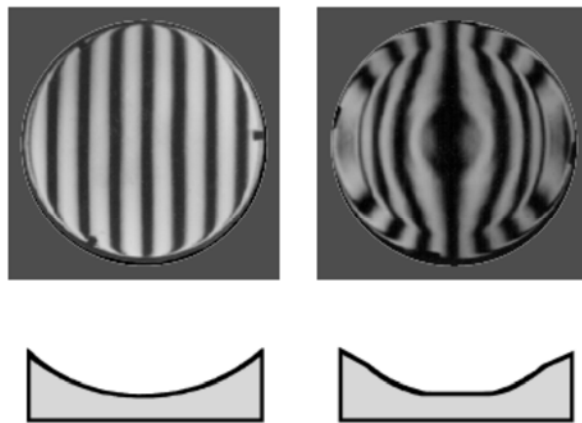

Figure 2

MIRRORS: Spherical and parabolic mirrors can be tested both for focal length and accuracy of optical figure. In addition, the Optical Tester can be used to determine the position of the optic axis of off-axis parabolic mirrors. Figure 3 shows patterns observed when examining two spherical mirrors with the Optical Tester. A visual analysis of the fringes in the patterns shows the contours of the mirror surfaces to be as illustrated. The variations in the contour at the right have been exaggerated for illustrative purposes; the variation in the radius of curvature is really less than 0.4% over the entire surface of this mirror.



OTHER USES: The Optical Tester can be used for the detection or observation of a local distortion in an optical path, due to a change in surface or index of refraction. An example of this is the examination of plastic and glass windows for distortion. Another example is the observation of local temperature variations in small bodies of water and other fluids. Temperature gradients of less than 0.1°C. have been observed by this method.



MODEL C OPTICAL TESTER

The Model C Optical Tester consists of the head unit, containing the light source and optics to illuminate the Ronchi Ruling, and a 0.5 inch diameter handle for either hand-holding or for mounting on an optical bench carriage or laboratory stand. The unit is powered by a multi-step transformer for operating directly from 110/220 V A.C. 50/60 Hz. Three transmission Ronchi Rulings (50, 100, and 200 lines per inch) are included, along with a demonstration lens and mirror, two spare bulbs, and instruction manual. The components are housed in a sturdy plastic carrying case.

MODEL E DISTORTION TESTER (MIL SPEC System)

The Model E Distortion Tester is for testing those products that may have moderate amounts of distortion, such as pressed or formed parts of glass or plastic. It can be used for performing the distortion tests required in several military specifications, such as MIL SPEC V-45311. The system consists of a Model C Optical Tester Kit, a 60 line per inch Ronchi Ruling, achromatic lens, front surface mirror and test specimen holder, all mounted on a 24" optical rail. Custom specimen holders are also available.

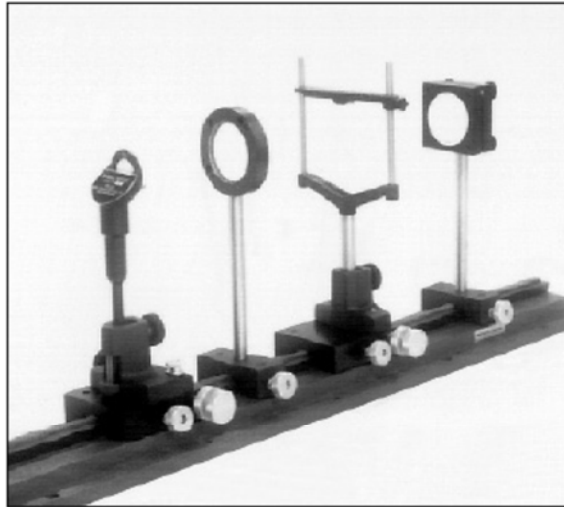

ORDERING INFORMATION

Model C Optical Tester Kit – complete with 3 Ronchi Rulings (50, 100, and 200 lines per inch) demonstration lens and mirror, power supply, two spare bulbs, case and instruction manual.

Model E Distortion Tester Kit (MIL SPEC System) – as shown above, with 60 lines per inch Ronchi Ruling, 220mm FL achromatic lens, 1/4 wave Front Surface Mirror and 24" optical rail.

Ronchi Rulings – 1" diameter, in mounting ring, available in four standard frequencies of 50, 60, 100, and 200 lines per inch.

DATA OPTICS, INC.

115 HOLMES ROAD • YPSILANTI MICHIGAN 48198-3020

1998

(800)321-9026
(734)483-8228
Fax: (734)483-9879
www.dataoptics.com

Printed in the U.S.A.



Department of the Army
U.S. Army Aeromedical Research Laboratory
Fort Rucker, Alabama 36362-0577
www.usaarl.army.mil



U.S. Army Medical Research and Materiel Command