



**ANALYSIS AND DESIGN OF MODULAR OVERHEAD PROTECTION  
SYSTEM UTILIZING READILY AVAILABLE MATERIALS**

THESIS

Zachary J. Spranger, Captain, USAF

AFIT-ENV-MS-19-M-198

**DEPARTMENT OF THE AIR FORCE**

**AIR UNIVERSITY**

***AIR FORCE INSTITUTE OF TECHNOLOGY***

---

---

**Wright-Patterson Air Force Base, Ohio**

**DISTRIBUTION STATEMENT A.**

**APPROVED FOR PUBLIC RELEASE; DISTRIBUTION UNLIMITED.**

The views expressed in this thesis are those of the author and do not reflect the official policy or position of the United States Air Force, Department of Defense, or the United States Government. This material is declared a work of the United States Government and is not subject to copyright protection in the United States.

AFIT-ENV-MS-19-M-198

**ANALYSIS AND DESIGN OF MODULAR OVERHEAD PROTECTION  
SYSTEM UTILIZING READILY AVAILABLE MATERIALS**

THESIS

Presented to the Faculty

Department of Engineering Management

Graduate School of Engineering and Management

Air Force Institute of Technology

Air University

Air Education and Training Command

In Partial Fulfillment of the Requirements for the  
Degree of Master of Science in Engineering Management

Zachary J. Spranger, BS

Captain, USAF

March, 2019

**DISTRIBUTION STATEMENT A.**  
APPROVED FOR PUBLIC RELEASE; DISTRIBUTION UNLIMITED

**ANALYSIS AND DESIGN OF MODULAR OVERHEAD PROTECTION  
SYSTEM UTILIZING READILY AVAILABLE MATERIALS**

Zachary J. Spranger, BS  
Captain, USAF

Committee Membership:

Alfred E. Thal, Jr., PhD  
Chair

Maj Steven J. Schuldt, PhD  
Member

Elias Toubia, PhD  
Member

## **Abstract**

This research investigated passive overhead protective measures for existing facilities in an urban environment that are vulnerable to enemy munitions fire. A new modular structural system was designed utilizing commercially available construction material consisting of structural tubing, scaffolding clamps, base plates, and simple roofing components. Structural analysis software was used to model nine modular structures to understand the relationship between the load bearing capacity of the structural members and overall dimensions of the system. Environmental variables for the models were set to the Parwan Province in Afghanistan; this region presents worst-case scenarios both for environmental factors and threat of enemy fire. American Institute of Steel Construction, Unified Facilities Criteria, and American Society of Civil Engineer codes were used as design standards for the analysis. For the final design, the members were sized according to the maximum axial, shear, and flexural forces exposed to a single member. Preliminary findings show that commercially available materials can be used to quickly, efficiently, and cost-effectively install overhead protection in austere hostile environments. An economic analysis was conducted to determine if the size of members should be adjusted throughout the design to improve cost effectiveness. However, due to low marginal benefits, the structural tubing should be kept consistent throughout the design to simplify the construction process.

*Dedicated to my wife.*

## **Acknowledgments**

I would like to express my sincere appreciation to my research advisor, Dr. Thal, for his guidance and support throughout the course of this thesis effort. The insight and experience was certainly appreciated. I would, also, like to thank my sponsor, Mr. Nielsen, from the Air Force Civil Engineer Center for both the support and latitude provided to me in this endeavor.

I am also indebted to Dr. Toubia, from the University of Dayton, who spent his valuable time explaining principles of advanced structural engineering along with instruction to computer-based modeling software.

Zachary J. Spranger

# Table of Contents

	Page
Abstract .....	v
Table of Contents .....	viii
List of Figures .....	x
List of Tables .....	xii
List of Equations .....	xiii
I. Introduction .....	1
Background .....	1
Problem Statement .....	3
Research Objectives .....	4
Methodology .....	5
Assumptions and Limitations .....	6
Outline of Chapters .....	7
II. Literature Review .....	8
Brief History and Description .....	8
Overhead Protection System Composition .....	9
Facility Protection Research and Principles .....	9
Blast Effects .....	11
Facility Protection Practices and Methods .....	13
Modular Protective System (MPS) .....	14
Design of Engineered Resilient Systems .....	16
Utilization of Readily Available Materials – Constructability Centered Design .....	17
III. Methodology .....	20
Structural Analysis .....	20
ASCE 7-10: Nonbuilding Structures .....	21
Non-permanent Facility Requirements .....	22
Combination of Loads .....	24
Serviceability .....	25
Deflections .....	25
Live Loads .....	26
Wind Loads .....	26
Seismic Loads .....	29
Design Calculations .....	30

Flexural Buckling Compressive Strength .....	30
Design for Shear Strength.....	31
Design Members for Flexural Strength .....	32
Economic Analysis .....	34
IV. Analysis and Results.....	35
Results of Structural Analysis.....	35
Results of Structural Design .....	44
Economic Analysis .....	45
V. Conclusion .....	47
Findings Overview.....	47
Additional Research.....	48
Appendix A.....	50
Appendix B .....	55
Appendix C .....	60
Appendix D.....	65
Appendix E .....	66
Appendix F.....	67
Appendix G.....	68
References.....	69
Vita.....	72

## List of Figures

Figure	Page
1. ASCE Outline for Wind Calculations (ASCE, 2010).....	2828
2. 8' x 20' Isometric View .....	36
3. 8' x 20' Elevation View .....	37
4. 8'x 20' Plan View .....	38
5. Vertical Loading Diagram .....	39
6. Wind Load (X-Z Direction).....	40
7. 8' x 5' Elevation View.....	50
8. 8' x 5' Isometric View .....	50
9. 8' x 10' Isometric View .....	511
10. 8' x 10' Elevation View.....	51
11. 8' x 40' Isometric View .....	522
12. 8' x 40' Elevation View.....	522
13. 40' x 40' Isometric View .....	533
14. 40' x 40' Elevation View.....	53
15. 40' x 40' Plan View .....	544

## List of Tables

Table	Page
1. Loads and Basic Combination (ASCE, 2010) .....	24
2. Loading Conditions.....	26
3. Wind Load Parameters.....	28
4. Earthquake Loading Data (DoD, 2011).....	9
5. UFC 3-301-1 Wind Load Data (DoD, 2011).....	36
6. Model Numerical Descriptive Summary .....	41
7. Beam Summary Results (+).....	42
8. Beam Summary Results (-).....	43
9. Reactions Summary (+) .....	43
10. 8x10 Cost/SF Estimate.....	46
11. Design Cost Analysis.....	46
12. 8 x 5 Beam Summary.....	55
13. 8 x 10 Beam Summary.....	55
14. 8 x 20 Beam Summary.....	56
15. 8x40 Beam Summary.....	56
16. 40 x 40 Beam Summary.....	57
17. 96x20 Beam Summary.....	57
18. 96x40 Beam Summary.....	58
19. 192x20 Beam Summary.....	58
20. 192x40 Beam Summary.....	58
21. 8x5 Reaction Summary.....	60

22. 8x10 Reaction Table .....	60
23. 8x20 Reaction Summary .....	61
24. 8x40 Reaction table.....	61
25. 40x40 Reaction Summary .....	62
26. 92x20 Reaction Summary .....	62
27. 92x40 Reaction Summary .....	63
28. 192x20 Reaction Summary .....	63
29. 192x40 Reaction Summary .....	64
30. Flexural Buckling Compressive Strength .....	65
31. Shear Strength Calculations .....	66
32. Design Flexural Strength .....	67

## List of Equations

Equation	Page
1. ASCE 7-10 Wind Velocity Pressure.....	27
2. Slenderness Ratio.....	30
3. Elastic Buckling Stress .....	30
4. Elastic Buckling Critical Stress Test 1.....	31
5. Elastic Buckling Critical Stress Test 2.....	31
6. Nominal Flexural Buckling Compressive Strength .....	31
7. Design Flexural Buckling Compressive Strength.....	31
8. Shear Force Calculation.....	32
9. Maximum Shear Stress .....	32
10. Design Shear Strength.....	32
11. Limiting Diameter to Wall Thickness Ratio .....	33
12. Limiting Parameter for Slender Check ( $\lambda_p$ ) .....	33
13. Limiting Parameter for Slender Check ( $\lambda_r$ ).....	33
14. Limiting Parameter for Compact, Noncompact, and Slender Sections .....	33
15. Plastic Section Modulus.....	34
16. Plastic Moment Strength.....	34
17. Design Flexural Strength .....	34

# **ANALYSIS AND DESIGN OF MODULAR OVERHEAD PROTECTION SYSTEM UTILIZING READILY AVAILABLE MATERIALS**

## **I. Introduction**

United States military forces occupy regions around the globe that are under constant threat of enemy fire. Facilities at these locations are exposed to these indirect fire attacks from small arm, rocket, artillery, and mortar munitions. The majority of facilities used at these locations are neither constructed nor designed to withstand explosive attacks and therefore must be retrofitted with protective measures to adequately protect assets and personnel. This research further developed a possible solution for overhead protection on existing facilities. Overhead protection is a complex challenge due to the varying size, type, and locations of facilities to be protected. For this reason, a new modular design was based on the concepts of constructability and readily available materials. The goal was to reduce the time between requirement identification and requirement satisfaction by simplifying the materials and the complexity of the construction.

## **Background**

Currently, the United States (U.S.) has forward operating bases (FOBs) that are vulnerable to hostile threats of indirect fire (IDF). Indirect fire represents munitions fired by enemies, the most commonly being mortars and rockets, that do not have a specific target and are aimed at general areas of a base. These threats endanger the lives of service members and contractors deployed at these locations. While many of these threats can be mitigated by implementing safety procedures and physical barriers, one area that continues to be vulnerable is the overhead protection (OHP) of facilities. The purpose of OHP is to prevent catastrophic

damage to a building's external and internal structural frames (Ngo, Mendis, Gupta, & Ramsay, 2007). The nature of an explosion and mechanics of a blast wave inside a facility hinders timely evacuation and greatly increases the risk of death and injuries from debris impact, fire, and smoke (Ngo et al., 2007).

Overhead protection typically consists of two components working together: the pre-detonation screen and the shielding layer (Li, Summers, Clutter, & Bonaventure, 2012). Pre-detonation screens must be used in tandem with either an appropriate exterior wall/roof design or the installation of a shielding layer (Li et al., 2012). The overall goal is to ensure the safety and security of the occupants inside the facility by not allowing any perforation into the building envelope. Since the exterior walls of many existing facilities were never designed to handle a direct hit or act as a shielding layer, a completely new system must be created around the building envelop to protect occupants. This requires extensive resources and time to provide adequate protection for high-occupancy buildings. The effect of a rocket hitting an unprotected facility can be catastrophic.

The Engineering Research and Design Center (ERDC) has designed a modular pre-detonation screen meant to act as a quick reaction asset that can be deployed in hostile fire locations (Flores, 2012). This Modular Protective System (MPS) was developed for small expeditionary facilities (Flores, 2012). The basic structure consists of two composite armor panels, ballistic-grade E-glass panels and ultra-high-strength concrete panels with fiberglass facing, separated by a structural rodded system. This system was designed to not only stop direct fire from all sides but also provide OHP as well (Flores, 2012). The MPS is currently the only modular system that is readily deployable to hostile fire areas, but it has limitations which make it difficult to meet the needs of existing facilities. These limitations include, but are not limited

to, logistical lag times, acquisition costs, and a lack of large-scale application. Additionally, MPS was designed for contingency use and not retrofitting existing structures.

The former secretary of the Navy, Richard Danzig, explained that there is a lack of a clear existential adversary and that the Department of Defense (DoD) must be flexible and responsive its procurement activities (Danzig, 2011). The fluidity of long-term procurement programs must shift to focus on responsiveness, flexibility, and adaptability in the face of uncertainty. Most guidance relative to adaptation and flexibility in the military has been said as a generality, but the idea of adaptability has not been considered in the procurement and design of systems for the military (Wong, Pernin, Mikolic-Torreira, & Lewis, 2016).

Currently, there is a gap in protection for existing facilities within the hostile fire areas since there is no current modular OHP system. The only current option to protect these facilities is through the military construction (MILCON) process. MILCON requires both time and a certain degree of construction expertise, and both of these demands are typically in short supply at deployed locations. Therefore, there is a need for the design of a new modular protection system that can be used to retrofit various types of existing facilities and protect them from overhead impact.

## **Problem Statement**

Currently, the DoD does not have the complete solution to quickly and effectively protect existing facilities from overhead attacks. The current MPS designed by ERDC meets the construction timeliness factor but can only be used as a partial solution due to design limitations and a burdensome acquisition process. The MILCON process can handle large-scale existing facilities that cannot be protected by the MPS, but it is incredibly costly in the constrained

resource of time. MILCON requires long lead-times and may take multiple years from start to finish. For this reason, it is often not considered a viable option to combatant commanders to solve the overhead protection issue.

The Air Force Civil Engineer Center (AFCEC) requested that a modular OHP system be designed to help satisfy the gap in protection. The new design is meant to provide adaptive passive protection for existing structures to meet requirements of force protection in the urban environment (FPUE). The design is meant to only withstand overhead attacks from small arms, improvised explosive devices, rockets, artillery, and mortars. It is not intended to withstand any type of kinetic attack from larger conventional munitions, such as cruise missiles, ballistic missiles, or ordinance dropped from bombers.

## **Research Objectives**

What is the best solution to provide overhead protection for existing facilities in hostile fire locations? To answer this question, other questions need to be addressed as well. How do structural design requirements change with increasing and decreasing structure size? What are the marginal benefits of an economical design versus a design focused on constructability? This research attempted to answer these questions and progress towards a more universal OHP system of solution.

The primary objective of this research was to provide “proof of concept” for a new modular design to satisfy OHP requirements for existing facilities. Modular buildings reduce overall construction schedule, improve quality, and reduce resource wastage (Lacey, Chen, Hao, & Bi, 2018). The system will be a simple modular design using common construction materials either easily shipped or acquired on site. The final deliverable is a preliminary design, list of

materials, cost estimate, and structural analysis. This design should only be considered as a “proof of concept” since it was based on computational calculations and should undergo real-world testing prior to implementation. The goal was to provide an OHP structural design to AFCEC and ERDC so that strategic decisions can be made to operationalize either pre-built or on-site acquisition of OHP kits. This is the first step in utilizing commercial products for military contingency design; it will be a starting point for future research on the matter.

## **Methodology**

The methodology for the research relied on a computational structural design software program called structural analysis and design (STAAD®). This program was created by Bentley Systems, a software development company that creates programs to support the design of roadways, bridges, airports, skyscrapers, industrial power plants, and more. By utilizing this program, the calculated strengths of the members were found and designed to withstand the controlling external loads. Various OHP sizes were examined to understand the relationship between the size of the structure and the resulting loads. The standard design of the system was guided by Air Force Instruction (AFI) 1-201-01, Non-Permanent DOD Facilities in Support of Military Operations, as supplemented by the American Society of Civil Engineers (ASCE) 7-10, Designing Non-Building Structures, and the American Institute of Steel Construction (AISC) Steel Manual. The modular OHP system is auxiliary in nature, meaning that the existing facility will not need to be modified to support the addition of the system. This should streamline the design and enable quicker and easier acquisition and installation. Load factors were calculated for the Parwan Province in Afghanistan based on a facility that is 30 feet tall.

## **Assumptions and Limitations**

Key assumptions were made to limit the scope of this research to provide concise and significant results. Since the performance of material varies, so does the required stand-off distances. UFC 4-023-07, Design to Resist Direct Fire Weapons, shows that stand-off distances are only intended to defeat conventional rocket propelled grenade (RPG) munitions. Therefore, depending on the Area of Responsibility (AOR) and the given threats, these values may change. The minimum required stand-off distance was set to five feet, meaning that the lowest height of the pre-detonation screen will be five feet from the shielding layer on top of the exterior roof. This will simplify design and ensure a minimum level of service is achieved.

The next assumption is that only industry standard materials will be used in the design. This means that materials incorporated into the design will not require special fabrication prior to purchasing except for small on-site reduction in structural members and roofing components. All modifications to material will be able to be done on site and with simple tools by a standard craftsperson. Structural members will consist of structural tubing, also known as round Hollow Steel Structures (HSS), joined with scaffolding tube and clamp connectors. The roofing system will be attached to the structure's purlins and be a composite of ¾-inch plywood and steel roofing panels.

The base design model is an 8 feet x 20 feet section that is 30 feet high; this replicates a three-story building that is made of modified shipping containers used for standard habitation in deployed environments. The level of risk associated with an unprotected facility or the threat level of the hostile area will not be taken into consideration, meaning that this research does not prioritize which facilities need to be protected. It was also assumed that if the structure takes a direct hit from enemy munitions that the damaged parts are removed and reconstructed with new

materials. The survival of the pre-detonation screen structure was not considered important as long as the munitions were effectively thwarted.

The modular system is designed for the Parwan Province in Afghanistan; this location was chosen due to worst-case scenario wind loading conditions. This design is meant to fulfill contingency requirements and should only be constructed at home station units for the purpose of training. Additionally, this design was exploratory in nature; therefore, field tests should be conducted prior to inclusion in any type of instruction manual. An assumption was also made that the new OHP system was not designed to withstand the effects of a blast; in other words, the force of the explosion was not factored into the design of the modular structure.

## **Outline of Chapters**

The next chapter provides the literature review, which will explain OHP and the available systems that are currently in place. The end of the literature review will address the gap in capabilities that currently exists. The literature review will be followed by the methodology chapter, which will provide a detailed explanation of how the new modular system was analyzed and the equations used for steel member design. The fourth chapter will discuss the results of the analysis and provide preliminary recommendations for the modular structure. Finally, Chapter V will offer conclusions and briefly discuss potential follow-on research areas.

## **II. Literature Review**

This chapter begins with a brief history and description of Overhead Protection Systems (OHPs) and other basic means of protecting facilities from various types of enemy attacks. Following a basic description of OHP will be a more broad explanation of principles revolving around facility protective measures. Next will be the effects of blasts if they are not adequately stopped by protective measures and the potential impact they pose to inhabitants of the facility. Once the danger of blasts is known, the various protection practices and methods will be discussed to show that there is no single solution to protect inhabitants but more of a composition of levels of protection to ensure the safety of personnel. Next will be a review of the existing Modular Protective System (MPS) and the strengths and weaknesses of the product. Following the MPS review will be an explanation of the components of a resilient system. This will more accurately show the need for the design of a new system due to the gap of coverage that currently exists for overhead protection. Lastly will be the introduction of the use of readily available materials and the benefits of a design centered around the principle of constructability.

### **Brief History and Description**

Overhead protection in today's world is primarily used by oil operators and government entities in areas threatened by indirect fire attacks from terrorists (Li et al., 2012). The intent is to protect facilities that are occupied by personnel, such as dining, dormitory, and office buildings (Li et al., 2012). The need for development in protective measures is due to terrorist and paramilitary actions that are intended to do harm to U.S. military installations and civilian populated areas (Dinan, Coltharp, & Townsend, 2002). During 2004-2005, the United States

Army Corps of Engineers (USACE) Engineering Research and Development Center (ERDC) accomplished several tests that provided basic guidance to combatant commanders to enhance the process of protecting a facility from such threats (Genelin & Nelson, 2011). In 2009, the Air Force Research Laboratory (AFRL) initiated a multi-phased investigation, specifically for pre-detonation of incoming explosive projectiles, with the intent to expand upon knowledge through the means of additional testing of new and existing materials aimed to defeat threats posed by mortars and rockets (Genelin, 2011; Genelin & Jordan, 2010; Genelin & Nelson, 2011). Next, the overall composition of OHP system and its key components will be discussed.

### **Overhead Protection System Composition**

OHP systems consist of two layers: a pre-detonation layer and a shielding layer (Li et al., 2012). The purpose of a pre-detonation screen is to initiate the fuse of the incoming munition, which will help mitigate the blast effect of the weapon. The shielding or protection layer is located below the pre-detonation layer and provides ballistic resistance against fragmentation perforation (Genelin & Nelson, 2011). The primary purpose of the shielding layer, as mentioned earlier, is to stop the fragmentation from an exploded munition. A shielding layer can consist of any type of material as long as it is designed to stop perforation. Adjustments to the type of material and the required thickness will depend on the size of munition, assuming that the munition is in fact detonated by the pre-detonation screen above.

### **Facility Protection Research and Principles**

Research in passive facility protection has been prevalent for decades; in 2000, the U.S. Army Engineer Research and Development Center, Geotechnical and Structures Laboratory,

participated jointly with the U.S. Air Force Research Laboratory, Israeli Air Force, Israeli Corps of Engineers, and Israeli Home Front Command to test various types of conventional walls to determine some level of protection for occupants (Dinan et al., 2002). The test was meant to examine “near miss” detonations of Katyusha 122mm rockets. The results of the experiment were determined from photographs and by observing fragment penetration and the overall level of protection provided by the wall (Dinan et al., 2002).

The first objective of the experiment was meant to determine a baseline for the selected conventional wall’s capacity for defeating fragment penetration. The second objective was to determine the effectiveness of retrofitted walls and their ability to resist fragment penetration. A total of 14 wall targets were testing at varying stand-off distances ranging from five to six meters and two to four meters. The tested walls consisted of compositions of material such as brick veneer, wood studs, single concrete masonry unit (CMU), sand-filled CMU, and grout-filled CMU. It was found that “the intuitive principles of greater wall-mass and higher material-strength were evident from the test results as the primary factors contributing to fragment resistance” (Dinan et al., 2002).

From the experiment, Dinan et al. (2002) concluded that the worst performers for resistance to fragment perforation were walls with empty cells, which were wooden studs and unfilled CMUs. They also found that an air gap between the existing wall and the added retrofit-wall does not improve resistance to fragment perforation. Their experiment was important due to the findings that were relevant to the shielding layer. They also identified important concepts and principles that are essential to resistance to fragment perforation. Although their research only tested conventional exterior walls, the principles that were learned can be used in OHP designs, particularly with the shielding layer of the system.

A test series designated “Desert Cobra” was conducted to test protection specifically against indirect fire weapons, such as rockets, artillery, and mortars (Genelin & Nelson, 2011). This experiment was done under the Agreement Concerning Combating Terrorism Research and Development between the U.S. Department of Defense (DoD) and the Israeli Ministry of Defense. More specifically, it was managed by the Technical Support Working Group with respect to the Dynamic Effects of Indirect Firing Munitions within the DoD’s Combating Terrorism Technical Support Office (Genelin & Nelson, 2011). The study focused primarily on the pre-detonation of large caliber mortars to analyze the performance of readily available construction materials for use as pre-detonation layers. Previous studies had several anomalies and this study was meant to expand the database of recommendations for pre-detonation materials (Genelin & Nelson, 2011). Several common construction materials were tested along with other lightweight alternatives to measure their effectiveness for expedient use in forward deployed environments under threat of hostile indirect fire. A total of 48 Iranian M48 mortars fitted with AZ-111-A2 fuses were horizontally fired into 17 different pre-detonation layers (Genelin & Nelson, 2011). The original research from AFRL, Overhead Protection for Expeditionary Shelters: Phase One and Two, produced anomalies for certain pre-detonation materials and munition types which is why the Desert Cobra tests were conducted. The results of the evaluation supported the claim that insufficient arming distance was the likely explanation for previous AFRL test anomalies (Genelin & Nelson, 2011).

### **Blast Effects**

The consequences of a blast effect, also known as an extreme loading event, are catastrophic and almost certainly lead to structural failure that results in personnel injuries and

fatalities, economic loss, and immeasurable social destruction (Hao, Hao, Li, & Chen, 2016). There are three distinct categories of explosions: physical, nuclear, and chemical (Ngo et al., 2007). In physical explosions, energy is typically released from the catastrophic failure of a cylinder of compressed gas, volcanic eruption, or mixing of two liquids (Ngo et al., 2007). In a nuclear explosion, the release of energy is caused by the formation of different atomic nuclei by the redistribution of protons and neutrons within the interacting nuclei (Ngo et al., 2007). Chemical explosions occur when there is rapid oxidation of fuel elements, typically carbon and hydrogen (Ngo et al., 2007).

For this research, the primary concern is for physical explosions due to the threat of the blast overpressure and primary or secondary fragments of a direct impact. Secondary concerns are the indirect effect of the damage that could lead to structural collapse and even greater loss of assets and lives. Structural collapse would lead to the greatest loss; therefore, it is imperative that structural engineers and policy regulators are made aware of the threats to buildings (Hao et al., 2016). Structural collapse is the result of an idea called “progressive collapse,” and American National Standards Institute (ANSI) A58.1-1982 contains minimum design loads for buildings and other structures (Ngo et al., 2007). This standard recommends an alternative path method, meaning that in the case of failure for a primary structural member there should be a second path for the load to travel to prevent immediate collapse. This means that in the case of the local failure of a member, due to damage from explosion, there will be an alternative structural member for the load to transfer to, instead of a complete structural collapse occurring. The effects of a blast can be catastrophic towards any facility. Unfortunately most existing facilities within the expeditionary environment were not designed to meet progressive collapse standards, which only emphasizes the need for overhead protection. Next, the current practices

and guidance being implemented to protect new and existing facilities under threat of hostile fire will be discussed.

### **Facility Protection Practices and Methods**

Blast loads on a structure are dependent on the explosive material, weight and shape of the explosive, distance and location of the explosive, and interaction of the blast wave with the ground and structure. The relevant parameters of a blast effect are dependent on the amount of energy released (DoD, 2014). The Hardened Installation Protection for Persistent Operations (HIPPO) Joint Capability Technology Demonstration developed and validated a scalable, resilient structured solution to ensure continuity of operations after major attacks (Hammons, Kensky, Dinan, and Duval, 2012). There is an emphasis placed on the capabilities required to support and conduct sortie generation, which includes the ability to recover, refuel, re-arm, unload-load, and launch aircraft and the systems that enable these activities. Examples of facilities that HIPPO is meant to support include fuel storage and distribution, munitions delivery, and command and control (Hammons et al., 2012). The following represents the products that HIPPO delivered to bolster resilient structures in the DoD (Hammons et al., 2012): a range of proven (weapons effect tested) sheltering methods and improved survivability capabilities for critical systems; a set of residual repair and restoration equipment and materials; capabilities and benefits of various hardening methods with expected cost considering threat, location, and mission; an independent report of demonstrated operational utility; and a Concept of Operations (CONOPS) document that addresses processes to achieve the maximum combined effect to support persistent operations at the installation level. Overall, HIPPO delivers

engineering criteria in the form of material selection and structural design that can only be easily applied to new Military Construction (MILCON) projects.

### **Modular Protective System (MPS)**

Modular systems are commonly used in expeditionary settings where rapid construction is a key principle to the success of the operation. The Modular Protective System (MPS) designed by ERDC is a technology-based solution to provide protection for the warfighter and is reusable. MPS is a lightweight space frame that utilizes composite armor panels. The system has been validated for protection against small arms, rockets, mortars, blast loading, and direct fire rockets. The components are simple and designed for constructability while still being easily erected by one- or two-person work crews. The system offers protection through a multi-layered panel system in which the primary components are E-glass and ultra-strength concrete panels. Since the system is modular in nature, it can be tailored to fit the protection needs required for the anticipated threat level. Some of the key benefits to this system are: (1) proven protection from rockets and mortars, (2) rapid construction, (3) modular and scalable configurations, (4) no special tools required for construction, (5) easy reconstitution, (6) configurable according to required level of protection, and (7) overhead cover (OHC) protects from direct hit mortar attack (ERDC, 2012). MPS can be used for multiple scenarios; some key applications that will be discussed in more detail are expedient barriers, mortar pits, guard towers, and overhead cover.

The MPS wall is best suited for perimeter lineation while providing protection from small arms, indirect fire, RPGs, and blast threats. A 100-foot long by 8-foot tall wall can be constructed by a five-person team in less than 3.5 hours. It can be up to 12 feet tall and can be

installed on uneven terrain. All materials for the MPS wall, similar to all MPS systems, are held in easily transportable type II Tricon containers (ERDC, 2012).

The components were designed to be able to protect critical mortar pits. Typically, a mortar position must be protected from enemy counter-fire by either digging or building protective structures. The MPS mortar pit allows quick deployment and recovery of the asset if the mortar position must be relocated quickly. The system is smaller than other MPS systems and can be transported via helicopter in situations requiring remote mortar positions (ERDC, 2012).

The MPS multi-purpose guard tower is a rapidly deployable system that will provide overwatch capabilities for entry control points and perimeter protection. It may be constructed either in an elevated or ground-level fighting position depending on the needs of the installation. Guard towers are a vital element for base defense and are often one of the first features installed for perimeter security. Conventional construction of guard towers requires engineering support, considerable manpower, construction material resources, and time (ERDC, 2012), all of which may not be available during FOB bed-down operations.

The MPS overhead cover (OHC) product provides overhead protection from direct hit mortars and rockets. The system is scalable and allows for some flexibility in design depending on the size of the facility. MPS-OHC can be adapted to connect to expedient walls, such as soil-filled containers and reinforced concrete walls. It can be taken down and re-used easily and is a stand-alone structure to use over existing assets (ERDC, 2012). It is important that it is a stand-alone structure, so no additional design work needs to be done since it does not add any additional forces to the facility or asset that it is protecting. Some limitations to the system are that it can only be constructed up to 27.5 feet long with no special tools or heavy engineering

equipment. A 47.5-foot MPS OHC may be constructed with the aid of a standard military 10k forklift. Additionally, the height of the system is limited to 12 feet (ERDC, 2012).

Overall, the MPS system is a versatile, quick-deploying system that can be built from military assets and used for FOBs. The MPS products may be effective at providing specific protection for designated military structures, but it is difficult to adapt the MPS system to existing facilities due to its strict modularity and structural limitations. The MPS system cannot be altered easily to meet varying facility requirements without engineering design efforts.

### **Design of Engineered Resilient Systems**

Resilience is a common theme in many fields, but measuring it depends largely on the problem or external threats that are being mitigated (Goerger, Madni, & Eslinger, 2014). A workshop co-sponsored by the Military Operations Research Society (MORS) and Argonne National Laboratory defined resilience as “the ability of an entity – e.g., asset, organization, community, region – to anticipate, resist, absorb, respond to, adapt to, and recover from a disturbance from either natural or man-made events” (Hummel, Kerner, Petit, & Thomas, 2014). More specifically for OHP systems, Neches and Madni (2011) define resilience as “the ability of a system to adapt affordably and perform effectively across a wide range of operational context, where context is defined by mission, environment, threat and force disposition.”

According to Goerger et al. (2014), there are four key properties of a resilient DoD system: repel/resist/absorb, recover, adapt, and Broad Utility. It is at the intersection of two or more of these properties where one can find the most optimal solution for a particular problem. Resilience with respect to the DoD is a system with the ability of a family of products to effectively meet a variety of missions with multiple outcomes through rapid configuration

despite the uncertainty of an individual component's performance (Neches and Avent, 2011). Resilience can be achieved by exploiting couplings between micro systems whose interactions serve as a macro capability that satisfies mission objectives (Goerger et al., 2014). For example, Goerger et al. (2014) uses an example of multiple self-configuring cooperating sensors that worked tandemly as data collectors by "swarming." The result was a macro system which was capable of being adjusted by each sensor as the environment changed over time. The analysis of such individual components needs a process within which the system operates, meaning there needs to be an adaptive trade space analysis based on the purpose of the capability and the mission in which it is expected to be used (Goerger et al., 2014). Furthermore, Goerger et al. (2014) goes on to explain how a system is designed to meet the desired end-state of an operation and still be available for future operations; additionally, disposable systems may be used in resource constrained environments. Resilient DoD systems need to leverage new technologies and techniques as they emerge to meet changing requirements and conform to new environments (Goerger et al., 2014).

This is similar to what MILCON, MPS, and interior and exterior protective measures are doing for assets and facilities. These protective solutions have been developed extensively, but there are still gaps in protection that could be addressed by using a more resilient tool like the OHP. Additionally, using readily available material to construct the OHP could offer a more resilient solution to overhead protection.

### **Utilization of Readily Available Materials – Constructability Centered Design**

Using readily available materials to construct a modular design of OHP could result in a disposable system that is able to satisfy protection requirements for facilities. A system based on

readily available materials revolves around the principle of “ease of construction.” Instead of having a modular product that follows more rigid guidelines, a modular design will be able to meet more requirements due to its relative flexibility; it could also be scaled up or down by more precise measurements according to facility parameters.

According to O’Connor, Rusch, & Schulz (n.d.), constructability is when the optimum use of construction knowledge is used during planning, engineering, procurement, and field operations to achieve an effective product in a timely manner. One aspect that is particularly important to expeditionary forces in deployed locations that greatly affects time is the procurement process and how materials are shipped. However, using local materials can reduce acquisition time along with environmental impacts of the construction. A design that utilizes more readily available material can also enhance procurement schedules (Morel, Mesbah, Oggero, & Walker, 2001; O’Connor, Rusch, & Schulz, n.d.).

Simplified designs are configured to enhance efficient construction. Some guiding principles to a simplified design are as follows: (1) minimum number of components, elements, or parts for assembly, (2) using readily available materials in common sizes and configurations, (3) easy to execute connections with minimum requirements for highly skilled labor and special environmental controls, (4) designs which allow for field capability for dimensional adjustment, (5) employing designs which minimize construct task interdependencies, and (6) choice of materials and required connecting arrangements (O’connor et al., n.d.).

Designs should be reviewed by qualified personnel, and project organization and execution plans should include all parties involved in the design and the construction aspect. The best implementation of simplified designs is when people involved at all levels of

construction are routinely discussing how principles involved in the work directly relate to their part of the project (O'Connor et al., n.d.).

Standardization of design elements may also greatly enhance constructability by taking advantage of repetition. Savings on time, material, and manpower can be realized when the number of variations is kept to a minimum. Items of construction that can be standardized to increase field efficiency are building systems, material types, construction details, dimensions, and elevations. The advantages of standardization may appear in the following ways: (1) quicker learning curve and enhanced productivity from repetitive operations, (2) discounts from volume purchase since the same types and sizes of materials are used, and (3) the procurement process and material management of construction projects is simplified due to less complexity of materials required for construction (O'Connor et al., n.d.). An additional bonus to contingency construction is the lack of importance placed on aesthetics. This should be considered a benefit since it is one less constraint to affect an already complicated construction process in contingency environments.

### **III. Methodology**

Zareh B. Gregorian states that “Every structure built and loaded in nature, no matter how insignificant, must be constructed according to the law of gravity and the principles of structural mechanics.” This chapter describes the methodology used to design a new modular overhead protection system made of readily available materials and is able to support itself. Computer-based finite element analysis was the primary method of research used. The first section is a structural analysis overview, which describes the standards applied to the design. Next is the classification of the facility followed by the requirements of the non-building structure classification. The classification dictates which codes govern the design of the structure. Finally, the combination of loads and the assumptions for the variables associated with serviceability, deflection, live loads, wind loads, and seismic loads are explained. Following the explanation of governing codes will be the equations used to calculate shear, compression, and flexural load requirements for structural members. Lastly will be a brief explanation of an economic analysis of marginal benefits depending on the design members selected. Possible biases and shortcomings for each method will also be addressed in each section.

#### **Structural Analysis**

The goal was to complete a modular design that was a structurally viable product capable of withstanding exposure forces and providing effective overhead protection. Structural analysis modeling software was used to identify critical members for the various sizes of the modular system. The advancement of computers has enabled structural analysis software to be an acceptable method for the analysis of complex structures. Due to the modularity of the structure,

there are many member stresses that change when varying the structure size. The primary codes used to ensure the design meets regulatory requirements were the American Society of Civil Engineers (ASCE) Standard 7-10, Minimum Design Loads for Buildings and Other Structures, and UFC 1-201-01, Non-permanent DoD Facilities in Support of Military Operations. These codes guided the principles of design and eventual analysis of the structure. The difference between design and analysis needs to be addressed to understand the process of developing an overhead protection system. Analysis involves the distribution of loads in a structural model to determine the reactions and internal stresses being applied by outside forces, while the design portion involves determining member sizes, configuration, and connections using the results of the analysis (ASCE, 2010). The standard codes used for the analysis of the structure are discussed next.

### **ASCE 7-10: Nonbuilding Structures**

The modular structure was classified as a nonbuilding structure for a number of reasons. According to the ASCE, a nonbuilding structure can be either an appendage or a component. An appendage is an architectural component, such as a canopy, marquee, ornamental balcony, or statuary. A component is a part of an architectural, electrical, or mechanical system (ASCE, 2010). ASCE further described a nonbuilding structure to be any self-supporting structure that carries gravity loads and that may also be required to resist seismic loads (ASCE, 2010). In a more easily understood manner, a nonbuilding structure is designed and constructed in a manner similar to a building; it will respond to ground motion similar to a traditional building and has a basic lateral force resisting system.

Chapter 26 of ASCE 7-10 defines an open building as one having at least 80 percent of its walls open. For each wall, this is expressed by the equation  $A_o \geq 0.8A_g$ , where  $A_o$  is the area of the openings in the wall and  $A_g$  is the gross area of the wall. Since no walls are present in the structure being designed, the equation representative of the components and cladding structure is  $A_o = A_g$ . A main wind force resisting system (MWFRS) is an assemblage of structural elements assigned to provide support and stability for the overall structure; in the case of an auxiliary overhead protection system, it does not provide any additional stability to the building it is protecting. It is important to adequately designate the type of structure being designed since applicable codes may vary greatly depending on the classification of the structure. For the purpose of this research's methodology, the nonbuilding structure was best designated as a "components and cladding" structure due to the relative openness of the structure and the fact that the structure does not contribute to the MWFRS of the building it is designed to protect.

### **Non-permanent Facility Requirements**

Once the design was categorized as nonbuilding components and cladding structure subjected to basic loading requirements, it required further structural designation relative to facility use in support of military operations. UFC 1-201-01, Non-Permanent DoD Facilities in Support of Military Operations, provides life, safety, and habitability-related design requirements for non-permanent facilities designed and constructed for use by the DoD. UFC 1-201-01 was developed to establish the minimum requirements necessary for life safety while allowing for expeditionary construction to more effectively enable mission requirements. The UFC outlines three construction levels for non-permanent facilities: initial, temporary, and semi-permanent.

The design for the new modular pre-detonation screen was considered to be temporary since its life expectancy is less than 5 years and it uses low-cost, readily available construction materials.

The requirements for temporary non-permanent facilities are outlined in Chapter 1 and Chapter 3 in UFC 1-201-01. Chapter 1 outlines the required analysis and documentation needed for temporary facilities. The required submittals are civil, fire protection, structural, plumbing and mechanical, and electrical. Due to the nature of the non-building structure, the only required analysis was the structural submittals. Chapter III outlines the facility classification assumptions, load generation, and structural design calculations.

The design is based on the codes prescribing limitations of serviceability, deflections, and load generation. Column design and framing plan are similar for this structure due to the modularity of all components. Columns and normal framing members were originally designed to be identical structural members but may change depending on the results of the analysis. Similar to columns and framing members, lateral design considers the distribution of loads resulting from lateral forces and originally used identical members, similar to columns and beams. Lateral bracing members were positioned in both  $x$  and  $y$  directions within the Cartesian coordinate system, in which  $x$  and  $y$  designate the length and width, respectively. All beams and columns were joined with pinned connections as opposed to fixed moment resisting connections to simplify construction. The structure was designed in accordance with the International Building Code (IBC) 2009 Edition, ASCE/SEI 7-10 Minimum Design Loads for Buildings and Other Structures, UFC 3-301-01 Structural Engineering, UFC 3-310-04 Seismic Design for Buildings, and UFC 1-201-01 Non-Permanent DoD Facilities in Support of Military Operations. Design exceptions outlined in UFC 1-201-01 were used to reduce construction complexity;

additionally, the design parameters discussed below were significantly amended and will be discussed in following sections.

### Combination of Loads

The structural load analysis selected for this research was the Load and Resistance Factor Design (LRFD) method. This method uses the calculated material strength with load factors to determine structural integrity. It also uses load and resistance factors to account for material property variability when defining loads and inaccuracies in the design theory itself (ASCE, 2010). Table 1 shows all the variable loads and combinations used to analyze the structural system. The analysis only utilized the basic loading conditions outlined in ASCE/SEI 7-10. Considered in the analysis were the dead ( $D$ ), live ( $L$ ), roof live ( $L_r$ ), snow ( $S$ ), wind ( $W$ ), seismic ( $E$ ), and rain ( $R$ ) loads. The benefits of using the LRFD method are that it is consistently reliable, helps the designer have a better understanding of the actual behavior of the structure, and can be used as a tool for decision-making for existing structures. The primary shortcomings of this method are that designers have to convert results to service levels when examining foundations and issues regarding principles of serviceability.

Table 1. Loads and Basic Combination (ASCE, 2010)

Load	#	Load Combination
$D=$ Dead Load	1	$1.4D$
$L=$ Live Load	2	$1.2D + 1.6L + 0.5(L_r \text{ or } S \text{ or } R)$
$L_r=$ Roof Live Load	3	$1.2D + 1.6(L_r \text{ or } S \text{ or } R) + 0.5(L \text{ or } 0.5W)$
$S=$ Snow Load	4	$1.2D + 1.0W + L + 0.5(L_r \text{ or } S \text{ or } R)$
$R=$ Rain Load	5	$1.2D + 1.0E + L + 0.2S$
$W=$ Wind Load	6	$0.9D + 1.0W$
$E=$ Earthquake Load	7	$0.9D + 1.0E$

### *Serviceability*

Frame drift will not be limited to prevent damage to non-structural elements of the structure. This is assuming that there is no damage sustained from frame drift that could possibly create unsafe conditions for personnel in or around the structure. For this specific design, this means that any non-structural elements, such as roof components, will not be assessed for drift. This simplified the design by lessening strength requirements and minimizing connections to the roofing system.

### *Deflections*

Deflections are typically governed by both IBC section 1604.3.2 through 1604.3.5 and UFC Table 2-1 of UFC 3-301-01; however, UFC 1-201-01 states that member deflections can exceed allowable limits of the material if the following requirements are met: (1) the increased deflection does not cause excessive rotations in connections at ends of members that could result in connection failure, and (2) the increased deflection does not create an unsafe condition where finishes or other non-structural items could become dislodged and fall on personnel. For this particular design, condition one is met since all connections are pinned and only undergo minor rotational forces; therefore, the structure should not fail as a result of excessive joint rotation. Condition two is met since the structure is an auxiliary structure and is detached from the structural support system of the primary structure, thus personnel will be clear from any excessive deflecting members. This exception to deflection is limited to an absolute maximum allowable deflection of  $L/120$ , in which  $L$  is equal to the span of the individual member. All members in all modular designs were tested to meet the deflection limits.

### *Live Loads*

Although UFC 1-201-01 allows for the reduction of live loads specified by IBC codes, a roof live load of 20 pounds per square foot was maintained. This weight is in addition to the dead load resulting from the roofing components. Table 2 shows a list of the loading conditions applied to the design. The live load was not reduced due to the uncertainty of construction constraints for modular systems. Additionally, environments or facility size could impact structure erection practices; therefore, a larger roof live load was used for the analysis as opposed to a more conservative load to provide an additional factor of safety.

Table 2. Loading Conditions

Type	Load (psf)	Notes:
$D$ (Dead Load)	15	Dead load accounts for weight of roofing system, components loads were overestimated due to material acquisition uncertainty in these regions
$L_r$ (Roof Live Load)	20	Roof load is unreduced due to structures variation of size and ambiguity of construction challenges to be faced during installation
$L$ (Live Load)	-	No live load expected on the roof
$W$ (Wind Load)	Varies	Wind load changes based on height and size of structure, please review chapter 4: Analysis and Discussion for final Wind load calculations
$S$ (Snow)	-	No snow loads are anticipated in this region for design.
$R$ (Rain)	-	Not considered due large $L_r$ which governs basic load combinations

### *Wind Loads*

Wind speeds cannot be ignored due to the selected base wind speed of the region for which the structure is designed. This particular structure is designed for the Parwan Province in Afghanistan with a starting elevation of 30 feet, since it typically will sit on top of existing structures. This height is equivalent to a triple stack of shipping containers that is typically used

as housing for military and contracted personnel. Wind calculations have a considerable number of variables, and the following paragraphs explain the process used to calculate wind speeds. Figure 1 shows the overall approach to how wind loads are calculated. Equation 1 shows the wind pressure calculation at a given height ( $q_z$ ); each variable is linked to parameters regarding the facilities location, size, type, and surrounding landscape.

$$q_z = 0.00256K_zK_{zt}K_dV^2 \left( \frac{\text{lb}}{\text{ft}^2} \right) \quad (1)$$

$K_z$ , the velocity pressure exposure coefficient, is based on the facility's height above ground level and the designated exposure category. The exposure variable is relative to the surface roughness around the proposed structure. Since this design is modular and exposure may vary from location to location, the most common exposure category, exposure C, was selected for the analysis.  $K_{zt}$  is a topographical variable that is based on the facility's relative location with respect to three-dimensional or two-dimensional escarpments. Since the typical location represents a flat and level surface, as opposed to the tops of hills and escarpments,  $K_{zt} = 1.0$  with neither increased nor decreased wind velocity pressure.  $K_d$ , the wind directionality factor, is based on the shape of the structural components exposed to wind forces. Since the structure was previously classified as a components and cladding building, and according to Table 26.6-1 in ASCE 7-10, the directionality factor is 0.85. The basic wind speed ( $V$ ) given for the region is given in Table 3 as 100 mph for a Risk Category I, which designates facilities that have little to no occupancy. These variables were used to calculate wind loads that were used for the design of all the pre-detonation structures modeled in the structural software. Table 3 also provides a summary of the selected parameters used for calculations.

Table 3. Wind Load Parameters

Variable	Value	Description
$K_z$	Varies	Changes based on facility height and exposure category
$K_{zt}$	1.0	Topographical variable adjusting wind loads with local elevation changes
$K_d$	0.85	Directionality variable, dependent on shape of structure of material
$V$	100	Basic wind speed based on empirical data

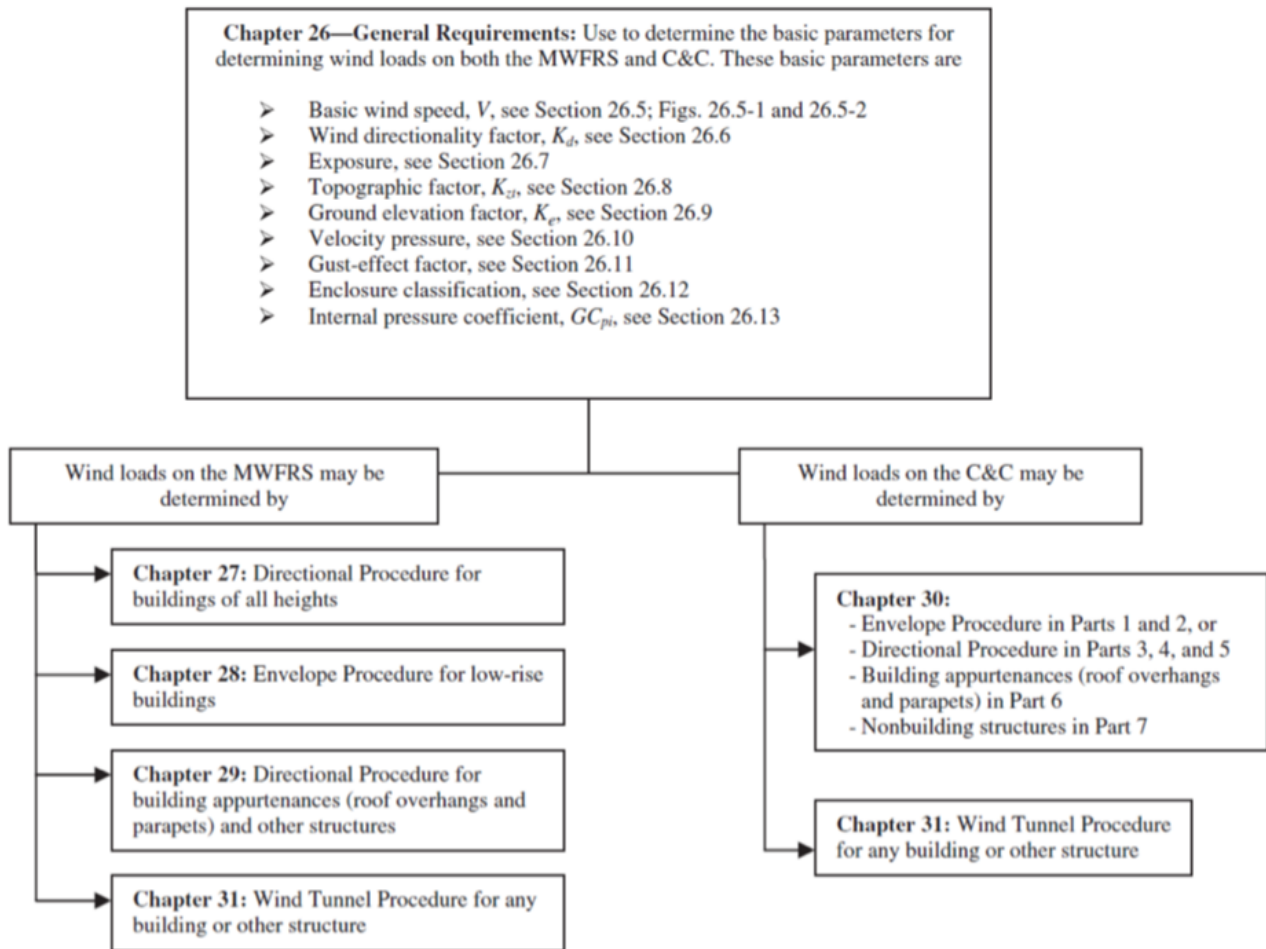

FIGURE 26.1-1 Outline of Process for Determining Wind Loads

Figure 1. ASCE Outline for Wind Calculations (ASCE, 2010)

## Seismic Loads

Due to the complexity of seismic parameters dependent on the supporting facility, seismic loads could not be simplified to support modular design. Seismic analysis, along with using the structural engineering UFCs and ASCE/SEI 7-10 Chapter 12, are recommended if the following parameters are met:  $S_s \geq 0.55$  and  $S_1 \geq 0.13$  and facility occupancy categories are either I, II, or III (ASCE, 2010; DoD, 2011). If  $S_s$  is  $\geq 0.32$  and  $S_1$  is  $\geq 0.08$  for occupancy category IV, no reduction should be given and a seismic design is necessary. Table 4 shows seismic data for the specific region (DoD, 2011).

Table 4. Earthquake Loading Data (DoD, 2011)

**Table F-3**

Continent / Region	Country	Base / City	Seismic Data (Site Class B)								
			PGA (%g)	$S_s$ (%g)	$S_1$ (%g)	$S_{S,5/50}$ (%g)	$S_{1,5/50}$ (%g)	$S_{S,10/50}$ (%g)	$S_{1,10/50}$ (%g)	$S_{S,20/50}$ (%g)	$S_{1,20/50}$ (%g)
Africa	Tanzania	Dar es Salaam	7	18	8			9	4		
		Zanzibar	5	12	6			6	3		
	Togo	Lome	15	39	19			21	10		
	Tunisia	Tunis	36	95	45			50	24		
	Uganda	Kampala	18	46	22			24	11		
	Zambia	Lusaka	9	23	11			12	6		
	Zimbabwe	Harare	2	6	3			3	1		
Asia	Afghanistan	Bagram	66	146	84			73	35		
		Gardeyz	26	63	30			35	17		
		Herat	26	62	32			16	5		
		Jalalabad	45	106	39			59	21		
		Kabul	48	111	58			61	28		
		Kandahar	13	32	19			18	10		
		Lashkar Gah	7	16	11			9	5		
		Mazar-e Sharif	33	78	27			41	15		
		Pol-e Charkhi	42	100	47			57	26		
		Qalat	35	79	45			41	20		
	Bahrain	Manama	11	28	13			15	7		
		NSA Bahrain	12	32	15			17	8		
Bangladesh	Dhaka	28	73	34			38	18			
Brunei	Bandar Seri Begawan	15	39	18			20	10			

## Design Calculations

The design was in accordance with AISC Steel Manual Edition Chapter E Specifications (AISC, 2011). All members selected for design were round hollow steel structure (HSS) with nominal diameters less than two inches. The steel selected was ASTM A500 Grade C, which is the most common steel used for round HSS. The controlling required strength for compressive, shear, and flexural values occurred in the columns of the design; therefore, the design parameters used were for the 6-foot columns within the design. Each strength category follows a set of equations based on the parameters of the column. Each respective strength category has Appendixes showing the final calculated design values of all members tested.

### *Flexural Buckling Compressive Strength*

The first calculation used to find compressive strength was the slenderness ratio equation (AISC, 2011),

$$\text{Slenderness Ratio} = \left( \frac{KL}{r} \right) \quad (2)$$

where  $K$  represents the effective length of the member,  $L$  is the uncompressed length, and  $r$  is the radius of gyration. All dimensions and properties for the round HSS members were gathered from Table 1-13 in the AISC steel manual (AISC, 2011). The slenderness ratio is a numerical value to determine the flexural behavior that a given member will experience depending on the parameters of its loading condition. This ratio was used to determine which critical stress ( $F_{cr}$ ) equation to use later to calculate the final design compression strength. After determining the slenderness ratio, the Elastic Buckling ( $F_e$ ) stress was found using equation 3, where  $E$  is the variable modulus of elasticity and has a value of 29,000 KSI.

$$F_e = \left( \frac{\pi^2 E}{\frac{KL^2}{r}} \right) \quad (3)$$

Once the elastic buckling stress was calculated, the condition of the critical stress had to be tested against two equations to determine which  $F_{cr}$  equation should be used. Equations 4 and 5 show the tests along with the resulting  $F_{cr}$  that should be used.

$$\text{If } \frac{KL}{r} \leq 4.71 \sqrt{\frac{E}{F_y}} \text{ then use } F_{cr} = \left[ 0.658 \frac{F_y}{F_e} \right] * F_y \quad (4)$$

$$\text{If } \frac{KL}{r} > 4.71 \sqrt{\frac{E}{F_y}} \text{ then use } F_{cr} = 0.877 * F_e \quad (5)$$

For this design, the  $\left(\frac{KL}{r}\right)$  factor was greater than 4.71; therefore, equation 5 was used to calculate  $F_{cr}$ . The final step included the calculation of nominal and design compressive strength using Equation 6.

$$P_n = \left( \frac{\pi^2 E}{\frac{KL^2}{r}} \right) \quad (6)$$

The nominal compressive strength must still be altered to account for the factor of safety according to the LRFD method. For flexural buckling compressive strength, it is multiplied by the constant  $\Phi = 0.90$ , which can be seen in Equation 7.

$$\Phi P_n = 0.90 * P_n \quad (7)$$

### *Design for Shear Strength*

AISC Chapter G and finite element analysis were used for shear stress calculations (AISC, 2011; Hoogenboom & Spaan, 2005). This analysis was simplified since little

information is available on round HSS subjected to transverse shear. This is partly due to the minimal impact shear has on the design of round HSS except in the case of thin sections with short spans (AISC, 2011). To calculate the value of shear force at the section, Equation 8 is used (Hoogenboom & Spaan, 2005).

$$V = \int_{s=0}^{2\pi r} F_y * t * ds * \cos\theta \quad (8)$$

The variable  $F_y$  represents the yield strength, while  $t$  denotes the tube thickness and  $ds$  is part of the circumference. Once the shear force is calculated, the maximum shear stress ( $\tau_{max}$ ) can be calculated from Equation 9.

$$\tau_{max} = V_n = 2 * \frac{V}{A_g} \quad (9)$$

The final step is to apply the resistance factor to calculate the actual strength of the member.

This step is similar to the final step done in the compressive strength calculation except that  $\Phi = 0.6$  for LRFD standards as seen in equation 10.

$$\Phi V_n = 0.6 * V_n \quad (10)$$

### *Design Members for Flexural Strength*

The design for flexural strength was in accordance with AISC Steel Manual Edition Chapter F Specifications (AISC, 2011). All members selected for design were consistent with the previous shear and compressive strength design. The first calculation used to find flexural strength was to ensure the actual diameter to wall thickness ratio is less than the limiting diameter to wall thickness ratio, given by Equation 11, where  $D$  is the nominal diameter and  $t$  is the thickness.  $E$  and  $F_y$  are the same variables mentioned in earlier design discussion.

$$\left(\frac{D}{t}\right)_{\text{limit}} = \frac{0.45E}{F_y} \quad (11)$$

$$\text{Ratio Check } \left(\frac{D}{t}\right)_{\text{actual}} < \left(\frac{D}{t}\right)_{\text{limit}} \text{ "D/t Ratio Ok"}$$

$$\text{Ratio Check } \left(\frac{D}{t}\right)_{\text{actual}} \geq \left(\frac{D}{t}\right)_{\text{limit}} \text{ "D/t Ratio Not Ok"}$$

Select members passing the diameter to wall thickness ratio check may be considered in the design. The next step is to determine the compactness state for each member. There are three designations depending on the relationship of the diameter to wall thickness ratio compared with the limiting slenderness parameter for compact and noncompact sections.  $\lambda_p$  and  $\lambda_r$  in equations 12 and 13 represent the test parameters. Equation 14 is the test equations that categorizes the state of the section as either compact, noncompact, or slender.

$$\lambda_p = 0.07 * \frac{E}{F_y} \quad (12)$$

$$\lambda_r = 0.31 * \frac{E}{F_y} \quad (13)$$

$$\left(\frac{D}{t}\right)_{\text{actual}} \leq \lambda_p \text{ "Compact Section"} \quad (14)$$

$$\lambda_p < \left(\frac{D}{t}\right)_{\text{actual}} \leq \lambda_r \text{ "Noncompact Section"}$$

$$\left(\frac{D}{t}\right)_{\text{actual}} > \lambda_r \text{ "Slender Section"}$$

All members being considered for design were designated as compact due to the low  $\left(\frac{D}{t}\right)$  ratio.

Compact members do not have to be tested for local buckling, which means the plastic moment

strength ( $M_p$ ) can be calculated with equation 16 once the plastic section modulus ( $Z$ ) has been calculated using equation 15.

$$Z = \frac{D^3 - (OD - 2t)^3}{6} \quad (15)$$

$$M_p = F_y * Z \quad (16)$$

The variable  $OD$  is the outside diameter of the round HSS. The final step is to apply the LRFD factor of safety to obtain the final Design Flexural Strength ( $\phi M_n$ ) as shown in equation 9.

$$\phi M_n = 0.90 * M_p \quad (17)$$

### **Economic Analysis**

A brief economic analysis was completed that compared marginal benefit costs of varying design options with varying efficiency. Material prices were estimated and were consistent throughout the economic analysis. Member sizes can be adjusted depending on the load demand to achieve maximum economic effectiveness. The basic designs that were compared included an oversimplified version that only consisted of one type of structural member and another version that consisted of various types of structural members, which increased economic efficiency.

## **IV. Analysis and Results**

This chapter provides the results from the structural analysis of the modular overhead protection system. The primary method of research used was computer-based structural element analysis of multiple modular structures with the goal to identify the most critical members and obtain insight into how the structure behaves as the footprint changes. Once the critical loads were identified, the structural design of the members was accomplished according to governing UFCs and the AISC Manual standards. The results include compressive, shear, and flexural designs; it concludes with recommendations for two distinct designs (one based on constructability and one based on economic feasibility). Lastly, the results of the economic analysis between two designs is presented.

### **Results of Structural Analysis**

The following are the results of the structural analysis performed in STAAD<sup>®</sup>, which is a product of Bentley software. The design loads were outlined in Chapter III according to ASCE 7-10 and UFC standards. The original size of the design was created to provide overhead protection for one 8'x20' shipping container. Figure 2 shows the basic configuration of the structure. It was from this baseline configuration that design parameters were increased and decreased to find critical members experiencing the most stress. Table 5 provides a brief overview of the nine structural models that were created, analyzed, and designed. Various sizes of the modular facility had to be used to ensure that all possible loading conditions were captured and to understand the behavior of the structure as its footprint increased or decreased.

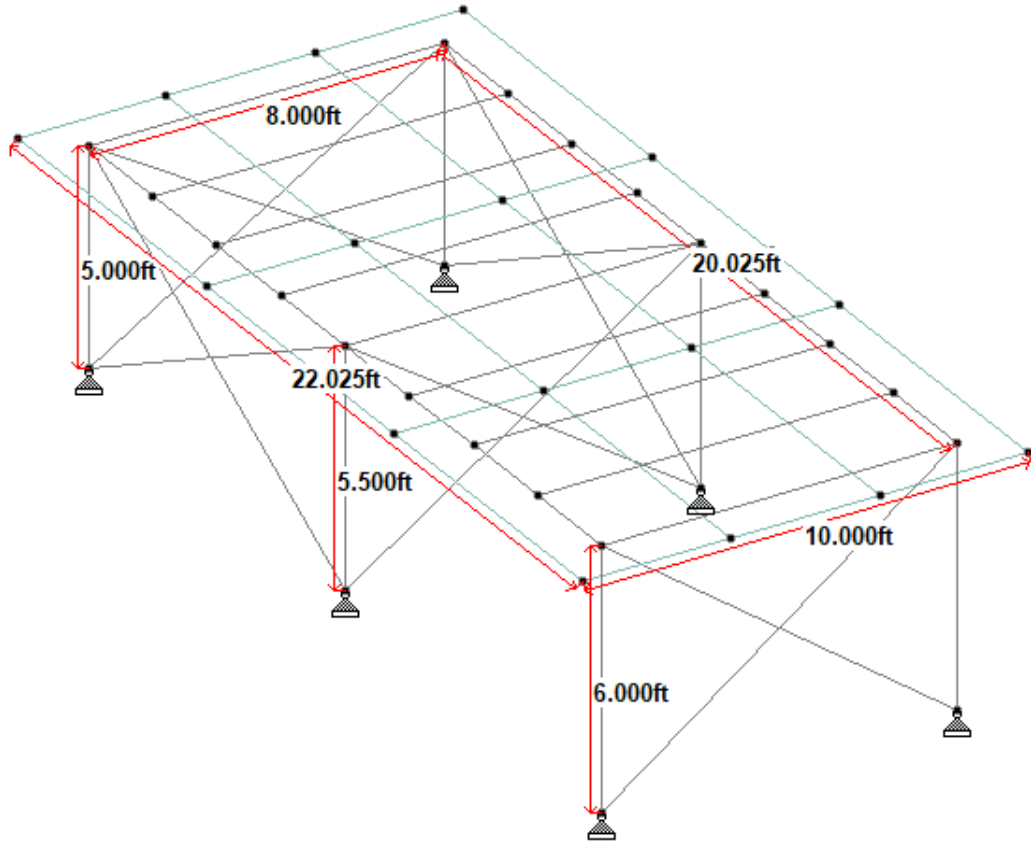

Figure 2. 8' x 20' Isometric View

Table 5. Model Numerical Descriptive Summary

Design #	Length (ft)	Width (ft)	Height (ft)	Area (SF)	Roof Slope
1	5	8	5.25	40	Mono
2	10	8	5.5	80	Mono
3	20	8	6	160	Mono
4	40	8	6	320	Gable
5	40	40	6	1,600	Gable
6	20	96	6	1,920	Mono
7	40	96	6	3,840	Gable
8	20	192	6	3,840	Mono
9	40	192	6	7,680	Gable

The height gradually changes along the length of the design to ensure that there is no pooling water on the roof system. Figure 3 shows the 1-foot slope over the span of 20 feet. Once the design expands past a length of 20 feet, the roofing system changes. This maintains a maximum height of 6 feet for the structure. It is important to note that this is only meant to reduce standing water and the expected life-cycle of the roofing system. The roof system is comprised of 8'x4'x $\frac{3}{4}$ " plywood attached to round HSS purlins by U-Hooks at 1-foot spacing. Metal decking secured on top of the plywood with self-adhesive screws to mitigate water seepage into the plywood. The roof consists of a 1-foot overhang on all outside edges of the overhead protection system.

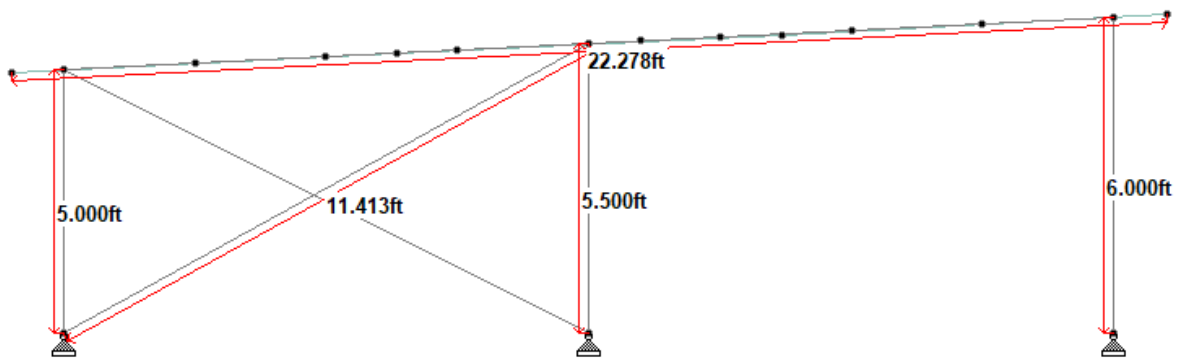

Figure 3. 8' x 20' Elevation View

The plan view, as seen in Figure 4, represents a bird's-eye view of the structure and shows the overhang of the roofing system from the structural support system. The roofing system was modeled in STAAD<sup>®</sup> using plate design. Since each panel of wood is not tied directly to any other panels, the roofing system was modeled as individual pieces; therefore, the

stresses experienced by each panel were minor and did not have an impact on the design of the structure.

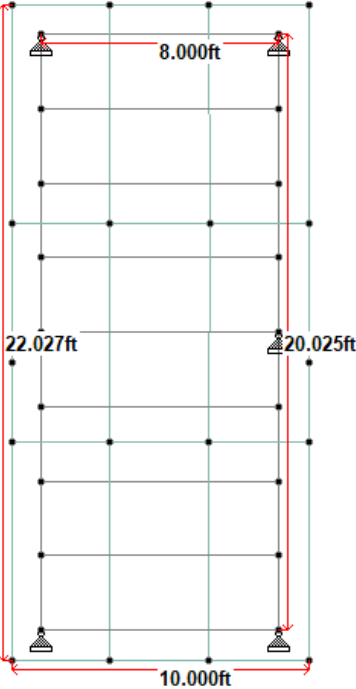

Figure 4. 8'x 20' Plan View

As discussed in Chapter III, the dead and live loads were applied to these structures. Figure 5 shows the manner in which vertical loads were applied to the system. The software models a pressure across the square footage of the roofing system to ensure that all weight is equally distributed across the entire structural frame. The loading types applied included dead, live, roof live, and snow loads.

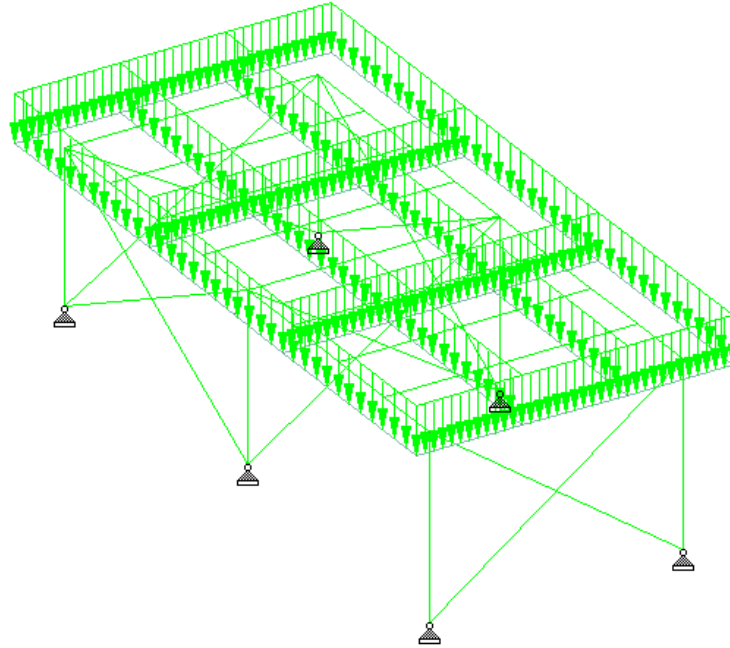

Figure 5. Vertical Loading Diagram

Wind loads were calculated using ASCE 7-10 standards with a base height of 30 feet. By beginning the height at this elevation, forces generated by the wind were significantly stronger than they would be at ground level. The reasoning for this base height is due to the uncertainty in regard to the location where this system may be installed and the height of the facility it is meant to be installed on. It is recommended that this design not be considered for overhead protection requirements for facilities greater than a height of 30 feet due to the positive relationship between wind strength and facility height. Figure 6 shows the modeled surface areas used in the software and how wind loads were applied to each structural support system. Parameters used to calculate wind loads were outlined in Chapter III. Wind loads did have a substantial effect and were included in the critical loading combination that controlled the

design. Please note that wind loads should be re-examined if base wind velocities are greater than what were used in the design.

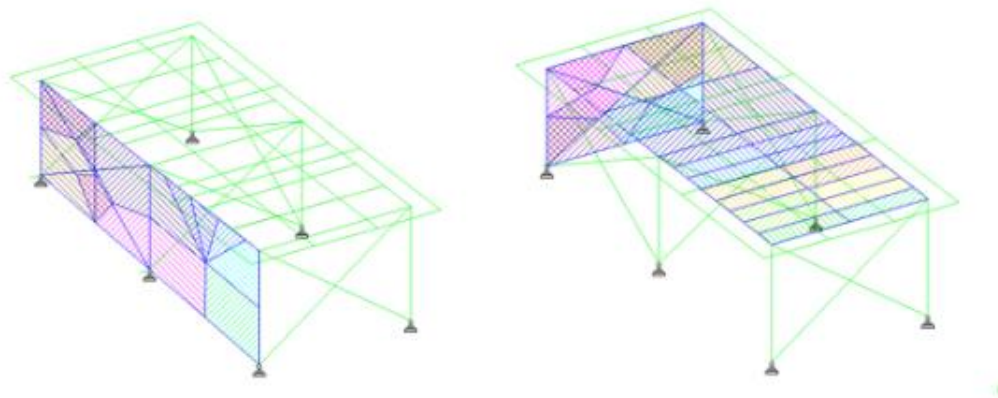

Figure 6. Wind Load (X-Z Direction)

Appendix A shows isometric, elevation, and plan views for the first five design variations. Only the first five variations are shown since the basic composition of the modular structure remains. As mentioned earlier, it is important to note that once the design length is greater than 20 feet, the roof system changes from a mono-sloped roof to a gable style roof. This currently gives a maximum length of 40 feet, but the potential width is unlimited. However, the length can be extended past 40 feet if additional modular structures are not connected to each other.

Once the geometric structure was created in STAAD<sup>®</sup>, the analysis was run on all nine variations. Each variation of the structure was tested against all loading combinations to calculate the most extreme axial, flexural, and shear loads that members would experience. The members that experienced the highest forces represent the loads that controlled the design of

members and the overall system. This also showed the overall behavior of the structure and that the greatest square footage did not correlate with the greatest load. This means that the shape of the modular structure may have a larger impact than the overall size. Further research is needed to thoroughly understand the relationship between member loading and the size and shape of members. Table and Table show the greatest positive and negative forces experienced by the members, which are annotated by asterisks. The critical member results occurred at the corner columns for the design, meaning that the most critical members experiencing the most load are in fact the columns, which is expected. A complete list of beam summary results can be seen in Appendix B.

Table 6. Beam Summary Results (+)

<b>Dimension</b>	<b>Design</b>	<b>SF</b>	<b>F<sub>x</sub> (lb)</b>	<b>F<sub>y</sub> (lb)</b>	<b>F<sub>z</sub> (lb)</b>	<b>M<sub>x</sub> (lb*ft)</b>	<b>M<sub>y</sub> (lb*ft)</b>	<b>M<sub>z</sub> (lb*ft)</b>
8x5	1	40	238.794	40.939	9.162	6	23	62
8x10	2	80	1,409.862	50.92	34.364	5	95*	95
8x20	3	160	441.693	94.184	62.33*	17	72	183
8x40	4	320	576.007	63.138	28.92	4	78	253*
40x40	5	1,600	2,837.90*	41.85	28.704	10	70	81
96x20	6	1,920	2,377.443	307.384	28.685	20*	63	85
96x40	7	3,840	2,739.144	41.88	28.703	3	80	81
192x20	8	3,840	2,389.096	309.319	28.684	20	63	88
192x40	9	7,680	2,786.697	309.41*	28.704	3	80	81

Table 7. Beam Summary Results (-)

<b>Dimension</b>	<b>Design</b>	<b>SF</b>	<b>Fx (lb)</b>	<b>Fy (lb)</b>	<b>Fz (lb)</b>	<b>Mx (lb*ft)</b>	<b>My (lb*ft)</b>	<b>Mz (lb*ft)</b>
8x5	1	40	-166.472	-36.61	-4.937	-3	-25	-51
8x10	2	80	-184.178	-47.274	-30.538	-9	-93*	-61
8x20	3	160	-353.681	-79.54*	-62.12*	-16	-92	-111*
8x40	4	320	-348.139	-63.138	-28.918	-8	-81	-58
40x40	5	1600	-158.563	-42.171	-25.909	-10	-80	-55
96x20	6	1920	-356.433	-53.196	-25.781	-12	-80	-55
96x40	7	3840	-176.712	-42.172	-28.675	-7	-80	-55
192x20	8	3840	-419.08*	-56.456	-25.781	-20*	-80	-55
192x40	9	7680	-208.23	-56.455	-28.702	-7	-80	-55

The reactionary forces shown in Table and Table 9 indicate that the final forces are distributed through the system to the existing structure and the asterisks note the maximum and minimum values experienced. There are no moments experienced throughout the structure due to the pinned connections that were used. Each individual design reaction calculation can be seen in Appendix C. For this research, the baseplates used ¾- inch bolts on all four sides of the baseplate. The baseplates are the greatest reinforcement possible and were designed based on the attachment of the structure to shipping containers; further research may be needed to determine compatibility of design with other roof types.

Table 8. Reactions Summary (+)

<b>Design</b>	<b>Dimensions</b>	<b>SF</b>	<b>Fx (lb)</b>	<b>Fy (lb)</b>	<b>Fz (lb)</b>
1	8x5	40	48.162	387.295	95.419
2	8x10	80	378.298	1877.337	296.258
3	8x20	160	101.374	704.368	130.729
4	8x40	320	85.571	771.848	120.09
5	40x40	1,600	687.439*	4093.49	542.993*
6	96x20	1,920	579.011	3,483.083	447.872
7	96x40	3,840	667.896	3,971.557	528.454
8	192x20	3,840	581.735	3,534.711	448.525
9	192x40	7,680	679.482	4,047.735*	538.772

Table 9. Reactions Summary (-)

<b>Design</b>	<b>Dimensions</b>	<b>SF</b>	<b>Fx (lb)</b>	<b>Fy (lb)</b>	<b>Fz (lb)</b>
1	8x5	40	-299.937	-242.847	-378.823
2	8x10	80	-460.44	-188.058	-529.126
3	8x20	160	-943.79	-334.245	-550.753
4	8x40	320	-1,102.494	-490.111*	-522.083
5	40x40	1,600	-1,227.55	-102.12	-942.946
6	96x20	1,920	-1,187.011*	-164.626	-1,599.71
7	96x40	3,840	-1,180.312	-113.823	-1,161.857
8	192x20	3,840	-1,172.727	-194.381	-1,666.238*
9	192x40	7,680	-1,164.085	-135.211	-1,193.46

## Results of Structural Design

For constructability purposes and use of scaffolding clamps, the only round HSS members considered for the design were diameters less than 2 inches but greater than 1 inch. This restriction was due to the capacity of clamp diameters. This resulted in four possible round HSS members, with each being tested for flexural, axial, and shear stress.

The calculated member flexural strength was greater than the required flexural strength demanded from the external loads, meaning that all members tested for design satisfy this requirement. A utilization rate represents the ratio of available strength compared to required strength. This ratio provides an explanation of whether a structural member is over or under designed. The highest utilization rate calculated was 0.24, which was for the smallest member tested. This means that only 24% of a member's strength is being used; therefore, there is a significant factor of safety built into the flexural strength for the members. The final calculations for flexural strength can be found in Appendix F.

The design shear strengths for all round HSS members were greater than the calculated required strengths. The results can be seen in Appendix E. This shows that the material strength for all members is more than adequate to handle the anticipated shear loads. This was expected as it was previously mentioned that shear strength rarely controls the design of members in a structure. The highest calculated utilization ratio was 0.285, which means that roughly 28% of the member's shear strength is used.

The final stress tested was the axial/compression stress. Only two members, HSS 1.9x0.188 and HSS 1.9x0.145, satisfied the compressive strength requirements; these members had a utilization ratio of 0.721 and 0.871, respectively. Therefore, the other possible members were eliminated from consideration for the design. However, these loads were for columns only.

The members eliminated due in fact satisfy all strength requirement for the girders, purlins, and cross bracing members. This means that a more economical design would consist of columns that are HSS 1.9x0.188 and all other structural members would be the smaller 1.66x0.140. The following section describes the economic analysis comparing the two designs.

### **Economic Analysis**

The cost of the system is relatively inexpensive compared to current means of overhead protection; however, it is still important to prioritize constructability versus economic feasibility. This estimate is independent from locational cost and escalation factors. However, the most beneficial aspect of this design comes from the truncated amount of materials used in the construction. The economic analysis and estimates for each structure are shown in Table 4. The cost estimates include a shielding layer comprised of a single layer of sandbags. The current design calls for HSS 1.9x0.188 for columns and girders and HSS 1.66x0.140 for cross bracing and purlins. However, after closer economic analysis, it is recommended that the structural tubing remain constant throughout the design due to the marginal economic benefits offered from switching from 1.9-inch to 1.66-inch round HSS members. Table 5 shows the comparison of results. The difference between the two designs ranges from \$2.26-\$1.28 per square foot. This amount may not seem significant, but it would drastically impact the amount of work during the construction process if multiple sized members were used. Design A (DA) is the more expensive but less complex design; while Design B (DB) represents the more cost efficient but more complex design. The recommendation of this research is that Design A be used since the most valuable asset in hostile fire locations is typically time and not money; however, depending on environmental constraints, decision-makers can use either of the two designs.

Table 4. 8x10 Cost/SF Estimate

<b>Material</b>	<b>Price/unit</b>	<b>Units</b>	<b>Estimate</b>
Scaffold Tube-Lock w/ End Fitting Base Plate	\$ 5.24	4	\$ 20.96
Duo Purpose Scaffold Clamp that Fits 1.6" - 2" Tubing	\$ 6.71	26	\$ 174.46
2" x 2" T-BOLT CLAMP - PSV-901T	\$ 8.89	4	\$ 35.56
HSS 1.9x0.188 (LF)	\$ 3.99	26	\$ 103.74
HSS 1.66x0.140 (LF)	\$ 2.62	132	\$ 345.84
36 in. W x 79 in. L Corrugated Roofing Sheets (SF)	\$ 20.00	80	\$ 81.01
Metal Roofing Screws - Pkg 250	\$ 23.43	1	\$ 23.43
3/4"x4x8 plywood (SF)	\$ 35.00	80	\$ 87.50
5/16'' x2'' x5'' Inch Zinc Square U Bolt with collar	\$ 2.46	40	\$ 98.40
Sandbags - 14" x 26" (SF)	\$ 0.40	80	\$ 12.70
<b>Total</b>			<b>\$ 983.60</b>
<b>\$/SF</b>			<b>\$ 12.30</b>

Table 5. Design Cost Analysis

<b>Layout</b>	<b>SF</b>	<b>Total Cost DA</b>	<b>Total Cost DB</b>	<b>\$/SF: DA</b>	<b>\$/SF: DB</b>	<b>Delta</b>
8x10	80	\$ 1,164.44	\$ 983.60	\$ 14.56	\$ 12.30	\$ 2.26
8x20	160	\$ 1,831.89	\$ 1,575.70	\$ 11.45	\$ 9.85	\$ 1.60
8x40	320	\$ 3,380.58	\$ 2,910.67	\$ 10.56	\$ 9.10	\$ 1.47
16x40	640	\$ 6,270.78	\$ 5,393.98	\$ 9.80	\$ 8.43	\$ 1.37
24x40	960	\$ 9,160.97	\$ 7,877.28	\$ 9.54	\$ 8.21	\$ 1.34
32x40	1280	\$ 12,051.17	\$ 10,360.59	\$ 9.41	\$ 8.09	\$ 1.32
40x40	1600	\$ 14,941.36	\$ 12,843.89	\$ 9.34	\$ 8.03	\$ 1.31
192x40	7680	\$ 69,714.47	\$ 59,886.09	\$ 9.08	\$ 7.80	\$ 1.28

## **V. Conclusion**

This chapter includes an overview of the findings and the potential conclusions drawn from them. The impact of the conclusions will also be discussed, along with the overall potential effect it can have on the use of modular pre-detonation screens on existing facilities. The final topic of discussion for the document will be possible future research to further develop the effectiveness of overhead protection for military forces inhabiting existing structures in hostile environments.

### **Findings Overview**

Through structural analysis and design, it was determined that HSS 1.9x0.188 members satisfied the critical loads imposed and could be used as the sole structural member throughout the design. This would simplify the overall design and ease construction and acquisition efforts. From a structural engineering standpoint, the most economical design is HSS 1.9x0.188 for all columns and girders, while using HSS 1.66x0.140 for all purlins and cross bracing members. This design reduces the overall complexity and costs of the structure but does increase complexity. Table 5 showed the marginal benefit of cost per square foot as the size of the structure increases. Although this price is independent from locational cost, escalation factors, and logistics costs, it provides a general idea of the relationship between cost per square foot and structure size. This research presents multiple options for design with the intent that design makers at the location may determine which one satisfies the constraints and goals of the objective. It is also worth noting that other avenues of overhead protection include MILCON or

the Modular Protection System. All are options, and depending on the situation, each present their own benefits.

### **Additional Research**

This research was preliminary and should be considered a “proof of concept” and not a ready-to-implement design in the field. Additional research should be done prior to full-scale testing. Structurally, further testing should be conducted on tube and clamp load capacity; since the design is not a pre-fabricated design from a supplier, the joint connections may not perform as advertised by manufacturers. It is recommended that analysis be conducted specifically with conventional or empirical load bearing tests to ensure that loads listed in Appendix B are capable of being handled by clamps in an inventory list.

Additionally, base supports should be further researched since existing facility roofs may limit types of acceptable connections. This research assumed the base for the structure to be shipping containers. Further research should determine other roof types to which this structure could be attached and the design for such a connection.

Further research on the limitations of the facilities to which this type of system can be attached is crucial since this design relies on the support of the existing facility. Shipping containers are able to support the load of the pre-detonation and shielding layer, but other facilities may not be able to support such a load depending on the type of construction, materials used, and overall structural design. For existing facilities that cannot support additional weight from the system, other avenues should be explored such as MILCON and MPS.

Comparison of this research design with existing designs, such as MILCON and MPS, should be done with further research to appropriately determine the strengths and weaknesses of the systems and give decision-makers a complete picture of which system should be used given certain situations. The research should revolve around expert opinion, commander inputs, and the physical constraints of each system being considered. This decision matrix should aim to create a system of systems in which the overall goal is providing overhead protection to existing facilities.

The final area of research that should be done is a blast analysis on the designed structure. The intent of blast analysis is to ensure that the failure of the structure after impact does not cause undue damage to the existing structure. The blast may be simulated with a single point load on the structural system to determine if progressive failure throughout the structure would occur.

# Appendix A

## Design Isometric and Elevation Views

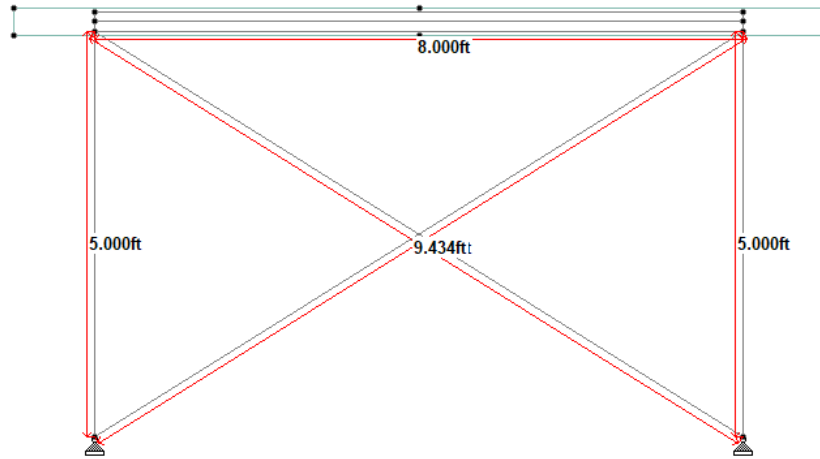

Figure 7. 8' x 5' Elevation View

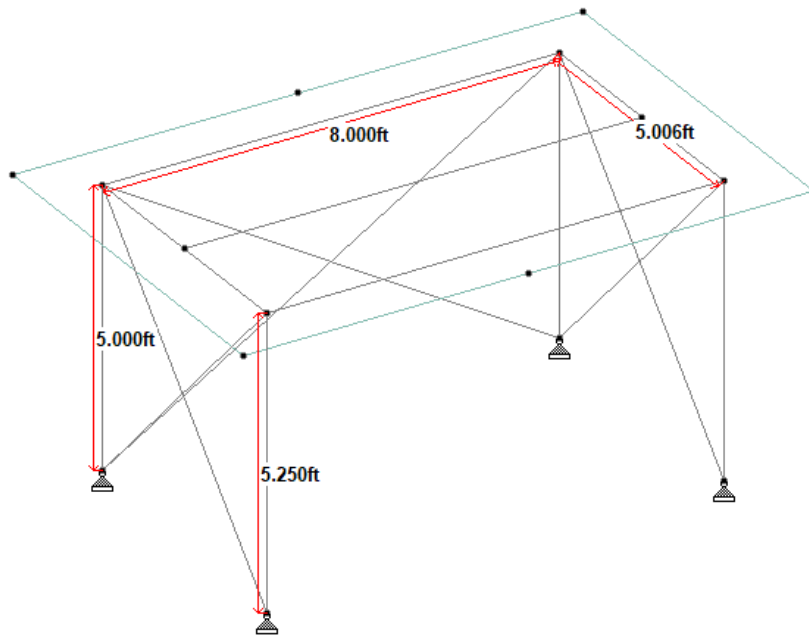

Figure 8. 8' x 5' Isometric View

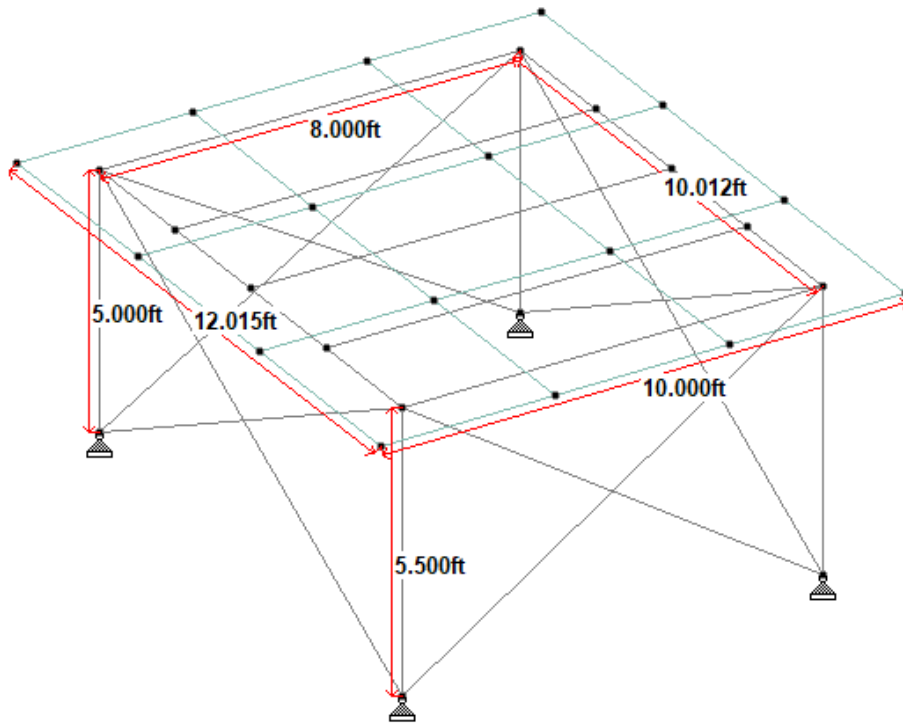

Figure 9. 8' x 10' Isometric View

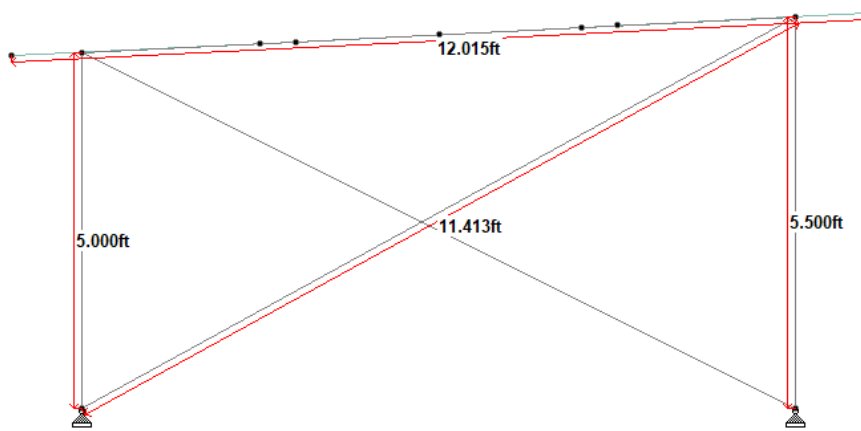

Figure 10. 8' x 10' Elevation View

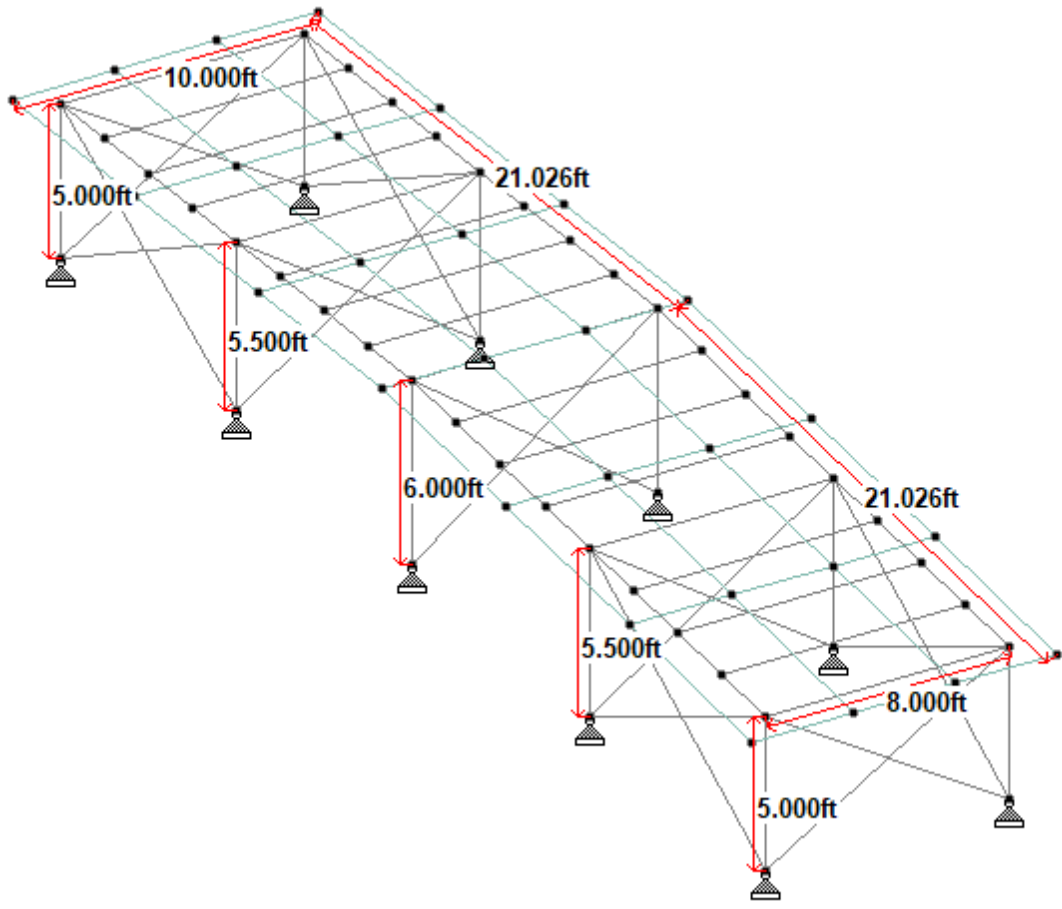

Figure 11. 8' x 40' Isometric View

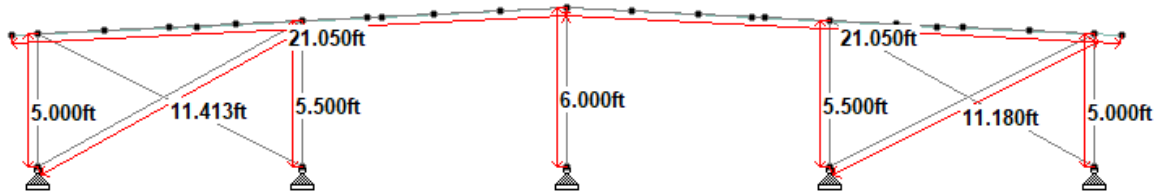

Figure 12. 8' x 40' Elevation View

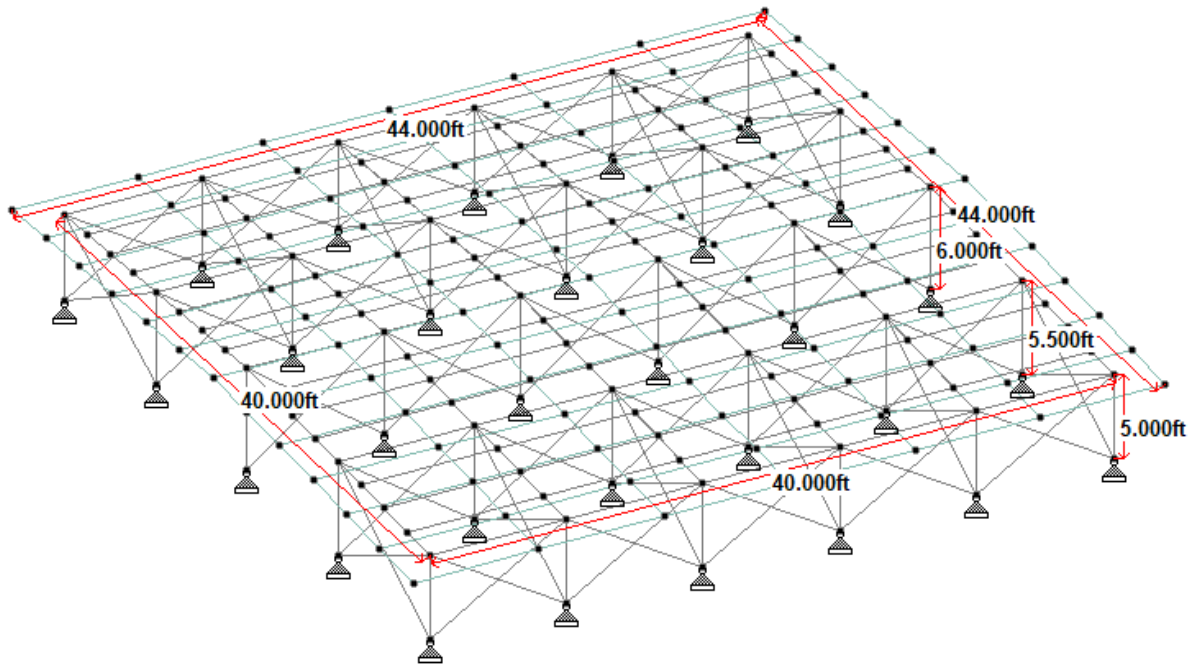

Figure 13. 40' x 40' Isometric View

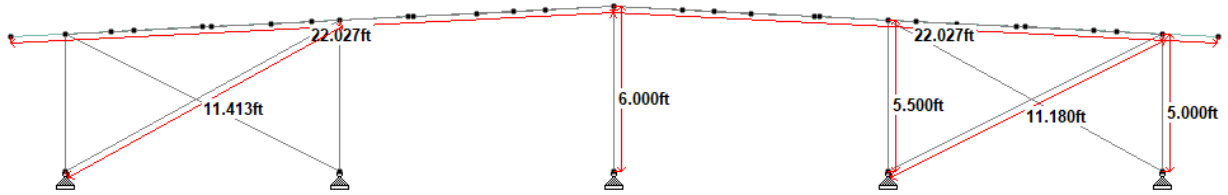

Figure 14. 40' x 40' Elevation View

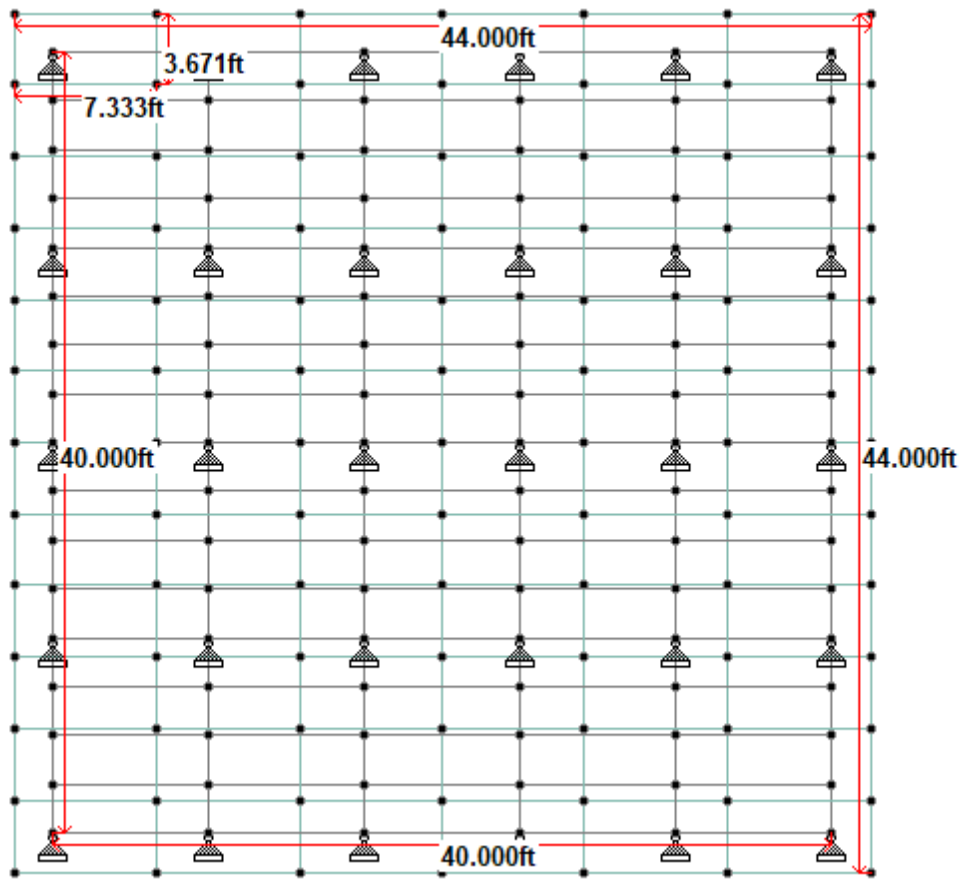

Figure 15. 40' x 40' Plan View

## Appendix B

### Beam Summary Results

Table 6. 8 x 5 Beam Summary

	Beam #	Load Condition	Fx (lb)	Fy (lb)	Fz (lb)	Mx (lb')	My (lb')	Mz (lb')
Max Fx	60	10 1.2D+1.0WZ+L+0.5LR	<b>238.794</b>	-17.369	-1.617	3	0	17
Min Fx	61	4 WLZ	<b>-166.472</b>	0.075	-0.018	0	0	0
Max Fy	4	5 1.4D	0	<b>40.939</b>	-0.043	-2	0	61
Min Fy	37	5 1.4D	61.46	<b>-36.61</b>	2.206	-1	12	49
Max Fz	56	5 1.4D	73.376	5.568	<b>9.162</b>	-3	-25	26
Min Fz	26	5 1.4D	92.493	-10.623	<b>-4.937</b>	-2	8	-18
Max Mx	54	5 1.4D	1.127	27.803	2.395	<b>6</b>	-4	28
Min Mx	56	5 1.4D	73.376	5.568	9.162	<b>-3</b>	-25	26
Max My	31	5 1.4D	94.838	18.021	8.81	2	<b>23</b>	-51
Min My	56	5 1.4D	73.376	5.568	9.162	-3	<b>-25</b>	26
Max Mz	36	5 1.4D	3.829	37.653	-1.29	-1	4	<b>62</b>
Min Mz	31	5 1.4D	94.838	18.021	8.81	2	23	<b>-51</b>

Table 7. 8 x 10 Beam Summary

	Beam #	Load Condition	Fx (lb)	Fy (lb)	Fz (lb)	Mx (lb')	My (lb')	Mz (lb')
Max Fx	31	7 1.2D + 1.6LR +0.5WX	<b>1409.862</b>	14.948	25.806	0	-58	33
Min Fx	40	3 WLX	<b>-184.178</b>	-0.083	0.011	0	0	0
Max Fy	43	5 1.4D	2.255	<b>50.92</b>	-0.324	5	1	95
Min Fy	35	5 1.4D	184.778	<b>-47.274</b>	-2.907	1	-16	83
Max Fz	31	5 1.4D	797.196	19.716	<b>34.364</b>	-1	-77	44
Min Fz	30	5 1.4D	788.968	20.202	<b>-30.538</b>	2	75	51
Max Mx	43	5 1.4D	2.255	50.92	-0.324	<b>5</b>	1	95
Min Mx	4	5 1.4D	0	41.303	-0.843	<b>-9</b>	2	62
Max My	31	5 1.4D	752.097	19.716	34.364	-1	<b>95</b>	-55
Min My	30	5 1.4D	739.359	20.202	-30.538	2	<b>-93</b>	-61
Max Mz	43	5 1.4D	2.255	50.92	-0.324	5	1	<b>95</b>
Min Mz	30	5 1.4D	739.359	20.202	-30.538	2	-93	<b>-61</b>

Table 8. 8 x 20 Beam Summary

	Beam #	Load Condition	Fx (lb)	Fy (lb)	Fz (lb)	Mx (lb')	My (lb')	Mz (lb')
Max Fx	41	9 1.2D+1.0WX+L+0.5LR	<b>441.693</b>	-29.093	-0.763	5	5	45
Min Fx	40	3 WLX	<b>-353.681</b>	-0.18	-2.333	-2	7	-1
Max Fy	48	5 1.4D	22.944	<b>94.184</b>	-0.709	-16	2	183
Min Fy	55	5 1.4D	14.202	<b>-79.548</b>	-4.466	-14	-8	109
Max Fz	46	9 1.2D+1.0WX+L+0.5LR	36.246	80.249	<b>62.336</b>	15	-92	156
Min Fz	55	9 1.2D+1.0WX+L+0.5LR	30.121	-52.018	<b>-62.122</b>	-13	72	-53
Max Mx	46	5 1.4D	22.829	93.971	0.851	<b>17</b>	-2	181
Min Mx	48	5 1.4D	22.944	94.184	-0.709	<b>-16</b>	2	183
Max My	55	9 1.2D+1.0WX+L+0.5LR	30.121	-52.018	-62.122	-13	<b>72</b>	-53
Min My	46	9 1.2D+1.0WX+L+0.5LR	36.246	80.249	62.336	15	<b>-92</b>	156
Max Mz	48	5 1.4D	22.944	94.184	-0.709	-16	2	<b>183</b>
Min Mz	51	5 1.4D	17.716	-8.555	0.216	-3	0	<b>-111</b>

Table 9. 8x40 Beam Summary

	Beam #	Load Condition	Fx (lb)	Fy (lb)	Fz (lb)	Mx (lb')	My (lb')	Mz (lb')
Max Fx	86	9 1.2D+1.0WX+L+0.5LR	<b>576.007</b>	-28.57	-2.711	-1	-14	43
Min Fx	85	3 WLX	<b>-348.139</b>	-0.219	0.029	0	0	-1
Max Fy	57	5 1.4D	0	<b>63.138</b>	0	0	0	253
Min Fy	58	5 1.4D	0	<b>-63.138</b>	0	0	0	253
Max Fz	75	5 1.4D	113.034	-19.806	<b>28.92</b>	-2	-81	-54
Min Fz	78	5 1.4D	152.513	19.806	<b>-28.918</b>	2	63	45
Max Mx	43	5 1.4D	1.973	41.441	-0.023	<b>4</b>	0	72
Min Mx	4	5 1.4D	0	36.214	-0.646	<b>-8</b>	2	54
Max My	31	5 1.4D	151.449	17.372	27.809	0	<b>78</b>	-49
Min My	75	5 1.4D	113.034	-19.806	28.92	-2	<b>-81</b>	-54
Max Mz	57	5 1.4D	0	63.138	0	0	0	<b>253</b>
Min Mz	45	5 1.4D	116.448	17.913	-0.013	0	0	<b>-58</b>

Table 10. 40 x 40 Beam Summary

	Beam #	Load Condition	Fx (lb)	Fy (lb)	Fz (lb)	Mx (lb')	My (lb')	Mz (lb')
Max Fx	151	7 1.2D + 1.6Lr + 0.5Wx	<b>2837.908</b>	15.414	16.043	-1	-45	35
Min Fx	281	4 WLZ	<b>-158.563</b>	0.071	-0.008	0	0	0
Max Fy	164	5 1.4D	-1.973	<b>41.85</b>	-0.037	0	0	67
Min Fy	160	5 1.4D	-1.973	<b>-42.171</b>	0.006	0	1	68
Max Fz	172	5 1.4D	1340.361	-16.597	<b>28.704</b>	-2	-80	-45
Min Fz	175	5 1.4D	1384.44	2.286	<b>-25.909</b>	0	57	5
Max Mx	132	5 1.4D	-0.493	10.09	2.091	<b>10</b>	-4	4
Min Mx	261	5 1.4D	-0.493	10.091	-2.092	<b>-10</b>	4	4
Max My	31	5 1.4D	1345.392	0.711	25.17	1	<b>70</b>	-2
Min My	172	5 1.4D	1340.361	-16.597	28.704	-2	<b>-80</b>	-45
Max Mz	33	5 1.4D	251.513	41.677	1.155	1	-4	<b>81</b>
Min Mz	51	5 1.4D	0.493	19.895	0.405	2	1	<b>-55</b>

Table 11. 96x20 Beam Summary

	Beam #	Load Condition	Fx (lb)	Fy (lb)	Fz (lb)	Mx (lb')	My (lb')	Mz (lb')
Max Fx	172	8 1.2D + 1.6LR + 0.5WZ	<b>2377.443</b>	-14.288	24.865	-2	55	33
Min Fx	665	4 WLZ	<b>-356.433</b>	0.187	-0.011	0	0	1
Max Fy	1513	5 1.4D	0	<b>307.384</b>	1.206	0	0	29
Min Fy	1601	5 1.4D	0	<b>-53.196</b>	-1.064	0	0	23
Max Fz	172	5 1.4D	1146.353	-16.564	<b>28.685</b>	-2	-80	-45
Min Fz	175	5 1.4D	1180.441	2.279	<b>-25.781</b>	0	57	5
Max Mx	1607	5 1.4D	0	-33.06	1.977	<b>20</b>	0	-5
Min Mx	700	5 1.4D	0	6.015	-0.497	<b>-12</b>	0	7
Max My	172	5 1.4D	1185.814	-16.564	28.685	-2	<b>63</b>	38
Min My	172	5 1.4D	1146.353	-16.564	28.685	-2	<b>-80</b>	-45
Max Mz	161	5 1.4D	1.973	-43.322	0.012	-1	0	<b>85</b>
Min Mz	192	5 1.4D	0.493	20.847	-0.051	-2	0	<b>-55</b>

Table 12. 96x40 Beam Summary

	Beam #	Load Condition	Fx (lb)	Fy (lb)	Fz (lb)	Mx (lb')	My (lb')	Mz (lb')
Max Fx	172	8 1.2D + 1.6LR + 0.5WZ	<b>2739.144</b>	-14.327	24.776	-2	55	33
Min Fx	177	4 WLZ	<b>-176.712</b>	0.091	0.006	0	0	0
Max Fy	648	5 1.4D	-1.973	<b>41.88</b>	-0.025	0	0	67
Min Fy	160	5 1.4D	-1.973	<b>-42.172</b>	0.002	0	0	68
Max Fz	172	5 1.4D	1330.356	-16.599	<b>28.703</b>	-2	-80	-45
Min Fz	655	5 1.4D	1309.904	16.592	<b>-28.675</b>	-2	80	45
Max Mx	1	5 1.4D	1.973	41.375	-0.04	<b>3</b>	0	72
Min Mx	4	5 1.4D	0	31.854	-0.068	<b>-7</b>	0	43
Max My	655	5 1.4D	1309.904	16.592	-28.675	-2	<b>80</b>	45
Min My	172	5 1.4D	1330.356	-16.599	28.703	-2	<b>-80</b>	-45
Max Mz	33	5 1.4D	249.622	41.679	1.153	1	-4	<b>81</b>
Min Mz	51	5 1.4D	0.493	21.049	0.271	3	1	<b>-55</b>

Table 19. 192x20 Beam Summary

	Beam #	Load Condition	Fx (lb)	Fy (lb)	Fz (lb)	Mx (lb')	My (lb')	Mz (lb')
Max Fx	172	8 1.2D + 1.6LR + 0.5WZ	<b>2389.096</b>	-14.288	24.926	-2	55	33
Min Fx	1051	4 WLZ	<b>-419.08</b>	0.217	-0.015	0	0	1
Max Fy	1707	5 1.4D	0	<b>309.319</b>	-0.902	0	0	29
Min Fy	1619	5 1.4D	0	<b>-56.456</b>	0.045	0	0	23
Max Fz	172	5 1.4D	1146.737	-16.565	<b>28.684</b>	-2	-80	-45
Min Fz	175	5 1.4D	1186.193	2.277	<b>-25.781</b>	0	57	5
Max Mx	1607	5 1.4D	0	-44.461	3.161	<b>20</b>	0	-6
Min Mx	1625	5 1.4D	0	-44.508	-3.163	<b>-20</b>	0	-6
Max My	172	5 1.4D	1186.198	-16.565	28.684	-2	<b>63</b>	38
Min My	172	5 1.4D	1146.737	-16.565	28.684	-2	<b>-80</b>	-45
Max Mz	1037	5 1.4D	1.973	44.33	-0.402	0	2	<b>88</b>
Min Mz	192	5 1.4D	0.493	20.845	-0.051	-2	0	<b>-55</b>

Table 13. 192x40 Beam Summary

	Beam #	Load Condition	Fx (lb)	Fy (lb)	Fz (lb)	Mx (lb')	My (lb')	Mz (lb')
Max Fx	172	8 1.2D + 1.6LR + 0.5WZ	<b>2786.697</b>	-14.33	24.801	-2	55	`
Min Fx	1051	4 WLZ	<b>-208.23</b>	0.107	-0.007	0	0	1
Max Fy	1725	5 1.4D	0	<b>309.412</b>	1.257	0	0	29
Min Fy	1802	5 1.4D	0	<b>-56.455</b>	-0.042	0	0	23
Max Fz	172	5 1.4D	1346.84	-16.598	<b>28.704</b>	-2	-80	-45
Min Fz	900	5 1.4D	1346.688	16.598	<b>-28.702</b>	-2	80	45
Max Mx	1	5 1.4D	1.973	41.375	-0.041	<b>3</b>	0	72
Min Mx	4	5 1.4D	0	31.854	-0.068	<b>-7</b>	0	43
Max My	900	5 1.4D	1346.688	16.598	-28.702	-2	<b>80</b>	45
Min My	172	5 1.4D	1346.84	-16.598	28.704	-2	<b>-80</b>	-45
Max Mz	33	5 1.4D	253.101	41.677	1.154	1	-4	<b>81</b>
Min Mz	51	5 1.4D	0.493	21.002	0.358	2	1	<b>-55</b>

## Appendix C

### Reaction Summary Results

Table 14. 8x5 Reaction Summary

	Node	Load Condition	Fx (lb)	Fy (lb)	Fz (lb)
Max Fx	19	5 1.4D	<b>48.162</b>	275.435	46.398
Min Fx	19	3 WLX	<b>-299.937</b>	-185.622	-60.62
Max Fy	45	10 1.2D+1.0WZ+L+0.5LR	-5.799	<b>387.295</b>	-378.823
Min Fy	20	4 WLZ	25.354	<b>-242.847</b>	-114.979
Max Fz	20	9 1.2D+1.0WX+L+0.5LR	-172.845	386.257	<b>95.419</b>
Min Fz	45	10 1.2D+1.0WZ+L+0.5LR	-5.799	387.295	<b>-378.823</b>
Max Mx	19	1 DL	30.101	172.147	28.999
Min Mx	19	1 DL	30.101	172.147	28.999
Max My	19	1 DL	30.101	172.147	28.999
Min My	19	1 DL	30.101	172.147	28.999
Max Mz	19	1 DL	30.101	172.147	28.999
Min Mz	19	1 DL	30.101	172.147	28.999

Table 15. 8x10 Reaction Table

	Node	Load Condition	Fx (lb)	Fy (lb)	Fz (lb)
Max Fx	23	8 1.2D + 1.6LR +0.5WZ	<b>378.298</b>	1838.3	-329.423
Min Fx	19	3 WLX	<b>-460.44</b>	-187.423	-27.64
Max Fy	24	7 1.2D + 1.6LR +0.5WX	-440.928	<b>1877.337</b>	-281.467
Min Fy	23	3 WLX	-285.995	<b>-188.058</b>	4.307
Max Fz	20	7 1.2D + 1.6LR +0.5WX	-402.454	1870.543	<b>296.258</b>
Min Fz	19	4 WLZ	-20.431	-112.462	<b>-529.126</b>
Max Mx	19	1 DL	125.874	680.733	107.593
Min Mx	19	1 DL	125.874	680.733	107.593
Max My	19	1 DL	125.874	680.733	107.593
Min My	19	1 DL	125.874	680.733	107.593
Max Mz	19	1 DL	125.874	680.733	107.593
Min Mz	19	1 DL	125.874	680.733	107.593

Table 16. 8x20 Reaction Summary

	<b>Node</b>	<b>Load Condition</b>	<b>Fx (lb)</b>	<b>Fy (lb)</b>	<b>Fz (lb)</b>
Max Fx	23	10 1.2D+1.0WZ+L+0.5LR	<b>101.374</b>	504.325	-167.619
Min Fx	23	3 WLX	<b>-943.79</b>	-334.245	-17.89
Max Fy	24	9 1.2D+1.0WX+L+0.5LR	-366.631	<b>704.368</b>	-24.232
Min Fy	23	3 WLX	-943.79	<b>-334.245</b>	-17.89
Max Fz	20	9 1.2D+1.0WX+L+0.5LR	-245.663	585.641	<b>130.729</b>
Min Fz	19	4 WLZ	-23.012	-136.918	<b>-550.753</b>
Max Mx	19	1 DL	39.109	224.21	44.044
Min Mx	19	1 DL	39.109	224.21	44.044
Max My	19	1 DL	39.109	224.21	44.044
Min My	19	1 DL	39.109	224.21	44.044
Max Mz	19	1 DL	39.109	224.21	44.044
Min Mz	19	1 DL	39.109	224.21	44.044

Table 17. 8x40 Reaction table

	<b>Node</b>	<b>Load Condition</b>	<b>Fx (lb)</b>	<b>Fy (lb)</b>	<b>Fz (lb)</b>
Max Fx	23	10 1.2D+1.0WZ+L+0.5LR	<b>85.571</b>	424.72	-143.754
Min Fx	76	3 WLX	<b>-1102.49</b>	-490.111	-27.891
Max Fy	77	9 1.2D+1.0WX+L+0.5LR	-476.322	<b>771.848</b>	66.129
Min Fy	76	3 WLX	-1102.49	<b>-490.111</b>	-27.891
Max Fz	20	9 1.2D+1.0WX+L+0.5LR	-244.465	575.894	<b>120.09</b>
Min Fz	19	4 WLZ	-18.728	-103.808	<b>-522.083</b>
Max Mx	19	1 DL	39.628	227.46	41.547
Min Mx	19	1 DL	39.628	227.46	41.547
Max My	19	1 DL	39.628	227.46	41.547
Min My	19	1 DL	39.628	227.46	41.547
Max Mz	19	1 DL	39.628	227.46	41.547
Min Mz	19	1 DL	39.628	227.46	41.547

Table 18. 40x40 Reaction Summary

	<b>Node</b>	<b>Load Condition</b>	<b>Fx (lb)</b>	<b>Fy (lb)</b>	<b>Fz (lb)</b>
Max Fx	91	8 1.2D + 1.6Lr + 0.5Wz	<b>687.439</b>	3304.417	449.425
Min Fx	91	3 WLX	<b>-1227.55</b>	-86.062	-7.478
Max Fy	122	8 1.2D + 1.6Lr + 0.5Wz	6.257	<b>4093.49</b>	-608.889
Min Fy	60	4 WLZ	-6.413	<b>-102.12</b>	-744.585
Max Fz	60	7 1.2D + 1.6Lr + 0.5Wx	-72.343	4056.617	<b>542.993</b>
Min Fz	20	4 WLZ	-6.412	-100.256	<b>-942.946</b>
Max Mx	19	1 DL	240.773	1286.815	194.315
Min Mx	19	1 DL	240.773	1286.815	194.315
Max My	19	1 DL	240.773	1286.815	194.315
Min My	19	1 DL	240.773	1286.815	194.315
Max Mz	19	1 DL	240.773	1286.815	194.315
Min Mz	19	1 DL	240.773	1286.815	194.315

Table 19. 92x20 Reaction Summary

	<b>Node</b>	<b>Load Condition</b>	<b>Fx (lb)</b>	<b>Fy (lb)</b>	<b>Fz (lb)</b>
Max Fx	91	8 1.2D + 1.6LR + 0.5WZ	<b>579.011</b>	2756.995	301.135
Min Fx	91	3 WLX	<b>-1187.01</b>	-24.203	0.771
Max Fy	90	8 1.2D + 1.6LR + 0.5WZ	-0.995	<b>3483.083</b>	-899.482
Min Fy	379	4 WLZ	1	<b>-164.626</b>	-319.435
Max Fz	91	7 1.2D + 1.6LR + 0.5WX	-13.856	2820.563	<b>447.872</b>
Min Fz	302	10 1.2D + 1.0WZ + L + .5LR	3.762	2249.081	<b>-1599.71</b>
Max Mx	21	1 DL	211.903	909.161	0.661
Min Mx	21	1 DL	211.903	909.161	0.661
Max My	21	1 DL	211.903	909.161	0.661
Min My	21	1 DL	211.903	909.161	0.661
Max Mz	21	1 DL	211.903	909.161	0.661
Min Mz	21	1 DL	211.903	909.161	0.661

Table 20. 92x40 Reaction Summary

	<b>Node</b>	<b>Load Condition</b>	<b>Fx (lb)</b>	<b>Fy (lb)</b>	<b>Fz (lb)</b>
Max Fx	91	8 1.2D + 1.6LR + 0.5WZ	<b>667.896</b>	3211.482	424.861
Min Fx	91	3 WLX	<b>-1180.31</b>	-28.994	-2.191
Max Fy	90	8 1.2D + 1.6LR + 0.5WZ	-2.346	<b>3971.557</b>	-605.977
Min Fy	20	4 WLZ	2.489	<b>-113.823</b>	-962.882
Max Fz	345	7 1.2D + 1.6LR + 0.5WX	-31.624	3898.693	<b>528.454</b>
Min Fz	244	4 WLZ	2.488	-111.654	<b>-1161.86</b>
Max Mx	19	1 DL	238.329	1277.183	192.876
Min Mx	19	1 DL	238.329	1277.183	192.876
Max My	19	1 DL	238.329	1277.183	192.876
Min My	19	1 DL	238.329	1277.183	192.876
Max Mz	19	1 DL	238.329	1277.183	192.876
Min Mz	19	1 DL	238.329	1277.183	192.876

Table 21. 192x20 Reaction Summary

	<b>Node</b>	<b>Load Condition</b>	<b>Fx (lb)</b>	<b>Fy (lb)</b>	<b>Fz (lb)</b>
Max Fx	89	8 1.2D + 1.6LR + 0.5WZ	<b>581.735</b>	3143.229	-832.973
Min Fx	91	3 WLX	<b>-1172.73</b>	-10.733	0.297
Max Fy	652	8 1.2D + 1.6LR + 0.5WZ	1.837	<b>3534.711</b>	-941.055
Min Fy	654	4 WLZ	-0.07	<b>-194.381</b>	-375.067
Max Fz	91	7 1.2D + 1.6LR + 0.5WX	-4.861	2831.175	<b>448.525</b>
Min Fz	771	10 1.2D + 1.0WZ + L + .5LR	1.398	2388.942	<b>-1666.24</b>
Max Mx	21	1 DL	211.961	908.008	0.661
Min Mx	21	1 DL	211.961	908.008	0.661
Max My	21	1 DL	211.961	908.008	0.661
Min My	21	1 DL	211.961	908.008	0.661
Max Mz	21	1 DL	211.961	908.008	0.661
Min Mz	21	1 DL	211.961	908.008	0.661

Table 29. 192x40 Reaction Summary

	<b>Node</b>	<b>Load Condition</b>	<b>Fx (lb)</b>	<b>Fy (lb)</b>	<b>Fz (lb)</b>
Max Fx	91	8 1.2D + 1.6LR + 0.5WZ	<b>679.482</b>	3258.926	419.419
Min Fx	91	3 WLX	<b>-1164.09</b>	-12.647	-0.7
Max Fy	652	8 1.2D + 1.6LR + 0.5WZ	1.412	<b>4047.735</b>	-629.227
Min Fy	582	4 WLZ	-0.322	<b>-135.211</b>	-789.213
Max Fz	713	7 1.2D + 1.6LR + 0.5WX	-16.302	3978.585	<b>538.772</b>
Min Fz	713	4 WLZ	-0.324	-134.929	<b>-1193.46</b>
Max Mx	19	1 DL	241.317	1291.889	194.925
Min Mx	19	1 DL	241.317	1291.889	194.925
Max My	19	1 DL	241.317	1291.889	194.925
Min My	19	1 DL	241.317	1291.889	194.925
Max Mz	19	1 DL	241.317	1291.889	194.925
Min Mz	19	1 DL	241.317	1291.889	194.925

## Appendix D

### Flexural Buckling Compressive Strength

Table 22. Flexural Buckling Compressive Strength

<b>Dimensions and Properties</b>	<b>Variable</b>	<b>HSS 1.9x0.188</b>	<b>HSS 1.9x0.145</b>	<b>HSS 1.9x 0.120</b>	<b>HSS 1.66x0.140</b>
Gross Cross-sectional Area	Ag	0.943	0.749	0.624	0.625
Modulus of Elasticity (KSI)	E	29000	29000	29000	29000
Yield Strength (ASTM A500)	Fy	46	46	46	46
<b>Slenderness Ratio</b>					
Effective length (ft)	K	6	6	6	6
Unbraced length (ft)	L	6	6	6	6
Radius of Gyration in	r	0.613	0.626	0.634	0.543
Critical Stress Equations		118.261	118.261	118.261	118.261
<b>Critical Stress</b>					
Slenderness Ratio	(KL/r)	704.731	690.096	681.388	795.580
Elastic Buckling Stress	Fe	0.576	0.601	0.616	0.452
Critical Stress	Fcr	0.505	0.527	0.541	0.397
<b>Strength Calculations</b>					
Nominal Strength	Pn	0.477	0.395	0.337	0.248
Design Strength ( $\phi=0.9$ )	$\phi Pn$	0.429	0.355	0.304	0.223
Required Strength	Pu	0.309	0.309	0.309	0.309
Utilization Ratio	UR	<b>0.721</b>	<b>0.871</b>	1.019	1.387
Pass/Fail		<b>Pass</b>	<b>Pass</b>	<b>Fail</b>	<b>Fail</b>

## Appendix E

### Design Shear Strength Calculation

Table 23. Shear Strength Calculations

<b>Dimensions and Properties</b>	<b>Variable</b>	<b>HSS 1.9x0.188</b>	<b>HSS 1.9x0.145</b>	<b>HSS 1.9x .120</b>	<b>HSS 1.66x0.140</b>
Cross-sectional Area	$A_g$ ( $in^2$ )	0.943	0.749	0.624	0.625
Modulus of Elasticity	E(KSI)	29000	29000	29000	29000
Yield Strength	$F_y$ (KSI)	46	46	46	46
Radius	R (in)	0.613	0.626	0.634	0.543
Thickness	T (in)	0.174	0.135	0.111	0.13
<b>Design Calculation</b>					
Nominal Strength	$V_n$	16.975609	16.5821094	16.3653846	19.136
Design Strength ( $\phi=0.6$ )	$\phi V_n$	10.185365	9.94926568	9.81923076	11.4816
Required Strength	$V_u$ (kips)	<b>2.837</b>	<b>2.837</b>	<b>2.837</b>	<b>2.837</b>
Utilization Ratio	UR	<b>0.2785368</b>	<b>0.28514667</b>	<b>0.28892283</b>	<b>0.24709099</b>

## Appendix F

### Design Flexural Strength Calculation

Table 24. Design Flexural Strength

<b>Dimensions and Properties</b>	<b>Variable</b>	<b>HSS 1.9x0.188</b>	<b>HSS 1.9x0.145</b>	<b>HSS 1.9x .120</b>	<b>HSS 1.66x0.140</b>
Design Wall Thickness	T (in)	0.174	0.135	0.111	0.13
Outside Diameter	D (in)	1.9	1.9	1.9	1.66
Modulus of Elasticity	E (KSI)	29000	29000	29000	29000
Yield Strength	Fy (KSI)	46	46	46	46
<b>Section Properties</b>					
Diameter to Wall Thickness	D/t	10.920	14.074	17.117	12.769
Inside diameter	ID (in)	1.552	1.63	1.678	1.4
Elastic Section Modulus	S ( <i>in</i> <sup>3</sup> )	3.907	4.753	5.339	1.725
Plastic Section Modulus	Z ( <i>in</i> <sup>3</sup> )	0.520	0.421	0.356	0.305
<b>D/t Ratio check</b>					
Limiting D/t Ratio	(D/t)	283.696	283.696	283.696	283.696
D/t < D/t limit	pass/fail	<b>Pass</b>	<b>Pass</b>	<b>Pass</b>	<b>Pass</b>
<b>Section Compactness Check</b>					
Parameter for Compact	$\lambda_p$	44.130	44.130	44.130	44.130
Parameter for Non-Compact	$\lambda_r$	195.435	195.435	195.435	195.435
Compactness Designation		<b>Compact</b>	<b>Compact</b>	<b>Compact</b>	<b>Compact</b>
<b>Design Strength</b>					
Yielding Strength (K')	Mp	1.994	1.615	1.364	1.169
Design Strength ( $\phi=0.9$ ) (K')	$\phi M_n$	1.794	1.454	1.227	1.052
Required Strength (K')	Mu	0.253	0.253	0.253	0.253
Utilization Ratio		<b>0.141</b>	<b>0.174</b>	<b>0.206</b>	<b>0.240</b>

## Appendix G

### Material Selection (Home Depot, 2019)



3/4 Inch Plywood



Corrugated Metal Roofing Sheets



Structural Tubing (HSS 1.9x0.188)



Metal Roofing Screws



Square U-bolt with collar



Base Plate



I-Bolt Scaffold Clamp

## References

- AISC. (2011). *Steel Construction Manual*. Chicago, Illinois.
- ASCE. (2010). *Minimum Design Loads for Buildings and Other Structures*. ASCE/SEI Standard 7-10. Reston, Va: American Society of Civil Engineers.
- Danzig, R. (2011). Driving in the Dark: Ten Propositions About Prediction and National Security. Retrieved from <http://www.cnas.org/drivinginthedark#.VTDh1JM7Wjs>
- Dinan, R.J., Coltharp, D.R., Townsend, P.T., & Watt, J.M. (2002). Exterior Building Wall Retrofits - Weapon Fragment Penetration Evaluation. *USACE/ERDC*. Vicksburg, Mississippi.
- DoD. (2011). Unified Facilities Criteria (UFC) Structural Engineering. Retrieved from <http://www.wbdg.com>
- ERDC. (2012). Modular Protective System. *USACE/ERDC*.
- Flores, O.G. (2012). Expedient Walls for Force Protection with the Modular Protective System (MPS). *ERDC*.
- Genelin, C.L. (2011). Overhead Protection for Expeditionary Shelters: Phase II. *Tyndall AFB: AFRL Materials & Manufacturing Directorate, AFRL-RX-TY*.
- Genelin, C.L., & Jordan, J.B. (2010). Overhead Protection for Expeditionary Shelters. *Tyndall AFB: AFRL Materials & Manufacturing Directorate, AFRL-RX-TY*.
- Genelin, C., & Nelson, K. (2011). *DESERT COBRA II See Inside "NOTICE AND SIGNATURE" Page for Data Rights Restrictions*. Retrieved from <http://www.dtic.mil>
- Goerger, S.R., Madni, A.M., & Eslinger, O.J. (2014). Engineered Resilient Systems: A DoD Perspective. *Procedia Computer Science*, Vol. 28:865-872.

<https://doi.org/10.1016/j.procs.2014.03.103>

Hao, H., Hao, Y., Li, J., & Chen, W. (2016). Review of the current practices in blast-resistant analysis and design of concrete structures. *Advances in Structural Engineering*, 19(8):1193-123. <https://doi.org/10.1177/1369433216656430>

Home Depot (2019). Material Images, <https://www.homedepot.com/>

Hoogenboom, P.C.J., & Spaan, R. (2005). Shear Stiffness and Maximum Shear Stress of Tubular Members, *Proceedings of the Fifteenth International Offshore and Polar Engineering Conference*, 316–319.

Hummel, J., Kerner, D., Petit, F., & Thomas, S. (2014). Final Report for the Workshop on Analytical Support for Societal and Regional Resiliency in Support of National Security, (March).

Lacey, A.W., Chen, W., Hao, H., & Bi, K. (2018). Structural response of modular buildings – An overview. *Journal of Building Engineering*, Vol. 16:45-56.  
<https://doi.org/10.1016/j.jobe.2017.12.008>

Li, G., Summers, P., Clutter, K., & Bonaventure, D. (2012). *Blast and Impact Resistant Design of Overhead Protection Structures*.

Hammons, M.I., Kensky, E.T., Dinan, R.J., and Duval, J.A. (2012). Hardened Installation Protection For Persistent for Persistent Operations (HIPPO) Joint Capability Technology Demonstration (JCTD); Interim Report 3: Status Update.

Morel, J.C., Mesbah, A., Oggero, M., & Walker, P. (2001). Building houses with local materials: means to drastically reduce the environmental impact of construction. *Building and Environment*, 36, 1119–1126. Retrieved from <http://opus.bath.ac.uk/13144/>

Neches, Robert, & Avent, R. (2011). DoD's Engineered Resilient Systems (ERS) S&T Priority.

*DoD*, (June), 1–12.

Ngo, T., Mendis, P., Gupta, A., & Ramsay, J. (2007). Blast loading and blast effects on structures - An overview. *Electronic Journal of Structural Engineering*. Special Issue - Loading on Structures, pp. 76-91

O'Connor, J.T., Rusch, S.E., & Schulz, M.J. (1987). Constructability Concepts for Engineering and Procurement. *Journal of Construction Engineering and Management*, 113(2).  
doi.org/10.1061/(ASCE)0733-9364(1987)113:2(235)

UFC 3-340-01. (2014). UFC 3-340-01. *Department of Defense (DoD)*, (May 2012), 4229.

UFC 4-020-01. (2008). UFC 4-020-01 DoD Security Engineering Facilities Planning Manual, *Department of Defense (DoD)*.

Wong, J.P. (2016). Balancing Immediate and Long-Term Defense Investments. Santa Monica, CA: RAND Corporation, 2016. Retrieved from  
[http://www.rand.org/pubs/rgs\\_dissertations/RGSD378.html](http://www.rand.org/pubs/rgs_dissertations/RGSD378.html)

## **Vita**

Captain Zachary John Spranger entered undergraduate studies at the USAFA where he graduated with a Bachelor of Science degree in Civil Engineering in May 2014 where he was commissioned. His first assignment was at Dyess AFB, Texas as a Civil Engineer Officer in July 2014. He was assigned to the 7th Civil Engineer Squadron, where he served as an Engineering Flight Programmer, OIC of Construction Inspection, CSS Section Commander, and Readiness Flight Chief. While stationed at Dyess, he deployed overseas in October 2015 to spend six months in Bagram, Afghanistan as the Operations Flight Commander. In August 2016, he entered the Graduate School of Engineering and Management, Air Force Institute of Technology. Upon graduation, he will be assigned 554th Red Horse Squadron in Guam.

**REPORT DOCUMENTATION PAGE**

Form Approved  
OMB No. 0704-0188

The public reporting burden for this collection of information is estimated to average 1 hour per response, including the time for reviewing instructions, searching existing data sources, gathering and maintaining the data needed, and completing and reviewing the collection of information. Send comments regarding this burden estimate or any other aspect of this collection of information, including suggestions for reducing the burden, to Department of Defense, Washington Headquarters Services, Directorate for Information Operations and Reports (0704-0188), 1215 Jefferson Davis Highway, Suite 1204, Arlington, VA 22202-4302. Respondents should be aware that notwithstanding any other provision of law, no person shall be subject to any penalty for failing to comply with a collection of information if it does not display a currently valid OMB control number.

**PLEASE DO NOT RETURN YOUR FORM TO THE ABOVE ADDRESS.**

<b>1. REPORT DATE (DD-MM-YYYY)</b> 21-03-2019		<b>2. REPORT TYPE</b> Master's Thesis		<b>3. DATES COVERED (From - To)</b> August 2017 - March 2019	
<b>4. TITLE AND SUBTITLE</b> Analysis and Design of Modular Overhead Protection System Utilizing Readily Available Materials				<b>5a. CONTRACT NUMBER</b>	
				<b>5b. GRANT NUMBER</b>	
				<b>5c. PROGRAM ELEMENT NUMBER</b>	
<b>6. AUTHOR(S)</b> Spranger, Zachary J., Capt, USAF				<b>5d. PROJECT NUMBER</b>	
				<b>5e. TASK NUMBER</b>	
				<b>5f. WORK UNIT NUMBER</b>	
<b>7. PERFORMING ORGANIZATION NAME(S) AND ADDRESS(ES)</b> Air Force Institute of Technology Graduate School of Engineering and Management (AFIT/EN) 2950 Hobson Way Wright-Patterson AFB OH 45433-7765				<b>8. PERFORMING ORGANIZATION REPORT NUMBER</b> AFIT-ENV-MS-19-M-198	
<b>9. SPONSORING/MONITORING AGENCY NAME(S) AND ADDRESS(ES)</b> Air Force Civil Engineer Center Jeffrey P. Nielsen 139 Barnes Ave, Suite 1 Tyndall, FL, 32403 jeffrey.nielsen@us.af.mil				<b>10. SPONSOR/MONITOR'S ACRONYM(S)</b> AFCEC	
				<b>11. SPONSOR/MONITOR'S REPORT NUMBER(S)</b>	
<b>12. DISTRIBUTION/AVAILABILITY STATEMENT</b> Distribution Statement A. Approved for Public Release; Distribution Unlimited					
<b>13. SUPPLEMENTARY NOTES</b> This work is declared a work of the U.S. Government and is not subject to copyright protection in the United States."					
<b>14. ABSTRACT</b> This research investigated passive overhead protective measures for existing facilities in urban environments vulnerable to enemy munitions fire. A new modular structural system was designed utilizing commercially available construction materials consisting of structural tubing, scaffolding clamps, base plates, and simple roofing components. Structural analysis software was used to model nine modular structures to understand the relationship between the load bearing capacity of the structural members and overall dimensions of the system. Environmental variables for the models were set to the Parwan Province in Afghanistan; this region presents worst-case scenarios both for environmental factors and threat of enemy fire. For the final design, the members were sized according to the maximum axial, shear, and flexural forces exposed to a single member. Preliminary findings show that commercially available materials can be used to quickly, efficiently, and cost-effectively install overhead protection in austere hostile environments.					
<b>15. SUBJECT TERMS</b> modular structural system, overhead protective measures, commercially available material, austere hostile environments					
<b>16. SECURITY CLASSIFICATION OF:</b>			<b>17. LIMITATION OF ABSTRACT</b> UU	<b>18. NUMBER OF PAGES</b> 86	<b>19a. NAME OF RESPONSIBLE PERSON</b> Alfred E. Thal, Jr., PhD, AFIT/ENV
<b>a. REPORT</b> U	<b>b. ABSTRACT</b> U	<b>c. THIS PAGE</b> U			<b>19b. TELEPHONE NUMBER (Include area code)</b> (937) 255-3636 x7401 al.thal@afit.edu