



**NAVAL  
POSTGRADUATE  
SCHOOL**

**MONTEREY, CALIFORNIA**

**THESIS**

**HARVESTING WASTE THERMAL ENERGY FROM  
MILITARY SYSTEMS**

by

Rondolf J. Moreno

June 2019

Thesis Advisor:  
Co-Advisor:  
Second Reader:

Anthony G. Pollman  
Dragoslav Grbovic  
Mark Stevens

**Approved for public release. Distribution is unlimited.**

THIS PAGE INTENTIONALLY LEFT BLANK

<b>REPORT DOCUMENTATION PAGE</b>			<i>Form Approved OMB No. 0704-0188</i>	
Public reporting burden for this collection of information is estimated to average 1 hour per response, including the time for reviewing instruction, searching existing data sources, gathering and maintaining the data needed, and completing and reviewing the collection of information. Send comments regarding this burden estimate or any other aspect of this collection of information, including suggestions for reducing this burden, to Washington headquarters Services, Directorate for Information Operations and Reports, 1215 Jefferson Davis Highway, Suite 1204, Arlington, VA 22202-4302, and to the Office of Management and Budget, Paperwork Reduction Project (0704-0188) Washington, DC 20503.				
<b>1. AGENCY USE ONLY (Leave blank)</b>		<b>2. REPORT DATE</b> June 2019	<b>3. REPORT TYPE AND DATES COVERED</b> Master's thesis	
<b>4. TITLE AND SUBTITLE</b> HARVESTING WASTE THERMAL ENERGY FROM MILITARY SYSTEMS			<b>5. FUNDING NUMBERS</b>  R5LYL	
<b>6. AUTHOR(S)</b> Rondolf J. Moreno				
<b>7. PERFORMING ORGANIZATION NAME(S) AND ADDRESS(ES)</b> Naval Postgraduate School Monterey, CA 93943-5000			<b>8. PERFORMING ORGANIZATION REPORT NUMBER</b>	
<b>9. SPONSORING / MONITORING AGENCY NAME(S) AND ADDRESS(ES)</b> N/A			<b>10. SPONSORING / MONITORING AGENCY REPORT NUMBER</b>	
<b>11. SUPPLEMENTARY NOTES</b> The views expressed in this thesis are those of the author and do not reflect the official policy or position of the Department of Defense or the U.S. Government.				
<b>12a. DISTRIBUTION / AVAILABILITY STATEMENT</b> Approved for public release. Distribution is unlimited.			<b>12b. DISTRIBUTION CODE</b> A	
<b>13. ABSTRACT (maximum 200 words)</b>  Military systems greatly depend on the availability of energy. This energy comes mostly in the form of burning fuel in order to produce mechanical work or electricity. The ability to extract the most out of these systems aligns with the current focus of energy efficiency, not only in the military but also in society at-large. This research used a commercial thermoelectric generator (TEG) to produce an output baseline for the technology. Using an apparatus to produce heat and analyze the output, calculations performed produced correlation coefficients. These coefficients modeled a virtual TEG in COMSOL and yielded 0.72W of power. A simple design using simple calculations yielded 72W of power with 100 modules joined in 10 sets coupled in parallel, with each set containing 10 modules in coupled in series. More robust modeling and simulation design further created models that refine the design process when creating a TEG array. By building these robust design models, a systems engineer would better understand the trade space when applying this technology to a system. Additionally, the models presented in this paper can form the basis by which to explore the application of TEGs on systems. As TEGs passively convert thermal energy into electricity, a possible intrinsic benefit appears. The thermal energy converted would reduce the thermal signature of the system.				
<b>14. SUBJECT TERMS</b> thermal signature, energy, energy recovery bismuth telluride, energy conversion, heat transfer, heat recovery, thermal conductivity, thermal, thermal power, modeling, thermoelectric, thermoelectric generator, simulation, Seebeck effect			<b>15. NUMBER OF PAGES</b> 69	
			<b>16. PRICE CODE</b>	
<b>17. SECURITY CLASSIFICATION OF REPORT</b> Unclassified	<b>18. SECURITY CLASSIFICATION OF THIS PAGE</b> Unclassified	<b>19. SECURITY CLASSIFICATION OF ABSTRACT</b> Unclassified	<b>20. LIMITATION OF ABSTRACT</b>  UU	

THIS PAGE INTENTIONALLY LEFT BLANK

**Approved for public release. Distribution is unlimited.**

**HARVESTING WASTE THERMAL ENERGY FROM MILITARY SYSTEMS**

Rondolf J. Moreno  
Captain, United States Army  
BS, Hofstra University, 2010

Submitted in partial fulfillment of the  
requirements for the degree of

**MASTER OF SCIENCE IN SYSTEMS ENGINEERING**

from the

**NAVAL POSTGRADUATE SCHOOL  
June 2019**

Approved by: Anthony G. Pollman  
Advisor

Dragoslav Grbovic  
Co-Advisor

Mark Stevens  
Second Reader

Ronald E. Giachetti  
Chair, Department of Systems Engineering

THIS PAGE INTENTIONALLY LEFT BLANK

## **ABSTRACT**

Military systems greatly depend on the availability of energy. This energy comes mostly in the form of burning fuel in order to produce mechanical work or electricity. The ability to extract the most out of these systems aligns with the current focus of energy efficiency, not only in the military but also in society at-large. This research used a commercial thermoelectric generator (TEG) to produce an output baseline for the technology. Using an apparatus to produce heat and analyze the output, calculations performed produced correlation coefficients. These coefficients modeled a virtual TEG in COMSOL and yielded 0.72W of power. A simple design using simple calculations yielded 72W of power with 100 modules joined in 10 sets coupled in parallel, with each set containing 10 modules in coupled in series. More robust modeling and simulation design further created models that refine the design process when creating a TEG array. By building these robust design models, a systems engineer would better understand the trade space when applying this technology to a system. Additionally, the models presented in this paper can form the basis by which to explore the application of TEGs on systems. As TEGs passively convert thermal energy into electricity, a possible intrinsic benefit appears. The thermal energy converted would reduce the thermal signature of the system.

THIS PAGE INTENTIONALLY LEFT BLANK

# TABLE OF CONTENTS

<b>I.</b>	<b>INTRODUCTION.....</b>	<b>1</b>
<b>A.</b>	<b>PROBLEM STATEMENT .....</b>	<b>1</b>
<b>B.</b>	<b>PROBLEM DESCRIPTION.....</b>	<b>1</b>
<b>C.</b>	<b>RESEARCH QUESTIONS.....</b>	<b>2</b>
<b>D.</b>	<b>SCOPE AND METHODOLOGY .....</b>	<b>2</b>
<b>II.</b>	<b>PAPER I: HARVESTING WASTE THERMAL ENERGY FROM MILITARY SYSTEMS.....</b>	<b>7</b>
<b>A.</b>	<b>ABSTRACT.....</b>	<b>7</b>
<b>B.</b>	<b>BACKGROUND AND MOTIVATION .....</b>	<b>8</b>
<b>C.</b>	<b>EXPERIMENTAL CHARACTERIZATION OF A TEG .....</b>	<b>11</b>
<b>D.</b>	<b>CHARACTERIZATION DATA AND ANALYSIS .....</b>	<b>14</b>
<b>E.</b>	<b>MODELING AND SCALED APPLICATION .....</b>	<b>16</b>
<b>F.</b>	<b>FUTURE WORK.....</b>	<b>18</b>
<b>G.</b>	<b>CONCLUSION .....</b>	<b>19</b>
<b>III.</b>	<b>PAPER II: USING MODELING AND SIMULATIONS TO CHARACTERIZE TEG ARRAYS.....</b>	<b>21</b>
<b>A.</b>	<b>ABSTRACT.....</b>	<b>21</b>
<b>B.</b>	<b>INTRODUCTION.....</b>	<b>22</b>
<b>C.</b>	<b>BACKGROUND .....</b>	<b>22</b>
<b>1.</b>	<b>Modeling in the Systems Engineering Process .....</b>	<b>23</b>
<b>2.</b>	<b>Thevenin Equivalent Resistance.....</b>	<b>24</b>
<b>3.</b>	<b>Regression Analysis .....</b>	<b>24</b>
<b>D.</b>	<b>OPEN CIRCUIT CHARACTERIZATION.....</b>	<b>25</b>
<b>E.</b>	<b>MODELING AND SIMULATION.....</b>	<b>26</b>
<b>F.</b>	<b>ANALYSIS OF MODELS .....</b>	<b>28</b>
<b>G.</b>	<b>MODELING AND SIMULATING ARRAYS .....</b>	<b>30</b>
<b>H.</b>	<b>FUTURE WORK.....</b>	<b>33</b>
<b>I.</b>	<b>CONCLUSION .....</b>	<b>34</b>
<b>IV.</b>	<b>CONCLUSION .....</b>	<b>37</b>
	<b>APPENDIX. OPEN CIRCUIT DATA .....</b>	<b>39</b>
	<b>LIST OF REFERENCES.....</b>	<b>43</b>
	<b>INITIAL DISTRIBUTION LIST .....</b>	<b>47</b>

THIS PAGE INTENTIONALLY LEFT BLANK

## LIST OF FIGURES

Figure 1.	The systems engineering “vee” model with highlight of areas that this research addresses. Adapted from Department of Transportation (2007).....	4
Figure 2.	Generator FLIR map at steady state.....	11
Figure 3.	Experimental apparatus of characterization.....	12
Figure 4.	Plot of current against the temperature differential for each resistor used .....	14
Figure 5.	Thermal gradient at the edge of a single TEG module .....	16
Figure 6.	An army generator on the left (US Army 2012) and a naval turbine on the right (Stewart 2016) .....	17
Figure 7.	Setup of experimental characterization system (Moreno, Pollman, and Grbovic 2018). .....	25
Figure 8.	Layout of a single TEG module in PSPICE.....	27
Figure 9.	PSPICE model overlay on the data for voltage found at the resistive load.....	29
Figure 10.	PSPICE model overlay on the data for voltage in the equivalent circuit .....	29
Figure 11.	Power output curves for parallel-attached TEGs .....	31
Figure 12.	Power output curves for series-attached TEGs.....	31
Figure 13.	Power output curves for parallel-attached TEGs based on the number of modules.....	32
Figure 14.	Power output curves for series-attached TEGs based on the number of modules.....	33
Figure 15.	Image that displays the use of camouflaging thermal signatures. (Eshel 2011) .....	34

THIS PAGE INTENTIONALLY LEFT BLANK

## LIST OF TABLES

Table 1.	Testing matrix .....	13
Table 2.	Summary of characterization results at maximum temperature difference .....	15
Table 3.	Summary of regression analysis .....	15
Table 4.	Average hot side temperature of differently arrayed TEGs.....	17
Table 5.	Summary of R-squared values .....	28
Table 6.	Power (W) at 115°C temp. diff. ....	30

THIS PAGE INTENTIONALLY LEFT BLANK

## LIST OF ACRONYMS AND ABBREVIATIONS

Be <sub>2</sub> Te <sub>3</sub>	bismuth telluride
C	specific heat
CI	confidence interval
DoD	Department of Defense
FLIR	forward looking infrared
HVAC	heating, ventilation, and air conditioning
IR	infrared
$i_{load}$	current with the resistive load
m	mass
n	number of data points
MBSE	Model-Based Systems Engineering
Q	heat supplied/emitted
$R_{eq}$	equivalent resistance
s	sample standard deviation
Se	standard error
Sxx	sum of squares
$t_{\alpha/2, n-1}$	critical point
$T_c$	temperature of the cold side
$T_h$	temperature of the hot side
$T_{diff}$	temperature difference
TEG	thermoelectric generator
v	voltage
$v_{oc}$	voltage of the open circuit (no resistive load)
$v_{load}$	voltage with the resistive load
$x^*$	a particular value
$\bar{x}$	sample mean
$y_i$	$i$ th data point
$\hat{y}_i$	$i$ th modeled response
$\bar{y}$	mean of all data points
ZT	thermoelectric figure of merit

THIS PAGE INTENTIONALLY LEFT BLANK

## EXECUTIVE SUMMARY

Military systems consume a large amount of energy to operate in the battlefield. By reducing the amount of energy needed by these systems, military forces are able to extend their reach with less reliance on the supply chain. The reduction in resupply operations would reduce the exposure of personnel and equipment used in those operations. Considering the sheer magnitude of energy rejected as heat and its environment in the sea, which can be considered a large, cool heat sink in ship engines, as well as electronic warfare and communication systems, it is worthwhile to attempt to recapture some of this energy and put it to beneficial use. In the case of communication equipment, this heat also results in a large energy demand for cooling. Efforts to capture and use some of this waste energy are akin to reheating techniques used to improve steam power plant efficiencies.

One technology that can capture that thermal energy is thermoelectric generators (TEG). They comprise P-type and N-type semiconductors joined at the ends. The constructed TEG is a wafer structure, normally built as a plate. When exposed to a thermal source, the temperature difference between the two sides produces an electrical current. An application of a heat sink on the cool side would increase the temperature difference and hence produce more electrical current.

Using this technology in military systems would require a methodical and carefully planned process to ensure that it meets specifications in capturing a system's thermal energy. However, just because engineers built a TEG system correctly does not mean that they built the right system for the requirements. The systems engineering process influences how engineers build systems by ensuring that the system meets the requirements set forth by the customer throughout the timeline. This reduces the resources required to build a system, as there are fewer changes to the system in the later stages of conception and testing, where cost, time, and effort are the greatest when making changes.

Model-Based Systems Engineering (MBSE) allows for a greater sense of total system integration. Scoping the problem is necessary in MBSE, just as in the systems engineering process. The feasibility study this research covers helps to scope the problem

down to the basics of understanding the type of output TEG modules provide. By using models to understand the problem, engineers could also use those same models to understand the effects of input changes to the problem. Engineers could explore the changes in the number of modules in an array or the type of spacing between the modules themselves. This results in driving down the cost of design or engineering a solution that optimizes the system to fit the requirements. Proper modeling that takes advantage of automation and analysis of computer tools provides a complete virtual picture of the applied system. It predicts how the final system will look and establishes a clear path for the engineers and designers to work toward a final system design.

By characterizing a commercial TEG and building high-level models that mimic the output of those modules, designers and engineers have a foundation in which to design an array that meets a given requirement. Iterative modeling and simulation of various complex, yet practical, TEG array configurations could be conducted with both COMSOL and PSPICE in order to predict the configuration that optimizes power output for a given number of arrayed TEG elements on a heat source. The results could facilitate the assessment of the efficacy of harvesting waste heat with TEGs for particular systems in the acquisition process. These are the technical baselines that are also needed to maintain a high level of understanding in the MBSE process.

This research focused on the application of this technology through two conference papers. The first was presented at the ASME's 2018 Power and Energy Conference in Buena Vista Lake, FL, and used the experimental and analysis method to characterize commercial-off-the-shelf TEG response (voltage, current, and power) for temperature differences observed near a heat engine. To understand the output and effects of utilizing TEGs, an experimental testbed designed for this research collected the input and output data of a singular TEG. This data fed into a physics simulation software called COMSOL and analyzed the specific effects of thermal absorption by the TEG module. This became the basis to analyze the system as it is scaled into different sized arrays. Arrays arranged in four, six, and nine modules in the simulation indicated the aggregate heat absorbed through the modules and translated to power using the characterization data. Basic electrical

calculations established ideas of the type of power output that a basic array design could produce.

Based on the commercial TEG used, the module can reach a theoretical temperature output of 300°C and produce 22W of power. Under characterization testing, a temperature difference of 115°C produced only 0.72W. Applied to large systems, an array of 100 modules can provide 72W of power with modules built in series and in parallel. This could be feasible for the amount of energy recovered, as this output would be enough to light five 100W equivalent LED light bulbs.

If this technology is developed further to improve the efficiency of the modules, an application to all heat producing systems could prove worthwhile. Currently, it may not be feasible to implement it, but it can provide a passive source of increasing system efficiency.

The second conference paper presented in the Innovative Applied Energy's 2019 Conference held in Oxford, England focused on design and trade space analysis through the experimental and design method using PSPICE modeling that analyzed the effects of arranging modules in series and in parallel circuits. To build a complete model, PSPICE needed additional characterization data. A modified form of the experimental testbed from the first conference paper provided the needed data. This fed into the PSPICE program, which produced models suitable for simulating differently configured arrays. These models were high-level tools that would influence design and physical prototype models. Specifically, those models were tradeoff curves that would allow an engineer or a designer to build a TEG array design that best suited a requirement. This is akin to understanding the technology and its output characteristics that influence the technology readiness levels found in the beginning of a systems engineering or systems acquisition process.

This conference paper also explored the use of models that fit the application. It explored the mantra that "less is more" when applied to modeling and showed that basic models are all that's needed to make initial design and engineering decisions. Although there is validity in complex models, basic models drive the system design early in the design process without spending excess time, labor, and money. This conference paper

answers questions about the system early and could help scope design characteristics for engineers.

TEGs signify a technology that is still immature and inefficient in converting thermal energy. However, they do provide an interesting concept worth exploring. By converting thermal energy into electricity, TEGs effectively reduce the thermal signature of a system. This increases the survivability of that system operating in the battlefield. The research conducted in this paper and its relation within the model-based systems engineering provide the foundation to further explore the possibility of using TEG's secondary trait to reduce thermal signatures. A recommendation would be to further explore new materials for TEGs and further the research done in this paper to assess the feasibility of those new materials.

## References

- Moreno, Rondolf, Dragoslav Grbovic, and Anthony Pollman. 2019. "Using Modeling and Simulations to Characterize TEG Arrays." In *Proceedings of the International Conference of Innovative Applied Energy 2019 1* (IAPE2019): 1–5., Oxford, UK. [http://iape-conference.org/Downloads/Proceedings/Articles%20\(Abstracts%20&%20Papers\)/a-1-Article-051.pdf](http://iape-conference.org/Downloads/Proceedings/Articles%20(Abstracts%20&%20Papers)/a-1-Article-051.pdf).
- Moreno, Rondolf J., Anthony G. Pollman, Dragoslav Grbovic. 2018. "Harvesting Waste Thermal Energy from Military Systems." In *Proceedings of the ASME Power and Energy Conference 2018 2* (Power2018-7514): 1–6., Lake Buena Vista, FL. <http://proceedings.asmedigitalcollection.asme.org/proceeding.aspx?articleid=2706310&resultClick=3>.

## **ACKNOWLEDGMENTS**

I want to acknowledge my mother, Elizabeth Noblejas, for raising me to be whom I am today. Without her sacrifice and love, I would not be here today.

Furthermore, this research was funded by the Office of Naval Research and much thanks to their efforts in providing the opportunity to pursue this field.

THIS PAGE INTENTIONALLY LEFT BLANK

# I. INTRODUCTION

## A. PROBLEM STATEMENT

New technologies and approaches are needed to realize greater energy efficiency to enable operational resilience. In light of the large amounts of waste heat generated by military systems, thermoelectric generators (TEG) hold promise as a way to use energy more efficiently with that added operational bonus of decreasing thermal signatures.

## B. PROBLEM DESCRIPTION

Many military systems rely on heat engines burning fossil fuels for operation. This reliance necessitates a robust logistics or supply chain infrastructure that burns fossil fuels to support the use of fossil fuels. The Navy seeks to reduce this reliance by creating initiatives to move the fleet to more sustainable, and energy secure, power sources (Bigger and Neimark 2017). Even with continued use of fossil fuels, increases in efficiency would better support the military's operational need to move forces across the battlefield. Efficiency gains imply the double-gain of reducing the demand for fuel and the logistics requirements for moving the fuel. One promising method of increasing efficiency in heat engines is the application of TEGs to harvest low-entropy waste heat.

TEGs leverage the Seebeck effect to generate an electric current from temperature differences between dissimilar metals joined at a junction (Reddy et al. 2013). TEGs have historically been used to power small, remote sensors in harsh environments like outer space, deep oceans, and isolated airfields (Davenport 2004). Due to their passive nature, they are able to be included in system designs with minimal impact. Additionally, recovery of waste heat with TEGs exhibit the secondary benefit of reducing infrared signatures.

Considering the sheer magnitude of energy rejected as heat (and its environment in the sea which can be considered a large, cool heat sink) in ship engines, as well as electronic warfare and communication systems, it is worthwhile to attempt to capture some of this energy and put it to beneficial use. In the case of communication equipment, this heat also results in a large energy demand for cooling. Efforts to capture and use some of this waste energy are akin to reheating techniques used to improve steam power plant efficiencies.

## **C. RESEARCH QUESTIONS**

Within the larger context of military systems, diesel-electric generators are ubiquitous. To manage scope, this research focused military generators. In order to assess the feasibility of applying TEGs to existing generator systems, this thesis proposed the following questions:

1. Can modeling and simulation be used to quantify the output of a TEG or TEG array employed as part of a generator system?
2. Is waste heat recovery from a generator with a TEG array practical?
3. What temperature ranges can be expected during normal operations of a representative generator?
4. What is the steady state power output for a single TEG module given these temperature differences?

## **D. SCOPE AND METHODOLOGY**

At the Naval Postgraduate School of Systems Engineering, there are four categories of research methods for theses identified by the department. These are experimental, empirical, design, and analysis theses. Research conducted could utilize a single method or multiple methods, based on the research conducted. This thesis utilizes the experimental, design, and analysis methods to compile the data born from the research.

This two conference paper thesis analyzed the feasibility of applying TEG technology to military systems by employing modeling and simulation to inform the systems engineering process.

The first conference paper used the experimental and analysis approaches to characterize commercial-off-the-shelf TEG response (voltage, current, and power) for temperature differences observed near a given heat engine. To understand the output and effects of utilizing TEGs, an experimental testbed designed for this research collected the input and output data of a single TEG. This data was used as input into the COMSOL Multi-Physics software suite to gain insight into the specific effects of thermal absorption

by a TEG module. The results became the basis for analysis of a system scaled to differently sized arrays. Simulated arrays for four, six, and nine modules indicated the aggregate heat absorbed and the resulting power output. Basic electrical calculations benchmarked the magnitude of the power output for a given array design. This conference paper was presented at the ASME's 2018 Power and Energy Conference in Buena Vista Lake, FL.

The second conference paper focused on design and trade space analysis using a PSPICE model that simulated the effects of arranging modules in various serial and parallel configurations. To build a complete model, PSPICE needed additional characterization data. A modified form of the original (described in the first paper) experiment provided the needed data. The data was input into PSPICE, which produced models suitable for simulating differently configured arrays. These models were high-level tools that would influence design and physical prototype models. This is akin to understanding the technology and its output characteristics that influence the technology readiness levels found in the beginning of a systems engineering or systems acquisition process. This conference paper was accepted for presentation at IAPE's International Conference on Innovative Applied Energy at Oxford University (UK) in March 2019.

Engineering a system requires a methodical and carefully planned process to ensure that it meets specifications. However, just because engineers built a system correctly does not mean that they built the right system for the requirement. The systems engineering process influences how engineers build systems by ensuring that the system meets the requirements set forth by the customer throughout the development life cycle.

Figure 1 shows the systems engineering "vee." The vee splits the systems engineering effort into two legs, decomposition-definition and integration-qualification, with feedback loops throughout. Although this is not the only model that systems engineers employ, it is one of the more recognizable within the field. The model allows for validation and verification of the system against design specifications and against the customer requirements as prototypes emerge and testing is completed. By allowing for verification of the system against design requirements and the validation of the requirements against

the customer’s needs, it reduces the amount of unforeseen changes to the design and the associate cost and time overruns due to those changes.

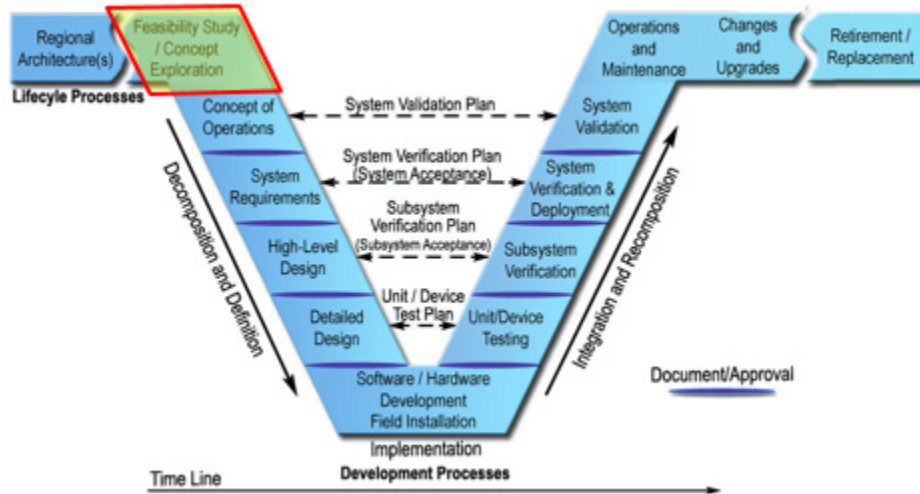

Figure 1. The systems engineering “vee” model with highlight of areas that this research addresses. Adapted from Department of Transportation (2007).

This research effort focused on, and contributed to, the feasibility study/concept exploration phase of the systems engineering process. Although systems engineering is not necessarily practiced in academic research, there is basis for its use. For example, the Office of Naval Research has built programs that sponsor academic institutions to further current enterprise energy initiatives. These programs drive research that could eventually find itself implemented in current or new designs within the fleet and beyond. Thus, academic research performed under these programs has the potential to inform or drive design and system development. In particular, this type of sponsored research contributes to the necessary foundational work needed to establish technology readiness levels (Department of Defense 2017). Ultimately, research informs and validates the feasibility of a given technology for meeting military requirements.

Model-Based Systems Engineering (MBSE) allows for a greater insight into total system integration, while reducing cost and risk. Scoping the problem is necessary in MBSE, just as in the systems engineering process. The current effort helps to scope the

problem and gain a better understanding of the potential use of TEGs to meet Navy requirements. Using modeling and simulations to understand the problem, engineers can also use those same models to understand the effects of input changes. For example, engineers can explore the changes in the number of modules in an array or the type of spacing between the modules themselves. This results in driving down the cost of design or engineering a solution that optimizes the system to fit a given requirement. Proper modeling that takes advantage of automation and analysis of computer tools provides a complete virtual picture of the applied system. It informs the final form, fit and function, as well as establishes a clearer path for the engineers and designers to work toward a final product.

By characterizing a commercial TEGs, and building high-level models that mimic the output of those modules, designers and engineers are armed with the foundation necessary to design an array that meets warfighter requirements. Iterative modeling and simulation of various complex, yet practical, TEG array configurations could be conducted with both COMSOL and PSPICE in order to predict the configuration that optimizes power output for a given number of arrayed TEG elements on a heat source. The results could facilitate the assessment of the efficacy of harvesting waste heat with TEGs for particular systems in the acquisition process. These are the technical baselines that are also needed to maintain a high level of understanding in the MBSE process. The MBSE process is the formalized application of modeling to support system requirements, design, analysis, verification and validation activities beginning in the conceptual design phase and continuing throughout development and later life cycle phases (Hart 2015).

THIS PAGE INTENTIONALLY LEFT BLANK

## II. PAPER I: HARVESTING WASTE THERMAL ENERGY FROM MILITARY SYSTEMS

This chapter was previously published as: Rondolf J. Moreno, Anthony G. Pollman, Dragoslav Grbovic. 2018. “Harvesting Waste Thermal Energy from Military Systems.” In *Proceedings of the ASME Power and Energy Conference 2018 2* (Power2018-7514): 1–6., Lake Buena Vista, FL. Re-print permission was granted by ASME on June 28, 2018. Copyright does not apply in the United States but does apply internationally.

### A. ABSTRACT

Military systems greatly depend on the availability of energy. This energy comes mostly in the form of burning fuel in order to produce mechanical work or producing electricity. The ability to extract the most out of these systems aligns with the current focus of energy efficiency, not only in the military, but in society at-large. In this research, an infrared camera was used to create an infrared map to infer temperature differences on the gasoline-powered generator at steady state operations. These temperature differences were inputted into an experimental phase during which a digitally controlled hot plate, water block, variable resistor, and digital acquisitions system were used to measure current output from a single TEG for loads of 1, 10, and 100 ohms, respectively. Data were analyzed and the correlation coefficients determined. These coefficients were modeled a single module and then various array configurations for TEGs in COMSOL. Using the findings, a single commercial 56 mm by 56 mm  $\text{Be}_2\text{Te}_3$  TEG can yield 0.72W of power. Simple calculations yield 72W of power when 100 modules are joined in 10 sets coupled in parallel with each set containing 10 modules in coupled in series. This would require 560 mm by 560 mm or approximately 2 ft. by 2 ft. of system space to be covered.

*Keywords: bismuth telluride, energy conversion, heat transfer, heat recovery, thermal conductivity, thermal, thermal power, modeling, thermoelectric, thermoelectric generator, simulation, Seebeck effect*

## B. BACKGROUND AND MOTIVATION

Thermoelectric generators (TEG) have been around since 1800s (*Hutchinson Unabridged Encyclopedia* 2016). However, they have not been extensively developed. As early as 2000, they only yielded a small percentage of recovered energy (Percy, et al. 2014). Currently, the common commercial material for TEGs is  $\text{Be}_2\text{Te}_3$  (Tian, Lee and Chen 2013). This is the same composition as the TEGs used in this research (TEG Pro TE-MOD-22W7V-56) and can produce up to 22W with a temperature difference of  $270^\circ\text{C}$  (TEG Modules 2014). These type of conventional bulk TEGs can yield up to a 5% - 15% recovery of energy from a thermal source (Reddy, et al. 2013). Schock revealed that when applied to a system such as a commercial truck, the technology reduced fuel usage by 2%; a savings of 4,000 gallons of fuel over 1 million miles (Schock, et al. 2013). Schock also stated that when coupled with an auxiliary power unit, a TEG can obtain a 7% efficiency. With more improvements, thermoelectric devices like those described can become a viable source of energy or a way to improve the efficiency of energy use. This is seen in Crane and Lagrandeur's paper (Crane and LaGrandeur 2010), where they designed a TEG that is able to handle up to  $650^\circ\text{C}$  and produce 125W of power for use in automotive applications. With the development of new materials, TEGs could provide more efficient energy recovery.

There are two phenomenon that govern the behavior of thermoelectric devices. The first type is the Peltier effect, which uses P-N junctions assembled in series to transform electrical energy that passes through it to create a temperature difference between the two sides of the module. This creates a cooling effect on one side of the module. The second effect is called the Seebeck effect. It is the opposite of how the Peltier effect works in that it uses a temperature difference between the two sides to create electricity.

TEGs are the type of thermoelectric devices that work on the Seebeck effect and are governed by the following equation:

$$v = \beta(T_h - T_c) \quad (1)$$

where  $v$  is the voltage across the thermoelectric module,  $\beta$  is the Seebeck coefficient,  $T_h$  is the temperature at the hot side, and  $T_c$  is the temperature at the cold side (Korprasertsak

and Leephakpreeda 2017). This relationship between  $v$  and  $\Delta T$  are linearly proportional. In order to characterize TEG behavior, the coefficient  $\beta$  must be determined through experimentation. This coefficient can then model the TEG in simulations.

Heat is another important concept in the analysis of efficiency of TEGs. Specific heat capacity is governed by the following equation:

$$Q = mC\Delta T \quad (2)$$

where  $Q$  is the heat supplied to the system or object,  $m$  is the mass of the object,  $C$  is the specific heat of the object, and  $\Delta T$  is the temperature change of the object (Timings and Twigg 2001). Using this equation with the International System of Units (SI), yields kcal.

Next, the determination of efficiency for thermoelectric materials can be governed by the dimensionless figure-of-merit  $ZT$ ,

$$ZT = \frac{\beta^2 \sigma}{\kappa} T \quad (3)$$

where  $\sigma$  is the electrical conductivity,  $\beta^2 \sigma$  is the power factor, and  $\kappa$  is the thermal conductivity (Tian, Lee and Chen 2013). This  $ZT$  factor is important in producing good thermoelectric material, and different alloys can produce a significant difference in the efficiency of heat conversion. Tian additionally states that current  $\text{Be}_2\text{Te}_3$  materials have a  $ZT$  factor around 1 whereas more revolutionary alloys have produced  $ZT$  factors up to 2.2 (Tian, Lee and Chen 2013).

Additionally, some statistical work is implemented to test the linear model. Standard error is calculated using

$$S_e = \sigma \sqrt{\frac{1}{n} + \frac{(x^* - \bar{x})^2}{S_{xx}}} \quad (4)$$

where  $\sigma$  is the standard deviation,  $n$  is the number of data points,  $x^*$  is a particular value,  $\bar{x}$  is the sample mean, and  $S_{xx}$  is the sum of squares (Hayter 2012). The confidence interval is also calculated in the regression analysis,

$$\mu \in \left( \bar{x} - \frac{t_{\alpha/2, n-1} S}{\sqrt{n}}, \bar{x} + \frac{t_{\alpha/2, n-1} S}{\sqrt{n}} \right) \quad (5)$$

where  $\mu$  is the population mean,  $n$  is the number of data points,  $\bar{x}$  is the sample mean,  $s$  is the sample standard deviation, and  $t_{\alpha/2, n-1}$  is the critical point (Hayter 2012).

In the military, energy is a large facet of operations. Most energy is produced through the burning of fossil fuels in power generators, motor engines, and turbines. Reliance on fossil fuels burdens logistics channels that provide that fuel and limits the capability of these systems. Designing systems for efficiency and implementing energy savings measures would allow these systems to go farther or operate longer before refueling, extending a military unit's operational reach (Pollman 1997). As a result, the military is pursuing options to improve the efficiency of all systems it operates. These options are intended to improve the warfighting capability of the military and to add to the advantage that a warfighter has in combat. Applying devices such as TEGs would support the military's energy initiatives by providing an incremental improvement in the efficiency of some military systems. As described before, thousands of gallons of fuel could be saved, which could reduce the need to bring fuel to the battlefield. The risks to the warfighter providing this logistics are inherently reduced, which in turn may save lives on today's battlefields.

Secondary effects from using TEGs could be from the reduction of infrared (IR) signatures. Military systems all produce some form of signature, from electrical to radar signatures. IR is produced from the generation of heat by some of these systems. Due to the conservation of energy, the thermal energy that the TEG converted to electricity would dissipate. This dissipation is essentially a reduction in IR output. Thus, the potential of reducing an IR signature of a military system is possible. This reduction allows a form of stealth in that signature region. If an IR signature can be fully masked and blend in with the environment, it essentially becomes "invisible" to sensors that detect IR. This provides an advantage to friendly forces operating in the battlefield.

Not only is energy important in the military, but it continues to be a priority in multiple industries today. Research spanned from recovering heat in truck applications

(Ikoma, et al. 1998) to the use of thermoelectric materials to power everyday objects such as mobile phones (Anatychuk, Mykhailovsky and Strutynska 2011). This field is still untapped and could potentially be an emerging technology in the field of power generation. Its application could help to extract the most out of any system that produces thermal energy as a byproduct.

### C. EXPERIMENTAL CHARACTERIZATION OF A TEG

Using a portable gasoline-fueled electric generator as a baseline, a range of temperature values are established for analysis. The generator was setup in a shaded location to prevent thermal absorption from the sun, and a Forward Looking Infrared (FLIR) device highlighted the different heat gradients in the generator from multiple sides. A FLIR device uses a sensor that detects thermal radiation and can apply a false color to distinguish between relatively hot and cold surfaces. The FLIR images were captured at the initial startup of the generator and then after 10 minutes of steady state operation. Using the FLIR images, the source of the highest thermal energy came from the exhaust area of the generator. From initial startup, the heat map shows approximately 179°C at the exhaust tip as seen in Figure 2.

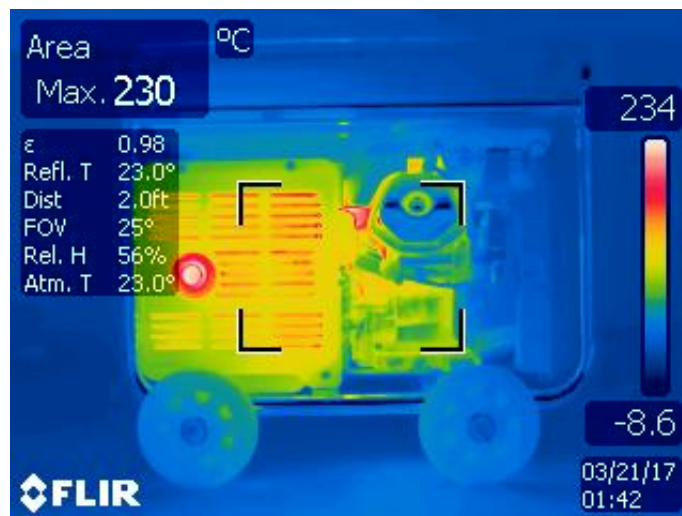

Figure 2. Generator FLIR map at steady state

After 10 minutes, the heat map shows approximately 234°C at the exposed exhaust tip. The rest of the exhaust is enclosed by a heat shield, though there are ventilation slits where the temperature shows near the 234°C indication. The test matrix for characterizing TEG performance consisted of collecting data at 10°C intervals within the range of the exhaust temperatures, starting from 180°C to 250°C. This range would capture any unseen fluctuations from the generator heat map analysis.

To characterize a commercial TEG, an experimental setup was built to control the heat source and provide a constant cooling source as seen in Figure 3. The cooling source was a recirculating chiller that flowed chilled water through a water-cooling block attached to the TEG. This provided a constant cooling source for this research.

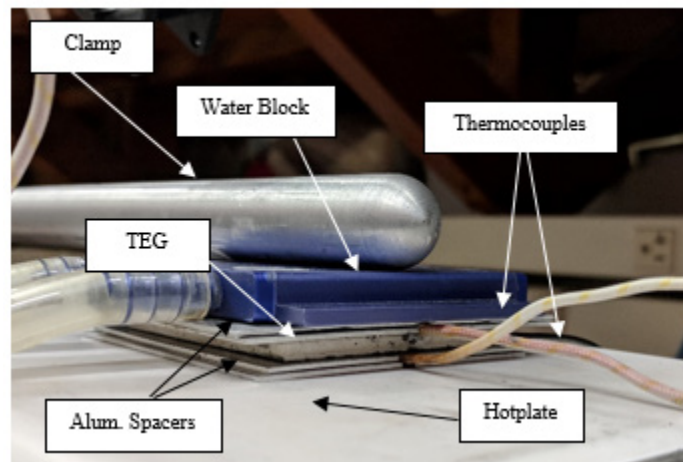

Figure 3. Experimental apparatus of characterization

The data collected for the characterization were the TEG current, TEG voltage, the “hot” side temperature, and the “cold” side temperature. A Vernier-branded energy collection module, two Vernier-branded thermocouples, and Vernier-branded data acquisition modules collected the raw data that were plotted on a spreadsheet. Each of the data collection parameters were collected at 1 second intervals.

The thermal source was controlled by a digital hotplate that operated in Celsius. The optimal running time for each 10°C increment was found to be 600 seconds. The first 200 seconds show how the temperature increases to the set temperature of the hotplate.

This gives approximately 400 seconds for the system to stay in steady state operation. With each data point recorded each second by the data acquisition modules, this gives 400 data points for each temperature increment.

To measure the temperature on the “hot” and “cold” sides of the TEG, a thermocouple was placed against the top and bottom of the TEG. To ensure even thermal conductivity, aluminum spacers were inserted with cutouts for the thermocouples. Thermally conductive paste was used to fill any additional gaps between the thermocouples and the aluminum spacers. The TEG was then sandwiched between the aluminum spacers, the hot plate, and the water-cooling block with a weight to keep the composite together.

To mimic an electrical load, three different resistors were used in increasing magnitude. For this characterization, 1, 10, and 100  $\Omega$  were used. Having three different resistors allowed variances to show in the three data sets. With three different resistors, three sets of runs were done, from 180°C to 250°C in 10°C increments. With 10°C increments, each of the sets would have eight increment sets. Table 1 lays out the test matrix for characterization.

Table 1. Testing matrix

Run 1	Run 2	Run 3
1 $\Omega$	10 $\Omega$	100 $\Omega$
180°C	180°C	180°C
190°C	190°C	190°C
200°C	200°C	200°C
210°C	210°C	210°C
220°C	220°C	220°C
230°C	230°C	230°C
240°C	240°C	240°C
250°C	250°C	250°C

#### D. CHARACTERIZATION DATA AND ANALYSIS

Figure 4 displays the data collected after the experimental characterization. The data revealed a linear relationship between the current and the temperature difference for each resistor. This data agrees with the thermoelectric theory in eq.1 that the commercial TEGs behave normally. At zero temperature difference, the data shows a relative zero current available.

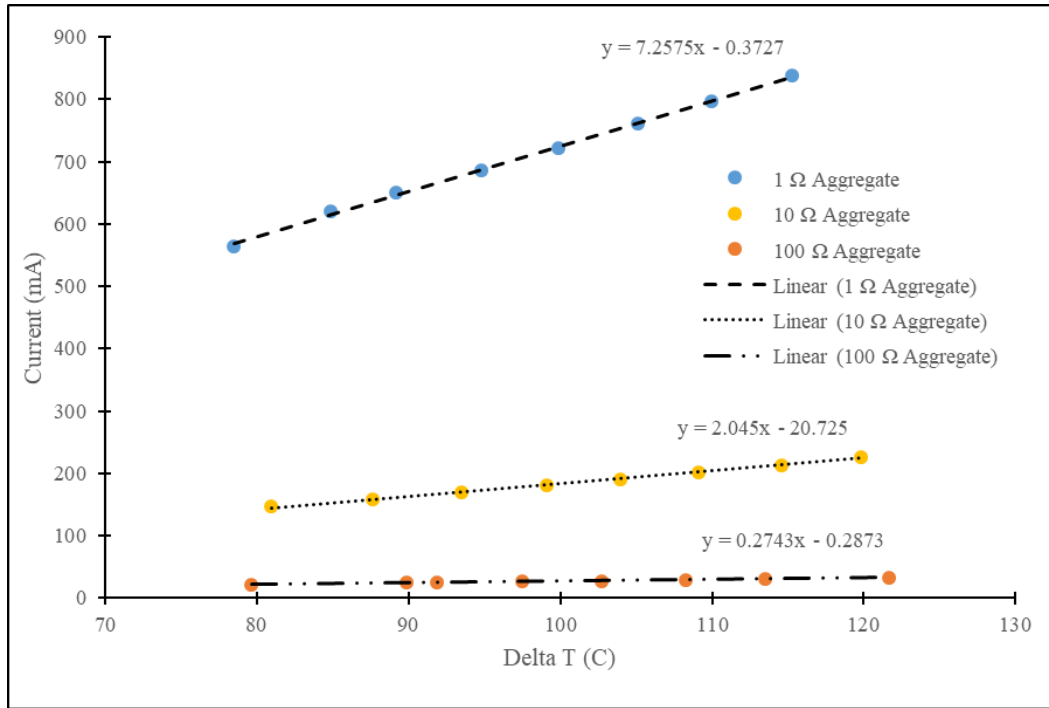

Figure 4. Plot of current against the temperature differential for each resistor used

Using the highest temperature difference for the 1 Ohm load resistor, the module outputs approximately 837 mA and 0.86 V. Using Ohm's Law, the best result is a power output of 0.72W with the load resistor at 1 Ohm and at the largest temperature difference, as seen in Table 2. In order to gain a reasonable power output with these modules, multiple modules need to be assembled in series and in parallel.

Table 2. Summary of characterization results at maximum temperature difference

Load Resistor ( $\Omega$ )	Temp Diff. ( $^{\circ}\text{C}$ )	Current (mA)	Potential (V)	Power (W)
1 $\Omega$	115.26	837.35	0.86	0.72
10 $\Omega$	119.84	225.79	2.14	0.48
100 $\Omega$	121.67	33.31	2.92	0.10

To check for the accuracy of the models displayed in Figure 3, a regression analysis was conducted on the highest temperature difference. Eq. 4 provided the calculations for  $S_e$  and eq. 5 provided the calculations for the confidence intervals (CI Low and High). Table 3 provides a summary of the analysis.

Table 3. Summary of regression analysis

	1-ohm	10-ohm	100-ohm
Temp Diff ( $^{\circ}\text{C}$ )	115	119	121
$S_e$	3.2	3.2	0.15
CI Low (mA)	829.2	214.6	32.6
CI High (mA)	839.2	224.1	22.1

From the analysis, the model was determined to be accurate to the data produced Table 2. Although there is a relative difference in standard error between the 1/10  $\Omega$  and the 100  $\Omega$ , the error is still minimal. The confidence intervals are also small with the intervals approximating 10 mA.

## E. MODELING AND SCALED APPLICATION

Characterization data were programmed into COMSOL, a finite element modeling simulation. To simplify the model, only thermal flow aspects were considered. The temperature from the hot side and the cold side were matched to the data collected through multiple temperature differences. Once an accurate model was built, the module was scaled into an array of different designs.

Observing the initial results in Figure 4 revealed that there was a slight thermal gradient between the edge and the center of the module. As minimal as the gradient is, it showed that some thermal energy escaped through the sides of the TEG. When multiple TEGs are assembled together in an array and there is a gap between them, this gradient will appear on each module as thermal energy is released through the sides of the modules. In contrast, when multiple TEGs are tightly placed together such that the gap is indiscernible between them, then the gradient would only appear at the edges of the array. Table 4 shows the average TEG hot side temperatures between 1, 4, 6, and 9 TEG arrays. Building arrays to this specification would allow the maximum amount of thermal energy to be absorbed by the array.

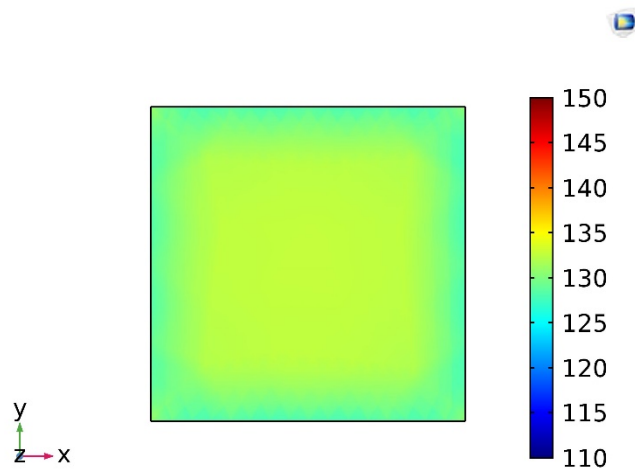

Figure 5. Thermal gradient at the edge of a single TEG module

Table 4. Average hot side temperature of differently arrayed TEGs

	1 TEG	4 TEGs	6 TEGs	9 TEGs
Avg. Temp (°C)	133.55	143.77	144.17	144.32

Using 10 modules as a base design point, 8.6 V could be drawn or 8373 mA. To maintain both electrical parameters, 100 modules are needed; 10 modules in a series set mated to 10 sets in parallel would yield 72W of power. Each module measures approximately 56 mm ± 5 and when 100 are combined in a square format produces a 560 mm by 560 mm or approximately 2 ft. by 2 ft. area that needs to be applied to a thermal source. Applying this to military systems such as field generators or large engines such as those in Figure 5 may not pose much of an issue. For civilian applications, this technology could be applied to enterprise servers, fossil-fueled power plants, or a building’s HVAC system, to name a few. However, smaller systems could find the application of TEGs to be infeasible.



Figure 6. An army generator on the left (US Army 2012) and a naval turbine on the right (Stewart 2016)

Additionally, an interesting concept is born from the production of 72W of power from 100 modules. If it is assumed for the sake of analysis that the TEG is absorbing or passing through all of the thermal energy from the heat source and that none of the energy is dissipated through convection or radiation, then the 72W of power could be reasonably assumed to have been taken away from the thermal source. This could mean a reduction in

IR signature and in the military application makes systems more survivable by reducing an emitted signature.

Taking one module and using its power output of 0.72W, a comparison can be made between that power output and the total energy dissipated by the system. If it is assumed that all the thermal energy is released perfectly from a 1 mm, 56 mm by 56 mm steel plate to the TEG, then the specific heat output can be calculated. Using eq. 2 and the constants for a carbon steel plate, which is  $m = 0.024618$  kg using a density of  $7.850 \times 10^{-6}$  kg/mm<sup>3</sup>,  $C = 0.12$  kcal/(kg °C), and a  $\Delta T$  of 115°C as determined by the 1  $\Omega$  data point at maximum temperature difference, the  $Q$  calculated equates to 0.3397 kcal. Over the span of 600 seconds, as done in the characterization tests, this equates to  $5.66 \times 10^{-4}$  kcal/sec. Converting kcal/sec to watts gave 2.37W of power emitted from the surface. The TEG module would roughly reduce the IR signature or energy by 30%.

## **F. FUTURE WORK**

Future work in this field would include investigating the true reduction in IR energy and exploring how efficient a commercial TEG could perform given a set of conditions. The percentage given here through back-of-the-envelope calculations could be used as a starting point. This concept in IR reduction through TEGs would be very useful if applied to military systems.

Additional work could be done in the realm of pursuing new materials to improve the ZT factor of TEGs. This improvement could advance wide spread use of TEGs in different systems. Their small conversion efficiencies and relatively minimal power output from individual modules preclude their use in mainstream systems design. Increasing their efficiencies and power output could extend the usefulness of systems that produce a great amount of heat in their operation.

Finally, TEG array design could be furthered, as the way modules are built together would affect the overall efficiency of the design. Current TEGs are flat modules that do not flex. Flexible materials or even designing and optimizing the shape and structure of TEGs could efficiently transfer all of the thermal energy from the system for conversion.

This, however, would only be one piece of the overall application, as the module would still need to be efficient enough to convert the thermal energy into useful electrical energy.

## **G. CONCLUSION**

In terms of absolute efficiency, TEGs could prove as a useful source of energy recovery. Although the energy recovered is not largely significant, it is one step forward to recovering usable energy in a system where there is a large thermal source produced. Currently,  $\text{Be}_2\text{Te}_3$  type TEGs are the most widely available modules on the market. However, there are additional TEG compositions that utilize a composite of other materials to improve the efficiency of the TEG. In the case of this research, the commercial TEG used can reach a theoretical temperature output of  $300^\circ\text{C}$  and produce 22W of power. Under characterization testing, a temperature difference of  $115^\circ\text{C}$  produced only 0.72W. Applied to large systems, an array of 100 modules can provide 72W of power with modules built in series and in parallel. This could be feasible for the amount of energy recovered, as this output would be enough to light five 100W equivalent LED light bulbs.

If this technology is developed further to improve the efficiency of the modules, an application to all heat producing systems could prove worthwhile. Currently, it may not be feasible to implement it, but it can provide a passive source of increasing system efficiency.

Continuing to test TEGs on military applications is still a viable option, as not only is energy recovery possible, but a reduction in IR signature could also be applied with the use of TEGs. Reducing IR signatures would greatly enhance the survivability of a military system, which is a performance parameter not necessarily designed for civilian systems. If the enemy is unable to detect friendly systems on the battlefield, it would provide a combat advantage to the troops who use that system. At that point, the energy harvested could change into a secondary goal when using TEGs on military systems. A rough calculation provided a 30% reduction in thermal energy, which is significant enough. However, additional research is needed to truly understand the total decrease in thermal energy from TEGs.

THIS PAGE INTENTIONALLY LEFT BLANK

### III. PAPER II: USING MODELING AND SIMULATIONS TO CHARACTERIZE TEG ARRAYS

This chapter was previously published as: Moreno, Rondolf, Dragoslav Grbovic, and Anthony Pollman. 2019. "Using Modeling and Simulations to Characterize TEG Arrays." In *Proceedings of the International Conference of Innovative Applied Energy 2019 1* (IAPE2019): 1–5., Oxford, UK. [http://iape-conference.org/Downloads/Proceedings/Articles%20\(Abstracts%20&%20Papers\)/a-1-Article-051.pdf](http://iape-conference.org/Downloads/Proceedings/Articles%20(Abstracts%20&%20Papers)/a-1-Article-051.pdf). Re-print permission was granted by IAPE on March 15, 2019. Copyright does not apply in the United States but does apply internationally.

#### A. ABSTRACT

Modeling and simulation are key concepts in systems engineering and system design. They allow the engineer to use fewer resources to establish a sound design before fully committing to building a full prototype. Using this concept, this paper goes through the modeling process for the application of thermoelectric generators (TEG) in an array. Systems could benefit off using this passive thermal recovery device by converting that thermal energy into electricity. For military systems, this is beneficial as there are many initiatives in the United States military to reduce their reliance on fossil fuels by making current systems more efficient or converting to systems that do not use fossil fuels. Applying TEGs to these particular systems would help with this initiative and possibly have an intrinsic benefit of reducing a system's thermal signature, which could be a topic of future work. Designing the models and simulation for this application needs to be basic and simple before creating complex models for final design. The types of models built and discussed in this paper will help form the basis of design of an array. These models would help determine the amount of TEGs needed to meet a requirement of the system.

*Keywords: Modeling, simulation, thermoelectric generator, PSPICE, systems engineering, energy harvesting, energy conversion, heat transfer, heat recovery, thermal power, modeling, Seebeck effect*

## **B. INTRODUCTION**

Modeling design is an important concept in the field of engineering. It provides a rapid and low cost option to understand system dynamics for the engineer, before any physical prototyping is done. With established models, an engineer could adjust system designs relatively quickly to meet system requirements. Furthermore, the systems engineer would need to understand how detailed a model and simulation should be in order to analyze the system itself. Modeling and simulation could take many hours of labor to establish and run. However, a model and simulation with less fidelity and detail could still achieve the required responses needed to decide on an initial design.

This paper researched the Thevenin equivalent properties of a thermoelectric generator (TEG) for modeling in a PSPICE simulation. The model built several array designs and provided a foundation in which to build to a specific application. Verification of the model is done through regression analysis against the data acquired from the characterization experiments.

## **C. BACKGROUND**

The Department of Defense (DoD) is exploring methods and system designs that reduce reliance on fossil fuels (HDIAC 2015). This era of efficiency and energy security created initiatives within the branches of the military that follow the DoD's vision of energy use in the military, which span from the Army's "breaking the tether of fuel" (Douquet 2017) to the Navy's "Great Green Fleet" (Orchard-Hays and King 2017). The Marine Corps presented ideas that follow this movement earlier in the century, with an article on optimizing energy use that increased the capabilities of Marines on the battlefield (Pollman 1997).

One form of energy optimization is the recovery of thermal heat in systems. Although there are many forms of recovering heat energy from systems, especially in power generation (US Department of Energy 2017), one particular form of waste heat recovery provides a passive method of converting heat energy to electricity. That form is thermoelectric generation and it uses the Seebeck effect to produce electricity from a temperature difference. TEGs use two dissimilar metals where one is doped with positive

charge carriers and the other is doped with negative charge carriers. When connected electrically in series and thermally in parallel, the Seebeck effect would apply (Aimable 2017).

TEGs are a passive form of recovery waste heat. They do not rely on moving parts and they do not produce anything other than electricity (Dziurdzia 2011). This form of recovery is ideal, as the only design requirement to apply TEGs is the minimal space it requires, which could be as thin as 40  $\mu\text{m}$  (We, Kim and Cho 2014), and a cooling source, which could be as simple as the surrounding environment (Thomas 2015). These characteristics are ideal in application to a wide variety of systems.

This paper builds off a previous paper that established characterization data for a commercial-off-the-shelf (COTS) thermoelectric generator (TEG). That paper used COMSOL to provide the thermal model in which to analyze the temperature difference of a given design on a system (Moreno, Pollman and Grbovic 2018). Additionally, it gave specific back-of-the-envelope calculations that generalized the output of a TEG array based off basic electrical calculations. An interesting concept bore out of that paper, in that the converted thermal energy would theoretically be a reduction in the system's infrared signature. With a robust electrical model, specific instances of produced electrical energy could be used to compare the heat losses in the system.

## **1. Modeling in the Systems Engineering Process**

Within the systems engineering process, modeling and simulation play an important role in establishing the right system for the requirements needed. The advantage of any modeling and simulation is the reduction in time and money working toward constructing that right system.

Often, building the actual system is costly and infeasible (Law 2015). Thus, using models and simulations help with focusing efforts into deciding the right characteristics of the system before any physical prototypes are constructed. However, these models should answer a question or set of questions to be effective. Without this direction, models could become too complicated for the objective or give an answer where it becomes harder to obtain the insight to why that answer is so (Buede 2008). Occam's razor also provided

principles that apply to modeling and engineering: “when you have two competing theories that make exactly the same predictions, the simpler one is the better” (Chase, et al. 1992).

## 2. Thevenin Equivalent Resistance

An important concept in analyzing complex circuits is Thevenin’s Theorem. Since a TEG involves a significant amount of P and N semiconductors joined electrically in series, each component contributes to the overall circuit of the TEG. Using Thevenin’s Theorem, the aggregate of the entire TEG can be reduced to a singular internal resistance and voltage source. Equation 1 shows the mathematical relationship used to calculate the aggregate internal resistance of a TEG module (Sheikholeslami 2018).

$$v_{load} = v_{oc} - i_{load}R_{eq} \quad (6)$$

## 3. Regression Analysis

When constructing a model, it is important to understand how accurate it follows the experimental data or the phenomenon that is being modeled. Using sum squared error coupled with sum squared total allows for an R-squared calculation that reveals how well the model fits the data.

Sum squared error is defined to be the following (Hayter 2012):

$$SSE = \sum_{i=1}^n (y_i - \hat{y}_i)^2 \quad (7)$$

where  $y_i$  is  $i$ th data point and  $\hat{y}_i$  is the  $i$ th modeled response. Total sum of squares is defined to be the following (Hayter 2012):

$$SST = \sum_{i=1}^n (y_i - \bar{y})^2 \quad (8)$$

where  $\bar{y}$  is the mean of all the data points. Together, they produce the R-squared value, as defined by (Hayter 2012):

$$R^2 = 1 - \frac{SSE}{SST} \quad (9)$$

R-squared is not necessarily a definitive tool for understanding models that “best-fit” the response from a system; however, it does give an understanding that the model is “good enough” for a particular application. For use on engineering applications, especially for quick design and prototyping, this method created quick calculations and multiple designs that can rule out outlying systems that will not meet specifications.

#### D. OPEN CIRCUIT CHARACTERIZATION

In order to model a TEG, the internal resistance is needed. An experimental setup provided the ability to measure its internal resistance. A TEG is sandwiched between a hotplate as a heat source and a water-cooling block. Then, spacers allow for the use of thermocouples to measure the temperature in the cold and hot side of the TEG. Finally, a clamp holds the system together. Using this experimental setup as seen in Figure 6, a multi-meter measured the voltage and current of the TEG through various ranges of temperature differences. The TEG used three specific resistive loads for each set of temperature ranges. Using the Thevenin’s Theorem, the data set enabled the calculation of the TEG’s internal resistance.

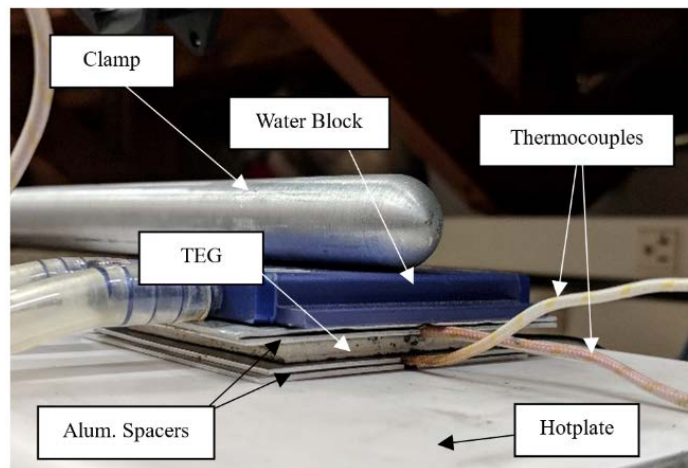

Figure 7. Setup of experimental characterization system (Moreno, Pollman, and Grbovic 2018).

Temperature bounded the experimental characterization. The range of temperatures needed for the hot source mimics that found on a petrol generator. The typical temperature

range found was from 180°C to 250°C. This is used in the test matrix to characterize the internal resistance of the TEG in 10°C increments. At each temperature increment, the multi-meter collected the data in five runs. Each run alternated the resistive load as well, from 1 ohm, to 2.5 ohm, to 10 ohms, and back to 1 ohm in order to check for any hysteresis or discrepancies in the data given by the setup.

For each resistive load and temperature increment, the voltage is measured when the TEG is in an open state (open circuit), the voltage when the resistive load is applied, and the current when the resistive load is applied. Also measured is the temperature of the hot side and the cold side, to associate the temperature difference between the two sides. The results of the measurements can be found in Appendix A.

## E. MODELING AND SIMULATION

A spreadsheet program organized the data and provided regression models for each resistive load data set. The regression data for each set provided a mathematical model of the Thevenin equivalent resistance. Equations 10, 11, and 12 are the models for the internal equivalent resistance for 1-ohm, 2.5-ohm, and 10-ohm respectively.

$$R_{eq} = 0.0134T_{diff} + 2.3677 \quad (10)$$

$$R_{eq} = 0.0108T_{diff} + 2.5426 \quad (11)$$

$$R_{eq} = 0.0107T_{diff} + 2.34 \quad (12)$$

Each model has relatively small differences among their elements. To account for all of these differences, the final model averaged out the slopes and the intercepts respectively, as shown by equation 13.

$$R_{eq} = 0.0116T_{diff} + 2.417 \quad (13)$$

Additionally, the voltages given by the circuit in an open state also provided slightly differing models for each of the resistive loads. Equations 14, 15, and 16 shows each of the differences for 1-ohm, 2.5-ohm, and 10-ohm respectively.

$$V_{oc} = 0.0321T_{diff} - 0.8159 \quad (14)$$

$$V_{oc} = 0.0319T_{diff} - 0.8001 \quad (15)$$

$$V_{oc} = 0.0312T_{diff} - 0.7368 \quad (16)$$

Again, to account for these differences, the final model averaged out all the elements, shown by equation 17.

$$V_{oc} = 0.0317T_{diff} - 0.78427 \quad (17)$$

PSPICE software established the base model of a TEG in order to create simulation profiles of different arrays. Once one module is created, it is scaled to a pair created in a parallel circuit and one in a series circuit. The focus of the model is to provide an accurate enough representation of one module in order to scale to a determinant size based off a requirement.

Since TEGs are based off a temperature difference, the parameters function in PSPICE provided the means to change values in the circuit based on the temperature difference specified. The voltage source and internal resistance PSPICE components used the mathematical models designed in the spreadsheet program and uses that temperature difference specified under Parameters. Figure 7 shows the graphical model of a singular module with a resistive load and the Parameters list in PSPICE. As with the open circuit characterization, the simulation ran in three sets, based off the resistive loads. In the simulation profile, a sweep programmed in PSPICE allowed the model to run through a range of temperature differences that output voltage, current, and power.

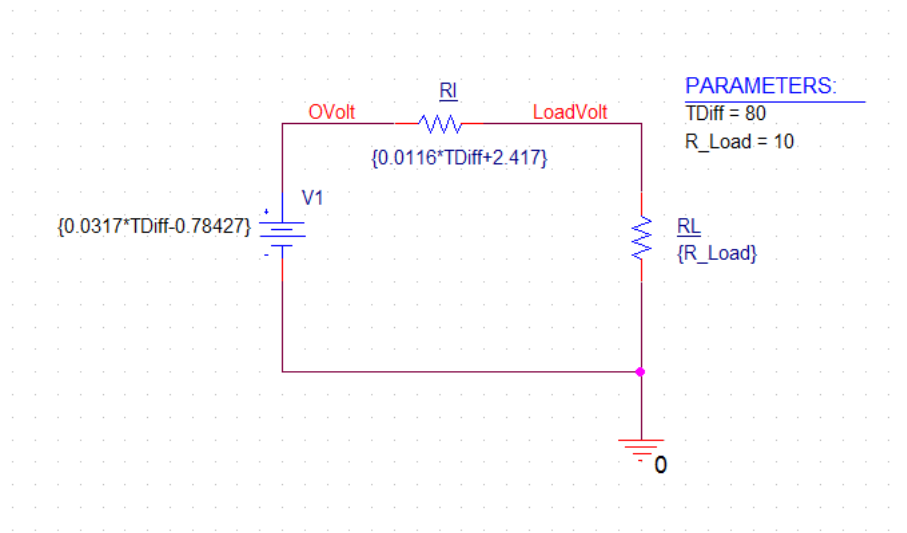

Figure 8. Layout of a single TEG module in PSPICE.

## F. ANALYSIS OF MODELS

For each resistive load, the PSPICE model provided a set of values for validation against the measured data. The values used from the model were the equivalent circuit and the resistive load voltages. These values created a mathematical model that allowed a comparison between the measured data and the values produced by PSPICE. For each measured temperature difference, the PSPICE derived model calculated the corresponding value that pairs with the measured value. This is done through the range of temperature differences, once for each of the resistive loads. Equation 2 and equation 3 respectively calculated SSE and SST for each of the compared values, equivalent circuit and resistive load voltages. Equation 4 then calculated the R-squared value for the model produce in SPICE. Table 5 summarizes the R-squared values for equivalent circuit and resistive load voltages under each resistive load.

Table 5. Summary of R-squared values

<b>1-ohm</b>		<b>2.5-ohm</b>		<b>10-ohm</b>	
$V_{oc}$	$V_{load}$	$V_{oc}$	$V_{load}$	$V_{oc}$	$V_{load}$
0.9594	0.3313	0.9609	0.9560	0.9597	0.9010

The regression analysis showed how accurately the PSPICE model fits the measured data. All of the models, except for one, exhibited a R-squared value greater than 90%. The only model that did not exhibit a good fit was the resistive load voltage for a load of 1 ohm. That model exhibited a 33% R-squared value. Observing the values showed that with a 2.5-ohm resistance, the R-squared value was the highest. This is indicative that the match resistance of the circuit is closer to 2.5-ohm. Figures 8 and 9 show the graphical output of the PSPICE model overlaid on the data for the voltage at the resistive load and the equivalent circuit voltage.

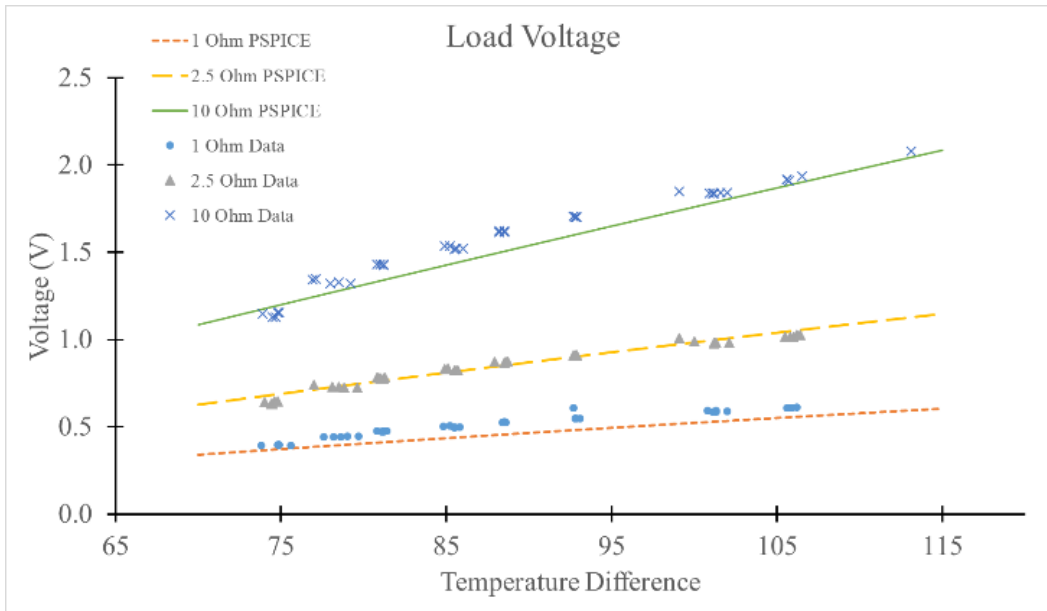

Figure 9. PSPICE model overlay on the data for voltage found at the resistive load

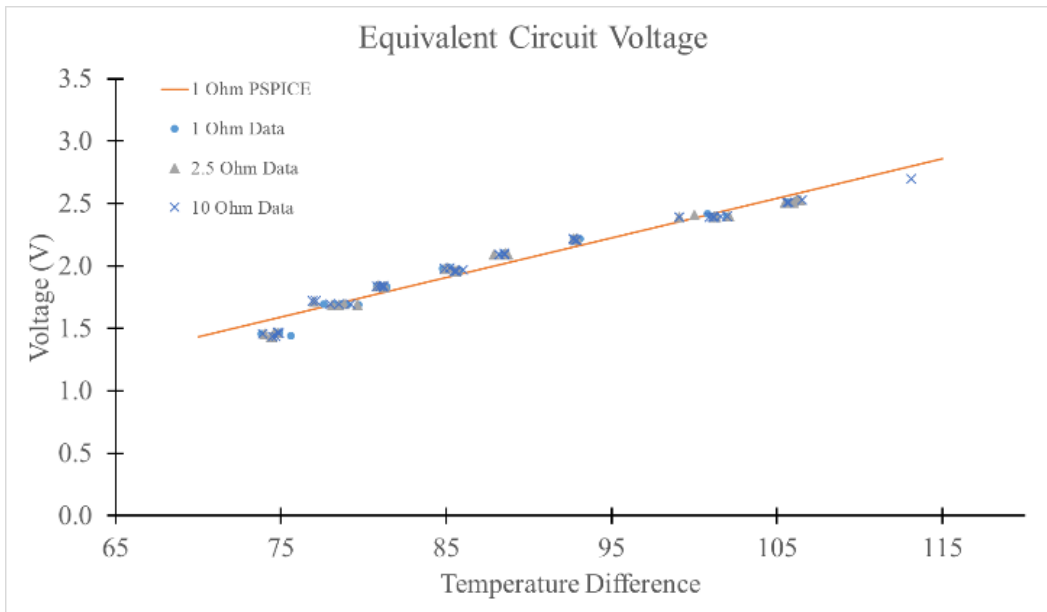

Figure 10. PSPICE model overlay on the data for voltage in the equivalent circuit

**G. MODELING AND SIMULATING ARRAYS**

The model for a singular TEG created the foundation to scale to different sized arrays. The model placed modules in series and scaled the array into two, four, and eight modules. The model also placed the modules in parallel and the same scaling process is done. PSPICE’s sweep function analyzed the voltage, current, and power from each of the TEG arrays produced. A summary of the simulation results for the maximum temperature difference shown in the following table:

Table 6. Power (W) at 115°C temp. diff.

<b>Parallel Arrangement</b>			
	2 Modules	4 Modules	8 Modules
1-ohm	1.0732	2.1803	3.7943
2.5-ohm	0.9960	1.7318	2.3220
10-ohm	0.5813	0.6843	0.7470
<b>Series Arrangement</b>			
	2 Modules	4 Modules	8 Modules
1-ohm	0.4567	0.5114	0.5449
2.5-ohm	0.8239	1.0688	1.2395
10-ohm	1.0732	2.0951	3.2733

The data provided by PSPICE can be used to produce curves that determine the power output based on the number of modules in an array. Using the 2.5-ohm data as an example, these curves shown graphically in Figures 10 and 11.

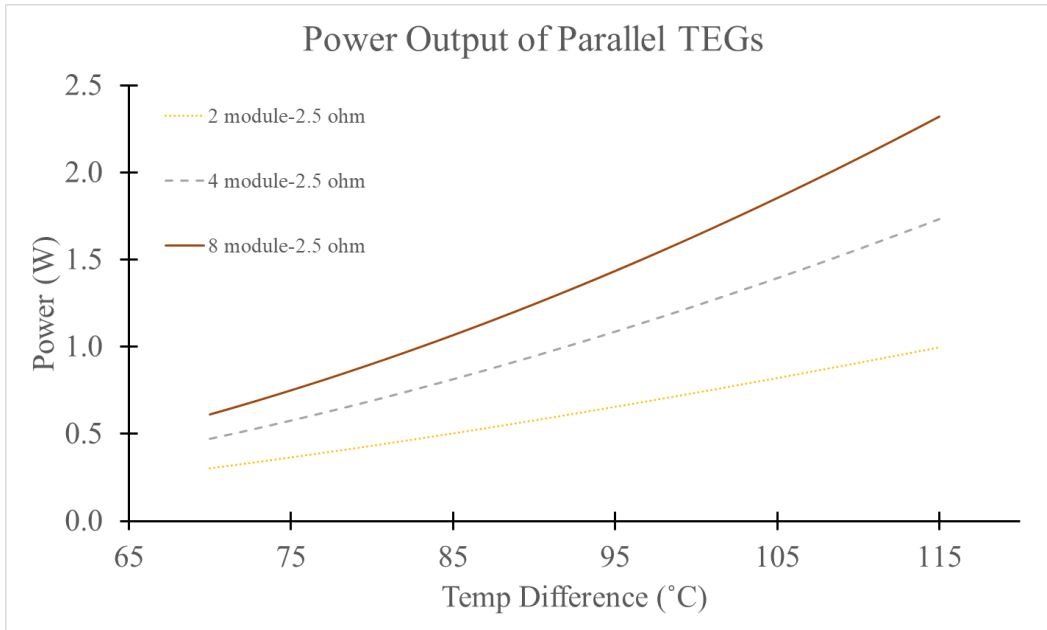

Figure 11. Power output curves for parallel-attached TEGs

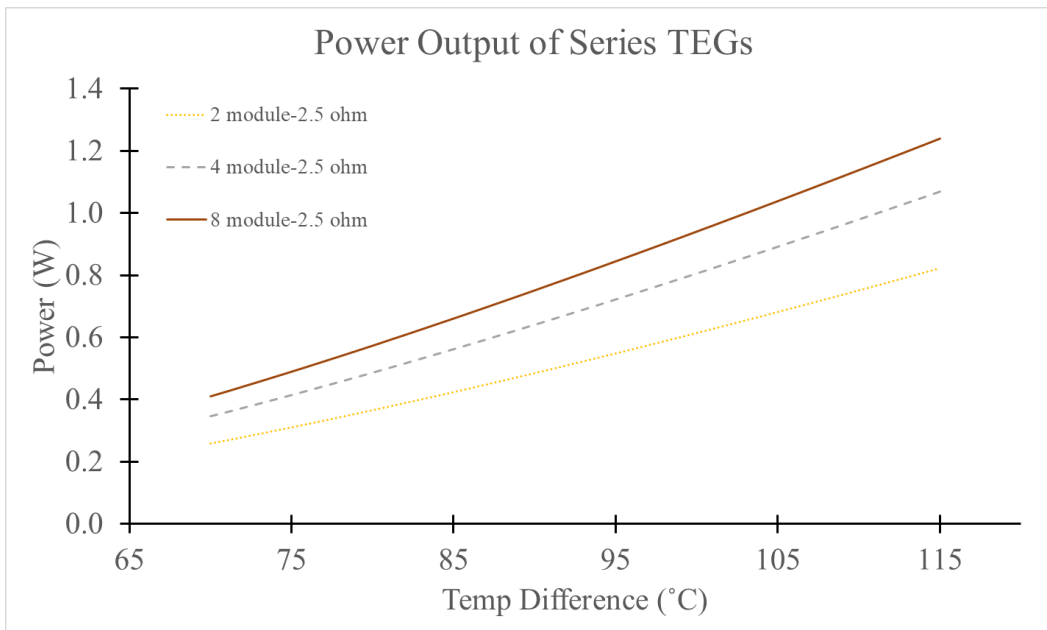

Figure 12. Power output curves for series-attached TEGs

As they are, these curves do not give an insight to the type of power output for different designs. However, using this data transformed into a different method would give an engineer or designer the ability to understand how an array design would affect the power output of the system. Re-organizing the data gave the follow two Figures for the 2.5-ohm data.

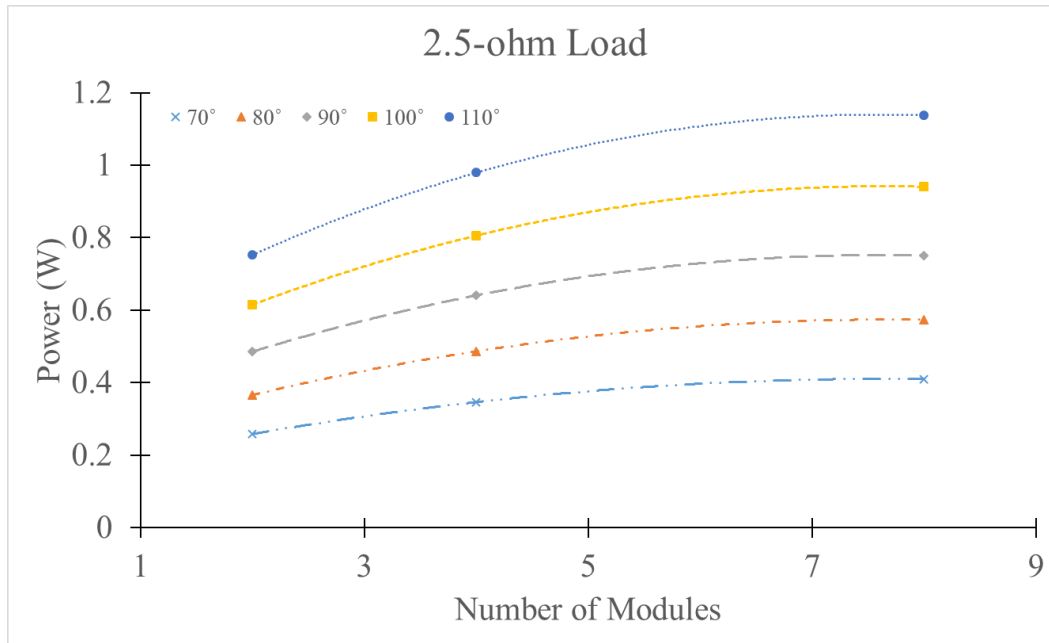

Figure 13. Power output curves for parallel-attached TEGs based on the number of modules.

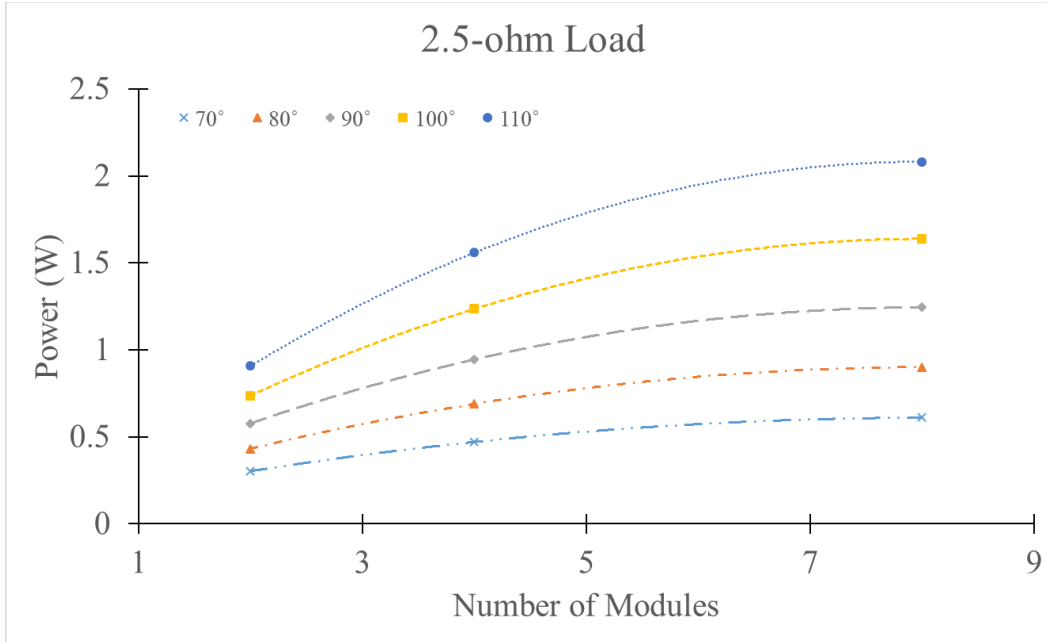

Figure 14. Power output curves for series-attached TEGs based on the number of modules.

With each curve now representing a target temperature difference, an engineer can find the best number of modules to build the array for the required power output. Each target temperature within the range of data provides more than one design consideration for the array.

## H. FUTURE WORK

With the foundation of modeling and simulation done in this paper, arrays can be designed and built according to a specific requirement. The design would guide the building of a prototype to enable a proof-of-concept system to reveal the applicability of a TEG array. Further work would include using this process to build a physical prototype of a system implemented on a generator as a proof-of-concept design. This prototype would be ideal in verifying the models designed in this paper.

A novel concept from a previous paper involved the idea that when a TEG harvests thermal energy from the attached system to convert into electricity, that process reduced the system's thermal signature. Using the modeling concepts from this paper could help further research for that concept. Understanding how thermal signatures are affected by

this type of system could prove useful for systems that require a reduction in thermal signatures. This is especially true in military systems, where thermal signatures could reveal systems to enemy forces using thermal sensors as seen in Figure 14. There is current research in using covers to conceal thermal signatures, but would theoretically be at the expense of increased thermal concentrations in the system. This technology would instead remove that thermal energy, keeping the system cooler than with a thermal cover. Additionally, reducing thermal energy could assist in making systems safer, through reducing burn injuries or reducing the severity of burns through accidental contact with the system.

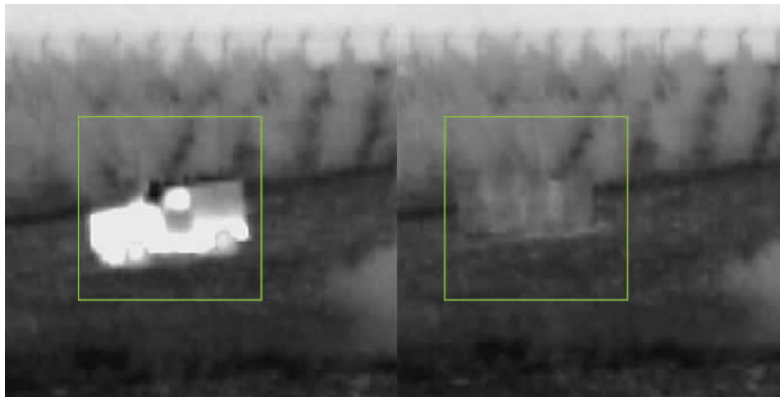

Figure 15. Image that displays the use of camouflaging thermal signatures (Eshel 2011).

## I. CONCLUSION

Modeling and simulation is an important aspect of developing systems. This paper explored the use of modeling and simulation to understand the electrical output of applying a TEG array to a system. Using the concepts and information from a previous work, PSPICE produced data that built mathematical models. Those models were tradeoff curves that would allow an engineer or a designer to build a TEG array design that best suited a requirement.

This paper also explored the use of models that fit the application. It explored the mantra that “less is more” when applied to modeling and showed that basic models are all

that's needed to make initial design and engineering decisions. Although there is validity in complex models, basic models drive the system design early in the design process without spending excess time, labor, and money. This paper answers question about the system early and could help scope design characteristics for engineers.

THIS PAGE INTENTIONALLY LEFT BLANK

## IV. CONCLUSION

TEGs could be a practical technology that can be used in systems today. In particular, with the DoD creating energy initiatives for more efficient systems and policies, TEGs could be a natural fit into future military systems. Using the systems engineering process and building high-level models to inform design allows engineers and acquisition officers could make informed decisions about how TEGs could fit in current and future systems.

This research effectively characterized current commercial TEGs and their output and provided the ability to produce high-level models for other TEGs. Commercial TEGs may or may not be the best application for systems, however, there are industrial modules that could better fit systems that produce a large amount of thermal energy. The processes explained here would help with the analysis of applying such modules. By aligning with the principles in systems engineering, technology readiness level of particular TEGs could be easily applied with relatively low effort. Keeping modeling and simulations simple in the definition and decomposition phase in the “vee” model allows more time to realize an optimum solution or design for a system.

Although the efficiency of TEGs is relatively low, they still provide the benefit of transforming thermal energy into electricity in a passive, low impact manner. They could service a particular functional requirement that may not be realized with other technologies. Furthermore, their ability to transform thermal energy into electricity could provide an additional benefit of masking a system’s thermal signature. This function alone could be sought after for systems requiring stealth with a low impact on design.

The techniques in model building and simulation discussed here could be tested against a physical prototype design. Models created after a design would serve as the basis for building a physical prototype. Comparing the physical resultant output with the data established in the model and simulation would verify the model produces the appropriate responses based off the inputs established. Verifying that the model is appropriate would lead to other designs built to meet a specific established requirement, such as powering a

light bulb or charging a mobile device. Iterative designs built by the modeling program ensure that several options are explored to meet an optimal design that can be validated against the requirements.

After consideration of the data, modeling, and design analysis outputs in this research, TEGs could feasibly work with military systems. They do provide an additional source of energy from heat producing systems with relatively low impact on design. However, for greater understanding on the design impacts of adding this type of technology, physical prototypes would allow for verification of the models that the second conference paper produced. This would provide a thorough understanding of the output that the modules produced when scaled. Additionally, a physical prototype would provide insight in the reality of physically applying this technology. The experimentation and modeling conducted in this research only establishes the foundation of the study in which to move forward.

Further study into the thermal effects of the modules would also be a crucial focus point for military systems. In a time where near-peer competitors are producing advanced sensors for themselves, masking the signatures of military systems could provide the edge against the enemy. If not a secondary priority, TEG technology could primarily assist in thermal signature reduction. This aspect of the technology would need further research to understand its effects in theory and in reality. The modeling designs and data produced by this research would help to drive that understanding.

## APPENDIX. OPEN CIRCUIT DATA

<b>1 ohm</b>				
<b>Set Temp</b>	<b>Temp Diff</b>	<b>Voc</b>	<b>Vrl</b>	<b>I (A)</b>
180	75.6	1.44	0.391	0.319
180	73.8	1.455	0.394	0.323
180	74.9	1.461	0.396	0.319
180	74.9	1.466	0.398	0.325
180	74.8	1.466	0.397	0.324
190	79.7	1.689	0.444	0.365
190	79	1.691	0.444	0.366
190	78.6	1.693	0.442	0.365
190	78.2	1.691	0.442	0.365
190	77.6	1.693	0.443	0.364
200	81.4	1.833	0.474	0.39
200	81.2	1.835	0.474	0.39
200	81.2	1.836	0.473	0.391
200	81.1	1.84	0.473	0.392
200	80.8	1.837	0.474	0.391
210	85.5	1.955	0.496	0.41
210	85.5	1.961	0.497	0.411
210	85.8	1.963	0.498	0.412
210	84.8	1.979	0.503	0.415
210	85.2	1.986	0.505	0.416
220	88.5	2.09	0.526	0.434
220	88.6	2.09	0.524	0.435
220	88.5	2.1	0.525	0.434
220	88.4	2.09	0.526	0.434
220	88.5	2.1	0.527	0.435
230	93.1	2.22	0.547	0.454
230	92.8	2.22	0.549	0.453
230	92.8	2.21	0.548	0.451
230	92.8	2.21	0.546	0.454
230	92.7	2.22	0.608	0.503
240	100.8	2.42	0.594	0.492
240	102	2.4	0.59	0.487
240	101.3	2.4	0.591	0.486
240	101.3	2.39	0.587	0.488
240	101.1	2.39	0.587	0.487

<b>1 ohm</b>				
<b>250</b>	105.9	2.51	0.607	0.503
<b>250</b>	105.9	2.51	0.607	0.505
<b>250</b>	105.7	2.51	0.607	0.505
<b>250</b>	105.6	2.51	0.607	0.505
<b>250</b>	106.2	2.53	0.613	0.509

<b>2.5 ohm</b>				
<b>Set Temp</b>	<b>Temp Diff</b>	<b>Voc</b>	<b>Vrl</b>	<b>I (A)</b>
<b>180</b>	74.5	1.433	0.631	0.251
<b>180</b>	74.4	1.431	0.629	0.249
<b>180</b>	74	1.455	0.641	0.256
<b>180</b>	74.8	1.463	0.646	0.256
<b>180</b>	74.6	1.466	0.647	0.257
<b>190</b>	79.6	1.691	0.726	0.289
<b>190</b>	78.8	1.693	0.726	0.289
<b>190</b>	78.5	1.691	0.727	0.289
<b>190</b>	78.1	1.691	0.728	0.289
<b>190</b>	77	1.718	0.741	0.293
<b>200</b>	81.2	1.83	0.777	0.31
<b>200</b>	81.3	1.839	0.78	0.31
<b>200</b>	81	1.839	0.779	0.311
<b>200</b>	80.9	1.843	0.78	0.31
<b>200</b>	80.8	1.839	0.78	0.311
<b>210</b>	85.5	1.958	0.821	0.327
<b>210</b>	85.6	1.961	0.822	0.328
<b>210</b>	85.7	1.965	0.824	0.328
<b>210</b>	84.9	1.977	0.831	0.331
<b>210</b>	85.1	1.985	0.836	0.333
<b>220</b>	88.7	2.09	0.871	0.347
<b>220</b>	88.7	2.09	0.871	0.348
<b>220</b>	88.5	2.09	0.87	0.347
<b>220</b>	87.9	2.09	0.871	0.348
<b>220</b>	88.6	2.1	0.871	0.348
<b>230</b>	92.9	2.22	0.91	0.364
<b>230</b>	92.9	2.22	0.909	0.364
<b>230</b>	92.8	2.21	0.91	0.363
<b>230</b>	92.7	2.22	0.91	0.364
<b>230</b>	99.1	2.39	1.007	0.401

<b>2.5 ohm</b>				
<b>240</b>	100	2.41	0.988	0.393
<b>240</b>	102.1	2.4	0.981	0.39
<b>240</b>	101.3	2.39	0.98	0.39
<b>240</b>	101.2	2.39	0.98	0.392
<b>240</b>	101.2	2.4	0.978	0.39
<b>250</b>	106	2.51	1.014	0.406
<b>250</b>	105.8	2.51	1.016	0.404
<b>250</b>	105.5	2.51	1.015	0.406
<b>250</b>	106.4	2.53	1.025	0.41
<b>250</b>	106.2	2.53	1.025	0.409

<b>10 ohm</b>				
<b>Set Temp</b>	<b>Temp Diff</b>	<b>Voc</b>	<b>Vrl</b>	<b>I (A)</b>
<b>180</b>	74.7	1.439	1.13	0.1
<b>180</b>	74.5	1.436	1.127	0.1
<b>180</b>	73.9	1.456	1.148	0.102
<b>180</b>	74.9	1.465	1.156	0.102
<b>180</b>	74.8	1.466	1.155	0.102
<b>190</b>	79.2	1.694	1.32	0.117
<b>190</b>	76.9	1.721	1.343	0.119
<b>190</b>	78.5	1.695	1.327	0.117
<b>190</b>	78	1.695	1.322	0.117
<b>190</b>	77.1	1.723	1.348	0.119
<b>200</b>	81.2	1.834	1.428	0.126
<b>200</b>	81.2	1.833	1.428	0.126
<b>200</b>	81.2	1.841	1.43	0.127
<b>200</b>	81	1.839	1.429	0.126
<b>200</b>	80.8	1.837	1.432	0.127
<b>210</b>	85.5	1.961	1.516	0.134
<b>210</b>	85.6	1.961	1.519	0.135
<b>210</b>	86	1.968	1.522	0.135
<b>210</b>	85.2	1.984	1.536	0.136
<b>210</b>	84.9	1.98	1.536	0.136
<b>220</b>	88.2	2.09	1.616	0.143
<b>220</b>	88.5	2.1	1.621	0.143
<b>220</b>	88.5	2.09	1.617	0.143
<b>220</b>	88.5	2.1	1.619	0.143
<b>220</b>	88.2	2.09	1.622	0.143

<b>10 ohm</b>				
<b>230</b>	92.7	2.22	1.707	0.151
<b>230</b>	92.9	2.21	1.701	0.15
<b>230</b>	92.8	2.21	1.703	0.151
<b>230</b>	92.7	2.22	1.706	0.151
<b>230</b>	99.1	2.39	1.85	0.165
<b>240</b>	102	2.4	1.84	0.163
<b>240</b>	101.6	2.4	1.841	0.163
<b>240</b>	101.1	2.39	1.836	0.163
<b>240</b>	101.2	2.39	1.837	0.163
<b>240</b>	100.9	2.39	1.839	0.163
<b>250</b>	105.71	2.51	1.91	0.17
<b>250</b>	105.6	2.51	1.918	0.17
<b>250</b>	105.6	2.51	1.918	0.17
<b>250</b>	106.5	2.53	1.935	0.172
<b>250</b>	113.1	2.7	2.08	0.184

## LIST OF REFERENCES

- Aimable, Ngendahayo. 2017. *Design, Modeling, and Fabrication of Thermoelectric Generator for Waste Heat Recovery in Local Process Industry*. Kristiansand: University of Agder.
- Anatychuk, L., V. Mykhailovsky, and L. Strutynska. 2011. "Self-Contained Thermoelectric Generator for Cell Phones." *Journal of Electronic Materials* 40, no. 5 1119–1123.
- Bigger, Patrick, and Neimark, Benjamin D. 2017. "Weaponizing nature: The geopolitical ecology of the U.S. Navy's biofuel program." *Journal of Political Geography* 60 (2017) 13–22.
- Blanchard, Benjamin S., and Wolter J. Fabrycky. 2011. *Systems Engineering and Analysis*. 5th Edition. Boston: Prentice Hall.
- Buede, Dennis M. 2008. *The Engineering Design of Systems*. Hoboken, NJ: John Wiley & Sons, Inc.
- Chase, Scott, Michael Weiss, Philip Gibbs, Chris Hillman, and Nathan Urban. 1992. "What Is Occam's Razor?" University of California, Riverside, Department of Mathematics. Accessed July 30, 2018. <http://math.ucr.edu/home/baez/physics/General/occam.html>.
- Crane, D., and J. LaGrandeur. 2010. "Progress Report on BSST-Led U.S. Department of Energy Automotive Waste Heat Recovery Program." *Journal of Electronic Materials* 39, no. 9.
- Davenport, Bradley P. 2004. "Advanced Thermophotovoltaic Cells Modeling, Optimized for use in Radioisotope Thermoelectric Generators (RTGS) for Mars and Deep Space Missions." Master's Thesis, Naval Postgraduate School. <http://hdl.handle.net/10945/1170>.
- Department of Defense. 2017. *Defense Acquisition Guidebook*. Washington, DC: Department of Defense.
- Department of Transportation. 2007. *Systems Engineering for Intelligent Transportation Systems*. Washington, DC: Department of Transportation.
- Douquet, Greg. 2017. *Army Operational Energy* (blog). January 11, 2017. <http://www.atlanticcouncil.org/blogs/defense-industrialist/unleash-us-from-the-tether-of-fuel>.

- Dziurdzia, Piotr. 2011. "Modeling and Simulation of Thermoelectric Energy Harvesting Processes." In *Sustainable Energy Harvesting Technologies - Past, Present and Future*, 109–128. Rijeka, Croatia: Intech.
- Eshel, Tamir. 2011. "Israeli Company Debut 'Stealth Armor' Making Vehicles 'Disappear.'" *Defense Update*. May 12. Accessed July 24, 2018. [https://defense-update.com/20110512\\_eltics\\_black\\_fox.html](https://defense-update.com/20110512_eltics_black_fox.html).
- Hayter, Anthony. 2012. "Chapter 12: Simple Linear Regression and Correlation." In *Probability and Statistics for Engineers and Scientists Fourth Edition*, 569–570. Boston: Brooks/Cole and Cengage Learning.
- HDIAC. 2015. "Military's Shift Toward Renewable Energy." *Armed with Science* (blog). August 12, 2015. <http://science.DoDlive.mil/2015/08/12/militarys-shift-toward-renewable-energy/>.
- Hutchinson Unabridged Encyclopedia with Atlas and Weather Guide*. 2016. S.v. "Seebeck effect." [http://libproxy.nps.edu/login?qurl=http%3A%2F%2Fsearch.credoreference.com%2Fcontent%2Fentry%2Fheliconhe%2Fseebeck\\_effect%2F0%3FinstitutionId%3D901](http://libproxy.nps.edu/login?qurl=http%3A%2F%2Fsearch.credoreference.com%2Fcontent%2Fentry%2Fheliconhe%2Fseebeck_effect%2F0%3FinstitutionId%3D901).
- Ikoma, K., M. Munekiyo, K. Furuya, M. Kobayashi, T. Izumi, and K. Shinohara. 1998. "Thermoelectric Module and Generator for Gasoline Engine Vehicles." *Proceedings of the IEEE 17th International Conference on Thermoelectrics*. Nagoya, Japan: IEEE Publishing. 464–467.
- Korprasertsak, N., and T. Leephakpreeda. 2017. "Real-Time Determination of Convective Heat Transfer Coefficient Via Thermoelectric Modules." *Journal Of Heat Transfer-Transactions of the ASME* 139, no. 10 .
- Law, Averill M. 2015. *Simulation Modeling and Analysis*. New York: McGraw-Hill Education.
- Lynn, Ann. 2012. "Mid-West Gateway Events." *INCOSE*. April 30, 2012. [https://www.incose.org/docs/default-source/midwest-gateway/events/incose-midwest\\_2012-04-30\\_lynn\\_presentation.ppt](https://www.incose.org/docs/default-source/midwest-gateway/events/incose-midwest_2012-04-30_lynn_presentation.ppt).
- Moreno, Rondolf, Dragoslav Grbovic, and Anthony Pollman. 2019. "Using Modeling and Simulations to Characterize TEG Arrays." In *Proceedings of the International Conference of Innovative Applied Energy 2019 1* (IAPE2019): 1–5., Oxford, UK. [http://iape-conference.org/Downloads/Proceedings/Articles%20\(Abstracts%20&%20Papers\)/a-1-Article-051.pdf](http://iape-conference.org/Downloads/Proceedings/Articles%20(Abstracts%20&%20Papers)/a-1-Article-051.pdf).

- Moreno, Rondolf J., Anthony G. Pollman, Dragoslav Grbovic. 2018. "Harvesting Waste Thermal Energy from Military Systems." In *Proceedings of the ASME Power and Energy Conference 2018 2* (Power2018-7514): 1–6., Lake Buena Vista, FL. <http://proceedings.asmedigitalcollection.asme.org/proceeding.aspx?articleid=2706310&resultClick=3>.
- Orchard-Hays, Daniel, and Laura A. King. 2017. "Realize the Great Green Fleet." *Proceedings Magazine*, August 2017.
- Percy, Steven, Chris Knight, Scott McGarry, Alex Post, Tim Moore, and Kate Cavanagh. 2014. *Thermal Energy Harvesting for Application at MEMS Scale*. New York: Springer New York.
- Pollman, Anthony. 1997. "Energy Optimization: A Combat Multiplier." *Marine Corps Gazette* 97, no. 11: 69–73.
- Reddy, Bvk, Matthew Barry, John Li, and MInking Chyu. 2013. "Thermoelectric Performance of Novel Composite and Integrated Devices Applied to Waste Heat Recovery." *Journal of Heat Transfer* 135, no. 3.
- Schock, Harold, Giles Brereton, Eldon Case, Jonathan D'angelo, Tim Hogan, Matt Lyle, Ryan Maloney et al. 2013. "Prospects for Implementation of Thermoelectric Generators As Waste Heat Recovery Systems In Class 8 Truck Applications." *Journal of Energy Resources Technology* 135, no. 2.
- Sheikholeslami, Ali. 2018. "Thévenin and Norton Equivalent Circuits: Part 1." *IEEE Solid-State Circuits Magazine*, June 22, 2018: 8–10.
- Stewart, George. 2016. "Commercial Use of Marine Gas Turbines." Navy History. <http://www.navyhistory.org/2016/12/commercial-use-of-marine-gas-turbines/>.
- TEG Mart. 2014. "TEG Modules." <http://www.tegmart.com/datasheets/TGPR-22W-7V.pdf>.
- Thomas, Matthew J. 2015. "Conjunction of Photovoltaic and Thermophotovoltaic Power Production in Spacecraft Power Systems," M.S. Thesis. Monterey: Naval Postgraduate School.
- Tian, Zhiting, Sangyeop Lee, and Gang Chen. 2013. "Heat transfer in Thermoelectric Materials and Devices." *Journal of Heat Transfer* 135, no. 6.
- Timings, R. L., and Peter Twigg. 2001. *Pocket Dictionary of Engineering Terms*, S.v. "sensible heat (in Engineering science)." [http://libproxy.nps.edu/login?url=http%3A%2F%2Fsearch.credoreference.com%2Fcontent%2Fentry%2Fbhidet%2Fsensible\\_heat\\_in\\_engineering\\_science%2F0%3FinstitutionId%3D901](http://libproxy.nps.edu/login?url=http%3A%2F%2Fsearch.credoreference.com%2Fcontent%2Fentry%2Fbhidet%2Fsensible_heat_in_engineering_science%2F0%3FinstitutionId%3D901).

- U.S. Army. 2012. "Army Delivers Fuel-Efficient Generators, 'Right-Size' Power to Afghanistan." [https://www.army.mil/article/87545/army\\_delivers\\_fuel\\_efficient\\_generators\\_right\\_size\\_power\\_to\\_afghanistan](https://www.army.mil/article/87545/army_delivers_fuel_efficient_generators_right_size_power_to_afghanistan).
- U.S. Department of Energy. 2017. "Waste Heat Recovery Resource Page." January 24. <https://www.energy.gov/eere/amo/articles/waste-heat-recovery-resource-page>.
- We, Ju Hyung, Sun Jin Kim, and Byung Jin Cho. 2014. "Hybrid Composite of Screen-Printed Inorganic Thermoelectric Film and Organic Conducting Polymer for Flexible Thermoelectric Power Generator." *Energy* 73 73: 506–512.

## INITIAL DISTRIBUTION LIST

1. Defense Technical Information Center  
Ft. Belvoir, Virginia
2. Dudley Knox Library  
Naval Postgraduate School  
Monterey, California