

UNCLASSIFIED

Registration No.

OPSEC683



**TARDEC Fixed Seat: Non-Driver
CAD Accommodation Model
Verification Plan**

Gale L. Zielinski and Frank J. Huston II

US Army TARDEC, Warren, MI

**UNCLASSIFIED: Distribution Statement A
Approved for Public Release**

21 February 2018

U.S. Army Tank Automotive Research,
Development, and Engineering Center
Detroit Arsenal
Warren, Michigan 48397-5000

UNCLASSIFIED

| REPORT DOCUMENTATION PAGE | | | <i>Form Approved</i> <i>OMB No. 0704-0188</i> | |
|--|-------------------------------------|--|--|--|
| Public reporting burden for this collection of information is estimated to average 1 hour per response, including the time for reviewing instructions, searching existing data sources, gathering and maintaining the data needed, and completing and reviewing this collection of information. Send comments regarding this burden estimate or any other aspect of this collection of information, including suggestions for reducing this burden to Department of Defense, Washington Headquarters Services, Directorate for Information Operations and Reports (0704-0188), 1215 Jefferson Davis Highway, Suite 1204, Arlington, VA 22202-4302. Respondents should be aware that notwithstanding any other provision of law, no person shall be subject to any penalty for failing to comply with a collection of information if it does not display a currently valid OMB control number. PLEASE DO NOT RETURN YOUR FORM TO THE ABOVE ADDRESS. | | | | |
| 1. REPORT DATE <i>03/07.2014</i> 21 February 2018 | | 2. REPORT TYPE Verification Plan | | 3. DATES COVERED (From - To) Jan 2017 - Feb 2018 |
| 4. TITLE AND SUBTITLE TARDEC Fixed Seat: Non-Driver CAD Accommodation Model Verification Plan | | | 5a. CONTRACT NUMBER N/A | |
| | | | 5b. GRANT NUMBER N/A | |
| | | | 5c. PROGRAM ELEMENT NUMBER N/A | |
| 6. AUTHOR(S) Gale L. Zielinski and Frank J. Huston II | | | 5d. PROJECT NUMBER N/A | |
| | | | 5e. TASK NUMBER N/A | |
| | | | 5f. WORK UNIT NUMBER N/A | |
| 7. PERFORMING ORGANIZATION NAME(S) AND ADDRESS(ES) AND ADDRESS(ES) RDECOM-TARDEC-ACT Attn: RDTA-SIE-EA-ADCON-TIC MS 207 6501 E. 11 Mile Road, Warren, MI 48397-5000 | | | 8. PERFORMING ORGANIZATION REPORT NUMBER N/A | |
| 9. SPONSORING / MONITORING AGENCY NAME(S) AND ADDRESS(ES) N/A | | | 10. SPONSOR/MONITOR'S ACRONYM(S) N/A | |
| | | | 11. SPONSOR/MONITOR'S REPORT NUMBER(S) N/A | |
| 12. DISTRIBUTION / AVAILABILITY STATEMENT UNCLASSIFIED: Distribution Statement A. Approved for Public Release, Unlimited Distribution | | | | |
| 13. SUPPLEMENTARY NOTES N/A | | | | |
| 14. ABSTRACT Military ground vehicles are currently designed using requirements from MIL-STD-1472G, the <i>Department of Defense Design Criteria Standard Human Engineering</i> . The MIL-STD, however, is difficult for designers to apply properly because it is often open to interpretation. Easy to use Computer-Aided Design (CAD) tools, such as accommodation models, are needed by the ground vehicle community, to address this issue (Zielinski, Huston II, Kozycski, Kouba, & Wodzinski, 2015). The second in a series of accommodation models being created is the Fixed Seat: Non-Driver accommodation model. Verification is intended to build confidence in the Fixed Seat: Non-Driver CAD model for use in ground vehicle design. This model is applicable to ground vehicles with fixed seating positions which are often located in the rear of the vehicle. The fixed seats have no horizontal or vertical seat track adjustment and likely includes a seat back that is also stationary. The Fixed Seat: Non-Driver CAD model is intended to provide the composite boundaries representing the body of the defined user population, including posture prediction. The boundaries defined provide required space claim for the equipped users helmet, eyes, torso, and knees. Clearances between the user and surrounding interior vehicle surfaces have been added per MIL-STD- 1472G (e.g. head clearance required from head (helmet) to vehicle roof line and thigh clearance to the steering wheel). | | | | |
| 15. SUBJECT TERMS Fixed Seat: Non-Driver, accommodation model, occupant work space, user population, equipped, ensemble, posture and position, verification, computer aided design (CAD) | | | | |
| 16. SECURITY CLASSIFICATION OF: | | | 17. LIMITATION OF ABSTRACT UNLIMITED | 18. NUMBER OF PAGES 24 |
| a. REPORT UNLIMITED | b. ABSTRACT UNLIMITED | c. THIS PAGE UNLIMITED | | |
| | | | 19b. TELEPHONE NUMBER (include area code) (586) 282-5287 | |

Standard Form 298
(Rev. 8-98)
Prescribed by ANSI Std.
Z39.18

**TANK-AUTOMOTIVE RESEARCH
DEVELOPMENT ENGINEERING CENTER**

Warren, MI 48397-5000

21 February 2018
Revision 1.0

**TARDEC Fixed Seat: Non-Driver
CAD Accommodation Model
Verification Plan**

By

Gale L. Zielinski, Frank J. Huston II



REVISION HISTORY

| Version No. | Date | Changes |
|-------------|----------------------|----------|
| 1.0 | 21 – February - 2018 | Original |
| | | |
| | | |

Contents

| | | |
|-------|---|----|
| 1. | V&V PLAN EXECUTIVE SUMMARY | 8 |
| 2. | PROBLEM STATEMENT..... | 9 |
| 2.1 | Intended Use | 9 |
| 2.2 | M&S Overview | 9 |
| 2.3 | M&S Application | 10 |
| 2.3.1 | Model Origin | 10 |
| 2.3.2 | Model Inputs | 11 |
| 2.3.3 | Model Outputs – Based on UMTRI Seated Soldier Study..... | 12 |
| 2.3.4 | Model Outputs – Based on MIL-STD 1472G..... | 13 |
| 2.4 | Verification Scope..... | 14 |
| 3. | REQUIREMENTS AND ACCEPTABILITY CRITERIA | 14 |
| 4. | CAPABILITIES, LIMITATIONS, ASSUMPTIONS (CLA), RISKS/IMPACTS | 16 |
| 4.1 | M&S Capabilities..... | 16 |
| 4.2 | M&S Limitations | 16 |
| 4.3 | M&S Assumptions | 16 |
| 4.4 | M&S Risks/Impacts | 17 |
| 5. | VERIFICATION & VALIDATION (V&V) METHODOLOGY | 17 |
| 5.1 | Planned Data Verification Tasks | 17 |
| 5.2 | Planned Model Verification | 18 |
| 5.2.1 | Planned Model Verification Test Run | 18 |
| 5.3 | Planned Verification Reporting..... | 18 |
| 6. | KEY PARTICIPANTS | 18 |
| 7. | PLANNED VERIFICATION RESOURCES | 20 |
| 7.1 | Verification Resource Requirements..... | 20 |
| 7.2 | Verification Milestones and Timeline | 20 |
| 8. | Appendices | 21 |
| 8.1 | Appendix A – References | 21 |
| 8.2 | Appendix B – Acronyms..... | 22 |
| 8.3 | Appendix C – Distribution List..... | 23 |

List of Figures

| | |
|--|----|
| Figure 1: HARP Represented in Seat CAD | 11 |
| Figure 2: Fixed Seat: Non-Driver CAD Model Example Output..... | 13 |

List of Tables

| | |
|---|----|
| Table 1: Fixed Seat: Non-Driver Accommodation Model Inputs | 11 |
| Table 2: Squad Accommodation Model Outputs | 12 |
| Table 3: Fixed Seat: Non-Driver Accommodation Model Outputs and Definitions based on MIL-STD 1472 | 13 |
| Table 4: Requirements Relationship Table | 14 |
| Table 5: Requirements Relationship Table for Boundary Manikins | 15 |
| Table 6: Fixed Seat: Non-Driver CAD Accommodation Model Test Matrix | 18 |
| Table 7: Key Participants for FHP Accommodation Model VV&A | 19 |
| Table 8: Fixed Seat: Non-Driver Accommodation Model V&V Schedule..... | 20 |

ACKNOWLEDGEMENTS

The authors would like to acknowledge the contributions of the following individuals for their assistance in the creation of this report:

Cheryl A. Burns, Army Research Laboratory Human Research and Engineering
Directorate (ARL HRED)

Richard W. Kozycki (ARL HRED)

Matthew P. Reed, PhD, University of Michigan Transportation Research Institute
(UMTRI)

1. V&V PLAN EXECUTIVE SUMMARY

Military ground vehicles are currently designed using requirements from MIL-STD-1472G, the *Department of Defense Design Criteria Standard: Human Engineering*. The MIL-STD, however, is difficult for designers to apply properly because it is often open to interpretation. Easy to use Computer-Aided Design (CAD) tools are needed by the ground vehicle community to address this issue. The CAD tools being developed are called accommodation models. Accommodation models are constructed from 3D empirical data for a given seating configuration to provide population workspace boundaries that include the effects of both anthropometry and posture (Zielinski, Huston II, Kozycki, Kouba, & Wodzinski, 2015). The verification effort is intended to build confidence in accommodation models for use in ground vehicle design.

The model described in this verification plan is the Tank Automotive Research, Development, and Engineering Center (TARDEC) Fixed Seat: Non-Driver CAD model. This model is applicable to ground vehicles with fixed seating positions which are often located in the rear of the vehicle. The fixed seats have no horizontal or vertical seat track adjustment and likely includes a seat back that is also stationary. The occupant in this position has few seated tasks interacting with the rest of ground vehicle. The TARDEC Fixed Seat: Non-Driver CAD model is intended to provide the composite boundaries representing the body of the defined user population, including the effects of body size, and protective equipment and gear. The boundaries defined include the required space needed for the equipped users' helmet, eyes, torso, and knees. Clearances between the user and surrounding interior vehicle surfaces have been added per MIL-STD- 1472G (e.g. head clearance required from head (helmet) to vehicle roof line). The Fixed Seat: Non-Driver model is a statistical model created utilizing data collected in the *Seated Soldier Study* (Reed & Ebert, 2013) completed by the University of Michigan Transportation Research Institute (UMTRI). The original model, as provided by UMTRI, consists of a Microsoft Excel workbook. The CAD version of the model was created using PTC Creo® 3D CAD software and is a stand-alone geometric reproduction of the output found in the UMTRI Microsoft Excel spreadsheet.

This CAD accommodation model can be applied early in the vehicle design process to ensure accommodation requirements are met and help explore possible design tradeoffs when conflicts with other design parameters exist. Vehicle designers can use the TARDEC Fixed Seat: Non-Driver CAD accommodation model for the following scenarios: 1) during the concept and design phase of new acquisition programs, 2) while upgrading existing ground vehicle platforms, and 3) for assessing a commercial off the shelf (COTS) system. Human factors engineers could benefit by working with vehicle designers to perform virtual assessments in CAD when there is not enough time and/or funding to translate vehicle models into compatible formats for assessment and perform detailed human figure modeling.

The Fixed Seat: Non-Driver CAD accommodation model verification effort will produce a verification report that captures the results of the activities completed as described in this plan. Any areas that do not meet the defined verification acceptability requirements will be reviewed and an action item will be assigned to correct the issue. The verification report will be signed off by the model developers along with the respective Verification and Validation (V&V) SMEs.

2. PROBLEM STATEMENT

Military ground vehicles are currently designed using requirements from MIL-STD-1472, the *Department of Defense Design Criteria Standard: Human Engineering*. The requirement to accommodate the central 90 percent of the user population in which the fully equipped user can sit safely and comfortably while performing all required functions, requires multivariate analysis methods so that both the users' anthropometry and posture can be considered. MIL-STD-1472G is often open to interpretation and is therefore difficult for designers to apply consistently. Easy to use, valid design tools and procedures based on these methods are needed to effectively design vehicle workstations. The chosen tools are CAD based accommodation models adapted for users in military ground vehicles, that directly parallel long-standing SAE recommended practices used in the commercial automotive and truck domains (Zielinski, Huston II, Kozycki, Kouba, & Wodzinski, 2015). The second CAD model developed is the TARDEC Fixed Seat: Non-Driver CAD accommodation model, known throughout the rest of this report as the Fixed Seat: Non-Driver CAD model.

2.1 Intended Use

The Fixed Seat: Non-Driver CAD model described in this verification plan is applicable to ground vehicles with fixed seating positions which are often located in the rear of the vehicle. The fixed seats have no horizontal or vertical seat track adjustment and likely includes a seat back that is also stationary. The user in this position has few seated tasks interacting with the rest of the ground vehicle.

The Fixed Seat: Non-Driver CAD model is intended to provide the composite boundaries representing the body of the defined user population, including the effects of body size, and protective equipment and gear. The boundaries defined include the required space needed for the equipped users' helmet, eyes, torso, and knees. Clearances between the user and surrounding interior vehicle surfaces have been added per MIL-STD-1472G (e.g. head clearance required from head (helmet) to vehicle roof line).

2.2 M&S Overview

The Fixed Seat: Non-Driver CAD model is a statistical model created utilizing data collected in the *Seated Soldier Study* (2013) completed by UMTRI. The original model, consists of a Microsoft Excel workbook. The CAD version of the model was created using PTC Creo® 3D CAD software and is a stand-alone geometric reproduction of the output found in the UMTRI Microsoft Excel spreadsheet.

Model inputs include the definition of the target design population (a subset of the Army Anthropometric Survey (ANSUR) II), the ensemble (clothing and equipment worn by the user), the desired level of accommodation (for example, 90%), the seat height and seat back angle, and the target population gender mix. The ensemble is selectable as either Personal Protective Equipment (PPE) which includes the Improved Outer Tactical Vest (IOTV) or Encumbered (ENC) which includes the PPE and Tactical Assault Panel (TAP) with Squad Automatic Weapon (SAW) Gunner kit, both of which are defined in the *Seated Soldier Study*. Ideally, the level of accommodation will be set at the central 90% of the target design population to be consistent with MIL-STD-1472G requirements. The only vehicle inputs to the model are the seat height and seat back angle, determined by measuring the Human Accommodation Reference Point (HARP) using either a SAE J826 H-point manikin or the ISO 5353 Seat Index Point (SIP) tool. It should be noted that the 2010 ANSUR of U.S. Marine Corps (USMC) Personnel can also be added to the model if USMC anthropometry is needed for design.

The Fixed Seat: Non-Driver CAD model represents the posture and position variability for the entire selected target user population (e.g. central 90%, 85% male). The model can guide vehicle designers in creating an optimized workspace for the user. The CAD accommodation model, along with additional added space claims for human factors, can be used to visualize MIL-STD-1472G requirements. This eliminates the concern of inconsistent application of the MIL-STD by vehicle designers when creating the occupant workspace (Zielinski et al., 2015).

2.3 M&S Application

The use of the Fixed Seat: Non-Driver CAD model provides the opportunity to apply Human Systems Integration (HSI) very early in the acquisition process. The model could be utilized during the Material Solution Analysis Phase prior to Milestone (MS)A and up through and including MSB. Past programs have not actively engaged HSI until MSB or the Engineering Manufacturing and Development (EMD) Phase, resulting in significant design and cost changes.

This Fixed Seat: Non-Driver CAD model can be used to explore possible design tradeoffs when conflicts with other design parameters exist. Vehicle designers can use the model for the following scenarios: 1) during the concept and design phase of new acquisition programs, 2) while upgrading existing ground vehicle platforms, and 3) for assessing a commercial off the shelf (COTS) system. Human factors engineers could benefit by working with vehicle designers to perform virtual assessments in CAD when there is not enough time and/or funding to translate vehicle models into assessment software compatible formats and perform detailed human figure modeling.

2.3.1 Model Origin

The Human Accommodation Reference Point (HARP), Figure 1, is the origin for the Fixed Seat: Non-Driver accommodation model. The HARP is a reference point for predicting human posture and position with respect to the seat that defines the seat location for analysis of occupant

accommodation. The HARP is defined and measured using either the SAE J826 H-point manikin with associated procedures or the ISO 5353 SIP device and the associated procedures presented in UMTRI-2014-33.

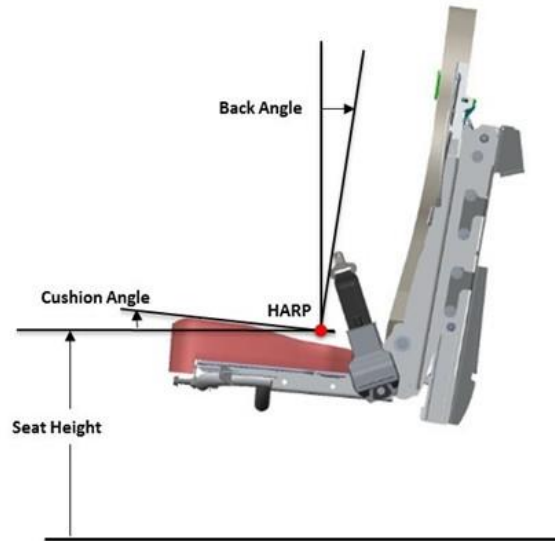

Figure 1: HARP Represented in Seat CAD

2.3.2 Model Inputs

The Fixed Seat: Non-Driver accommodation model requires seven inputs; these are listed in Table 1 below.

Table 1: Fixed Seat: Non-Driver Accommodation Model Inputs

| | |
|--------------------------------|--|
| Target Accommodation | The percentage of the target design population to be accommodated. The occupants not accommodated are evenly split between the smaller and larger extremes of the population. In MIL-STD-1472G (2012), the accommodation target has been set at 90%. |
| Fraction Male | The percentage of males in the defined target design population. |
| Ensemble | Clothing and equipment available for selection in the model: <ul style="list-style-type: none"> • ¹PPE = ACU + IOTV + ACH • ²ENC = ACU + PPE + SAW Gunner |
| Seat Height | The height of the seat, as measured to the seat’s HARP, above the heel rest surface (typically, the floor). |
| Seat Back Angle | The angle, from vertical, of the fixed seat back. |
| Consider Hydration Pack Relief | A seatback with hydration pack relief can fully accommodate an occupant’s hydration pack such that the occupant’s position in the seat is the same regardless of wearing a hydration pack. The following selection will be available in the model: <ul style="list-style-type: none"> • Yes • No |

| | |
|---|--|
| Human Accommodation Reference Point (HARP) Tool | Indicates which HARP measurement device has been chosen for the occupant’s seat. The two options of seat design HARP measurement tools are the Society of Automotive Engineers (SAE) J826 H-point manikin and Seat Index Point (SIP) tool (Reed & Ebert, 2014). The following selection will be available in the model: <ul style="list-style-type: none"> • SAE J826 • ISO 5353 |
|---|--|

¹ Personal Protective Equipment (PPE), Improved Outer Tactical Vest (IOTV) that included Enhanced Small Arms Protective Insert (ESAPI) plates, Enhanced Side Ballistic Inserts (ESBI), and Advanced Combat Helmet (ACH)

² Encumbered (ENC), SAW Gunner defined in the Soldier Load Configurations in Ground Vehicles (McNamara, 2012) and Seated Soldier Study (Reed et al, 2013).

2.3.3 Model Outputs – Based on UMTRI Seated Soldier Study

The primary model outputs include the user population boundaries and preferred boundary manikin posture and position information for the vehicle designer to utilize when creating or assessing an occupant workspace. Model outputs are described below in Table 2.

Table 2: Squad Accommodation Model Outputs

| | |
|---------------------------------------|---|
| Eyellipse | The eyellipse (a contraction of the words "eye" and "ellipse") depicts the distribution of occupant eye locations in the vehicle (Reed, 2015). |
| Helmet Boundary | The helmet boundary depicts the distribution of target design population helmet locations in the vehicle. The Advanced Combat Helmet (ACH) was used in the development of all the accommodation models (Reed, 2015). |
| Knee Boundary Including Leg and Thigh | The knee boundary with leg and thigh depicts the top, forward, and lateral distribution of the resting knee location in vehicle. |
| Elbow Boundary | The elbow boundary depicts the distribution of resting elbow locations of the occupant (Reed, 2016). |
| Boundary Manikin Posture and Position | The boundary manikin posture and position predicts seat position and torso posture for a family of simulated drivers based on the vehicle configuration and the anthropometric inputs of stature, body weight, and erect sitting height (Reed, 2013). |

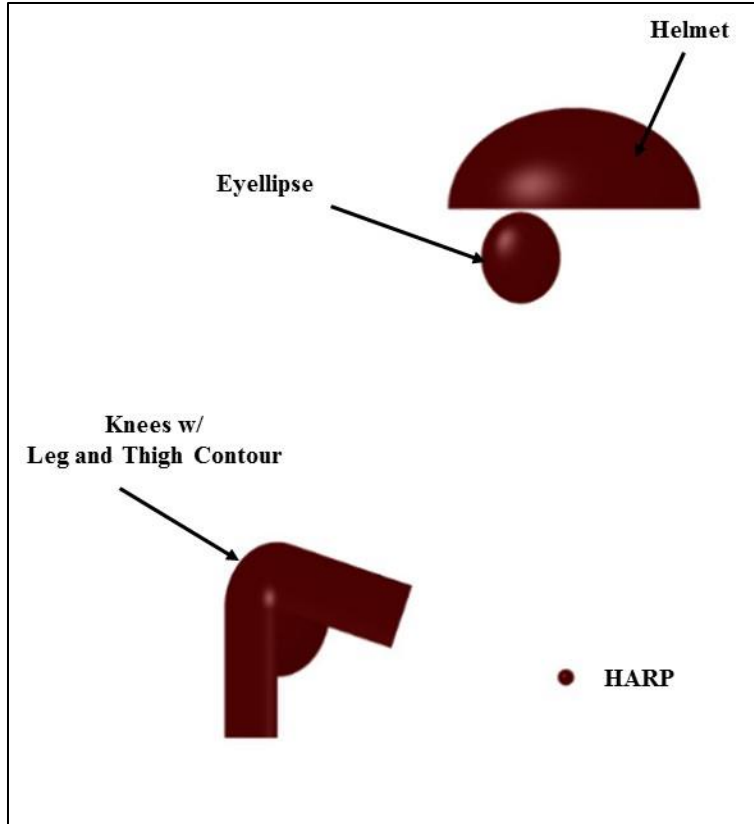

Figure 2: Fixed Seat: Non-Driver CAD Model Example Output

2.3.4 Model Outputs – Based on MIL-STD 1472G

Additional outputs of the model include interpretation of MIL-STD 1472G for the vehicle designer to utilize when creating the occupant workspace. Model outputs are described below in Table 3 and shown in Figure 4.

Table 3: Fixed Seat: Non-Driver Accommodation Model Outputs and Definitions based on MIL-STD 1472

| | |
|---|--|
| Helmet Clearance | The helmet clearance represents a 2-inch space claim required above the helmet boundary to provide clearance to vehicle ceiling and nearby equipment. |
| Field of View (FOV) Forward and Lateral | The FOV represents the area where items that occupants may need to view while seated should be placed. |
| Knee Boundary Including Leg and Thigh Clearance | The knee boundary along with leg and thigh is used to assess clearance to doors, consoles, racks, and any other surrounding components. The knee boundary depicts the top, forward, and lateral distribution of the resting driver knee location in vehicle. |

2.4 Verification Scope

The scope of this effort is to verify the TARDEC CAD accommodation model for a Fixed Seat: Non-Driver position where the fixed seats have no horizontal or vertical seat track adjustment and likely includes a seat back that is also stationary. This CAD accommodation model can be applied early in the vehicle design process to ensure accommodation requirements are met and help explore possible design tradeoffs when conflicts with other design parameters exist. The verification is intended to build confidence in the Fixed Seat: Non-Driver accommodation model for use in the ground vehicle design community.

Verification per the *Department of Defense Standard Practice Documentation of Verification, Validation, and Accreditation (VV&A) for Models and Simulation* (2008) is defined as follows:

Verification is the process of determining that a model, simulation, or federation of models and simulations implementations and their associated data accurately represents the developer’s conceptual description and specifications.

3. REQUIREMENTS AND ACCEPTABILITY CRITERIA

The TARDEC Fixed Seat: Non-Driver CAD accommodation model shall meet the requirements shown in Table 4 below.

Table 4: Requirements Relationship Table

| # | M&S Requirement | Acceptability Criteria | Metrics/Measures |
|---|---|---|---|
| 1 | Model allows for selection of seat hydration pack relief in the seat | 1.1 Hydration pack relief selection of “yes” in model | 1.1 Representative (Pass) / Non-Representative (Fail) |
| | | 1.2 Hydration pack relief selection of “no” in model | 1.2 Representative (Pass) / Non-Representative (Fail) |
| 2 | Model allows for selection of either SAE J826 or ISO 5353 for the Human Accommodation Reference Point (HARP) measurement tool | 2.1 HARP measurement tool selection of SAE J826 in model | 2.1 Representative (Pass) / Non-Representative (Fail) |
| | | 2.2 HARP measurement tool selection of ISO 5353 in model | 2.2 Representative (Pass) / Non-Representative (Fail) |
| 3 | Model allows for input of the population gender mix (e.g. 85% Male : 15% Female) | 3.1 Fraction male input option in model | 3.1 Representative (Pass) / Non-Representative (Fail) |
| 4 | Model allows for selection of ensemble as either PPE or ENC | 4.1 Ensemble selection of PPE in model | 4.1 Representative (Pass) / Non-Representative (Fail) |
| | | 4.2 Ensemble selection of ENC in model | 4.2 Representative (Pass) / Non-Representative (Fail) |
| 5 | Model allows for a target population input (e.g. 90%) | 5.1 Target accommodation input option in model | 5.1 Representative (Pass) / Non-Representative (Fail) |
| 6 | Model allows for input of the seat height | 6.1 Seat height input option in model | 6.1 Representative (Pass) / Non-Representative (Fail) |
| 7 | Model allows for input of the seat back angle | 7.1 Seat back angle input option in model | 7.1 Representative (Pass) / Non-Representative (Fail) |
| 8 | Model predicts the dimensions and location of the eyellipse | 8.1 Model outputs a left and right eyellipse for a given population and gender mix that adjusts with different inputs | 8.1 Representative (Pass) / Non-Representative (Fail) |

| | | | |
|----|--|--|--|
| | | 8.2 TARDEC CAD model matches the UMTRI spreadsheet | 8.2 Representative (Pass) / Non-Representative (Fail) |
| 9 | Model predicts the helmet contour boundary (helmet locations) with respect to the eye location and fitted to the eyellipse | 9.1 Model outputs a helmet contour for the given population and gender mix that adjusts with the different inputs | 9.1 Representative (Pass) / Non-Representative (Fail) |
| | | 9.2 TARDEC CAD model matches the UMTRI spreadsheet | 9.2 Representative (Pass) / Non-Representative (Fail) |
| 10 | Model predicts the knee contour with leg and thigh segment angles based on location of resting occupants' knees in vehicle | 10.1 Model outputs a knee ellipsoid for the given population and gender mix that adjusts with different inputs | 10.1 Representative (Pass)/ Non-Representative (Fail) |
| | | 10.2 TARDEC CAD model matches the UMTRI spreadsheet | 10.2 Representative (Pass)/ Non-Representative (Fail) |
| 11 | Model predicts elbow contours based on location of resting occupants' elbows in vehicle | 11.1 Model outputs elbow contours for the given population and gender mix that adjusts with different inputs | 12.1 Representative (Pass)/ Non-Representative (Fail) |
| | | 11.2 TARDEC CAD model matches the UMTRI spreadsheet | 12.2 Representative (Pass)/ Non-Representative (Fail) |
| 12 | Model provides a clearance zone for the head (helmet) to roof line based on a back calculation from MIL-STD-1472G requirements | 12.1 Model outputs a 2" clearance zone from the top of the helmet contour that adjusts with the different inputs | 12.1 Representative (Pass) / Non-Representative (Fail) |
| 13 | Model provides a clearance zone for the knee, leg and thigh based on MIL-STD-1472H draft recommendations | 13.1 Model outputs a 2" clearance zone from the top and front of the knee contour and the front of the leg segment and top of the thigh (in side-view) and adjusts with different inputs | 13.1 Representative (Pass) / Non-Representative (Fail) |
| 14 | Model provides a lateral clearance zone for the elbow contours based on MIL-STD-1472H draft recommendations | 14.1 Model output provides a 2" clearance zone laterally for the resting elbow contours | 14.1 Representative (Pass)/ Non-Representative (Fail) |
| 15 | Model provides direct field of view (primary zones) based on MIL-STD-1472G and SAE J1050 | 15.1 Model outputs primary vision zone that adjusts with model inputs | 15.1 Representative (Pass)/ Non-Representative (Fail) |

Along with using the Fixed Seat: Non-Driver CAD model, ground vehicle designers will use boundary manikins when creating the interior workspace. The boundary manikins, will be postured and positioned in CAD using the posture prediction model created by UMTRI. The requirement for posture prediction is shown in Table 5 below.

Table 5: Requirements Relationship Table for Boundary Manikins

| # | M&S Requirement | Acceptability Criteria | Metrics/Measures |
|---|---|---|---|
| 1 | Model predicts the location of the hip with respect to the HARP | 1.1 Model outputs the location of the hip with respect to the HARP that matches the UMTRI spreadsheet | 1.1 Representative (Pass) / Non-Representative (Fail) |
| | | 1.2 The manikin hip joint center aligns with the hip point | 1.2 Representative (Pass) / Non-Representative (Fail) |

| | | | |
|---|---|---|---|
| 2 | Model predicts the location of the eye with respect to the HARP | 2.1 Model outputs the location of the eye with respect to the HARP that matches the UMTRI spreadsheet | 2.1 Representative (Pass) / Non-Representative (Fail) |
| | | 2.2 The manikin eye aligns with the eye point | 2.2 Representative (Pass) / Non-Representative (Fail) |

4. CAPABILITIES, LIMITATIONS, ASSUMPTIONS (CLA), RISKS/IMPACTS

4.1 M&S Capabilities

The Fixed Seat: Non-Driver CAD model will provide government and industry partners with the following M&S capabilities:

- Relevant population boundaries for user posture in an occupant workspace
- Posture prediction for the identified boundary manikins
- Clearances based on interpretation of MIL-STD-1472G
- FOV based on interpretation of MIL-STD-1472G and SAE J1050

4.2 M&S Limitations

The Fixed Seat: Non-Driver CAD model has limitations based on the ground vehicle requirements for the occupant workspace, as follows:

- Predicts fixed seat squad conditions only and does not address other special positions with a fixed seat such as a gunner.
- Cannot be used if horizontal and vertical seat travel are integrated into the seat design.
- Predicts where the Soldiers ideally want to posture and position themselves but does not include vehicle limitations such as low ceiling height or limited leg room.
- Model was created with a specific range of clothing and equipment kit weights and depths, so it will have to be reevaluated if the clothing and equipment kits drastically change.
- Predicts Soldiers' preferred postures and positions but does not take into consideration posture changes due to restricted environments.
- CAD accommodation models serve as a design tool and are not intended to replace, but rather complement, HFE assessment tools.

4.3 M&S Assumptions

The development of a valid Fixed Seat: Non-Driver CAD model is based on the following assumptions:

- The fixtures created and used by UMTRI to collect the occupant data are representative of a fixed seating type environment in the back of a ground vehicle.
- Analysis methods used by UMTRI accurately predict the users preferred posture and position.
- Position data collected in a static environment over a short period of time are reasonably similar to users' preferred postures and positions during long-duration driving.

4.4 M&S Risks/Impacts

The constraints and limitations highlighted above could potentially result in an interior workspace design that is not fully optimized. This risk will be mitigated by Subject Matter Experts (SMEs) from Army Research Laboratory (ARL) Human Research and Engineering Directorate (HRED) who complete human factors assessments on the proposed designs, COTS vehicles, and demonstrators during the acquisition process IAW AR 602-2. This assessment will be captured in documentation completed by the ARL HRED SMEs.

5. VERIFICATION & VALIDATION (V&V) METHODOLOGY

Verification tasks have been tailored according to need, value added, resources, and funding. The selected tasks address the acceptability criteria outlined in Section 3 of this report. The verification process will establish if UMTRI's data was used correctly to create the TARDEC CAD model. The validation process, when completed, will determine if the model aligns with the real-world environment. The model data will be validated by Subject Matter Expert (SME) by in-vehicle data collection and human factors assessments on one to four existing Army vehicles (e.g. Bradley Infantry Fighting Vehicle (IFV), Stryker Infantry Carrier Vehicle (ICV), Mine Resistant Ambush Protected (MRAP) Vehicle All-Terrain Vehicle (ATV), etc.) or ground vehicle demonstrators.

5.1 Planned Data Verification Tasks

TARDEC Advanced Concepts Team (ACT) is the creator of the Fixed Seat: Non-Driver CAD model. TARDEC ACT has minimal Data V&V tasks planned since UMTRI, as the data developer, documented the methods and results of the data collection. The data and statistical techniques employed by UMTRI are appropriate for the creation of the models. Standard anthropometric data was collected on the study participants, and the distributions of important body dimensions were similar to those in ANSUR II data. In addition, a whole-body laser scanner was used to record body shape in both seated and standing posture. Statistical analysis of body landmark data was conducted by UMTRI and validation of the data for the models to predict Soldier posture, as a function of vehicle factors, was completed (Reed, et al, 2013). UMTRI's work has been captured in the following documents:

- UMTRI-2013-13, *Seated Soldier Study: Posture and Body Shape in Vehicle Seats*, Final Report dated October 2013
- UMTRI-2014-39, *Development of Accommodation Models for Soldiers in Vehicles: Squad*, Final Report dated September 2014
- UMTRI Excel spreadsheet, *Soldier Squad Accommodation Models 2018-02-15*
- UMTRI Excel spreadsheet, *Seated Soldier Posture Prediction 2014-09-01*

The information provided by UMTRI was used to create the Fixed Seat: Non-Driver CAD model. To verify UMTRI's work, TARDEC ACT reviewed each Excel spreadsheet to verify that

it aligned with the written reports and then used the information as the basis for the creation of the CAD model.

5.2 Planned Model Verification

The CAD accommodation model developer (TARDEC ACT), working with the V&V agent (TARDEC ACT and ARL HRED), will compare the output received in CAD to the output shown in the UMTRI *Soldier Squad Accommodation Models 2016-02-22* Excel spreadsheet and verify that the two correlate. The model input values will be changed to ensure that the helmet boundary, helmet boundary clearance, eyellipse, FOV, knee boundary, leg and thigh, and elbow boundary all adjust as expected

5.2.1 Planned Model Verification Test Run

An audit of the Fixed Seat: Non-Driver CAD model will be completed with the M&S proponent, V&V agent, and SMEs. TARDEC ACT will adjust input values of the accommodation model and the team will verify that the outputs previously defined in Table 2 adjust as expected. The test matrix to be used for the verification of the model is shown in Table 6 below:

Table 6: Fixed Seat: Non-Driver CAD Accommodation Model Test Matrix

| Test | Target Accommodation | Seat Height (H30) Z (Vertical) in. (mm) | Seat Back Angle (A40) (degrees) | Fraction Male | Ensemble | HARP Measurement Tool | Seat Hydration Pack Relief |
|------|----------------------|---|---------------------------------|---------------|----------|-----------------------|----------------------------|
| 1 | 90% | 13.8 (350) | 0.0 | 90% | PPE | SAE J826 | No |
| 2 | 90% | 15.0 (380) | 20.0 | 90% | PPE | SAE J826 | No |
| 3 | 90% | 15.8 (400) | 15.0 | 90% | PPE | ISO 5353 | No |
| 4 | 90% | 17.7 (450) | 18.0 | 90% | PPE | SAE J826 | No |
| 5 | 90% | 15.0 (380) | 10.0 | 90% | PPE | SAE J826 | No |
| 6 | 90% | 15.0 (380) | 10.0 | 90% | ACU | SAE J826 | No |
| 7 | 95% | 15.0 (380) | 10.0 | 90% | ENC | SAE J826 | No |
| 8 | 90% | 15.0 (380) | 10.0 | 50% | PPE | SAE J826 | No |
| 9 | 90% | 15.0 (380) | 10.0 | 50% | ACU | SAE J826 | No |
| 10 | 90% | 15.0 (380) | 10.0 | 50% | ENC | SAE J826 | Yes |

5.3 Planned Verification Reporting

The Fixed Seat: Non-Driver CAD model verification effort will produce a verification report that captures the results of the activities completed per this verification plan. Any areas that do not meet the defined verification acceptability requirements will be reviewed and a path forward will be provided to correct the issue.

6. KEY PARTICIPANTS

Table 7 identifies the participants involved in the VV&A effort including the roles and responsibilities.

Table 7: Key Participants for FHP Accommodation Model VV&A

| VV&A Function | Description | Responsible M&S |
|---|---|---|
| Accreditation Authority | Organization/individual who approves the use of an M&S for a particular application. The accreditation authority represents the M&S User's interests. The Accreditation Authority is a Government entity. | Director, ARL HRED |
| Accreditation Agent | Individual, group, or organization designated by the Accreditation Authority to conduct an accreditation assessment for an M&S | ARL HRED / TARDEC ACT |
| Accreditation Team / Subject Matter Experts (SMEs) | Participants involved in the accreditation effort and individual who, by virtue of education, training, or experience, has expertise in a particular technical or operational discipline, system, or process. | Cheryl A. Burns, ARL HRED David A. Hullinger, ARL HRED TACOM FE Joseph R. Urda, ARL HRED TACOM FE Frank J. Huston II, TARDEC ACT Gale L. Zielinski, TARDEC ACT Richard W. Kozycki, ARL HRED |
| M&S Proponent | The organization that has primary responsibility for M&S planning and management that includes development, verification and validation, configuration management, maintenance, use of the model or simulation, and others as appropriate. A Government entity. | Frank J. Huston II, TARDEC ACT Gale. L. Zielinski, TARDEC ACT |
| M&S User | The individual, group, or organization that uses the results or products from a specific application of the model or simulation. | TARDEC ACT TARDEC CSI Gale M. Litrichin, TARDEC GVSP ARL HRED Government Contractors |
| Validation Agent | The organization designated by the M&S proponent to perform validation of a model, simulation, or federation of M&S. | Cheryl A. Burns, ARL HRED David A. Hullinger, ARL HRED TACOM FE Joseph R. Urda, ARL HRED TACOM FE Richard W. Kozycki, ARL HRED |
| Verification Agent | The organization designated by the M&S proponent to perform verification of a model, simulation, or federation of M&S. | Frank J. Huston II, TARDEC ACT Gale L. Zielinski, TARDEC ACT |
| M&S Developer | The individual, group or organization responsible for developing or modifying a model or simulation in accordance with a set of design requirements and specifications. | Frank J. Huston II, TARDEC ACT Matthew P. Reed, Ph.D, UMTRI |
| SMEs | Individual who, by virtue of education, training, or experience, has expertise in a particular technical or operational discipline, system, or process. | Frank J. Huston II, TARDEC ACT Gale L. Zielinski, TARDEC ACT Cheryl A. Burns, ARL HRED Richard W. Kozycki, ARL HRED Joseph R. Urda, ARL HRED David A. Hullinger, ARL HRED Brian D. Corner, PhD, MERS - SIAT Matthew P. Reed, Ph.D, UMTRI |

7. PLANNED VERIFICATION RESOURCES

7.1 Verification Resource Requirements

SMEs to support the verification effort are defined above in Table 7. SMEs are included from Marine Expeditionary Rifle Squad (MERS), ARL HRED, TARDEC, and UMTRI.

7.2 Verification Milestones and Timeline

The proposed verification schedule is provided. Dates may change as the program changes.

Table 8: Fixed Seat: Non-Driver Accommodation Model V&V Schedule

| Event/ Activity / Milestone (Responsible) | End |
|--|------------|
| Final Verification Plan (TARDEC ACT) | 3QFY18 |
| Draft Version of Fixed Seat: Non-Driver CAD Model (TARDEC ACT) | 4QFY18 |
| Final Version of Fixed Seat: Non-Driver CAD Model (TARDEC ACT) | 1QFY19 |
| Verification of Fixed Seat: Non-Driver CAD Model (TARDEC ACT) | 2QFY19 |
| Fixed Seat: Non-Driver CAD Model User Guide (TARDEC ACT) | 3QFY19 |
| Transition Fixed Seat: Non-Driver CAD Model (TARDEC ACT) | 3QFY19 |
| Final Verification Report (TARDEC ACT) | 3QFY19 |

8. Appendices

8.1 Appendix A – References

- Department of Defense. (2008). Standard Practice – Documentation of Verification, Validation, and Accreditation (VV&A) for Models and Simulations. Alexandria, VA. (MIL-STD-3022).
- Department of Defense. (2012). Design Criteria Standard – Human Engineering. Redstone Arsenal, AL. (MIL-STD 1472G).
- McNamara, J. (2012). *Soldier Load Configuration in Ground Vehicles*. DTIC Technical Report No. 23726, U.S. Army Natick Research, Development and Engineering Center, Natick, MA.
- Reed, M., and Ebert, S. (2014). *Evaluation of the Seat Index Point Tool for Military Seats*. Report No. UMTRI-2014-33. Ann Arbor, MI. University of Michigan Transportation Research Institute. Retrieved from <https://deepblue.lib.umich.edu/handle/2027.42/111823>.
- Reed, M. (2016). *Seated Soldier Elbow Clearance Zones*. University of Michigan Transportation Research Institute, Ann Arbor, MI.
- Reed, M., and Ebert, S. (2013). *The Seated Soldier Study: Posture and Body Shape in Vehicle Seats*. Report No. UMTRI-2013-13. University of Michigan Transportation Research Institute, Ann Arbor, MI. Retrieved from <https://deepblue.lib.umich.edu/handle/2027.42/109725>.
- Zerehsaz, Y., Ebert, S., and Reed, M. (2014). Development of Accommodation Models for Soldiers in Vehicles: Squad. Report No. UMTRI-2014-39. University of Michigan Transportation Research Institute, Ann Arbor, MI. Retrieved from <https://deepblue.lib.umich.edu/handle/2027.42/120917>.
- Reed, M. (2013). Seated Soldier Posture Prediction 2013-11-30 [Microsoft Excel Spread Sheet]. MI: University of Michigan Transportation Research Institute.
- Reed, M. (2015). Soldier Squad Accommodation Models 2016-02-22 [Microsoft Excel Spread Sheet]. MI: University of Michigan Transportation Research Institute.
- Zielinski, G., Huston II, F., Kozycki, R., Kouba, R., and Wodzinski, C. (2015). Introduction to Boundary Manikins and Accommodation Models for Military Ground Vehicle Occupant Centric Design. DTIC Technical Report TR-26516. U.S. Army Tank Automotive Research, Development, and Engineering Center, Warren, MI.

8.2 Appendix B – Acronyms

| | |
|-----------------|---|
| ACH | Advanced Combat Helmet |
| ACT | Advanced Concepts Team |
| ACU | Advanced Combat Uniform |
| ANSUR | Army Anthropometric Survey |
| ARL HRED | Army Research Laboratory Human Research and Engineering Directorate |
| ATV | All-Terrain Vehicle |
| CAD | Computer-Aided Design |
| COTS | Commercial Off-The-Shelf |
| CSI | Center for System Integration |
| EMD | Engineering Manufacturing and Development |
| ENC | Encumbered |
| ESAPI | Enhanced Small Arms Protective Insert |
| ESBI | Enhanced Side Ballistic Inserts |
| FE | Field Element |
| FOV | Field-of-View |
| GVSP | Ground Vehicle Survivability and Protection |
| HARP | Human Accommodation Reference Point |
| HFE | Human Factors Engineering |
| HSI | Human Systems Integration |
| ICV | Infantry Carrier Vehicle |
| IFV | Infantry Fighting Vehicle |
| IOTV | Improved Outer Tactical Vest |
| MCoE | Maneuver Center of Excellence |
| MERS | Marine Expeditionary Rifle Squad |
| MRAP | Mine Resistant Ambush Protected |
| MS | Milestone |
| M&S | Modeling and Simulation |
| NSRDEC | Natick Soldier Research Development and Engineering Center |
| PPE | Personal Protective Equipment |
| SAW | Squad Automatic Weapon |
| SIAT | System Engineering, Interoperability, Architecture & Technology |
| SIP | Seat Index Point |
| SME | Subject Matter Experts |
| TAP | Tactical Assault Panel |
| TACOM | Tank Automotive Command |
| TARDEC | Tank Automotive Research, Development, and Engineering Center |
| UMTRI | University of Michigan Transportation Research Institute |
| V&V | Verification and Validation |

8.3 Appendix C – Distribution List

US Army Tank Automotive Research, Development, and Engineering Center (TARDEC):

- Gale L. Zielinski, Mechanical Engineer/Advanced Concepts Team (ACT), RDECOM-TARDEC, Warren, MI 48397-5000, E-Mail: gale.l.zielinski.civ@mail.mil
- Frank J. Huston II, Mechanical Engineer/ACT, RDECOM-TARDEC, Warren, MI 48397-5000, E-Mail: frank.j.huston.civ@mail.mil
- Russell D. Kouba, Team Leader/ ACT, RDECOM-TARDEC, Warren, MI 48397-5000, E-Mail: russell.d.kouba.civ@mail.mil
- Gale M. Litrichin, Principal Seat Engineer – Interior Blast Mitigation Team (IBMT)/Ground Vehicle Survivability and Protection (GVSP), RDECOM-TARDEC, Warren MI 48397-5000, E-Mail: gale.m.litrichin.civ@mail.mil
- Eric S. Paternoster, CSI Systems Integration Team, RDECOM-TARDEC, Warren MI 48397-5000, E-Mail: eric.s.paternoster2.civ@mail.mil

Army Research Laboratory (ARL) Human Research and Engineering Directorate (HRED):

- Richard W. Kozycki, ARL HRED, RDRL-HRM-B, Aberdeen Proving Ground, MD 21005-5425, E-Mail: richard.w.kozycki.civ@mail.mil
- Cheryl A. Burns, ARL HRED, RDRL-HRM-H, Fort Knox, KY 40121, E-Mail: cheryl.a.burns12.civ@mail.mil
- David A. Hullinger, Human Factors Engineer, ARL HRED – TACOM Field Element, RDRL-HRM-CU, Warren, MI 48397-5000, E-Mail: david.a.hullinger.civ@mail.mil
- Joseph R. Urda, Human Factors Engineer, ARL HRED – TACOM Field , TACOM Field Element, RDRL-HRM-CU, Warren, MI 48397-5000, E-Mail: joseph.r.urda.civ@mail.mil

US Army Natick Soldier Research, Development, and Engineering Center (NSRDEC):

- Steven Paquette, Anthropology Team Leader, NSRDEC, Natick, MA 01760, E-Mail: steven.p.paquette.civ@mail.mil
- Joseph L. Parham, Research Anthropologist, NSRDEC, Natick, MA 01760, E-Mail: joseph.l.parham2.civ@mail.mil
- Dawn L. Woods, Human Factors Engineer, NSRDEC, Natick, MA 01760, E-Mail: dawn.l.woods6.civ@mail.mil

Maneuver Center of Excellence (MCoE):

- Gustave R. Steenborg, Systems Safety Engineer, Mounted Requirements Division Capabilities Development and Integration Directorate MCoE, Fort Benning, GA 31905, E-Mail: gustave.r.steenborg.civ@mail.mil

Marine Expeditionary Rifle Squad (MERS):

- Brian D. Corner, PhD., Research Anthropologist, Systems Engineering, Interoperability, Architectures & Technology (SIAT), E-Mail: brian.corner@usmc.mil

Naval Surface Warfare Center – Warfare Systems Department:

- Brian Keeven, Engineer - Human System Integration, Dahlgren, VA 22448, E-Mail: brian.keeven@navy.mil

Air Force

- Jennifer J. Whitestone, Biomedical Engineer, Air Force Life Cycle Management Center (AFLCMC)/WNU, Wright-Patterson Air Force Base (WPAFB), OH 45433-7017, E-Mail: jennifer.whitestone@us.af.mil
- Jeffrey A. Hudson, PhD., Biological Anthropologist, U.S. Air Force (USAF) Cockpit/Crewstation Accommodation SME, Infoscitex, E-Mail: jhudson@infoscitex.com

University of Michigan Transportation Research Institute (UMTRI):

- Matthew P. Reed, PhD., Research Professor and Head Biosciences Group, UMTRI, Ann Arbor, MI 48109-2150, E-Mail: mreed@umich.edu