



**NAVAL
POSTGRADUATE
SCHOOL**

MONTEREY, CALIFORNIA

THESIS

**MEDICAL BIOSENSORS CONNECTED TO A
SOFTWARE PLATFORM IN AN AUSTERE
ENVIRONMENT**

by

Köbie R. Smith

June 2019

Thesis Advisor:
Co-Advisor:

Alex Bordetsky
Steven J. Mullins

Approved for public release. Distribution is unlimited.

THIS PAGE INTENTIONALLY LEFT BLANK

REPORT DOCUMENTATION PAGE			<i>Form Approved OMB No. 0704-0188</i>	
Public reporting burden for this collection of information is estimated to average 1 hour per response, including the time for reviewing instruction, searching existing data sources, gathering and maintaining the data needed, and completing and reviewing the collection of information. Send comments regarding this burden estimate or any other aspect of this collection of information, including suggestions for reducing this burden, to Washington headquarters Services, Directorate for Information Operations and Reports, 1215 Jefferson Davis Highway, Suite 1204, Arlington, VA 22202-4302, and to the Office of Management and Budget, Paperwork Reduction Project (0704-0188) Washington, DC 20503.				
1. AGENCY USE ONLY (Leave blank)		2. REPORT DATE June 2019	3. REPORT TYPE AND DATES COVERED Master's thesis	
4. TITLE AND SUBTITLE MEDICAL BIOSENSORS CONNECTED TO A SOFTWARE PLATFORM IN AN AUSTERE ENVIRONMENT			5. FUNDING NUMBERS	
6. AUTHOR(S) Köbie R. Smith				
7. PERFORMING ORGANIZATION NAME(S) AND ADDRESS(ES) Naval Postgraduate School Monterey, CA 93943-5000			8. PERFORMING ORGANIZATION REPORT NUMBER	
9. SPONSORING / MONITORING AGENCY NAME(S) AND ADDRESS(ES) N/A			10. SPONSORING / MONITORING AGENCY REPORT NUMBER	
11. SUPPLEMENTARY NOTES The views expressed in this thesis are those of the author and do not reflect the official policy or position of the Department of Defense or the U.S. Government.				
12a. DISTRIBUTION / AVAILABILITY STATEMENT Approved for public release. Distribution is unlimited.			12b. DISTRIBUTION CODE A	
13. ABSTRACT (maximum 200 words) In this thesis, we evaluate the integration of commercial-off-the-shelf (COTS) physiological biosensors with a software platform application, Battlefield Assisted Trauma Distribution Kit (BATDOK), in a field environment using a Mobile Ad Hoc Network (MANET). Navy corpsmen, while deployed with the Marine Corps, can expect to find themselves in an austere or network-contested environment with limited network capability. They may need to monitor more than one casualty at a time and relay the information to a higher echelon of care in real time. The 2016 <i>Marine Corps Operating Concept</i> states to “take advantage of commercial-off-the-shelf (COTS) network and data solutions” and to “operate with Resilience in a Contested-Network Environment.” Research was performed iteratively, from selection and configuration of equipment, biosensors, and software to field experiments with various objectives. The quantitative analysis of the experiment data showed that the use of a MANET worked well to transmit data in an austere and network-contested environment. Based on this research, it was found that BATDOK is a feasible solution to capture patient data from COTS biosensors, but additional experimentation must be completed with more biosensors and different operational environments to determine its true efficacy during military operations in which corpsmen may find themselves.				
14. SUBJECT TERMS Mobile Ad Hoc Network, MANET, self-healing, self-forming, mesh network, tactical network, battlefield medicine, austere environment, Battlefield Assisted Trauma Distributed Observation Kit, BATDOK, physiological biosensors			15. NUMBER OF PAGES 103	
			16. PRICE CODE	
17. SECURITY CLASSIFICATION OF REPORT Unclassified	18. SECURITY CLASSIFICATION OF THIS PAGE Unclassified	19. SECURITY CLASSIFICATION OF ABSTRACT Unclassified	20. LIMITATION OF ABSTRACT UU	

THIS PAGE INTENTIONALLY LEFT BLANK

Approved for public release. Distribution is unlimited.

**MEDICAL BIOSENSORS CONNECTED TO A SOFTWARE PLATFORM IN AN
AUSTERE ENVIRONMENT**

Köbie R. Smith
Lieutenant, United States Navy
BS, Southern Illinois University at Carbondale, 2009

Submitted in partial fulfillment of the
requirements for the degree of

MASTER OF SCIENCE IN NETWORK OPERATIONS AND TECHNOLOGY

from the

**NAVAL POSTGRADUATE SCHOOL
June 2019**

Approved by: Alex Bordetsky
Advisor

Steven J. Mullins
Co-Advisor

Dan C. Boger
Chair, Department of Information Sciences

THIS PAGE INTENTIONALLY LEFT BLANK

ABSTRACT

In this thesis, we evaluate the integration of commercial-off-the-shelf (COTS) physiological biosensors with a software platform application, Battlefield Assisted Trauma Distribution Kit (BATDOK), in a field environment using a Mobile Ad Hoc Network (MANET). Navy corpsmen, while deployed with the Marine Corps, can expect to find themselves in an austere or network-contested environment with limited network capability. They may need to monitor more than one casualty at a time and relay the information to a higher echelon of care in real time. The 2016 *Marine Corps Operating Concept* states to “take advantage of commercial-off-the-shelf (COTS) network and data solutions” and to “operate with Resilience in a Contested-Network Environment.” Research was performed iteratively, from selection and configuration of equipment, biosensors, and software to field experiments with various objectives. The quantitative analysis of the experiment data showed that the use of a MANET worked well to transmit data in an austere and network-contested environment. Based on this research, it was found that BATDOK is a feasible solution to capture patient data from COTS biosensors, but additional experimentation must be completed with more biosensors and different operational environments to determine its true efficacy during military operations in which corpsmen may find themselves.

THIS PAGE INTENTIONALLY LEFT BLANK

TABLE OF CONTENTS

I.	INTRODUCTION.....	1
A.	PROBLEM STATEMENT	3
B.	RESEARCH QUESTIONS.....	3
C.	SCOPE AND LIMITATIONS.....	4
D.	ORGANIZATION OF THESIS	5
II.	LITERATURE REVIEW	7
A.	OPERATIONAL CONTEXT.....	7
B.	REQUIREMENTS EMERGING FROM THE OPERATIONAL CONTEXT	8
1.	System Requirement—Mobility.....	8
2.	System Requirement—Power	9
3.	User Requirements	10
4.	Operational Requirements.....	12
5.	Data Documentation Requirements	13
6.	Networking Requirements	15
C.	COMMON BIOSENSOR ARCHITECTURE	15
D.	MONITORING SYSTEM	16
E.	SOFTWARE PLATFORM SOLUTION.....	19
F.	OSI MODEL CONSIDERATIONS	21
G.	WIRELESS COMMUNICATIONS.....	22
1.	Wireless Personal Area Network.....	23
2.	Mobile Adhoc Network (MANET).....	23
3.	Bluetooth Networking.....	25
III.	EXPERIMENT METHODOLOGY	31
A.	PHASE 0: SELECTION OF EQUIPMENT, BIOSENSORS, AND SOFTWARE	32
1.	Equipment.....	32
2.	Biosensors.....	38
3.	Software	42
B.	PHASE I: EXPERIMENT CONFIGURATION	47
1.	Actions.....	47
2.	Observations.....	49
C.	PHASE II: LINE-OF-SIGHT TESTING	50
1.	Objective	50
2.	Actions.....	51

3.	Observations.....	54
D.	PHASE III: BLOS TESTING.....	60
1.	Objective.....	61
2.	Actions.....	61
3.	Observations.....	62
E.	PHASE IV: DISCOVERY IN A MESH NETWORK.....	63
1.	Objective.....	63
2.	Actions.....	64
3.	Observations.....	65
F.	PHASE V: INCREASED DISTANCE OF A MESH NETWORK.....	69
1.	Objective.....	69
2.	Actions.....	70
3.	Observations.....	71
IV.	ANALYSIS.....	73
A.	LOS TESTING.....	73
B.	BLOS TESTING.....	73
C.	MESH NETWORK.....	74
D.	NETWORK THROUGHPUT AND SNR CONCLUSIONS.....	74
E.	RESEARCH QUESTIONS.....	75
V.	CONCLUSIONS AND FUTURE RECOMMENDATIONS.....	77
A.	SIGNIFICANCE.....	77
B.	LIMITATIONS.....	77
C.	FUTURE WORK.....	78
	LIST OF REFERENCES.....	79
	INITIAL DISTRIBUTION LIST.....	83

LIST OF FIGURES

Figure 1.	DD Form 1380. Source: ESD (2014).....	14
Figure 2.	Prehospital Injury Documentation in Combat. Source: Eastridge et al. (2011).....	15
Figure 3.	Common Architecture for Biosensor Monitoring. Source: Buller (2010).....	16
Figure 4.	EQ01 (top) and EQ02 (bottom). Source: Friedl et al. (2016).	17
Figure 5.	Concept of Sensor Integration. Source: Hirschberg et al. (2016).	19
Figure 6.	BATDOK’s Primary Screen.	20
Figure 7.	Screenshot of DD Form 1380 PDF from BATDOK	21
Figure 8.	OSI Model. Source: Westcott and Coleman (2014).	22
Figure 9.	MANET Backbone for a MTX Networking Experiment. Source: Bordetsky (2018).	25
Figure 10.	Bluetooth Piconet Example. Source: Ferro and Potorti (2005)	26
Figure 11.	Bluetooth Stack within the OSI Model. Source: Ferro (2015).	28
Figure 12.	Experiment Plan	32
Figure 13.	MPU4 with Optional 10/100 Ethernet Connection.....	33
Figure 14.	MPU5 with an Ethernet Connector and 3 RF Antennas	34
Figure 15.	Galaxy S5 (left), Galaxy S9+ (middle), and ST85 (right).	36
Figure 16.	Raspberry Pi with External Battery	37
Figure 17.	BATDOK Demonstration Sensor Selection (top) and Showing Vitals (bottom).....	39
Figure 18.	Masimo MightySat	40
Figure 19.	Polar H10 Heart Rate Sensor. Adapted from Polar (n.d.b).....	41
Figure 20.	Polar H10	41
Figure 21.	SolarWinds SNMP Real-Time Graph.....	43

Figure 22.	SolarWinds Bandwidth Gauge.....	44
Figure 23.	Persistent Systems Wave Relay Management Interface.....	45
Figure 24.	Node Pinger Program.....	46
Figure 25.	Initial Setup and Configuration of NOC and Corpsman.....	47
Figure 26.	MPU4 Connected to the SNMP Agent via Wi-Fi without the 10/100 Ethernet Cable.....	48
Figure 27.	Nodes and Distances.....	50
Figure 28.	Roof of Spanagel Hall.....	51
Figure 29.	Two Patients Displayed in BATDOK on the Samsung S9+ Smartphone	52
Figure 30.	Flow of Network Information.....	53
Figure 31.	MPU4, SNMP Agent and Battery (left) and MPU5 (right) with the Corpsman	54
Figure 32.	Polar H10 Plugin Error Message	55
Figure 33.	LOS Test–Network Throughput at the HM MPU4	56
Figure 34.	Pictures Attached to Patients	57
Figure 35.	Vital Signs Received on the NOC BATDOK.....	58
Figure 36.	SNR from the HM MPU4 LOS Test.....	59
Figure 37.	SNR from the HM MPU4 with the MightySat	59
Figure 38.	MightySat Vital Signs Visible at the NOC	60
Figure 39.	BLOS Testing	60
Figure 40.	View from MPU4 Locations.....	61
Figure 41.	BLOS Test Network Throughput.....	62
Figure 42.	SNR from the HM MPU4 during BLOS Test	63
Figure 43.	Phase IV MPU4 Locations.....	64
Figure 44.	MPU4 Relay Node.....	65

Figure 45.	SNR from Relay MPU4	66
Figure 46.	Mesh Test Network Throughput.....	67
Figure 47.	Mesh Test Network Throughput of 10 Pictures.....	68
Figure 48.	SNR from the Relay MPU4 to End Nodes	68
Figure 49.	Locations of MPU5 Nodes.....	69
Figure 50.	MPU5 Bundle (MPU5, External Battery, and Raspberry Pi).....	70
Figure 51.	Node Ping Graph of the MPU5s and SNMP Agents	71

THIS PAGE INTENTIONALLY LEFT BLANK

LIST OF TABLES

Table 1.	USARIEM VSDS Study Description. Adapted from Tharion et al. (2010).....	11
Table 2.	VSDS Acceptability Percentage. Adapted from Tharion et al. (2010).....	12
Table 3.	Bluetooth Characteristics. Adapted from Baker (2005).	27
Table 4.	MPU4 and MPU5 Radio Specifications. Adapted from Persistent Systems (2016) and Persistent Systems (2017).	35
Table 5.	Information Collected by the SNMP Agent.....	49
Table 6.	BATDOK Names and Corresponding Sensors.....	53
Table 7.	Maximum Kbps Achieved through the HM MPU4 during Tests.....	75

THIS PAGE INTENTIONALLY LEFT BLANK

LIST OF ACRONYMS AND ABBREVIATIONS

3G	Third Generation Wireless Cellular Service
4G	Fourth Generation Wireless Cellular Service
BATDOK	Battlefield Assisted Trauma Distributed Observation Kit
CENETIX	Center for Network Innovation and Experimentation
COTS	Commercial off-the-shelf
FHSS	Frequency-Hopping Spread Spectrum
GPS	Global Positioning System
IEEE	Institute of Electrical and Electronics Engineers
IP	Internet Protocol
LOS	Line of Sight
LTE	Long Term Evolution
MAC	Media Access Control
MANET	Mobile Ad Hoc Network
MIB	Management Information Base
MLB	Motor Life Boat
MOC	Marine Corps Operating Concept
MPU4	Man Portable Unit 4 th Generation
MPU5	Man Portable Unite 5 th Generation
NOC	Network Operating Center
NPS	Naval Postgraduate School
OS	Operating System
OSI	Open System Interconnection
PDF	Portable Document Format
PPE	Personnel Protective Equipment
RF	Radio Frequency
RTG	Real-Time Graph
SNMP	Simple Network Management Protocol
SSID	Service Set Identifier
SNR	Signal-to-Noise Ratio
TCCC	Tactical Combat Casualty Care

UAV	Unmanned Aerial Vehicle
UWB	Ultra Wideband
VSDS	Vital Sign Detection System
Wi-Fi	Wireless Fidelity
WPAN	Wireless Personal Area Network

ACKNOWLEDGMENTS

I would like to acknowledge the NPS CENETIX team; Dr. Alex Bordetsky, Steve Mullins, and Eugene Bourakov; Dr. Bordetsky for your overall guidance, Steve Mullins for keeping me on track, and Eugene Bourakov for assisting me with the experiments.

Most of all, I want to thank my wife, Summer, for her encouragement and patience throughout my time at NPS. You allowed me to focus on school during these past two years and I could not have accomplished what I did without your support. You are the best!

THIS PAGE INTENTIONALLY LEFT BLANK

I. INTRODUCTION

A U.S. Wasp-class amphibious assault ship is patrolling in the South China Sea. A squad, consisting of Marines and a corpsman, has been deployed to an island for reconnaissance. They are patrolling inland while maintaining communications with the ship a few miles offshore via a tactical radio: a Man Portable Unit 4 (MPU4). Each squad member has a MPU4 radio and a smart device, either a smartphone or tablet, with which the squad is able to communicate with one another and with the ship within their own mobile ad hoc network (MANET). While patrolling, the squad is ambushed and suffers several casualties with injuries of differing severity. To safeguard against losing vital patient and treatment information, the squad's corpsman must treat, document, and relay health status of his team members and to the ship, where a higher echelon of care is located with a full medical department. The number of casualties exceeds his ability to efficiently monitor and treat everyone at the same time.

However, the corpsman has a tool at his disposal to help manage the situation. The corpsman and fellow squad members have a smart device configured with a software platform application that integrates medical biosensors, delivers information across the mesh network, and gives an overview of medical readiness in the operational situation. It allows the corpsman to monitor vital signs and document all medical interventions performed on each of the injured personnel. Each squad member and the ship's medical department are able to view the same biometric information synchronously, which is auto-populated within the MANET. During casualty treatment, the corpsman uses several commercial-off-the-shelf (COTS) medical biosensors that wirelessly input health information to the smart device through the application, allowing the ship's medical department to maintain robust awareness of the status of the casualties, any treatment rendered, proactively warn the corpsman if any of the Marines' vital signs indicate problems, prepare for casualty evacuations.

This thesis proposes that the future of battlefield medicine is in the use of physiological biosensors to monitor patient status, even in austere environments; thus, reliable biosensors and monitoring applications can be expected in future use by fielded

forces. Currently, the Air Force's 711 Human Performance Wing has developed an android mobile operating system (OS) compatible application, the Battlefield Assisted Trauma Distributed Observation Kit (BATDOK), to connect and display vital signs from biosensors in real time to increase medical situational awareness (Burnett, Bragg, Feibus, & Mack, 2018). However, BATDOK introduces two unknowns: 1) how large file sizes can be before the network bogs down and 2) what the optimal throughput of data is for the BATDOK application (D. J. Feibus, personal communication, December 6, 2018). In 2016, a Naval Postgraduate School (NPS) thesis by Montgomery and Anderson experimented with biosensors and reachback capability from a shipboard perspective and concluded that an application capable of collecting data from multiple COTS biomedical sensors in a field environment would require further evaluation and experimentation (Montgomery & Anderson, 2016).

Another NPS thesis in 2012 by E. A. Miles focused a capstone project on a casualty network system. Miles identified a handoff problem in the theatre of operations in which minimal communication of patient information, verbally and through the manual use of a TCCC card, could lead to significant gaps in continuity of care (Miles, 2012). The thesis recommended an experiment of the casualty network system and he stated "the objective of the experiment process will be to use current COTS products to pass casualty information over currently used tactical networks" (Miles, 2012, p. 25). Both of the research threads above provided the motivation for this work.

Therefore, this thesis studies whether it is feasible to capture signals from multiple COTS biosensors in one application, and examines a software platform's efficacy within a MANET. I conducted a series of experiments using BATDOK to monitor and capture biosensor information, analyze the results, and assess the feasibility of using one application to monitor multiple biosensors. The research results should benefit Navy hospital corpsmen, Army combat medics, and Air Force medics by improving lifesaving actions.

A. PROBLEM STATEMENT

The 2016 Marine Corps Operating Concept (MOC) identifies critical tasks, issue areas, and ways to improve the future force; among them are “Take advantage of commercial-off-the-shelf (COTS) network and data solutions” and “Operate with Resilience in a Contested-Network Environment” (United States Marine Corps [USMC], 2016, p. 14, 17). Navy corpsmen, while deployed with the Marine Corps, can expect to find themselves in an austere or contested-network environment with limited network capability. They may need to monitor more than one casualty patient at a time and relay the information to a higher echelon of care in real time. Sailors, Soldiers, Airmen, and Marines can die from injuries sustained in training or combat if the corpsman or medic becomes overwhelmed. Following Montgomery and Anderson, what is urgently needed is a means to bridge the gap from monitoring one biosensor at one time, each on its own unique application, to employing multiple biosensors on multiple patients within one application to expand the use of biosensors in a tactical environment via a MANET and increase survivability of casualties in the field (Montgomery & Anderson, 2016).

B. RESEARCH QUESTIONS

The purpose of this thesis is to analyze the ability of BATDOK with a goal of improving the monitoring and mortality rate of injured personnel in austere environments. The research questions to be answered are as follow:

- What factors affect BATDOK’s ability to process data from multiple biosensors?
- What factors affect data flow using BATDOK?
- How does an influx of patient data affect MANET throughput?
- How can a software platform solution within a MANET improve the monitoring and mortality rate of injured personnel in an austere environment?

C. SCOPE AND LIMITATIONS

This thesis focuses on exploring the connectivity of COTS biosensors to one specific application (BATDOK) and the distribution of health information in a MANET. This connectivity encompasses biosensors, the software application, smart devices. Communication in a MANET occurs through several nodes relaying information in a mesh network.

The biosensor data collected and distributed in the experimentation load the mesh network with data to determine the efficacy and adaptability of using one application to deliver information between a squad and a remote medical unit in an austere environment. Urban or shipboard scenarios are beyond the scope of this study.

This thesis is limited in the terms of software, devices, and wireless communication used for study:

- The software platform chosen integrates with multiple sensors and transmits their data using different wireless protocols. Due to time, funding, and integration constraints, some compatible COTS biosensors are not investigated; the Masimo EMMA Capnograph carbon dioxide monitor, Nonin Onyx II fingertip pulse oximeter, Zephyr BioHarness 3 physiological monitoring device, and Athena GTX wireless vital signs monitor. The Masimo MightySat fingertip pulse oximeter, Polar H10 heartrate monitor, and selected demonstration sensors are used. The demonstration sensors simulate various vital signs normally captured by COTS sensors.
- Although vital signs are among the data collected and transmitted, the scope of the thesis is not to investigate the accuracy of the biosensors but to analyze the data throughput within a MANET.
- For tactical relevance, this thesis employs wireless fidelity (Wi-Fi) on tactical radios and a mesh network to simulate limited connectivity in an austere environment. Various network technologies not relevant to this research include Long-term Evolution (LTE) cellular network, Peer-to-Peer

(P2P), Universal Data Packet (UDP), Transmission Control Protocol/Internet Protocol (TCP-IP), and goTenna Mesh network.

D. ORGANIZATION OF THESIS

The remainder of this thesis contains four chapters, which lay out the literature review, experimentation, and analysis and conclusions:

- Chapter II is a literature review covering prior work in the area(s) of wireless physiological monitoring, requirements, patient documentation, applicable network layers, wireless protocol communications, and reasoning behind use of an application that is able to capture health sensor information from different manufacturers and broadcast them across a mesh network
- Chapter III consists of the research methodology, including identification of equipment and software, configuration, and experimentation.
- Chapter IV is an analysis of the experimentation results.
- Chapter V provides conclusions and recommendations for future research.

THIS PAGE INTENTIONALLY LEFT BLANK

II. LITERATURE REVIEW

This chapter examines the literature on issues and areas of study related to capturing and transmitting patient information using biosensors. It begins with the operational context in which COTS biosensors will be employed, in line with the direction and the focus of the leadership of the Navy and Marine Corps, to protect the health and readiness of Sailors and Marines in austere environments. It then explains the wireless physiological monitoring system requirements. A wireless monitoring system used in a military field environment has different requirements than a system used in a hospital or clinical setting. The priorities are portability and user adoption. Next, it describes a software platform to monitor wireless physiological monitoring devices. Then, it examines the OSI model considerations in a MANET to explain which layers of the OSI model the biosensors are using to communicate. Lastly, it reviews the specifics of wireless communications as they pertain to this research.

A. OPERATIONAL CONTEXT

The following are the guiding documents which align this thesis with the leadership of the Navy and Marine Corps. The goal of military leadership is to ensure we have a trained and ready fighting force. In order for the forces to sustain themselves, they need to be ready and equipped to care for the injured in an expeditious and thorough manner in any operational environment. The Surgeon General of the Navy, Vice Admiral (VADM) C. Forrest Faison III, testified before the U.S. Senate Committee on Appropriations, in 2018, on the subject of the Defense Health Program, stating that Navy Medicine “protect(s) the health and readiness of Sailors and Marines so they are medically read to meet their missions” and “readiness and combat support remain our number one priority and mission” (*Review of the FY2019 Budget*, 2018). My analysis of VADM Faison’s statements is that corpsmen must be ready to support Sailors and Marines during any missions, whether at sea or on land in an austere environment.

The operational context in which our missions are to be executed is changing, particularly in the realm of technology: there will likely come times when U.S. military forces find themselves in austere network environments and must be able to communicate and transmit data without conventional means of communication, such as third and fourth

generation cellular data networks (3G; 4G) and Long Term Evolution (LTE). In response to recent developments, the 2018 *Nation Defense Strategy* of the United States of America requires modernizing key capabilities and “also invest in cyber defense, resilience, and the continued integration of cyber capabilities into the full spectrum of military operations” (DoD, 2018). Likewise, the MOC states “We must be an *Expeditionary Force* that is trained and equipped and able to operate in austere conditions and hostile environments,” (United States Marine Corps, 2016, p. 4) such as a small squad attempting to maintain a small communication footprint with reduced communications.

Although the MOC does not address it directly, it is clear that hospital corpsmen must also therefore be prepared to tend to casualties in austere conditions and hostile environments. To perform this task, the Navy and Marine Corps team must be able to operate MANETs that allow communication and data flow via standalone networks that are mobile, self-healing, and self-forming. Corpsmen deployed with their squads must also be ready to treat patients and share information in a MANET if the situation calls for it. A corpsman may be the only medical person embedded with a small team, may only have a few wireless biosensors at his disposal, and must be prepared to share the team’s medical status externally. This is increasingly important in the operational environments outlined in the MOC.

B. REQUIREMENTS EMERGING FROM THE OPERATIONAL CONTEXT

Based on this operational context, there are several requirements for the corpsman’s COTS system: System Requirements, User Requirements, Operational Requirements, and Data Documentation Requirements.

1. System Requirement—Mobility

The military operational user requirements differ from hospital and home health requirements in that the military has an emphasis on mobility. “Reduced size, weight, and power is critical to soldier acceptability” (Friedl, 2018). The physiological monitoring system must be as unobtrusive as possible. Wireless sensor communications are thus more suitable to military applications than wired sensors because of the necessary mobility and personnel protective equipment (PPE) requirements. A continuous monitoring system must be able to

blend in and fit underneath layers of PPE, including body armor, if the situation warrants it (Hirschberg et al. 2016).

The first considerations are size and weight because mobility is important in a field environment. It is most likely that a corpsman will be the individual in a squad carrying the medical gear. That said, there are two possible arrangements, 1) the corpsman carries multiple sensors to treat patients or 2) each squad member carries or wears his own physiological monitoring system. The squad, except the corpsman, gains speed and comfort without wearing an individual physiological monitoring system, until such time as a member is injured.

A casualty may be too far away to place a biosensor on and if the squad member was already wearing a monitoring system, the corpsman may be able to monitor his vital signs from afar. That said, the corpsman carrying a few sensors that perform simple readings of physiological signs rather than each squad member wearing a cumbersome monitoring system that captures everything may be more acceptable to a squad traveling a long distance on foot. Depending on the specific operation, there may be a limited number of options to carry extra equipment, especially on their person.

2. System Requirement—Power

A critical requirement is durable power. Electrical power is a precious commodity in an austere environment. Power is needed for communications, smart devices, flashlights, night vision goggles, and other important equipment. In the field, such devices are all powered by batteries. Biosensors in a physiological monitoring system must likewise use rechargeable power supplies or disposable batteries that are long-lasting and do not require replacement during the duration of an operation. A corpsman or medic may not be carrying extra disposable batteries or have a way to charge them when needed. Small portable solar recharging stations may not be useful because weather and the time of mission are seldom done in a perfect environment with 15 hours of sunlight. An auto-shutoff capability for biosensors or monitoring systems is therefore important. In addition, physical monitoring systems or sensors that can be added and removed from the network by an on and off or auto-off function would help to conserve power.

The Polar H10 heart rate monitor uses a changeable 3 Volt lithium battery (CR2025) and has a lifetime of approximately 400 hours (Polar, n.d.). The Masimo MightySat pulse oximeter uses common 1.5 Volt AAA batteries and its battery life is approximately 15 hours or 1,800 spot checks (Masimo, 2017). Each spot check is described as a 30 second reading with the display brightness set to 50% (Masimo, 2017).

The Athena GTX is a wired, or wireless, vital sign monitor that uses a rechargeable battery. The GTX lasts for approximately seven hours in battery mode and up to 15 hours in Low Power mode and takes approximately three and a half hours to fully charge (Athena GTX, 2018). The battery must be charged using a manufacturer supplied charger and cannot be replaced by the owner (Athena GTX, 2018). A rechargeable wireless vital sign monitor such as the GTX may not be as useful in an austere environment since a mission could last more than the battery will last if there is no opportunity to recharge the battery.

Because of a 24-hour battery life, the BioHarness may not be the best to use in an austere environment. Zephyr BioHarness 3, a chest strap type biosensor, uses a BioModule to capture specific vital signs. Power for the BioModule is a rechargeable lithium polymer, 3.4-4.2 Volt, battery and operates for 24 hours when new and fully charged (Zephyr, 2017). The service life of the battery is a minimum of 300 charges (Zephyr, 2017). Recharging of the battery requires an AC adapter, and 1 hour of charging will charge up to 90% capacity and 3 hours to 100% capacity (Zephyr, 2017). An operation may last more than 24 hours which would make the BioHarness useless unless multiple charged BioModules were carried during the operation.

Masimo Emma capnograph uses 1.5 Volt AAA alkaline or lithium batteries and each type of battery provides a different number of use hours: alkaline for 6 hours and lithium for 10 hours (Masimo, 2010). A capnograph is “a monitoring device that measures the concentration of carbon dioxide in exhaled air and displays a numerical readout and waveform tracing” (“Capnograph,” n.d.).

3. User Requirements

A major consideration is user requirements. Equipment is not good if users will not adopt and use it. An important user requirement for continuous monitoring is whether soldiers

accept it (Friedl, 2018). If a Sailor, or Marine, finds a piece of equipment or article of clothing uncomfortable, he will either wear it for a limited amount of time or not at all.

A study by Tharion, Buller, Karis, and Hoyt (2010) examined the wear and acceptability of the Hidalgo Equivital Vital Sign Detection System (VSDS). The Hidalgo Equivital VSDS is a chest-worn medical monitoring system, which integrates biosensors, processing, and networked communications to measure heart rate, respiratory rate, and skin temperature. The VSDS was worn by five Army personnel groups and four different versions were worn among them (Tharion et al., 2010). The Equivital VSDS is a similar concept to what is used in this thesis and it captures heart rate data, respiration rate, and skin temperature (Tharion et al., 2010). This technology was field-tested between 2006 and 2009 by the U.S. Army Research Institute of Environmental Medicine (USARIEM). There were four versions of the VSDS used in the study and they were designated EQ-01, EQ-02, EQ-03, and EQ-04 and developed iteratively. The groups of personnel, at different locations, were selected to wear a version of the VSDS for a certain number of hours while performing various mission tasks; shown in Table 1.

Table 1. USARIEM VSDS Study Description.
Adapted from Tharion et al. (2010).

VSDS Version #	Personnel and Study Duration	<i>n</i> ^a	Location
1	Infantry Soldiers Duration: 8 Hrs	8	Ft. Polk, LA
2	Infantry Soldiers Duration: 95 Hrs	26	Aberdeen Proving Grounds, MD
3	Civil Support Team - Weapons of Mass Destruction Duration: 4 Hrs	12	North Brookfield, MA
3	Ranger Training Brigade Students Duration: 4 Hrs	77	Ft. Benning, GA
4	Special Forces Students Duration: 90 Hrs	31	Camp McCall, NC

^aNumber of soldiers that participated in each group

The Soldiers were surveyed afterward on fit, comfort, impact on performance and body, and overall acceptability (Tharion et al., 2010), as in Table 2. For groups 1 and 2 an average of 43.5% found the VSDS acceptable to wear for an extended period of time, and groups 3, 4, and 5 accepted it at a much higher rate as shown in Table 2 (Tharion et al., 2010). Reasons from those who said they would not wear it were that they felt it would not actually help save their life and it was too uncomfortable to wear (Tharion et al., 2010). The soldiers in group 2 wore the system the longest, 95 hours, and groups 3 and 4 the shortest, 4 hours. The number of hours worn by each group may affect the soldier's acceptability percentages. The group that wore it for four hours may not have felt it uncomfortable for such a short period of time. A continuous physiological monitoring system may not be accepted by some users but individual biosensors may be more widely accepted.

Table 2. VSDS Acceptability Percentage.
Adapted from Tharion et al. (2010).

Group 1	Group 2	Group 3	Group 4	Group 5
VSDS Ver. 1 Ft. Polk	VSDS Ver. 2 Aberdeen	VSDS Ver. 3 North Brookfield	VSDS Ver. 3 Ft. Benning	VSDS Ver. 4 Camp McCall
Overall Acceptability of the System - Acceptable to Wear For Extended Periods of Time?				
50.0%	37.0%	91.7%	92.0%	83.9%

4. Operational Requirements

Researchers and manufacturers must also account for the geography, lack of IT infrastructure, distance, weather, and actions required during the operation as contributors to user acceptability. Mountainous terrain may make it difficult to transmit information within a MANET depending on the location of the nodes. If the primary reachback location is on top of a mountain and the rest of the nodes are below in a valley, then the MANET should work efficiently since there may be fewer obstructions. The opposite may be true

in an urban area. Interference and disruption of a MANET may be due to buildings and types of communication in the immediate area. The physiological monitoring system will have to withstand a variety of activities or have multiple configurations. Likewise, even though a system works well during a march on land, it may not work after being submerged in water.

5. Data Documentation Requirements

Casualties in austere environments are different from casualties in hospital settings. The resources available are very limited in austere environments. The corpsman may be very busy treating multiple patients, possibly overwhelmed, and his sole focus is on saving lives.

Instead of showing a snapshot(s) of vital signs, the ability to synchronously monitor a patient's trend in real time would allow the treating corpsman and the medical providers at a higher echelon of care to have a better understanding of what took place prior to the patient's arrival and observe how the patient physiologically responded to all interventions prior to arrival. Patient vital signs are recorded once, such as during a medical appointment, at specific intervals, or continuously depending on the reason for the interaction. An aspect of physiological monitoring is the ability to show trends in patient vital signs. The time between a casualty receiving care in the field and when they are actually evacuated to a higher echelon of care can take from minutes to hours. Vital signs are an important input for the treatment rendered while waiting during triage.

Pre-hospital documentation is important not only for the corpsman treating the casualties but also for the medical providers at the next echelon of care the patient may be evacuated to. Manual documentation of injuries, vital signs, and injuries in the battlefield can be accomplished using a Tactical Combat Casualty Care (TCCC) Card (DA Form 7656) (Kotal et al., 2013). DA Form 7656, from 2007, was updated to the Department of Defense Form 1380 (DD Form 1380) in 2014 (Executive Services Directorate [ESD], n.d.) as seen in Figure 1. There are additions to the updated version: mechanism of injury, tourniquet use, vital sign input, and evacuation priority. However, these forms/cards are limited of value and accuracy if not thoroughly completed or illegible.

TACTICAL COMBAT CASUALTY CARE (TCCC) CARD

BATTLE ROSTER #: _____
 EVAC: Urgent Priority Routine

NAME (Last, First): _____ LAST 4: _____
 GENDER: M F DATE (DD-MMM-YY): _____ TIME: _____
 SERVICE: _____ UNIT: _____ ALLERGIES: _____

Mechanism of Injury: (X all that apply)
 Artillery Blunt Burn Fall Grenade GSW IED
 Landmine MVC RPG Other: _____

Injury: (Mark injuries with an X)

TQ: R Arm

TYPE: _____

TIME: _____

TQ: L Arm

TYPE: _____

TIME: _____

TQ: R Leg

TYPE: _____

TIME: _____

TQ: L Leg

TYPE: _____

TIME: _____

Signs & Symptoms: (Fill in the blank)

	Time			
Pulse (Rate & Location)				
Blood Pressure	/	/	/	/
Respiratory Rate				
Pulse Ox % O2 Sat				
AVPU				
Pain Scale (0-10)				

DD Form 1380, JUN 2014 TCCC CARD

BATTLE ROSTER #: _____
 EVAC: Urgent Priority Routine

Treatments: (X all that apply, and fill in the blank) Type

C: TQ- Extremity Junctional Truncal _____
 Dressing- Hemostatic Pressure Other _____

A: Intact NPA CRIC ET-Tube SGA _____

B: O2 Needle-D Chest-Tube Chest-Seal _____

C:

	Name	Volume	Route	Time
Fluid				
Blood Product				

MEDS:

	Name	Dose	Route	Time
Analgesic (e.g., Fentanyl, Morphine)				
Antibiotic (e.g., Moxifloxacin, Ertapenem)				
Other (e.g., TXA)				

OTHER: Combat-Pill-Pack Eye-Shield (R L) Splint
 Hypothermia-Prevention Type: _____

NOTES:

FIRST RESPONDER
 NAME (Last, First): _____ LAST 4: _____

DD Form 1380, JUN 2014 (Back) TCCC CARD

Figure 1. DD Form 1380. Source: ESD (2014).

In 2011, The Defense Health Board listed high-priority issues in a report to the Assistant Secretary of Defense (Health Affairs) related to battlefield medical research (Dickey, 2012). A finding of the report:

At present, the documentation of in-theater trauma care is inconsistent, incomplete and often not transferred to either unit-based prehospital trauma registries or a trauma system registry, such as the Joint Theater Trauma Registry (JTTR). Improved methods to document pre-hospital care are essential. Further, command attention is vital to this aspect of combat trauma care and would help ensure our troops continue to receive the best possible battle field trauma care. (Dickey, 2012)

Eastridge et al. (2011) discussed an analysis of 3 years of trauma data, reviewing 4,382 records, from the Joint Theater Trauma Registry between August 2007 and March 2010. From those records it was found that 8% had complete vital signs, 5% had any documentation, and 87% had no prehospital documentation, as shown in Figure 2, from point of injury (Eastridge et al., 2011). This is an alarmingly high number of patients with no documentation and may have been detrimental to their follow-on care after evacuation.

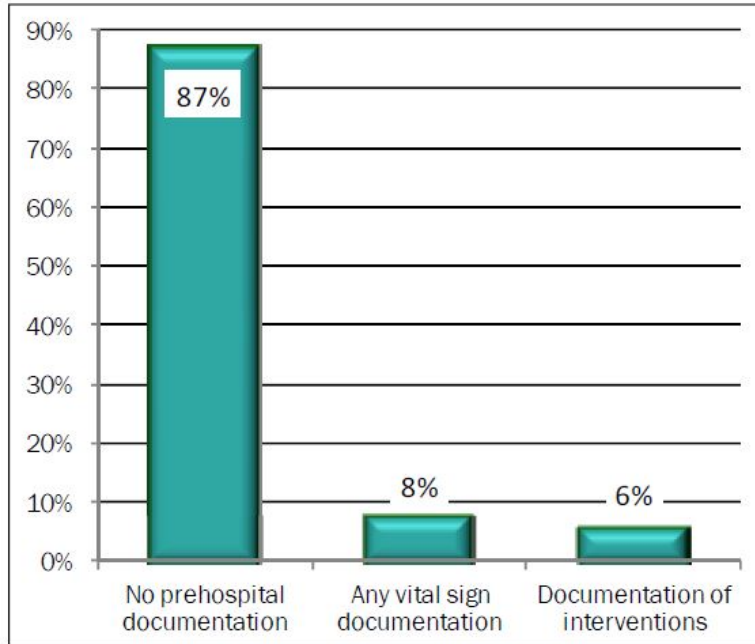

Figure 2. Prehospital Injury Documentation in Combat.
Source: Eastridge et al. (2011).

6. Networking Requirements

The research completed in this study was done as if it was a network-challenged environment and data transmission accomplished without using a cellular service network. The network must transmit patient data quickly and efficiently. The network should be portable and require little-to-no user configuration. Configuration should be accomplished prior to use because the corpsman, the user in this study, would most likely not have the knowledge to setup the network nor the time during a real-world operation. Solutions to networking requirements are addressed in Chapter III.

C. COMMON BIOSENSOR ARCHITECTURE

Fulfilling these requirements required selecting appropriate hardware, comprising the wireless physiological monitoring system, and software, the software platform communicating via wireless communications. These components work together in the wireless physiological monitoring system.

Regardless of design, any monitoring system will make use of a common architecture for biosensors, Figure 3. There are a number of possible architectures, and the sensors come in a variety of types and with either wired or wireless connectivity and may capture a multitude of important physiological readings. The system comprises three main components; on-body sensors integrated with a central collection point forming a body area network; the computer analyzing and displaying the sensor data; and network communications off-body. The display may be a laptop or desktop. Depending on the environment, the display could be local at a medical treatment facility or onboard a ship. There are numerous configurations for biosensor monitoring that produce basic and advanced vital signs. Choosing the right one will be critical to patients and to the hospital corpsman using a monitoring system that functions as designed in an operational setting.

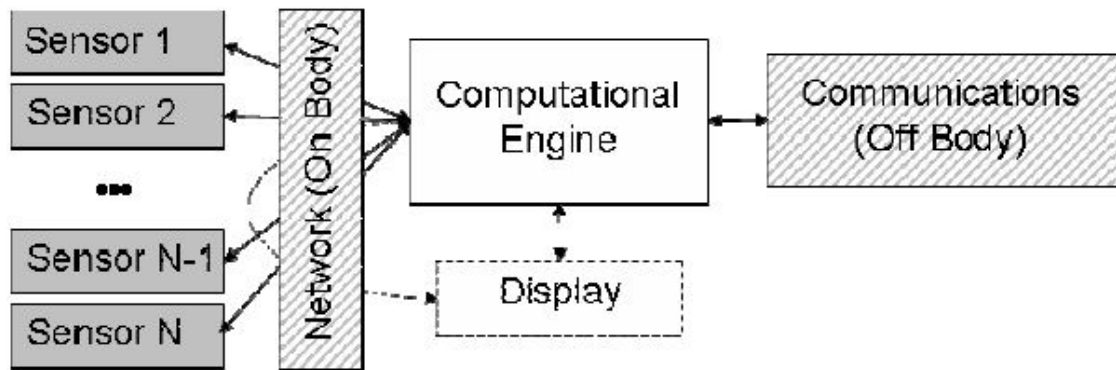

Figure 3. Common Architecture for Biosensor Monitoring.
Source: Buller (2010).

D. MONITORING SYSTEM

Remotely monitoring physiological data from patients in wartime is not a new concept, and has advanced in applications and considerations for military use (Research and Technology Organisation [RTO], 2010). Much prior work has been written on the topic of wireless physiological monitoring systems, some are reviewed in this chapter. This topic is relevant to my research because it explains the concept of how wireless monitoring has been used in the military and sets the foundation of using COTS biosensors in an austere environment.

As discussed in User Requirements, an available technology for remote physiological monitoring is the Hidalgo vital sign detection system (VSDS) experimented with USARIEM. The USARIEM used two different pieces of equipment to collect and transmit information: a) a sensor electronics module (SEM) and b) a health hub (Tharion et al., 2010). The SEM collected information and transmitted it to the health hub, and the health hub contained assessment software, data collection, and the network link for transmission to remote computers or other devices (Tharion et al. 2010). Midway through the study, the health hub capabilities were incorporated into the SEM, version EQ-03, which lessened the weight of the system and was one less piece of equipment for the participating soldiers to carry (Tharion et al., 2010). The VSDS used Bluetooth wireless technology (IEEE 802.15.1) to communicate between the sensor straps and monitoring system. Figure 4 shows the first two versions of the Equivital system.



Figure 4. EQ01 (top) and EQ02 (bottom).
Source: Friedl et al. (2016).

Physiological monitoring architecture systems have become more elaborate with advances in technology. COTS sensors are an alternative to traditional wired sensors found at clinics and hospitals. The makeup of an on-body network is becoming completely wireless and smaller than in the past. The computer processing, which gathers on-body network information, displays it, and then forwards the information off-body, has made tremendous leaps with the evolution of smartphones and tablets.

An important aspect of a good physiological monitoring system is the architecture, which enables interoperability between the COTS components and the network. One concept architecture that has been put forward is using COTS biosensors for chemical and biological defense, which can be applied and used in monitoring a patient's physiological signs during military training and operational settings. The concept was an example of combining different COTS tools to collect information to display on a networked device. This is similar to what this thesis explores. Figure 5 depicts COTS sensors using a concept much like Buller's common architecture, but with advances in network technology (Hirschberg et al., 2016).

Hirschberg et al. (2016) considered seven different types of COTS sensors for integration. Each sensor is connected by Bluetooth which was a connection type identified by Buller (2010) that provided reliable data transfer but was "expensive" in terms of power. The computational engine and display are separate in Figure 3 and integrated in Figure 5 in the form of a smartphone. The smartphone must be able to connect wirelessly to the COTS devices and have software installed on it to aggregate all of the data. Off-body communications is conceptually a network "cloud" to be relayed and displayed in a headquarters.

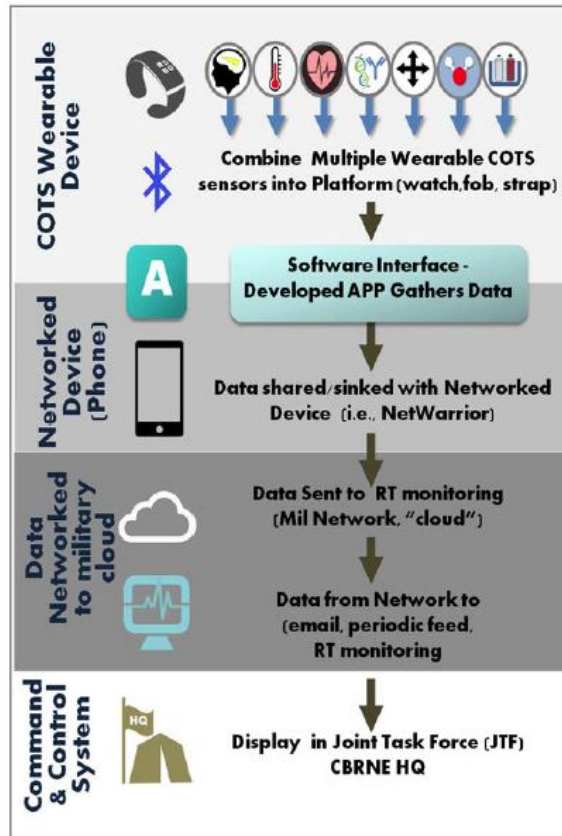

Figure 5. Concept of Sensor Integration.
Source: Hirschberg et al. (2016).

E. SOFTWARE PLATFORM SOLUTION

To function optimally, the hardware of the COTS system must be paired with software that is able to capture the information from multiple sensors. Montgomery and Anderson (2016) recommended research to develop a universal mobile smart device application to acquire biosignals from multiple disparate COTS sensors and transmit their information through a MANET. It is an integrated solution to patient monitoring, digital documentation, reference tools, telemedicine, point-of-care ultrasound, and global logistics management (Dorsch & Burnett, 2018).

Several features of BATDOK provide functions important to this research, including its ability to integrate wirelessly with many COTS biosensors and provide near-real-time information within a network. Figure 6 is the primary screen of BATDOK upon opening the

application, showing some of its features. Connecting to a MANET allows possible reachback support from a medical officer or situational awareness for those awaiting to receive casualties for treatment. The information that is viewed on one device can be seen on other devices connected to a MANET, and viewing networked patients can be manually disabled.

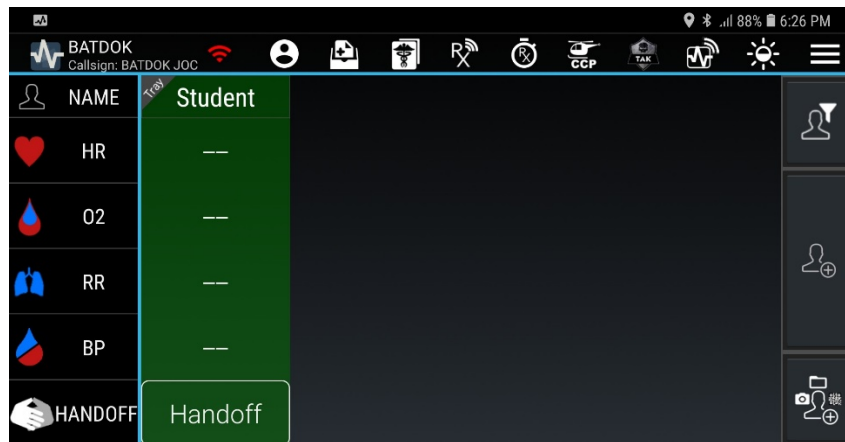

Figure 6. BATDOK's Primary Screen.

BATDOK allows for input, either manually or wirelessly, of rudimentary physiological measures such as heart rate, blood pressure, respiratory rate (Eastridge et al., 2011) and saving and exporting of patient documentation. Each patient's intervention information can be exported into two different Portable Document Format (PDF) forms, the DD Form 1380 and the Chronological Record of Medical Care form Standard Form (SF) 600. The SF 600 is a patient treatment form used throughout military medical treatment facilities to document patient care. Figure 7 is an example of the DD Form 1380 produced by BATDOK. This BATDOK capability offers benefits by saving time instead of manually writing information, adds legibility to the document, captures the information required in a field setting, and provides document mobility. In addition, the automatic population of SF 600 and DD Form 1380 may increase the casualty documentation in prehospital settings and reduce treatment error. A corpsman would be able to electronically document multiple patients simultaneously. If he was connected via a MANET to a medical officer, the corpsman may receive assistance with casualty care and patient monitoring from a subject matter expert. The tradeoff to this is an increase in power use and more data traffic along the MANET.

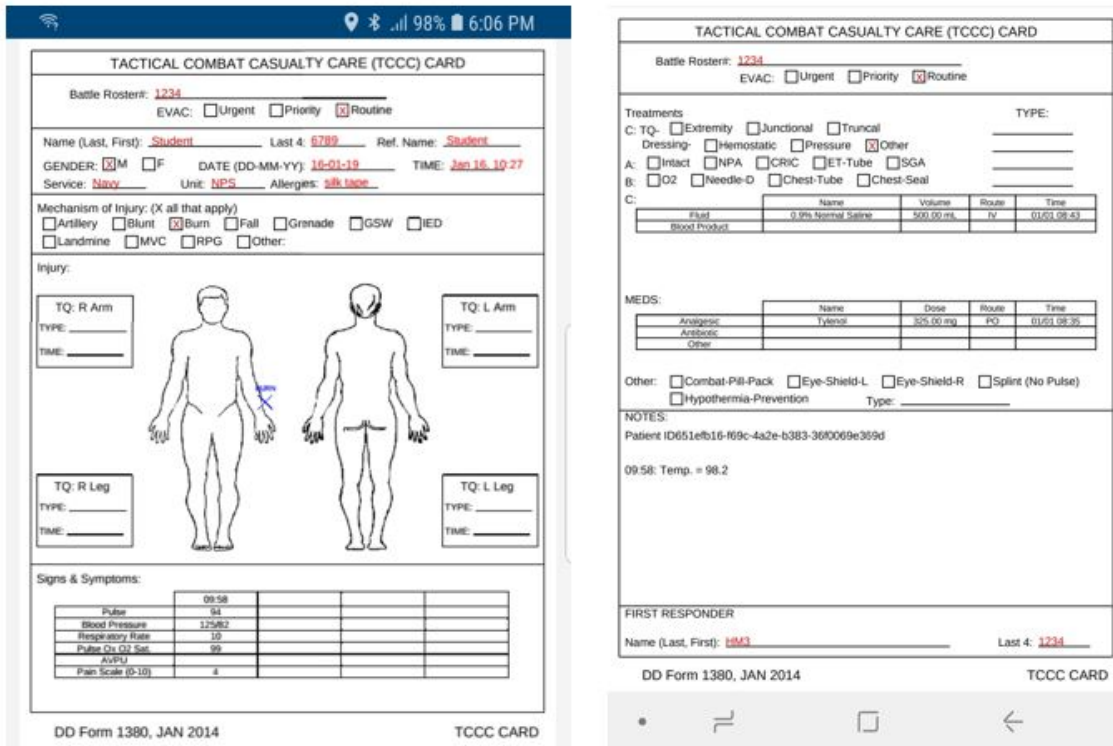

Figure 7. Screenshot of DD Form 1380 PDF from BATDOK

F. OSI MODEL CONSIDERATIONS

The equipment and software for the wireless monitoring and transfer of data use the layers on a network. It is important to know which layers of the OSI model the biosensors are using to communicate, to assist in identifying and diagnosing network problems. The Open Systems Interconnection (OSI) model is an international standardization of protocols used in the various network layers, developed by the International Organization for Standardization (Tanenbaum & Wetherall, 2011). The OSI model has seven layers: Physical Layer, Data Link Layer, Network Layer, Transport Layer, Session Layer, Presentation Layer, and Application Layer as shown in Figure 8. For the purposes of this thesis, only the layers that pertain to the experimentation are briefly described.

The Physical Layer pertains to how information is transmitted using 1s and 0s and whether or not the recipient receives it the same way (Tanenbaum & Wetherall, 2011). The Data Link Layer is where the Media Access Control (MAC) and Address Resolution Protocol

sublayers are located. MAC is a unique global address that is part of a network adapter or interface of a node (Saber com Logica, n.d.). The Network Layer physically is the level where routers operate. The routing information is located there. The routing of information can be based on static tables or it can be updated automatically to avoid failed components (Tanenbaum & Wetherall, 2011). Layer 3 is responsible for handling congestion and quality of service of the network. The Application Layer is where users initiate data transmission with the network. Once an application, such as Google Chrome is opened, a user is using the Application Layer. When an application quits unexpectedly it is most likely a problem at Layer 7. Interaction at this layer is usually where one initially finds out that there is a problem with one of the layers.

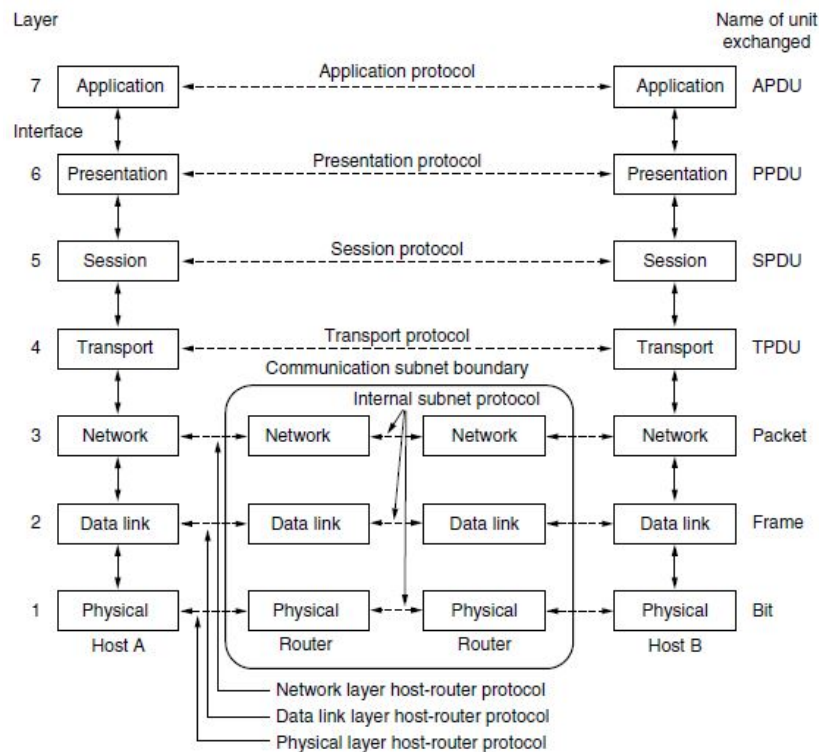

Figure 8. OSI Model. Source: Westcott and Coleman (2014).

G. WIRELESS COMMUNICATIONS

There is much literature comparing Bluetooth, UWB, and ZigBee. Bluetooth is used almost everywhere (office accessories, sports equipment and sensors, and health care

and it may be used more often because it was the first wireless close-proximity technology with large corporate support when Intel, Ericsson, and Nokia collaborated to its standardization in 1996 (Bluetooth, n.d.). Bluetooth specifications are maintained and updated by the Bluetooth Special Interest Group. Zigbee was publicly released in 2004 (Electronicsnotes, n.d.). Its operation has a long battery life because of its low power consumption and its range is the same as Bluetooth at 10 meters. UWB's evolution began in the 1960s and was first patented in 1973 (Lakkundi, 2006, p. 18). UWB differs from Bluetooth and Zigbee in that it offers a higher data throughput up to 110 Mb/s. UWB is best because of its wide bandwidth.

The sensors that would be used in a field environment would ideally be wireless and heavily rely on short-range technologies such as Bluetooth, UWB, and Zigbee. The biosensors used during this experimentation employ Bluetooth technology. The standards for the three technologies are explained within the Institute of Electrical and Electronics Engineers (IEEE) 802 standards. IEEE 802 covers many different network standards within the local and metropolitan area networks (LAN/MAN) such as Wi-Fi (802.11) and Wireless Personal Area Network (WPAN) (802.15) or short-range wireless. Within short-range wireless are Bluetooth (802.15.1), UWB (802.15.3), Zigbee (802.15.4), and Wi-Fi (Pothuganti & Chitneni, 2014, p. 655).

1. Wireless Personal Area Network

WPAN is the network around one's immediate area. For example, everything wirelessly connected, or able to be connected, is within one's WPAN. There are many types of WPAN sensors used for physiological monitoring. WPAN sensors are able to connect wirelessly in different ways; such as found in Bluetooth, UWB, or Zigbee connections. For the purpose of this thesis, only Bluetooth was used because the biosensors available employ Bluetooth. An injured Marine would presumably be within the 100-meter maximum distance of Bluetooth's range during treatment by a corpsman.

2. Mobile Adhoc Network (MANET)

Besides close-communication standards, a wireless monitoring system in an austere environment must have a way to transmit data at a longer distance than what a WPAN can

provide. A MANET is an effective solution to transmit monitoring system data. MANETs were first developed by the Defense Advanced Research Project Agency (DARPA) when the Department of Defense requested a quick deployable communication system (Wang, Xie, & Agrawal, 2009). MANETs have five key characteristics: self-forming, self-configuring, self-healing, dynamic topology, and constrained resources (Wang et al. 2009). Figure 9 shows an example of a MANET for communicating between nodes during a Naval Postgraduate School Center for Network Innovation and Experimentation (CENETIX) experiment at San Clemente Island, California in 2018 to employ a network control system of unmanned and manned nodes to support an operational mission (A. Bordetsky, personal communication, February 13, 2019). The experiment used Wave Relay nodes attached to submersibles, unmanned aerial vehicles (UAV), ground units, and ships. All of the nodes established their own mesh network and are an example of what can be implemented in an austere environment.

If a UAV goes out of range of the network, the network must be able to change its routing dynamically and operate without the out-of-range node (Figure 9). If three additional nodes from one of the Blue Team Units that were not part of the original network turn their own radios on, the MANET automatically configures itself to include the three additional nodes; this is a dynamic topology. All of this could be beneficial if a member of the Blue Team Unit was injured and had to be evacuated with an escort. The MANET would automatically reconfigure itself when the casualty and escort exceed the MANET range. When the escort returned, he would join the MANET again without any manual configuration.

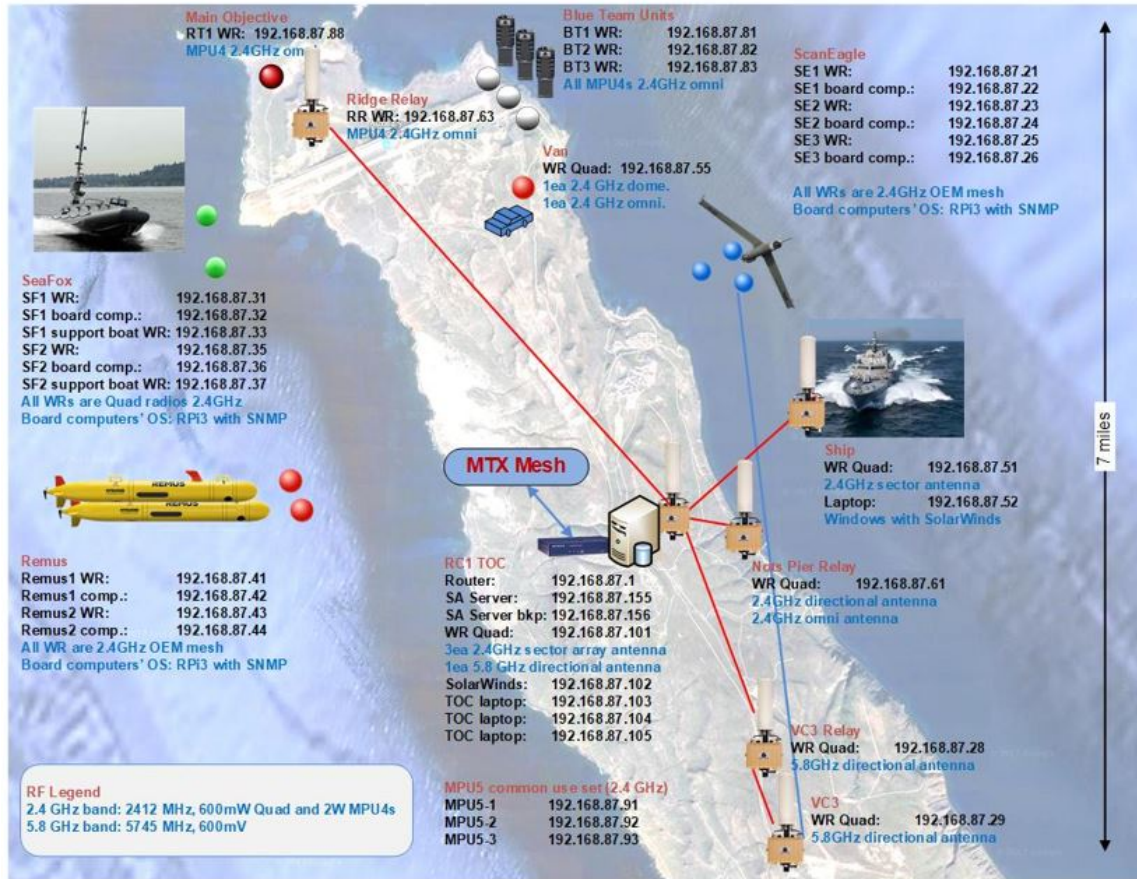

Figure 9. MANET Backbone for a MTX Networking Experiment.
Source: Bordetsky (2018).

Resources are constrained in MANETs, such as limited power. The radios are reliant on battery operation. Unmanned nodes are limited by their own power source. The manned nodes will have the battery currently installed and possibly a few extras at the expense of weight and mobility. Weight and mobility is not a concern for the nodes that are seagoing. In addition, use, distance between radios, data being transmitted, and weather can all affect battery life.

3. Bluetooth Networking

The biosensors used during this research employed Bluetooth technology to connect to the Android Samsung S9+ smartphone. Bluetooth (IEEE 802.15.1) is a wireless communication standard originally conceived in 1994 by Ericsson Mobile

Communications when the company began to look at a low-power-consumption system to replace the cables in the short-range area of mobile phones and accessories (Ferro & Potorti, 2005). Today, Bluetooth is commonplace in a variety of uses: smartphones, offices, household electronics, and hospitals. Bluetooth has two primary topologies: piconet and scatternet. Piconets have a maximum of eight nodes with one as a master node, and of which, seven can be active slaves. A master node may have more than seven slaves associated with it, but only seven may be active at any given time. The nodes associated but not active are considered “parked.” Figure 10 is a representation of a master to slave connection from its simplest one-to-one topology to a Piconet with active and parked nodes. Piconets may be connected to one another and form a Scatternet by a master acting as a slave in another Piconet (Ferro & Potorti, 2005).

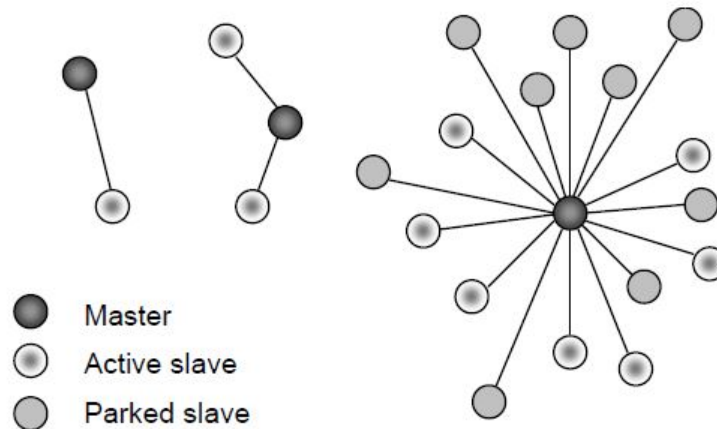

Figure 10. Bluetooth Piconet Example.
Source: Ferro and Potorti (2005)

Bluetooth uses a radio signal multiplexing technique called frequency hopping spread spectrum (FHSS). Ferro and Potorti (2005) described FHSS as follows:

Frequency hopping consists in accessing the different radio channels according to an extremely long pseudo-random sequence that is generated from the address and clock of the master station in the Piconet. Using this method, different Piconets use different hop sequences. When entering a Piconet, a slave waits for an Inquiry message from the master to learn the

master's address and clock phase, which it then uses to compute the hopping sequence. The transmission channel changes 1600 times per second. (p. 4)

The maximum range of Bluetooth is 10 meters or 100+ meters dependent on a special radio kit (Baker, 2005). The range is acceptable for operating in a close proximity area as in wireless headphones connected to smartphone or smartwatch, hospital and clinic settings, and would lend itself well to a corpsman treating nearby casualties in a tactical situation. Bluetooth has a transmission rate of 1 Mbps which is ideal for biosensors because they do not require large transmission rates. Its low power requirement is effective for a field environment where it is difficult to find constant power, extra batteries are not readily available, and recharging is not an option. Bluetooth characteristics are found in Table 3. There are many COTS Bluetooth sensor and accessories available on the market. A reason for this is because Bluetooth operates on the 2.4 GHz RF band. The range of the 2.4 GHz band is 2.4 through 2.4835 GHz. This range may be used by anyone to use radio equipment to transmit without obtaining a license.

Table 3. Bluetooth Characteristics.
Adapted from Baker (2005).

Characteristic	Bluetooth
Range	
As designed	10 meters
Special kit or outdoors	100+ meters dep. on radio
Data rate	1 Mbps
Network Latency (typical)	
New slave enumeration	20s
Sleeping slave changing to active	3s
Active slave channel access	2ms
Power profile	Days
Security	64 bit, 128 bit
Operating Frequency	2.4 GHz ISM
Complexity	Complex
Network Topology	Adhoc piconets
Number of devices per network	8
Scalability/Extendibility	Low/No
Flexibility	Medium, profile dependent
Resilience and reliability	Medium

Bluetooth has its own layer stack that is similar to the OSI model's Layer 1-Physical and Layer 2-Data Link of the OSI model, as depicted in Figure 11. The following list

describes the characteristics of the layers and protocols found in a Bluetooth stack (Tanenbaum & Wetherall, 2011).

- The physical radio layer is for radio transmission and modulation.
- The baseband layer is comparable to the OSI MAC.
- Link manager establishes the channels between devices, power management and quality of service, pairing, and security.
- The Logical Link Control Adaptation Protocol is responsible for frames and reliability.
- The radio frequency communication emulates the serial port found on PCs for connections.
- Applications are in the upper layers. A specific profile in the application only contains the necessary protocols needed to operate.

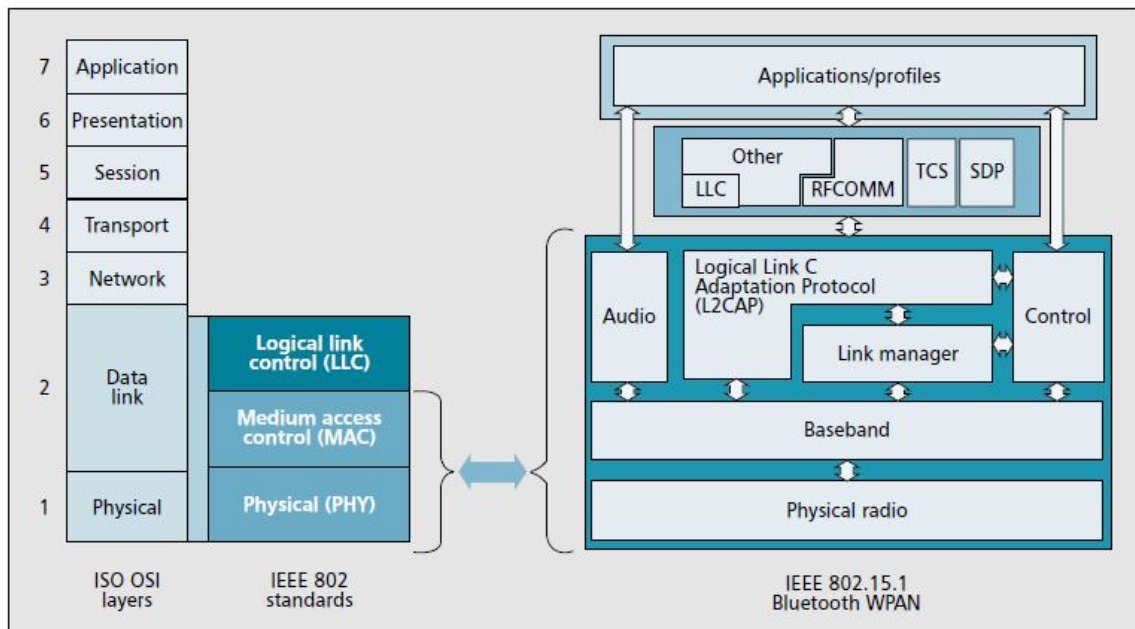

Figure 11. Bluetooth Stack within the OSI Model. Source: Ferro (2015).

This chapter explored the requirements for using a vital sign monitoring system and the necessary components for successful transmission of patient data within an austere environment using a MANET to communicate. Reviewed were system requirements that emerged from the operational context explained in Chapter I; a software platform to monitor, collect, and transmit patient data and wireless communications to relay the data in an austere environment. The next chapter explores the networking capabilities of using a software platform in a MANET and identifies biosensor networking requirements through a series of experiments starting from a selection of equipment, biosensors, and software proceeding to experiment configuration and concluding with a sequence of field experiments selected to best mimic a network environment a corpsman may find himself in during an operation while deployed with the Marines.

THIS PAGE INTENTIONALLY LEFT BLANK

III. EXPERIMENT METHODOLOGY

This chapter explains the methodology and iterative Phases of experimentation with BATDOK and connected sensors in a MANET. To replicate an austere environment, all communications were conducted using a MANET only, with no other means such as a LAN or cellular data networks (3G/4G/LTE).

Phase 0 selected the equipment, software, and configuration to use during the experimentation. Objectives included familiarization and configuration for the planned experiments. The equipment that was selected included the physiological biosensors, the smart devices, and the nodes that form the MANET. The software chosen were for the biosensors to connect to the smart devices and the software necessary to analyze the network performance.

Phase I consisted of lab testing the software and COTS sensors and point-to-point communication between MPU4s. The objective was to assess which factors affect the software platform's ability to relay data across a wireless network. Two nodes were used in this Phase to ensure the network operated as configured before increasing the number of nodes to three. Baseline tests were taken with the analysis software to examine the functionality of the MPU4s and to determine readiness to move to the next Phase.

Next, Phases II and III involved line-of-sight (LOS) and beyond-line-of-sight (BLOS) field experiments in which I integrated results from Phase II, and added an additional node into the network to establish a mesh network. The objective was to see how a node, or nodes, added to the MANET would affect patient data transmission between the software platforms. A minimum of one additional MPU4 was needed to transmit data between the smartphone monitoring the patient and the smartphone representing the higher echelon of care.

Finally, Phases IV and V progressed to a field environment over a greater, operationally relevant distance, increasing the range between the two end nodes. The objective was to place biosensor data on the network across a MANET, and to evaluate the characteristics of the MANET in which it was necessary to relay data multiple times. The last Phase was to determine if BATDOK is a feasible solution to improve monitoring and

mortality rates in austere environments. The number of patients with demonstration sensors and COTS biosensors remained the same. Figure 12 is a breakdown of each Phase of experimentation.

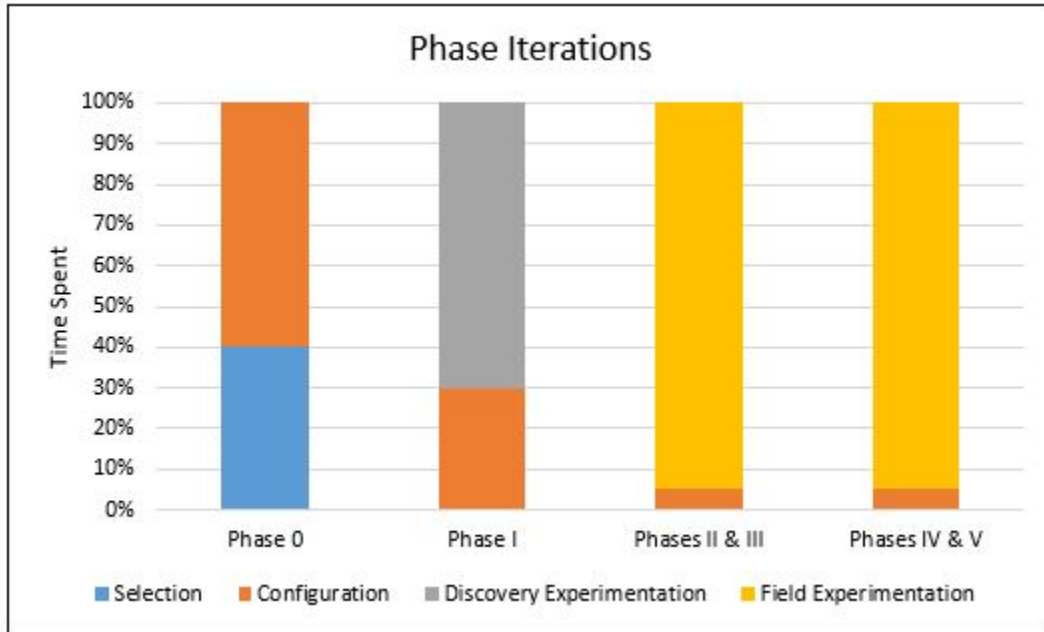

Figure 12. Experiment Plan

A. PHASE 0: SELECTION OF EQUIPMENT, BIOSENSORS, AND SOFTWARE

Phase 0 consisted of identifying and selecting the equipment, software, and system configuration used during the experimentation. Some of the equipment was procured from the Naval Postgraduate School CENETIX specifically for this thesis, and some were resources already available for student research. The network management software SolarWinds (discussed in Chapter II), captured all network information necessary for analysis.

1. Equipment

The equipment was selected to best mimic usage in an austere environment. The equipment needed to be able to operate on its own or within a MANET. Thus, it had to be

portable and have sufficient power to last for the duration of the experiment Phases. The equipment consisted of MANET nodes, smart devices, SNMP agents, and biosensors.

a. MANET Nodes

Although a cellular network (LTE) was available, this research used a MANET to transmit sensor information. Commercially available network solutions were not used. In an austere environment, friendly forces would not use civilian communication to send and receive data that could be intercepted and exploited. All communication between nodes was accomplished on the Persistent Systems Man Portable Unit (MPU) using its Wave Relay MANET. Wave Relay is a proprietary routing algorithm that allows users to add a large number of meshed devices to form the infrastructure (Persistent Systems, n.d.). Two MPU models were used, the MPU Generation 4 (MPU4) and Generation 5 (MPU5). The MPU4, Figure 13, allows connections via Wi-Fi and an associated service set identifier (SSID). The Wi-Fi of the MPU4 and its SSID made it easier to connect with the different devices at any given time.

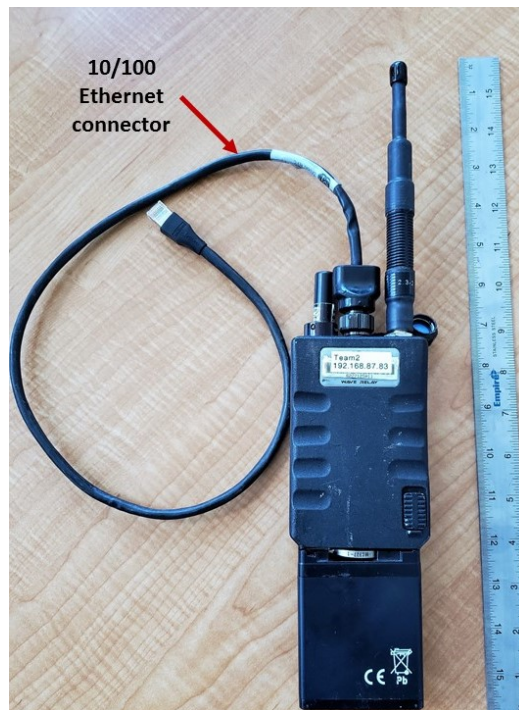

Figure 13. MPU4 with Optional 10/100 Ethernet Connection

The MPU4 operates in the frequency range of 2312–2504 MHz and has an output power of 33dBm/2W—the output power is only available to the military (Persistent Systems, 2016). Table 4 shows additional specifications for the MPU4. A fully charged battery will last approximately 14 hours, which is important when a small military force has to remain in communication with one another and without access to electricity. The optional 19-pin to 10/100 Ethernet connector was used to connect to the laptop running the SolarWinds analysis and Wave Relay Management Interface software; otherwise all other connections to the MPU4 were via its Wi-Fi connection capability. There is an optional, but not used, 19-pin to Micro USB adapter cable which connects to an Android smart phone for network connectivity and power to the MPU4 and the MPU5. This is important because the MPU5 does not have Wi-Fi access for an Android phone to connect.

The MPU5 has a few key differences in specifications, as shown in Table 4. The primary difference is that the MPU5 has a three RF antennas, seen in Figure 14, as a standard configuration; each has 2W of output power (Persistent Systems, 2017) and a 2.2–2.5 GHz operating frequency. More antennas equate to better area coverage and better throughput. Similar to the MPU4, the high output version of the MPU5 is for military use only.



Figure 14. MPU5 with an Ethernet Connector and 3 RF Antennas

Table 4. MPU4 and MPU5 Radio Specifications. Adapted from Persistent Systems (2016) and Persistent Systems (2017).

Specifications	MPU4	MPU5
Modulations	OFDM, DSSS, CCK	OFDM
Throughput	27 Mbps	100+ Mbps
Size (with battery)	7.8 x 3.0 x 1.5 in (with battery)	4.6 x 2.6 x 1.5 in (without battery)
Weight (with battery)	1.9 lbs (with battery)	0.81 lbs (without battery)
Security	FIPS 140-2 Level 2	CTR-AES-256 Encryption
Frequency Range	2312–2507 MHz	2200–2500 MHz
Output Power	33dBm/2W	6W (2W each antenna)
Enclosure	IP67 Rated	IP68 Rated

b. Smart Devices

To provide medical or operational support, hospital corpsmen will require some sort of end-user device with which they can collect and save information or that can pass the information to someone or somewhere else. The devices selected operate on the Android OS because it allows greater control of installation and customizable features than other OSs such as Apple’s iOS. The Android OS devices, shown in Figure 15, that were selected to install and run BATDOK were the Samsung Galaxy S5, Samsung Galaxy S9+ and Sincoole Technology ST85. All three have Bluetooth and Wi-Fi to connect to the biosensors and the MPU4 respectively. The Samsung smart phones did not have cellular service activated. They connected to the MPU4s by Wi-Fi through each radio’s SSID to model a possible connection type in a MANET.



Figure 15. Galaxy S5 (left), Galaxy S9+ (middle), and ST85 (right).

c. Simple Network Management Protocol Agent

Two of the research questions pertain to data flow and throughput of data in a MANET: specifically, what factors affect data flow in a MANET with a software platform and biosensors and how does an influx of patient data affect MANET throughput? To help answer these questions, Simple Network Management Protocol (SNMP) agents were used. SNMP is used to monitor the network and “is the most widely used NMS [network monitoring system]” (Subramanian, 2010). The SNMP structure used was a single-tier structure; with a SNMP agent talking to another SNMP agent and each of them running on two Raspberry Pi computers. If a remote server was used, then it would be considered a two-tier application model. The SNMP manager was on a laptop and the agents it monitored were connected to the MPU4s. Each SNMP agent used a Raspberry Pi which is a credit-card sized computer that runs Linux (Raspberry Pi, n.d.). The Raspberry Pi was connected to an external battery pack to provide power (Figure 16) and connected via the MPU4’s 10/100 Ethernet connection. This setup allowed the SNMP manager to monitor the data transmitted and received by all of the MPU4s while they were connected to the same MANET.

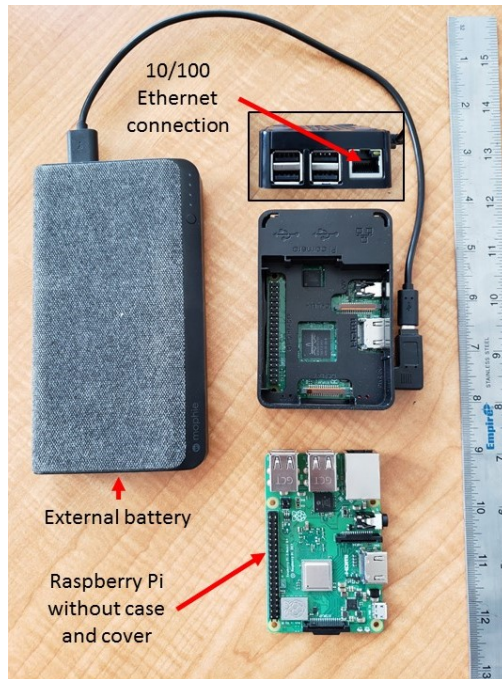

Figure 16. Raspberry Pi with External Battery

d. Observations

The Samsung Galaxy S5 smartphone and ST85 tablet were initially the two EUDs selected to run the BATDOK application during the configuration and experiments. It was found early during the configuration that they were not adequate to provide the necessary functionality to complete thorough experimentation. The S5 had versions 2.6.5.7 and 3.0.4 installed initially. The S5 repeatedly “froze” during use with both software versions. Two different S5 smartphones were used and both could not run BATDOK sufficiently. The ST85 did not freeze but it had difficulty receiving and transmitting patient biosensor information. A few weeks after the S5 and ST85 were being experimented with, the NPS CENETIX department procured Samsung Galaxy S9+ smartphones. Two S9+ smartphones were installed with BATDOK version 3.0.4, and later version 3.1, and it performed as expected with both versions. The freezing of the application stopped and patient data was shared and received. The S9+ was the only EUD used for the remainder of the configuration and experimentation.

A current EUD was essential to load, run, and test the software platform. The issues of the Samsung S5 may have been because it was an older model and had different

specifications than the Samsung S9+. The Samsung S5 was released in 2014 (GSMARENA, n.d.a) and the S9+ was released in 2018 (GSMARENA, n.d.b). It is not exactly known why S9+ performed better. Testing compatible biosensors that were not used in the experimentation would be beneficial to know how they affect data transmission in a MANET and between the EUDs.

2. Biosensors

In addition to communication equipment, creating patient data also required biosensors; therefore, the next step in Phase 0 was to select suitable biosensors. Virtual biosensors were used along with physical biosensors to add more patients, and their vital sign information, to the network. Although there are more than two biosensors that connect to BATDOK, only two were selected due to their ease of procurement and compatibility: the Polar H10 heart rate sensor and the Masimo MightySat fingertip pulse oximeter. Virtual sensors and Bluetooth-enabled physiological biosensors were both used for each experiment Phase: BATDOK demonstration sensors, Masimo MightySat pulse oximeter, and Polar H10 heartrate monitor. In an austere environment, power and portability are important to the treating hospital corpsman; the biosensors selected are small, portable, and self-powered, each with an internal battery.

a. BATDOK Virtual Sensors

One type of sensor employed in this research is the BATDOK demonstration sensor, which is useful for training users on the many features of BATDOK without having to use vital sign equipment. BATDOK's software is configured with the ability to create and assign "demonstration" vital signs to patients. BATDOK is able to assign "demonstration" sensors to patients as if the patients were attached to real biosensors, which is useful if actor-patients or vital sign equipment is unavailable. There are four demonstration sensors available and each produces a random set of vital signs for monitoring. They are assigned to a patient in the same manner as a normal sensor, by selecting an available sensor from a list. Once the sensor is connected, a green light confirms connection. Figure 17 is the visual representation of assigning a demonstration sensor to a patient.

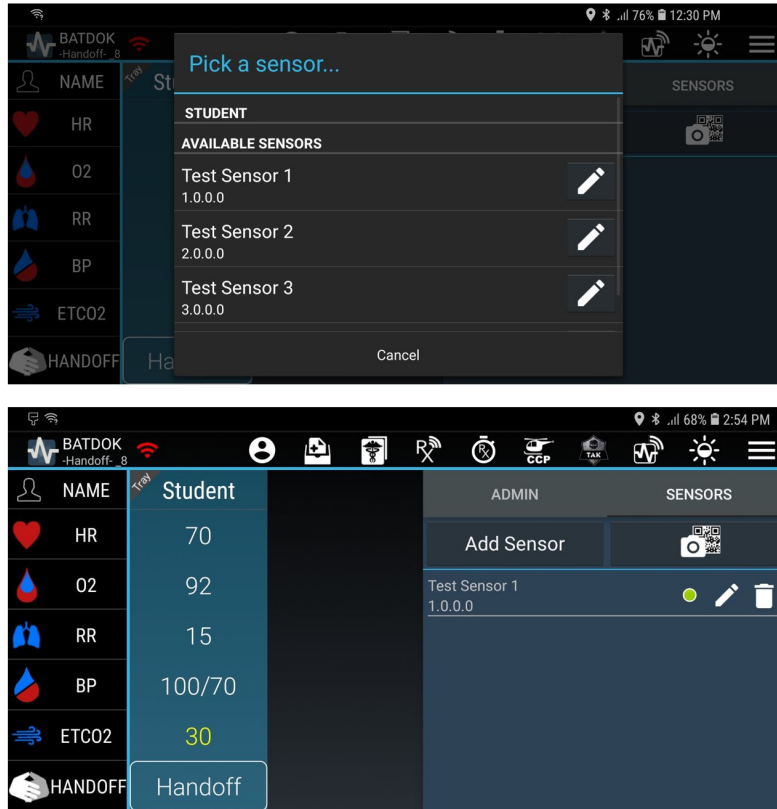

Figure 17. BATDOK Demonstration Sensor Selection (top) and Showing Vitals (bottom)

b. Masimo MightySat

The MightySat, Figure 18, is a portable sensor that measures and reads five parameters of health data: oxygen saturation, pulse rate, perfusion index, respiration rate, and pleth variability index (Masimo, 2017). The two parameters used in this research were respiration and pulse rate, although the remaining three were displayed on the MightySat unit. Respiration rate is the amount of full breaths taken (inhaling and exhaling is one breath) in a minute and pulse rate is the amount of heartbeats per minute.

The MightySat also transmits data via Bluetooth Low Energy and operates on the 2402–2480 GHz frequency. The recommended range is 3 meters (10 ft.) line-of-sight (Masimo, 2017). Since it is not a continuously worn monitoring system its user acceptability should be high when located at the point of injury.



Figure 18. Masimo MightySat

c. Polar H10 heartrate monitor

Although the Polar H10 reads a heartrate just as the MightySat does, the H10 was used to test the ability of the software platform’s ability to capture biosensor information from different manufacturers. The Polar H10 monitor, Figures 19 and 20, is worn against the skin and transmits heart rate data with the use of an attached chest strap. It is made up of two pieces of equipment: a strap worn around the chest and a sensor which attaches to the strap. The sensor may be removed to allow for cleaning of the strap and replacement of the sensor or its battery. Heart rate is measured by counting the number of heartbeats in one minute. The Polar H10 is marketed as a fitness and sport product but is compatible with not only fitness-specific products but also third-party applications (Polar, n.d.a).

The Polar H10 transmits data via Bluetooth Low Energy and operates on the 2402–2480 GHz frequency (Polar, n.d.d). The Bluetooth transmission range of the Polar H10 is 5 meters, (16.4 ft.) at the minimum and ranges vary between 10 to 35 meters (32.8 to 114.8 ft.); it may be possible to reach 100 meters (328.1 ft) in an optimal open-field environment (Polar, n.d.c). With its extended battery life of 400 hours, approximately 16 days of continuous use,

it could provide enough power to last during an operation in an austere environment. With its small size and soft strap, it may be acceptable for wear over a prolonged period of time such as a mission in an austere environment and is water resistant, adding to its operational usefulness.



Figure 19. Polar H10 Heart Rate Sensor. Adapted from Polar (n.d.b).



Figure 20. Polar H10

d. Observations

The demonstration biosensors option in BATDOK was a valuable option to have available; they provided sufficient patient vital sign information during the configuration. They made it easier to perform experimentation because it was not necessary to find four people in order to monitor their vital signs. The demonstration sensors also provided a cost-savings while not having to purchase additional COTS biosensors. The Masimo MightySat pulse oximeter and the Polar H10 heart rate monitor were reliable and easy-to-use biosensors.

3. Software

The next step in Phase 0 was to select the software for the end user and the MANET, and for data collection. Because the experimentation required a specific configuration, software had to be used and configured on all of the aforementioned equipment EUDs and equipment. The ability of customizable configuration allowed each phase of the experimentation to be adapted and modified as necessary.

a. BATDOK Software

BATDOK, as a software platform, allows multiple COTS biosensors from different manufacturers to be captured, saved, and relayed as necessary. Three different versions of BATDOK were available for this research, versions 2.6.5.7, 3.0.4, and 3.1; and they were provided by the Air Force Research Laboratory.

b. SolarWinds Engineer's Toolset

To collect network data and analyze performance I used the network management software SolarWinds Engineer's Toolset installed on a laptop, a Panasonic Toughbook 74. The Toolset offers a variety of tools for network management, though not all were used during the experiments. The management tools primarily used were from the Discovery, Performance Management, and Management Interface Base (MIB) Browser subsets. From the Discovery subset, Ping Sweep was used to check the connectivity to the nodes. The SNMP Sweep was used to identify whether or not the Raspberry Pi computers were connected to the network. Each Raspberry Pi had an SNMP agent running.

The two tools used from the Performance Management subset were the SNMP Graph, Figure 21, and the Bandwidth Gauge, Figure 22. The SNMP Graph provided the capability of capturing information in near real-time with an option to personalize the polling interval. The SNMP graph provided a visual representation of what was happening at each node and a way to export raw data to Microsoft Excel to support further analysis. The SNMP graph provided information as long as the Raspberry Pi remained connected to the MPU4. The Bandwidth Gauge monitored and captured the amount of data received or transmitted by a remote device using SNMP and displays in two separate gauges: one for transmitted and one for received (SolarWinds, 2019).

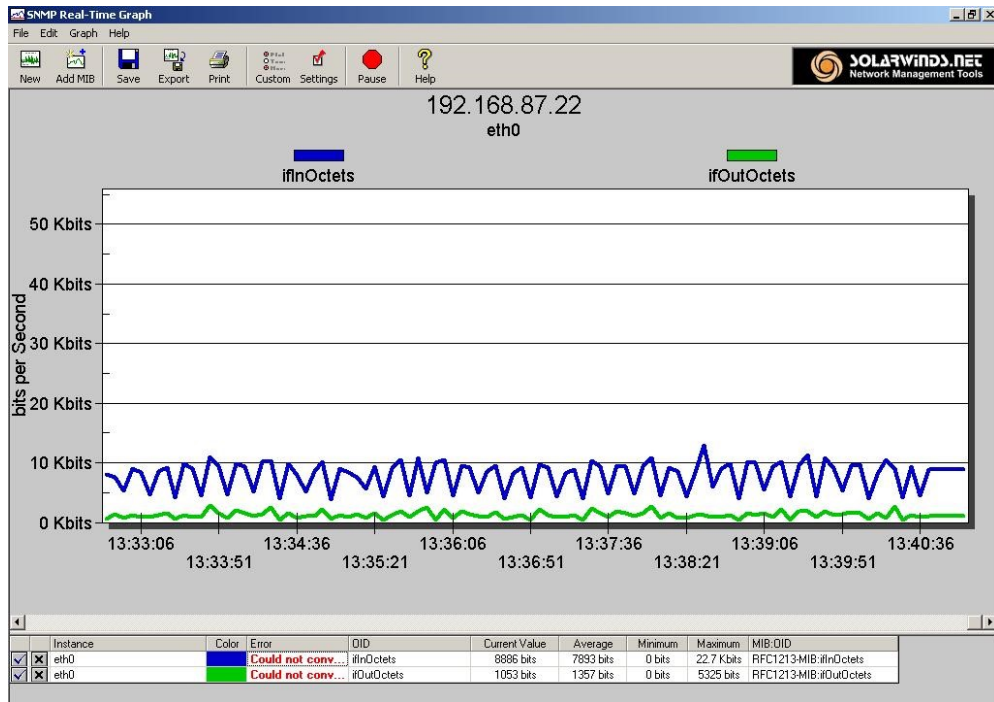

Figure 21. SolarWinds SNMP Real-Time Graph

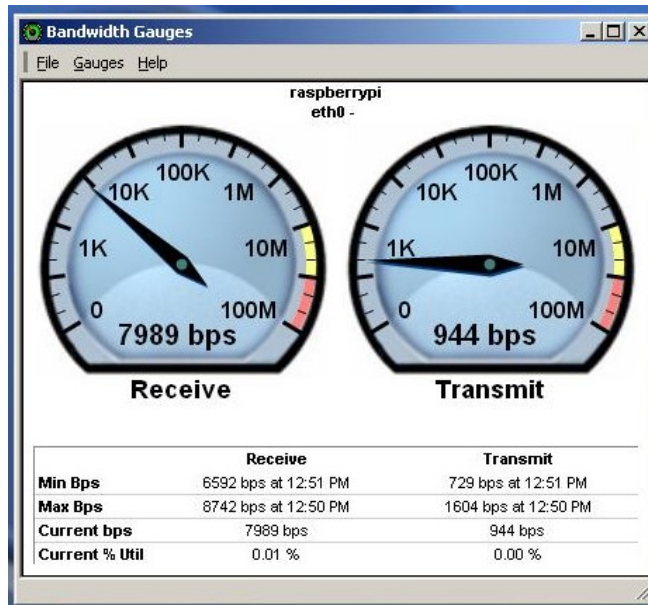

Figure 22. SolarWinds Bandwidth Gauge

The last category of management tools, MIB is an information model that a SNMP manager, or agent, uses to store and exchange specific management information about the network and its components (Subramanian, 2010). The SolarWinds MIB Walk allows a user to determine what MIBs are supported by a particular SNMP. If one wants to know how many packets have been dropped, the SNMP agent must be able to collect that information. Not all MIBs are available from an agent. By knowing which MIBs are available it can be determined how data is being transmitted from and to a node.

c. Persistent Systems Wave Relay Management Interface

The nodes in a MANET are self-healing and self-forming, but configuration must be completed in order for the nodes to perform properly. All of the nodes required no configuration due to the MPUs having been set up for prior MANET experiments. Therefore, time for experimentation was maximized. The MPU4s were configured in the Persistent Systems Wave Relay Management Interface (MI), Figure 23. The MI is also a way to view and collect network and node information. Detailed status and information for a specific MPU4 can be viewed and configured with the MI password and MPU4 IP address in a web browser.

Furthermore, two MI tools, MANET Monitor and Neighbor Status, were used to monitor the mesh connectivity, remaining battery life of each node, signal-to-noise ratio (SNR), and the number of neighbors connected.

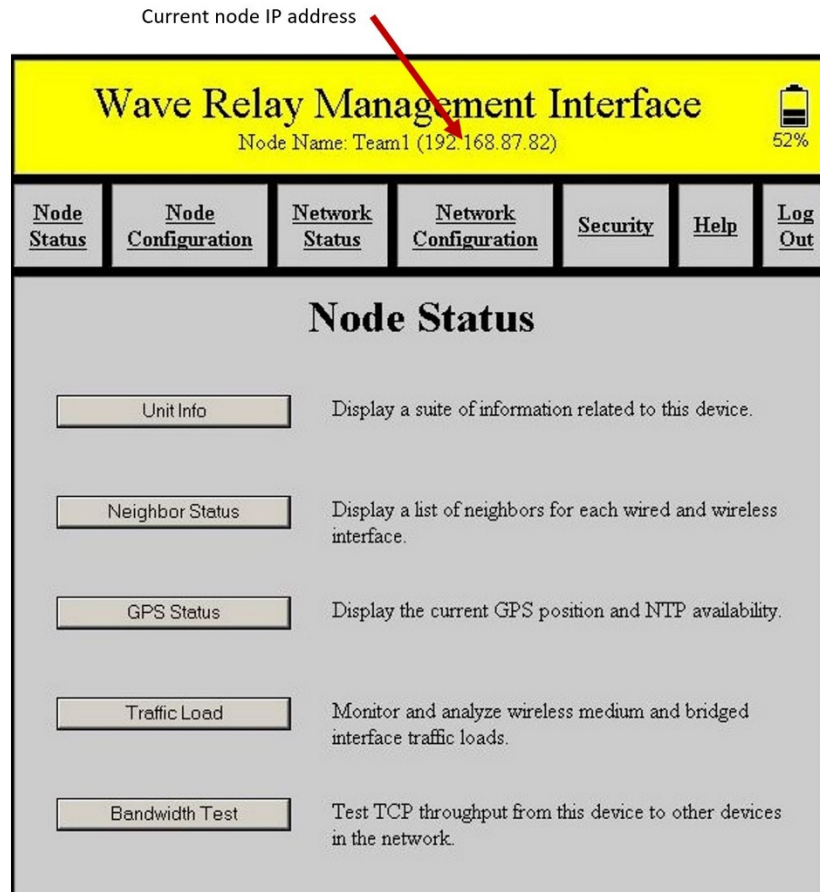

Figure 23. Persistent Systems Wave Relay Management Interface

d. Node Pinger

Node Pinger allows entry of up to five IP addresses, Figure 24. An IP address is manually entered and remembered as a preset if desired. Each address is pinged from the computer, or laptop, the Node Pinger is running on. Pings are sent every second continuously or until the IP address is deleted or the program is closed. Three colors represent the connection status; green means there is a connection (ping sent and reply received within 600 ms), yellow means there was a delay of more than 600 ms but the ping

was successful, red means there is no connection (ping sent and no reply received). The display, which moves from right to left, shows a history of the previous ping attempts. Node Pinger is similar to the SolarWinds Ping Sweep application.

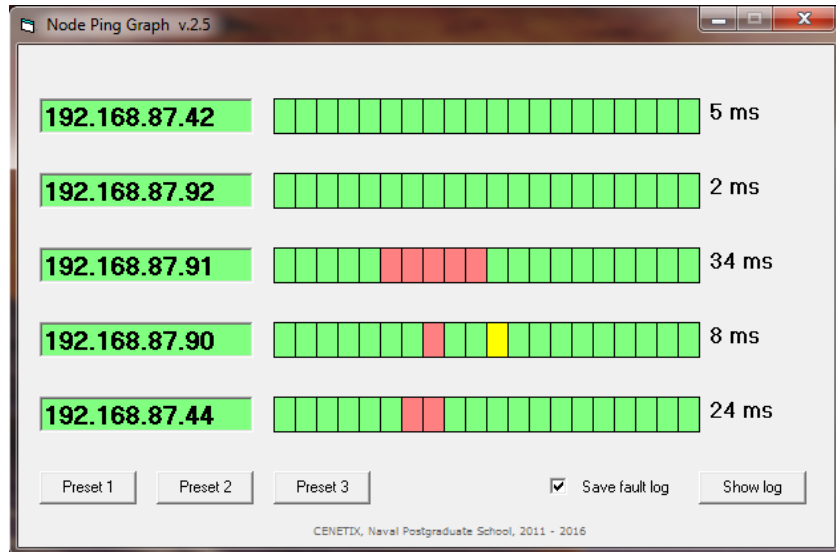

Figure 24. Node Pinger Program

e. Observations

BATDOK version 2.6.5.7 was initially installed and used on the Galaxy S5 and the ST85. The S5 did connect to the biosensors and was able to run the demonstration sensors. For some reason, the S5 did not perform well when viewing networked patients between separate devices such as the S5 and ST85. Networked patients would not always show up and the application often crashed. There may have been interoperability issues between the older S5 phone and version 2.6.5.7. The S5 did not have version 3.0.4 installed because the S9+ was acquired prior to receiving version 3.0.4. The ST85 had similar issues as the S5 and also required a password every time BATDOK was running in the background or switched applications. After installing version 3.0.4 on the S9+, the patient networking problems resolved itself and all of the features of BATDOK were available and worked as expected.

B. PHASE I: EXPERIMENT CONFIGURATION

Having identified and selected the necessary equipment and software in Phase 0, the objective in Phase I was to configure the equipment and software and test the system.

1. Actions

The first step was to assemble a Network Operating Center (NOC)—where the information from the hospital corpsman treating the patient in the experimental scenarios is received, interpreted, and acted upon if necessary. A laptop and an Android smartphone were connected to an MPU4 via Wi-Fi and a Raspberry Pi (SNMP agent) was connected to the MPU4 via Ethernet cable which formed a bundle. This bundle, with the laptop, formed the NOC, marked by the red circle in Figure 25. The other Android smartphone is kept by the hospital corpsman in the field. The corpsman's smartphone was connected to a MPU4 via Wi-Fi and another SNMP agent was connected to the MPU4 via Ethernet cable; another bundle marked by a blue circle in Figure 25. Both SNMP agents were powered by an external battery. The described setups are shown in Figure 25.

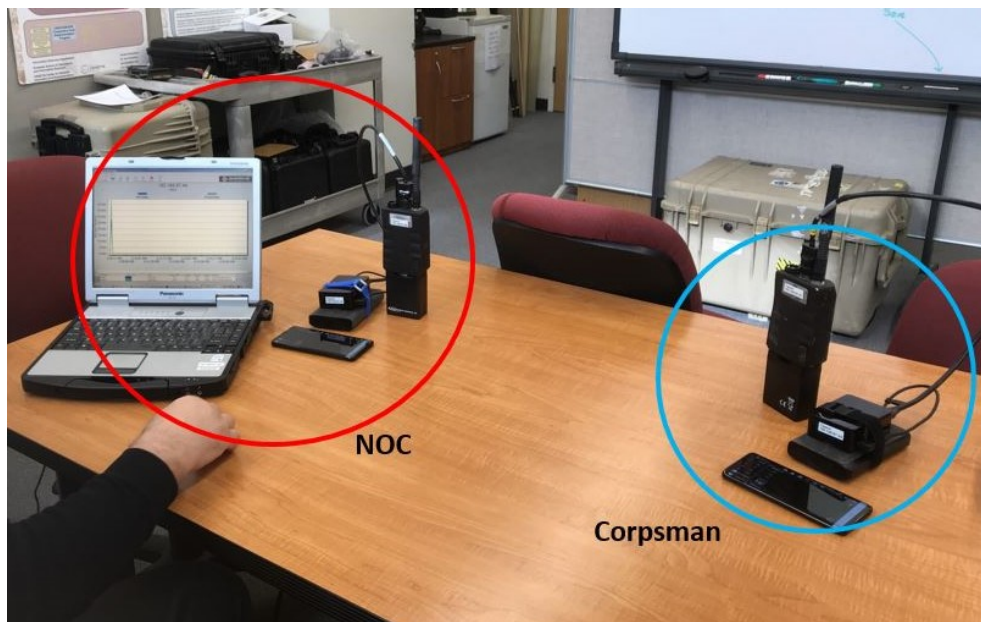

Figure 25. Initial Setup and Configuration of NOC and Corpsman

During the testing of the initial configuration, SolarWinds SNMP Real-Time Graph (RTG) was started to capture the In/OutOctets MIB. A simulated patient was established on the corpsman's BATDOK application. Data from a demonstration biosensor and pictures were relayed from the corpsman's smartphone to the NOC smartphone with the expectation that the RTG would show a change or spike of the data across the network interfaces. There was no change in the RTG, no data spike in the graph, which meant network performance was not being captured.

In the next step, it was discovered that the Android devices were skipping the SNMP agents and not sending information to them, which was necessary to relay information about the interfaces to the RTG. The initial setup was reconfigured to capture network performance metrics by reconfiguring the SNMP agent. Instead of the SNMP agent connecting to the MPU4 by its 10/100 Ethernet connection, the agent was configured to connect to the MPU4 via Wi-Fi, as shown in Figure 26.



Figure 26. MPU4 Connected to the SNMP Agent via Wi-Fi without the 10/100 Ethernet Cable

Next, the SNMP agent was configured to collect and store information from the MPU4 application programming interface. This allowed the network data and performance information to be captured by the agent for analysis.

2. Observations

When it was found that the SolarWinds was not capturing network information the SNMP agents had to be reconfigured to connect to the MPU4s and smartphones. Only using the SNMP agent provided two benefits; first, having less equipment during the experiments and second, all of the information was captured on one piece of equipment instead of having to gather information from multiple devices. Modifying the bundle allowed subsequent Phases. The Android smartphone connection remained the same and connected via Wi-Fi. The new configuration led to not having to use the SolarWinds software on a laptop to collect information in real-time.

The SolarWinds RTG and other applications were thus replaced by the SNMP agent. The SNMP agent was configured to collect and record MPU4, SNMP agent, SNR, and Global Positioning System (GPS) information, as in Table 5, throughout the experiments at three-second intervals. The information collected would be extracted as a log file for analysis.

Table 5. Information Collected by the SNMP Agent

	MPU4	SNMP	SNR	GPS
Information Collected	Date/time	Date/Time	Date/Time	Date/Time
	IP address	IP Address	Self IP Address	IP Address
	Kbps In	bps In	Self SNR (always zero)	Latitude
	Kbps Out	bps Out	Neighbor 1 IP and SNR	Longitude
		RTT (ms)	Neighbor 2 IP and SNR ¹	Altitude
		Packet Loss (%)		
		Packet Size (octets)		

¹ Each additional neighbor added will have its IP and SNR recorded sequentially.

C. PHASE II: LINE-OF-SIGHT TESTING

Following the testing and adjustment of the system configuration in Phase I, Phase II consisted of benchmark testing the demonstration software and COTS sensors and point-to-point communication between MPU4s. The MPU4s were kept in LOS.

1. Objective

The objective of Phase II was to assess which factors affect the software platform's ability to relay data across a wireless network. The concept of the experiment was to have a NOC, which had a static location, and a simulated corpsman, in a dynamic location, at the opposite end of a MANET (Figure 27) to capture patient biosensor data and relay the information to the NOC. The experiments took place on the NPS campus.

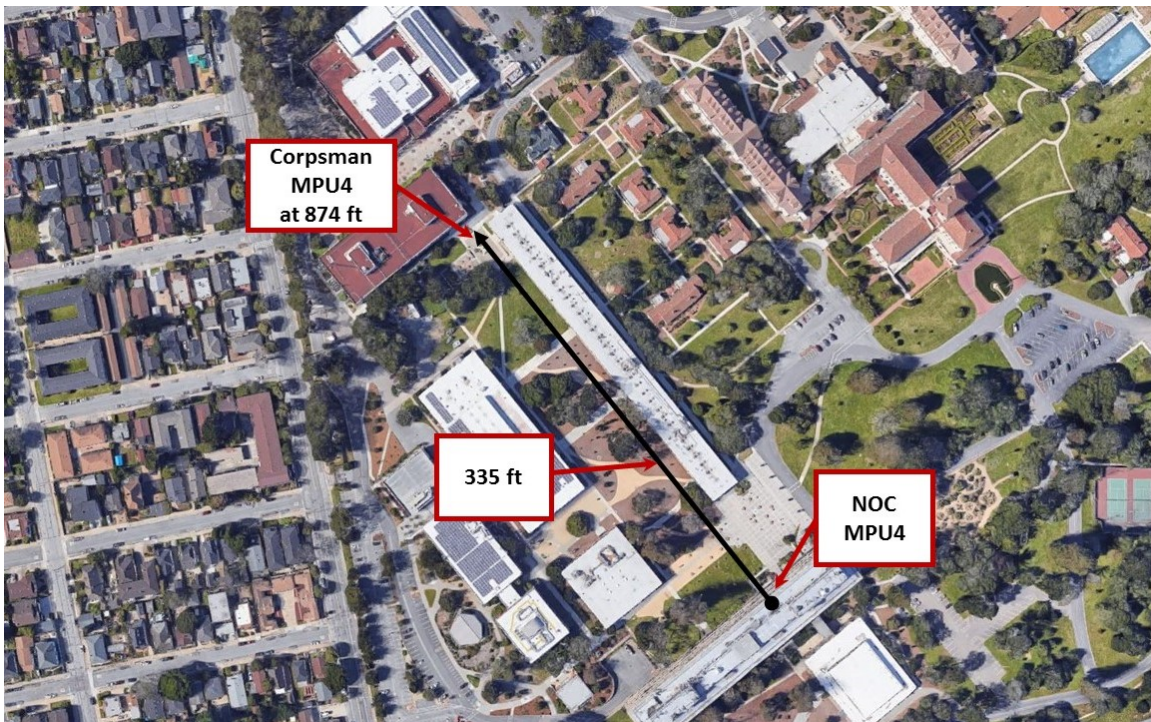

Figure 27. Nodes and Distances

2. Actions

During the experimentation, the NOC, as described previously, was located on the rooftop of Spanagel Hall, Figure 28. A desktop computer was connected to the NOC MPU4 by a 10/100 Ethernet to verify data was captured during the experiments. Two distances were selected for the initial MANET network connection testing. Two researchers assisted with receiving and verifying the data transmission during the experiments.



Figure 28. Roof of Spanagel Hall

The other smartphone was kept by me acting as a corpsman in field environment. The corpsman's smartphone was connected to a MPU4 via Wi-Fi and another SNMP agent was connected to the MPU4 via Ethernet cable. Both SNMP agents were powered by an external battery.

a. Step 1

The initial distance, of 335 ft, was selected because it was the first location that was visible from the roof of Spanagel Hall, which allowed for LOS benchmark testing. The objective was to initiate a connection between MPUs and be able to ping the four IP addresses of the equipment—two MPU4s and two Raspberry Pi computers. First, a connection was

initiated between two MPU4s, in a direct line of sight and at a short distance. Each MPU4 was fitted with a 2.1–2.5 GHz radio frequency (RF) antenna. The computer connected to the MPU4 at the NOC sent and verified the pings. The equipment worked as expected. No patient data was transmitted from the smartphone.

b. Step 2

Given the successful test at the first distance, the next objectives were to increase the distance between the nodes, maintain MPU4 connectivity, and transmit patient information and data within the established MANET. The distance of 874 ft was selected to keep a LOS between the MPU4s and not place an obstruction between the nodes.

Once a connection between the MPU4s was established, the Android smartphones running the BATDOK software were connected to the MPU4s through Wi-Fi. A maximum of four patients were entered into the corpsman’s BATDOK software application, two for demonstration sensors and two for separate Bluetooth biosensors. The COTS biosensors used were the Masimo MightySat pulse oximeter and the Polar H10 heart rate monitor. Two patient entries from the smartphone screenshot are shown in Figure 29.

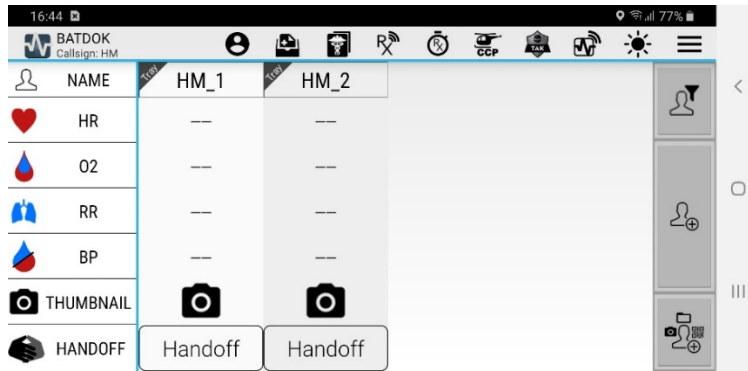

Figure 29. Two Patients Displayed in BATDOK on the Samsung S9+ Smartphone

c. Step 3

Once all of the connections were established and verified, patients were added in the corpsman BATDOK and given a name and an associated biosensor, either a demonstration

sensor or a COTS sensor. The specified names and sensors, Table 6, were kept throughout the durations of the experiments as a means to identify network performance during analysis.

Table 6. BATDOK Names and Corresponding Sensors

BATDOK Patient Name	Sensor Configuration
HM_1	Demonstration Sensor
HM_2	Demonstration Sensor
HM_3	Polar H10 Heart Rate Monitor
HM_4	Masimo MightySat Pulse Oximeter

In order to test the performance and network throughput, network performance information was collected from the MPU4 interfaces and collected at the SNMP agents for analysis. The data transmitted consisted of patient vital signs and photos taken and recorded by the corpsman smartphone running the BATDOK application. The information on the corpsman smartphone was to show up on the NOC smartphone at the opposite end of the network automatically. The network performance and data collection was captured by SNMP agents running on Raspberry Pi computers, as seen in Figure 30.

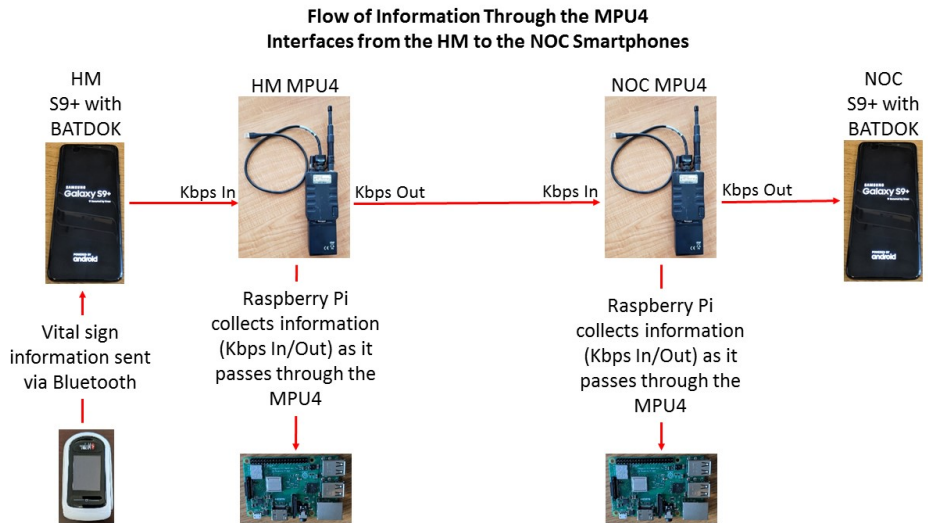

Figure 30. Flow of Network Information

3. Observations

Initially, at the first distance of 335 ft, the MPU4s connected as expected and the MPU4s connected and when a ping was sent a response was received. When moved to the second distance, 874 ft, the MPU4s then began to intermittently lose connection with each other and had difficulty staying connected. The MPU4s did not perform as expected. Data could not be transmitted between smartphones without repeatedly having to re-establish the connection. To solve the connection issue, two MPU5s were added to the network, one next to each MPU4, one placed at the NOC and one with the corpsman, Figure 31. Each MPU5 was configured with three RF antennas. With the addition of the MPU5s, a mesh network was created instead of two nodes as originally planned. Although the distance between a MPU4 and MPU5 at each end was negligible, the MPU5s, with better RF antennas, assisted by keeping the MPU4s connected.

With these changes, patient data, including vital signs and pictures, were transmitted from the corpsman's smartphone to the NOC smartphone. Adding the MPU5 to each end of the network was a key contributor to the MPUs maintaining connectivity.



Figure 31. MPU4, SNMP Agent and Battery (left) and MPU5 (right) with the Corpsman

Each sensor for BATDOK had its own Android Package Kit (APK), in BATDOK version 2.6.5.7 and earlier, and as one APK file containing all of the sensors, in version 3.0.4 and beyond. An APK are program files necessary to install and use applications (Stegner, 2017, para. 2). As mentioned in Phase II observations, the Polar H10 heart rate monitor initially connected, and displayed data, to all three EUDs; the Samsung S5, the ST85, and the Samsung S9+. Between the end of Phase I and the second distance experimentation of Phase II, the Polar H10 stopped connecting to the BATDOK application running on the S9+. A sensor error message was received each time an attempt was made to add the sensor to a patient, as shown in Figure 32, and the green connection light would not stay lit but blinked intermittently from gray to green.

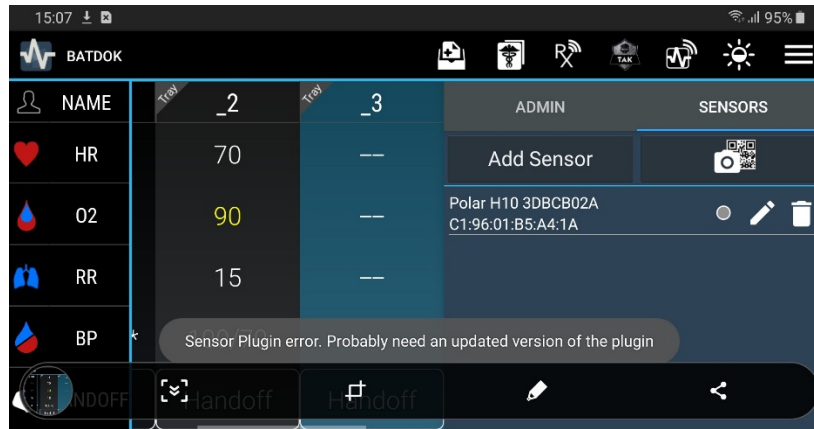

Figure 32. Polar H10 Plugin Error Message

The answer to the cause of the incompatibility is unknown. Although, the error message states “Probably need an updated version of the plugin,” the version used was the most recent one available at that time. Another possibility is that the S9+ may have received an Android software update which led to the Polar H10 not connecting. Only BATDOK demonstration sensors and the Masimo MightySat pulse oximeter were used for the remaining experiments. Patients HM_1, HM_2, and HM_3 were assigned BATDOK demonstrations biosensors and HM_4 was connected to the MightySat.

Vital signs, both demonstration and Bluetooth connected biosensors, and pictures were passed along the MANET while both nodes were in LOS of one another. The SNMP

agent captured network performance. The two large spikes represent two separate pictures taken, as seen in Figure 33, with the HM smartphone running BATDOK. Picture #1 was attached to the patient HM_1 and picture #2 was attached to patient HM_2. Picture #1 had a peak network throughput of 197 Kbps when it entered the MPU4 interface and a peak of 82 Kbps when it exited. Picture #2 had a peak of 130 Kbps when it entered the MPU4 interface and a peak of 52 Kbps when it exited. It is unknown if the peaks are 100% accurate, but doubtful, because SNMP agent only polled the MPU4 interface every few seconds. As an example, there are 6 seconds before the peak of 197 and 2 seconds after the peak of picture #1 when data was collected. It is unknown if the throughput was higher during the times not collected; and the same for picture #2 peaks.

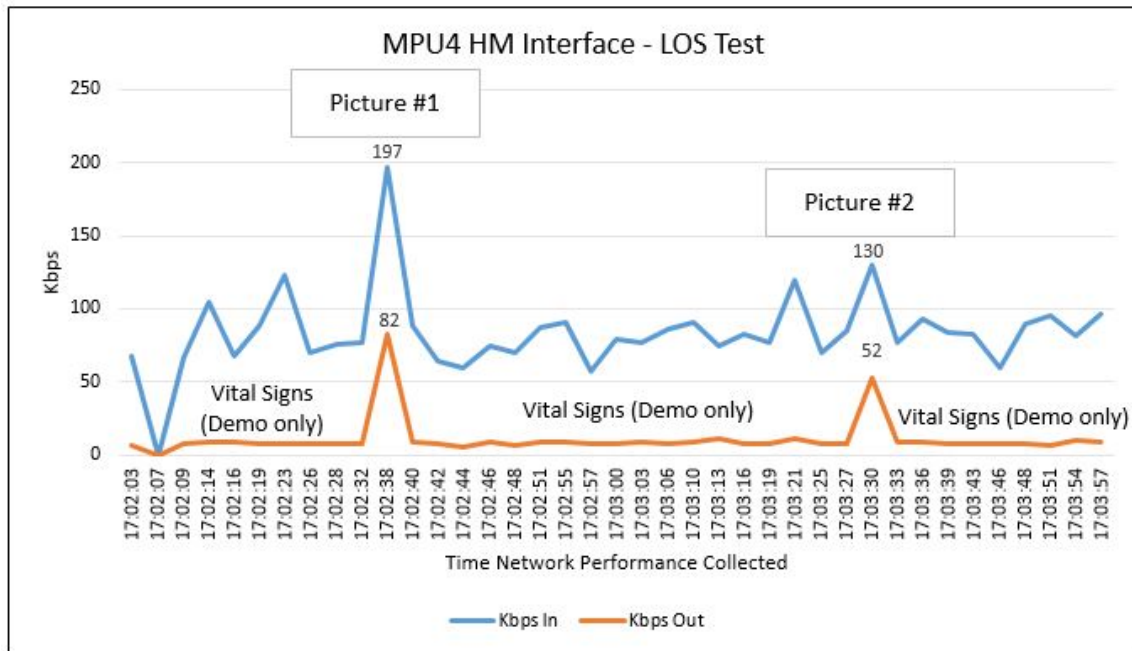

Figure 33. LOS Test–Network Throughput at the HM MPU4









BATDOK Callsign: Spanagel		Tray	Tray
NAME		HM_1	HM_2
 HR		62	79
 O2		90	91
 RR		12	13
 BP		107/77	95/66
 THUMBNAIL			
 HANDOFF		Handoff	Handoff

Figure 34. Pictures Attached to Patients

The network throughput before, between, and after the pictures consisted of vital sign information from a BATDOK demonstration sensor attached to each patient, HM_1 and HM_2. The demonstration sensor vital sign information was captured and logged every minute by the HM BATDOK and received by the NOC BATDOK. The vital signs that correspond with Figure 33 are displayed in Figure 35.



Figure 35. Vital Signs Received on the NOC BATDOK

Figure 36 depicts the SNR collected by the SNMP agent during the same timeframe as the network throughput performance was captured before, during, and after the pictures were taken and transmitted. The SNMP agent recorded the SNR of all MPU4s and MPU5s that were connected to it in the MANET. The SNR between the MPU4s was not low enough to impact performance. Although the SNR value to the MPU5s was not important, it was included as a representation of how the distance between tactical radios affects SNR. The HM MPU4 and HM MPU5 were inches apart during the LOS test and the SNR remained consistent at low 90 dBs during the transmission of vital signs and pictures, while the NOC MPU4 and MPU5 was 874 ft apart and the dB levels were much lower in the high 40s and mid 30s dB ranges. The average SNR from the HM MPU4 to the NOC MPU4, shown as the orange line in Figure 36, was 34 dBs.

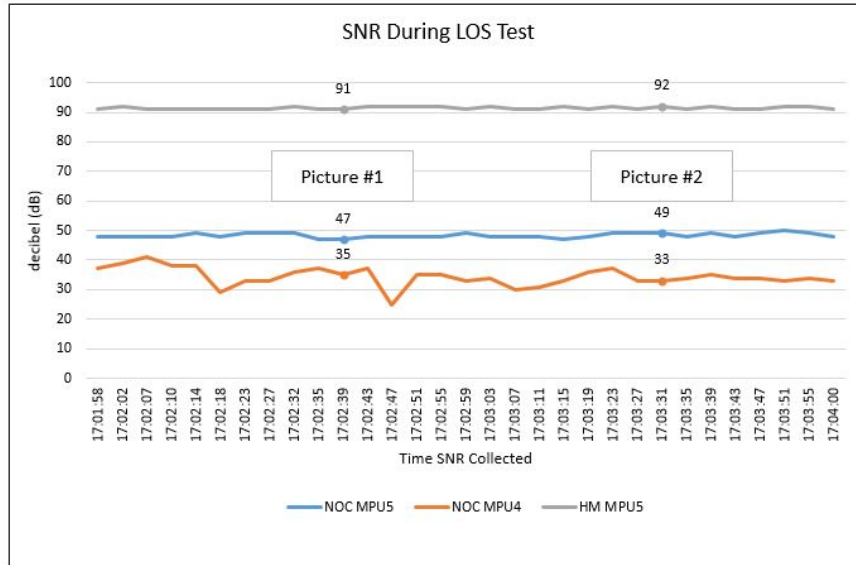

Figure 36. SNR from the HM MPU4 LOS Test

Although the SNR decreased from when pictures #1 and #2 were taken, the MightySat assigned to patient HM_4 transmitted data via BATDOK and the MPU4s, as seen in Figure 37. Enough data was sent and captured to sufficiently analyze and proceed to beyond LOS (BLOS) testing.

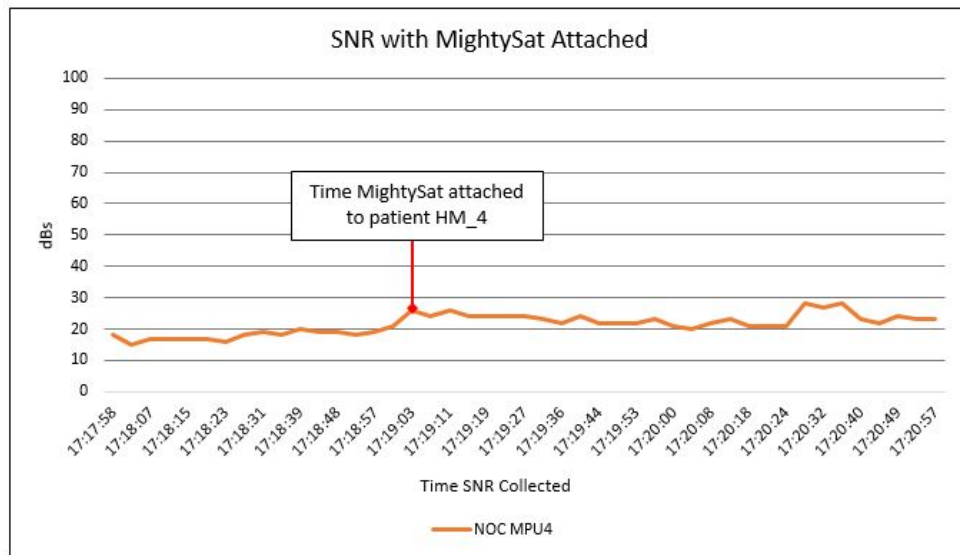

Figure 37. SNR from the HM MPU4 with the MightySat





NAME	HM_3	HM_2	HM_4	HM_1
HR	58 *	68	55 *	78 *
O2	X *	93	98 *	92 *
RR	18 *	13	X *	17 *
BP	180/87 *	98/77	X/X *	92/63 *
THUMBNAIL				
HANDOFF	Handoff	Handoff	Handoff	Handoff

Figure 38. MightySat Vital Signs Visible at the NOC

D. PHASE III: BLOS TESTING

In this discovery testing Phase, we transmitted data on the network BLOS to the roof of Spanagel Hall from the northeast side of Root Hall, 705 ft as in Figure 39. Phase III took place on the NPS campus. The location for the corpsman node was selected to place a large obstruction between the two nodes.

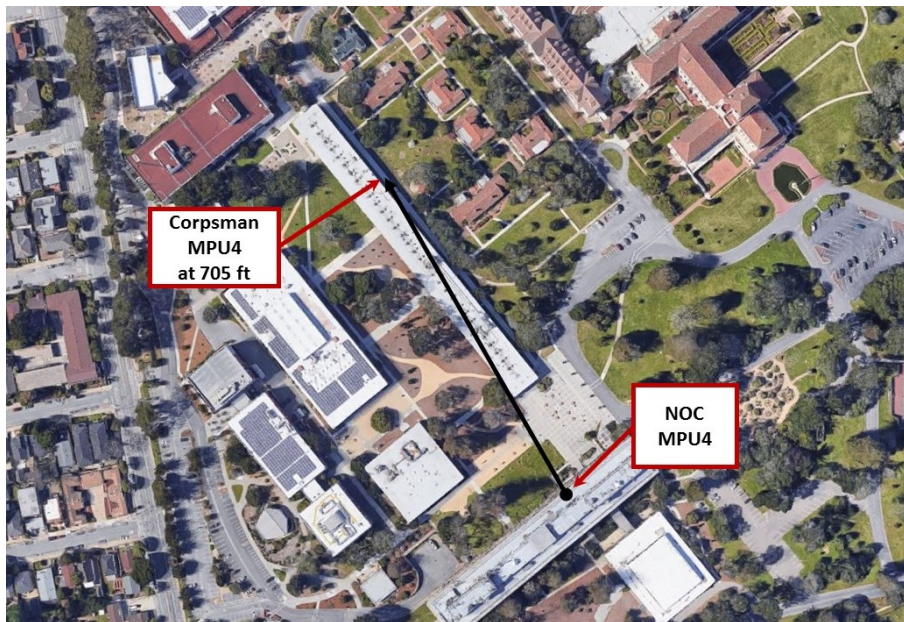

Figure 39. BLOS Testing

1. Objective

In Phase II it was determined that the MPU4s could transmit patient data in LOS between each other. The objective of Phase III was to determine whether the mesh network could transmit patient data from one end to the other BLOS. In a real-life situation, a corpsman may not be in the LOS of the other node or there may be an obstruction in-between the corpsman and the NOC such as building or walls in an urban area, as in Figure 40. Therefore, to assess the feasibility of the system, a building was placed between the corpsman and NOC node for BLOS testing.

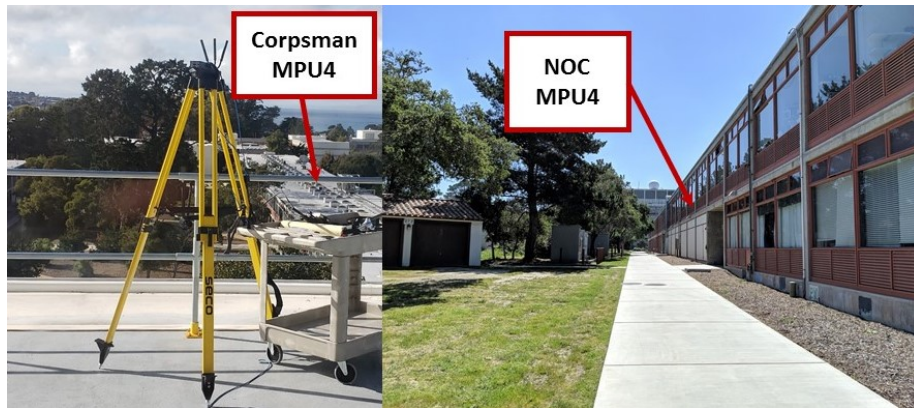

Figure 40. View from MPU4 Locations

2. Actions

During the experimentation, the NOC was constituted as in Phases II and III. A desktop computer was connected to the NOC MPU4 by a 10/100 Ethernet to verify data was captured during the experiments. The location for the corpsman bundle was selected to ensure the corpsman MPU4 and NOC MPU4 were BLOS of one another. Two researchers assisted with receiving and verifying the data transmission during the experiment at the NOC. The four patients in BATDOK from Phase II were used in this Phase. Patient vital sign information and pictures were sent from the corpsman's smartphone to the NOC smartphone as in the previous Phase.

3. Observations

The difference between LOS and BLOS testing was that network had to transmit data with a building placed in-between the two end nodes. The smartphone at the NOC received the vital sign information and pictures sent from the HM BATDOK. Vital signs and two pictures, #3 and #4, were taken and transmitted during Phase III. The variance of network throughput during the transmission is depicted in Figure 41. Picture #3 had a Kbps In of 161 and a Kbps Out of 54 and picture #4 174 and 57 respectively. Once again, the peak Kbps transmission was not enough to nearly load the MPU4 maximum throughput.

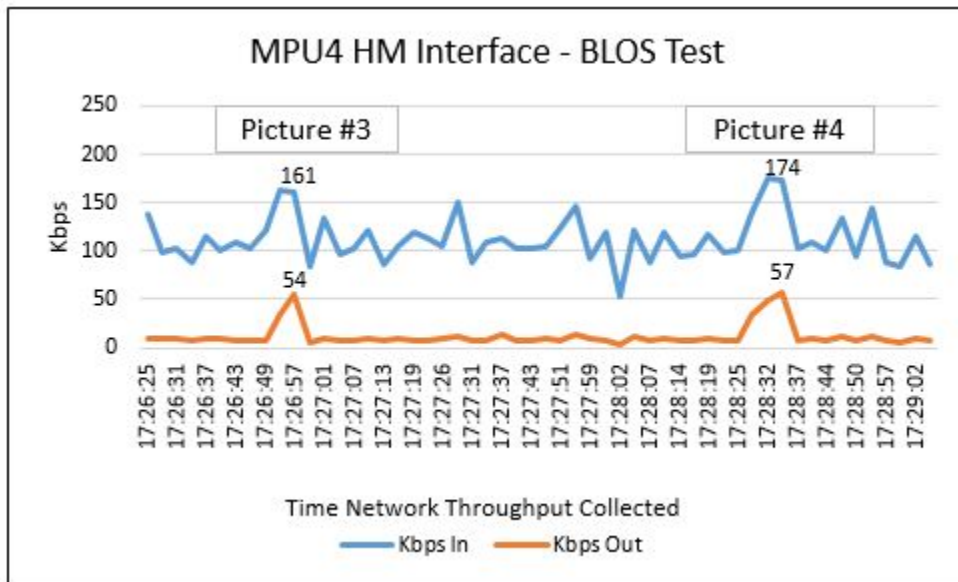

Figure 41. BLOS Test Network Throughput

During the BLOS test of vital sign and picture transmissions, the SNR reduced to an average of 17 dBs from the LOS average of 34 dBs, as shown in Figure 42. The network performed better than expected given the fact that the nodes were BLOS of one another. The data transmitted and received was sufficient to analyze and proceed to Phase IV.

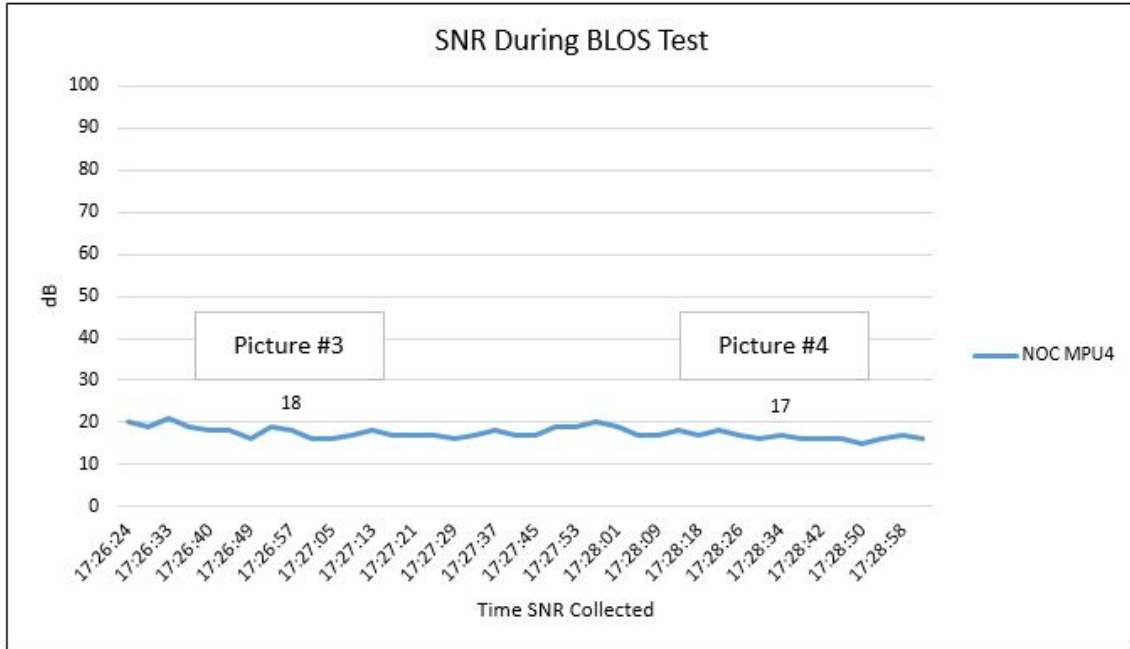

Figure 42. SNR from the HM MPU4 during BLOS Test

E. PHASE IV: DISCOVERY IN A MESH NETWORK

Phase IV built upon the testing completed in Phase III and increased the length of the mesh network and added a relay node to better represent a field environment in which a corpsman may use multiple radios for reach back capabilities in a MANET. The MPU4s did not have a clean LOS; there were primarily trees between the nodes. As in Phase III, the demonstration sensors and MightySat were used and vital signs were automatically logged every minute.

1. Objective

The objective was to assess whether incorporating a relay node to the network would affect patient biosensor data transmission in an application platform solution. The concept of the experiment was similar to Phase II; there was a NOC and a simulated corpsman at each end of a MANET, with the introduction of a MPU4 in the middle. The experiment took place on the NPS campus, Figure 43. The nodes used were MPU4s and MPU5s, the same as in Phase III. Each end node, the NOC and corpsman, was a bundle—

a MPU4, a Raspberry Pi, and an external battery to power the Pi. Each end node also had a MPU5 next to it.



Figure 43. Phase IV MPU4 Locations

2. Actions

During this Phase, the distance between the corpsman node and the NOC node was extended until the corpsman node lost its connectivity to the NOC, at approximately 1,600 ft. Once the connection was lost, I returned toward the NOC node until the network connection was re-established. An additional MPU4, to relay data between end nodes, was placed at the location to maintain the connection to the NOC MPU4 at 1,524 ft, as seen in Figure 44.



Figure 44. MPU4 Relay Node

Next, the corpsman MPU4 bundle and smartphone were taken a further distance away from the relay node to extend the network. Again, the four patients established in BATDOK for previous Phases were used to send data from the corpsman MPU4 to the NOC MPU4 on the roof of Spanagel through the mesh node placed between. The data consisted of patient vital signs and multiple pictures.

Two separate tests were completed at the same distance. The first test sent vital signs and a picture (#5) through the mesh in order to see if it was received in the NOC. The second test took and sent 10 pictures as quickly as possible, while transmitting vital signs, to try to increase the amount of data transmitted through the mesh network.

3. Observations

Upon filtering the log files for SNR data, it was found that the MPU4s at each end could only see the relay node. When the SNR data was filtered to view what the relay node can capture, it saw the SNR dBs of both end nodes (Figure 45) which verified that the relay node was transmitting data within the mesh and the end nodes were not skipping over the relay node and making a one-to-one connection. The SNR from the NOC to the relay MPU4 was slightly lower than the relay to the HM, and that may have been because of the

difference in distances; from the relay to the NOC was 1,524 ft and from the relay to the HM2 was 402 ft.

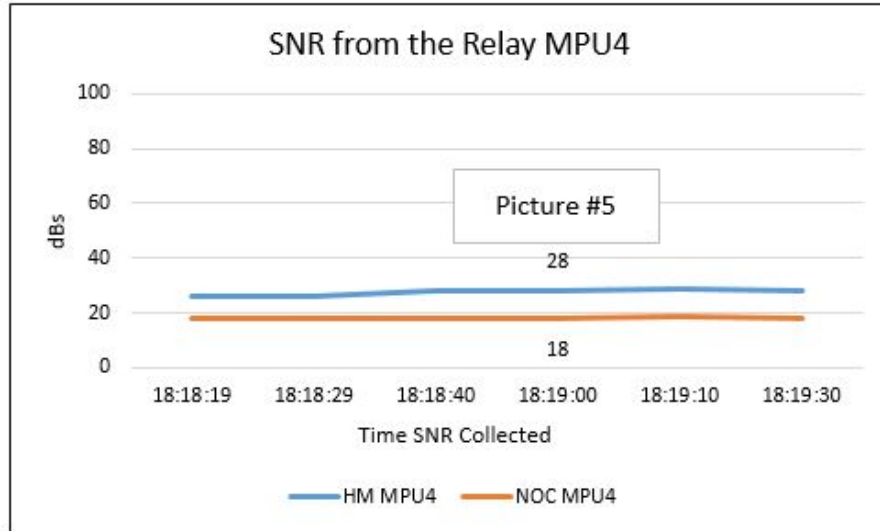

Figure 45. SNR from Relay MPU4

The first test, of vital signs and picture #5, produced similar network throughput results as previous Phases, as seen in Figure 46. The peak Kbps In was 100 and the peak Kbps Out was 37 while data was sent to the NOC.

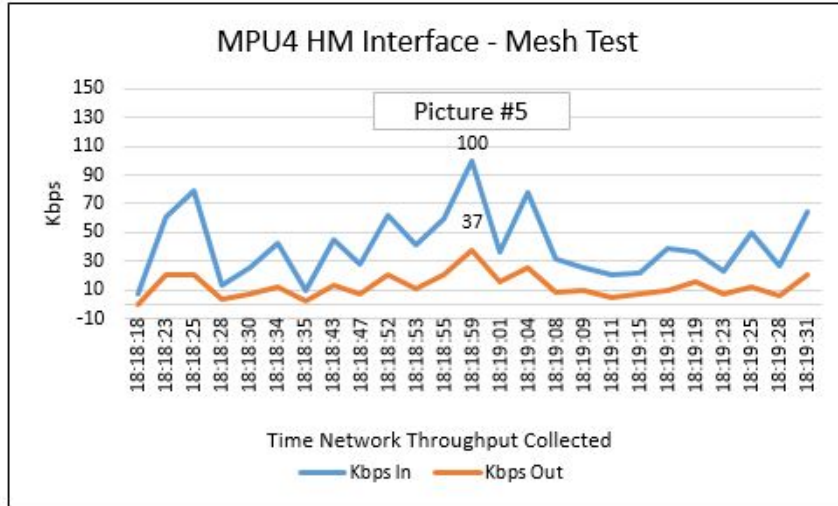

Figure 46. Mesh Test Network Throughput

A series of 10 pictures were taken from the HM BATDOK successively in an attempt to flood the network and increase throughput into the network. As seen in Figure 47, no spike in data went above 220 Kbps. It was also difficult to discern which pictures were sent at what time because the goal was to send them as soon as possible. Vital signs measured and sent at the same time had no significant bearing on the throughput as well.

Placement of a relay node in-between the HM and NOC MPU4s created a mesh network for the transmission of patient vital signs and a picture. The mesh network performed as expected, at a greater distance and with a node placed between the mobile and stationary MPU4s. The data transmitted and received was sufficient to analyze and proceed to Phase V.

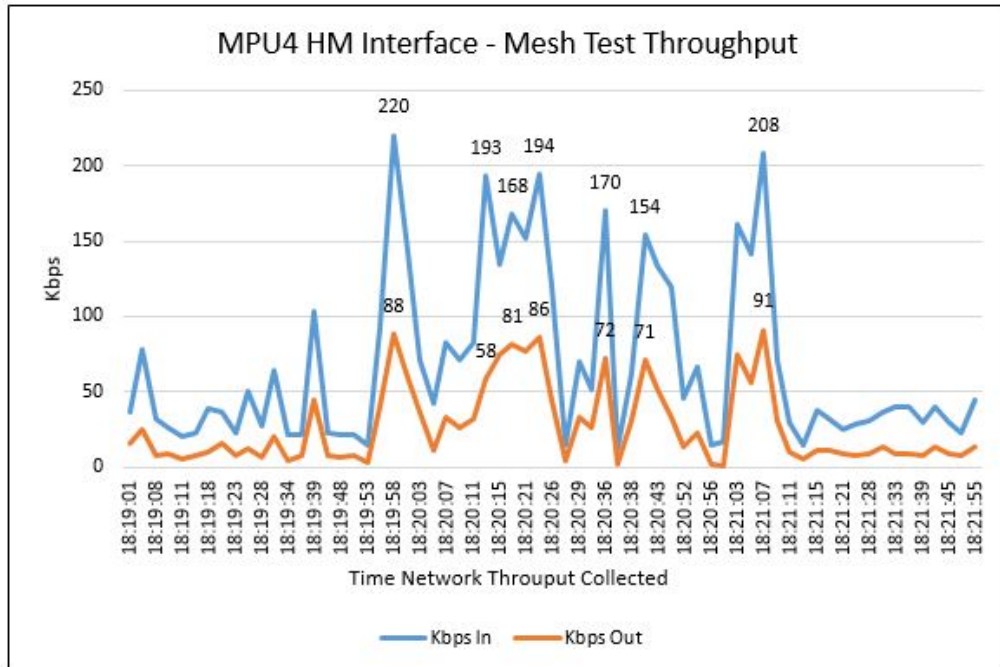

Figure 47. Mesh Test Network Throughput of 10 Pictures

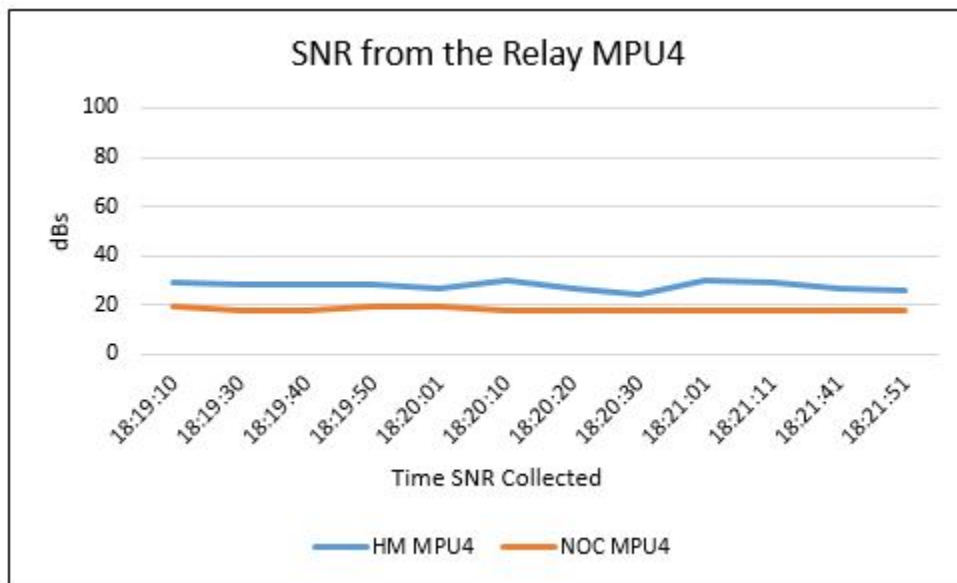

Figure 48. SNR from the Relay MPU4 to End Nodes

F. PHASE V: INCREASED DISTANCE OF A MESH NETWORK

Phase V built upon the testing completed in Phase IV and increased the length to better represent a field environment a corpsman may find themselves in during a tactical situation when using a MANET.

1. Objective

The objective of this final Phase of testing—and the primary objective of this research—was to assess if there is a viable platform solution to improve the monitoring and mortality rate of injured personnel in an austere environment within a MANET. The concept of the experiment was similar to Phase IV: there was a NOC and a simulated corpsman at each end of a MANET, with a node in the middle. The experiment took place on the NPS campus, along the Monterey Bay waterfront, and in Monterey Bay, Figure 49. The NOC was situated on the roof of Spanagel but in a scenario where the corpsman was treating a casualty ashore then the locations would have been reversed. The corpsman would have been on Spanagel and he would relay the information to a ship in Monterey Bay through a node on the Municipal Wharf. The focus was not where the NOC and corpsman were located, or the direction of the data flow, but that patient data could be sent an extended distance than what was previously accomplished in Phase IV.



Figure 49. Locations of MPU5 Nodes

The nodes used were all MPU5s. MPU4s were no longer used, partly because of the limited capability of distance found in previous Phases and because a NPS researcher had configured the SNMP agent as a Wi-Fi access point for the smartphones to connect to between Phase IV and this Phase. Each end node was a bundle—a MPU5, a Raspberry Pi, and an external battery to power the Pi, Figure 50.



Figure 50. MPU5 Bundle (MPU5, External Battery, and Raspberry Pi)

2. Actions

During this Phase, the distance between the NOC node and the relay node was approximately one mile and was static; from the roof of Spanagel Hall on the NPS campus to the Monterey Municipal Wharf II. The corpsman node was onboard the U.S. Coast Guard Station Monterey Motor Life Boat (MLB) 47321. A laptop was taken on the MLB to check the connections to the other equipment by using the ping command and to use the Persistent Systems Interface Management access to the MPU5 and node information.

First, the network connection was established between the MPU5s prior to leaving the NPS campus and heading to the Municipal Wharf. Once a connection on campus was confirmed, I went to the Municipal Wharf and confirmed again that the network connection remained. The node from the Wharf to the roof of Spanagel was maintained in LOS. After

verifying the connection, the relay node was turned on and its connection was verified. The computer at the NOC was able to ping both the relay and corpsman nodes.

The relay node remained on the Municipal Wharf while the corpsman MPU5 bundle was taken onboard the USCG MLB 47321. Once onboard the MLB, I was taken out into Monterey Bay. At different distances the nodes used in the experiment were pinged to verify connections. Vital signs were taken using the MightySat and two pictures were relayed to the NOC at Spanagel Hall.

3. Observations

The Node Pinger, running on the laptop taken on the MLB, maintained connections at close distances to the pier but had intermittent connectivity at further distances most likely because of the increased rough sea state encountered further from the shore. Figure 51 is a graph depicting the connectivity seen at 3.85 miles from the wharf. As expected the SNMP agent and MPU5, IP addresses 42 and 92, had a constant connection as there was virtually no distance between them. The rest of the MPU5s and the NOC SNMP Agent connected but were unable to maintain a consistent connection visible by the yellow and red boxes in the graph.

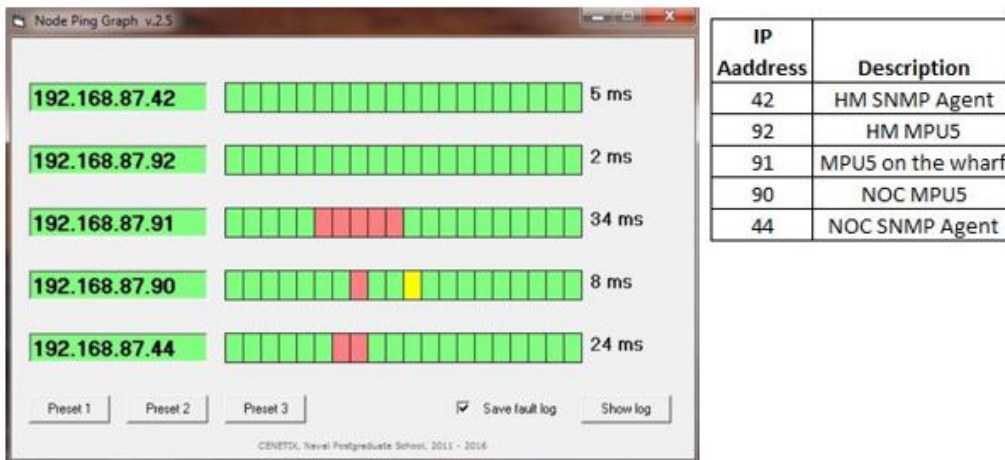

Figure 51. Node Ping Graph of the MPU5s and SNMP Agents

It was difficult to maintain bearing on the wharf's location. Because of inclement weather and time constraints, only one patient was established in BATDOK to send data from the corpsman smartphone and MPU5 to the stationary NOC smartphone and MPU5 on the roof of Spanagel through the MANET. The data consisted of patient vital signs and two pictures. The NOC BATDOK received the vital signs and the photographs. The network performed as expected at a greater distance with a node placed between the mobile and stationary MPU5s.

Phase V was completed in conjunction with a pair of NPS students who also experimented with network throughput of the MPU5s. After the log files were downloaded from the SNMP agents and filtered, it was found that the smartphones and the MPU5s did not have the same time. This made it impossible to accurately filter the data to analyze the network throughput and SNR. There was not sufficient means and time to complete another mesh network test from the NOC, located at NPS, out to Monterey Bay. The next chapter analyzes and summarizes the log files captured by the SNMP Agents collected throughout Phases II, III, and IV.

IV. ANALYSIS

This chapter analyzes the results of the experiments implementing BATDOK in a MANET obtained in Chapter III. It provides the analysis of the software platform's ability to improve monitoring and mortality rate of injured personnel in an austere environment using a MANET and provides the findings of how the software platform integrates with biosensors in a MANET. Overall, the experimentation revealed that BATDOK performed well within the constraints of a mesh network

A. LOS TESTING

At a distance of 874 ft, the HM BATDOK was successfully able to relay patients' vital-sign information through the MPU4s with the assistance of the MPU5s. Automatically logged vital signs every minute, with or without pictures, would not reach the maximum throughput of the MPU4 of 27 Mbps. Given the low amount of throughput when vital signs are captured, if BATDOK had the ability to capture vital signs every 10 seconds it would not negatively affect the network. The SNR levels were sufficient to transmit the data given the distance and while maintaining LOS during the test; this may have been because a MPU5 was added to each end of the network in order to give a boost to the MPU4 antennas. Another factor contributing to the successful transmission of data may have been the elevation of the NOC, which resulted in less interference at ground level.

B. BLOS TESTING

Although the BLOS location selected was 169 ft closer to the NOC than the LOS test, the SNR decreased by 17 dBs. Despite the SNR decreasing relative to the LOS test, the patient information was transmitted from the HM BATDOK back to the NOC BATDOK. Most likely the network would not have been able to relay the data if the MPU5s were not present since the MPU4s had difficulty sending data by themselves during the LOS test. The SNR reduction was most likely caused by the building obstruction. The testing of the network throughput included vital signs from four patients and two pictures. As was found during the LOS test, the overall throughput captured during the two and a

half minutes was not significantly high but did not negatively affect the data transmission. The BLOS test is similar to a patrolling operation in an urban setting where buildings are the major contributor to not keeping a LOS.

C. MESH NETWORK

Adding a relay MPU4 between the NOC and HM created a MANET for information to be passed through, which corpsmen might require during an operation with Marines. The two tests performed during the mesh-network phase produced similar results as the previous phases. The amount of data sent through the network did not hinder the network's ability to transmit information, and even though the SNR was low during extended distances, the data was received at the NOC. The distance achieved reinforces the concept that a tactical unit's MANET may have to extend a great distance to contact reachback assistance, potentially necessitating a relay. Although no data was analyzed from attempting to transmit data from Monterey Bay, a MANET network connection was made at much greater distance than the mesh network test completed on the NPS campus.

D. NETWORK THROUGHPUT AND SNR CONCLUSIONS

During each Phase, data was sent through the network; from end-to-end in LOS, BLOS, and a mesh with a relay. The throughput was analyzed to verify if the information passing through the MPU4 tactical radios would place a large load on the network. As seen in Table 7, the highest Kbps achieved throughout all of the testing was 22% of 1 Mbps. This is an extremely small percentage of the MPU4's maximum throughput of 27 Mbps. The multiple vital signs and pictures passed via the network were not enough to have any negative effects on the network and would not have place a burden on a small team's MANET in an operational environment.

Table 7. Maximum Kbps Achieved through the HM MPU4 during Tests

Phase	Test	Kbps In (High)	% of 1 Mbps	Kbps Out (High)	% of 1 Mbps
II	LOS	197	20%	82	8%
III	BLOS	174	17%	57	6%
IV	Mesh	100	10%	37	4%
V	Mesh (10 pictures)	220	22%	91	9%

The SNR seen throughout the Phases were high enough to not affect the data transmission. The higher position, approximately 85 ft from the ground, of the NOC throughout the tests, where the NOC MPU4 was located most likely led to a higher SNR than if the NOC were located on the ground where the relay and HM nodes were located. The NOC at a height of 85 feet could have represented a small hill in which someone trying to receive or send data in an austere environment may find themselves.

E. RESEARCH QUESTIONS

This section answers the research questions based on the experimentation and their analysis. The research questions are as follows:

- What factors affect a software platform’s ability to process data from multiple biosensors?

It was identified that compatibility is essential to testing the software platform with multiple COTS biosensors, as one of the COTS biosensors connected and transmitted patient data initially and then stopped working during later Phases. Installing BATDOK on older equipment, such as the Samsung Galaxy S5, proved unreliable and did not sufficiently make the best use of the experiments. Ensuring consistent connections to the transmission equipment is being used is essential.

- What factors affect data flow in a MANET with a software platform and biosensors?

MPU4s were the primary means of relaying data through the network. Similar to older equipment affecting BATDOK’s ability to process data, the MPU4s proved to have

limited range; therefore, the MPU5s were introduced alongside each end node in order to boost their range.

- How does an influx of patient data affect MANET throughput?

An attempt was made to flood the network with vital signs in addition to multiple pictures transmitted consecutively. The network managed the transmission of increased data throughput and the amount of data was nowhere near the limits of the MPU4's throughput.

- Is there a viable software platform solution to improve the monitoring and mortality rate of injured personnel in an austere environment within a MANET?

BATDOK is a viable platform solution to improve the monitoring and mortality rate in an austere environment. Different BOTS biosensors from multiple manufacturers must be tested to verify the options are available for use in an austere environment. Corpsmen operating BATDOK in an austere environment may focus more of their time and resources to saving lives when finding themselves as the sole medical provider during an operation.

V. CONCLUSIONS AND FUTURE RECOMMENDATIONS

This chapter provides concluding thoughts on a software platform used to monitor and relay patients' vital signs and employing a MANET to relay information and makes recommendations for future research in the area of medical biosensors integrated in a mesh network.

A. SIGNIFICANCE

The purpose of this study was to analyze the ability of a software platform (BATDOK) to improve the monitoring and mortality rate of injured personnel in austere environments using a MANET. Based on this research, I was able to find that a software platform, such as BATDOK, is a viable solution to improve the monitoring of injured personnel in an austere environment. However, further research with additional compatible COTS biosensors must be completed to determine further efficacy of a corpsman utilizing biosensors in an austere environment.

B. LIMITATIONS

An objective of this study was to test COTS biosensors from different manufacturers. Finding out early during experimentation that the Polar H10 heartrate monitor stopped connecting to BATDOK narrowed the scope of experiments after Phase I. Given the network throughput results of the MightySat and demonstration sensors, the H10 would most likely not have increased the throughput by a tremendous amount but it would have been beneficial to show the connection, relay, and data through the MANET.

Not having the ability to connect the two smartphones to the MPU5s at the beginning of the experiments hindered the MANET; during the LOS and BLOS testing the MPU5 was used to extend the MPU4's range. Utilizing an older version of the Man Portable Unit (MPU4) for all of the testing was not the best use of a mesh network. The experiments showed how beneficial the MPU5's three RF antennas are when communicating in a mesh network.

C. FUTURE WORK

The motivation for this study was that Navy corpsman may find themselves in an austere and network-contested environment and need to treat multiple patients at one time and may find themselves overwhelmed. Being able to provide care to all of them while relaying pertinent health information and interventions to a higher echelon of care or decision-making medical subject matter expert is important to saving lives.

There was not a COTS biosensor tested during the experimentation that captured all vital signs, therefore multiple COTS biosensors were necessary which were not tested during this research due to compatibility issues described in Chapter III. There are also different options for creating a network in an austere environment additional research. The following list has possible ideas for future research:

- Identifying and testing compatible additional COTS biosensors that connect to BATDOK would expand the patient vital sign information that could be captured in an austere environment.
- Similar experimentation using the MPU5, with its multiple RF antennas and greater range between nodes, would be beneficial in extending the mesh network range.
- Experimenting from land to sea or a shipboard environment would prove beneficial for the demands of where Navy corpsman who may find themselves treating patients not only on land.
- BATDOK has the ability to connect and transmit via a goTenna mesh. Exploring data transmission in a burst-type communication device that operates “off-the-grid” is an option for communicating in an austere environment.

LIST OF REFERENCES

- Athena GTX. (2018). *Wireless vital signs monitor operator's manual*. Johnston, IA: Author. Retrieved from <https://athenagtx.com/wvsm-documents/>
- Baker, N. (2005). Zigbee and Bluetooth strengths and weaknesses for industrial applications. *Computing & Control Engineering Journal*, 16(s), 20–25. Retrieved from <https://ieeexplore.ieee.org/xpl/tocresult.jsp?isnumber=31235&punumber=2218>
- Bluetooth. (n.d.). Origin of the Bluetooth name. Retrieved from <https://www.bluetooth.com/about-us/bluetooth-origin>
- Buller, M. J. (2010). Systems architecture. In Research and Technology Organisation (Ed.), *Real-time physiological and psycho-physiological status monitoring (2-1-2-8)*. Brussels, Belgium: North Atlantic Treaty Organization.
- Burnett, G., Bragg, I., Feibus, D., & Mack, C. (2018). *BATDOK user guide*. 711 Human Performance Wing, Airman Systems Directorate, BATMAN Program, Wright Patterson AFB, Ohio.
- Capnograph. (n.d.). In *Merriam-Webster*. Retrieved February 4, 2019, from <https://www.merriam-webster.com/dictionary/capnograph>
- Convertino, V. A., Buller, M. J., Freund, B. J., Albert, S. V. (2010). Physiological monitoring combat casualty care. In Research and Technology Organisation (Ed.), *Real-time physiological and psycho-physiological status monitoring (3-6-1-3-6-10)*. Brussels, Belgium: North Atlantic Treaty Organization.
- Department of Defense. (2018). *Summary of the 2018 National Defense Strategy of the United States of America*. Washington, DC: Author.
- Dickey, N. (December 20, 2012). Health Board. (2012). *Battlefield Medical Research, Development, Training and Evaluation Priorities, 2012–08* [Memorandum]. Falls Church, VA: Defense Health Board. Retrieved from <https://health.mil/Reference-Center/Reports/2012/12/20/Battlefield-Medical-Research-Development-Training-and-Evaluation-Priorities>
- Dorsch, J., & Burnett, G. (2018). *Battlefield assisted trauma distributed observation kit*. Uploaded to YouTube.com, San Bruno, CA. Retrieved from <https://www.youtube.com/watch?v=FqB2uBu7aYU&feature=youtu.be>
- Eastridge, B. J., Mabry, R., Blackbourne, L. H., & Butler, F. K. (2011). We don't know what we don't know: Prehospital data in combat casualty care. *The United States Army Medical Department Journal* (April–June), 11–14.

- Electronicsnotes. (n.d.). What is Zigbee technology. Retrieved from <https://www.electronics-notes.com/articles/connectivity/zigbee/what-is-zigbee-technology-tutorial.php>
- Executive Services Directorate. (n.d.). DoD forms management program. Retrieved January 30, 2019, from https://www.esd.whs.mil/Directives/forms/dd1000_1499/
- Ferro, E., & Potorti, F. (2005, February). *IEEE Wireless Communications*, 12(1), 12–26
- Friedl, K. E., Buller, M. J., Tharion, W. J., Potter, A. W., Manglapus, G. L., & Hoyt, R. W. (2016). *Real time physiological status monitoring (RT-PSM): Accomplishments, requirements, and research roadmap* (Technical Note No. TN16-2). Natick, MA: U.S. Army Research Institute of Environmental Medicine.
- Friedl, K. E. (2018). Military applications of soldier physiological monitoring. *Journal of Science and Medicine in Sport* 21(11), 1147–1153. Retrieved from <https://www.sciencedirect.com/science/article/pii/S144024401830255X?via%3Dihub>
- goTenna. (n.d.) goTenna. Retrieved from <https://www.gotenna.com/>
- GSMARENA. (n.d.a). Samsung Galaxy S5. Retrieved from https://www.gsmarena.com/samsung_galaxy_s5-6033.php
- GSMARENA. (n.d.b). Samsung Galaxy S5. Retrieved from https://www.gsmarena.com/samsung_galaxy_s9+-8967.php
- Hirschberg, D. L., Samuels, A. C., Rosenzweig, C. N., Lux, M. W., Emanuel, P. A., Miklos, A. E., Betts, K. D., Kilianski, A., & Brooks, J. R. (2016). Retrieved from Defense Technical Information Center website: <https://apps.dtic.mil/docs/citations/AD1009537>
- IEEE 802. (2019, January 19). IEEE 802 LAN/MAN standards committee. Retrieved from <http://www.ieee802.org/>
- Kotwal, R. S., Butler, F. K., Montgomery, H. R., Brunstetter, T. J., Diaz, G. Y., Kirkpatrick, J. W., Summers, N. L., Shackelford, S. A., Holcomb, J. B., & Bailey, J. A. (2013). The tactical combat casualty care casualty card TCCC guidelines proposed change 13–01. *Journal of Special Operations Medicine*, 13(2), 82–87.
- Lakkundi, V. (2006). Ultra wideband communications: History, evolution and emergence. *Acta Polytechnica*, 46(4), 18–20.
- Masimo. (2010). *Emma capnograph: Product information*. Irvine, CA: Author. Retrieved from http://www.masimo.com/siteassets/us/documents/pdf/plm-10642a_product_information_emma_capnograph_us.pdf

- Masimo. (2017). *MightySat fingertip pulse oximeter: Operator's manual*. Irvine, CA: Author. Retrieved from <http://masimopersonalhealth.com/manuals/>
- Miles, E. A. (2012). *The casualty network system capstone project* (Master's thesis). Retrieved from <https://calhoun.nps.edu/handle/10945/27870>
- Montgomery, R. R., & Anderson, Y. L. (2016). *Battlefield Medical Network: Biosensors in a tactical environment* (Master's thesis). Retrieved from <https://calhoun.nps.edu/handle/10945/48568>
- Persistent Systems. (n.d.). Wave relay. Retrieved from <http://www.persistentsystems.com/persistent-systems-technology-intro/>
- Persistent Systems. (2016). *Man portable unit gen4*. New York, NY: Author. Retrieved from http://www.persistentsystems.com/pdf/MPU4_SpecSheet.pdf
- Persistent Systems. (2017). *MPU5 specification sheet*. New York, NY: Author. Retrieved from http://www.persistentsystems.com/site/wp-content/themes/persistentsystems/pdf/mpu5/mpu5_spec_sheet.pdf
- Polar. (n.d.a). Compare heart rate sensors. Retrieved from https://www.polar.com/us-en/products/accessories/h10_heart_rate_sensor
- Polar. (n.d.b). *Polar H10 user manual*. Bethpage, NY: Author. Retrieved from https://support.polar.com/e_manuals/H10_HR_sensor/Polar_H10_user_manual_English/manual.pdf
- Polar. (n.d.c). What is the Bluetooth transmission range of Polar H10 HR sensor? Retrieved February, 12, 2019, https://support.polar.com/us-en/support/what-is-the-bluetooth-transmission-range-of-polar-h10-hr-sensor?product_id=89506&category=settings
- Polar. (n.d.d). Polar. Retrieved February 12, 2019, https://support.polar.com/e_manuals/Regulatory_information/ENOTE_RF_H10.pdf
- Pothuganti, K., & Chitneni, A. (2014). A comparative study of wireless protocols: Bluetooth, UWB, Zigbee, and Wi-Fi. *Advance in Electronic and Electric Engineering*, 4(6), 655–662.
- Raspberry Pi. (Producer). (n.d.). *About us* [YouTube]. Retrieved from <https://www.raspberrypi.org/about/>
- Research and Technology Organisation. (2010). *Real-time and physiological and psychological status monitoring* (Report No. TR-HFM-132). Retrieved from https://www.sto.nato.int/publications/Pages/Technical_Reports_List.aspx

- Review of the FY2019 budget request for the defense health program*, U.S. Senate Committee on Appropriations (2018) (testimony of Vice Admiral C. Forrest Faison III, Surgeon General of the Navy).
- Saber com Logica. (n.d.) The link layer. Retrieved from <http://sabercomlogica.com/en/ebook/the-link-layer-mac-address-and-arp/>
- SolarWinds. (2019). *Bandwidth gauges*. Austin, TX: Author. Retrieved from [https://support.solarwinds.com/Success_Center/Engineers_ToolSet_\(ETS\)/ETS_Documentation/Engineers_Toolset_Administrator_Guide/050_Tools_References/020_Bandwidth_Gauges](https://support.solarwinds.com/Success_Center/Engineers_ToolSet_(ETS)/ETS_Documentation/Engineers_Toolset_Administrator_Guide/050_Tools_References/020_Bandwidth_Gauges)
- Stegner, B. (2017, December 12). What is an APK file and what does it do? Retrieved from <https://www.makeuseof.com/tag/what-is-apk-file/>
- Subramanian, M. (2010). *Network management*. Chennai, India: Pearson.
- Tanenbaum, A. S., Wetherall, D. J. (2011). *Computer networks* (5th ed.). Boston, MA: Prentice Hall.
- Tharion, W. J., Buller, M. J., Karis, A. J., & Hoyt, R. W. (2010). Development of a remote medical monitoring system to meet soldier needs. In Marek, T., Karwowski, & Rice, V. (Eds.), *Advances in understanding human performance: neuroergonomics, human factors design, and special populations* (pp. 491–500). Boca Raton, FL: CRC Press.
- United States Marine Corps. (2016). *Marine Corps operating concept*. Washington, DC: Author.
- Wang, J., Xie, B., Agrawal, D. P. (2009). Journey from mobile ad hoc networks to wireless mesh networks. In Misra, S., Misra, S. C., & Woungang, I. (Eds.), *Guide to wireless mesh networks* (1-30). London, United Kingdom: Springer-Verlag London.
- Zephyr. (2017). *Zephyr biomodule: Instructions for use*. Annapolis, MD: Author. Retrieved from <https://www.medtronic.com/content/dam/covidien/library/us/en/product/pulse-oximetry/zephyr-biomodule-instructions-manual-english.pdf>

INITIAL DISTRIBUTION LIST

1. Defense Technical Information Center
Ft. Belvoir, Virginia
2. Dudley Knox Library
Naval Postgraduate School
Monterey, California