



**NAVAL
POSTGRADUATE
SCHOOL**

MONTEREY, CALIFORNIA

THESIS

**UNINTENDED CONSEQUENCES: UNDERSTANDING THE
EFFECTS OF CHANGING INFANTRY BATTALION
FORCE STRUCTURE ON FORCE GENERATION
WITH NETWORK OPTIMIZATION**

by

Christopher J. Teska

June 2019

Thesis Advisor:
Co-Advisor:
Second Reader:

Ruriko Yoshida
Carlos F. Borges
Matthew Norton

Approved for public release. Distribution is unlimited.

THIS PAGE INTENTIONALLY LEFT BLANK

REPORT DOCUMENTATION PAGE			<i>Form Approved OMB No. 0704-0188</i>
Public reporting burden for this collection of information is estimated to average 1 hour per response, including the time for reviewing instruction, searching existing data sources, gathering and maintaining the data needed, and completing and reviewing the collection of information. Send comments regarding this burden estimate or any other aspect of this collection of information, including suggestions for reducing this burden, to Washington headquarters Services, Directorate for Information Operations and Reports, 1215 Jefferson Davis Highway, Suite 1204, Arlington, VA 22202-4302, and to the Office of Management and Budget, Paperwork Reduction Project (0704-0188) Washington, DC 20503.			
1. AGENCY USE ONLY (Leave blank)	2. REPORT DATE June 2019	3. REPORT TYPE AND DATES COVERED Master's thesis	
4. TITLE AND SUBTITLE UNINTENDED CONSEQUENCES: UNDERSTANDING THE EFFECTS OF CHANGING INFANTRY BATTALION FORCE STRUCTURE ON FORCE GENERATION WITH NETWORK OPTIMIZATION		5. FUNDING NUMBERS	
6. AUTHOR(S) Christopher J. Teska			
7. PERFORMING ORGANIZATION NAME(S) AND ADDRESS(ES) Naval Postgraduate School Monterey, CA 93943-5000		8. PERFORMING ORGANIZATION REPORT NUMBER	
9. SPONSORING / MONITORING AGENCY NAME(S) AND ADDRESS(ES) N/A		10. SPONSORING / MONITORING AGENCY REPORT NUMBER	
11. SUPPLEMENTARY NOTES The views expressed in this thesis are those of the author and do not reflect the official policy or position of the Department of Defense or the U.S. Government.			
12a. DISTRIBUTION / AVAILABILITY STATEMENT Approved for public release. Distribution is unlimited.		12b. DISTRIBUTION CODE A	
13. ABSTRACT (maximum 200 words) This research seeks to understand the balance between Total Force Structure changes and the Force Generation Process. The Marine Corps must adapt its infantry battalion force structure to maintain an advantage in future conflicts. These changes affect not only the number of Marines but also the mix of ranks and specialties required to man deploying units. Traditionally, planners utilized mixed-integer linear programs to forecast the manpower mix to meet structural requirements. The network flow approach used in this research provides a better and faster tool to understand how structural changes will affect the ability to man the service as a whole. The model utilizes manpower projections, Tables of Organization, historical deployment schedules, and mathematical optimization to produce solutions that maximize infantry battalion readiness while minimizing the effect on the supporting establishment. The flexible nature of the model allows decision makers to evaluate current and proposed policy in manpower management with respect to its impact on deploying unit readiness. The increases in efficiency allow planners to quickly estimate the readiness consequences of new policy. Sensitivity analysis on all constraints delivers insight into possible adjustments to recruiting and retention goals, unit staffing goals, and deployment rhythm. The results of this research are both a high-level evaluation of current policy and a set of practical tools to assess proposed changes.			
14. SUBJECT TERMS optimization, Marine Corps, manpower, force generation, infantry, manning, network, assignment, USMC, deployment, dwell, data warehouse, Table of Organization, staffing, total force structure, manning, network optimization, network flow		15. NUMBER OF PAGES 79	
		16. PRICE CODE	
17. SECURITY CLASSIFICATION OF REPORT Unclassified	18. SECURITY CLASSIFICATION OF THIS PAGE Unclassified	19. SECURITY CLASSIFICATION OF ABSTRACT Unclassified	20. LIMITATION OF ABSTRACT UU

THIS PAGE INTENTIONALLY LEFT BLANK

Approved for public release. Distribution is unlimited.

**UNINTENDED CONSEQUENCES: UNDERSTANDING THE EFFECTS OF
CHANGING INFANTRY BATTALION FORCE STRUCTURE ON
FORCE GENERATION WITH NETWORK OPTIMIZATION**

Christopher J. Teska
Captain, United States Marine Corps
BS, U.S. Naval Academy, 2013

Submitted in partial fulfillment of the
requirements for the degrees of

MASTER OF SCIENCE IN OPERATIONS RESEARCH

and

MASTER OF SCIENCE IN APPLIED MATHEMATICS

from the

**NAVAL POSTGRADUATE SCHOOL
June 2019**

Approved by: Ruriko Yoshida
Advisor

Carlos F. Borges
Co-Advisor

Matthew Norton
Second Reader

W. Matthew Carlyle
Chair, Department of Operations Research

Wei Kang
Chair, Department of Applied Mathematics

THIS PAGE INTENTIONALLY LEFT BLANK

ABSTRACT

This research seeks to understand the balance between Total Force Structure changes and the Force Generation Process. The Marine Corps must adapt its infantry battalion force structure to maintain an advantage in future conflicts. These changes affect not only the number of Marines but also the mix of ranks and specialties required to man deploying units. Traditionally, planners utilized mixed-integer linear programs to forecast the manpower mix to meet structural requirements. The network flow approach used in this research provides a better and faster tool to understand how structural changes will affect the ability to man the service as a whole. The model utilizes manpower projections, Tables of Organization, historical deployment schedules, and mathematical optimization to produce solutions that maximize infantry battalion readiness while minimizing the effect on the supporting establishment. The flexible nature of the model allows decision makers to evaluate current and proposed policy in manpower management with respect to its impact on deploying unit readiness. The increases in efficiency allow planners to quickly estimate the readiness consequences of new policy. Sensitivity analysis on all constraints delivers insight into possible adjustments to recruiting and retention goals, unit staffing goals, and deployment rhythm. The results of this research are both a high-level evaluation of current policy and a set of practical tools to assess proposed changes.

THIS PAGE INTENTIONALLY LEFT BLANK

Table of Contents

1	Introduction	1
1.1	The Marine Corps	1
1.2	Structure of the Marine Corps	2
1.3	Marine Force Structure and Assignments	13
1.4	Research Questions	18
2	Previous Work	21
2.1	Past Manpower Research	21
2.2	Network Flow Models	22
3	Data	25
3.1	Historical Data	25
3.2	Current Data	26
4	Methodology and Formulation	29
4.1	Basic Model Structure	29
4.2	Indices	31
4.3	Sets	32
4.4	Parameters and Data	33
4.5	Variables	34
4.6	Constraints	34
4.7	Objective Function	39
5	Results	41
5.1	Experiments and Cases	41
5.2	Results	42
5.3	Computational Results	51
5.4	Future Work	52
5.5	Conclusion and Recommendations	52

List of References	55
Initial Distribution List	57

List of Figures

Figure 1.1	Structure of Marine Forces Command Adapted from DC CD and I (2015).	5
Figure 1.2	Organization of the Marine Forces Pacific Adapted from DC CD and I (2015)	6
Figure 1.3	Organization of a Marine Expeditionary Force Adapted from DC CD and I (2015).	6
Figure 1.4	Organization of the 1st Marine Division Adapted from DC CD and I (2015).	7
Figure 1.5	Organization of the 2nd Marine Division Adapted from DC CD and I (2015).	7
Figure 1.6	Organization of the 3rd Marine Division Adapted from DC CD and I (2015).	8
Figure 1.7	Organization of a Typical Infantry Battalion DC CD and I (2015).	11
Figure 4.1	Basic Structure of Total Force Network Flow Model.	30
Figure 5.1	Total Shortfall.	42
Figure 5.2	Total Excess.	42
Figure 5.3	The Structural Excess and Shortfall for Experiment 1. The Total for Cases I and III and Cases II and IV Are Virtually the Same.	42
Figure 5.4	Shortfall Within Fleet Marine Force (FMF) Units Stabilized for Deployment.	44
Figure 5.5	Monthly Shortfall by Military Occupational Specialties (MOS) for each Case.	44
Figure 5.6	Monthly Shortfall by Rank for each Case.	45
Figure 5.7	Monthly Excess by Rank for each Case.	46

Figure 5.8	Monthly Excess by MOS for each Case.	46
Figure 5.9	Total Shortfall.	48
Figure 5.10	Total Excess.	48
Figure 5.11	The Structural Excess and Shortfall for Experiment 2. There is a Significant Reduction in Both Shortfall and Excess Between Experiments.	48
Figure 5.12	Shortfall in Stabilized Units for each Case.	49
Figure 5.13	Monthly Shortfall by Sank for each Case.	49
Figure 5.14	Monthly Excess by Rank for each Case.	50
Figure 5.15	Monthly Excess by MOS for each Case.	50
Figure 5.16	Shortfalls Filled by Other Rank-MOS Marines by Month.	50

List of Tables

Table 1.1	Battalion and Regimental Parent Command Structure.	10
Table 1.2	Infantry Military Occupational Specialties Adapted from Commanding General (CG), Training and Education Command (TECOM) (2016).	10
Table 5.1	Total Shortfall by Component for 36-month Experiment.	43
Table 5.2	Total Excess by Component for 36-month Experiment.	45
Table 5.3	Total Shortfall by Component for 36-month Experiment with “One-up, One-down.”	48
Table 5.4	Where Excess Marines Provide Support for Case III.	51

THIS PAGE INTENTIONALLY LEFT BLANK

List of Acronyms and Abbreviations

ASR	Authorized Strength Report
BIC	Billet Identifier Codes
CAB	Combat Assault Battalion
CCDRs	Combatant Commanders
CD/I	Combat Development and Integration
CENTCOM	Central Command
CG	Commanding General
CMC	Commandant of the Marine Corps
DC	Deputy Commandant
DoD	Department of Defense
EAS	End of Active Service
ELS	Entry Level School
EUCOM	European Command
FAST	Fleet Antiterrorism Security Team
FGP	Force Generation Process
FMF	Fleet Marine Force
FS	Force Synchronization
GFM	Global Force Management
H/S	Headquarters and Service

HQMC	Headquarters, Marine Corps
ISR	Intelligence, Reconnaissance, and Surveillance
LAR	Light Armored Reconnaissance
LOGCOM	Logistics Command
LP	Linear Programs
M/RA	Manpower and Reserve Affairs
MAGTF	Marine Air-Ground Task Force
MARDIV	Marine Division
MARFORCENT	Marine Forces Central Command
MARFORCOM	Marine Forces Command
MARFORCYBER	Marine Forces Cyber Command
MARFOREUR	Marine Forces European Command
MARFORNORTH	Marine Forces Northern Command
MARFORPAC	Marine Forces Pacific
MARFORRES	Marine Forces Reserve
MARFORSOC	Marine Forces Special Operations Command
MARFORSOUTH	Marine Forces Southern Command
MARFORSTRAT	Marine Forces Strategic Command
MCC	Monitor Command Codes
MCCDC	Marine Corps Combat Development Command
MCO	Marine Corps Order
MCRC	Marine Corps Recruiting Command

MCRP	Marine Corps Reference Publication
MCSFB	Marine Corps Security Force Battalions
MCSFR	Marine Corps Security Force Regiment
MEB	Marine Expeditionary Brigade
MEF	Marine Expeditionary Force
METs	Mission Essential Tasks
MEU	Marine Expeditionary Units
MILP	Mixed Integer Linear Programs
MOC	Marine Corps Operating Concept
MOS	Military Occupational Specialties
MPL	Manpower Precedence Levels
NPS	Naval Postgraduate School
OpFor	Operating Forces
PACOM	Pacific Command
PCA	Permanent Change of Assignment
PCS	Permanent Change of Station
PP/O	Plans, Policies, and Operations
SE	Supporting Establishment
SECDEF	Secretary of Defense
SNCO	Staff Noncommissioned Officers
SPMAGTF	Special Purpose Marine Air-Ground Task Force
SUAS	Small Unmanned Aerial Surveillance

T2P2	Transients, Trainees, Patients, and Prisoners
TECOM	Training and Education Command
TFSP	Total Force Structure Process
TFSP	Total Force Structure Process
TO/E	Table of Organization and Equipment
TOS	Time on Station
UDP	Unit Deployment Program
UIC	Unit Identifier Codes
USG	United States Government
USMC	U.S. Marine Corps
USN	U.S. Navy

Executive Summary

This research serves two purposes. The first purpose is to build a model capable of assessing the effects of future force structure changes on the Marine Corps' infantry population. Second, this model was applied to the currently proposed infantry force structure change from a 13-man rifle squad to a 15-man squad.

The model itself serves to synchronize the efforts of multiple components within Headquarters, Marine Corps (HQMC). The current process splits the force synchronization, total force structure, and manning among Marine Forces Command (MARFORCOM), Combat Development and Integration (CD/I), and Manpower and Reserve Affairs (M/RA) respectively. Each Deputy Commandant (DC) develops policy independently and works to manually synchronize upon completion.

The model produced in this research automates the synchronization with improved results. The modular structure of the model allows planners to quickly manipulate policy inputs for Entry Level School (ELS) production, promotion rates, End of Active Service (EAS) rates, force structure changes, and deployment scheduling. This allows each DC to isolate its own inputs to the Force Generation Process (FGP) and assess possible courses-of-action in the context of other policies.

The outputs of the model provide many insights. First, they show the immediate manpower shortfalls across the population when implementing a new change as well as the time required to balance the current population to the new structure. Second, they show both the shortfalls and excesses within each rank and MOS across the force. When considered together, these data points show where the service can adjust its population distribution in order to best match its desired structure. Finally, the outputs show where the shortfalls occur in the model. This output is particularly useful as it shows how manipulating the structure of the Operating Forces (OpFor) affects the ability Supporting Establishment (SE) and at what threshold those changes begin to cause shortfalls in stabilized and deployed units.

The model itself considers 3.7 million variables and more than 900,000 constraints. Using Pyomo on a Linux machine with 112 Intel 32-bit processors, each experiment and case were conducted simultaneously with model build times of approximately 80 minutes and

solve times to optimality of approximately 10 minutes. The computational results from this network flow model are a significant improvement over previous work done on the subject using mixed integer linear programming. The best prior attempt used a similarly configured machine and took two weeks to find a solution within 27% of optimality. The significant improvements in performance facilitated by the network flow approach will allow both quicker and more accurate analysis of the impact of future force structure changes on force generation.

When considering the impact of the 15-man rifle squad, the current distribution of Marines by rank and MOS cannot support the proposed change from a 13-man rifle squad. The current structure is barely supportable, and the proposed change results in an 82% increase in shortfall across the population with less than a 3% increase in structure. More importantly, when considering a regimental-sized contingency operation, there is a 34% greater shortfall in stabilized and deployed units compared to the current structure under the same deployment conditions. The proposed change is intended to increase the combat effectiveness of the Marine Corps; however, without adjusting other manpower policies this change will reduce combat effectiveness by increasing manpower shortfalls.

The greatest cause of shortfalls is a top-heavy force. Throughout all situations and MOSs considered, there were excesses of senior Marines with shortfalls of junior Marines. Although the practice of “one-up, one-down” manning mitigates this policy-driven issue, the disparity between the actual population and the population required by the proposed force structure is concerning. Additionally, the addition of two “0311”s per rifle squad greatly increased the shortfalls within this population while the “0331,” “0341,” and “0352” MOSs had consistent excesses.

In order to adapt the force to the proposed structure, the Marine Corps should make two changes. First, it should permanently slow the promotion rate from “E3” to “E4” in order to offset the match the increased structure at the junior ranks. There are significant shortfalls in the “E3” population driven primarily by promotion into the already full “E4” population. This leads to both cost and structural inefficiencies in the form of pay increases for Marines to perform the same role. Second, the ELSs should reduce the production of the “0331,” “0341,” and “0352” MOSs in favor of increases in “0311” production. Current proposals suggest the increased “0311” shortfall can be made up by eliminating the “0351” MOS, but

that will not provide enough population by itself.

THIS PAGE INTENTIONALLY LEFT BLANK

CHAPTER 1: Introduction

“The Marine Corps is currently not organized, trained, and equipped to meet the demands of a future operating environment characterized by complex terrain, technology proliferation, information warfare, the need to shield and exploit signatures, and an increasingly non-permissive maritime domain.”

—Statement of the Central Problem
Marine Corps Operating Concept, 2016

1.1 The Marine Corps

The U.S. Marine Corps (USMC) exists in order to fight the demanding battles for control of the world’s littoral regions. In fact, Title 10 of the U.S. Code mandates the Marine Corps be “comprised of not less than three combat divisions and three combat air wings... organized, trained, and equipped to provide fleet marine forces of combined arms, together with supporting air components, for service with the fleet in the seizure or defense of advanced naval bases and for the conduct of such land operations as may be essential to the prosecution of a naval campaign” (United States Congress 2017); however, Congress does not define what constitutes these combat divisions and air wings. Instead, Title 10 asserts the relevance of the Marine Corps and defines its core mission while preserving the organization’s flexibility to organize itself. With an evolving and uncertain threat landscape, the Marine Corps must adapt the force structure of its “three combat divisions” to these dynamic threats. At the same time, the service cannot afford, in either monetary resources or human capital, to make mistakes in these force structure changes. This research provides a solution to this challenge by modelling the assignment of infantry Marines to both the Fleet Marine Force (FMF) and the Supporting Establishment (SE). The model itself is fast, realistic, and easy to manipulate, allowing decision makers to assess the resilience of many contingency scenarios against current and proposed manpower policies.

1.1.1 Marine Corps Operating Concept

The Marine Corps Operating Concept (MOC) is the Commandant of the Marine Corps (CMC)'s description of how the Marine Corps will approach the current threat environment with respect to its Title 10 mandate. Specifically, the CMC emphasizes the challenges imposed by the U.S.'s current transition from extended ground wars against technologically inferior opponents to littoral, cross-domain conflict against near peer adversaries. He raises many challenges which the USMC must solve in preparation for these conflicts; however, he clearly designates the central problem: "the Marine Corps is currently not organized, trained, and equipped to meet the demands of a future operating environment characterized by complex terrain, technology proliferation, information warfare, the need to shield and exploit signatures, and an increasingly non-permissive maritime domain" (United States Marine Corps 2016).

The MOC continues to describe specific concerns for the adaptability of infantry units to the coming technological environment. The concept calls for the reorganization of historic infantry formations in order to dominate not only the land but also the sea, air, cyber, and space domains.

This is clearly an enormous task. Leaders throughout the Marine Corps are experimenting with changes to squad sizes, the use of combat engineers, the incorporation of Small Unmanned Aerial Surveillance (SUAS) operators, and more, all of which affect the makeup of the infantry battalion and the structure of the Corps' infantry community in general. Failure to assess and understand the side-effects of changing the makeup of the FMF infantry units on the SE, including recruiting, embassy security, and Marine Corps Security Force Regiment (MCSFR), could actually degrade the lethality of the USMC. "The profession of arms is unforgiving; mistakes are paid for in blood and incompetence can lead to catastrophic defeat. When we fight, we must win. There is no alternative" (United States Marine Corps 2016). Change to the Marine Corps infantry is clearly necessary, though we must understand the totality of that change in order to ensure that it is successful.

1.2 Structure of the Marine Corps

Marine Corps Reference Publication (MCRP) 5-12D Organization of the United States Marine Corps serves as the authoritative document outlining the current structure of the

USMC (DC CD and I 2015). The service consists of “two parallel chains of command- service and operational” (DC CD and I 2015). The operational chain of command contains all units currently assigned to geographic or functional Combatant Commands. This chain of command reports directly to the President of the United States for current and future operations.

The service chain of command is tasked to man, train, and equip the Marine Corps. Important for this research, all units- whether operational or support- fall under this chain of command for the purposes of assignment. MCRP 5-12D divides the Marine Corps into three categories: “Headquarters, Marine Corps (HQMC) and supporting activities, the Marine Corps Operating Forces (OpFor), and the supporting establishment” (DC CD and I 2015).

1.2.1 HQMC and Supporting Activities

HQMC is made up of the CMC, other senior leaders, staffs, and Marines and is responsible for “recruiting, organizing, supplying, equipping, training, servicing, mobilizing, demobilizing, administering, and maintaining of the Marine Corps” (DC CD and I 2015). HQMC is comprised primarily of experienced Marine officers and enlisted capable of researching, designing, and disseminating plans and policy for the rest of the Marine Corps to execute.

The Supporting Activities are responsible with the execution of plans and policy set out by HQMC. Examples include Marine Corps Combat Development Command (MCCDC) which is responsible for developing requirements and capabilities for Marine Corps units and technologies, Logistics Command (LOGCOM) which is responsible for the maintenance of Marine Corps equipment, and Marine Corps Recruiting Command (MCRC) which is responsible for both recruiting and initial training of new Marines. As this research focuses on the junior enlisted ranks, the majority of Marines in these units will be within the Supporting Activities units (DC CD and I 2015).

Supporting Establishment

MCRP 5-12D describes the SE as the “personnel, bases, and activities that support the Marine Corps operating forces.” The 30,000 Marines in the SE work primarily to ensure the security, maintenance, and administration of Marine Corps installations and bases.

1.2.2 Operating Forces

Marine Corps OpFor are split into three major commands: Marine Forces Pacific (MARFORPAC), Marine Forces Command (MARFORCOM), and Marine Forces Reserve (MARFORRES). MARFORPAC and MARFORCOM each contain the active-duty Marine Air-Ground Task Force (MAGTF)s which— once manned, trained, and equipped within the service chain of command—are deployed to support the Combatant Commanders in support of missions in the operational chain of command.

Marine Forces Reserve

MARFORRES maintains the reserve component force prepared to reinforce active units when required (DC CD and I 2015). It is comprised of three main elements: Ready Reserve, Standby Reserve, and Retired Reserve. The Standby and Retired Reserve consist of Marines who have completed or are unable to complete their military obligation. The Ready Reserve, MARFORRES's largest element, consists of "units and individual members who are liable for immediate active duty during war or national emergency" (DC CD and I 2015). These units are primarily made up of Marines who have completed time on active duty and elected to remain available for national emergencies as well as Marines who enlisted directly into the Ready Reserve; however, each unit also contains a small cohort of active duty officers and enlisted Marines responsible for equipment maintenance, training, logistical planning, and administration of the unit while the rest of the unit is away. For the purposes of this research, only this small active cohort is of interest.

Marine Forces Command

MARFORCOM is headquartered in Norfolk, Virginia. Figure 1.1 outlines the MARFORCOM structure. It has two primary functions, to coordinate Force Generation with Joint Staff and to serve as the command element for FMF Atlantic (DC CD and I 2015). It is comprised of a Command Element, Headquarters and Service (H/S) Battalion, the Marine Corps Security Cooperation Group, Chemical Biological Incident Force, II Marine Expeditionary Force (MEF), and the MCSFR. The first function, coordination with the Joint Staff, is conducted primarily in the Command Element, and the second is the responsibility of II MEF and MCSFR.

The MCSFR provides "expeditionary antiterrorism and security forces in support of Com-

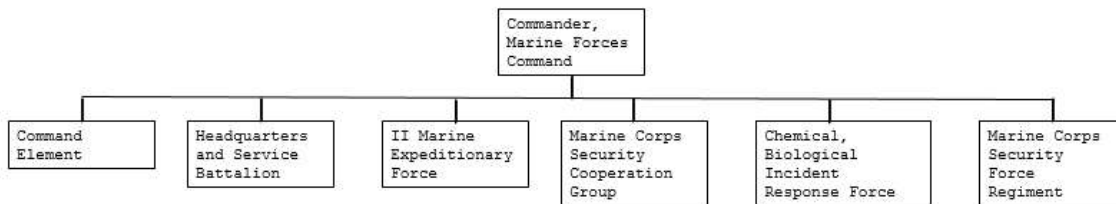

Figure 1.1. Structure of Marine Forces Command Adapted from DC CD and I (2015).

batant Commands and naval commanders in order to conduct expeditionary security operations and provide security for strategic weapons and vital national assets” (DC CD and I 2015). It is comprised of two Marine Corps Security Force Battalions (MCSFB), one on each coast of the United States, and three Fleet Antiterrorism Security Team (FAST) companies, one each focused on Europe, the Middle East, and the Pacific. The MCSFBs are responsible for securing strategic assets in Bangor, Washington, and Kings Bay, Georgia. The FAST companies exist “to provide expeditionary anti-terrorism and security operations in order to protect vital national and naval assets” (DC CD and I 2015). Both have similar assignment procedures. The leadership is made up of officers, Staff Noncommissioned Officers (SNCO), and sergeant squad leaders on three-year orders. The remainder is made up of 0311 riflemen arriving directly from Entry Level School (ELS) on two-year orders; following completion these Marines will transfer directly to an FMF unit.

Marine Forces Pacific

MARFORPAC differs from MARFORCOM in both structure and function. Instead of coordinating with the Joint Staff, MARFORPAC serves as the geographic component commander for the United States’ Pacific Command (PACOM), thus serves as both the head of both the service and operational chains of command. As shown in Figure 1.2, it contains a Command Element, H/S battalion, I MEF, and III MEF. It is headquartered at Camp Smith, Hawaii in order to support PACOM; however, the majority of Marines are stationed in either southern California with I MEF or Okinawa, Japan III MEF (DC CD and I 2015).

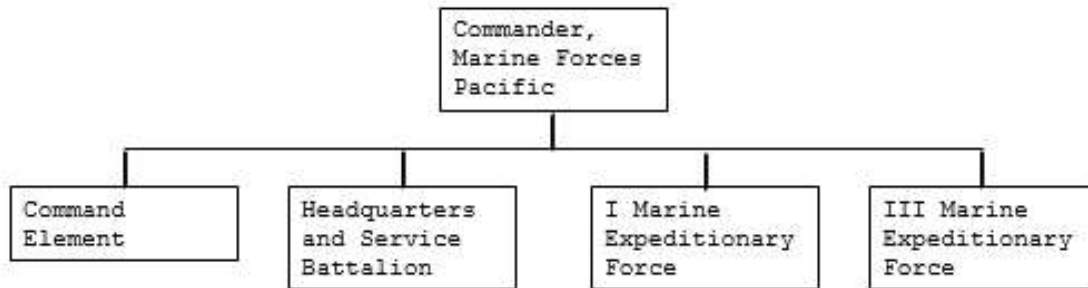

Figure 1.2. Organization of the Marine Forces Pacific Adapted from DC CD and I (2015)

Marine Expeditionary Forces

Between MARFORCOM and MARFORPAC the Marine Corps has three MEFs which serve as its primary warfighting organizations. Each MEF is built around a Command Element, Marine Division, Marine Logistics Group, Marine Air Wing, a Marine Expeditionary Brigade (MEB), and several independent battalions, Figure 1.3 illustrates. I and II MEFs each have three Marine Expeditionary Units (MEU) while III MEF has only the 31st MEU. Enlisted infantry Marines will be assigned to all of these elements, though the vast majority

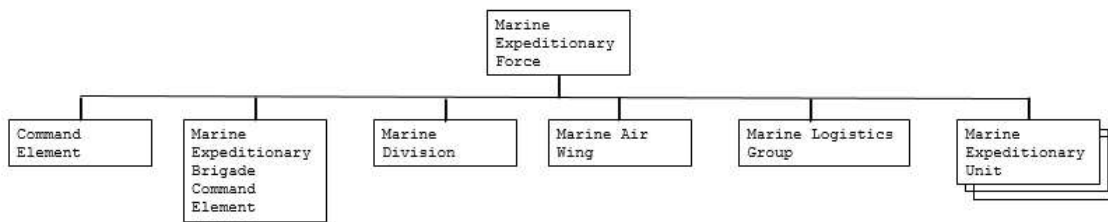

Figure 1.3. Organization of a Marine Expeditionary Force Adapted from DC CD and I (2015).

of this research’s population of interest will be in the Marine Divisions. These divisions contain the regiments and battalions to which Marines are assigned and from which they deploy. These three also form the backbone Title 10 mandated structure for the Marine Corps (United States Congress 2017). However, as Title 10 does not dictate what constitutes a Marine Division, each of the three has a significantly different structure.

1st Marine Division (MARDIV), in I MEF, is the largest of the three. Figure 1.4 shows its organization. It consists a H/S Battalion, a Reconnaissance Battalion, a Combat Engineer Battalion, a Tank Battalion, an Assault Amphibian Battalion, an Artillery Regiment, and two Light Armored Reconnaissance (LAR) Battalions. The core of 1st MARDIV is its three Infantry Regiments, each with four Infantry Battalions, giving the division 12 deployable Infantry Battalions. 1st MARDIV is headquartered in Camp Pendleton, California, with some units stationed in Twentynine Palms, California.

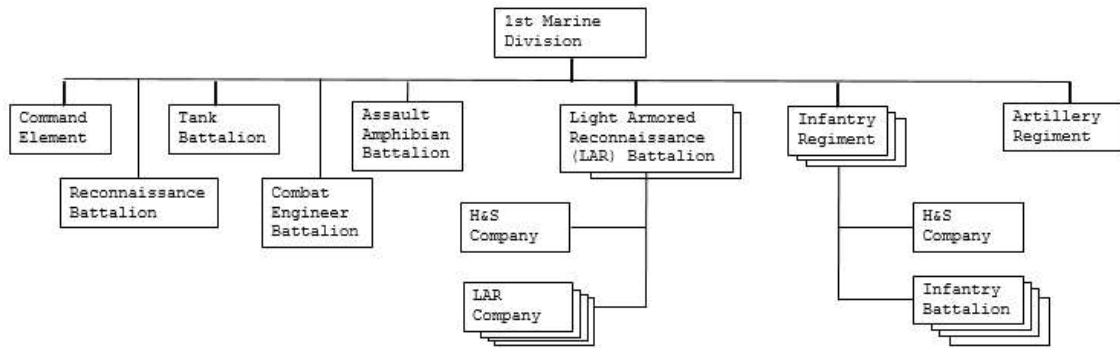

Figure 1.4. Organization of the 1st Marine Division Adapted from DC CD and I (2015).

2nd MARDIV, in II MEF, is similar in size and structure to 1st MARDIV. Figure 1.5 shows the organization of the division. The largest difference is that 2nd MARDIV has only one

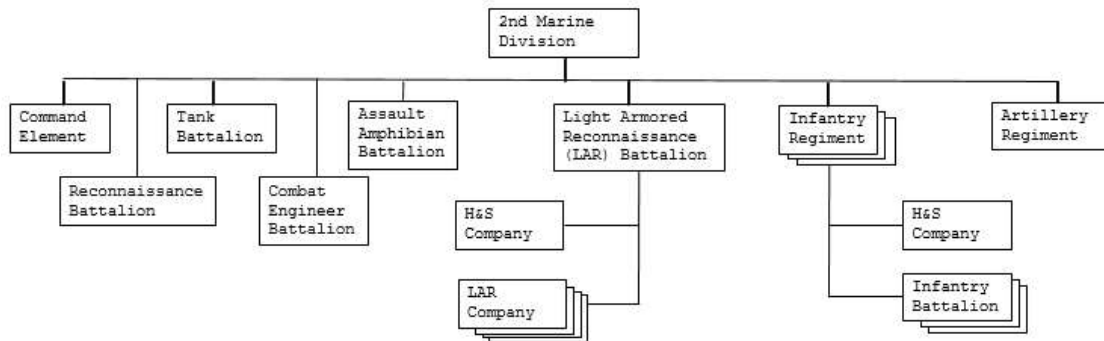
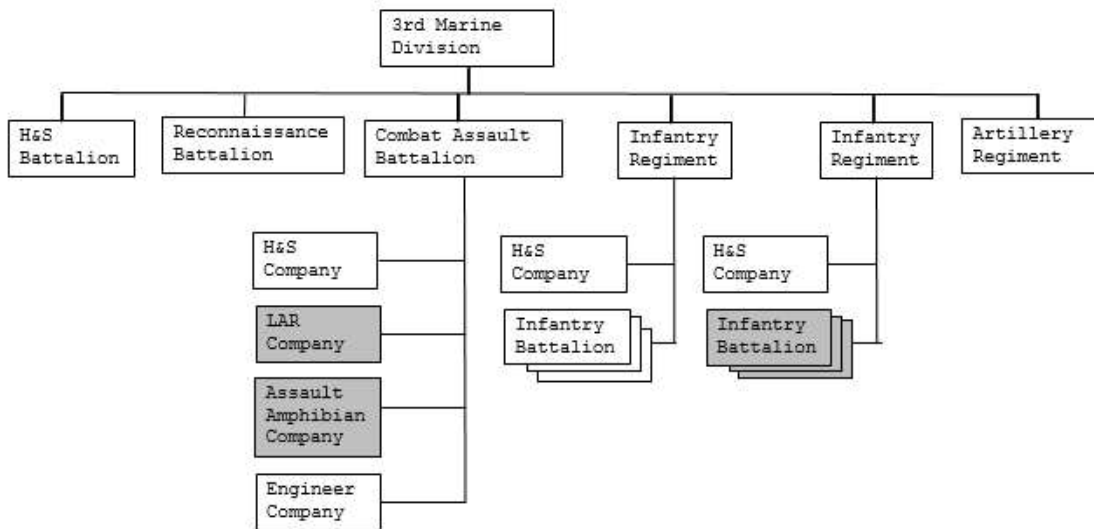

Figure 1.5. Organization of the 2nd Marine Division Adapted from DC CD and I (2015).

LAR Battalion and each of its three Infantry Regiments has only three Infantry Battalions,

giving the division 9 deployable Infantry Battalions. 2nd MARDIV is headquartered in Camp Lejeune, North Carolina.

3rd MARDIV, in III MEF, has the most unique structure. The division is significantly smaller as it is forward deployed to Okinawa, Japan. Thus, it has fewer armored vehicles and many of its units are rotationally deployed from either 1st or 2nd MARDIV. Figure 1.6 shows the division's structure. It contains only an H/S Battalion, Reconnaissance Battalion, Combat Assault Battalion (CAB), two Infantry Regiments, and an Artillery Regiment. The CAB contains a permanent headquarters and engineer company, while the LAR Company and Assault Amphibian Company are deployed from the other divisions. 3rd Marine Regiment, stationed in Hawaii, is under 3rd MARDIV for both its service and operational chain of command. 4th Marine Regiment, in Okinawa, Japan, has only a permanent Regimental staff; its infantry battalions are deployed rotationally from either the 1st or 2nd MARDIVs. Thus 3rd MARDIV has only three deployable Infantry Battalions.



Gray boxes represent deployed units which are not within the service chain of command.

Figure 1.6. Organization of the 3rd Marine Division Adapted from DC CD and I (2015).

Other Component Commands

In addition to MARFORCOM, MARFORPAC, and MARFORRES, the Marine Corps has other Component Commands within the Operating Forces which report directly to geographic and functional Combatant Commanders. With the exception of the functional Component Commands—Marine Forces Special Operations Command (MARFORSOC), Marine Forces Cyber Command (MARFORCYBER), and Marine Forces Strategic Command (MARFORSTRAT)—these commands are comprised of a permanent staff to conduct mission planning and coordination from deployed Marine units to their respective Combatant Commanders. Thus, for the purposes of this research, we will focus only on the assignment of enlisted infantry Marines to the supporting staffs of these commands.

1.2.3 The Marine Corps Infantry

“The primary mission of the infantry battalion is to locate, close with, and destroy the enemy by fire and maneuver or to repel his assault by fire and close combat.”

—MCRP 5-12D, Organization of the Marine Corps

The largest individual community within the Marine Corps’ OpFor is the infantry. The infantry includes many specialties, both officer and enlisted, which work together to close with and destroy the enemy. When the Marine units deploy, they operate as a MAGTF, a fighting organization with organic ground combat, aviation, logistical, and command capabilities. The core of the MAGTF is the Ground Combat Element, and the core of the Ground Combat Element is the infantry.

Across the Marine Corps, there are four infantry regiments. Each regiment contains three battalions, and the regiments in 1st MARDIV contain four battalions each. Table 1.1 shows which battalions belong to which parent commands.

Each infantry regiment is referred to by its number, and each battalion is referred to by a “V,” its battalion number within its parent regiment, and its parent regiment’s number. As an example, 2nd Battalion, 6th Marines is the second battalion within the 6th Marine Regiment, and is designated “V26.” The extra battalions in each of the 1st MARDIV are all designated in 4th Marine Regiment, though the 4th Marine Regiment is not actually

Table 1.1. Battalion and Regimental Parent Command Structure.

MEF	MARDIV	Regiment	Battalion
I MEF	1st MARDIV	1st Marines	V11, V21, V31, V14
I MEF	1st MARDIV	5th Marines	V15, V25, V35, V24
I MEF	1st MARDIV	7th Marines	V17, V27, V37, V34
II MEF	2d MARDIV	2nd Marines	V12, V22, V32
II MEF	2d MARDIV	6th Marines	V16, V26, V36
II MEF	2d MARDIV	8th Marines	V18, V28, V38
III MEF	3d MARDIV	3rd Marines	V13, V23, V33

their parent command. Each regiment and its subordinate battalions are entirely located at a single base, and with the exception of 7th Marines, all regiments within a division are located at a single base.

Infantry Military Occupational Specialties

Enlisted infantry Marines are broken into Military Occupational Specialties (MOS). For Marines below the rank of Staff Sergeant, these specialties have unique capabilities and perform specific functions within the fighting unit. Upon promotion to Staff Sergeant, all Infantry Marines change to Infantry Unit Leaders (0369), regardless of their prior MOS, and continue with that specialty through their career. Some high-performing Sergeants may also earn the MOS of Infantry Squad Leader (0365). This MOS also consolidates from the other specialties, but upon promotion to Staff Sergeant the Marine will change to Infantry Unit Leader. Table 1.2 shows the available enlisted infantry MOSs and which paygrades hold them. This research will focus on the supply and demand of the above ranks and

Table 1.2. Infantry Military Occupational Specialties Adapted from CG, TECOM (2016).

MOS	Name	Ranks
0311	Rifleman	E1-E5
0331	Machine Gunner	E1-E5
0341	Mortarman	E1-E5
0351	Assault Marine	E1-E5
0352	Antitank Missile Gunner	E1-E5
0365	Infantry Squad Leader	E5
0369	Infantry Unit Leader	E6-E7

MOSs across both the OpFor and the rest of the Marine Corps in order to ensure optimal

utilization of the force.

Structure of an Infantry Battalion

The infantry battalion is the basic unit of the Ground Combat Element (DC CD and I 2015). Infantry Marines are assigned to the OpFor at the battalion level, and units typically deploy at the battalion level. Thus, the structure and manning of the infantry battalion is the primary focus of this research. Figure 1.7 shows the structure of the typical infantry battalion.

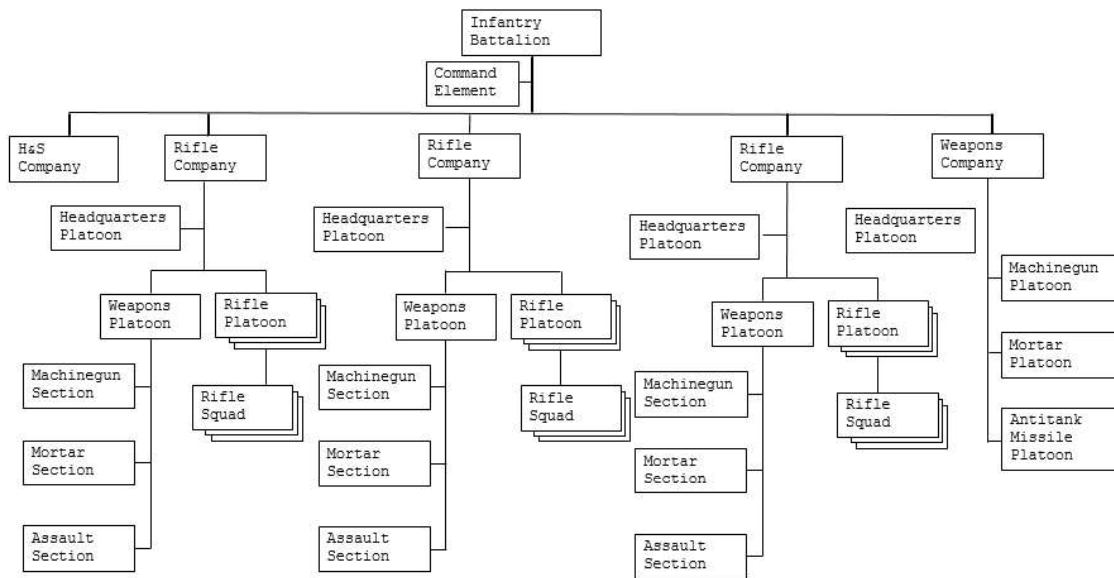

Figure 1.7. Organization of a Typical Infantry Battalion DC CD and I (2015).

The battalion contains a H/S Company, three rifle companies, and one weapons company. The H/S company contains primarily non-infantry MOSs which provide administrative, logistical, and other support to the battalion.

The rifle companies are made of a headquarters platoon, three rifle platoons, and one weapons platoon. Unlike the battalion H/S company, the headquarters platoon is made up primarily of infantry Marines from multiple MOSs. The rifle platoons have a headquarters element, and three rifle squads each with 13 0311 riflemen. The weapons platoon contains a headquarters element, a machinegun section with 21 0331 machine gunners, a mortar

section with 9 0341 mortarmen, and an assault section with 12 0351 infantry assault Marines. The weapons company contains a headquarters platoon, a heavy machine gun section with 0331 machine gunners, an antitank guided missile platoon with 0352 antitank missile gunners, and an 81mm mortar platoon with 0341 mortarmen (DC CD and I 2015).

Deployment Rhythm

Marines either deploy within units or as individuals. Typically, infantry units deploy as battalions, and outside of combat operations, units deploy on a regular timeline on three rotational deployment types:

- Unit Deployment Program (UDP): Battalion deployment from home station to Okinawa, Japan to be attached the 4th Marine Regiment for operational requirements in PACOM. This deployment is six months in length.
- Special Purpose Marine Air-Ground Task Force (SPMAGTF): Battalion deployment to operational commanders in support of Crisis Response and Theater Security Cooperation missions. II MEF battalions deploy to European Command (EUCOM), and I MEF battalions deploy to Central Command (CENTCOM). This deployment is six months in length.
- MEU: The infantry battalion forms the nucleus of a larger battalion landing team. Marines deploy aboard Navy ships, and are able to move between Combatant Commands in order to respond to contingencies as necessary. This deployment is typically seven months.

Prior to deployment, each battalion must be manned with qualified Marines and trained to complete its Mission Essential Tasks (METs). In order to allow enough time to build unit cohesion and allow training completion, units are stabilized six months prior to deploying, meaning that all Marines who will deploy with the unit have arrived and those who will not have departed (DC, M/RA 2011).

Any time an OpFor unit is not deployed is considered dwell time. This allows the units' Marines to reintegrate with their families and society as well as allowing the unit to integrate and train new Marines for its next deployment. MARADMIN 346/14 outlines the USMC policy on the deployment-to-dwell ratio. The ideal ratio is 2 months of dwell time for each month of deployed time, and the mandated minimum ratio, waiveable only by the

Secretary of Defense (SECDEF), is one month of dwell time for each month of deployed time (Director, Manpower Plans and Policy 2018). This policy applies to both units and individuals. Unit deployments are scheduled to meet these guidelines, and Manpower and Reserve Affairs (M/RA) policy allows exceptions for individuals only when they volunteer.

Fleet Tours and B-Billets

Infantry Marines do not spend all of their time in deployable OpFor units. Typically, they alternate between deployable OpFor tours and non-deployable B-Billets. These B-Billets vary widely, but allow the Marine to gain greater understanding of the larger Marine Corps and provide the perspective of infantry Marines to other parts of the Corps. For the purposes of this research, model constraints will be added to ensure that Marines are alternating between OpFor billets and B-Billets.

1.2.4 Adjustments for this Research

MCRP 5-12D structures the Marine Corps into HQMC and Supporting Activities, OpFor, and SE. However, this research specifically focuses on the interchange of individual Marines between deployable FMF tours and non-operational tours. In order to better achieve this goal, we will split into FMF which contains deployable battalion and regimental units, MCSFR, and SE which will include HQMC and Supporting Activities, SE, and those OpFor units which do not regularly deploy—component command staffs, division staffs, and MEF staffs. This represents policy laid out in Marine Corps Order (MCO) 1300.8 and will better match the rhythm of assignments within the infantry community and improve results (DC, M and RA 2014).

1.3 Marine Force Structure and Assignments

There are two linked Marine Corps processes which govern the who, what, when, where, and why of assigning Marines to units. The Total Force Structure Process (TFSP) establishes the human and material structure of the Marine Corps by balancing capabilities, requirements, and financial resources. The Force Generation Process (FGP) coordinates the assignment, preparation, and deployment of individual FMF units to geographic Combatant Commanders (CCDRs). Together, these processes assess the current and future requirements upon

the Marine Corps, develop the unit structures necessary to meet the requirements, builds those units, and assigns them to deployments to meet those requirements.

1.3.1 Total Force Structure Process

MCO 5311.1E states the purpose of the TFSP is to “translate necessary organizational capabilities into force structure solutions and measure the cost of providing those capabilities consistent with financial resources available to the CMC” (Director, Marine Corps Staff 2015). It consists of both “top-down” and “bottom-up” components. HQMC translates the National Security Strategy, Department of Defense (DoD) strategic documents, and guidance from the CMC to provide the “top-down” guidance. Simultaneously, the Components and MEFs in the OpFor make recommendations based on the capability requirements for their geographic and functional responsibilities. The output of this dialogue are METs, which are specific high-value tasks a type of unit must be capable of performing.

Force Structure is the responsibility of Deputy Commandant (DC) Combat Development and Integration (CD/I). It is defined as the manpower and equipment required by a unit to meet its METs. It is comprised of “units, billets, and equipment” (Director, Marine Corps Staff 2015). As an example, the structure of 1st MARDIV will include a set of equipment, individual Marines to fill its staff roles, and a set of subordinate units each of which has its own force structure and METs. This modular system allows the Marine Corps to respond to any sized contingencies around the globe without the need to modify existing unit personnel and equipment. The basic framework for Force Structure is the Table of Organization and Equipment (TO/E).

Table of Organization and Equipment

TO/E is a comprehensive listing of all personnel, subordinate units, and equipment necessary for a unit to remain capable of meeting its METs (Director, Marine Corps Staff 2015). It has three parts: Unit Identifier Codes (UIC), Billet Identifier Codes (BIC), and Table of Authorized Material Control Number. Only UICs and BICs relate to personnel within the unit. UICs go down to the Company/Battery level and are nested in parent-child relationships with higher and subordinate units; each unit with a UIC has its own set of required capabilities. BICs identify the individual roles required by the unit in order to achieve its capabilities. Each BIC is associated with a rank and MOS required to properly

fill that role. For a parent unit, the TO/E will contain the UICs of child units and the BICs of Marines which fall directly within the parent unit so as to prevent double-counting of personnel structure. By combining the parent BICs and the BICs from child UICs, one is able to build a TO/E for an entire unit (Director, Marine Corps Staff 2015).

Authorized Strength Report

Often, budget restrictions result in a mismatch between the manpower required by the TO/E and the congressionally authorized end strength. With this in mind, the CMC issued MCO 5320.12H Manpower Precedence Levels (MPL). This document outlines the priority for manning for each unit in the Marine Corps. It has four levels; each level specifies which units hold that priority as well as the “red line” below which that unit will not be manned. Those levels are:

- **Excepted Commands** are “those commands that fill a vital or mandated need” (DC, CD and I 2017). These units will be manned at 100% at all times. Examples include the MCSFBs which protect strategic assets in Kings Bay and Bangor.
- **OpFor Commands** are “integral to operational needs.” The order identifies the red line at 97%, but qualifies they will be “manned at a percentage... that will best meet the operational tempo while still supporting the other competing needs of the Marine Corps.” This qualification allows the Marine Corps to increase the manning of OpFor units prior to deployment, and free up manpower from recently returned units to fill other requirements. Leveraging the flexibility of this section of the Marine Corps is a major focus of this research (DC, CD and I 2017).
- **Priority Commands** are neither excepted or directly integral to the OpFor; however, they perform a “significant function.” These units are to be manned at or above 95%. Many of these units are part of HQMC and its Supporting Activities (DC, CD and I 2017).
- **Proportionate Commands** are those commands which are neither Excepted, OpFor, or Priority. These units are to be manned at or above 94% for enlisted Marines. These units are primarily the Supporting Establishment, though some are Supporting Activities (DC, CD and I 2017).

DCCD/I will take as inputs units’ TO/E, the MPL, and the total manpower strength and will output an Authorized Strength Report (ASR). This semiannual document is a running

resource allocation outlining affordable manning for the Marine Corps. This authorized strength “represents the ideal manning allocation,” which is less than or equal to the TO/E, and is the realistic goal to which individual Marines will be assigned to units (Director, Marine Corps Staff 2015).

1.3.2 Force Generation Process

The SECDEF and Joint Staff utilize the Global Force Management (GFM) Process to allocate units for deployment to geographic CCDRs based on “force availability, capacity, and readiness” (DC PP and O 2015). With input from CCDRs and service chiefs, this process forecasts and prioritizes the operational requirements of the CCDRs, assesses the capability and readiness of each Service to support these requirements, and assigns units to deploy to Combatant Commands. The Marine Corps’ inputs to GFM are called the Force Synchronization (FS) and FGP (DC PP and O 2015).

Force Synchronization Conference

The USMC uses FS to resource operational requirements through existing units or forming new units (DC PP and O 2015). Technically a step within the FGP, this process begins with the Force Synchronization Conference. Led by CG MARFORCOM, Marine Corps leaders meet to discuss operational requirements from the GFM, assess which units or individuals have the capabilities to meet the requirements, and assign those units or individuals to deploy in support of the requirement. Once a requirement has been assigned, the FS continues by scheduling milestones for manning, training, and resource readiness in order to ensure the unit can deploy within the scheduled timeline (DC PP and O 2015). Once units have been assigned missions, the Marine Corps will begin generating the force within the required timeline.

1.3.3 Force Generation Process

Once an FS solution is approved by the FS conference, the Marine Corps begins to man the assigned units (DC, PP and O 2013). At this point, responsibility shifts from MARFORCOM and CD/I to M/RA. This office is responsible for tracking the actual manpower at each unit and assigning Marines to fill its BICs.

In contrast to the TFSP which uses UICs as the basic unit structure, the manning process uses Monitor Command Codes (MCC). This code represents the level at which individual Marines receive orders to report, typically the battalion level or higher vice the company level represented by UICs. Additionally, M/RA is not concerned with the role each assigned Marine fills in the unit; instead, it focuses on the total number of Marines are required at each rank and MOS.

Finally, M/RA must balance the fluctuating requirements set out in the FS for the OpFor with the continual manpower requirements upon HQMC and SE units. To do this, they use the MPL and ASR in order to focus manpower resources on the highest priority units.

Staffing and Assignments

M/RA will assign Marines to MCCs in accordance with the budgetary layout from the ASR. The semi-annual ASR represents the ideal distribution of Marines across the force; this is commonly referred to as “manning” and represents which billets are authorized to be filled. However, the ASR does not take into account the career timing, exceptional family member requirements, and other real-life considerations which restrict M/RA’s ability to assign Marines to meet its goals exactly. To remedy this, M/RA fills the manning requirements in the ASR as closely as possible with the assignable inventory, known as the “staffing” process (Director, Marine Corps Staff 2015). The staffing level is always less than or equal to the manning level, which itself is less than or equal to the TO/E level.

In order to staff units, M/RA assigns individual Marines to that unit. This process involves ensuring the Marine is of the appropriate rank and MOS and has completed, or will, complete his current assignment. Typically, each assignment will be at least 36 months in length, with the exception of initial tours at MCSFR and overseas tours which are 24 months in length. There is no maximum length for an assignment (DC, M and RA 2014).

A Marine can receive one of two types of orders when he receives a new assignment. Permanent Change of Station (PCS) orders involve moving from one duty station to a new duty station. The Marine will receive a dislocation allowance in order to cover the costs of the move. Permanent Change of Assignment (PCA) orders change the Marines assignment while leaving him or her at the same duty station; in this case, the Marine is not paid a dislocation allowance as there is no requirement to move his or her belongings. MCO

1300.8 states that Marines should be given PCS orders only when absolutely necessary. Instead, preference should be given to PCA orders and low-cost PCS orders in order to minimize the cost to the service (DC, M and RA 2014).

1.4 Research Questions

The Marine Corps' main effort is the infantry. The rest of the service exists in order to support the ability of the infantry to "locate, close with, and destroy the enemy." Further, the infantry's main effort is the rifle squad, historically led by an E5 squad leader and three Fire Teams of 4 Marines each. Recently, Marine Corps leadership has recognized a need to change this basic structure in order to meet the future requirements outlined in the MOC. Current proposals include changes to either 12 or 15 man squads (HQMC 2018). Additional proposed changes include replacing Infantry Assault Marines with Combat Engineers and changing the number of Anti-tank Guided Missiles and medium mortars in the infantry battalion. Each of these changes will be assessed, validated, and if tactically successful implemented across the Marine Corps, but the organization must take care to understand the effects of these tactical changes across the entirety of the Marine Corps.

This research seeks to provide a tool to better understand how tactical structure changes will affect the ability to man the service as a whole. The following questions guided this effort:

1. Can a model be built to assess the effects of Force Structure changes on the ability to staff that structure?
2. Can the current end strength of the Marine Corps' Infantry population support its current Force Structure?
3. How does increasing or decreasing the number of operational deployments effect the staffing levels of non-operational units?

The difficulty in modelling this process is the need to ensure that all solutions provide integer answers as fractional answers would imply an ability to split Marines into parts. Previous attempts to optimize the process have used Mixed Integer Linear Programs (MILP). This approach represents each possible type of Marine as an integer variable. By only allowing the variables to take integer values, the model guarantees that the solution found will be integer. The MILP is simple to formulate but is extremely slow when considering a problem as large as the FGP since every feasible solution must be checked individually.

Instead, this model modifies current approaches to utilize network flow optimization which allows variables to take any positive real value. This approach is significantly faster than MILP since the continuity of the variables ensures continuity of the feasible solutions. With continuous solutions, the model can leverage gradients to assess only those solutions which are better than the current solution.

THIS PAGE INTENTIONALLY LEFT BLANK

CHAPTER 2: Previous Work

The USMC and DoD have spent significant resources searching for the best way to design the force structure and to assign service members to the appropriate billets. This process naturally lends itself to mathematical optimization. DC CD/I establishes TO/Es based on required capabilities, then builds optimization models to assign the current available force and build the ASR. After the ASR, M/RA uses human specialists to assign specific Marines to billets. Most often, the models used are either heuristic or integer programming models. There is no guarantee that heuristics provide the best solution while the large size of the service, both in number of personnel and specialties, make the integer programming models computationally infeasible. The sections below discuss past research in Marine Corps assignments and research into network flow optimization.

2.1 Past Manpower Research

As a manpower management officer, Annunziata's research focused on the policy failings of the current system (Annunziata 2018). She found the partitioning of the FGP between multiple DCs hindered the effective manning of deploying units (Annunziata 2018). Although solution was the consolidation of these processes under one DC, but her ideal endstate was a logical system in which the TFSP, FSP, and FGP integrated smoothly with each other.

Freeman 2018 sought to maximize the amount of time a unit was staffed prior to deployment. In his ambitious model, he used a heuristic to assign units to deployments and a random forest to assign individuals to units (Freeman 2018). This process did well to predict individual assignment to deploying units, but did little to assess the availability of Marines for supporting establishment units.

In the thesis most closely aligned with this research, Captains Ostrin and Hooper showed how a mathematical model can improve the assignment process versus human assignment (Hooper and Ostrin 2012). They used an integer linear program to assign 15 Marines and compared the results to the actual assignments. This research proved the applicability of mathematical programming to the manpower assignment process. However, their integer

programming approach cannot scale to assign the thousands of Marines who change units annually.

2.2 Network Flow Models

Optimization centers on how to algorithmically find the best solution among many possible solutions. In particular, the problem of assigning workers to tasks is common throughout optimization literature. Assignment models commonly have one shortcoming: they are MILP. MILPs are useful because they do not allow fractional answers, so there is no worry of half of Marine assigned to a unit; however, the restriction to integer answers also makes these problems difficult, sometimes requiring exponentially many calculations with current algorithms. In fact, it is NP-hard to find the global optimal solution for a MILP problem (Lenstra 1983).

A solution is to use a network flow model. This method combines the traditional continuity assumption of Linear Programs (LP)—which allow solving without manually checking every option—while ensuring that all answers are integer. Such a formulation usually trades the number of required computations for memory.

In order for a model to achieve the benefits of a network flow, all variables must represent the flow of some commodity on a set of arcs and the right-hand side of all constraints must be integer. Additionally, all constraints must be one of two types:

1. A balance of flow on a node, that is balancing the flow into a node with the flow out of the node and the supply or demand of that node. This ensures the commodity demand is met at the node and that the quantity of each commodity is preserved within the model.
2. A capacity constraint on a single arc.

If for all constraints, the balance of flow is equal to an integer, and for all edges the capacity upper bound is an integer, then the model has “network structure” and linear programming algorithms with yield integer solutions (Van Roy and Mason 2008).

This is in contrast to MILPs, which require more complicated algorithms to solve for integer solutions. As long as the “flow” variables in a network flow model satisfy constraints which

force integer equality, they will be integer.

2.2.1 Example

The standard introduction to network flow optimization is a transportation problem. Consider an airline which has passengers who want to travel to various cities around the country. The airline will try to get passengers to their destination for the lowest possible cost. Often, this requires routing passengers through connecting airports, with each leg of the flight having a particular cost for the airline to fly.

Suppose the airline has a network of three airports—San Francisco, Los Angeles, and Las Vegas. All airports are connected with the following costs:

- San Francisco to Los Angeles: \$200.
- San Francisco to Las Vegas: \$300.
- Los Angeles to Las Vegas: \$100.

The airline also has passengers who want to fly to both Las Vegas and Los Angeles on a particular day from San Francisco. The airline will then want to optimize which flights to schedule. The options in this example are to offer flights directly to Las Vegas from San Francisco or to route all traffic through Los Angeles.

In this simple example, it costs \$300 to route all traffic through Los Angeles and \$500 to offer direct routes to both destinations. Thus, it is clear the airline would only route flights through Los Angeles.

The problem becomes more difficult when all airports in the country and all possible start and destination points are considered. The mixed integer approach would be to model the entire network and test the cost of each possible combination of routes, eliminating possibilities one by one. Only once every combination of routes has been considered can the airline be sure it has created the best network.

The network optimization approach is different. The model has every possible route “on,” and allows passengers to “travel” all routes. It achieves the best possible solution by minimizing the total cost across the entire network. By not restricting variables to integer values, at each step it can utilize the cost gradient to find the variable —flow across an

arc—which needs to change in order to improve cost. Thus, the network approach does not require checking every possible integer solution. Instead, it finds the best possible solution, which will be integer based on the constraints having network flow structure.

CHAPTER 3: Data

This research leveraged a variety of current and historical manpower data, including current individual assignments, historical promotion data, historical deployment data, and recruiting and retention goals. The data was collected directly from M/RA and the Total Force Data Warehouse. This section will introduce the data gathered and discuss its relevance.

3.1 Historical Data

The historical data served two purposes. First, some replaced current or future data which is classified; using historical data allows the process to be modeled accurately while keeping distribution as wide as possible. Second, some data was highly variable from year-to-year which suggested the use of averages vice only the current distribution.

3.1.1 Deployment Data

Deployment data was collected from 2014 to Present (CNA 2019). The data included MCC, type of deployment, start date of deployment, and finishing date of deployment. The model replicates the historical rhythm of deployments from January 2015 to December 2018 (CNA 2019). January 2015 was chosen as the start date because the current data was pulled in January of 2019, matching seasonality, and because 2015 was the first year without combat deployments to Afghanistan, matching the current rotational deployment rhythm. Historical data was used for this requirement due to the classification of future deployment data; a production model should use projected deployment for improved utility.

3.1.2 Promotion Data

Promotion data was provided from 2006 to Present by the M/RA Enlisted Promotion Plans Office (Beindorf 2018). The data is indexed by rank, MOS, and year-month of promotion with values for average Time-in-Service and number promoted for each rank-MOS combination (Beindorf 2018). This data was averaged by month from 2012 to present

in order to build a forward-looking estimate for number of promotions for each month of the year.

3.1.3 Separations Data

Separations data covered the number of Marines by rank and MOS separating from the USMC between January 2006 and December 2018 (MIR 2019). The data from 2012 to present was used, again averaging for month for each rank-MOS combination in order to provide a forward-looking estimate for the model.

3.1.4 Infantry Marine Production

Infantry Marine Production data logged the number of Marines graduating from infantry-MOS producing schools annually between 2014 and 2018 (Jaunal 2019). Data was broken up into East and West coast Schools of Infantry and by MOS. The number of Marines was consolidated into a single value for each MOS, was averaged across years, and graduated were assumed to be uniformly split among months. The exception was the 0351 Infantry Assault Marine MOS. In 2018, the CMC announced a reorganization of the ground combat element which reduced the number of 0351s required (HQMC 2018). This policy change resulted in a drop in production between 2017 and 2018, thus only 2018 production values were used for the Infantry Assault Marine MOS.

3.2 Current Data

The current data sets was used to set the initial conditions for the model. Data sets were used to both design the structure of the model and set the initial distribution of Marines across the Corps.

3.2.1 Tables of Organization

Tables of Organization were used to build the ideal structure of Marines by rank and MOS at each MCC. The data was provided for 2018 and included MCC, MOS, and number of Marines by rank required for the TO/E (Larger 2019). The TO/E was used as is for current structure. 18 E4 and 18 E3 riflemen were added to each infantry battalion for future force structure in order to assess the impact of the fifteen-man rifle squad.

3.2.2 Manpower Precedence Levels

Manpower Precedence Levels were determined in accordance with MCO 5320.12H. Units were itemized by UIC and split between Excepted, Operational, Priority, and Proportionate commands. Each UIC was consolidated into its parent MCC in the model. When precedence conflicts existed, the higher precedence was used for the entire MCC. Some Operational units were switched to Priority precedence in the model in order to separate rotationally deploying units from operational staffs; the red-line percentage in MCO 5320.12H was identical for both populations, so this adjustment did not affect the outcome of the model.

3.2.3 Infantry Force Data

Infantry Force data set the current locations of the target population across the Marine Corps. The data contained the number of Marines by rank and MOS currently assigned to each MCC in the service (MIR 2019). This data was used to seed the initial conditions for the model.

THIS PAGE INTENTIONALLY LEFT BLANK

CHAPTER 4: Methodology and Formulation

The methodology outlined below allows traditional Linear Programming fundamentals while ensuring integer outcomes. Traditionally, linear programming utilizes inequality constraints (e.g., \leq , \geq). This allows flexibility in the model to combine solutions as necessary to achieve an optimal result. The downside is that often the optimal result is made with fractional values which is not useful when discussing individual Marines which cannot be split into fractions. The usual solution to achieve integer solutions is to use Integer Programming, restricting variables to integer values. The downside of this approach is that the optimal solution is NP-hard with current algorithms (Lenstra 1983).

The solution proposed in this research is a network flow model. Adapting the previous MILP models to a network flow requires two changes. First, all variables are relaxed from integer values only to allow all real values. This allows continuity of variables and continuity of feasible solutions. Second to allow for disparities between current population and force structure, the model includes elastic variables (Brown and Wood 1997). These allow units to have excesses or shortfalls from their structure and maintains feasibility when the population differs from the structure.

4.1 Basic Model Structure

This section will discuss the top-level structure of the model in order to build a basic understanding before the detailed formulation. Figure 4.1 shows simplified diagram of the network structure. The grey circles represent sets of units by MCC which hold Marines in their structure. The green circle represents the ELSs and serve as the source for new Marines entering the system. The red circle represents End of Active Service (EAS)s and serves as the sink for removing Marines from the system based on historical patterns. The yellow circle represents Transients, Trainees, Patients, and Prisoners (T2P2) and serves to control the movement of Marines between the FMF, SE, and MCSFR. The arrows represent possible flow paths in the network. Promotion nodes were omitted to improve clarity, but each promotion node will go into and out of all nodes in each of the grey circles, allowing promotion from any unit.

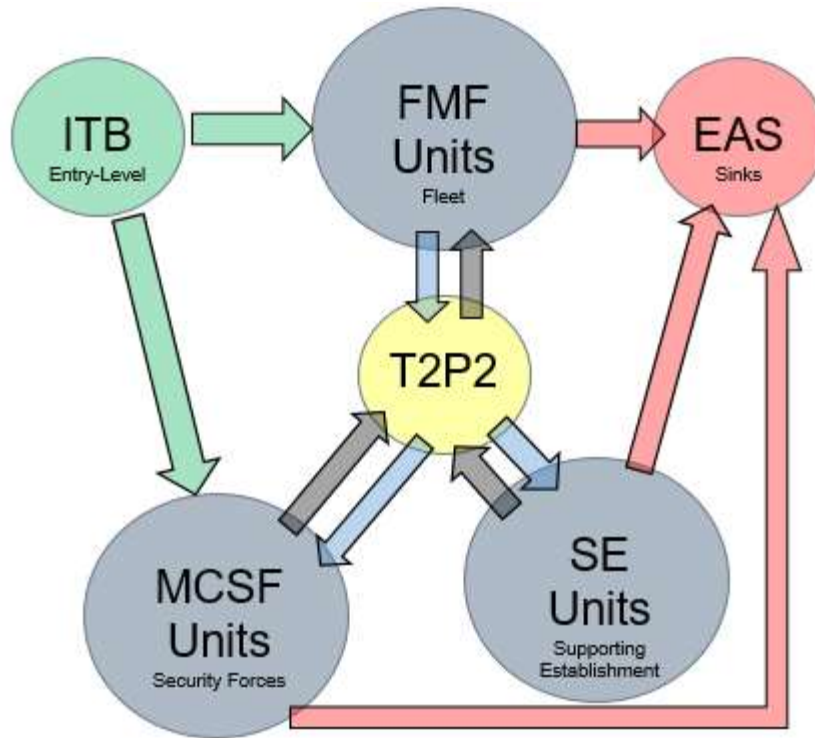

Figure 4.1. Basic Structure of Total Force Network Flow Model.

The model as shown is repeated for each of 36 months. Nodes are indexed by month, and connections between units occur month-to-month in order to represent the inertia of adjusting the population to the target structure. The special nodes — ELS, T2P2, EAS, and promotion — connect to units of the same month.

The rank-MOS commodity distribution of the population is maintained by constraining the flow on each unit; the flow of each commodity into each node must be equal to the flow out of the node. This both preserves the population in the model and enforces requirements of the network flow optimization (Lenstra 1983). There is no “flow-in” to ELS nodes. Instead, the flow-out of the source nodes is equal to the historical number of each MOS to graduate from ELS for the specified month of the year (Larger 2019).

The opposite is true of EAS nodes. They have no “flow-out,” and their “flow-in” is set equal to the historical average number of each rank-MOS combination to EAS in the represented month (MIR 2019). Promotions are restricted to the historical number of promotions for each rank-MOS combination. The “flow-out” of each promotion node is set equal the

historical average number of promotions for that rank-MOS (Beindorf 2018). Using “flow-out” allows Marines to switch MOSs on promotion, useful for “0365” and “0369” which are created by promoting junior Marines from a variety of other MOSs.

The units themselves have values equal to the TO/E structure multiplied by the units’ “red-line” value established in the MPL. The rank-MOS commodity “flow-in” is set equal to the commodity’s goal value, with extra variables for excesses and shortfalls of Marines in order to maintain balance and allow for failures to match the set structure. The model seeks to minimize these shortfalls.

The modular nature of the model allows planners to manipulate data and structure to represent policy changes. Promotion, accession, and retention can be changed by adjusting the deterministic values. Deployments can be changed by scheduling units for stabilization. Structural changes can be represented by changing the goal values for particular units or types of units.

4.2 Indices

The model seeks to optimize the assignment of enlisted rank-MOS combinations from Table 1.2. The optimization is done over a 38-month time period; 2 months were left for burn-in and 36 months for execution. The list below outlines the model’s index structure:

- *i* — Nodes: each of the nodes below is replicated for 38 months in order to model the time progression:
 - The 263 MCCs which hold the target population in their TO/E.
 - A combined East and West coast ELS node to source of new Marines.
 - An EAS node as a sink to remove Marines from the model.
 - A promotion node to change the rank commodity. When transitioning from “E5” to “E6,” the MOS commodity changes to “0369.”
 - A squad leader node to promote “E4” Marines to “E5” and change to the “0365” Infantry Small Unit Leader MOS. Promotions from “E4” to “E5” within the same MOS use the standard promotion node.
 - A T2P2 node to control PCS moves and ensure alternation between FMF and SE units. This node represents only the transient population and not the entire T2P2 population.

- i, j — Arcs: All nodes connect to themselves month-to-month. Remaining arcs have a single direction and follow the rules below:
 - Source nodes connect to all nodes with FMF and MCSFR of the same month. This represents the standard that Marines graduating from ELS will immediately to either a deploying unit or a MCSFR unit.
 - FMF nodes connect month-to-month to other FMF nodes within the same MEF. This represents M/RA’s ability to move Marines within the same duty station with PCA orders.
 - MCC nodes connect to promotion, squad leader, and sink nodes of the same month. This allows promotion within the month, as well as removing Marines from active service in order to balance the population in the model.
 - MCC nodes connect to T2P2 nodes month-to-month.
 - T2P2 nodes connect to MCC nodes of the same month. This represents a single-month transition between units.
 - Promotion and squad leader nodes connect to MCC nodes of the same month. This represents a Marine being promoted without removing him or her from the unit’s population.
- Commodities: The possible characteristics of the target population are represented as commodity types by the indices below:
 - m — MOS: The commodity to represent the Marine’s specialty.
 - r — Rank: The commodity to represent the Marine’s rank.
 - $prank$ — Primary Rank: The actual rank of a Marine.
 - $brank$ — Billet Rank: The rank of the TO/E billet space filled by a Marine.
 - $pmos$ — Primary MOS: The actual MOS of a Marine.
 - $bmos$ — Billet MOS: The MOS of the TO/E billet space filled by a Marine.

4.3 Sets

The nodes, arcs, and commodities above were collected into sets for ease of reference in the model:

- I : The set of all nodes.
- A : The set of all arcs.
- M : The set of possible MOS: “0311,” “0331,” “0341,” “0351,” “0352,” “0365,” and

“0369.”

- *R*: The set of possible ranks: “E3,” “E4,” “E5,” “E6,” and “E7.” Marines in ranks “E1” and “E2” are counted in “E3.”
- *commods*: The commodities set contains all possible (*m*, *r*) pairs and ensures that any MOS represented is matched by a rank which can hold the specialty. This reduces the number of pairs required and improves memory usage.

4.4 Parameters and Data

Parameters are used to define the immutable structure of the network model. Data represents current policy, manpower and structure and can be manipulated to test policy changes.

4.4.1 Parameters

- $cost_{(i,j)}$: The cost to move between node *i* and *j*.
 - $cost_{(i,j)} = 0$ if moving between the same unit.
 - $cost_{(i,j)} = 2$ if moving between FMF units in the same MEF in a PCA.
 - $cost_{(i,j)} = 1$ if moving to or from T2P2 nodes in a PCS.
 - $cost_{(i,j)} = 0$ for moving from ELS, to EAS, or to and from promotion nodes.
- pen_i : The penalty paid for not having the required the number of Marines of appropriate rank-MOS combination.
 - $pen_i = 100$: A penalty of 100 is applied to each shortfall in Excepted Commands.
 - $pen_i = 25$: A penalty of 25 is applied to each shortfall in Priority Commands.
 - $pen_i = 10$: A penalty of 10 is applied to each shortfall in Proportionate Commands.
 - $pen_i = 25or1$: A penalty of 25 is applied to each shortfall in stabilized FMF commands and 1 for each shortfall in non-stabilized FMF commands.

4.4.2 Data

- $start_{i,m,r}$: The starting number of Marines of MOS *m* and rank *r* in a unit.
- $goal_{i,m,r}$: The staffing goal of each MCC. This number is calculated by multiplying the “red-line” percentage from MCO 5320.12H by its TO/E. This value is then rounded to the nearest integer in order to preserve the network optimization.

- $stab_i$: A binary number representing an FMF unit's stabilization status during month d . When stabilized, the FMF unit's $pen_i = 25$. When not stabilized, the unit's $pen_i = 1$.
- $source_{m,i}$: The number of Marines of MOS m to graduate ELS in month d .
- $sink_{m,r,i}$: The number of Marines of rank r and MOS m to EAS in the month associated with i .
- $promot_{m,r,i}$: The number of Marines to promote to rank r and MOS m in the month associated with i . This number represents all rank-MOS pairs except "E5"- "0365."
- sl_i : The number of Marines to promote to rank "E5" and MOS "0365" in the month associated with i .

4.5 Variables

The model contains three types of variables. A primary flow variable to track the actual number of Marines in the target population and two variables to measure the difference between the current number of Marines in a unit and the goal number. A key difference from integer programming models, each of these variables is allowed to take any positive real value. The constraints will force the result to be integer, and therefore useful when considering the indivisibility of Marines.

- $X_{i,j,m,r}$: The model's flow variable represents the number of Marines of rank r and MOS m moving from node i to node j . This variable is initialized to $start_{i,m,r}$.
- $eX_{i,pmos,bmos,prank,brank}$: The excess flow variable. This variable represents the positive difference between X and $goal$, and it allows that excess to be used to fill shortfalls in other ranks and MOSs if necessary. This variable is initialized as 0.
- $sh_{i,m,r}$: The shortfall variable. This variable represents the negative difference between X and $goal$, and it tracks the inability of the Marine Corps to meet its structural requirements. This variable is initialized as 0.

4.6 Constraints

Constraints are used to build the rules of the model. These will enforce current policies and can be manipulated to test changes.

Flow Balance Rule

The most important rule in a network flow is the flow balance rule. This rule ensures that the number and type of Marines leaving each node is equal to the number and type entering the node, preventing the creation of extra Marines. This constraint is applied only to the nodes in the sets $T2P2$, FMF , SE , and SF as variables are either created or change commodities when flowing through the other nodes. The left side is the flow into the node, and the right side is the flow out of the node.

$$\sum_{j \forall (j,i) \in A} X_{j,i,mos,rank} = \sum_{j \forall (i,j) \in A} X_{i,j,mos,rank} \forall (mos, rank) \in commods \forall i \in FMF \cup SE \cup SF.$$

Promotion Flow Balance Rule

This constraint is adjusted from the Flow Balance Rule in order to allow the commodity to change when transiting the $Prom$ and $SqdLdr$ nodes. This constraint simply ensures the total flow in (left-hand side) is equal to the total flow out (right-hand side); ensuring the promotion is affecting the correct rank-MOS pairs is handled in a later constraint.

$$\sum_{j \forall (j,i) \in A} \sum_{mos,rank \in commods} X_{j,i,mos,rank} = \sum_{j \forall (i,j) \in A} \sum_{mos,rank \in commods} X_{i,j,mos,rank} \forall i \in Prom \cup SqdLdr.$$

Goal Rule

This constraint sets the authorized strength goal for each unit. The network flow requires equality constraints, so artificial shortfall and excess variables are utilized to allow and assess deviations of actual Marines from the goal. This constraint is formulated differently for two experiments. In the first and more complicated, Marines are allowed to fill billets one rank up or one rank down, a common practice. The second and simpler, Marines can only fill billets of their current rank and MOS. Although the second does not as accurately reflect current assignment policy, it is more informative when assessing the current ability of the Marine Corps to meet its structure. First, we will define holding variables for clarity:

- *FlowIn*: This variable counts the total number of Marines of a particular rank-MOS

pair actually in the unit.

$$FlowIn_{i,mos,rank} = \sum_{j \forall (j,i) \in A} X_{j,i,mos,rank}.$$

- *ExcessPure*: This variable is the excess number of Marines of a rank-MOS pair which are not used to fill billets of other ranks or MOS.

$$ExcessPure_{i,mos,rank} = ex_{mos,mos,rank,rank}.$$

- *ExcessOther*: This variable is the excess number of Marines of a rank-MOS pair which are used to fill billets of other ranks or MOS. *otherMOS* and *otherRank* are holding sets of possible ranks and MOS which the actual rank-MOS can hold.

$$ExcessOther_{i,mos,rank} = \sum_{otherMOS} \sum_{otherRank} ex_{mos,otherMOS,rank,otherRank}.$$

- *HelpOther*: This variable is the excess number of Marines from other rank-MOS pairs which are used to fill billets of the goal rank-MOS pair.

$$HelpOther_{i,mos,rank} = \sum_{otherMOS} \sum_{otherRank} ex_{otherMOS,mos,otherRank,rank}.$$

- *Shortfall*: This variable is the shortfall from the goal of Marines of the rank-MOS pair.

$$Shortfall_{i,mos,rank} = sh_{i,mos,rank}.$$

These holding variables are combined for the two formulations discussed:

- Experiment 1: This case allows excess Marines to fill other billets.

$$FlowIn_{i,mos,rank} - ExcessPure_{i,mos,rank} - ExcessOther_{i,mos,rank} + HelpOther_{i,mos,rank}.$$

$$+ Shortfall_{i,mos,rank} = goal_{i,mos,rank} \forall mos, rank \in commods \forall i \in FMF \cup SE \cup SF.$$

- Experiment 2: This case does not allow excess Marines to fill other billets.

$$FlowIn_{i,mos,rank} - ExcessPure_{i,mos,rank} + Shortfall_{i,mos,rank} = goal_{i,mos,rank}$$

$$\forall mos, rank \in commods \forall i \in FMF \cup SE \cup SF.$$

Source Rule

This constraint allows new Marines to enter the system by graduating ELS. The left-hand side is the sum of all Marines of the specified MOS moving from ELS to units in either *FMF* or *SF*. The right-hand side is the average historical number of graduates for the specified MOS for that month. All Marines graduate as “E3”; all other ranks have right-hand side equal to 0.

$$\sum_{j \in SF \cup FMF} X_{i,j,mos,E3} = source_{mos,d}, \forall i \in ELS, \forall mos \in M.$$

Sink Rule

The sink constraint allows Marines to leave the system via EAS. The right-hand side ensures is the historical average number of Marines of the specified rank-MOS pair to EAS in a given month. The left-hand side is the number of Marines of that rank-MOS pair to flow to the Sink node.

$$\sum_{j \forall (j,i) \in A} X_{j,i,mos,rank} = sink_{mos,rank,i}$$

$$\forall i \in EAS, \forall mos \in M, \forall rank \in R.$$

T2P2 Rule

The first rule ensures all Marines in the FMF PCS to the SE or MCSFR. The left-hand side is all Marines leaving the fleet. The right-hand side is all Marines entering either SE or MCSFR.

$$\sum_{jst(j,i) \in A \text{ and } j \in FMF} X_{j,i,mos,rank} = \sum_{jst(i,j) \text{ in } A \text{ and } j \in SE \cup SF}$$

$$\forall i \in T2P2, \forall mos \in M, \forall rank \in R.$$

The second rule ensures all Marines in the SE and MCSFR PCS to the FMF. The left-hand side is all Marines leaving the SE and MCSFR. The right hand side is all Marines entering

FMF.

$$\sum_{jst(j,i) \in A \text{ and } j \in SE \cup SF} X_{j,i,mos,rank} = \sum_{jst(i,j) \in A \text{ and } j \in FMF} X_{j,i,mos,rank}$$

$$\forall i \in T2P2, \forall mos \in M, \forall rank \in .R$$

Stabilization Rule

This rule ensures that no Marines leave a unit while it is stabilized for deployment. First, we define a holding set $Self_i = (i) \cup Prom \cup SqdLdr$. This set is all nodes a Marine can flow through while remaining in the deploying unit: itself, the promotion node, and the squad leader promotion node. Next, we define the constraint. The left-hand side flow into the node, and the right-hand side is the flow out of the node. In conjunction with the Flow Balance Rule, restricting the right-hand side to flow only to $Self_i$ ensures that Marines will remain in the unit upon stabilization.

$$\sum_{j \forall (j,i) \in A} \sum_{mos,rank \in commods} X_{j,i,mos,rank} = \sum_{j \forall (i,j) \in Self_i} \sum_{mos,rank \in commods} X_{i,j,mos,rank}$$

$$\forall i \in FMFststab_i = 1.$$

Promotion Rules

These constraints will control promotion in the network. The first rule applies to each node in $FMF \cup SE \cup SF$. It ensures the promoted Marines stay in their current unit and that the appropriate MOS and rank changes are made. The left-hand side is the number of Marines of the lower rank sent to p , the promotion node associated with i , and the right-hand side is the number of Marines returning from p . The first constraint applies to ranks “E4,” “E5,” and “E7” only, as there is no MOS change associated with these promotions.

$$X_{i,p,mos,lowerRank} = X_{p,i,mos,rank}.$$

$$\forall mos, rank \in commodsstrank \in ('E4', 'E5', 'E7'), \forall i \in FMF \cup SE \cup SF.$$

The second constraint applies to rank “E6,” in which all Marines of lower rank change MOS.

$$\sum_{mos \in M} X_{i,p,mos,“E5”} = X_{p,i,“0369,”“E6”} \forall i \in FMF \cup SE \cup SF.$$

The second rule applies to each promotion node in *Prom* and ensures the total number of Marines promoted in a month matches the historical averages. The left-hand side is all flow from the promotion node, and the right-hand side is the historical average number of Marines of the rank-MOS pair promoted in that month.

$$\sum_{jst(i,j) \in A} X_{i,j,mos,rank} = promot_{mos,rank,i} \forall mos, rank \in commods, \forall i \in Prom.$$

Squad Leader Promotion Rules

These constraints are similar to the Promotion Rules above; however, they only control the promotion of Marines to the MOS “0365.” In this case, $p \in SqdLdr$ is the squad leader node associated with i . The “0365” promotions were separated in order to preserve balance of flow for Marines to promote within their own MOS or to change to the “0365” MOS.

$$Sigma_{mos \in M} X_{i,p,mos,“E4”} = X_{p,i,“0365,”“E5”} \forall i \in FMF \cup SE \cup SF.$$

The second constraint applies to each squad leader promotion node. The left-hand side is all flow from the promotion node, and the right-hand side is the estimated number of Marines to promote to “0365” in the specified month, historical data was not available for this promotion.

$$\sum_{jst(i,j) \in A} X_{i,j,“0365,”“E5”} = sl_i \forall i \in SqdLdr.$$

4.7 Objective Function

The objective function allows the researcher to control the definition of an optimal solution with the defined constraints. In this case, the author sought to minimize the number cost of changes and the shortfall of Marines. The first term is the total shortfall and their associated

penalties; the second term is the flow of Marines and the cost of that flow.

$$\min_X \sum_{i \in I} \sum_{mos, rank \in commods} pen_i * sh_{i,mos,rank} + \sum_{(i,j) \in A} \sum_{mos, rank \in commods} cost_{(i,j)} * X_{i,j,mos,rank}.$$

CHAPTER 5: Results

The results of this research serve two purposes. First, they provide insight into the current proposal to change from a 13-man rifle squad to a 15-man squad. Second, they provide an efficient framework for analyzing future proposals to change the force synchronization, force generation, and total force structure processes.

The model — under current recruiting, retention, and rotational deployment conditions — showed that the change to a 15-man squad increased the structural shortfall in the infantry community by 82% and the number of unfilled billets by 34%.

5.1 Experiments and Cases

This research conducted two separate experiments, each with four cases. Experiment 1 only allowed Marines to fill billets of their own rank and MOS. This experiment sought to see how current manpower policies met the structural requirements of the community.

Experiment 2 allowed Marines to fill billets either one rank above or one rank below their primary rank. This more closely matches the reality of how units are staffed; the billets are filled by qualified Marines even if they are not the most qualified.

Together, the results of these two experiments provide an understanding of both how current policy can be modified to more closely match the structure, and whether the current structure is realistically workable when considering outside recruitment and retention issues.

The four cases in this research mimic policy changes and contingencies the Marine Corps will face in the future. Case I is the base case and considers a 13-man rifle squad and the historical rotational deployment rhythm from 2014-2017.

Case II is the 15-man squad case. This case utilizes the same deployment rhythm, but adds 27 “0311” “E3”s as SUAS operators and 27 “0311” “E4”s as assistant squad leaders. This case sought to understand how increasing the required structure affected the total shortfall across the infantry community.

Case III considered an increased deployment rhythm. Four net deployments were added to the historical rhythm each year — a total of twelve — in order to replicate the effects of a regiment-sized contingency operation. This case sought to understand how current structure and manpower projections were able to withstand an increased deployment rhythm.

Case IV considered both the increased deployment rhythm and the 15-man rifle squad. This case sought to understand how the larger structure would affect the supporting establishment during a regimental-sized contingency operation.

5.2 Results

The results of the experiment showed two major themes. First, increasing from a 13-man to 15-man squad increased the structural shortfall of Marines by 82% and the number of unfilled billets by 34%. Second, adding a regimental deployment had a minimal effect on shortfalls within the SE, an total increase of less than two Marines per month.

5.2.1 Experiment 1

Experiment 1 evaluated the supportability of the various structures by the current end strength. Specifically, how the rank-MOS commodity mix of the infantry force was able to fill the structure with the billet-designated rank-MOS Marines. Figure 5.3 shows the total shortfall and excess of each case in Experiment 1.

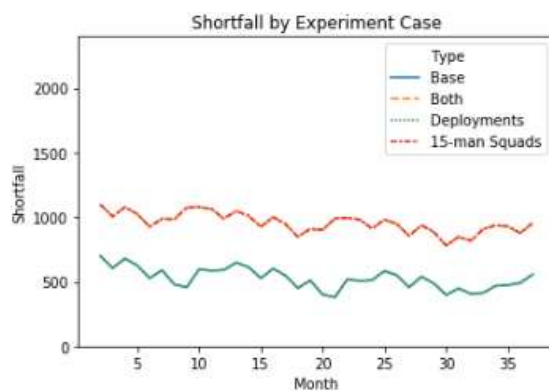

Figure 5.1. Total Shortfall.

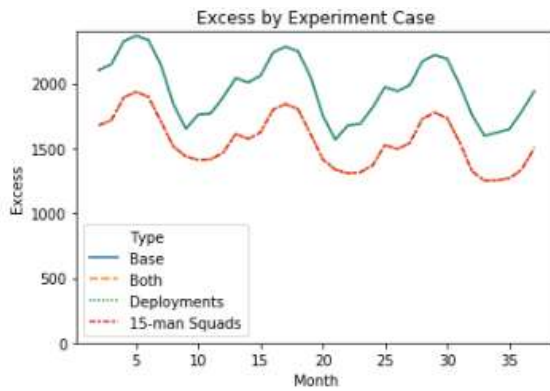

Figure 5.2. Total Excess.

Figure 5.3. The Structural Excess and Shortfall for Experiment 1. The Total for Cases I and III and Cases II and IV Are Virtually the Same.

The patterns for Cases I and III and Cases II and IV are virtually the same and appear so in the plot. The differences will be discussed further below. Notably, Figure 5.1 shows a fairly uniform pattern of structural shortfall while Figure 5.2 shows significant peaks and troughs but an overall downward trend. The downward trend was a result of the balancing of the population to the designated structure over time. The peaks and troughs were a result of higher EAS rates in the summer months, while ELS graduations were modelled as uniform throughout the year.

Shortfalls

Table 5.1 shows the increase in total shortfalls over the length of the 36-month experiment. The 15-man squad increases the total shortfall across the force by 82%, an increased shortfall of 431 Marines per month of the experiment.

Table 5.1. Total Shortfall by Component for 36-month Experiment.

Cases	Total	Fleet	SE	% Difference
Case I: Base	18,908	18,857	51	NA
Case II: 15-man Squad	34,440	34,384	56	82%
Case III: Deployments	18,909	18,799	110	<.01%
Case IV: Both	34,404	34,285	119	82%

The shortfalls themselves were not uniform across all components — FMF, SE, and MCSFR. In fact due to the concentration of high priority units, MCSFR had no shortfalls throughout the experiment in any Case. The vast majority of the shortfall existed within the Operating Forces. This was likely due to the lower penalty placed on shortfalls in non-stabilized OpFor units, there is no need to remain fully manned when not working towards or on deployment.

Table 5.1 shows that across all cases, the vast majority of shortfall occurs within the FMF. Counterintuitively, this total shortfall within the FMF is lower in Case IV — which includes extra deployments — than Case II — which does not; this is due to a greater shortfall within stabilized units. Figure 5.4 shows the shortfall within stabilized FMF units. Case II has a total shortfall of 2701 within stabilized units while Case IV has a shortfall of 5628 — a 108% increase with only a 20% increase in deployments. Even controlling for deployments, Case IV has a 34% greater stabilized shortfall than Case III with less than 3% increase in total structure. This change within stabilized units is troubling. The purpose of changing

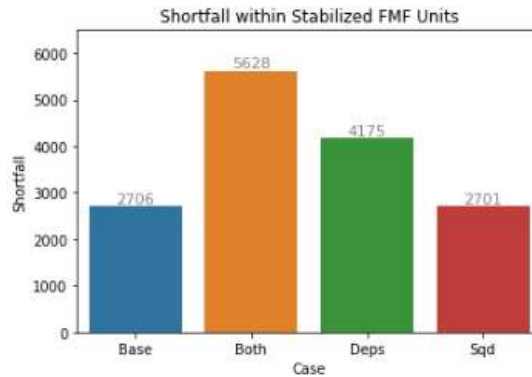

Figure 5.4. Shortfall Within FMF Units Stabilized for Deployment.

the squad size is to make the infantry more combat effective; however, in reality, the change results in a significantly larger shortfall within deployed operational forces.

This change was not uniform across all ranks and MOSs. Figure 5.5 shows the monthly shortfall by MOS. For Cases I and III, all MOSs other than “0351” go to 0 over the course of the experiment. This suggests that the current structure is supportable by the current end-strength, although the manning of that structure is not currently optimal. In particular, “0311” and “0365” begin with significant shortfalls across the Marine Corps, and decrease to near 0. This makes sense for “0365” as it is a new MOS whose billets are often filled by other Marines. However, the large shortfall for “0311”s shows that the current process for assigning that MOS leaves more shortfalls than necessary. The only MOS to increase is “0351.” This is the result of the ELSs producing fewer Marines of this MOS in anticipation of their future divestment. Case II and Case IV show a similar downward trend — implying

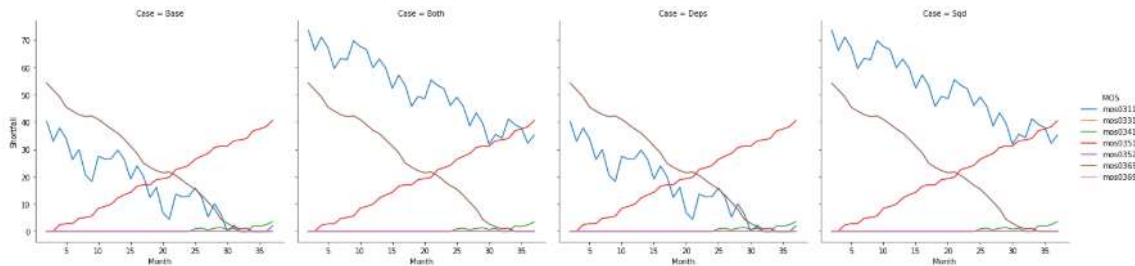

Figure 5.5. Monthly Shortfall by MOS for each Case.

possible improvements in the assignment process — across MOSs, but the “0311” MOS maintains a significant shortfall throughout the experiment. This is understandable and represents the fact that the only structure change was to add two “0311” Marines to each

rifle squad. Thus, even with gained efficiency in the assignment process, the current end strength of the “0311” MOS cannot support a transition to a 15-man squad.

Figure 5.6 shows the monthly shortfall by rank. For Cases I and III, “E4,” “E6,” and “E7” all maintain near 0 shortfall throughout the experiment. “E5” starts with a small shortfall which approaches 0, suggesting a better assignment policy for “E5”s is possible. For Cases

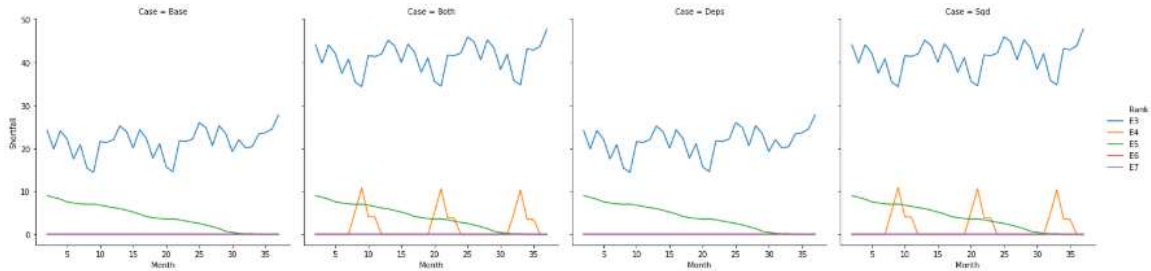

Figure 5.6. Monthly Shortfall by Rank for each Case.

II and IV, there are spikes for “E4”s in the summer months. This is a result of a large number of first-term Marines — typically “E4” at the end of their first-term — leaving service in the summer months at the end of their 4-year contracts.

The largest shortfall occurs with “E3”s and is maintained throughout the experiment for all cases. This shows the majority of the inability of the current manpower to support the force structure — current or proposed — is due to a shortage of “E3” Marines.

Excess

This section summarizes the excess infantry population to understand where more manpower can be re-allocated in order to reduce shortfalls. Table 5.2 shows the total excess for each case across the different components. Case I and II both have larger excesses in the SE while the FMF excesses are similar across all cases. Examining the excesses by rank and

Table 5.2. Total Excess by Component for 36-month Experiment.

Cases	Total	Fleet	SE
Case I: Base	70,565	28,259	42,306
Case II: 15-man Squad	55,943	24,257	31,686
Case III: Deployments	70,663	32,083	38,580
Case IV: Both	55,943	24,257	31,686

MOS provides the best understanding of where promotion and MOS assignment policy can be shifted in order to fill structural shortfalls. Figure 5.7 shows the monthly excess by rank. Notably, all ranks maintain relatively steady excess except for “E4” which exhibits peaks and troughs mirrored to those in Figure 5.6. This represents the high rate of promotion to “E4” — the peaks — prior to a summer EAS — the troughs. These consistent excesses for

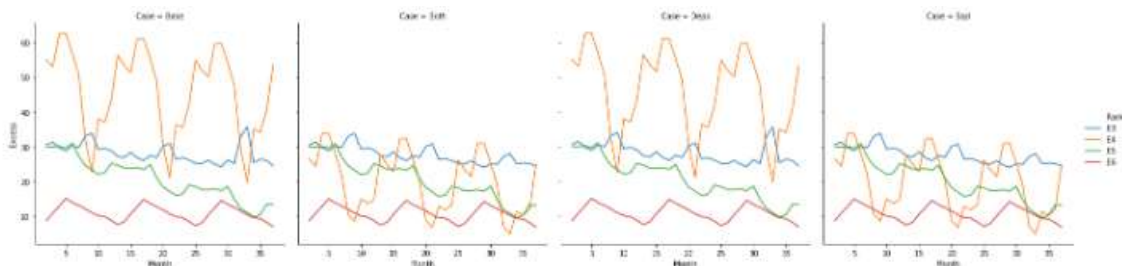

Figure 5.7. Monthly Excess by Rank for each Case.

“E4”’s combined with consistent shortfalls in “E3”’s suggests that the promotion rate from “E3” to “E4” is too high. Slowing the rate will allow more “E3”’s to build in the population, reducing the shortfall of “E3”’s while preventing the excess of “E4”’s.

Figure 5.8 shows the monthly excess by MOS. This plot shows steady excesses in “0331,” “0341,” and “0352” with consistently high, though oscillating, excesses in “0311” and “0369.” The “0311” also exhibits a downward trend to correspond with the downward trend in “0311” shortfalls in Figure 5.5. The consistent excesses in “0331,” “0341,” and “0352” MOSs combined with little to no shortfall — showing no inefficiencies in the assignment process — suggest that these MOSs are over-staffed and a change in the MOS assignment process following ELS graduation can reduce the increased shortfall of “0311”’s caused by switching to a 15-man rifle squad.

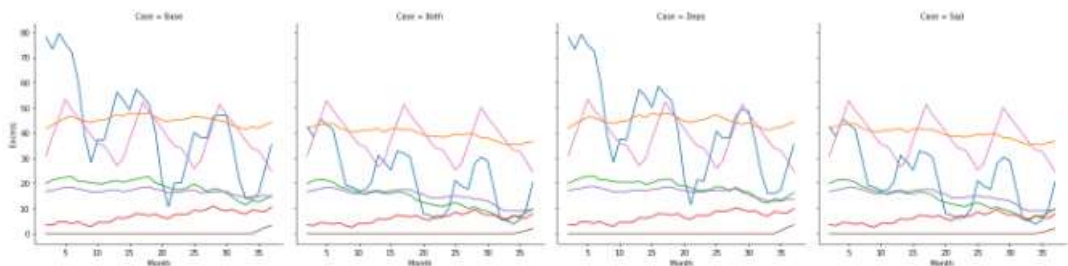

Figure 5.8. Monthly Excess by MOS for each Case.

Conclusion

Experiment 1 showed that neither the current structure or the proposed 15-man rifle squad is supportable by the Marine Corps' infantry population. Additionally, it showed that increasing to a 15-man squad greatly increases the shortfall in deploying units during regimental-sized contingencies.

It did, however, provide insight into where the service can find extra Marines to support the change. The current population and ELS assignment policy has created an excess of "0331," "0341," and "0352" MOSs. Creating fewer of these MOSs in favor of more "0311"s would reduce the shortfall. The current promotion rate to "E4" is also too high. There is a consistent excess of "E4"s but shortfall of "E3"s; reducing the monthly promotion rate would reduce the structural shortfall while saving money in salary.

5.2.2 Experiment 2

Experiment 2 serves to gain a greater understanding of the realistic supportability of policy proposals. This is accomplished by relaxing the rank-MOS billet restrictions in order to allow Marines of one rank higher or one rank lower to fill the billet — known as "one-up, one-down." The model also allows "E5"s, regardless of MOS, to fill "0369" and "0365" billets and "E6"s to fill "0365" billets. By allowing this relaxation, the model more accurately reflects how manpower decisions are made; there is an understanding that the current population does not perfectly match the structure, so allowing Marines to fill billets of similar specialty and experience reduces both excesses and shortfalls.

Figure 5.11 shows the total shortfall and excess within the population for Experiment 2. In contrast to Experiment 1, the shortfall starts low and stays low. There is a large shortfall — though still small relative to Experiment 1 — at the start of the experiment for Cases II and IV, though this is a result of the starting population adjusting to the new 15-man structure. The excess for Experiment 2 is also lower than that of Experiment 1. Most interestingly, all four cases appear to converge to the same shortfall following 24 months while the excess remains lower for Cases II and IV. This suggests that with effective assignment policy the 15-man structure is no worse than the 13-man structure.

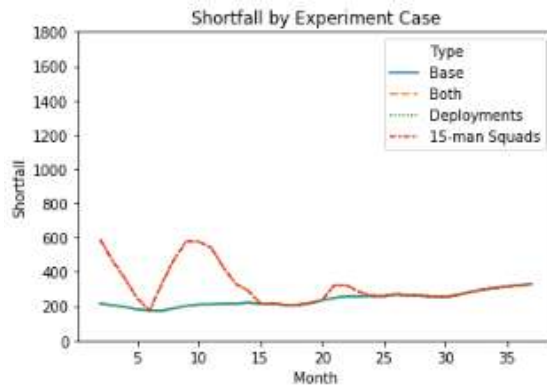

Figure 5.9. Total Shortfall.

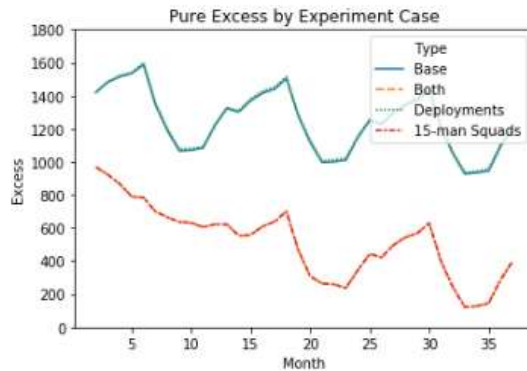

Figure 5.10. Total Excess.

Figure 5.11. The Structural Excess and Shortfall for Experiment 2. There is a Significant Reduction in Both Shortfall and Excess Between Experiments.

Shortfalls

Table 5.3 shows the total shortfall for Experiment 2 and the percentage change for total shortfall versus Experiment 1. Allowing “one-up, one-down” drastically reduces shortfalls across all cases. In particular, Table 5.3 shows a 67% reduction in shortfall for Cases II and IV, the proposed changes.

Table 5.3. Total Shortfall by Component for 36-month Experiment with “One-up, One-down.”

Cases	Total	Fleet	SE	% Difference
Case I: Base	8,588	8,575	13	55%
Case II: 15-man Squad	11,534	11,516	18	67%
Case III: Deployments	8,586	8,489	97	55%
Case IV: Both	11,529	11,413	116	67 %

Although total shortfalls decreased significantly, the most important indicator of policy success is its effect on stabilized FMF units. Figure 5.12 shows the shortfall within stabilize OpFor units for each case. Significantly, the stabilized shortfall for Case IV was reduced by more than 80% between Experiment 1 and 2 — from 5628 to 1107. This equates to approximately 8 Marines per stabilized or deployed unit, a more acceptable risk.

The rank and MOS shortfalls generally follow the same patterns as Experiment 1, though at lower total levels. Figure 5.13 shows the shortfall by rank. Interestingly, the shortfall of “E5”s is greater than that of “E3”s, a significant change.

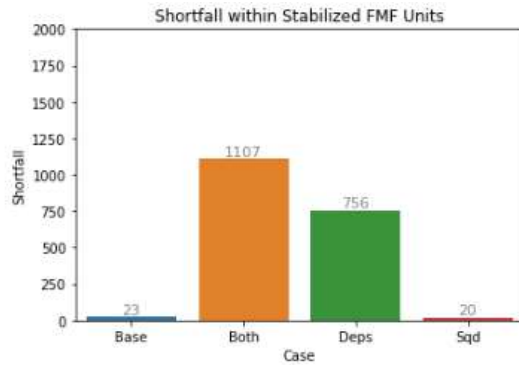

Figure 5.12. Shortfall in Stabilized Units for each Case.

As discussed in Experiment 1, a significant driver of the structural shortfall across the population is the excess promotion of “E3”s to “E4”s. Assuming there are no available “E4” billets at his current unit, the new “E4” will remain in the same billet at the same command fulfilling the “E3” billet requirement and not assuming an PCS cost in order to move to an “E4” billet. “E5” shortfalls are larger than “E3” shortfalls, as many of the units with “E5” shortfalls do not have populations of “E3”s and “E4”s from which to draw support.

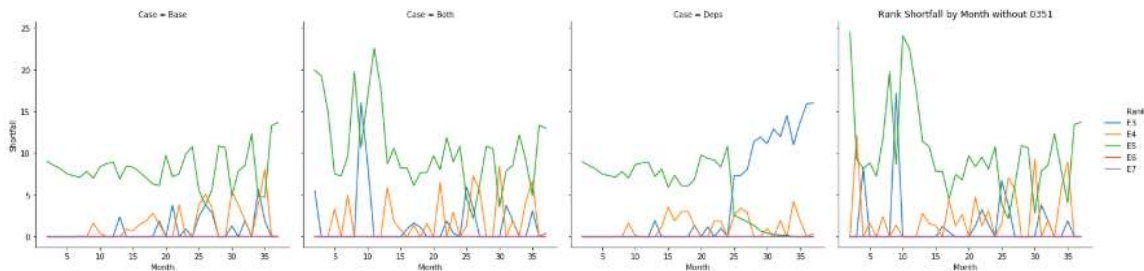

Figure 5.13. Monthly Shortfall by Sank for each Case.

Excesses

The difference between Experiments 1 and 2 is the ability to use excess Marines to fill structure shortfalls left by other ranks and MOSs. Thus, we split the excess variable from the model into two separate groups: commodities where both $prank = brank$ and $pmos = bmos$, and all other commodities.

Figure 5.14 shows that the vast majority of excess which is not able to support other billets in the system is within the “E5” rank. Figure 5.15 shows that this excess is split relatively

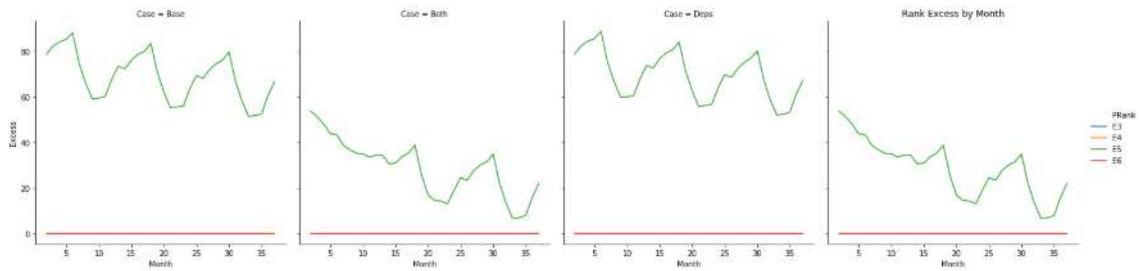

Figure 5.14. Monthly Excess by Rank for each Case.

evenly between all MOSs which “E5”s can hold. This excess is relatively low; however, it does show that the service is retaining more “E5”s than is necessary, an opportunity to shift end strength to other ranks and further reduce shortfalls.

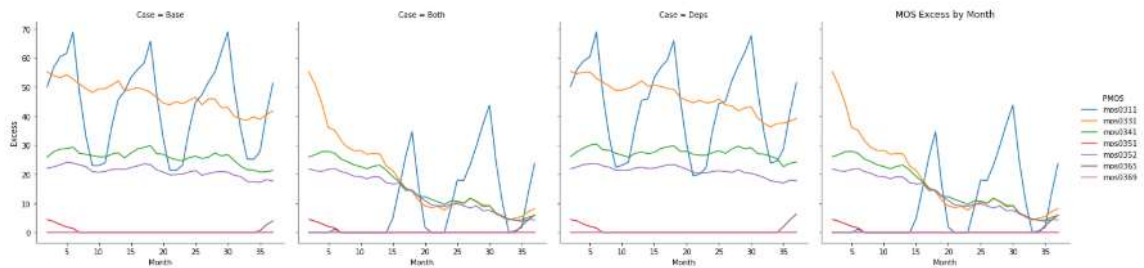

Figure 5.15. Monthly Excess by MOS for each Case.

The more important result from Experiment 2 is which ranks and MOSs are providing support. Figure 5.16 shows that a significant number of billets are filled by Marines of non-billet designated ranks and MOSs. Table 5.4 shows where excess Marines provide

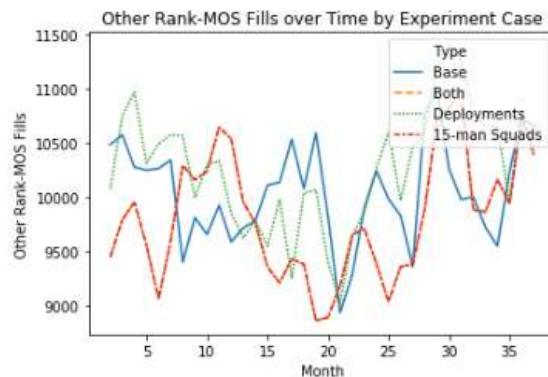

Figure 5.16. Shortfalls Filled by Other Rank-MOS Marines by Month.

support for Case III. The rows represent primary rank and the columns represent billet rank. At first glance, the table appears symmetrical, meaning ranks are providing as much support as they are receiving. However, for all ranks from “E4” to “E6,” more Marines are supporting a billet of lower rank than a billet of higher rank. This is a clear reinforcement of the conclusions from Experiment 1 which found that the promotion rate was too high, and the infantry population had an excess of Marines of higher rank with shortfalls at the junior ranks.

Table 5.4. Where Excess Marines Provide Support for Case III.

	E3	E4	E5	E6	E7
E3	0	81,310	0	0	0
E4	94,900	0	54,804	0	0
E5	0	57,158	18,560	28,463	0
E6	0	0	36,778	0	0
E7	0	0	0	0	6513

Conclusion

Experiment 2 showed that allowing the relaxation of “one-up, one-down” billet assignments resulted in significant improvements to the supportability of the proposed 15-man rifle squad. Most importantly, this practice reduced the shortfall among stabilized units by more than 80%. However, the experiment also reinforced the findings of Experiment 1 in that the infantry population is top-heavy, with too many promotions. By slowing the rate of promotion, the service can more closely match its end strength to its desired force structure.

5.3 Computational Results

The model used in this research consisted of 3.7 million variables and more than 900,000 constraints. Using Pyomo on a 112-core machine, each experiment and case were conducted simultaneously with model build times of approximately 80 minutes and solve times to optimality of approximately 10 minutes (Hart et al. 2017).

The computational results from this network flow model are a significant improvement over previous work done on the subject using mixed integer linear programming. The best prior attempt used a similarly configured machine and took two weeks to find a solution within

27% of optimality. The significant improvements in performance facilitated by the network flow approach will allow quick and accurate analysis of the impact of future force structure changes on force generation.

5.4 Future Work

Although this research provides significant insight into a single proposed change, many opportunities for further study remain.

The next recommended course would be to include Time on Station (TOS) into the commodities within the model. This modification would represent the TOS requirement prior to PCS or PCA, providing more realism in the time required for the population to adapt to new force structures. Including a time component in each commodity would also aid in the realism of promotions and EAS. The current model only considers total quantity promoted and leaving service each month, without taking into account the distribution of eligible Marines across the population.

The second recommended course would be to make the model user-friendly by building an application program interface to manipulate promotion rates, ELS rates, EAS rates, force structure, and deployment schedules. This will greatly reduce data cleaning time, and provide a tool for planners to use in order to assess the viability of policy decisions.

5.5 Conclusion and Recommendations

This research sought to achieve two goals. First, to assess the viability of the currently proposed change from a 13-man to a 15-man rifle squad. Second, to build a model to assess the effects of future force structure changes on the Marine Corps' infantry population.

Under strict interpretation, the current distribution of Marines by rank and MOS cannot support the proposed change to a 15-man rifle squad. The current structure is barely supportable, and the proposed change results in an 82% increase in shortfall across the population with less than a 3% increase in structure. More importantly, when considering a regimental-sized contingency operation, there is a 34% greater shortfall in stabilized units compared to the current structure under the same deployment conditions. The proposed change is intended to increase the combat effectiveness of the Marine Corps; however,

without changing other manpower policies this change will reduce combat effectiveness by increasing manpower shortfalls.

The greatest cause of shortfalls is a top-heavy force. Throughout all situations and MOSs considered, there were excesses of senior Marines with shortfalls of junior Marines. Although the practice of “one-up, one-down” manning mitigates this policy-driven issue, the disparity between the actual population and the population required by the proposed force structure is concerning. Additionally, the addition of two “0311”s per rifle squad greatly increased the shortfalls within this population while the “0331,” “0341,” and “0352” MOSs had consistent excesses.

In order to adapt the force to the proposed structure, the Marine Corps should make two changes. First, it should slow the promotion rate from “E3” to “E4.” There are significant shortfalls in the “E3” population driven primarily by promotion into the already full “E4” population. This leads to both cost and structural inefficiencies in the form of pay increases for Marines to perform the same role. Second, the ELSs should reduce the production of the “0331,” “0341,” and “0352” MOSs in favor of increases in “0311” production. Current proposals suggest the increased “0311” shortfall can be made up by eliminating the “0351” MOS, but that will not provide enough population.

Finally, the Marine Corps should further develop this model to include TOS considerations and an application program interface leverage the speed, efficiency, and detail of the model to supplement the manual work currently done to analyze the effects of force structure policy changes.

THIS PAGE INTENTIONALLY LEFT BLANK

List of References

Annunziata M (2018) *Does the Corps have a “Ready Bench:” An analysis of the disparity between supply and operational demand.* Master’s thesis, Command and Staff College, Marine Corps University, Quantico, VA.

Beindorf L (2018) Data provided by M/RA Enlisted Promotion Plans Officer to the author via email, December 13.

Brown DR G, Wood K (1997) Optimization and Persistence. *Interfaces* 27(5):15–37.

CNA (2019) Data provided to the author via email, January 31.

DC CD and I (2015) Organization of the United States Marine Corps.
<https://www.marines.mil/Portals/59/Publications/MCRP%205-12D.pdf>.

DC, CD and I (2017) Precedence Levels for Manning and Staffing.
<https://www.mccdc.marines.mil/Portals/172/Docs/MCCDC/FDSP/FDS%20References/MCO%205320.12105-01-115230-957>.

DC, M and RA (2014) Personnel Assignment Policy.
<https://www.marines.mil/Portals/59/MCO%201300.8.pdf>.

DC, M/RA (2011) Deployed Unit Cohesion Staffing.
<https://www.marines.mil/News/Messages/Messages-Display/Article/887911/deployed-unit-cohesion-staffing/>.

DC, PP and O (2013) Marine Corps Force Generation Process.
<https://www.marines.mil/News/Publications/MCPEL/Electronic-Library-Display/Article/899465/mco-35026a/>.

DC PP and O (2015) Marine Corps Global Force Management and Force Synchronization. <https://www.marines.mil/Portals/59/Publications/MCO%203120.12.pdf>.

Director, Manpower Plans and Policy (2018) Deployment-to-Dwell Policy. <https://www.marines.mil/News/Messages/Messages-Display/Article/896510/deployment-to-dwell-mobilization-to-dwell-policy-revision/>.

Director, Marine Corps Staff (2015) Total Force Structure Process.
<https://www.marines.mil/Portals/59/MCO%205311.1E%20z.pdf>.

Freeman N (2018) *Improving the Force Generation Process for Marine Corps Infantry Battalions: A Multi-Component Model to Maximize Readiness with Force Synchronization Decisions*. Master's thesis, Department of Operations Research, Naval Postgraduate School, Monterey, CA.

Hart WE, Laird CD, Watson JP, Woodruff DL, Hackebeitl GA, Nicholson BL, Sirola JD (2017) *Pyomo—optimization modeling in python*, volume 67 (Springer Science & Business Media), second edition.

Hooper A, Ostrin G (2012) *Optimizing Marine Corps Personnel Assignments Using an Integer Programming Model*. Master's thesis, Graduate School of Business and Public Policy, Naval Postgraduate School, Monterey, CA.

HQMC (2018) MARINES ANNOUNCE CHANGES TO GROUND COMBAT ELEMENT AIMED AT IMPROVING LETHALITY AND AGILITY <https://www.marines.mil/News/Press-Releases/Press-Release-Display/Article/1516580/marines-announce-changes-to-ground-combat-element-aimed-at-improving-lethality/>.

Jaunal CG (2019) Data provided to the author via email, January 23, 2019.

Larger CR (2019) Data provided to the author from Total Force Data Warehouse via email, January 10, 2019.

Lenstra H (1983) Integer programming with a fixed number of variables. *Mathematics of operations research* 8(8).

MIR (2019) Manpower Information Request for Infantry Separations from January 2006 to December 2018. Accessed January 2019, https://www.manpower.usmc.mil/webcenter/portal/MRAHome/MRA_Apps.

United States Congress (2017) United States Code (U.S.C.), 2012 Edition, Supplement 5, Title 10, Section 5063 - ARMED FORCES. <https://www.govinfo.gov/content/pkg/USCODE-2017-title10/pdf/USCODE-2017-title10-subtitleC-partI-chap507-sec5063.pdf>.

United States Marine Corps (2016) Marine Corps Operating Concept. Technical report, Quantico, VA, <https://www.mccdc.marines.mil/Portals/172/Docs/MCCDC/young/MCCDC-YH/document/final/Marine%20Corps%20Operating%20Concept%20Sept%202016.pdf?ver=2016-09-28-083439-483>.

Van Roy B, Mason K (2008) Chapter 5. Lecture, Introduction to Optimization <https://web.stanford.edu/~ashishg/msande111/notes/chapter5.pdf>.

Initial Distribution List

1. Defense Technical Information Center
Ft. Belvoir, Virginia
2. Dudley Knox Library
Naval Postgraduate School
Monterey, California