



U.S. ARMY COMBAT CAPABILITIES DEVELOPMENT COMMAND – GROUND VEHICLE SYSTEMS CENTER

Combat Vehicle Electrification and Mobility Programs (CVEMP) Key Component Preliminary Requirements

Kevin Boice, Jason Spina, Byron Wong and Jarrod Hoose

DISTRIBUTION A. Approved for public release; distribution unlimited.
OPSEC #:2569



RFI FOR ELECTRIC SPROCKET DRIVE



- An Request For Information was released for an electric sprocket drive to see what industry can offer in support of our platform electrification program
- The electric sprocket drive includes any motor, gearing, and transmission gearing to go from electrical input to sprocket output for the tracks
- The ultimate goal is to commonize the components as much as possible to minimize development costs for both platforms

POC: Kevin Boice (kevin.j.boice.civ@mail.mil)



ELECTRIC SPROCKET DRIVE



The following specs cover the basic needs for the electric sprocket drive and are specified for one side of the vehicle (one sprocket for 15 ton application, one or two sprocket for 50 ton application)

	15 Ton Application	50 Ton Application
Power (continuous, driving)	80kW	260kW
Power (transient, 30 sec. steering)	235kW	900kW
Torque (continuous, driving, high speed)	1000Nm @ 750RPM	2500Nm @ 670RPM
Torque (continuous, driving, low speed, high slope)	4500Nm @ 50RPM	17,000Nm @ 50RPM
Torque (transient, 30 sec. steering)	6600Nm	40,000Nm
Torque (continuous, 0.7 TE/WT)	11,400Nm	42,000Nm
Torque (transient 30 sec., 1.2 TE/WT)	19,500Nm	73,000Nm
Upper Speed	750 RPM	670 RPM
Voltage	600VDC inverter driven	600VDC inverter driven
Coolant Temperature	105°C	105°C
Sprocket Diameter	19.25 inches	21.5 inches
Environmental	ATPD 2404	ATPD 2404



ELECTRIC SPROCKET DRIVE



- **Some examples of ways to achieve the modularity and meet the scaling needs of 15 tons and 50 tons**
 - Paralleling full motors
 - Could parallel motors through a shared shaft, or providing two sprocket drives for a single track side (front and back)
 - Packaging common rotors/stators within the same housing
 - Allowing extension of the machine length to increase power while maintaining the basic rotor / stator structure
- **There is interest in investigating packaging of some or all of the electric sprocket drive motor components within the internal space of the sprocket itself**
- **There is also interest in actively reconfiguring how the motor is wound on the move (delta-Wye, series-parallel, x-poles to 2x poles).**



RFI FOR ENGINE GENERATOR/INVERTER



- Two Requests For Information were released for an engine generator and an inverter to see what industry can offer in support of our platform electrification program
- The generator is for the prime power source on a series hybrid tracked vehicle. The generator will be paired with a diesel engine.
- The generator for the two vehicles (15/50 ton) will be scaled/paralleled versions to reduce development cost. The same inverter would be used for both applications with the plan to parallel them on the larger platform. It would also cover the motors on the platforms.

POC: Kevin Boice (kevin.j.boice.civ@mail.mil)



ENGINE GENERATOR/INVERTER



The following specs cover the basic needs for the diesel electric generator:

	15 Ton Application	50 Ton Application
Power (at generator output)	300-400kW	600-700kW
Voltage (inverter controlled)	600VDC	600VDC
Coolant Temperature	105°C	105°C
Environmental	ATPD 2404	ATPD2404

The generator for the 50 ton application will need to provide two independent outputs. This is because the current vehicle plan is to use the same inverters for the two applications, but the 50 ton application will have two copies of that inverter running in parallel.



ENGINE GENERATOR/INVERTER



- **Some examples of ways to achieve the modularity and meet the scaling needs of 15 tons and 50 tons include:**
 - Paralleling full motors
 - Packaging common rotors/stators within the same housing
 - Allowing extension of the machine length to increase power while maintaining the basic rotor / stator structure.
- **There is also interest in exploring the sizing trades of using gearing sets with high speed generators.**
- **Information on generators alone as well as engine and generator combinations are welcome. Development work on the generators is acceptable, but the engine should be primarily off the shelf.**



ENGINE GENERATOR/INVERTER



The following specs cover the basic needs for the motor / generator inverter:

- **Operate on a 600VDC bus in compliance with MIL-PRF GCS 600A**
- **Power Rating of 400kW continuous, 500 kW for 30 seconds and 600 kW for 5 seconds on the 600VDC bus.**
- **Accept low level control power from a 28VDC bus in compliance with MIL-STD 1275**
- **Support control of the inverter via J1939 compliant CAN**
- **Provide torque, speed, and voltage control modes**
- **Support tuning of control parameters to allow operation with AC as well as internal and surface permanent magnet motors / generators**
- **Support position measurement through a resolver interface**
- **Accept inlet coolant at 105° C**
- **Meet environmental requirements of ATPD2404**

High power density and high temperature will be an important consideration for this application



RFI FOR UNIVERSAL HIGH VOLTAGE CONVERTER (UHVC)



UHVC Purpose:

- The purpose of the UHVC is to provide a controlled interface between the $600V_{DC}$ (MIL-PRF-GCS600A) combat vehicle electrical architecture and electrical sources/loads operating at voltages between $270V_{DC}$ (MIL-STD-704) and $600V_{DC}$ (MIL-PRF-GCS600A)
- The UHVC will be able to bidirectionally control the current flow between the two interfaces regardless of the voltages on those interfaces, allowing these loads and sources to work together in our architecture
- The UHVC will allow the Modular High Voltage Battery to adapt to the $600V_{DC}$ power interface and will allow bidirectional power flow between the two subsystems.

POC: Jason Spina (jason.a.spina.civ@mail.mil)



RFI FOR UNIVERSAL HIGH VOLTAGE CONVERTER (UHVC)



UHVC Details:

- Channel 1 – Flexible Voltage
 - Lower bound 270V_{DC} MIL-STD-704F
 - Upper bound 600V_{DC} MIL-PRF-GCS600A
 - Configurable slew rate (soft start)
 - HVIL is of type source
- Channel 2 –
 - 600V_{DC} MIL-PRF-GCS600A
 - HVIL is of type load as it will be sourced from another device
 - Configurable Pre-charge capability
- Continuous transfer of 120kW
- Non-isolated power transfer
- Power transfer direction and magnitude controlled by CAN
- J1939 Compliant CAN with NCGVEPA Interface Data Description (IDD)
- Control Power 28V_{DC} MIL-STD-1275E
- Operating Temp -40°C to +71°C
- Liquid Cooled, 105°C
- Wide Bandgap based device

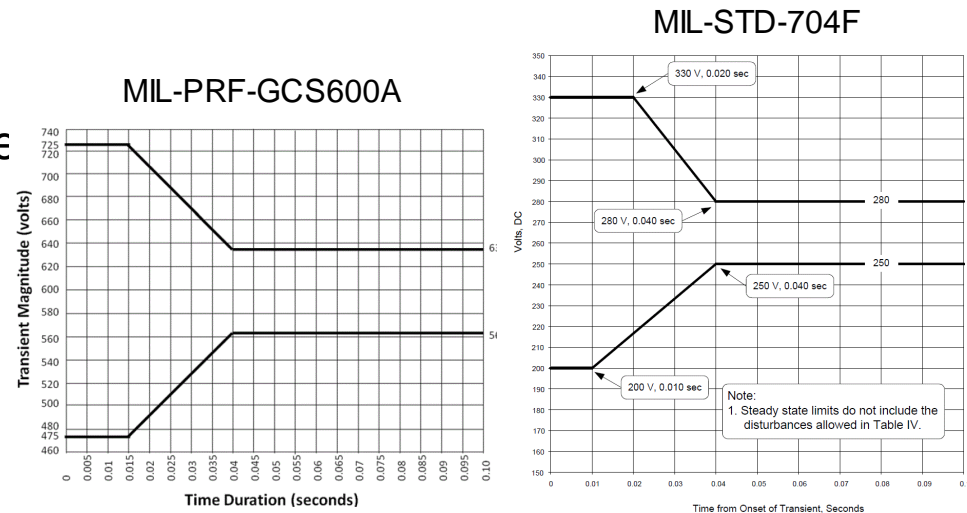
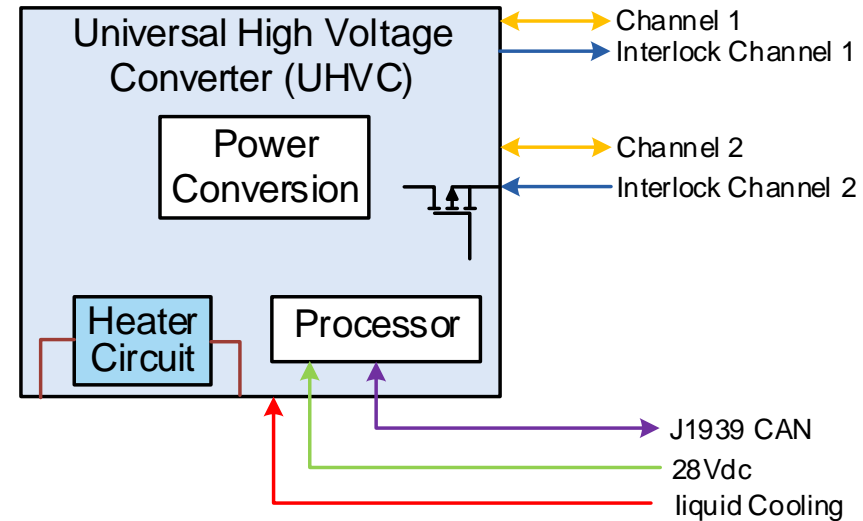



RFI FOR POWERTRAIN HIGH VOLTAGE POWER CONTROLLER (PHVPC)



PHVPC Purpose:

- The purpose of the PHVPC is to safely distribute up to 540kW of 600V_{DC} to 6 bidirectional power channels
- For the 50-ton application
 - 1 channel to Generator Inverter
 - 4 channels to Driver Motor Inverters
 - 1 channel to a High Voltage Power Controller
- For the 15 ton application
 - 1 channel to Generator Inverter
 - 2 channels to Driver Motor Inverters
 - 1 channel to High Voltage Power Controller

POC: Jason Spina (jason.a.spina.civ@mail.mil)



RFI FOR POWERTRAIN HIGH VOLTAGE POWER CONTROLLER (PHVPC)



PHVPC Details:

- 6 MIL-PRF-GCS-600A channels
 - Channel 1: 900A bidirectional
 - Channel 2: 350A bidirectional
 - Channel 3 – 6: 225A bidirectional
- Per Channel safety features:
 - Ground Isolation Fault (GIF) Detection
 - HV Interlock
 - Overcurrent Protection
 - Hardware based fast overcurrent
 - Configurable I2C based overcurrent
 - Arc Flash Mitigation
- Configurable Pre-charge capability for each channel
- Source HVIL power for Channel 1, 3, 4, 5, and 6
- Channel 2 HVIL is a load type as it is sourced from another device
- Control Power 28V_{DC} MIL-STD-1275E
- J1939 Compliant CAN with NCGVEPA Interface Data Description (IDD)
- Operating Temp -40°C to +121°C
- Liquid Cooled, 105°C
- Wide Bandgap based device

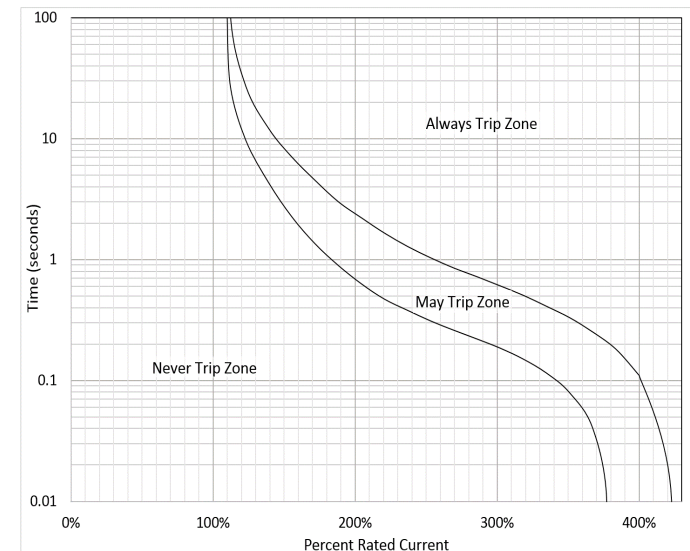
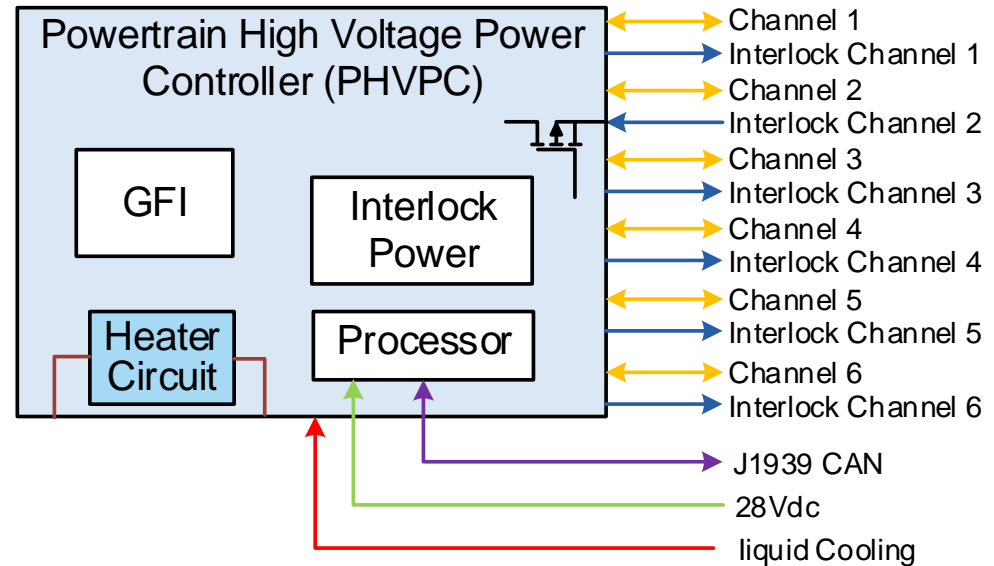



RFI FOR MODULAR HIGH VOLTAGE BATTERY



- An Request For Information was released for an energy storage module to see what industry can offer in support of our platform electrification program
- The energy module will be used as a common building block for high voltage battery packs to be used in two demonstrator platforms
- The ultimate goal is to develop a standardized module that will be used to build future high voltage battery packs

POC: Byron Wong (byron.c.wong2.civ@mail.mil)

https://www.fbo.gov/index?s=opportunity&mode=form&id=ea8338502824aa8f0a126cb7cde9661f&tab=core&_cview=0



HIGH VOLTAGE BATTERY MODULE



Key Features of Module:

- Voltage: 24 – 60 V
 - Energy: 1.5 – 4 kWh
 - Volume: 10 – 25 liters
 - Weight: less than 60 kg
 - Peak Power: 20 – 25 kW
-
- Scalable modules that connected in series/parallel to meet energy storage needs of electrified platforms.
 - Thermal management to enable operation at continuous 5 to 10 C-rate
 - Continuous operation at temperatures -30°C to 60°C
 - Envision qualification to occur at the module level.

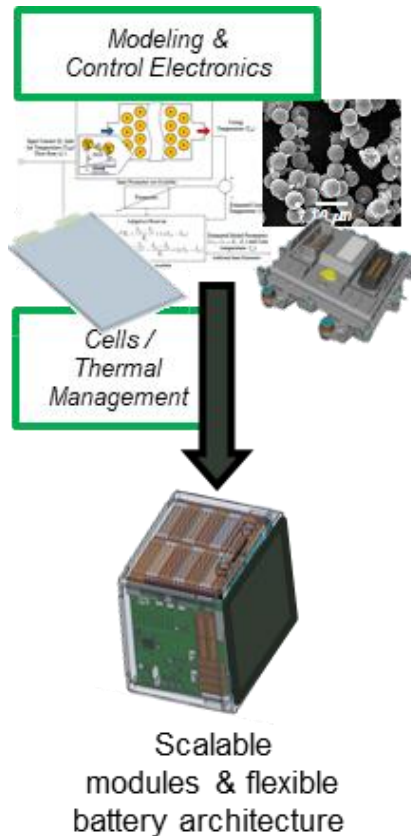

Applications:

- Hybrid applications
 - Ground Vehicles
 - AF Support Vehicles
 - Shipboard UPS/Pulse Power

POC: Byron Wong (byron.c.wong2.civ@mail.mil)

https://www.fbo.gov/index?s=opportunity&mode=form&id=ea8338502824aa8f0a126cb7cde9661f&tab=core&_cview=0



MODULE / PACK BATTERY MANAGEMENT SYSTEM



- **Module level BMS**
 - BMS at the module level that provides status and monitoring information for safe operation of the pack, built-in tests, diagnostics, and module cell balancing
 - Digital communication on the module (ISO 11898 CAN, SPI)
- **Pack level BMS**
 - Receives monitoring information from the module BMS
 - Coordinates module cell balancing
 - Reports battery pack status and monitoring information on the vehicle digital communications buses
 - Built-in tests & diagnostics
 - Controls battery thermal management, battery protection devices, and pre-charge/main contactors.
- **The BMS architecture shall provide protection to the user during normal vehicle operation and maintenance activities.**

POC: Byron Wong (byron.c.wong2.civ@mail.mil)

https://www.fbo.gov/index?s=opportunity&mode=form&id=ea8338502824aa8f0a126cb7cde9661f&tab=core&_cview=0



NOTIONAL HIGH VOLTAGE PACK

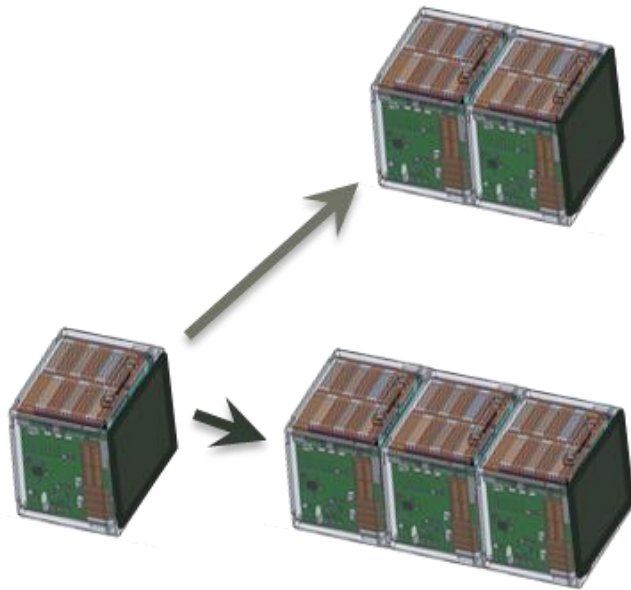

- Nominal Voltage from 450 to 600 V
- Continuous power capability of 250 to 400 kW
- 25 to 100 kWh installed energy
- Rechargeable from 0% to 90% SOC within thirty minutes.
- Full operational capabilities between -30°C to 60°C with thermal management
- Diminished operational capabilities down to -46°C or up to 71°C, or without thermal management.
- A minimum of two (2) SAE J1939 interfaces for vehicle communication

POC: Byron Wong (byron.c.wong2.civ@mail.mil)

https://www.fbo.gov/index?s=opportunity&mode=form&id=ea8338502824aa8f0a126cb7cde9661f&tab=core&_cview=0



RFI FOR HYDROGEN FUEL CELL



- A Request For Information was released for a 400 kWe hydrogen fuel cell to see what industry can offer in support of our platform electrification program
 - Commercial automotive industry, has invested billions of dollars in fuel cell technology development and GM, Toyota, Honda and Hyundai all have fuel cell passenger vehicles for sale.
 - Heavy duty trucking (Nikola, Toyota-Kenworth) has started to invest in fuel cell based Class 8 trucks. This pushes power levels closer to military requirements.
- The fuel cell will be used in a hybrid configuration with a high voltage battery pack to power an electrified demonstrator platform
- The goal is to develop a multi-stack fuel cell that meets the 400 kWe net output power level that is scalable for smaller or larger vehicle applications

POC: Kari Drotleff (kari.a.drotleff.civ@mail.mil)



RFI FOR HYDROGEN FUEL CELL



Key Features of fuel cell:

- Net Power Output: 400 kWe
- Voltage Output: 300 V
- Stack Volume: 87 ft³

- Scalable fuel cell stacks that meet power needs of electrified platform

- System includes all balance of plant components (powered by gross power output of fuel cell)

- System includes all required thermal management components for a stand-alone system (not included in stack volume space claim)

- System includes all internal controls for operation and safety
 - Reports fuel cell status and monitoring information on the vehicle digital communications buses
 - Incorporates built-in tests & diagnostics

- Continuous operation at temperatures -30°C to 60°C

POC: Kari Drotleff (kari.a.drotleff.civ@mail.mil)