

NFESC
TECH INFO CTR (CODE ESC 122)
560 CENTER DRIVE
PORT HUENEME, CA 93043-4328

PB90-187196
EPA/600/3-90/012
February 1990

EXPERT SYSTEM FOR HYDRODYNAMIC MIXING ZONE
ANALYSIS OF CONVENTIONAL AND TOXIC SUBMERGED
SINGLE PORT DISCHARGES (CORMIX1)

by

Robert L. Doneker and Gerhard H. Jirka

DeFrees Hydraulics Laboratory
School of Civil and Environmental Engineering
Cornell University
Ithaca, New York 14853

Cooperative Agreement No. CR813093

Project Officer:

Thomas O. Barnwell, Jr.
Assessment Branch
Environmental Research Laboratory
Athens, Georgia

ENVIRONMENTAL RESEARCH LABORATORY
OFFICE OF RESEARCH AND DEVELOPMENT
U.S. ENVIRONMENTAL PROTECTION AGENCY
ATHENS, GEORGIA 30613

REPRODUCED BY
U.S. DEPARTMENT OF COMMERCE
NATIONAL TECHNICAL INFORMATION SERVICE
SPRINGFIELD, VA. 22161

TECHNICAL REPORT DATA

(Please read Instructions on the reverse before completing)

1. REPORT NO. EPA/600/3-90/012		2.	3. RECIPIENT'S ACCESSION NO. PB 90 187196 JAS	
4. TITLE AND SUBTITLE EXPERT SYSTEM FOR HYDRODYNAMIC MIXING ZONE ANALYSIS OF CONVENTIONAL AND TOXIC SUBMERGED SINGLE PORT DISCHARGES (CORMIX1)			5. REPORT DATE February 1990	
7. AUTHOR(S) Robert L. Doneker and Gerhard H. Jirka			6. PERFORMING ORGANIZATION CODE	
9. PERFORMING ORGANIZATION NAME AND ADDRESS Defrees Hydraulics Laboratory School of Civil and Environmental Engineering Cornell University Ithaca NY 14853			8. PERFORMING ORGANIZATION REPORT NO.	
12. SPONSORING AGENCY NAME AND ADDRESS Environmental Research Laboratory - Athens, GA Office of Research and Development U.S. Environmental Protection Agency Athens GA 30613			10. PROGRAM ELEMENT NO. ANWB1E	
			11. CONTRACT/GRANT NO. CR813093	
			13. TYPE OF REPORT AND PERIOD COVERED	
			14. SPONSORING AGENCY CODE EPA/600/01	
15. SUPPLEMENTARY NOTES				
16. ABSTRACT U.S. water quality policy includes the concept of a mixing zone, a limited area or volume of water where the initial dilution of a discharge occurs. The Cornell Mixing Zone Expert System (CORMIX1) was developed to predict the dilution and trajectory of a submerged single port discharge of arbitrary density (positive, neutral, or negative) into a stratified or uniform density ambient environment with or without crossflow. CORMIX1 uses knowledge and inference rules based on hydrodynamic expertise to classify and predict buoyant jet missing. CORMIX1 gathers the necessary data, checks for data consistency, assembles and executes the appropriate hydrodynamic simulation models, interprets the results of the simulation in terms of the legal requirements including toxic discharge criteria, and suggests design alternatives to improve dilution characteristics. The model, with its emphasis on rapid initial mixing, assumes a conservative pollutant discharge neglecting any physical, chemical, or biological reaction or decay process. The predictive results can be readily converted, however, to adjust for first-order reaction processes. The results of the hydrodynamic simulation are in good agreement with field and laboratory data. In particular, CORMIX1 correctly predicts highly complex discharge situations involving boundary interactions, dynamic bottom attachments, internal layer formation, and buoyant intrusions.				
17. KEY WORDS AND DOCUMENT ANALYSIS				
a. DESCRIPTORS		b. IDENTIFIERS/OPEN ENDED TERMS		c. COSATI Field/Group
18. DISTRIBUTION STATEMENT RELEASE TO PUBLIC		19. SECURITY CLASS (This Report) UNCLASSIFIED		21. NO. OF PAGES
		20. SECURITY CLASS (This page) UNCLASSIFIED		22. PRICE

DISCLAIMER

The information in this document has been funded wholly or in part by the United States Environmental Protection Agency under Cooperative Agreement Number CR813093 to Cornell University. It has been subjected to the Agency's peer and administrative review, and it has been approved for publication as an EPA document.

FOREWORD

As environmental controls become more costly to implement and the penalties of judgment errors become more severe, environmental quality management requires more efficient management tools based on greater knowledge of the environmental phenomena to be managed. As part of this Laboratory's research on the occurrence, movement, transformation, impact, and control of environmental contaminants, the Assessment Branch develops state-of-the-art mathematical models for use in water quality evaluation and management.

Special water quality regulations have been proposed to limit lethal acute concentrations of toxic pollutants to a spatially restricted toxic dilution zone. Predictive mathematical models are used to establish the initial dilution of a given discharge and the characteristics of its mixing zone. To assist the analyst in choosing the appropriate models, determining the limits of applicability, and establishing data needs, an expert system has been developed. The structured computer program uses knowledge and inference procedures that would be used by water quality experts. Operated on a personal computer, the program appears to be a highly flexible tool for regulatory analysis that is adaptable to the evaluation of alternatives in engineering design.

Rosemarie C. Russo, Ph.D.
Director
Environmental Research Laboratory
Athens, Georgia

ABSTRACT

U.S. water quality policy includes the concept of a mixing zone, a limited area or volume of water where the initial dilution of a discharge occurs. Water quality standards apply at the edge and outside the mixing zone. The implementation of this policy in the permitting process places the burden of prediction of initial dilution on both regulators and dischargers. Dischargers of aqueous toxic substances are subject to additional mixing zone requirements. Give a myriad of possible discharge configurations, ambient environments, and mixing zone definitions, the analyst needs considerable training and expertise to conduct accurate and reliable mixing zone analysis.

The Cornell Mixing Zone Expert System (CORMIX1) was developed to predict the dilution and trajectory of a submerged single port discharge of arbitrary density (positive, neutral, or negative) into a stratified or uniform density ambient environment with or without crossflow. CORMIX1 uses knowledge and inference rules based on hydrodynamic expertise to classify and predict buoyant jet mixing. CORMIX1 gathers the necessary data, checks for data consistency, assembles and executes the appropriate hydrodynamic models, interprets the results of the simulation in terms of the legal requirements including toxic discharge criteria, and suggests design alternatives to improve dilution characteristics.

CORMIX1, with its emphasis on rapid initial mixing, assumes a conservative pollutant discharge neglecting any physical, chemical, or biological reaction or decay process. The predictive results can be readily converted, however, to adjust for first-order reaction processes.

The results of the hydrodynamic simulations are in good to excellent agreement with field and laboratory data. In particular, CORMIX1 correctly predicts highly complex discharge situations involving boundary interactions, dynamic bottom attachments, internal layer formation, and buoyant intrusions--all features that are beyond the predictive capabilities of other currently available initial mixing models.

This report was submitted in partial fulfillment of Cooperative Agreement No. CR813093 with Cornell University under the sponsorship of the U.S. Environmental Protection Agency. This report covers a period from July 1986 to July 1989, and work was completed as of July 1989.

CONTENTS

Abstract	iv
Acknowledgments	xv

Chapter I

INTRODUCTION AND LEGAL BACKGROUND	1
1.1 Introduction	1
1.2 Overview of U.S. Water Quality Policy	2
1.2.1 The Federal Water Pollution Control Act of 1972	4
1.2.2 The Clean Water Act of 1977	6
1.3 The Concept of Mixing Zones	9
1.3.1 Mixing Zones: Development and Regulations	9
1.3.2 Special Mixing Zone Requirements for Toxic Substances	13
1.4 Regulatory Assessment of Discharges and the Permitting Process	14
1.4.1 The NPDES Permit System	14
1.4.2 Need for Regulatory Assessment Tools	14
1.4.3 Motivation for Expert Systems Approach	15
1.5 CORMIX1: An Expert System for Mixing Zone Analysis of Submerged Single Port Aquatic Discharges	18
1.5.1 Scope and Objective	18
1.5.2 Results of an Earlier Feasibility Study	19
1.5.3 Summary of Present Study	19

Chapter II

HYDRODYNAMIC ELEMENTS OF MIXING PROCESSES	21
2.1. Buoyant Jet Mixing Processes	23
2.1.1 Description of Turbulent Jets and Plumes	23
2.1.2 Dimensional Analysis of Buoyant Jets	24
2.1.2.1 Simple Jet in Stagnant Uniform Environment	25
2.1.2.2 Simple Plume in Stagnant Uniform Environment	27
2.1.2.3 Generalizations: Jet/Plume Interactions, Crossflow Effects, and Stratification Effects	29
2.1.3 Length Scales	32
2.1.3.1 Discharge Length Scale	32
2.1.3.2 Jet/Crossflow Length Scale	32
2.1.3.3 Plume/Crossflow Length Scale	33

2.1.3.4 Jet/Plume Length Scale	33
2.1.3.5 Jet/Stratification Length Scale	33
2.1.3.6 Plume/Stratification Length Scale	34
2.1.4 Typical Flow Regimes of Unconfined Buoyant Jets	34
2.1.4.1 Weakly Deflected Jet In Crossflow	35
2.1.4.2 Strongly Deflected Jet In Crossflow	36
2.1.4.3 Weakly Deflected Plume in Crossflow	37
2.1.4.4 Strongly Deflected Plume in Crossflow	37
2.1.4.5 Horizontal Jet with Vertical Buoyant Deflection	38
2.1.4.6 Vertical Plume with Horizontal Momentum Deflection	39
2.2.4.7 Vertical Jet in Linear Stratification	40
2.2 Buoyant Spreading Processes	41
2.2.1 Buoyant Surface Spreading	41
2.2.2 Buoyant Bottom Spreading	44
2.2.3 Buoyant Spreading at Pycnocline	44
2.2.4 Buoyant Spreading at Terminal Level	44
2.3 Passive Ambient Diffusion Processes	46
2.3.1 Diffusion in Unbounded Channel Flow	46
2.3.2 Horizontal Diffusion in Unbounded Channel Flow	48
2.3.3 Vertical Diffusion in Stratified Shear Flow	49
2.4 Interaction Processes: Surface or Bottom Boundaries, and Internal Layer Formation	49
2.4.1 Near-Horizontal Surface Approach	50
2.4.2 Near-Vertical Surface Impingement with Buoyant Upstream Spreading	54
2.4.3 Near-Vertical Surface Impingement with Full Vertical Mixing	57
2.4.4 Bottom Interaction Processes	57
2.4.4.1 Wake Attachment	58
2.4.4.2 Coanda Attachment	60

Chapter III

HYDRODYNAMIC FLOW CLASSIFICATION	61
3.1 Ambient and Discharge Data: Geometry and Flow Variables	61
3.1.1 Ambient Geometry and Flow Conditions	61
3.1.2 Ambient Density Stratification	62
3.1.3 Discharge Parameters	64
3.2 Near-field Flow Classification	66
3.2.1 General Procedure	68
3.2.2 Flow Classes S for Linear Ambient Stratification	75
3.2.3 Flow Classes V or H for Buoyant Discharges into Uniform Ambient Layers	76
3.2.4 Flow Classes NV or NH for Negatively Buoyant Discharges in Uniform Ambient Layers	77
3.2.5 Flow Classes (..)A for Bottom Attached	

Flows	78
3.3 Far-Field Flow Behavior	79

Chapter IV

EXPERT SYSTEM CORMIX1: GENERAL FRAMEWORK	81
4.1 Background on Expert Systems and Logic Programming	82
4.2 Structure of CORMIX1	85
4.2.1 Data Input Element: DATIN	85
4.2.2 Parameter Computation Element: PARAM	89
4.2.3 Flow Classification Element: CLASS	89
4.2.4 Hydrodynamic Simulation Element: HYDRO	91
4.2.5 Hydrodynamic Simulation Summary Element: SUM	91

Chapter V

CORMIX1: FLOW PROTOCOLS AND SIMULATION MODULES	93
5.1 Flow Protocols	93
5.1.1 Flow Protocols for Buoyant Discharges into Uniform Ambient Layers (Flow Classes V and H)	96
5.1.2 Flow Protocols for Negatively Buoyant Discharges into Uniform Ambient Layers (Flow Classes NV and NH)	101
5.1.3 Flow Protocols for Discharges Trapped in Linearly Stratified Ambients (Flow Class S)	101
5.1.4 Flow Protocols for Bottom Attached Flows (Flow Classes (..)A)	107
5.2 Hydrodynamic Simulation Modules	107
5.2.1 Simulation Modules for Buoyant Jet Near-Field Flows	110
5.2.1.1 Introductory Comments	110
5.2.1.1 Discharge Module (MOD01)	111
5.2.1.2 Weakly Deflected Jet In Crossflow (MOD11, mdnf)	112
5.2.1.3 Weakly Deflected Wall Jet in Crossflow (MOD12, mdnf-wj)	113
5.2.1.4 Near-Vertical Jet in Linear Stratification (MOD13, mdls-v)	113
5.2.1.5 Near-Horizontal Jet in Linear Stratification (MOD14, mdls-h)	114
5.2.1.6 Strongly Deflected Jet In Crossflow (MOD16, mdff)	114
5.2.1.8 Strongly Deflected Wall Jet in Crossflow (MOD17, mdff-wj)	115
5.2.1.4 Weakly Deflected Plume in Crossflow (MOD21, bdnf)	115
5.2.1.9 Strongly Deflected Plume in Crossflow (MOD22, bdff)	115
5.2.2 Simulation Modules for Boundary Interaction	

Processes	116
5.2.2.1 Near-Horizontal Surface/Bottom/Pycnocline Approach (MOD31)	116
5.2.2.2 Near-Vertical Surface/Bottom/Pycnocline Impingement with Buoyant Upstream Spreading (MOD32)	117
5.2.2.3 Near-Vertical Surface/Bottom/Pycnocline Impingement with Full Vertical Mixing (MOD33)	118
5.2.2.4 Near-Vertical Surface/Bottom/Pycnocline Impingement with Unstable Recirculation, Buoyant Restratification, and Upstream Spreading (MOD34)	118
5.2.2.5 Stratified Terminal Layer Impingement with Buoyant Upstream Spreading (MOD36)	118
5.2.2.6 Stratified Near-Vertical Surface Injection with Upstream Spreading (MOD37)	119
5.2.3 Simulation Modules for Buoyant Spreading Processes	119
5.2.3.1 Buoyant Surface/Bottom Spreading (MOD41)	119
5.2.3.2 Buoyant Terminal Layer Spreading (MOD42)	120
5.2.4 Simulation Modules for Attachment/Detachment Processes	120
5.2.4.1 Wake Recirculation (MOD51)	120
5.2.4.1 Lift-Off/Fall-Down (MOD52)	120
5.2.5 Simulation Modules for Ambient Diffusion Processes	120
5.2.5.1 Passive Diffusion in Uniform Ambient (MOD61)	121
5.3.5.4 Passive Diffusion in Stratified Ambient (MOD62)	121
5.3 Transition Rules, Flow Criteria and Coefficient Values	121
5.3.1 Transition Rules	122
5.3.2 Flow Classification Criteria	122
5.3.3 Terminal Layer Expressions	128
5.3.4 Model Coefficient Values	128

Chapter VI

SYSTEM EVALUATION AND VERIFICATION	133
6.1 Buoyant Jets in Unconfined Ambient	134
6.1.1 Comparison With Experimental Data	134
6.1.1.1 Stagnant Ambient	134
6.1.1.2 Flowing Unstratified Ambient	137
6.1.1.2.1 Pure Jets In Crossflow	137
6.1.1.2.2 Buoyant Jets in Crossflow	141
6.1.1.2.3 Negatively Buoyant Jets in Crossflow	141
6.1.1.2.4 Buoyant Jets with Three-Dimensional Trajectories	141
6.1.1.3 Buoyant Jet in Stratified Stagnant Ambient	147
6.1.2 Comparison of Predictions With Jet Integral Models	150

6.1.2.1 Buoyant Jet in Uniform Crossflow	150
6.1.2.2 Buoyant Jet in Stratified Crossflow	150
6.2 Complex Flows With Boundary Interaction	153
6.2.1 Jet Flows in Shallow Receiving Waters	153
6.2.2 Strongly Buoyant Jets in Shallow Receiving Waters	153
6.2.3 Flows with Wake Interaction	156
6.2.4 Negatively Buoyant Flows With Upstream Spreading Along Bottom	158
6.3 Summary and Appraisal	158

Chapter VII

APPLICATIONS OF CORMIX1	161
7.1 AB Chemical Corporation	161
7.1.1 The Problem Statement	161
7.1.2 CORMIX1 Analysis	162
7.2 MN Municipal Treatment Plant	169
7.2.1 The Problem Statement	169
7.2.2 CORMIX1 Analysis	169
7.3 PQ Power Company	174
7.2.1 The Problem Statement	174
7.3.2 CORMIX1 Analysis	176
7.4 Comments on the Application of CORMIX1	179
7.4.1 Limitations of CORMIX1	179
7.4.2 Hints for CORMIX1 Use in Extreme Conditions	181
7.4.2.1 (Near-)Surface Discharges	181
7.4.2.2 Elevated Discharges	182
7.4.3 Application to Non-Dimensional Coordinate Systems	182
7.4.4 Adaptation to First-Order Reaction Processes	183

Chapter VIII

CONCLUSIONS AND RECOMMENDATIONS	184
REFERENCES	186

Appendix A

STABILITY OF STRATIFIED AMBIENT SHEAR FLOWS	192
--	-----

Appendix B

ON-LINE USER ADVICE FOR DATA INPUT (DATIN)	194
B.1 Introductory Advice	194

B.2 Ambient Advice	196
B.3 Density Profile Advice	199
B.4 Discharge Advice	199
B.5 Mixing Zone Advice	200
B.6 Design Advice	201

APPENDIX C

FLOW CLASSIFICATION DESCRIPTIONS	204
C.1 V-Flow Classes	204
C.2 H-Flow Classes	210
C.3 S-Flow Classes	217
C.4 NV-Flow Classes	222
C.5 NH-Flow Classes	228
C.6 Attached Flow Classes	233

Appendix D

HYDRO OUTPUT FILE EXAMPLE	238
-------------------------------------	-----

Appendix E

CASE SUMMARY AND DESIGN RECOMMENDATION EXAMPLE	244
---	-----

List of Tables

Table 1.1 Key Federal Water Pollution Control Laws	3
Table 1.2 Examples of Conventional, Nonconventional, and Toxic Pollutants	7
Table 1.3 Examples of Technology-Based Effluent Limitations Under The Clean Water Act of 1977	8
Table 1.4 State Legal Mixing Zones	11
Table 3.1 Flow Classification Variables and Length Scales	67
Table 3.2 Near-Field Flow Classification Procedure	73
Table 4.1 CORMIX1 Program File Directories	87
Table 5.1 Flow Prediction Modules of CORMIX1	94
Table 5.2 Flow Protocols for Buoyant Discharges into Uniform Ambient Layers	98
Table 5.3 Flow Protocols for Negatively Buoyant Discharges into Uniform Ambient Layers	102
Table 5.4 Flow Protocols for Discharges Trapped in Linearly Stratified Ambients	105
Table 5.5 Flow Protocols for Bottom Attached Flows	108
Table 5.6 Transition Rules	123
Table 5.7 Coefficients Used in Transition Rules	125
Table 5.8 Flow Classification Criteria	126
Table 5.9 Stratified Terminal Height Expressions	129
Table 5.10 Module Constants	130

List of Figures

Figure 2.1 Illustrative Near-Field and Far-Field Regions of Submerged Positively Buoyant Discharge	22
Figure 2.2 Pure Jet in Stagnant Environment	26
Figure 2.3 Simple Plume in Stagnant Environment	28
Figure 2.4 Examples of Combined Effects of Momentum Flux, Buoyancy Flux, Crossflow, and Density Stratification on Flow Behavior	30
Figure 2.5 Buoyant Surface Spreading Process	42
Figure 2.6 Density Perturbation of Ambient Stratification Leading to Buoyant Spreading Processes	45
Figure 2.7 Passive Ambient Diffusion Process	47
Figure 2.8 Flow Interaction Process with Water Surface	51
Figure 2.9 Near-Field Attachment Processes	59
Figure 3.1 Definition Diagram for Single Port Discharge Geometry in Ambient Channel with rectangular Cross-Section	63
Figure 3.2 Representative Stable Density Profiles (Four Stratification Types)	65
Figure 3.3 Sub-Classification: Assessment of Ambient Density Stratification and Different Flow Classes for Internally Trapped Discharges	69
Figure 3.4 Sub-Classification: Behavior of Positively Buoyant Discharges in Uniform Ambient Layer	70
Figure 3.5 Sub-Classification: Behavior of Negatively Buoyant Discharges in Uniform Ambient Layer	71
Figure 3.6 Sub-Classification: Dynamic Bottom Attachment of Discharge Due to Wake or Coanda Effects	72
Figure 4.1 System Elements of CORMIX1	86
Figure 5.1 General Behavior for Buoyant Jet in Unconfined and Unstratified Crossflow	97

Figure 6.1 Horizontal Buoyant Jet Trajectory in Stagnant Ambient	135
Figure 6.2 Horizontal Buoyant Jet Trajectories in Stagnant Ambient Over a Range of Froude Numbers	136
Figure 6.3 Horizontal Buoyant Jet Dilution in Stagnant Ambient	138
Figure 6.4 Non-buoyant Jet Trajectory in Uniform Crossflow	139
Figure 6.5 Non-Buoyant Jets at Various Discharge Angles in Uniform Crossflow	140
Figure 6.6 Buoyant Jet Discharging Vertically into Weak Crossflow	142
Figure 6.7 Buoyant Jet Discharging Vertically into Strong Crossflow	143
Figure 6.8 Buoyant Jet Discharged Vertically into Weak Crossflow (Logarithmic presentation)	144
Figure 6.9 Negatively Buoyant Jet Discharging Obliquely Upward in Uniform Crossflow	145
Figure 6.10 Three-Dimensional Trajectory of Transverse Horizontal Buoyant Jet in Weak Crossflow	146
Figure 6.11 Three-Dimensional Trajectory of Transverse Horizontal Buoyant Jet in Strong Crossflow	148
Figure 6.12 Buoyant Jet Trajectories in Stratified Stagnant Ambient	149
Figure 6.13 Comparison of CORMIX1 Predictions with Integral Buoyant Jet Models in Uniform Crossflow	151
Figure 6.14 Comparison of CORMIX1 Predictions with Integral Buoyant Jet Models in Stratified Crossflow	152
Figure 6.16 Cooling Water Outfall from San Onofre Nuclear Power Plant (Unit 1)	154
Figure 6.17 Strongly Buoyant Plume in Crossflow	155
Figure 6.18 Interaction of Negatively Buoyant Jet with Bottom Boundary	159

Figure 7.1	AB Chemical Company: Schematization of Cross-Section at the Discharge Site	163
Figure 7.2	AB Chemical Co. Design Case No. 1: Predictions (bottom attached jet)	165
Figure 7.3	AB Chemical Co. Design Case No. 2: Close-up View of Unattached Buoyant Jet Near Discharge	167
Figure 7.4	AB Chemical Co. Design Case No. 2: Overall Appearance of Discharge Plume	168
Figure 7.5	MN Treatment Plant: Typical Density Profiles for Summer and Winter Conditions	170
Figure 7.6	MN Treatment Plant Summer Design Case: Internal Flow Trapping Caused by Pycnocline Density Jump	172
Figure 7.7	MN Treatment Plant Summer Design Case: Far-Field Behavior of Internally Trapped Flow	173
Figure 7.8	MN Treatment Plant Winter Design Case: Plume Surface Interaction	175
Figure 7.9	PQ Cooling Water Outfall in Low Current Design Case: Near-Field Plume Behavior	177
Figure 7.10	PQ Cooling Water Outfall High Current Design Case: Near-Field Plume Behavior	178
Figure 7.11	Parameter Range of CORMIX1 Applicability	180

Acknowledgments

This study was conducted at the DeFrees Hydraulics Laboratory, Cornell University, in cooperation with the United States Environmental Protection Agency, Environmental Research Laboratory, Athens, Georgia. The authors want to extend their appreciation to Dr. Thomas O. Barnwell, Jr., project officer, who provided the initial stimulus for the project and further guidance throughout the study.

The authors acknowledge the assistance given by Dr. Anil Nerode, Director of the Mathematical Sciences Institute at Cornell University, in the development of expert system structure and logic elements. Professor Douglas A. Haith, Department of Agricultural Engineering, Cornell University, provided valuable review and criticism. Mr. Paul Akar, Graduate Research Assistant at Cornell University, was instrumental for the timely completion of the project through evaluation of the computer code and knowledge base and the execution of numerous test cases. Mr. Gilbert Jones, Graduate Research Assistant, assisted in final report preparation and system evaluation.

The work was carried out using the computer facilities of the DeFrees Hydraulics Laboratory. Mr. Cameron Willkens, Electronics Technician, generously assisted with solutions for computer hardware and software problems.

This report was submitted with essentially similar contents by Robert L. Doneker, Graduate Research Assistant, to the Graduate School of Cornell University in partial fulfillment of the requirements for the degree of Doctor of Philosophy. Dr. Gerhard H. Jirka, Professor of Civil and Environmental Engineering, was project supervisor.

Chapter I

Introduction and Legal Background

1.1 Introduction

Consider the numerous liquid waste streams emanating from industrial, municipal, agricultural, and domestic activities that are routinely discharged into water bodies. The size and flow characteristics of receiving water bodies vary widely -- they may be small streams, large rivers, reservoirs, estuaries, or coastal waters. The water body may be deep or shallow, stagnant or flowing, and may exhibit ambient density stratification of various degree. Also, the discharge type and configuration can be highly variable. The flow may contain pollutants ranging from conventional to toxic substances, vary greatly in magnitude ranging from low flowrates for a small sewage treatment plant to the substantial cooling water flows for a large stream-electric power plant, issue with high or low velocity, be denser or lighter than the ambient, be located near shore or far offshore, and exhibit various geometric details ranging from single port submerged discharges to multiport submerged diffusers to surface discharges.

Given this diversity of both discharge and ambient environmental conditions, a large number of possible flow patterns will develop as the discharge waste stream mixes in the ambient water. These flow patterns will determine the configuration, size, and intensity of the mixing process, and any impact of the discharge on the water body surface, bottom, shoreline, or other areas.

All aqueous discharges located within the United States are subject to Federal and/or state regulation. A key aspect of these regulations is the concept of mixing zones. The mixing zone is a legally defined spatial quantity that allows for the initial mixing of the discharge. Legal criteria specify the mixing zone shape and effluent concentrations that must be maintained outside and at the edge of the mixing zone. The mixing zone is an allocated impact zone where more stringent ambient water quality standards may be exceeded locally. Current mixing zone regulations are a descendant of Federal water quality legislation commencing in 1948.

More recent regulations on discharges of aqueous toxic substances define additional subregions within the usual

mixing zone. The intent of these regulations is to require rapid mixing of toxic releases to limit exposure of toxic materials to aqueous flora and fauna.

The mixing behavior of the discharge is dependent on the depth of the ambient water body, the momentum and buoyancy of the discharge, the spatial orientation of the discharge, and the effects of many other factors. Detailed engineering analysis is necessary to provide estimates of discharge dilution within the mixing zone.

This work describes the development and implementation of an engineering tool -- in the form of a micro-computer based expert system -- for the analysis of submerged single port discharges into water bodies with variable and complex ambient conditions. The purpose of the expert system is to provide reliable and accurate predictions of the mixing characteristics of such discharges within the framework of the applicable legal requirements.

1.2 Overview of U.S. Water Quality Policy

Prior to 1948, states, local, and regional agencies were primarily responsible for controlling water pollution. After the realization in the mid-1800s of the role of contaminated water in the transmission of disease, state boards of health were formed to administer water pollution control programs. Most early pollution control programs focused on water-borne infectious diseases like typhoid and cholera (Ortolano, 1984).

Table 1.1 outlines key federal water pollution control legislation since 1948. The 1948 Water Pollution Control Act was designed to provide technical services to the states to strengthen their water pollution control programs. The 1948 Act focused on the primacy of the state role in water quality management.

The Federal Water Pollution Control Act (FWPCA) of 1956 expanded the federal role in controlling water pollution. The Act provided a program of subsidies for municipal treatment plant construction, strengthened powers of enforcement against polluters, increased funding for state water pollution control efforts, and provided new support for research and teaching. Each of these programs was included in the many amendments to the Act in the 1960s and 1970s.

The Water Quality Act of 1965 set new requirements for states to establish ambient water quality standards and increased the level of federal funding. Water quality

Table 1.1 Key Federal Water Pollution Control Laws
Source: Ortolano, 1984

Year	Title	Selected New Elements of Federal Strategy ^a
1948	Water Pollution Control Act	Funds for state water pollution control agencies Technical Assistance to states Limited provisions for legal action against polluters
1956	Federal Water Pollution Control Act (FWPCA)	Funds for water pollution research and training Construction grants to municipalities Three stage enforcement process
1965	Water Quality Act	States set water quality standards States prepare implementation plans
1972	FWPCA Amendments	Zero discharge of pollutants as a goal BPT and BAT effluent limitations NPDES permits Enforcement based on permit violations
1977	Clean Water Act	BAT requirements for toxic substances BCT requirements for conventional pollutants
1981	Municipal Waste Treatment Construction Grants Amendments	Reduced federal share in construction grants program

^aThe table entries include only significant new changes established by the law.

standards were designed to protect designated water uses within a stretch of river. The Act required that state agencies set water quality criteria to meet these standards. Criteria established the suitability of water for different activities. If the uses of water within a stretch of river and the criteria designed to protect those uses were known, ambient water quality standards could be set.

1.2.1 The Federal Water Pollution Control Act of 1972

Prior to the 1972 Federal Water Pollution Control Act (FWPCA) only the states had power to develop ambient water quality standards applicable to interstate or navigable waters. Water quality standards depended upon intended use, whether agricultural, industrial, or recreational.

Enforcement of water quality standards was only possible if water quality fell below standards. This hampered enforcement efforts because proof of causation was difficult in waters receiving wastes from various polluters. A state could lower its water quality standards to attract industry away from states that had more stringent water quality standards.

Congress decided to take rigorous action in 1972 with the FWPCA amendments. The Act established a uniform system of water quality standards, permits, and enforcement. The "goals" of the legislation were to produce fishable, swimmable water by 1983 and a total elimination of water pollution by 1985 (Findley and Farber, 1983).

Major changes in the FWPCA of 1972 included i) national water quality goals, ii) technology-based effluent limitations, iii) a national discharge permit system, and iv) a provision for federal court action against sources in violation of permit conditions (Ortolano, 1984).

Congressional intent in passing the FWPCA was to rule out arguments of assimilative capacity of receiving waters. Congress wanted uniformity of standards and enforcement. Ambient water quality standards were intended to be "more stringent" than effluent standards. The aim of the 1972 amendments was to restore and maintain "the chemical, physical, and biological integrity of the nation's waters" (Weyerhaeuser Co. v. Costle 590 F.2d 1001).

The 1972 amendments gave broad powers to the federal Environmental Protection Agency (USEPA) administrator to define pollutants and to determine and promulgate effluent limitations. Effluent limitations were set according to industry through the National Pollution Discharge Elimination System (NPDES) permit system. These discharge

limits were set independent of the particular context in which the pollution discharge occurs. Dischargers in violation of NPDES pollution limits were subject to enforcement action.

The Act contained ambient water quality standards that supplemented federal discharge standards for point sources. Point sources were defined as "any discernable, confined, and discrete conveyance from which pollutants are, or may be discharged."

The 1972 FWPCA required that industry dischargers meet "best practicable control technology currently available" (BPT) standards by 1977 and "best available technology economically achievable" (BAT) standards by 1983.

The Act required public sources of pollution to use secondary treatment by 1977 and use "best practicable waste treatment over life of the works" by 1983.

Specific sections of the Act include:

Section 301 of the Act set standards for point sources that were not publicly owned treatment works (POTW). It requires dischargers to reduce emissions using "best practicable control technology currently available" (BPT) by 1977 and "best available technology economically achievable" (BAT) by 1983.

Section 302 of the Act set ambient water quality standards. Ambient water quality standards were to comply with state or federal law, whichever was more stringent to achieve ambient water quality goals.

Section 306 of the Act pertains to new sources. This section required such facilities to meet standards equivalent to 1983 BAT standards.

Section 307 covers toxic water pollutants. It requires that standards be developed for toxic water pollutants based on public health and welfare and not technical feasibility.

Section 402 of the Act empowers the federal government to create a National Pollution Discharge Elimination System (NPDES). This pollution permit system empowers the USEPA to set national effluent standards and grants states, with USEPA approval, the responsibility of administering the program. NPDES applies to any discharge to receiving waters. NPDES permits had to incorporate applicable limitations under sections 301, 302, 306, and 307 of the Act, including enforcement to meet 1977 and 1983 deadlines.

Section 505 provides the right of citizen suits to enforce provisions of the Act. States have the primary responsibility to enforce the provisions of the Act, but the Federal government has the right to step in and enforce any provision of the Act.

1.2.2 The Clean Water Act of 1977

In 1977 the FWPCA Act was amended by Congress. These amendments are known as the Clean Water Act (CWA). The five general categories of pollutants covered in the Act are; i) conventional, ii) nonconventional, iii) toxics, iv) heat, and v) dredge and fill spoil. The Act distinguishes between new and existing sources for setting effluent standards. Table 1.2 lists examples of the first three pollutant categories.

Pollutants designated as "conventional" would be "as defined by the administrator in compliance with the Act as amended, generally those pollutants that are naturally occurring, biodegradable, oxygen demanding materials and solids. In addition, compounds which are not toxic and which are similar in characteristic to naturally occurring, biodegradable substances are to be designated as conventional pollutants for the purposes of the provision" (Congressional Research Service, 1977). Pollutants designated as "nonconventional" would be "those which are not toxic or conventional" (Congressional Research Service, 1977). Table 1.3 illustrates the kinds of effluent standards set by USEPA under the 1977 amendments.

A new class of effluent standards called "best conventional pollution control technology" (BCT) were created for conventional pollutants. Cost consideration could be taken into account by USEPA in determining BCT effluent regulations for conventional pollutants, but not for nonconventional pollutants or toxics.

Congress modified BAT standards in the Clean Water Act of 1977. This action was in response to criticism that the original BAT effluent limitations required too high a percentage removal of pollutants and the cost of reduction in these residuals would be much greater than the benefits. BAT standards apply to unconventional and toxic pollutants. A variance provision for BAT standards for nonconventional pollutants is contained in section 301(g) of the Act. It allows the USEPA along with state approval to modify effluent standards for nonconventional pollutants if this did not interfere with water quality standards or public health.

Table 1.2 Examples of Conventional, Nonconventional, and Toxic Pollutants

Source: Technical Guidance Manual For The Regulations Promulgated Pursuant to Section 301(g) of the CWA 1977, USEPA, 1984.

Conventional	Nonconventional	Toxic
biochemical oxygen demand (BOD)	chemical oxygen demand (COD)	chloroform
pH	fluoride	lead
total suspended solids (TSS)	aluminum	fluorene
fecal coliform bacteria	sulfide	nickel
oil and grease	ammonia	selenium
		benzidine

Table 1.3 Examples of Technology-Based Effluent
Limitations Under The Clean Water Act of 1977

Source: Ortolano, 1984.

Publicly Owned Treatment Works:

Requirements for 85% BOD removal, with possible case-by-case variances that allow lower removal percentages for marine discharges.

Industrial Discharges (bases for effluent limitations):

Toxic pollutants - BAT

Conventional pollutants - BCT; in determining required control technology, USEPA is directed to consider "the reasonableness of the relationship between the costs of attaining a reduction in effluent and the effluent reduction benefits derived."

Nonconventional pollutants - BAT, but with possible case-by-case variances that allow for lower degrees of treatment.

percentage removal of pollutants and the cost of reduction in these residuals would be much greater than the benefits. BAT standards apply to unconventional and toxic pollutants. A variance provision for BAT standards for nonconventional pollutants is contained in section 301(g) of the Act. It allows the USEPA along with state approval to modify effluent standards for nonconventional pollutants if this did not interfere with water quality standards or public health.

All river segments within states are classified as water quality limited or effluent limited under section 303(e) of the Act. Effluent limited segments are defined as those stream reaches for which ambient water quality standards can be met in 1977 by application of best practicable control technology currently available (BPT) to industry and secondary treatment to publicly owned treatment works (POTW). When ambient water quality standards cannot be met by BPT for industry and secondary treatment for POTW, these reaches are classified as water quality limited.

1.3 The Concept of Mixing Zones

1.3.1 Mixing Zones: Development and Regulations

The mixing zone is defined as an "allocated impact zone" where numeric water quality criteria can be exceeded as long as acutely toxic conditions are prevented. A mixing zone can be thought of as a limited area or volume where the initial dilution of a discharge occurs (Water Quality Standards Handbook, 1984). Water quality criteria apply at the boundary of the mixing zone, not within the mixing zone itself. USEPA and its predecessor agencies have published numerous documents giving guidance for determining mixing zones such as the National Academy of Science Water Quality Criteria 1968 (Green Book), USEPA publications Quality Criteria for Water 1976 (Red Book), and Guidelines for State and Area Wide Water Quality Management Program. Guidance published by USEPA in Water Quality Standards Handbook (1984) supersedes these sources.

In setting requirements for mixing zones, USEPA (1984) requires that "the area or volume of an individual zone or group of zones be limited to an area or volume as small as practicable that will not interfere with the designated uses or with the established community of aquatic life in the segment for which the uses are designated," and the shape be "a simple configuration that is easy to locate in the body of water and avoids impingement on biologically important areas," and "shore hugging plumes should be avoided."

Within the mixing zone USEPA requires "any mixing zone should be free of point or nonpoint source related:

- (a) Material in concentrations that will cause acute toxicity to aquatic life;
- (b) Materials in concentrations that settle to form objectionable deposits;
- (c) Floating debris, oil scum and other matter in concentrations that form nuisances;
- (d) Substances in concentrations that produce objectionable color, odor, taste or turbidity; and
- (e) Substances in concentrations which produce undesirable aquatic life or result in a dominance of nuisance species." (USEPA, Water Quality Standards Handbook, 1984).

The proposed rules for mixing zones recognize that the state has the discretion to adopt or not to adopt a mixing zone and to specify its dimensions. USEPA allows the use of a mixing zone in permit applications except where one is prohibited in state regulations. State standards require that water quality criteria be met at the edge of the regulatory mixing zone i) to provide a continuous zone of free passage that meets water quality criteria for free-swimming and drifting organisms and ii) to prevent impairment of critical resource areas (USEPA, Technical Support Document for Water Quality-based Toxics Control, 1985). A review of individual state mixing zone policies shows that 48 out of 50 states make use of a mixing zone in some form (Table 1.4).

The mixing zone dimensions vary from state to state as shown in Table 1.4. The mixing zone can be defined as a downstream distance, cross-sectional area, or volume of water. Discharge concentrations of pollutants such as nitrogen, phosphorus, or toluene, are limited to certain numerical values at the edge of the mixing zone.

For discharges into streams, 17 of the 31 states that propose a mixing zone specify that the mixing zone shall not exceed 1/4 of the cross-sectional area and/or volume of the stream flow, and the remaining 3/4 of the stream shall be maintained as a zone of passage for swimming and drifting organisms.

The remaining states have varying requirements allowing dimensions of the mixing zone to be as low as 1/5 of the cross-sectional area (Ohio) to as much as 3/4 of the cross-sectional area (South Dakota). West Virginia is the only state that specifies a length dimension for mixing zones.

Table 1.4 State Legal Mixing Zones

Source: Draft Technical Guidance Manual for the Regulations Promulgated Pursuant To Section 301(g) (USEPA 1984)

State	Water Body	Dimensions
Alabama	0	0
Alaska	river, streams lakes	<= 1/3 CS <= 10% SA
Arizona	NR	NR
Arkansas	large streams	<=1/4 CS
California	0	0
Colorado	0	0
Connecticut	streams	<=1/4 CS
Delaware	streams lakes	<=1/3 CS <=10% SA
D.C.	estuary	<=10% SA
Georgia	0	0
Florida	streams, rivers lakes, estuaries	<=800 meters <=10% total length <=125,600 m**2 (600' radius) <=10% SA
Hawaii	0	0
Idaho	0	0
Illinois	all streams	<=600' radius <=1/4 CS
Indiana	streams	<=1/4 CS
Iowa	streams	<=1/4 CS
Kansas	streams	<=1/4 CS
Kentucky	streams	<=1/3 CS
Louisiana	streams	<=1/4 CS
Maine	streams	<=1/4 CS
Maryland	0	0
Massachusetts	0	0
Michigan	streams Lake Michigan	<=1/4 CS <=1000' radius
Minnesota	streams	<=1/4 CS
Mississippi	0	0
Missouri	streams	<= 1/4 CS
Montana	0	0
Nebraska	0	0
New Jersey	streams	< = 1 / 4 CS (thermal)
New Hampshire	streams	<=1/4 CS
New Mexico	streams	<=1/4 CS
New York	streams	<=1/2 CS (thermal)

Table 1.4 (Continued)

State	Water Body	Dimensions
Nevada	streams	$\leq 1/3$ CS
North Carolina	0	0
North Dakota	streams	$\leq 1/4$ CS
Ohio	receiving watercourse	$\leq 1/3$ CS
	mouth of receiving	$\leq 1/5$ CS
Oklahoma	streams	$\leq 1/4$ CS
Oregon	0	0
Pennsylvania	NR	NR
Rhode Island	streams	$\leq 1/4$ CS (thermal)
South Carolina	0	0
S. Dakota	streams	$\leq 3/4$ CS or 100 yds of stream's width
Tennessee	0	0
Texas	streams	$\leq 1/4$ CS
Utah	0	0
Vermont	streams	$\leq 1/4$ CS
Virginia	0	0
Washington	0	0
W. Virginia	warm water fish streams	$\leq 33\%$ CS, length $\leq 10 \times$ width
	cold water fish streams	$\leq 20\%$ CS, length $\leq 5 \times$ width
	lakes	$\leq 300'$ any direction
Wisconsin	streams	$\leq 1/4$ CS
Wyoming	0	0
Guam	0	0
Puerto Rico	streams	$\leq 1/4$ CS IMZ $\leq 400'$ FMZ $\leq 4000'$
Virgin Islands	streams	$\leq 1/4$ CS

Where:

CS = cross-sectional area
NR = no reference
IMZ = initial mixing zone

SA = surface area
0 = not listed
FMZ = Final mixing zone

The length of the mixing zone must be less than 10 times the average width of the stream or less than 5 times the average width of the stream for warm water and cold water streams, respectively.

In states that specify a mixing zone for lakes, dimensions for the mixing zone vary from 10% of the surface area of the lake to 300 to 1000 foot radial limits around the discharge point.

Pennsylvania and Arizona are the two states that do not make reference to a mixing zone. Therefore the USEPA does not recognize any mixing zone for these states and water quality criteria must be met at the point of discharge unless the applicant and the state develop a mixing zone on a case by case basis.

Usually, the size of the mixing zone is determined on a case-by-case basis taking into account the critical resource areas that need to be protected. Mixing zones should be used and evaluated in cases where mixing is not complete within a short distance of the outfall.

1.3.2 Special Mixing Zone Requirements for Toxic Substances

For toxic discharges, USEPA recommends careful evaluation of mixing to prevent zones of chronic toxicity that extend for excessive distances because of poor mixing. USEPA maintains two water quality criteria for the allowable magnitude of toxic substances: a criterion maximum concentration (CMC) to protect against acute or lethal effects; and a criterion continuous concentration (CCC) to protect against chronic effects (USEPA, 1985).

The less restrictive criterion, the CCC, must be met at the edge of the same regulatory mixing zone specified for conventional and nonconventional discharges.

To prevent lethal concentrations of toxics in the regulatory mixing zone, the restrictive CMC criterion must be met within a short distance from the outfall or in the pipe itself. If dilution of the toxic discharge in the ambient environment is allowed, this requirement, which will be defined here as a toxic dilution zone (TDZ), is more restrictive than the legal mixing zone for conventional and nonconventional pollutants. The technical support document specifies a minimum exit velocity of 3 meters per second (10 feet per second), in order to provide sufficiently rapid mixing that will minimize organism exposure time to toxic material. In addition, the outfall design also must meet three geometric restrictions for a TDZ (USEPA, Technical

Support Document for Water Quality-based Toxics Control, 1985):

-The CMC must be met within 10% of the distance from the edge of the outfall structure to the edge of the regulatory mixing zone in any spatial direction.

-The CMC must be met within a distance of 50 times the discharge length scale in any spatial direction. The discharge length scale is defined as the square-root of the cross-sectional area of any discharge outlet. This restriction will ensure a dilution factor of at least 10 within this distance under all possible circumstances, including situations of severe bottom interaction and surface interaction.

-The CMC must be met within a distance of 5 times the local water depth in any horizontal direction. The local water depth is defined as the natural water depth (existing prior to the installation of the discharge outlet) prevailing under mixing zone design conditions (e.g. low flow for rivers). This restriction will prevent locating the discharge in very shallow environments or very close to shore, which would result in significant surface and bottom concentrations.

1.4 Regulatory Assessment of Discharges and the Permitting Process

1.4.1 The NPDES Permit System

Any pollutant discharge into a navigable watercourse must have a National Pollution Discharge Elimination System (NPDES) permit. The permit is designed to insure that the discharge meets all applicable standards. The permit is granted either by USEPA, or, if the state has a USEPA approved program, by the state. The applicant must supply the reviewing agency with all data needed to grant the permit. Data required in the application include:

- Name and exact location of facility
- Nature of business engaged at the facility, including what is or what will be manufactured
- The manufacturing process and maximum production levels
- Schematic of water flow through the facility
- Exact location, flow rates, flow frequencies, and chemical composition of each facility discharge

- The waste-water treatment currently or to be employed for each waste stream
- Pollutant test data

1.4.2 Need for Regulatory Assessment Tools

Implementation of the mixing zone policy requires that both applicants and regulators determine the initial dilution of the discharge and the characteristics of the mixing zone. If the discharge is toxic, the CMC value must be determined for the discharge and special requirements for a TDZ must be met within the mixing zone. Given the large number of possible ambient environments, discharge configurations, and mixing zone definitions, the analyst needs considerable training and experience to conduct accurate and reliable effluent mixing analysis.

Dilution of the effluent in the receiving water is caused by different mechanisms along its path. In the "near-field" of the source, dilution is caused mainly by jet induced entrainment. Further away, in the so-called "far-field" the jet velocity decreases and ambient diffusion becomes the primary mechanism of effluent dilution.

The most direct way of determining pollutant concentration downstream is by physical measurement. Non-polluting tracers also can be injected to give indications of effluent dilution. Such field studies require considerable time and effort, and field personnel need specialized training to perform studies reliably. Field studies, in many cases, are impractical and expensive. For example, if in situ observations are used they must represent conditions that are present during critical dilutions, not merely a typical dilution (USEPA, Draft 301(g) 1984). Field studies for analyses of dilution for toxic discharges are patently unacceptable, so simulation must be used to determine dilutions.

Because of the complexity of the physical mixing process, permit writers are increasingly relying on mathematical models to analyze the transport and transformation of pollutants (Tait, 1984). The difficulty with many present models is that they tend to become specialized and give accurate results only for a particular type of outfall. The user must be careful to use a model that was intended to make predictions under the conditions with which he is concerned (USEPA Draft 301 (g) 1984).

USEPA has developed a number of models to predict the initial dilution of discharges. A few these are known as

PLUME, OUTPLM, UDKHDEN, MERGE, and LINE (Muellenhoff et al. 1985). Applicants are not required to use these models in the analysis, but must be able to prove that the methodology chosen gives reasonable estimates of initial dilution.

1.4.3 Motivation for Expert Systems Approach

In determining the characteristics of the mixing zone, the analyst, either the NPDES applicant or regulatory authority, may choose from a wide variety of predictive models. The models range in complexity from simple analytical formulae to highly intricate numerical solutions to differential equations. Although the USEPA has prepared assessment manuals and actually endorsed certain models in specific situations, the average user has little reliable guidance on which model is appropriate for a particular situation, or which is actually best (Muellenhoff, et al., 1985). Examples of "model abuse" are ubiquitous. Often unnecessarily complicated models are employed, creating a needless burden for both regulators and dischargers.

Even when a particular model is appropriate for a given discharge, the model may not give reliable results over a wide range of conditions. Model developers often fail to explicitly specify limits of applicability, or model users may simply overlook important restrictions to model applicability. An example of a frequent error in the application of the USEPA plume models is the violation of the assumption of the infinite receiving environment (Muellenhoff, et al., 1985). In reality, the plume may attach to the bottom or may become vertically fully mixed, possibilities that may occur due to changes in the ambient environment such as low flow conditions. Consequently, analysts have submitted model "predictions" in which the plume diameter exceeds actual water depth!

Once the correct choice of model is assured, the analyst often faces the considerable task of assembling the required design data base. This can be a frustrating and cumbersome task for the unexperienced analyst who has little guidance on what design base to choose, where to obtain data, which data are crucial to the analysis, and which data may simply be estimated. Because of these difficulties, a large investment in time is required for the analyst to become fully familiar and proficient with the use of at least one model, or more likely, a group of models. The analyst in reality must become highly skilled or an "expert" in the use and interpretation of a number of simulation models. Such expertise in model use requires expensive training and is rare. This is the primary reason for the development of expert system tools to assist the analyst.

In essence, expert systems mimic the way an expert or highly experienced person would solve a problem. An expert system is a structured computer program that uses knowledge and inference procedures obtained from experts for solving a particular type or class of problem called a "domain". This knowledge is encoded into a "knowledge base" that enables inexperienced personnel to solve complex problems by using the same basic reasoning process that an expert would apply. The knowledge base includes a set of "objective" or widely accepted facts about a general problem area. This includes the set of parameters or data an expert would seek in order to characterize a specific problem. The inference procedures are "subjective" rules of judgement that the expert might use when analyzing the problem. The inference procedures provide the rules for selecting an appropriate solution to the problem from the knowledge base. The inference procedures allow the expert system user to search rapidly and systematically through the knowledge base to obtain a solution to the given problem. This element uses structured search techniques based upon mathematical logic.

The development of an expert system for mixing zone analysis promises significant advantages compared with existing conventional simulation techniques for water pollution control and management:

- it assures the proper choice of model for a given physical situation.
- it assures that the chosen model is applied methodically without skipping essential elements.
- it guides the acquisition or estimation of data for proper model prediction.
- it allows a flexible application of design strategies for a given point source, screening of alternatives, and if necessary, switching to different predictive models thus avoiding rigid adherence to a single model.
- it flags borderline cases for which no predictive model exists suggesting either avoidance of such designs or caution by assigning a degree of uncertainty.
- it allows a continuous update of the knowledge base as improved predictive models, experimental data, and field experience with particular designs become available.
- it provides a documented analysis listing the knowledge and decision logic that have lead to the

problem solution. Thus, unlike conventional programs or computer algorithms an expert system is not a "black box."

- it provides a common framework whereby both regulators (federal or state), applicants, and the scientific community can arrive at a consensus on the state-of-the-art hydrodynamic mixing and pollution control.
- it gives pollutant concentration at the specified regulatory mixing zones.
- finally, and perhaps most importantly, it provides a teaching environment whereby the initially inexperienced analyst through repeated interactive use gains physical insight and understanding about initial mixing processes.

1.5 CORMIX1: An Expert System for Mixing Zone Analysis of Submerged Single Port Aquatic Discharges

1.5.1 Scope and Objective

The Cornell Mixing Zone Expert System (CORMIX) is a series of software subsystems for the analysis, prediction and design of aqueous conventional or toxic pollutant discharges into watercourses, with emphasis placed on the geometry and dilution characteristics of the initial mixing zone. Subsystem CORMIX1, described in this work, deals with submerged single port discharges with arbitrary discharge buoyancy (positive, negative, or neutral) into arbitrary water bodies (shallow or deep, stagnant or flowing, uniform or stratified) as may be representative for rivers, lakes, reservoirs, estuaries, or coastal waters. CORMIX1 assumes steady state flow conditions, both for the discharge and the ambient environment. Another subsystem, CORMIX2, addresses submerged multiport diffuser discharges (Akar and Jirka, 1989). CORMIX3, the third possible development, would be for the analysis of surface discharges.

The objective of the expert system is to provide the analyst with accurate and reliable predictions of discharge mixing processes. The expert system should be easy to use, and should allow for preliminary mixing zone analysis of a typical design in perhaps 20 minutes if all necessary input data is available. Emphasis is placed on the geometry and initial mixing of the discharge, along with prediction of concentration (or dilution) values and the shape of the regulatory mixing zones. The expert system should provide the analyst with detailed hydrodynamic information and recommendations for discharge design, including sensitivity studies.

Since its emphasis is on initial mixing mechanisms with their short time scales, CORMIX1 assumes a conservative pollutant or tracer in the effluent. Thus any physical, chemical, or biological reaction or decay processes are neglected. However, if first-order processes are assumed the predictive results can be readily adjusted to include such processes (see Section 7.4).

It seems impossible, and probably unnecessary, to develop a system that works reliably for every conceivable mixing zone and discharge configuration. The present philosophy, however, was to develop an expert system that works for the large majority (better than 95%) of typical discharges, ranging from simple to fairly complex cases. The remaining cases may require separate analyses, perhaps using sophisticated numerical modeling or a detailed hydraulic model study.

1.5.2 Results of an Earlier Feasibility Study

A feasibility study (Doneker and Jirka, 1988) was conducted to test expert system methodology for the analysis and design of submerged single-port continuous buoyant discharges into a non-stratified flowing aqueous environment. The objective was to test a prototype of the hydrodynamic knowledge base and simulation model. This simplified expert system did not include stratified environments, negatively buoyant discharges, and bottom attachments. The system was written in the expert system shell M.1 (Tecknowledge, Inc.) and in Fortran.

The results of the hydrodynamic simulation were found to be in good to excellent agreement with available field and laboratory data. In particular, the system proved flexible and reliable in distinguishing among complex discharge situations involving boundary interactions and buoyant intrusion phenomena. Many of the common pitfalls to model use -- incomplete or contradictory data, choice of appropriate simulation model, and faulty interpretation of results -- appear to have been mitigated within the context of an expert system methodology. Because of the encouraging results of the preliminary system, the more general hydrodynamic problems of negative buoyancy, stratified environments, and boundary attachments, along with more sophisticated user elements, have been included in the expert system described herein.

1.5.3 Summary of Present Study

CORMIX1 uses the expert systems shell VP-Expert (Paperback Software, Inc.) and Fortran. The following chapters provide a detailed description of the expert system CORMIX1. Chapter II provides a detailed review of basic hydrodynamic processes of mixing in buoyant jets, buoyant spreading, passive ambient diffusion, and boundary interaction phenomena.

A hydrodynamic flow classification system is developed in Chapter III. The classification system describes the physical discharge/environment interaction processes controlling near-field mixing for a discharge, and forms the basis for the construction of the proper hydrodynamic simulation model sequence.

Chapter IV presents an outline of the computer programs in CORMIX1. This chapter describes the logic and Fortran program elements of CORMIX1, their respective strengths and weaknesses, and how they are applied to mixing zone analysis.

Chapter V discusses the hydrodynamic model protocols used to simulate a given discharge/environment condition. The details of each simulation program element are also presented.

Chapter VI is devoted to system evaluation and validation. This chapter compares CORMIX1 results with a wide range of laboratory and field data. Comparisons are given with jet integral models that are widely used but are limited to the initial subsurface buoyant jet processes.

Chapter VII presents design case studies to illustrate the flexibility and power of the system to evaluate a wide range of typical discharge/environment situations. Also suggestions on extending the applicability of the system to other possible discharge/environment conditions is given.

Chapter II

Hydrodynamic Elements of Mixing Processes

The hydrodynamics of an effluent continuously discharging into a receiving body of water can be conceptualized as a mixing process occurring in two separate regions. In the first region, the initial jet characteristics of momentum flux, buoyancy flux, and outfall geometry influence the jet trajectory and mixing. This region will be referred to as the "near-field", and encompasses the jet subsurface flow and any surface or bottom interaction, or in the case of a stratified ambient, terminal layer interaction. In this region, designers of the outfall can usually affect the initial mixing characteristics through appropriate manipulation of design variables.

As the turbulent plume travels further away from the source, the source characteristics become less important. Conditions existing in the ambient environment will control trajectory and dilution of the turbulent plume through buoyant spreading motions and passive diffusion due to ambient turbulence. This region will be referred to here as the "far-field".

The hydrodynamic analysis treats the near-field and far-field regions separately. An illustration of the near-field and the far-field of a simple positively buoyant subsurface plume rising to the surface and traveling downstream appears in Figure 2.1.

This chapter represents the basic hydrodynamic elements of the several stages within typical mixing processes that can occur in the water environment. In Section 2.1 the mechanics of buoyant jet mixing are presented, starting with the simple jet and plume. This analysis is extended to include the effects of crossflows, combined sources of momentum and buoyancy, and finally ambient density stratification. Section 2.2 deals with buoyant spreading processes in unstratified or stratified flowing ambients. Passive diffusion, due to ambient turbulent mixing, is summarized in Section 2.3. Finally various interaction processes that provide a transition between buoyant jet mixing and subsequent processes are presented in Section 2.4.

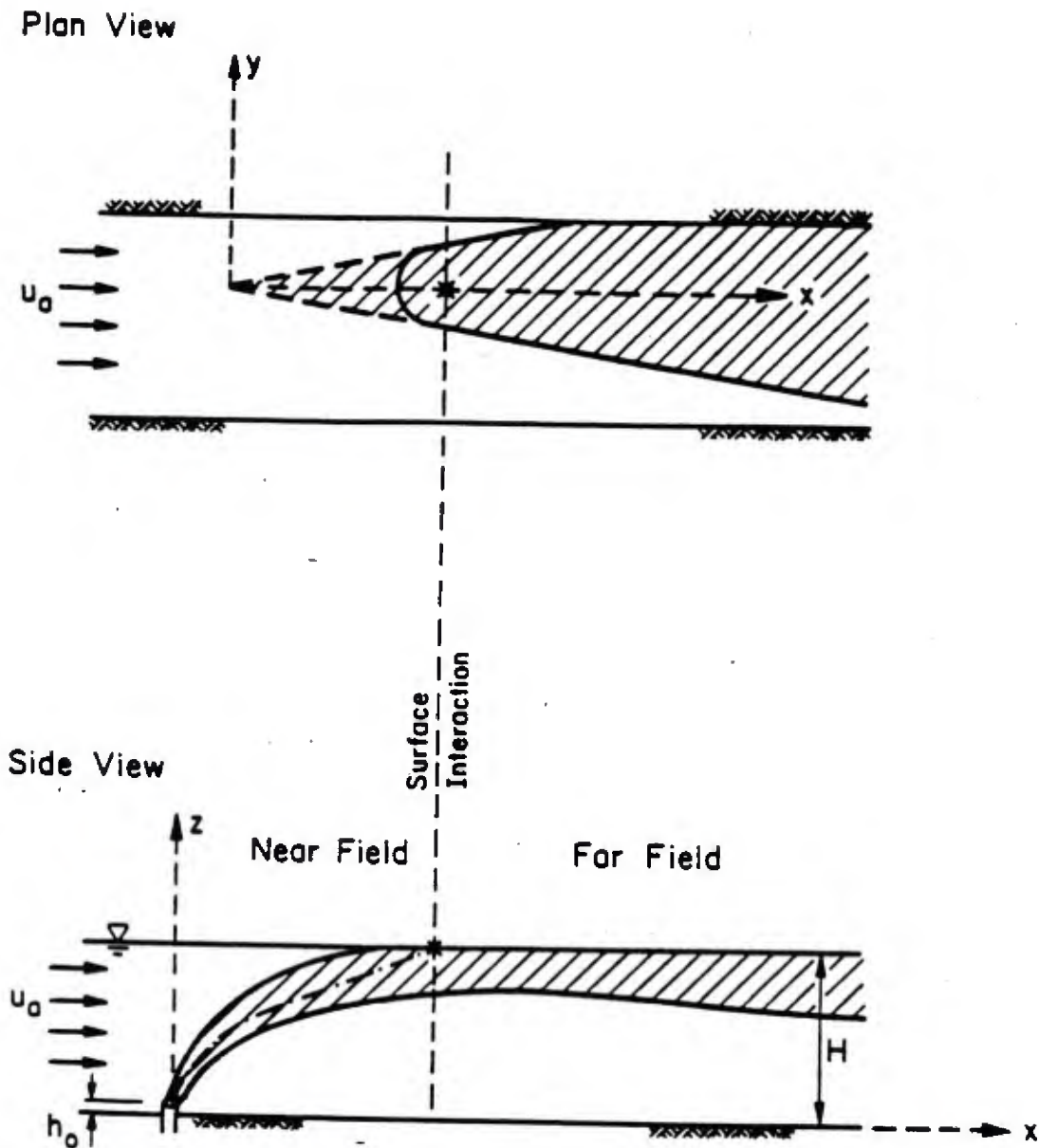

Figure 2.1 Illustrative Near-Field and Far-Field Regions of Submerged Positively Buoyant Discharge: An Example of Unstratified Ambient Water and Without Bottom Attachment

2.1. Buoyant Jet Mixing Processes

A discharge with no buoyancy is referred to as a "nonbuoyant jet" or "pure jet". A release of buoyancy only (no initial momentum) is called a "pure plume". A release containing both momentum and buoyancy is designated a "buoyant jet" or "forced plume". For simplicity, a region within the actual pure jet, pure plume, or buoyant jet will herein be referred to as a "flow". Positively buoyant flows are defined as flows where the buoyancy force acts vertically upwards against the gravity force; negative buoyancy is defined as acting downwards in the direction of the gravity force.

For a buoyant jet in a stagnant unstratified environment, List and Imberger (1973) propose three flow regions where buoyant jet behavior is determined by different effects. In the first region, near the issuing source, the geometry of the discharge is important. In the second region, initial kinematic momentum flux of the discharge predominates. In the third and ultimate region, yet further away from the source, buoyancy flux of the initial discharge becomes important. Characterizing the flow by the predominant mechanism controlling the flow within a region is the essence of "asymptotic analysis" which will be pursued herein.

The effects of momentum and buoyancy thus can be considered separately to reduce the number of independent variables under consideration. For example, the solution for a pure jet can be applied as an approximate solution to that portion of buoyant jet in a crossflow where jet momentum dominates the flow. Likewise the results for a pure plume can be applied to the buoyancy-dominated regions for the buoyant jet.

Additional factors, such as ambient crossflow and density stratification, can also be treated within the framework of asymptotic analysis as shown by Wright (1977), and others.

2.1.1 Description of Turbulent Jets and Plumes

Most people are familiar with the sight of smoke rising from a smokestack into the atmosphere. The smoke plume first rises vertically and spreads narrowly, and eventually bends over as it is carried away by the ambient wind. The smoke plume is an example of a turbulent buoyant jet, the discharge contains both momentum and buoyancy, and is affected, at least in the final stages by the crossflow.

The buoyancy is produced by the lower density of the heated air with respect to the cooler ambient air.

The discharge of a liquid such as sewage into the ocean behaves in a similar fashion. The sewage flow has momentum from being injected through the discharge orifice. The sewage may have the density of freshwater and thus is buoyant with respect to the greater density of the ambient saltwater.

2.1.2 Dimensional Analysis of Buoyant Jets

Turbulent jets are characterized by a long narrow turbulent zone. Following release from a nozzle, the jet flow becomes unstable at its boundary and breaks down into the turbulent motion. Typically, the size of the turbulent eddies increases with increasing distance along the trajectory (Holley and Jirka, 1986).

Several assumptions are made in order to reduce the independent variables under consideration. Only fully turbulent jets are considered so the effects of viscosity can be neglected. The Boussinesq approximation is assumed: density differences between the jet and the ambient environment are small and are important only in terms of the buoyancy force.

The three variables used to describe buoyant jet characteristics are the kinematic fluxes of mass, $Q_0 = (\pi/4)D^2u_0$ [L^3T^{-1}], momentum $M_p = u_0Q_0$ [L^4T^{-2}], and buoyancy $J_0 = g_0Q_0$ [L^4T^{-3}], where D [L] is the diameter of the orifice, u_0 [LT^{-1}] is the exit velocity, and g_0 [LT^{-2}] is the reduced gravitational buoyant acceleration caused by the density difference between the jet and ambient environment. This term is defined as $g_0 = g(\rho_s - \rho_0)/\rho_s$ where g is gravitational acceleration and ρ_s and ρ_0 are the ambient and jet discharge densities [ML^{-3}], respectively.

If the ambient water is flowing its velocity, u_s [LT^{-1}], becomes an additional variable. Furthermore, when the ambient density is not uniform, the density stratification may be written in terms of a buoyancy gradient defined as

$$\epsilon = -g/\rho_s(d\rho_s/dz) \quad [T^{-2}] \quad (2.1)$$

where z is the vertical coordinate direction. Note that the following assumptions are implicit in the above definitions: a uniform exit velocity u_0 , a constant ambient velocity (without shear) u_s , and a linear density gradient with, at least layer-wise, constant ϵ .

For the general case of a buoyant jet discharged into a flowing stratified environment, dimensional analysis proceeds as follows. Any dependent variable, ϕ , such as local centerline jet velocity, can be expressed as a function of the various independent variables:

$$\phi = f(Q_0, M_0, J_0, u_a, \epsilon, s) \quad (2.2)$$

where s [L] is the distance along the jet trajectory. The function on the right hand side of Eq. (2.2) has to be dimensionally consistent with the desired dependent variable.

The following paragraphs first present the details of dimensional analysis for the simple case of a pure jet and a pure plume in a stagnant environment. Then, the cases of jets and plumes in a crossflow are presented. Finally the effect of ambient density stratification on flow behavior is presented. In each case, the jet and ambient flow variables can be combined into various length scales that measure the relative forces affecting a flow within a particular trajectory distance.

The asymptotic approach will provide solutions that are valid only within certain specified regions and require experimentally determined coefficients. However, the individual solutions can be linked by appropriate transition conditions to provide an overall prediction for the complete problem.

2.1.2.1 Simple Jet in Stagnant Uniform Environment

Consider a pure jet in a stagnant ambient fluid (Figure 2.2). Initially as the flow exits the orifice the velocity profile is near uniform. After a short distance s along the jet trajectory, the velocity distribution is observed to be bell-shaped (Gaussian). The region where this velocity distribution transformation occurs is called the zone of flow establishment (zofe). The details of the zofe will not be considered in any of the following analysis; i.e. the jet is assumed to come from a point source.

The maximum velocity u_c occurs along the trajectory centerline and a similarity profile (Gaussian distribution) may be assumed for the velocity distribution. Similar conditions pertain to the centerline concentration c_c of pollutant (or tracer) mass. The jet centerline velocity u_c decreases with distance s from the orifice as the jet entrains the stagnant ambient fluid. However, the momentum flux M at any section along the trajectory is conserved and is equal to the initial momentum flux M_0 .



a. Instantaneous appearance

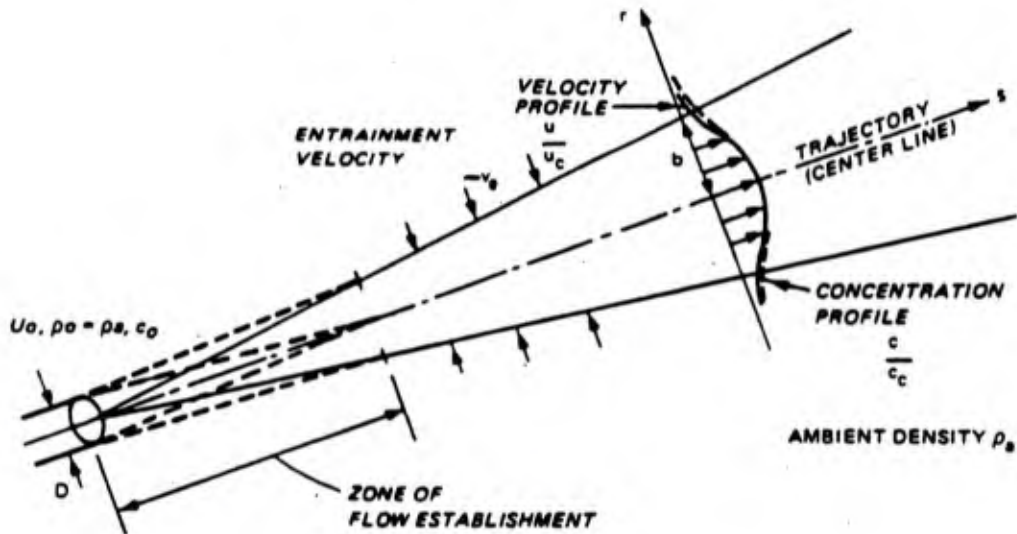

b. Time-averaged conditions

Figure 2.2 Pure Jet in Stagnant Environment (Ref. Holley and Jirka, 1986)

The magnitude and variation of the jet centerline velocity depends primarily upon the initial kinematic momentum flux and the distance along the trajectory, $u_c = f(M_0, s)$. Therefore, one can deduce on dimensional grounds

$$u_c = cM_0^{1/2}s^{-1}$$

(2.3) where c is a constant.

The width b of the jet at trajectory distance s can also be expressed as $b = f(M_0, s)$. The only possible dimensionally consistent equation is

$$b = cs \tag{2.4}$$

where c is another constant.

The centerline dilution S at any cross-section along the jet is defined by $S = c_0/c_c$, where c_0 is the concentration at the nozzle exit. A mass conservation equation implies $c_0Q_0 = c_c u_c b^2$, so that the dilution S as a function of s can be expressed as

$$S = cM_0^{1/2}s/Q_0 \tag{2.5}$$

where c is a constant.

The various jet flow constants c in the above three equations must be obtained from experimental data.

2.1.2.2 Simple Plume in Stagnant Uniform Environment

A pure positively buoyant plume rises vertically and experiences an increase in vertical momentum flux with distance z from the source (Figure 2.3). The buoyancy flux is constant for any cross-section of the plume as it rises. For the pure plume, the centerline velocity is a function of the buoyancy flux and distance, $u_c = f(J_0, z)$. The centerline velocity of the plume can be obtained from dimensional reasoning

$$u_c = c(J_0/z)^{1/3} \tag{2.6}$$

The width b of the plume at trajectory distance z is expressed as

$$b = cz \tag{2.7}$$

where c is a constant.

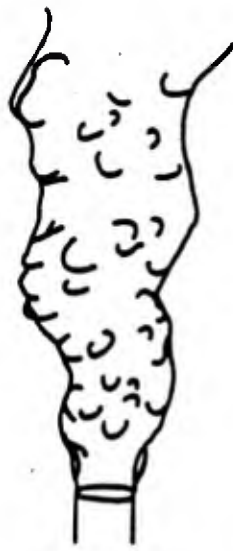

a. Instantaneous appearance

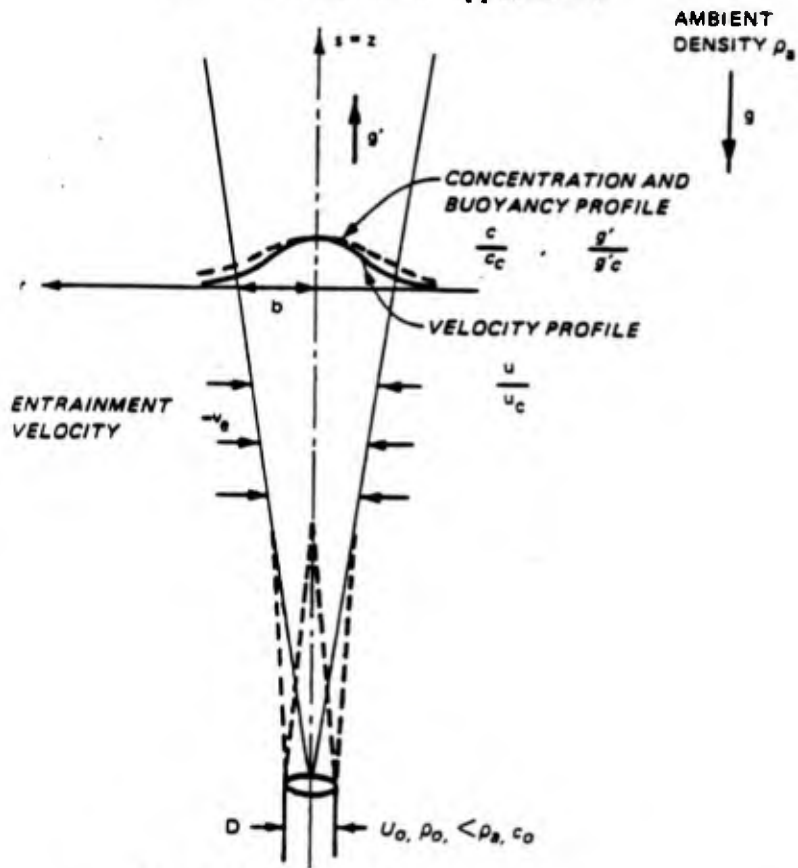

b. Time-averaged conditions

Figure 2.3 Simple Plume in Stagnant Environment (Ref. Holley and Jirka, 1986)

A mass conservation equation (similar to the approach leading to Eq. (2.5)) provides the plume dilution

$$S = cJ_0^{1/3}z^{5/3}/Q_0 \quad (2.8)$$

All plume flow constants c in the above equations are in general different from the jet flow constants and must be evaluated from experiments.

2.1.2.3 Generalizations: Jet/Plume Interactions, Crossflow Effects, and Stratification Effects

If several parameters influence the flow field, then a general asymptotic solution for the whole flow field cannot be found. However, there may be individual regions where specific asymptotic solutions of the type developed in the preceding sections still apply. This is illustrated in Figure 2.4.

A buoyant jet in unstratified stagnant ambient (Figure 2.4a) is initially jet-like and affected by the initial discharge orientation. After some distance the plume-like behavior predominates, leading finally to a vertical rise.

The role of an unstratified crossflow is to deflect the discharge flow downstream into the current direction. However, there is always a region close to the source where the flow is still jet-like (Figure 2.4b) or plume-like (Figure 2.4c). Beyond some distance the jet or plume becomes strongly deflected and is advected by the ambient flow.

The role of ambient stratification, given by a continuous linear distribution in the present case, is to trap the flow at a certain level (trapping level or terminal level). Prior to the trapping the flow may be either jet-like (Figure 2.4d) or plume-like (Figure 2.4e). After trapping the flow forms an internal density current with moderate additional mixing, as discussed in Section 2.2.

Of course, multiple effects of the types sketched in Figure 2.4 can all occur simultaneously in a given flow. In every case it is possible, however, to identify dominant flow zones and spatial regions. This identification is possible by means of appropriate length scales that are developed in the following sections. A rigorous flow classification scheme on the basis of such scales is described in Chapter 3.

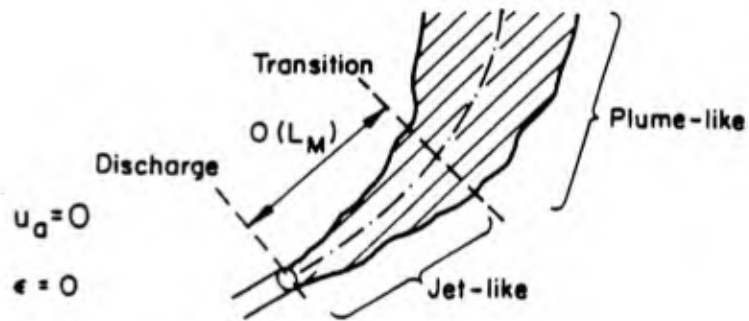

a) Buoyant Jet in Stagnant Uniform Environment

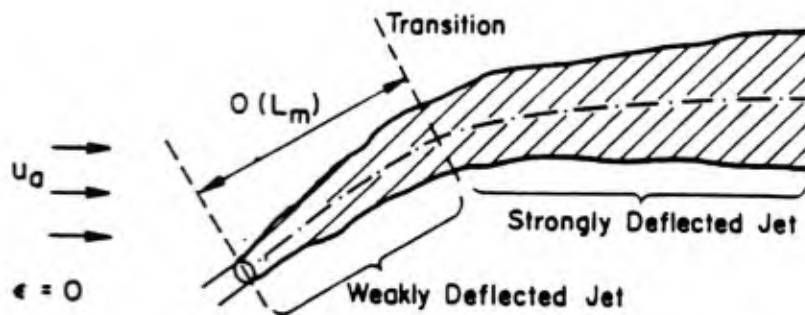

b) Pure Jet in Uniform Crossflow

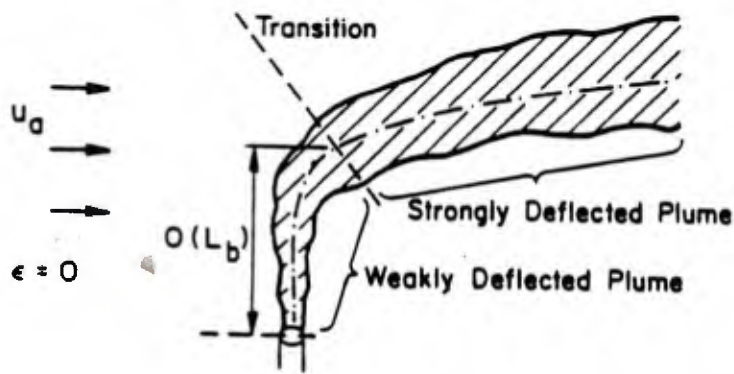

c) Pure Plume in Uniform Crossflow

Figure 2.4 Examples of Combined Effects of Momentum Flux, Buoyancy Flux, Crossflow, and Density Stratification on Flow Behavior

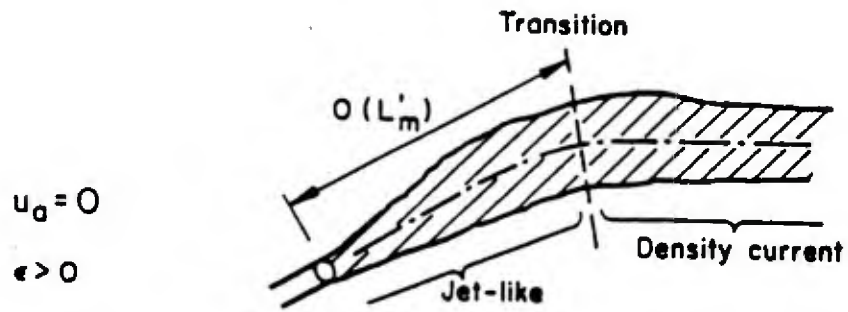

d) Pure Jet in Stagnant Stratified Ambient

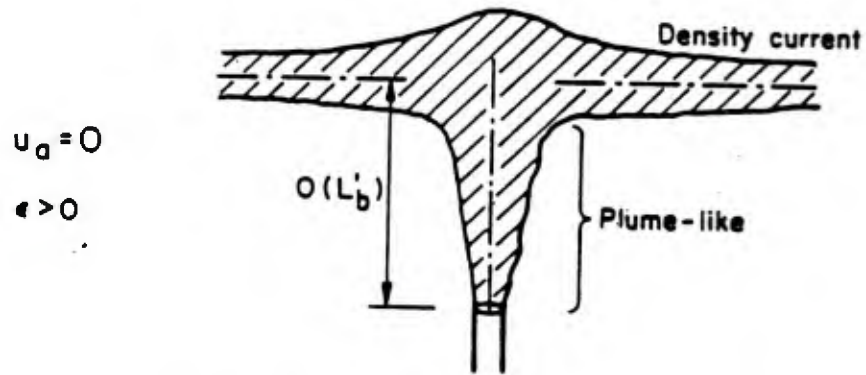

e) Pure Plume in Stagnant Stratified Ambient

Figure 2.4 (continued)

2.1.3 Length Scales

Length scales describe the relative importance of discharge volume flux, momentum flux, buoyancy flux, ambient crossflow, and density stratification in controlling flow behavior. The length scales will describe the distance over which these dynamic quantities control the flow.

2.1.3.1 Discharge Length Scale

Initially as the jet exits the port in the zone of flow establishment, port geometry controls the flow. The distance over which the port has effect on the flow can be characterized as a discharge length scale. The discharge length scale L_0 relates the volume flux to momentum flux, and from dimensional reasoning

$$L_0 = Q_0/M_0^{1/2} \quad (2.9)$$

which is proportional to the diameter D of the orifice for a round jet, $L_0 = (\pi/4)^{1/2}D$. For distances s from the source less than L_0 the flow will be in the zone of flow establishment. Thus if s/L_0 is less than the order of unity, or $s/L_0 \ll O(1)$, the source geometry will have a significant effect on the flow behavior, but for $s/L_0 \gg O(1)$ the effect of the initial geometry is lost to jet momentum or buoyancy which will control the flow behavior. Similar to the flow constants discussed in Section 2.1.2, the appropriate numerical value for the extent of this flow region must be obtained from experimental data; this holds for all the following "order of unity" statements.

2.1.3.2 Jet/Crossflow Length Scale

The presence of a crossflow u_c will deflect the jet as shown in Figure 2.4b. The behavior of the pure jet in crossflow depends on the relative magnitude of jet momentum to the crossflow. The distance to the position where the jet becomes strongly affected (i.e. deflected in the case of an oblique discharge) by the ambient crossflow is given by a jet/crossflow length scale L_m

$$L_m = M_0^{1/2}/u_c \quad (2.10)$$

Thus for $s/L_m \ll O(1)$ the initial jet momentum will dominate and crossflow is of secondary importance, and for $s/L_m \gg O(1)$ ambient velocity will have a strong influence on jet behavior.

2.1.3.3 Plume/Crossflow Length Scale

Arguments presented for the effect of crossflow on the pure plume flow are in analogy to those for a pure jet in crossflow. The plume/crossflow length scale L_b for the deflection of a vertically rising plume as shown in Figure 2.4c is given by

$$L_b = J_0 / u_c^3 \quad (2.11)$$

Thus for $z/L_b \ll O(1)$ the initial jet buoyancy will dominate and crossflow is of secondary importance, while for $z/L_b \gg O(1)$ ambient velocity will have a strong influence on plume behavior.

2.1.3.4 Jet/Plume Length Scale

The distance from momentum dominated to buoyancy dominated flow for a buoyant jet in a stagnant environment is characterized by a jet/plume length scale L_M (See Figure 2.4a). Dimensional analysis suggests the functional relationship

$$L_M = M_0^{3/4} / J_0^{1/2} \quad (2.12)$$

So for $z/L_M \ll O(1)$ flow behavior will be controlled by momentum and for $z/L_M \gg O(1)$ flow behavior will be controlled by buoyancy, i.e. approach that of a vertically rising plume.

In the rare case that $L_M \ll L_b$, there will be no momentum dominated flow and the flow will be entirely plume-like except for the region very near the issuing source.

The ratio of L_M/L_b is proportional to the usual discharge densimetric Froude number $F_0 = u_0 / (g_0' D)^{1/2}$ which relates the inertial forces to buoyancy forces within the plume, $L_M/L_b = (4/\pi)^{1/4} F_0$. The pure plume has a Froude number of $O(1)$ and the pure jet Froude number approaches infinity.

2.1.3.5 Jet/Stratification Length Scale

The effect of a linear ambient density stratification on a pure jet is to counteract the momentum flux of the flow as it travels away from the source. This is because the jet discharging with upward orientation entrains fluid of a greater density and carries it upwards where the ambient fluid is less dense. A reverse condition holds for a downward inclined jet. The jet/stratification length scale is given dimensionally by

$$L_m' = (M_0/\epsilon)^{1/4} \quad (2.13)$$

For a vertically discharging jet this length scale will be a measure of the distance to the terminal level of the jet flow. For a horizontally discharging jet L_m' will be a measure of the distance at which collapse of the jet flow will commence, with increasing lateral spreading and damped turbulent entrainment.

Thus for distance of $s/L_m' \ll 0(1)$ the effect of density stratification will be negligible on jet behavior. For distances of $s/L_m' \gg 0(1)$ the effect of stratification will be to terminate the jet motion and a density current will then form at the terminal level.

2.1.3.6 Plume/Stratification Length Scale

As for the pure jet in stratification, the effect of a linear ambient density stratification on a pure plume is to modify both buoyancy and momentum fluxes of the flow as it travels away from the source. The maximum height of rise of a simple plume in linear density stratification will be proportional to the plume/stratification length scale

$$L_b' = J_0^{1/4}/\epsilon^{3/8} \quad (2.14)$$

For a vertical distance of $z/L_b' \ll 0(1)$ the effect of density stratification on plume behavior will be negligible.

2.1.4 Typical Flow Regimes of Unconfined Buoyant Jets

This section presents a series of basic analytical results for jets or plumes in a variety of ambient situations. All of the results are perturbation solutions, in the sense that a simple analytical solution (e.g. the pure jet) is being perturbed by assuming a small effect of an additional variable (e.g. a weak crossflow).

For the following development the simplest possible assumptions are being made: a point source, either vertical or horizontal orientation, and only one perturbing variable. The results can be readily generalized to more complex conditions (e.g. arbitrary orientation or multiple influences). Indeed, such generalizations are implemented in the predictive elements presented in Chapter V.

2.1.4.1 Weakly Deflected Jet In Crossflow

For a relatively weak crossflow, the jet would behave the same as if it were in a stagnant environment, except that it is slightly advected by the ambient current (Figure 2.4b). This region is defined for $z/L_m \ll O(1)$, where z in this section signifies the coordinate pointing across the flow (e.g. vertically).

In first order, the vertical velocity for this jet flow would be similar to Eq. (2.3). In addition, a kinematic relationship applies for a jet element moving horizontally with the crossflow velocity in the direction x of the crossflow

$$dx/u_c = dz/u_c \quad (2.15)$$

Substitution for the vertical velocity given in Eq. (2.15) and integrating gives the trajectory relationship for the weakly deflected jet flow (Wright's (1977) "momentum-dominated near-field", or mdnf¹) expressed in terms of the jet/crossflow length scale

$$z/L_m = t_1(x/L_m)^{1/2} \quad (2.16)$$

where t_1 is a trajectory constant.

Eq. (2.16) is valid for small source dimensions, i.e. small values of L_0/L_m . In the special case that L_0/L_m is large, the effect of geometry is important and Eq. (2.16) no longer holds.

Jet width b is similar to the jet issuing in a stagnant environment given by Eq. (2.4) or

$$b = b_1 z \quad (2.17)$$

where b_1 is the spreading constant.

The dilution S is similar to Eq. (2.5), and is expressed in terms of L_0

¹In the following the abbreviated descriptions for crossflow influenced subsurface flows (mdnf, mdff, bdnf and bdnf) as suggested by Wright (1977) will be used for convenience since they are frequently used in the literature. Care must be exercised in their interpretation so as to avoid confusing them with the designation "near-field" and "far-field" as used in this study (see introductory comments at the beginning of this Chapter).

$$S = s_1(z/L_0) \quad (2.18)$$

where s_1 is the dilution constant for the mdnf flow.

2.1.4.2 Strongly Deflected Jet In Crossflow

For $z/L_m \gg 0(1)$ the ambient flow will dominate the flow pattern. For a strongly deflected jet the vertical velocity has decayed to less than the value for the ambient crossflow; thus the ambient crossflow will have significantly deflected the jet as shown in Figure 2.4b.

The behavior of the bent-over jet is assumed to be roughly equivalent to that of a cylindrical line impulse located at the same vertical rise. Scorer (1954) describes a line impulse as an instantaneous release of nonbuoyant fluid from a horizontal line source. The characteristic variables are the line impulse M' (defined as the kinematic momentum flux per unit length for an infinitesimal period of time), vertical rise z , and time after release t . Applying dimensional analysis

$$M't/z^3 = \text{constant} \quad (2.19)$$

To apply this analogy to the pure jet, M_0/u_a is substituted for M' and x/u_a replaces t in Eq. (2.19). The trajectory relation for the strongly deflected jet flow (i.e. "momentum-dominated far-field", mdff) is then expressed in terms of the jet/crossflow length scale

$$z/L_m = t_2(x/L_m)^{1/3} \quad (2.20)$$

where t_2 is a trajectory constant.

The width b of the gradually rising jet element is proportional to the height of rise z

$$b = b_2 z \quad (2.21)$$

where b_2 is a spreading constant.

The mass conservation equation is used to determine the dilution at any position z , $c_0 Q_0 = c_f b^2 u_a$. In terms of the jet/crossflow length scale the dilution is expressed as

$$S = s_2(z^2/L_m L_0) \quad (2.22)$$

where s_2 is a dilution constant for the mdff flow.

2.1.4.3 Weakly Deflected Plume in Crossflow

For a relatively weak crossflow, the pure plume would behave the same as if it were in a stagnant environment, except that it is advected with the ambient current (Figure 2.4c).

For values of $z/L_b \ll 0(1)$, the flow will behave as a plume in a stagnant environment but will be advected with the crossflow. Proceeding in analogy to the mdnf flow, the trajectory equation for the weakly deflected plume flow (i.e. "buoyancy-dominated near-field", bdnf) can be written in terms of the plume/crossflow length scale

$$z/L_b = t_3(x/L_b)^{3/4} \quad (2.23)$$

where t_3 is a trajectory constant.

Plume width b is similar to the plume issued in a stagnant environment and is given by

$$b = b_3 z \quad (2.24)$$

where b_3 is a spreading constant.

The dilution S is similar to Eq. (2.8), and is expressed in terms of L_b , L_c , and L_m

$$S = s_3(L_b^{1/3} z^{5/3}) / (L_c L_m) \quad (2.25)$$

where s_3 is the dilution constant for the bdnf flow.

2.1.4.4 Strongly Deflected Plume in Crossflow

For $z/L_b \gg 0(1)$ the ambient flow will have a pronounced effect on the flow pattern. When strongly deflected, the plume vertical velocity has decayed to less than the value for the ambient crossflow; the ambient crossflow will have significantly deflected the plume as shown in Figure 2.4c.

The deflected plume should behave as a rising thermal, i.e. an instantaneous release of a buoyant cylindrical fluid mass along a line source. The important variables are J' , the buoyant weight per unit length, vertical rise z , and time t . Dimensional reasoning implies for the thermal

$$J' t^2 / z^3 = \text{constant} \quad (2.26)$$

Substituting x/u_c for t and replacing J' by J_0/u_c yields the trajectory relationship for the strongly deflected plume flow (i.e. "buoyancy-dominated far-field", bdff) expressed in terms of length scales

$$z/L_b = t_4(x/L_b)^{2/3} \quad (2.27)$$

where t_4 is a trajectory constant.

Plume width b is analogous to Eq. (2.21), or

$$b = b_4 z \quad (2.28)$$

where b_4 is a spreading constant.

The mass conservation equation is used to determine the dilution at any position z , $c_0 Q_0 = cb^2 u_c$, leading to

$$S = s_4 z^2 / (L_0 L_m) \quad (2.29)$$

in analogy to Eq. (2.22), where s_4 is a dilution constant for the bdf flow.

2.1.4.5 Horizontal Jet with Vertical Buoyant Deflection

For a horizontally discharging jet with weak vertical deflection induced by the buoyancy the centerline velocity is given in first order by the pure jet solution, Eq. (2.3), or $u_c = M_0^{1/2} x^{-1}$ in which x is the horizontal coordinate direction. The small vertical deflection due to the local buoyancy-induced velocity w is given by

$$dz/dx = w/u_c \quad (2.30)$$

The local buoyant vertical acceleration of a jet element is given by

$$dw/dt = J_0 / (a u_c) \quad (2.31)$$

in which $a = b^2$ is the local jet cross-sectional area and $b = x$ is the jet width. With the Galilean transformation $dt = dx/u_c$, and after substitution for b and u_c , Eqs. (2.30) and (2.31) can be solved to give the normalized trajectory relation

$$z/L_m = t_5(x/L_m)^3 \quad (2.32)$$

The appropriate width and dilution equations are

$$b = b_5 x \quad (2.33)$$

and

$$S = s_5(x/L_0) \quad (2.34)$$

where the constants b_5 and s_5 should be numerically similar to those for the weakly deflected jet in crossflow, $b_5 \approx b_1$, and $s_5 \approx s_1$, respectively. In either case the perturbation effects are small and the equations must be identical if no perturbation is present. The above solutions are valid in the region $x/L_M \ll O(1)$.

2.1.4.6 Vertical Plume with Horizontal Momentum Deflection

The final phase of a horizontal buoyant jet will be a vertically rising plume which is weakly deflected by the effect of the horizontal discharge momentum (see Fig. (2.4a)). This will occur in the region $z/L_M \gg O(1)$. The plume will have a local vertical centerline velocity given in first order by the pure solution, Eq. (2.6). The small horizontal deflection of the plume trajectory is given by

$$dx/dz = u_h/u_c \quad (2.35)$$

where u_h is the induced horizontal velocity due to the discharge momentum flux M_0 . Conservation of horizontal impulse implies

$$a u_h \approx M_0/u_c \quad (2.36)$$

in which $a \approx b^2$ is the local plume cross-sectional area and $b \approx z$ is the plume width. The trajectory relation is obtained after substitution and integration

$$x/L_M = x_f - t_6(z/L_M)^{-1/3} \quad (2.37)$$

in which x_f is the ultimate value of the horizontal deflection for the final stage (as z approaches infinity) of the vertically rising plume. The width and dilution are given directly by Eqs. (2.7) and (2.8), or using the appropriate length scales,

$$b = b_6 z \quad (2.38)$$

and

$$S = s_6 z^{5/3} / (L_M^{2/3} L_0) \quad (2.39)$$

As before, the constants b_6 and s_6 should be the same as those for the weakly deflected plume, $b_6 \approx b_3$ and $s_6 \approx s_3$, respectively.

The buoyant trajectory equations for the horizontal buoyant jet in a stagnant environment, Eqs. (2.32) and (2.37), are similar to those first derived by Abraham (1963), albeit with a different methodology.

2.2.4.7 Vertical Jet in Linear Stratification

A vertically discharging jet in a linear ambient density environment will, in its initial stage, behave purely jet-like. In the final stage, however, as it approaches the terminal level, it will be increasingly modified by the ambient density gradient. In particular the local jet momentum flux, $M \approx u_c^2 b^2$, and local buoyancy flux, $J \approx u_c g_c' b^2$, where g_c' is the local centerline buoyancy ($g_c' = g(\rho_s(z) - \rho_c)/\rho_s(z)$, where ρ_c is the centerline density and $\rho_s(z)$ is the local ambient density), will change.

The conservation equations are

$$dM/dz \approx g_c' b^2 \approx bJ/M^{1/2} \quad (2.40)$$

for momentum and

$$dJ/dz \approx -Q\varepsilon \approx -M^{1/2} b\varepsilon \quad (2.41)$$

for buoyancy, in which $Q \approx u_c b^2$ is the local jet discharge (volume flux) and ε is the linear buoyancy gradient. In addition, a linear jet spreading equation applies in first order

$$db/dz \approx k \quad (2.42)$$

where k is the spreading coefficient. Integration of these three equations with the boundary conditions $b = 0$ (point source), $M = M_0$, and $J = 0$ (pure jet discharge) at $z = 0$ leads to the solution

$$M/M_0 = 1 - m_7(z/L_m')^4 \quad (2.43)$$

where m_7 is an appropriate constant. Eq. (2.43) indicates that for $z/L_m' \ll 0(1)$ the jet momentum is essentially conserved, $M = M_0$ (pure jet), while the terminal level is approached at a height, $Z_t/L_m' = (1/m_7)^{1/4}$, at which point the local jet momentum vanishes, $M = 0$. Other aspects of the solution are the linear spread

$$b = b_7 z \quad (2.44)$$

and the dilution

$$S = s_7((1 - m_7(z/L_m')^4))^{1/2} z/L_0 \quad (2.45)$$

where the constants b_7 and s_7 should be similar to those of the pure jet, $b_7 \approx b_1$, and $s_7 \approx s_1$.

No similar closed-form solutions seem possible for cases with a discharge buoyancy (non-zero J_0) including the limiting case of a pure plume.

2.2 Buoyant Spreading Processes

In the context of this study, buoyant spreading processes are defined as the horizontally transverse spreading of the mixed effluent flow while it is being advected downstream by the ambient current. Such spreading processes arise due to the buoyant forces caused by the density difference of the mixed flow relative to the ambient density.

The buoyant spreading phenomenon is a far-field mixing process. Usually it is preceded by buoyant jet mixing in the near-field and is followed by passive diffusion, another far-field mixing process. If the discharge is nonbuoyant, or weakly buoyant, and the ambient is unstratified, there is no buoyant spreading region in the far-field, only a passive diffusion region.

Depending on the type of near-field flow and ambient stratification several types of buoyant spreading may occur: (i) spreading at the water surface, (ii) spreading at the bottom, (iii) spreading at a sharp internal interface (pycnocline) with a density jump, or (iv) spreading at the terminal level in continuously (e.g. linearly) stratified ambient.

2.2.1 Buoyant Surface Spreading

The definition diagram and structure of a surface buoyant spreading process in unstratified crossflow is shown in Figure 2.5. The laterally spreading flow behaves like a density current and entrains some ambient fluid in the "head region" of the current. The mixing rate is usually relatively small. Furthermore, the flow may interact with a nearby bank or shoreline (not shown in Figure 2.5). The flow depth may decrease during this phase. The analysis of this region is based on arguments presented for surface buoyant spreading by Jones et al. (1985).

The continuity equation for the density current is

$$u_s \partial b_v / \partial x + \partial (v b_v) / \partial y = w_s \quad (2.46)$$

where w_s is the net velocity across the interface, u_s is the ambient current, $v(x,y)$ is the local transverse velocity, b_v is the vertical density current thickness, x is the

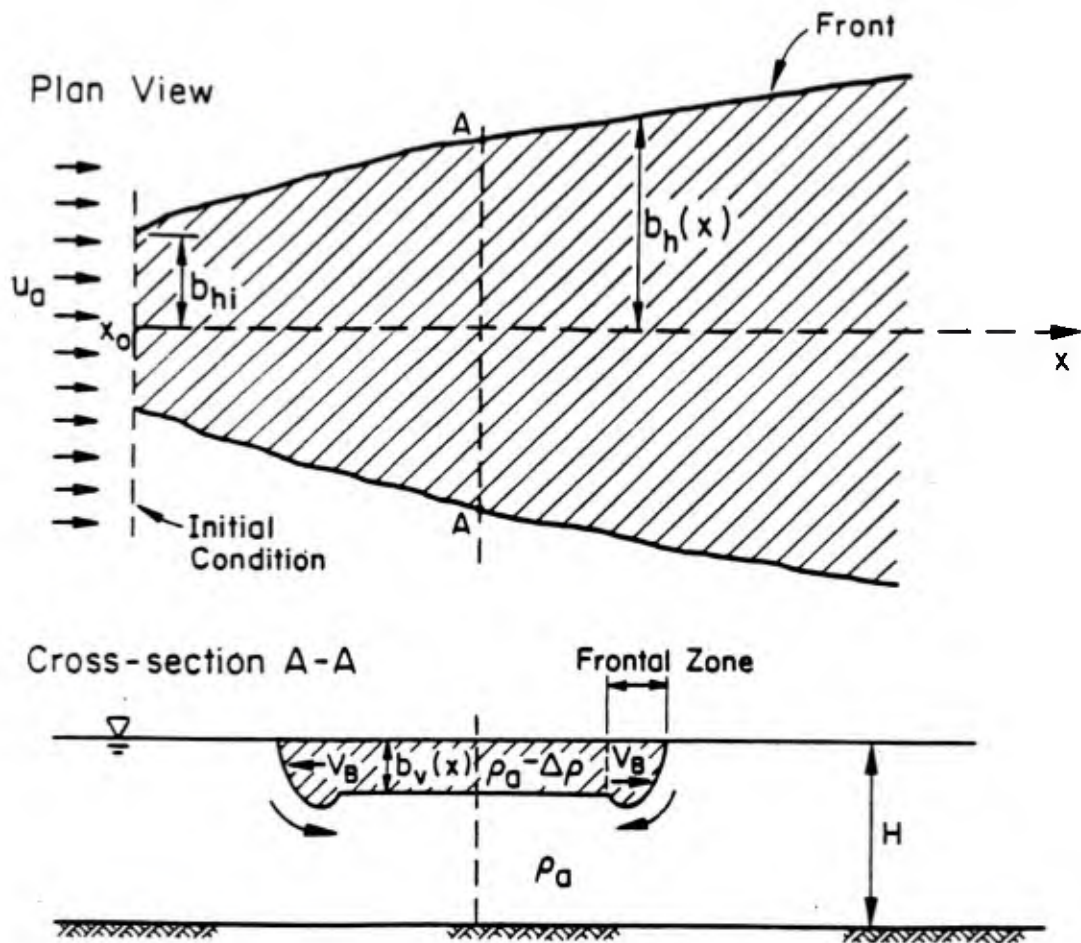

Buoyant Surface Spreading

Figure 2.5 Buoyant Surface Spreading Process

downstream distance, and y is the distance lateral to the crossflow. Benjamin (1967) has derived an equation for the spreading velocity v_s

$$v_s^2 / (g' b_v) = 1 / C_D \quad (2.47)$$

where C_D is a drag coefficient that depends on the relative depth b_v/H and is in the range of 1/2 to 2. Combining Eqs.

(2.46) and (2.47) and integrating laterally over the density current width gives

$$u_s d(b_v b_h) / dx = q_e(x) \quad (2.48)$$

where $q_e(x)$ is the localized head entrainment representative of the dominant mixing mechanism, and b_h is the lateral half-width.

The localized head entrainment of the density current is parameterized as $q_e(x) = \beta v_s b_v$ where β is a constant with a range of 0.15 to 0.25 (Simpson and Bitter, 1979; Jirka and Arita, 1987).

The flow half-width b_h is obtained for any downstream distance x by using the boundary condition for the streamline ($v_s = u_s db_h / dx$) and integrating Eq. (2.46)

$$b_h = [b_{hi}^{3/2} + 3/2 (L_v / 2 C_D)^{1/2} (x - x_i)]^{2/3} \quad (2.49)$$

where x_i is the downstream distance at the beginning of the buoyant spreading region, and b_{hi} is the initial density current half-width. This 2/3 power law of flow spreading is in agreement with the previous work of Larsen and Sorensen (1968).

The vertical flow width b_v is given by integrating Eq. (2.48) to obtain

$$b_v = b_{vi} (b_h / b_{hi})^{\beta-1} \quad (2.50)$$

Due to mixing the local concentration c and local buoyancy g' gradually change with distance x . The bulk dilution S , given by c_0/c , is equivalent to the ratio g_0'/g' of buoyancy which is a conservative tracer in this case. Buoyancy conservation in the density current can be expressed as $u_s g' b_v b_h = \text{constant}$. The initial conditions and appropriate substitutions provide the expression for dilution S

$$S = S_i (b_h / b_{hi})^\beta \quad (2.51)$$

where S_i is the initial dilution.

2.2.2 Buoyant Bottom Spreading

This spreading process is analogous to the surface spreading (Figure 2.5) except that the mixed flow density is $\rho_s + \Delta\rho$, i.e. heavier than the ambient. If bottom friction is neglected in the spreading process, then the same equation system as derived above will apply.

2.2.3 Buoyant Spreading at Pycnocline

Referring to Figure 2.6a, a sharp density change may exist separating an ambient lower layer with density ρ_L and an upper layer with density ρ_U . A mixed zone may exist as a result of a near-field mixing process. The mixed zone density is $\rho_L - \Delta\rho$, so that a difference $\Delta\rho$ exists relative to the lower layer. If the local (at any x) thickness of the density current is b_v , then this region extends for hydrostatic reasons partially over the upper layer, so the expression for h_u is

$$h_u = b_v \Delta\rho / (\rho_L - \rho_U) \quad (2.52)$$

and partially over the lower layer, so that $h_l = b_v - h_u$. Other than this hydrostatic adjustment mechanism the buoyant spreading process at the pycnocline has the same flow equations, i.e. Eqs. (2.49, 2.50, 2.51), as the buoyant surface current.

2.2.4 Buoyant Spreading at Terminal Level

In an ambient stratification with a linear density gradient, a near-field mixing process may lead to a layer formation at a terminal level Z_t , i.e. a mixed current is produced whose density is equal to the ambient density at the terminal level. The mixed zone perturbs the ambient stratification as shown in Figure 2.6b and leads to a lateral spreading while the flow is being advected downstream, qualitatively similar to Figure 2.5.

The spreading velocity v_s for the stratified case is expressed as

$$v_s^2 / (\epsilon b_v^2) = 1 / (2C_D) \quad (2.53)$$

where C_D is the drag coefficient for the stratified case.

Proceeding in the same fashion as in Section 2.21 gives the following results, for horizontal half-width b_h

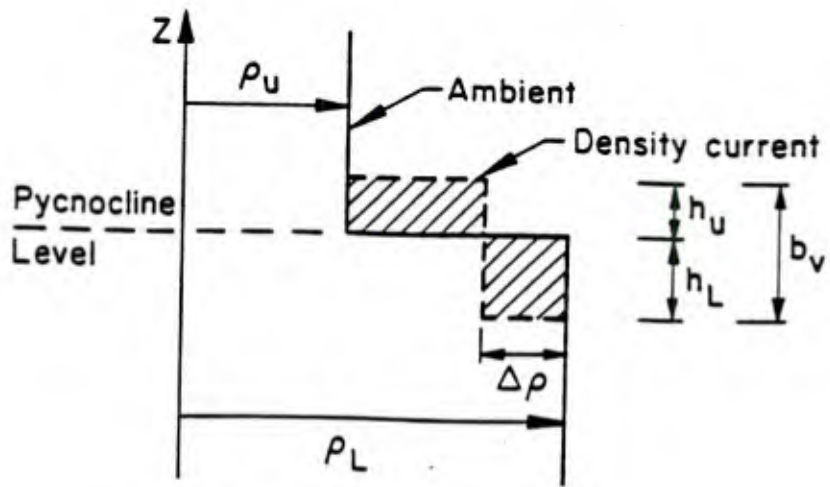

a) Spreading at Pycnocline

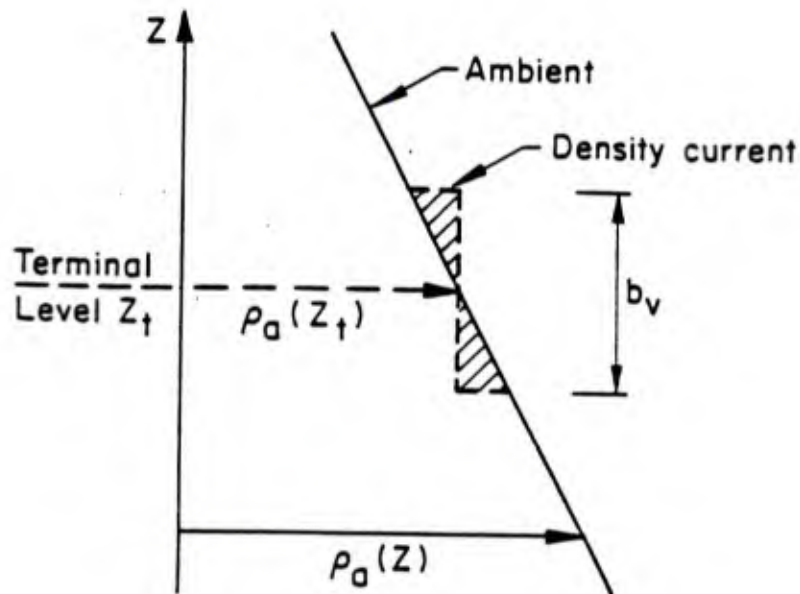

b) Spreading at Terminal Level of Linear Stratification

Figure 2.6 Density Perturbation of Ambient Stratification Leading to Buoyant Spreading Processes

$$b_h = [b_{hi}^{2-\beta} + (2-\beta)(2C_D)^{-1/2}L_m/L_m'^2 b_{vi}/b_{hi}^{\beta-1}(x-x_i)]^{1/(2-\beta)} \quad (2.54)$$

while the expression for the vertical thickness b_v is

$$b_v = b_{vi}(b_h/b_{hi})^{\beta-1} \quad (2.55)$$

Dilution is given by continuity as

$$S = S_i(b_h/b_{hi})^\beta \quad (2.56)$$

2.3 Passive Ambient Diffusion Processes

The existing turbulence in the ambient environment becomes the dominating mixing mechanism at sufficiently large distances from the discharge point. The intensity of this passive diffusion process depends upon the geometry of the ambient shear flow as well as any existing stratification. In general, the passively diffusing flow is growing in width and in thickness (see Figure 2.7). Furthermore, it may interact with the channel bottom and/or banks.

The analysis of this region follows classical diffusion theory (e.g. Fischer, et al. 1979). The standard deviation σ of a diffusing plume in crossflow can be written in terms of the transverse turbulent diffusivity E

$$\sigma^2 = 2Ex/u_s \quad (2.57)$$

in which x is the distance following the ambient flow with the point release located at $x = 0$. The coefficient of eddy diffusivity depends on the turbulence conditions in the environment and may be a function of distance x (or plume size σ).

2.3.1 Diffusion in Unbounded Channel Flow

In open channel flow the eddy diffusivity can be related to the friction velocity u_s and the channel depth H

$$E_z = 0.2u_s H \quad (2.58)$$

for vertical diffusivity, and

$$E_y = 0.6u_s H \quad (2.59)$$

for horizontal diffusivity. The friction velocity is given

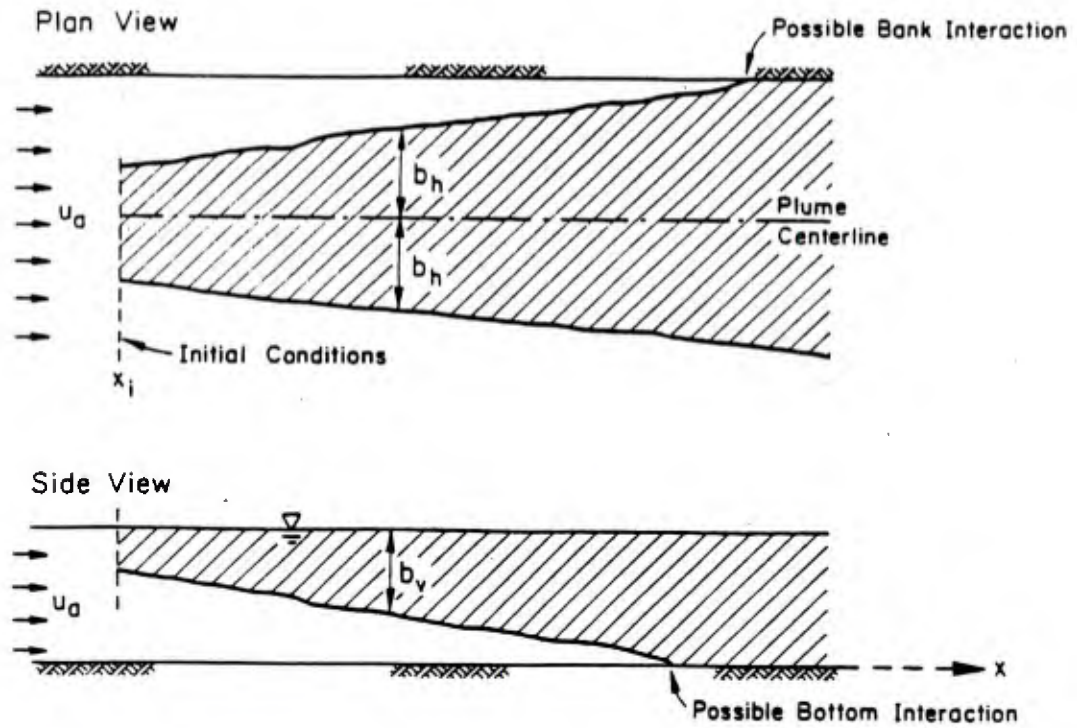

Passive Diffusion Process

Figure 2.7 Passive Ambient Diffusion Process

by $u_* = (f/8)^{1/2} u_*$, where f is the Darcy-Weisbach friction factor. Due to some anisotropy in a typical channel flow, the diffusivity in the horizontal transverse direction is usually larger than the diffusivity in the vertical direction. The coefficients included in Eqs. (2.58) and (2.59) are average values for reasonably uniform channels. The coefficients may be considerably larger (up to a factor of 2) for highly non-uniform cross-sections and/or strongly curved channels (see also Holley and Jirka, 1986).

Solution of Eq. (2.57) with these diffusivities and with initial flow width conditions specified at x_i (see Figure 2.7) gives the vertical thickness b_v and half-width b_h , respectively

$$b_v = [\pi E_z(x-x_i)/u_* + b_{vi}^2]^{1/2} \quad (2.60)$$

$$b_h = [\pi E_y(x-x_i)/u_* + b_{hi}^2]^{1/2} \quad (2.61)$$

where x_i , b_{vi} , and b_{hi} are the distance, half-width, and depth of the plume, respectively, at the beginning of the passive diffusion region. The above lengths are related to the standard deviations, $b_v = (\pi/2)^{1/2} \sigma_z$ and $b_h = (\pi/2)^{1/2} \sigma_y$, and assume an equivalent top-hat plume with same centerline concentration and pollutant mass flux.

The continuity equation applied to the plume in crossflow $2u_*b_vb_h \approx SQ_0$ yields the dilution

$$S = 2b_vb_h/(L_mL_0) \quad (2.62)$$

Beyond the distance when the flow becomes fully mixed ($b_v = H$), the dilution expression is

$$S = 2Hb_h/(L_mL_0) \quad (2.63)$$

2.3.2 Horizontal Diffusion in Unbounded Channel Flow

Many environmental flows without any significant limitation on the transverse dimension (coastal water, large lakes, etc.) exhibit an accelerating turbulent diffusive growth pattern. The horizontal diffusivity is often specified by the so called "4/3 law" (see Fischer et al., 1979)

$$E_y = \alpha(3\sigma_y)^{4/3} \quad (2.64)$$

in which α is a coefficient equal to $0.01 \text{ cm}^{2/3}/\text{s}$ (appropriate for small plume sizes) and E_y is in units of $[\text{cm}^2/\text{s}]$ and σ_y in $[\text{cm}]$. Integration of the applicable diffusion equation with this variable E_y yields a solution

for plume growth (Brooks, 1960, see also Fischer et al., 1979)

$$b_h = b_{hi} [1 + (\pi/3) E_{yi} (x-x_i) / (u_s b_{hi}^2)]^{3/2} \quad (2.65)$$

in the present notation and width convention. E_{yi} is the initial value of diffusivity, so from Eq. (2.64) at position x_i

$$E_{yi} = 0.0015 b_{hi}^{4/3} \quad (2.66)$$

with units of $[m^2/s]$ for E_{yi} and $[m]$ for the initial width b_{hi} . The dilution expressions are the same as before, given by Eqs. (2.63) and (2.62).

2.3.3 Vertical Diffusion in Stratified Shear Flow

In the presence of a stable ambient stratification the vertical diffusive mixing is generally inhibited. An expression proposed by Munk and Anderson (1948) can be used to specify the reduced vertical diffusivity

$$E_z = E_o (1 + 3.33 R_i)^{-1.5} \quad (2.67)$$

in which E_o is the vertical diffusivity under neutral shear flow conditions (given by Eq. (2.59)) and R_i is the gradient Richardson number. For linearly stratified shear flow with a layer depth H_s , a simple expression for the gradient Richardson number is

$$R_i = \epsilon \kappa^2 H_s^2 / u_s^2 \quad (2.68)$$

where ϵ is the buoyancy gradient, κ is the von Karman constant (≈ 0.4), and u_s is the shear velocity.

2.4 Interaction Processes: Surface or Bottom Boundaries, and Internal Layer Formation

Ambient water bodies always have vertical boundaries: the water surface and the bottom, but in addition "internal boundaries" may exist in the form of layers of rapid density changes (pycnoclines). Depending on the dynamic and geometric characteristics of the discharge flow, a large number of interaction phenomena can occur at such boundaries. Furthermore, in the case of a linearly stratified ambient where flow trapping may occur, other interaction phenomena may take place.

In essence, these interaction processes provide a transition between the jet mixing process in the near-field

(Section 2.1), and between buoyant spreading (Section 2.2) and passive diffusion (Section 2.3) in the far-field.

The analysis of several interaction processes is presented in the following sections. Many other situations are possible depending upon discharge configuration, direction of buoyancy and other factors; however all of these are related to the generic cases and they will be briefly summarized (without analysis) in Chapter V.

A control volume approach is used for the following sections. When the flow contacts the boundary, b_v and b_h are defined as the vertical depth and horizontal half-width of the subsequent flow, respectively. The variable subscripts "i" (initial) and "f" (final) (e.g. b_i , S_f) denote control volume inflow and outflow quantities, respectively.

2.4.1 Near-Horizontal Surface Approach

In the surface approach the bent over flow approaches the water surface near horizontally at impingement angle $\theta_i < 45^\circ$ (Figure 2.8a). The flow is advected with the ambient velocity field at a rate equal to u_a . This situation occurs for crossflow dominated jet-like and plume-like cases that are relatively weakly buoyant, hence the flow will be strongly deflected when it contacts the surface.

Experimental evidence (Jirka and Harleman, 1973) suggests that within a short distance after surface impingement the concentration distribution for a 2-D flow changes from the assumed gaussian distribution to a top-hat or uniform distribution (Figure 2.8a). Using a control volume approach the initial centerline dilution is related to the final bulk dilution, and a bulk mixing process is assumed with $S_f = cS_i$, where c is of the order of 1.5 to 2.0. An equivalent cross-section aspect ratio for the outflow section of 2:1 is assumed. The continuity equation for the control volume in Figure 2.8a is then

$$S_f Q_0 = u_a 2b_{hf} * b_{vf} \quad (2.69)$$

where b_i is the initial half-width (radius), b_{vf} is the final flow vertical width, and b_{hf} is the final flow horizontal half-width. This is evaluated as $b_{vf} = b_{hf} = (S_f L_m L_0 / 2)^{1/2}$.

A dynamically analogous situation exists for the bottom approach of a downward oriented jet or negatively buoyant flow. Also the approach process to any internal pycnoclines is quite similar, even though the layer configuration will adjust itself hydrostatically along the pycnocline depending on the density jump conditions (see Section 2.2.3 and Figure

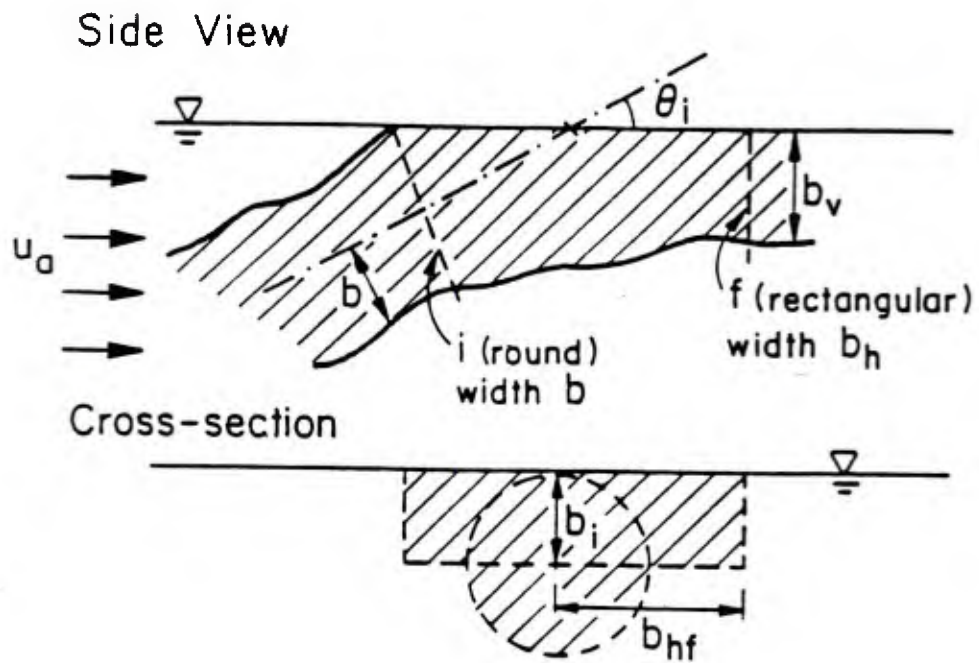

a) Surface Approach (Near-Horizontal)

Figure 2.8 Flow Interaction Process with Water Surface (i indicates inflow values in control volume and f outflow values)

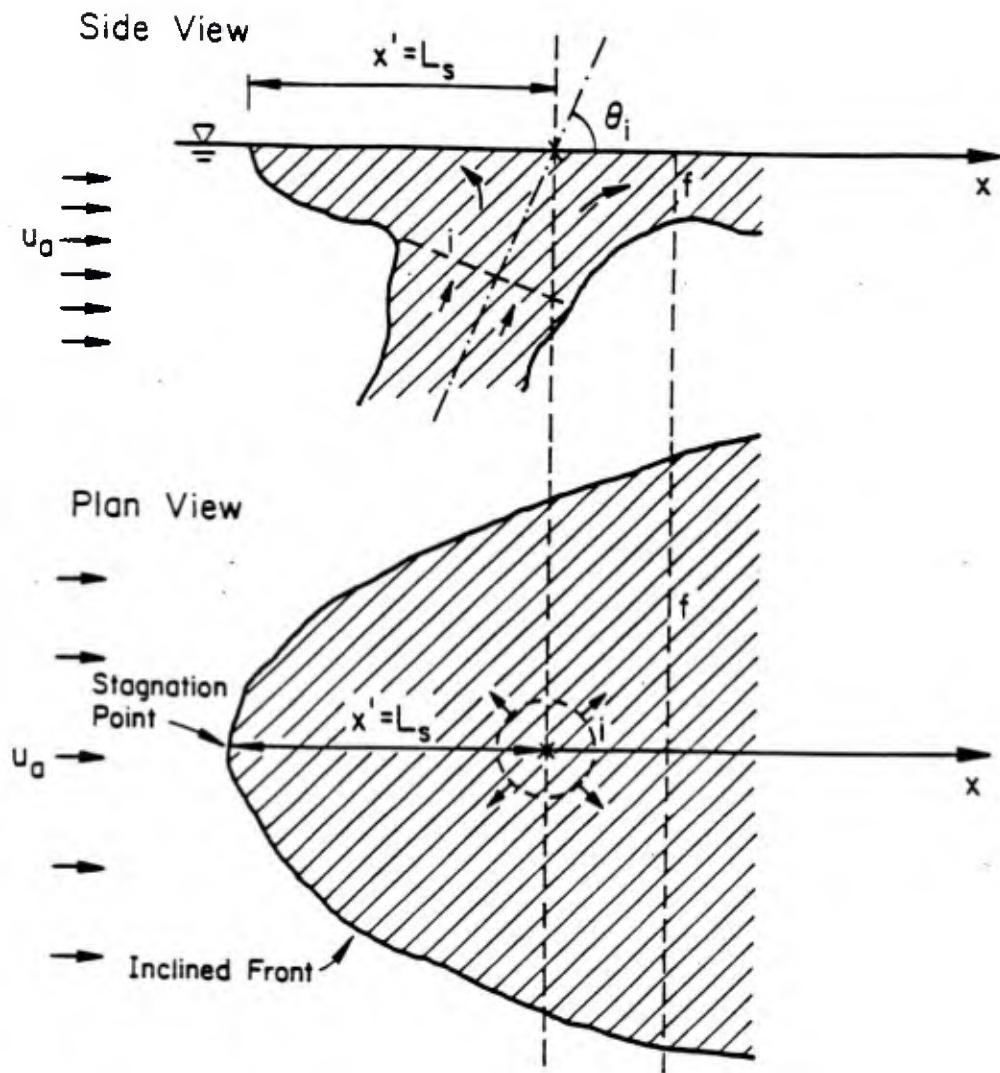

b) Surface Impingement with Buoyant Upstream Spreading

Figure 2.8 (continued)

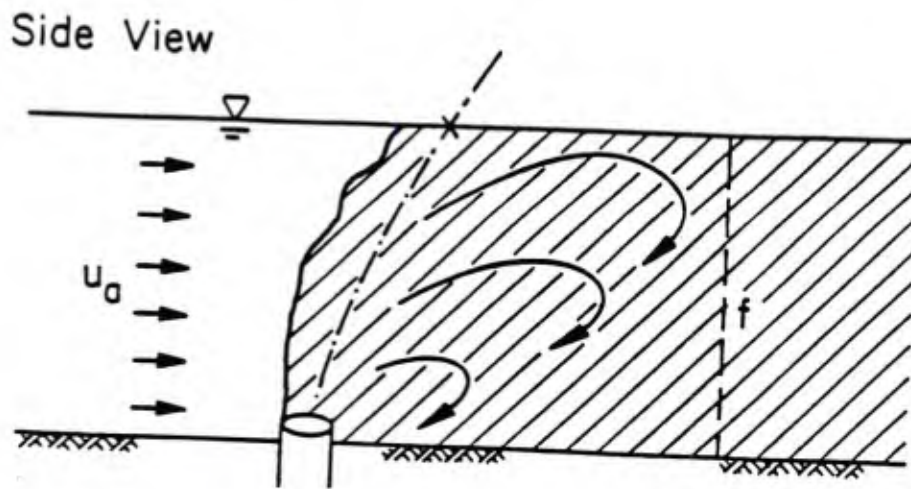

c) Surface Impingement with Full Vertical Mixing

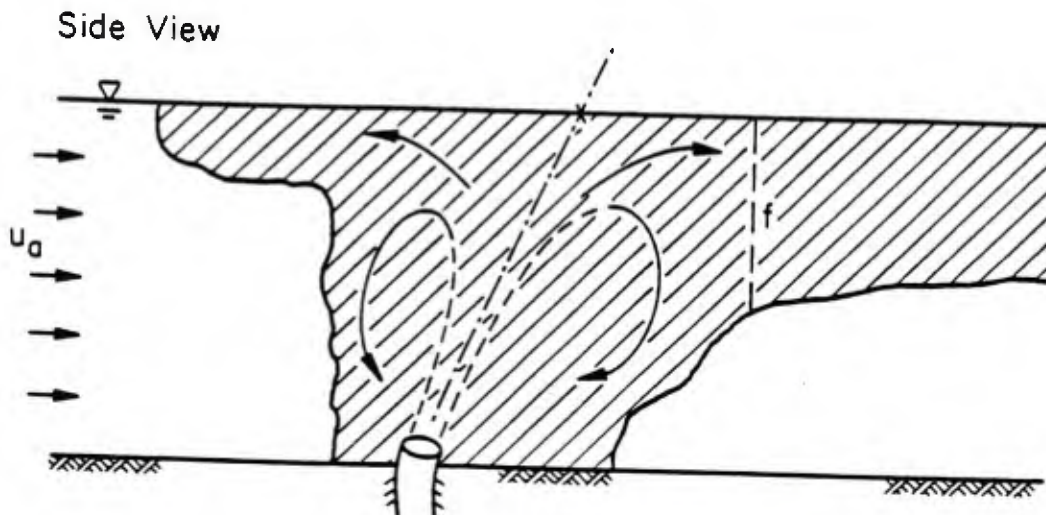

d) Surface Impingement with Buoyant Upstream Spreading, Full Vertical Mixing, and Buoyant Restratification

Figure 2.8 (continued)

2.6a). Finally the near-horizontal approaches towards the terminal layer in continuously stratified flow will be analyzed with a similar approach.

2.4.2 Near-Vertical Surface Impingement with Buoyant Upstream Spreading

In this surface approach condition, the weakly bent flow impinges on the surface at a near-vertical angle θ_i (Figure 2.8b), where $\theta_i > 45^\circ$. After impingement the flow spreads more or less radially along the water surface as a density current. In particular, the flow spreads some distance upstream against the ambient flow, and laterally across the ambient flow. This spreading is dominated by the strong buoyancy of the discharge.

The lateral spreading of the flow in the surface impingement region is driven by both the flow momentum and buoyancy force. Of interest is the upstream intrusion length L_s , dilution S , horizontal width b_h , and vertical depth b_v of the density current at surface impingement.

The analysis of this flow region follows results presented by Lee and Jirka, (1981), and Jones et al., (1983). Lee and Jirka analyze the properties of a buoyant subsurface discharge in stagnant water including the effects of recirculation and buoyant restratification. Jones et al. presents a methodology to predict the upstream spreading of a buoyant radial discharge in crossflow.

A length scale L_N representing the turbulent mixing action of the horizontal momentum flux versus stability effect of buoyancy force is given by

$$L_N = (\text{deflected horizontal momentum flux})^{3/4} / J_0^{1/2} \quad (2.70)$$

For the weakly deflected plume, Holley and Jirka, (1986) give an expression for the vertical momentum of a plume

$$M = 0.85J_0^{2/3} z^{4/3} \quad (2.71)$$

where, z ($\approx H$) is the vertical distance along the flow trajectory. Substituting appropriate values into Eq. (2.70), the length scale for a weakly deflected plume at impingement becomes

$$L_N \approx 0.367H(1-\cos\theta_i) \quad (2.72)$$

where the factor $(1-\cos\theta_i)$ accounts for the deflected horizontal momentum flux, in analogy to the vane equation in classical fluid mechanics.

Jones et al. define an intrusion length scale L_1 , by the interaction of buoyancy force with the crossflow force

$$L_1 = J_0 / (2\pi c_D u_s^3) \quad (2.73)$$

where c_D is a drag coefficient of $O(1)$.

Thus, for a weakly deflected plume at surface approach, the ratio of length scales obtained from Eqs. (2.72) and (2.73)

$$L_1/L_N \approx 0.54 (L_b/H) (1/(1-\cos\theta_i)) \quad (2.74)$$

which describes the relative importance of buoyancy to momentum forces at surface impingement.

Jones et al. provide a numerical solution for the upstream intrusion length (their Figure 5-14) which can be summarized as follows

$$L_s/L_1 = 4.2 (L_1/L_N)^{-2/3} \quad \text{for } L_1/L_N \leq 3.3 \quad (2.75)$$

$$L_s/L_1 = 1.9 \quad L_1/L_N > 3.3 \quad (2.76)$$

Noting that $L_1 \approx L_b/5$ with $c_D \approx 1$ and since the flow is a weakly deflected plume at surface approach, the upstream intrusion length L_s in Eq. (2.75) can be expressed in the present notation as

$$L_s = 1.26 L_b ((1-\cos\theta_i)/(L_b/H))^{2/3} \quad (2.77)$$

$$L_s = 1.9 L_b \quad (2.78)$$

for the conditions $L_b/H \leq 6.11(1-\cos\theta_i)$ and $L_b/H > 6.11(1-\cos\theta_i)$ in Eqs. (2.75) and (2.76), respectively.

Jones et al. (their Figure 7-8) also give the dilution for a radial surface discharge

$$S/F_s = 1.6 (L_1/L_N)^{1/3} \quad (2.79)$$

where F_s is a radial surface spreading Froude number. This Froude number is defined as

$$F_s = u_r / (g' L_0)^{1/2} \quad (2.80)$$

where u_r is the discharge velocity of the radial jet and L_0 is a characteristic length scale defined by

$$L_0 = (2\pi r_1 h_1)^{1/2} \quad (2.81)$$

with r_1 and h_1 are the radius and depth of the buoyant radial surface spreading flow, respectively.

The results of Lee and Jirka can be used to evaluate the surface spreading Froude number F_s , so the dilution S from Eq. (2.79) can be found. In this analysis, the initial radial surface spreading region uses a simplified control volume to relate the properties of the vertically buoyant jet at the entrance of the surface impingement region to the characteristic parameters of the horizontal axisymmetric buoyant surface jet at the exit of this region.

Lee and Jirka define the Froude number at surface impingement

$$F_i = u_r / (g' h_i)^{1/2} \quad (2.82)$$

where u_r is the radial surface spreading velocity and h_i is the depth after impingement. For large values of H/D , the value $F_i \approx 4.62$ and the value $h_i/H \approx 0.0775$. The radius of the flow r_i is $r_i \approx \epsilon H$, where $\epsilon \approx 0.11$. By substituting these asymptotic values into Eq. (2.81), the characteristic length scale L_o becomes

$$L_o \approx 0.23H \quad (2.83)$$

which when combined with asymptotic values for Eq. (2.82) gives

$$F_s = F_i (h_i / L_o)^{1/2} \approx 2.65 \quad (2.84)$$

indicating that the flow in this region is jet-like. Finally, note that the radial surface spreading Froude number F_s can be expressed in terms of the discharge flux variables as $QJ_0^{1/2} / M_0^{5/4}$.

This result can be then used to determine a bulk dilution at the end of the region S_f . From Eqs. (2.79) and (2.84) the expression for final dilution in the surface impingement region is

$$S_f = 3.49 S_i (L_o / H)^{1/3} (1 - \cos \theta_i)^{-1/3} \quad (2.85)$$

The geometry of the surface flow as computed by Jones et al. will be used to determine the width and depth within the region. From Jones et al. (their Figure 7.1), the width, b_{hf} , at impingement is about 2.6 times larger than L_s , or

$$b_{hf} = 2.6 L_s \quad (2.86)$$

The typical depth of the flow in the upstream intrusion region h_s , is found using the vertical length scale from Jones et al. where

$$h_s = c_0 u_s^2 / g' \quad (2.87)$$

with $c_0 = 0.8$. With the definition $g' = g_0' / S_f$, where S_f is the total bulk dilution, and using the identity $u_s^2 Q_0 / J_0 = u_s^3 Q_0 M_0^{1/2} / (J_0 u_s M_0^{1/2}) = L_0 L_m / L_b$, the stagnation flow thickness h_s is

$$h_s = 0.8 S_f L_m L_b / L_b \quad (2.88)$$

The final depth b_{vf} (at $x=0$) is found using again the continuity equation, $b_{vf}(x=0) = Q_0 S_f / (2b_{hf} u_s)$, leading to

$$b_{vf} = S_f L_m L_b / (2b_{hf}) \quad (2.89)$$

2.4.3 Near-Vertical Surface Impingement with Full Vertical Mixing

In this surface approach region, the weakly bent flow impinges on the water surface at a near-vertical angle (Figure 2.8c). Given a shallow ambient water depth and a weak buoyancy of the discharge, the flow may become unstable after impingement, and may recirculate.

The recirculation region causes the flow to entrain ambient fluid from the flow itself causing dilution within the flow to decrease. Because of unstable recirculating flow, the centerplane dilution increases to $S_f = R S_i$, where R is a mixing factor. Experimental data indicate R ranges from 1.0 to 4.0. The final flow width, b_{hf} , is found from the continuity equation

$$b_{hf} = S_f L_m L_b / (2H) \quad (2.90)$$

and final outflow location x_f is approximated as

$$x_f = x_i + H \quad (2.91)$$

where x_i is the flow position at the beginning of the region. The additional distance H accounts for the typical length of a recirculating zone.

For more buoyant yet unstable discharges, the full vertical mixing in the near-field can occur in combination with upstream spreading as discussed in Section 2.4.2. This is illustrated in Figure 2.8d.

2.4.4 Bottom Interaction Processes

A submerged buoyant jet discharging in the vicinity of the water bottom into a stagnant or cross-flowing ambient can experience two types of dynamic interaction processes

that lead to rapid attachment of the effluent plume to the water bottom (see Figure 2.9). These may be wake attachment forced by the crossflow or Coanda attachment forced by the entrainment demand of the effluent jet itself. A physical description of these processes is given below. Appropriate criteria for the occurrence of such attachment processes are discussed in Chapter III.

2.4.4.1 Wake Attachment

In wake attachment (Figure 2.9a), the presence of the discharge outfall structure and the jet efflux interrupts the ambient velocity field and causes a recirculation region in the wake downstream from the discharge.

The appropriate length scale measuring the outfall structure/jet efflux combination is given by $L_0 = (h_0 L_b)^{1/2}$ where h_0 is the port height or by $L_0 = L_b$ for a flush discharge (zero port height). The downstream extent X_R of the recirculation region is a few multiples of L_0 ,

$$X_R = CL_0 \quad (2.92)$$

where $C \approx 5.0$. Furthermore, in many such recirculation processes the dilution is limited to low values, $S_R \approx 2.0$ to 4.0 (see Jirka et al., 1975). Thus by continuity the width of the attached (semi-circular) cross-section at the end of the recirculation zone is given by

$$b_R = [(2/\pi) S_R L_m L_0]^{1/2} \quad (2.93)$$

with virtual source conditions assumed for the discharge.

A wall jet, with initial width b_R , is formed downstream from the recirculation region. If boundary friction in that wall jet is neglected - a reasonable assumption as indicated by the data summarized in Rajaratnam, 1976 - then the dynamics of the attached wall jet are similar to those of the free jet as discussed earlier. Further details of such jet models are presented in Chapter V.

Depending on discharge buoyancy, the wall jet may adhere to the bottom for long distances (weak, zero or negative buoyancy) or it may lift-off from the bottom at some distance (strong positive buoyancy). Such possibilities are considered in the classification scheme in Chapter III.

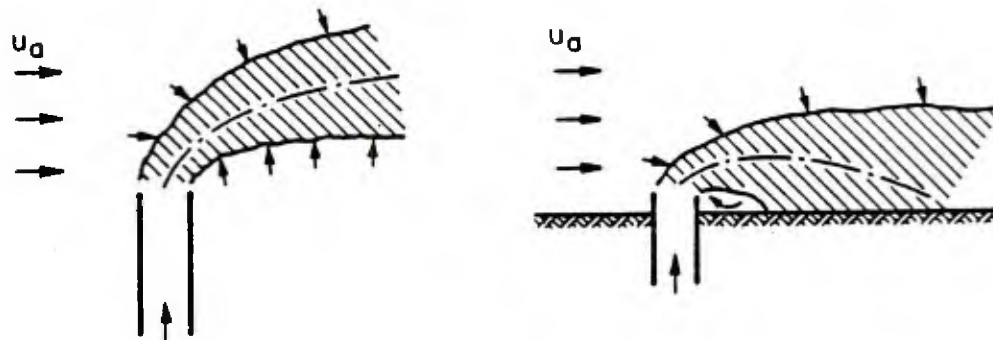

i) Free Deflected Jet/Plume
in Cross-flow

ii) Wake Attachment of
Jet/Plume

a) Wake Attachment

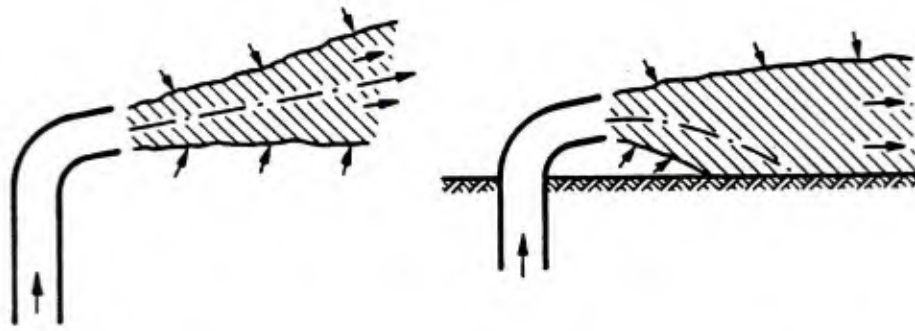

i) Free Jet

ii) Attached Jet

b) Coanda Attachment

Figure 2.9 Near-Field Attachment Processes

2.4.4.2 Coanda Attachment

When a jet discharges parallel (or near-parallel) to a boundary that is located nearby, rapid dynamic attachment can occur. This process is often referred to as a "Coanda effect". It occurs because of the entrainment demand of the jet flow at its periphery. If a boundary limits the approach flow of ambient water then low pressure effects cause the jet to be deflected towards that boundary thereby forming a wall jet. Thus the mixing process of Coanda attached flow is governed by wall jet dynamics. Criteria for the occurrence of Coanda attachment under the added influences of buoyancy or weak crossflow are discussed in the following chapter.

Chapter III

Hydrodynamic Flow Classification

The previous chapter has presented a summary of the multitude of distinct flow and mixing processes that can occur with effluent discharges into the water environment. Obviously, depending on the interplay of these mixing processes, the size and appearance of any discharge flow field and its associated mixing zone may vary greatly from case to case.

In this chapter, a rigorous flow classification scheme is developed that classifies any given discharge/environment situation into one of several flow classes with distinct hydrodynamic features. The classification scheme places major emphasis on the near-field behavior of the discharge and uses the length scale concept as a measure of the influence of each potential mixing process. Flow behavior in the far-field, mostly in the form of boundary interactions, is also discussed herein.

3.1 Ambient and Discharge Data: Geometry and Flow Variables

Given the diversity of possible ambient environments (e.g. highly varying water depth, curved channels, unsteady flow conditions, etc.) some form of engineering simplification, or schematization, is necessary to perform predictions of effluent flow conditions and mixing zone analyses.

3.1.1 Ambient Geometry and Flow Conditions

Ambient conditions are defined by the hydrographic and geometric conditions in the vicinity of the discharge. For this purpose, typical cross-sections normal to the ambient flow direction at the discharge site and further downstream need to be considered. The cross-section can be defined as: i) bounded cross-section: If the cross-section is bounded on both sides by banks - as in rivers, streams, narrow estuaries, and other narrow watercourses -, then the cross-section is considered "bounded", and ii) unbounded cross-section: In some cases the discharge is located close to one boundary while the other boundary is for practical purposes very far away. This would include discharges into

wide lakes, estuaries and coastal areas. These situations are defined as "unbounded".

The following flow classification and subsequent predictive models assume a rectangular cross-section that is given by a width and a depth which are constant in the downstream direction following the ambient flow. Thus if the actual ambient is curved or meandering, it is assumed that the schematic rectangular cross-section represents a straight "stretched-out" counterpart. The discharge and ambient schematization for a typical single-port discharge appear in Figure 3.1.

This schematization may be quite evident for well-channeled and regular rivers or artificial channels. For highly irregular cross-sections or unbounded sections, it may require more judgement and experience, perhaps combined with an iterative use of the classification scheme, to get a better feeling on the sensitivity of the results to different schematizations.

The hydrodynamic classification assumes steady state ambient flow conditions. Thus for time varying ambient flows, as in tidal currents, a quasi-steady analysis must be conducted choosing certain design flow conditions. Generally this is acceptable because the time scale for variation in ambient currents (e.g. the tidal period) is usually much larger than the time scale for near-field mixing processes (in the order of minutes to tens of minutes). Furthermore, any shear effects in the ambient flow are neglected and a uniform velocity equal to the depth-averaged value is assumed.

3.1.2 Ambient Density Stratification

Ambient density stratification occurs frequently in aqueous environments. A stable density profile occurs when density increases vertically with increasing depth from the water surface to the bottom. If the density decreases with depth, the water column is unstable, and subsequent overturn mixing will eventually yield a stable or uniform profile. In the unstable density profile, water of lesser density located below water of greater density would rise towards the surface, and water of greater density would sink towards the bottom. Density stratification may be associated with variations of salinity or temperature within the vertical water profile.

Stable density variations in ambient environments can arise in many possible profiles. Four simple representative

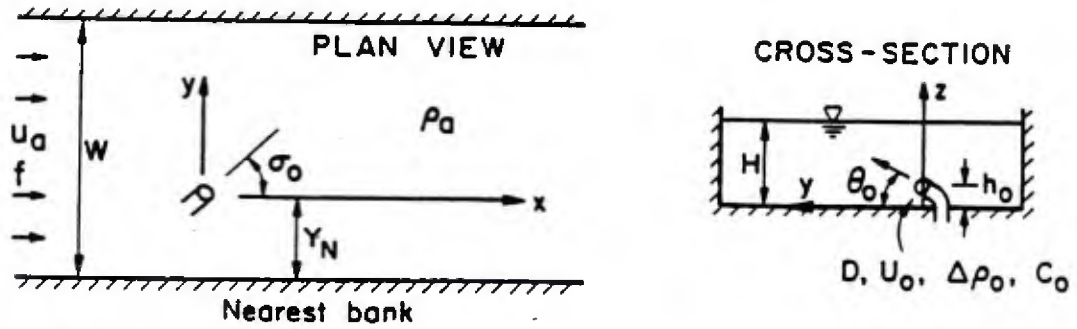

Flux quantities: $Q_0 = \text{discharge}$
 $M_0 = U_0 Q_0 = \text{momentum flux}$
 $J_0 = (\Delta\rho_0/\rho_a) g Q_0 = \text{buoyancy flux}$

Figure 3.1 Definition Diagram for Single Port Discharge Geometry in Ambient Channel with rectangular Cross-Section. Width W of the water body may be finite or unlimited.

density profiles are illustrated in Figure 3.2. Any existing ambient stratification is approximated by the schematic profile that most closely resembles it. A dynamically correct approximation of the actual distribution should keep a balance between over- and under-estimation of the actual density data.

The simplest case is a linear density profile shown in Figure 3.2a (Stratification Type A). Figure 3.2b describes two uniform density layers with a density jump between layers (Stratification Type B). This density jump is often referred to as a pycnocline or thermocline. Figure 3.2c illustrates a two layer profile in which the upper layer is uniform, the lower layer has a linear stratification, and a density jump occurs between layers (Stratification Type C). Finally, Figure 3.2d presents a two layer system with a uniform upper layer and a linearly stratified bottom layer with no density jump between layers (Stratification Type D). The uniform upper layers in Stratification Types B, C, or D is representative for the well mixed upper layer (often referred to as the epilimnion) that is found in many types of ambient water bodies and occurs due to wind induced turbulent mixing.

3.1.3 Discharge Parameters

The salient discharge conditions are shown in Figure 3.1. The discharge geometry is given by the diameter D of the port or nozzle, its height h_0 above the bottom, and its orientation angles θ_0 and σ_0 .

The vertical angle of discharge θ_0 is the angle of the port centerline measured from the horizontal plane. For practical applications, this angle may range between -45° and 90° . As examples, the vertical angle is 90° for a discharge pointing vertically upward, and it is 0° for a horizontal discharge. The horizontal angle of discharge σ_0 is the angle measured counterclockwise from the ambient current direction (x-axis) to the plan projection of the port centerline. This angle may range between 0° and 360° . As examples, the horizontal angle is 0° if the port points downstream with the ambient flow (co-flowing discharge), it is 90° or 270° if it points across the ambient flow (cross-flowing discharge), and it is 180° if it points upstream opposing the ambient flow (counter-flowing discharge).

The important dynamic variables of the discharge are its momentum flux M_0 , its buoyancy flux J_0 , and to a lesser degree, the discharge flow (volume flux) Q_0 . These bulk parameters, first derived in Chapter II, are listed on Figure 3.1. Note that in case of stratified ambients, the

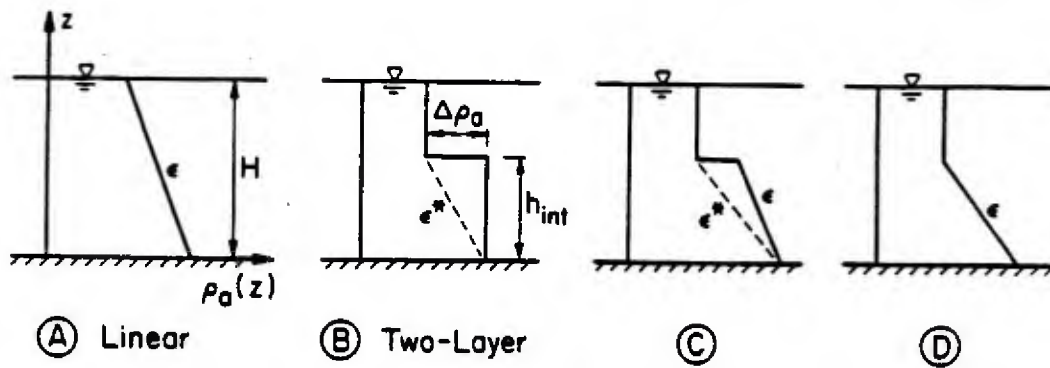

Figure 3.2 Representative Stable Density Profiles (Four Stratification Types)

discharge buoyancy g_0' refers to the ambient density conditions at the level of the discharge, h_0 , i.e. $g_0' = g(\rho_s(h_0) - \rho_0) / \rho_s(h_0)$.

3.2 Near-field Flow Classification

The purpose of the hydrodynamic flow classification is to predict for a given discharge/environment situation the type of flow configuration that will occur. Once a reliable classification has been established, it becomes much easier to provide actual predictions for flow properties including pollutant concentration distributions within the distinct hydrodynamic zones pertaining to each flow class.

The present flow classification procedure uses the length scale concept. The dynamic length scales characterizing the discharge are summarized in Table 3.1. There are six major scales: L_b , L_M , L_b' , L_M' , and L_b'' . It should be noted that there are functional interdependences, e.g. $L_M = L_M^{3/2} / L_b^{1/2}$ and $L_b' = L_M'^{3/2} / L_M^{1/2}$, and it can be readily shown that there are only four independent length scales. These length scales interact with the geometric properties of the ambient water body, its layer depth H_s , stratification ϵ , and orientation angles θ_0 and σ_0 .

Thus in total at least seven independent length parameters plus two angles seem to influence the near field flow configuration, even within the relatively simple rectangular channel schematization discussed in Section 3.1. Assuming two values (high and low) for each of these lengths, two values of 0 or 90° for θ_0 , and three values of 0° , 90° (or 270°), or 180° for σ_0 , it appears that there exist at least $2^{7-1} \times 2 \times 3 = 384$ possible different flow configurations! Indeed such a simple calculation gives an indication of the potential variety of flow patterns that can occur in environmental conditions.

In fact, many of these potential configurations are not possible on theoretical grounds, and many will not occur for practical reasons. The classification procedure presented below yields 35 generic flow configurations. The actual number of flow classes that can be modeled with the full predictive methodology (Chapter V) is considerably larger (about 100 flow classes) since: i) each of the 35 generic flow classes may apply to a layer corresponding to the full water depth or to the region below a pycnocline, and ii) certain sub-processes may be present or absent in a particular flow classes (a typical example is the absence of a weakly deflected jet region close to the discharge port if the ambient velocity is very large).

Table 3.1 Flow Classification Variables and Length Scales

Ambient and Discharge Variables:

H = ambient depth at discharge

h_0 = discharge port height above bottom

h_{int} = ambient internal density jump height

H_s = stratified layer height (equal to H or h_{int})

u_a = ambient velocity

f = Darcy-Weisbach friction factor for ambient shear flow

θ_0 = discharge vertical angle

σ_0 = discharge horizontal angle relative to current

Length Scales:

$L_0 = Q_0/M_0^{1/2}$ = discharge (geometric) scale (Eq.2.9)

$L_M = M_0^{3/4}/J_0^{1/2}$ = jet/plume transition scale (Eq.2.12)

$L_m = M_0^{1/2}/u_a$ = jet/crossflow scale (Eq.2.10)

$L_b = J_0/u_a^3$ = plume/crossflow scale (Eq.2.11)

$L_m' = (M_0/\epsilon)^{1/4}$ = jet/stratification scale (Eq.2.13)

$L_b' = J_0^{1/4}/\epsilon^{3/8}$ = plume/stratification scale (Eq.2.14)

3.2.1 General Procedure

The flow classification is a 13 step procedure that is summarized in Table 3.2. This procedure is used to determine which of four major flow categories the given discharge will exhibit. The four major flow categories are: i) flows affected by linear stratification leading to internal trapping (S classes, Figure 3.3), ii) buoyant flows in a uniform ambient layer (V and H classes, Figure 3.4), iii) negatively buoyant flows in a uniform ambient layer (NV and NH classes, Figure 3.5), and iv) bottom attached flows (A classes, Figure 3.6).

Even though a stable ambient density profile may be specified for a given situation, that profile may be weak or even dynamically impossible in the presence of the destabilizing effect of an ambient flow with mean velocity u_a . In Step 1 of Table 3.2 a flux Richardson criterion (see Appendix A) is used to check for such destabilization which would enforce a uniform profile.

Steps 2 through 8 in Table 3.2 determine the effect of ambient density stratification (if present) on the flow. In general, if the predicted terminal height of rise Z_t for near-field flows is greater than the actual layer height H_s , then the effect of the linear stratification will be unimportant and the buoyant jet will traverse this layer as if it were in fact of uniform density.

If the terminal height of rise Z_t is less than the layer height H_s , additional tests (Steps 3 through 7, Table 3.2) are performed. In the case of a profile with a density jump (Stratification Types B and C in Figure 3.2) these tests determine if the flow will be trapped by the pycnocline, or in the case of Stratification Type C, trapped within the lower density layer. If the flow is trapped by the pycnocline, the details of stratification below the pycnocline are unimportant and the region below the pycnocline will be represented by a uniform density layer in all cases.

Step 9 is the detailed flow classification for those flow classes whose dynamics are directly affected by linear ambient stratification. The linearly stratified layer may extend over the full water depth or be confined to the region below the pycnocline. Further details on this classification are given in Section 3.2.2.

Steps 10 to 12 examine the flow behavior for those categories in which the ambient layer can be taken as uniform (either existing or because any stratification is

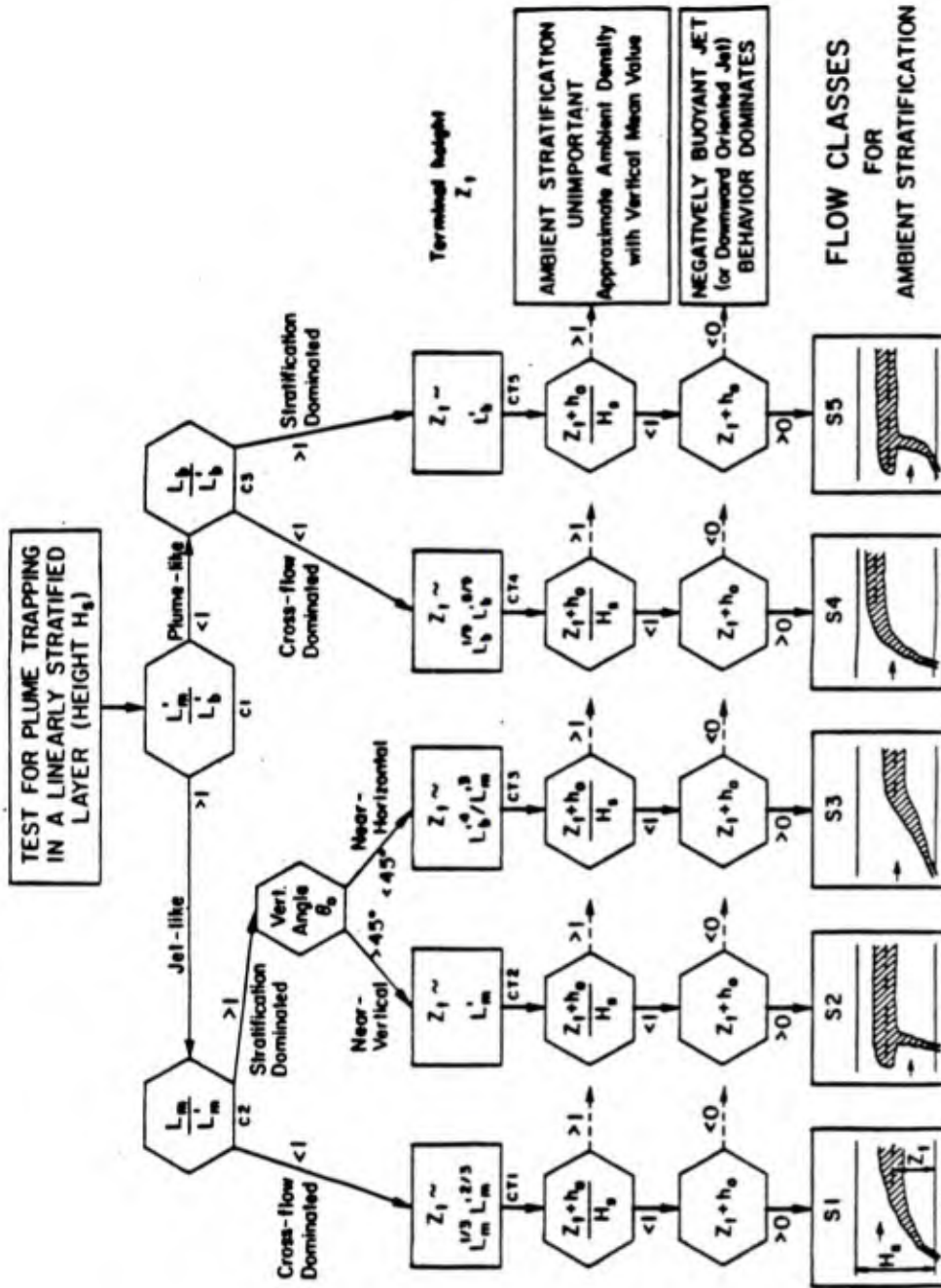

Figure 3.3 Sub-Classification: Assessment of Ambient Density Stratification and Different Flow Classes for Internally Trapped Discharges.

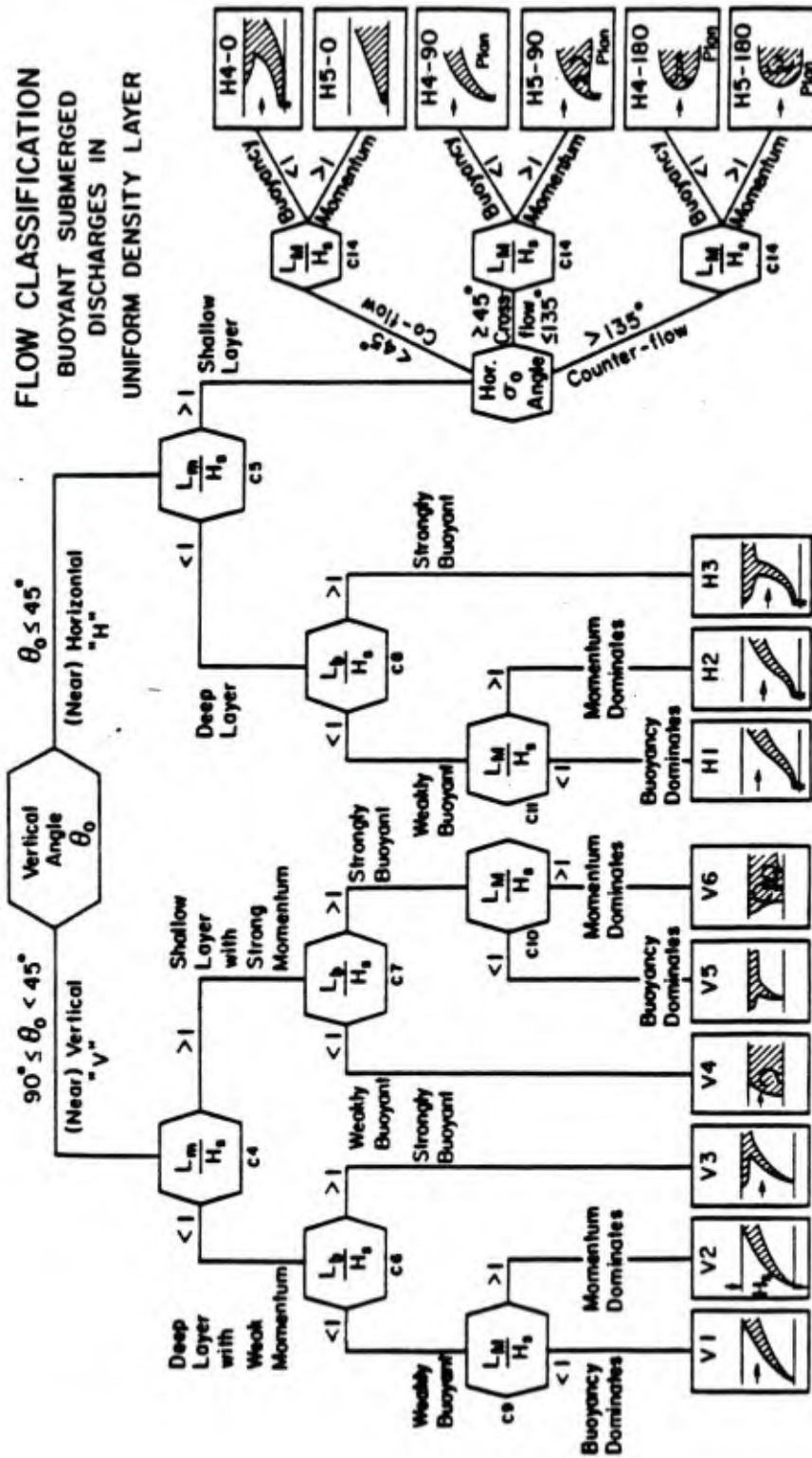

Figure 3.4 Sub-Classification: Behavior of Positively Buoyant Discharges in Uniform Ambient Layer.

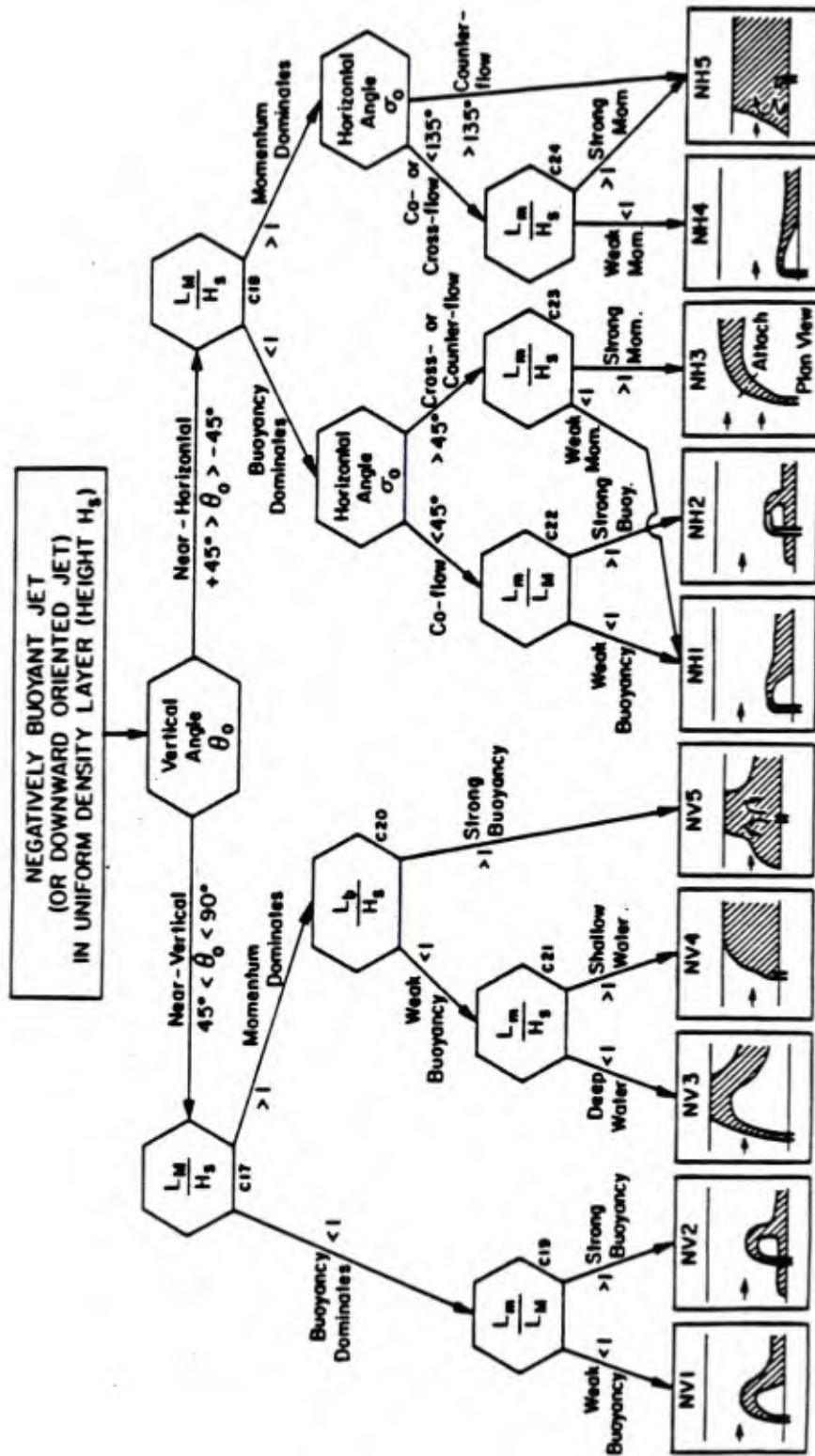

Figure 3.5 Sub-Classification: Behavior of Negatively Buoyant Discharges in Uniform Ambient Layer.

CLASSIFICATION BOTTOM ATTACHMENT

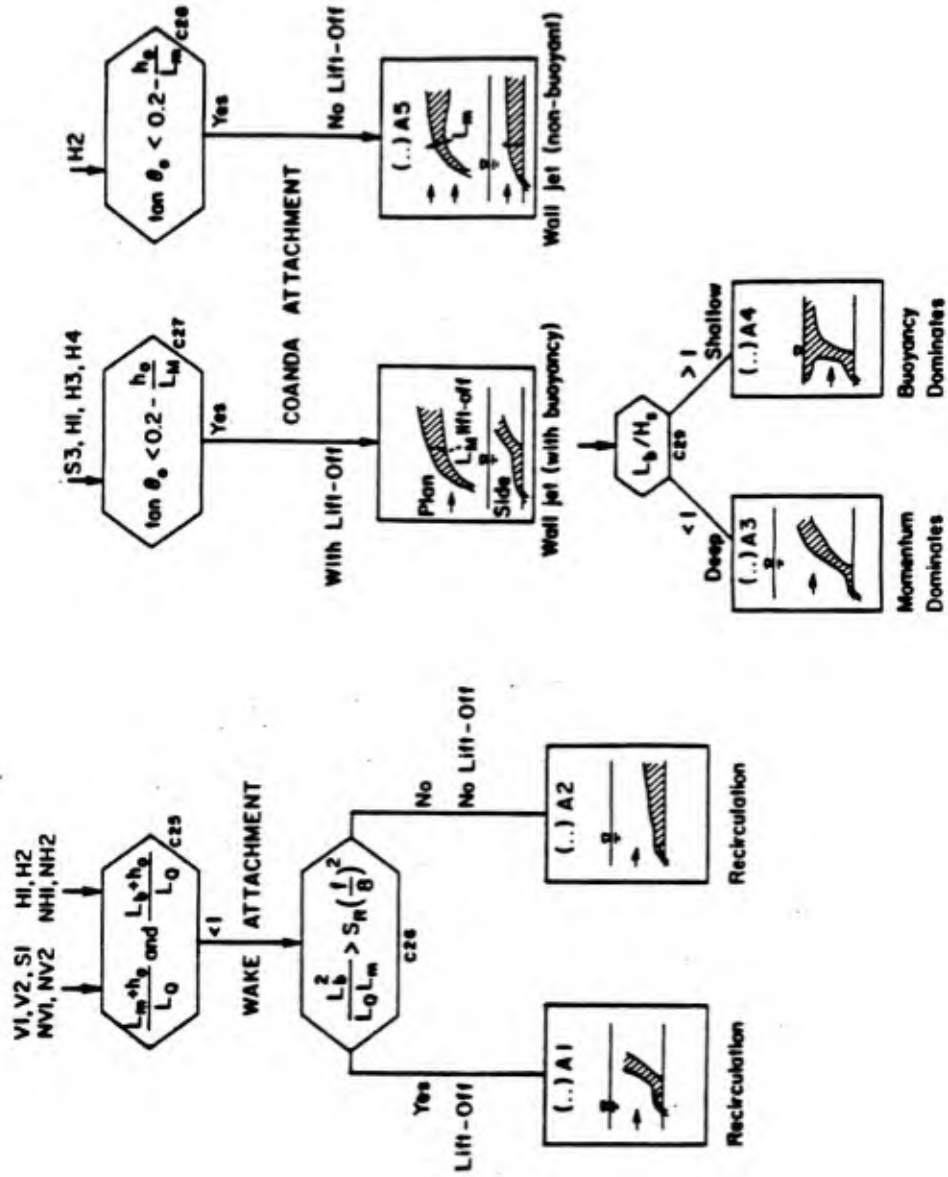

Figure 3.6 Sub-Classification: Dynamic Bottom Attachment of Discharge Due to Wake or Coanda Effects.

Table 3.2 Near-Field Flow Classification Procedure

- Step 1: Test for density profile stability. If the ambient is unstratified or the given stratification is dynamically impossible according to a flux Richardson number criterion, approximate ambient density with mean value and recompute discharge parameters. Conclude stratification is not important and go to Step 10.
- Step 2: Ambient has stable density stratification. Check for density step change. If the ambient does not contain a density step change (Types A or D in Figure 3.2) go to Step 4.
- Step 3: Ambient density profile contains step change. Since the Stratification Type is B or C, approximate the actual lower layer stratification and the step change with a surrogate linear stratification (Figure 3.2). Calculate surrogate gradient ϵ^* and surrogate stratification length scales L_m' and L_b' .
- Step 4: Possible flow trapping in linear density stratification. Test for internal layer formation (flow trapping), using the scheme outlined in the upper portion of Figure 3.3. Use height H_s ($H_s = H$ for Stratification Type A, and $H_s = h_{int}$ for Types B, C or D). If $(Z_t+h_0)/H_s > O(1)$, density stratification will not trap flow. Therefore conclude ambient density stratification is not dynamically important. Approximate ambient density with mean value, recompute discharge parameters, and go to step 10.
- Step 5: Stratification is important and flow trapping may occur. If there is no density jump in the profile (Types A or D) go to Step 8.
- Step 6: Test for trapping at density jump or in linearly stratified layer. If Stratification Type is C, perform a second test for internal layer formation using the scheme outlined in the upper portion of Figure 3.3 based on the actual density gradient ϵ . If $(Z_t+h_0)/H_s < O(1)$, conclude the flow will become trapped in the linearly stratified layer below the density jump, go to Step 8.

Table 3.2 (continued)

- Step 7: Trapping at the density jump (pycnocline). The linear stratification below the density jump is dynamically unimportant. The effluent flow will be confined to the lower layer of Stratification Types B or C due to the strong density jump. For Type C, approximate linear ambient density profile of lower layer with mean, and recompute discharge parameters. Set $H_s = h_{int}$ and go to Step 10.
- Step 8: Check for flow interaction with bottom for flows influenced by linear density stratification. Flow may interact with bottom if its buoyancy is negative or jet is directed downward. If $Z_t + h_0 < 0$, flow will interact with the bottom. Proceed to Step 12.
- Step 9: Complete flow classification for buoyant jet in linearly stratified layer. Five flow classes exist (S1 to S5) as shown in Figure 3.3. Go to Step 13 for final check on near-field bottom attachment.
- Step 10: Test for discharge buoyancy in uniform ambient density layer height H_s . If discharge is negatively buoyant go to Step 12.
- Step 11: Perform flow classification for positively buoyant (or neutral) jet in uniform density layer. Fifteen major flow classes (V1 to V6, H1 to H5) exist as shown in Figure 3.4. Go to Step 13 for final check on near-field bottom attachment.
- Step 12: Perform flow classification for negatively buoyant or downward directed jet in uniform density layer. Ten major flow classes exist (NV1 to NV5, NH1 to NH5) as shown in Figure 3.5. STOP.
- Step 13: Perform flow classification for bottom attached effluent flows. Five major attached flow classes exist (A1 to A5) in the form of wake and Coanda effects as shown in Figure 3.6. STOP.

weak and dynamically unimportant compared to the discharge fluxes). The detailed classification for positively buoyant (or neutral) discharges in such a layer is contained in Step 11 (see Section 3.2.3) and for negatively buoyant discharges is given in Step 12 (see Section 3.2.4).

The final Step 13 performs an additional test and classification for dynamic bottom attachment (see Section 3.2.5). Most (but not all) of the flow classes that may have been concluded in Step 8, 11, or 12 may experience such attachment effects which then radically alter the near-field flow configuration leading to a new category of attached flows.

The detailed classification schemes for each flow category (Figures 3.3 to 3.6) are discussed in the following sections. It is stressed that all criteria presented in this chapter and listed on Figure 3.3 to 3.6 are "order of magnitude" relations. The precise form of the criteria as well as the numerical constants are given in Chapter V.

3.2.2 Flow Classes 8 for Linear Ambient Stratification

Referring to Figure 3.3, the first test level of the flow classification for a buoyant jet in a linearly stratified layer is to determine whether the flow is mostly jet-like or mostly plume-like as it rises in the stratified layer. This is achieved through the comparison of the stratification length scales, L_m'/L_b' .

The next determination is the relative importance of crossflow on these stratified flows. For jet-like stratified flows, if $L_m/L_m' < O(1)$, the crossflow will have strongly deflected the buoyant jet flow by the time the stratification starts to influence the flow leading to a "crossflow dominated" regime. But for $L_m/L_m' > O(1)$ the crossflow is weak and the flow is "stratification dominated."

For plume-like stratified flows, if $L_p/L_b' < O(1)$ the crossflow will have strongly deflected the buoyant plume flow before the stratification begins to affect the flow leading to a "crossflow dominated" regime. On the other hand, $L_p/L_b' > O(1)$ signifies a "stratification dominated" flow.

The terminal height of rise Z_t predicted for any of these flows is indicated on Figure 3.3. Detailed discussion and references for these equations are in Section 5.3. In general, the height of rise depends on L_m' or L_b' with an added influence of L_m or L_p for crossflow affected stratified flow. The sketches at the bottom of Figure 3.3 indicate the

schematic flow configuration for each flow class. Once the terminal height has been reached, some flows (S1 or S4) are further deflected by the strong crossflow leading to far field buoyant spreading and diffusion phases. Other flows (S2 or S5) have weak crossflow and are more nearly vertical in approach ("impingement") to the terminal layer with an ensuing upstream spreading phase. Flow class S3 with strong horizontal momentum experiences a (near-)horizontal "injection" into the terminal layer.

3.2.3 Flow Classes V or H for Buoyant Discharges into Uniform Ambient Layers

The flow classification system for positively buoyant discharges in uniform ambient layers appears in Figure 3.4. Two major branches occur within this classification depending on the vertical angle of the discharge θ_0 , as shown in Figure 3.4. The vertical discharge angle θ_0 is used to define the sub groups of (near-)vertical (V classes) and (near-)horizontal discharges (H classes). This distinction is necessary because V classes may have surface contact with strong vertical momentum, while for the H classes the momentum is directed in the horizontal plane.

The flow classification system then uses the ratio of L_w/H_s to characterize the discharge as "deep water" or "shallow water" based on the momentum of the flow as it contacts the surface. A deep water discharge will have relatively weak momentum as the flow contacts the surface, while a shallow discharge will have strong momentum as the flow is influenced by, or impinges on, the surface.

The next level of the classification assesses the role of buoyancy with respect to the ambient layer height H_s . For $L_w/H_s > 0(1)$ the flow will have a strong buoyancy effect when contact with the surface or upper layer occurs, while for $L_w/H_s < 0(1)$ the buoyancy influence will be minor.

An additional determination needs to be made in those cases where both momentum and buoyancy effects have found to be weak, or both to be strong, respectively. A criterion L_w/H_s is used to determine which one of the two effects predominates.

As a result, discharges can be classified as "stable" or "unstable". Flows with strong momentum and weak buoyancy occurring in shallow water layer tend to be unstable (V4, V6, and H5). In this case the jet is affected by the shallowness and an unstable recirculation zone occurs around the jet as it re-entrains the fluid already mixed. In a stable discharge, buoyancy tends to have a stabilizing

effect on the flow as it contacts the surface, causing the flow to form a stratified layer on the surface.

Discharges into deep water layer have stable flow classes (V1, V2, V3, H1, H2, and H3), with strong similarity among the V and H classes in this case, as well as the shallow water cases V5 and H4 that have extremely strong buoyancy as a stabilizing factor in an otherwise shallow layer. Some of these stable flow classes with strong buoyancy (V3, V5, H3, and H4) experience upstream spreading once surface contact has occurred.

An important aspect of such a classification scheme is its robustness under extreme conditions. Two such conditions are of interest; i) zero discharge buoyancy ($g_0' = 0$ and thus $J_0 = 0$), and ii) stagnant ambient ($u_a = 0$). In the first case, the length scales are $L_b = 0$, and L_m goes to infinity. In the second case L_m goes to infinity. In the combined case (zero buoyancy flux and ambient velocity) L_b is indeterminate.

Case i) Non-buoyant discharges into a flowing ambient lead to flow classes V2 or H2. A special sub class of this flow is a rapidly deflected small "passive source" (well below the layer surface) with a rapid transition to far-field ambient diffusion.

Case ii) Stagnant ambient conditions lead to flow classes V5, V6, H4, or H5, respectively. In particular, if the discharge is weakly buoyant (or, in the extreme, nonbuoyant) flow classes V6 or H5 will occur. Obviously, far-field mixing process are absent for these situations, which rarely occur anyway in actual environmental conditions.

The flow classes H4 and H5 contain a sub-classification depending on whether the discharge is coflowing ($\sigma_0 \approx 0^\circ$), cross-flowing ($\sigma_0 \approx 90^\circ$), or counter-flowing ($\sigma_0 \approx 180^\circ$). This is necessary since the strong horizontally oriented momentum flux in these shallow environments leads to a drastically different flow configuration as a function of discharge direction relative to the crossflow. In fact some of these configurations (e.g. the counter-flowing ones) lead to complicated recirculation zones that may be difficult to analyze and undesirable in actual design practice.

3.2.4 Flow Classes NV or NH for Negatively Buoyant Discharges in Uniform Ambient Layers

The classification system for negatively buoyant discharges (Figure 3.5) bears some similarities to that for positively buoyant discharges described above. Several

negatively buoyant flow classes have a "mirror image" analogy to positively buoyant flows which appear in Figure 3.4.

Again, the flow classification system has two main branches; for discharge angles $\theta_0 \geq 45^\circ$ the flows are classified as near-vertical (NV-classes), while for $-45^\circ < \theta_0 < 45^\circ$ the flows are classified as near-horizontal (NH-classes).

The first level is to determine if momentum or buoyancy dominates with respect to the ambient layer depth H_s . If $L_w/H_s < O(1)$ the flow will be buoyancy dominated after a short distance and therefore will not have any surface interaction. If it is discharged upward, it will quickly fall back towards the bottom. If $L_w/H_s > O(1)$ the flow will be momentum dominated in relation to the ambient layer depth H_s . For near-vertical jets, surface interaction will occur. For near-horizontal discharges, the potential for surface interaction will depend on the horizontal angle of discharge σ_0 .

Additional tests for flow behavior are based on the crossflow scales L_m and L_b . The negatively buoyant flow classes are separated into those without layer or surface interaction (NV1, NV2, NH1, NH2, NH3, and NH4) and those with interaction (NV3, NV4, and NV5). The extremely strong negative buoyancy causes upstream spreading in flow classes NV2 or NH2. Unstable discharge configurations with vertical mixing and recirculation zones exist in flow classes NV4, NV5, and NH5. Finally, it should be noted that this classification also applies for a downward oriented jet ($\theta_0 < 0^\circ$, regardless of buoyancy) that is trapped by linear ambient stratification near the bottom of the water layer (see Step 8 of Table 3.2). In this instance, flow configurations NH1 to NH3 may result.

3.2.5 Flow Classes (...)A for Bottom Attached Flows

Two types of flow attachment appear in Figure 3.6: wake attachment and Coanda attachment. The physical processes for these have been described in the previous chapter. Several flow classes appear to be prone to some kind of

¹Strictly speaking L_m and L_b are negative quantities for negatively buoyant discharges since $g_0' < 0$, and thus $J_0 < 0$. In this classification the absolute values of these quantities are used.

attachment while others are not as shown in Figure 3.6. For example, a vertical discharge cannot experience Coanda attachment.

Wake attachment will not occur if the effluent intrudes sufficiently far away from the boundary. An estimate of the intrusion distance is given by the sum of port height h_0 and the crossflow length scale L_m for jet-like or L_p for plume-like flows, respectively. If these intrusion distances are small relative to the source dimension, $(L_m + h_0) < L_p$, and $(L_p + h_0) < L_m$, then wake attachment to the bottom will occur. A supplementary criterion based on a local Richardson number condition tests for potential buoyant lift-off (flow class A1) following the recirculation zone in the wake of the discharge (see Figure 3.6). For weak (or negative) buoyancy no such lift-off will occur (flow class A2).

Jet-induced Coanda attachment depends primarily on the vertical angle θ_0 of the (near-)horizontal discharge and on the initial jet separation given by the total spreading angle (with a tangent of 0.2 for a jet flow). A simple criterion for attachment is indicated by $\tan\theta_0 < (0.2 - h_0/L)$ where L is the distance of the jet region. For weak crossflow (stagnant) conditions, L is given by the jet/plume scale L_m leading to flow classes A3 or A4, depending on the strength of buoyancy. In a strong crossflow, L is given by the jet/crossflow length scale L_m , leading to flow class A5.

As has been noted earlier, the flow class is checked for wake and Coanda attachment after the primary classification (S, V, NV, or NH) has been completed. In the actual expert system implementation of this scheme, if the flow is attached, it is given the appropriate attachment suffix (e.g. A2) to the already determined flow class (e.g. V1A2). This is done for practical reasons as a guidance to the analyst: simple modification of the discharge geometry (e.g. a larger angle θ_0) can often lead to avoidance of attachment in which case the primary flow class (e.g. V1) will describe the flow.

3.3 Far-Field Flow Behavior

After the effluent flow has interacted with the water surface, bottom, pycnocline, or terminal layer and has thus completed its near-field phase, the far field mixing begins. This region consists of one or two mixing processes, depending on discharge characteristics. In the general case, the discharge flow contains sufficient buoyancy and there will be a buoyant spreading region followed by a passive diffusion region. The buoyant spreading region is

characterized by dynamic horizontal spreading and gradual vertical thinning of the mixed effluent flow while being advected by the ambient current. Vertical boundary interaction may occur, and the flow may contact one or both lateral boundaries (shorelines). In the passive diffusion region, the dilution is controlled by the turbulent mixing action of the flowing ambient water body. Again, boundary interaction may occur, and the flow may become both laterally and vertically fully mixed within the layer height H_p in this region. If the flow is non-buoyant or weakly buoyant there is no buoyant surface spreading region, only a passive diffusion region.

In contrast to the near-field flow there is no need for an advance classification scheme to determine the behavior of the far-field flow for a given discharge/environment situation. Since the effluent flow in the far-field is always advected in the direction of the ambient flow, the various interaction processes are simply calculated as part of the downstream modeling process of the applicable far-field solutions. This applies also to the transition between buoyant spreading and passive ambient diffusion (based on a flux Richardson number criterion). These aspects are directly implemented in the predictive elements for the detailed effluent flow and mixing zone predictions as summarized in Chapter V.

Chapter IV

Expert System CORMIX1: General Framework

The Cornell Mixing Zone Expert System, Subsystem 1 (CORMIX1) contains a series of software elements for the analysis and design of conventional or toxic single port submerged buoyant or nonbuoyant pollutant discharges into stratified or unstratified watercourses, with emphasis on the geometry and dilution characteristics of the initial mixing zone. It is intended as an analysis tool for environmental regulators, discharge designers, and more generally, students of hydraulics. The system is designed for use under the MS-DOS operating system on an IBM-PC/XT with a hard disk and a math co-processor as the minimum hardware configuration.

The user supplies CORMIX1 with information about the discharge and ambient environment. CORMIX1 returns information detailing the hydrodynamic mechanisms controlling the flow, dilution, geometric information concerning the shape of the pollutant plume or flow in the ambient water body, and design recommendations allowing the user to improve the dilution characteristics of the flow. If specified by the user, CORMIX1 also presents information about the legal mixing zone dimensions and dilution, toxic mixing zone requirements, and zone of interest characteristics for the flow.

The purpose of CORMIX1 is to obviate for the novice analyst the need for detailed understanding and experience in hydrodynamic mixing processes. A general environmental science or engineering background at the BS level appears to be the minimum educational requirement needed to compile and supply relevant data, interpret the system information, and ultimately learn and become knowledgeable about hydrodynamic mixing through repeated interactive use. Two working days appear to be required for a first time user to gain initial facility with system requirements, limitations, and interpretation of results.

Depending on the computer configuration, a typical CORMIX1 session for one discharge/environment condition may take about 5 minutes for an advanced 80386-based micro-computer to 20 minutes for an IBM-PC/XT, if all necessary input data is at hand.

4.1 Background on Expert Systems and Logic Programming

CORMIX1 is implemented in two programming languages: VP-Expert (Paperback Software, Inc.), and Fortran. VP-Expert is an expert systems programming language, or more precisely, a "shell". A shell is a self-contained inference engine that does not contain the knowledge base, but has facilities for both forward and backward reasoning, debugging aids, consistency checking, input and output menus, and explanation facilities. The two programming languages are used to exploit their respective strengths while avoiding their respective weaknesses. VP-Expert, as a knowledge base language, is very efficient in knowledge representation and symbolic reasoning; however it is relatively weak in numerical computational ability. On the other hand, Fortran is ideal for computation of mathematical functions (Fortran stands for formula translator) but is poorly suited for the tasks associated with symbolic reasoning. Thus VP-Expert is employed to implement the knowledge acquisition, simple length scale and dynamic variable calculation, model selection, and analysis of the hydrodynamic simulation portions of the expert system. Fortran is used for the hydrodynamic flow simulation, which is called from a VP-Expert program element.

It is interesting to note that the entire system could have been programmed in a language such as Fortran, or even assembly language; the real issue is one of programming efficiency. For instance, a routine written in 5 lines of Fortran code might take 100 lines of assembly level source code. Since VP-Expert was developed to encode and manipulate symbolic logic, it does so with great efficiency, allowing the programmer to write in 5 lines of code what might take 100 lines in Fortran or 1000 lines of assembly language. In essence the selection of VP-Expert as the language for the symbolic reasoning tasks gives the programmer significant leverage. A VP-Expert knowledge base is very similar in structure to a PROLOG (PROgramming LOGic) program. PROLOG was developed in Europe and is designed to manipulate logical expressions (Clocksin and Mellish, 1984). A VP-Expert program is built from statements containing facts and if-then rules about facts. This is called the knowledge base. The knowledge base is constructed with an expert in the problem domain, in this case hydrodynamic mixing processes.

Logic programs, such as VP-Expert, are driven by a "goal" which the program tries to validate by searching the knowledge base to construct a "proof". The proof is constructed by using the facts and rules in the knowledge base to deduce the goal as a valid hypothesis. The following paragraphs give a more detailed explanation of how this is accomplished, using the CORMIX1 knowledge base

AMBIENT as an illustrative example. AMBIENT is a knowledge base designed to gather information on ambient conditions at the discharge site.

The execution of each knowledge base program is driven by attempting to satisfy a goal. In the AMBIENT knowledge base this is written in VP-Expert as:

```
FIND = ambient_conditions [1]
```

Here the goal is to satisfy or find a valuation for the expression "ambient_conditions".

All rules in VP-Expert are stated as: if {expression(s) or clauses called the "premise" or "head" of the rule} - then {an expression or clause called the "conclusion" or "tail" of the rule} statements. The premise of a rule in VP-Expert can contain more than one expression connected by and/or statements. VP-Expert will try to satisfy the goal (here the expression "ambient_conditions") by searching for a rule in the knowledge base whose conclusion contains the expression "ambient_conditions = (valuation)".

A rule in AMBIENT that has "ambient_conditions = known" in its conclusion is:

```
if ambient_advice <> UNKNOWN and
   bounded_section = yes and
   channel_width <> UNKNOWN and
   depths <> UNKNOWN and
   nearest_bank <> UNKNOWN and
   ambient_velocity_field <> UNKNOWN and
   friction_factor <> UNKNOWN and
   ambient_density_field <> UNKNOWN
then ambient_conditions = known [2]
```

Here, in the conclusion of the rule the expression "ambient_conditions" is assigned the valuation "known".

First, an explanation is given on how VP-Expert uses information contained within if - then rules to assign valuations to expressions. VP-Expert always tries to satisfy a valuation in the conclusion of the rule by proving its premise. Thus, VP-Expert tries to satisfy all expressions in the premise of the rule, beginning in statement [2] with the first expression "ambient_advice <> UNKNOWN" (the "<>" in [2] stands for "not equal to"). If the valuation of the variable in the first clause is satisfied, i.e. the expression site_description does indeed have a valuation other than "UNKNOWN", then VP-Expert tries to satisfy the second expression, "bounded_section = yes". If this valuation is satisfied, VP-Expert will try to satisfy the remaining expressions in the premise of the

rule. Whenever in the premise the valuations for all expressions are satisfied, the rule succeeds or "fires". When the rule fires, the expression in the conclusion of the rule can be given a valuation and this information is added to the facts known in the knowledge base.

So how does VP-Expert know the expression "ambient_advice" has a valuation other than "UNKNOWN"? Because there is another rule in the knowledge base which is:

```
if ambient_query = yes
then ambient_advice = yes [3]
```

This statement is invoked by statement [2] when it tries to find a valuation for the first expression "ambient_advice". Since there is no present valuation for the expression "ambient_advice", VP-Expert locates statement [3] with the expression "ambient_advice" in its conclusion. If the expression "ambient_query" in the premise of statement [3] can be assigned a valuation equal to "yes", then the expression ambient_advice is assigned the valuation "yes" (which is not equal to "UNKNOWN"). VP-Expert will now try to find a valuation for ambient_query, the first and only expression in the premise of statement [3]. Within AMBIENT there is another rule:

```
ASK ambient_query: "Do you want a detailed
description of the ambient environmental data needed?" [4]
```

This rule is treated as a "fact", and VP-Expert prompts the user for a valuation of "ambient_query" with the message within the quotes of statement [4]. The user enters a value (yes or no) which is bound to "ambient_query". VP-Expert continues to find valuations for the remainder of the expressions in statement [2] in a similar manner. When all expressions in the premise of statement [2] are assigned a valuation, the conclusion "ambient_conditions = found" is added as a fact to the knowledge base.

Thus, as was shown with the previous example, the knowledge base AMBIENT is built from rules which contain expressions that force VP-Expert to seek valuations from other rules. The process of seeking valuations of expressions continues until either all the valuations are found or the rule base is exhausted without finding a valuation. VP-Expert will never assign a valuation which is in contradiction within a rule, so one is assured whatever valuations are concluded are taken from a rule within the knowledge base. Care must be taken in program structure however, since the search strategy of VP-Expert may not consider all rules needed to find a valuation for a given expression. In general, the rule base should be

programmed in a "tree" structure, with the most general and independent rules at the beginning of the program, and rules which depend on valuations from other rules following in the program. The most dependent and nested rules should occur last in the knowledge base.

When a valuation for a clause in the premise of a rule is found not to agree with the valuation given for that clause within the rule, e.g. the expression "depths" in statement [2] is found to have the valuation "UNKNOWN", then the rule fails, no valuation can be assigned to the expression "ambient_conditions" from that rule. VP-Expert will stop trying to satisfy the remaining expressions in the premise of that rule. VP-Expert will continue to try to satisfy the expression "ambient_conditions" by looking for another rule in the knowledge base with "ambient_conditions" in the conclusion of the rule.

Rules in AMBIENT contain additional clauses that control the manner in which intermediate conclusions are stored in memory, messages are displayed on the monitor, and other statements which create and manipulate external files for use in other CORMIX1 modules.

4.2 Structure of CORMIX1

Figure 4.1 shows the overall structure of the system elements of CORMIX1. The program elements of CORMIX1 are DATIN, PARAM, CLASS, HYDRO, and SUM. During system use the elements are loaded automatically and sequentially by the system. Table 4.1 outlines the directory structure of CORMIX1 and contains comments about program files.

The system runs entirely under the VP-Expert program shell. The hydrodynamic simulation Fortran program HYDRO is executed from the knowledge base program HYDRO. All program elements execute sequentially. For example, when a rule in a program element DATIN corresponding to statement [2] fires, the "cache" of DATIN is written to an external DOS file. The cache is a list of all expressions within a program element that have been assigned a valuation. This cache file is read by the next sequential element in DATIN, the knowledge base PARAM, and so on for the remaining program elements.

4.2.1 Data Input Element: DATIN

DATIN is a VP-Expert program for the entry of relevant data and for the initialization of the other program elements. DATIN consists of four program segments or

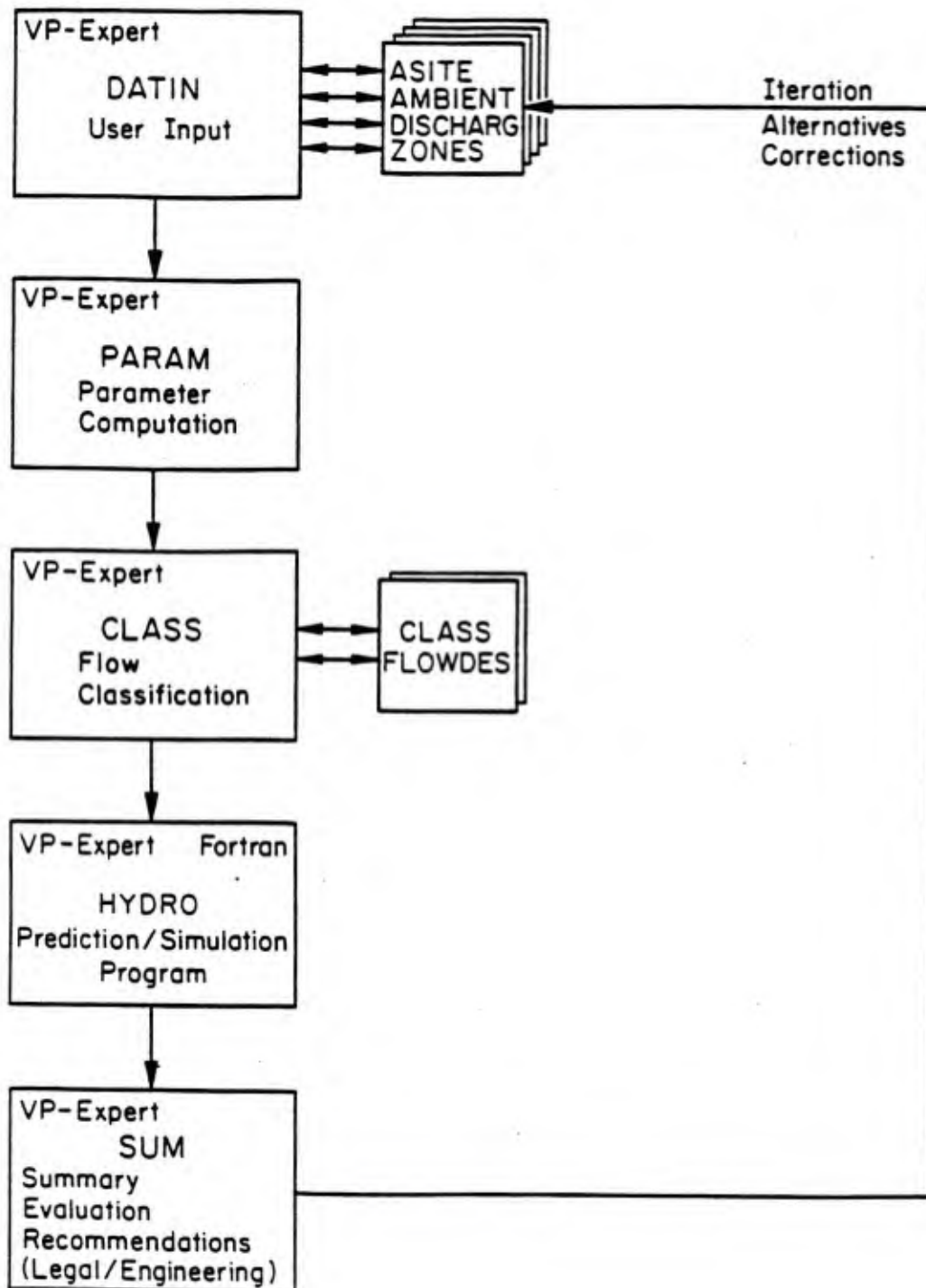

Figure 4.1 System Elements of CORMIX1

Table 4.1 CORMIX1 Program File Directories

Directory	Comments
C:\cmx	system root directory, contains VP-Expert system files and the knowledge base program CORMIX1 (system driver)
c:\cmx\advice	contains all user-requested advice files
c:\cmx\bat	contains batch files for program execution, data file manipulation, and program control
c:\cmx\cache	contains cache "fact" files exported from knowledge base programs
c:\cmx\data	contains constants used in flow classification and other knowledge base programs
c:\cmx\desc	contains flow descriptions for each flow class
c:\cmx\kbs	contains all knowledge base programs
c:\cmx\pgms	contains Fortran hydrodynamic simulation and file manipulation programs
c:\cmx\sim	contains simulation results

knowledge base sub-elements which execute sequentially. The knowledge base sub-elements are, in execution order, ASITE, AMBIENT, DISCHARG, and ZONES. The user executes DATIN by invoking the CORMIX1 expert system by entering the command "CORMIX1" at the DOS prompt. DATIN program elements automatically prompt the user for needed information.

The purpose of DATIN is to specify completely the physical environment of the discharge, as well as legal or regulatory requirements on the discharge. The following data groups need to be entered: general site and case identifier information (knowledge base ASITE), ambient conditions (geometry and hydrography, knowledge base AMBIENT), discharge conditions (geometry and discharge fluxes, knowledge base DISCHARG), and information desired including legal mixing zone definitions and toxic dilution zone criteria (knowledge base ZONES). DATIN provides consistency checks and gives advice for input parameter selection.

CORMIX1 assumes a deeply submerged single port discharge into the water body. The system assumes a schematic rectangular cross-section bounded by two banks - or by one bank only for coastal or other laterally unlimited situations. The user receives detailed instructions on how to approximate actual cross-sections that may be quite irregular to fit the rectangular schematization. The representative schematization with all relevant hydrodynamic variables that DATIN gathers, was given in Figure 3.1.

DATIN contains advice on how to enter data values and rejects inappropriate or incorrect values. A listing of the input advice available on-line to the user of CORMIX1 is given in Appendix B. DATIN will also flag unusual design cases. For example, in the knowledge base sub-element DISCHARG, if the user specifies a discharge horizontal angle which directs the effluent towards the nearest bank, the following message is displayed:

"The discharge port or nozzle points towards the nearest bank. Since this is an unusual design, make sure you have specified the discharge horizontal angle correctly. CORMIX1 will continue with the analysis with the horizontal angle as specified, but be aware that CORMIX1 may predict a hydrodynamically unstable discharge because of the interaction of the discharge near field with the bank."

At its termination DATIN triggers the next program element PARAM.

4.2.2 Parameter Computation Element: PARAM

PARAM is a VP-Expert knowledge base that computes relevant physical parameters for the given discharge situation. This includes various fluxes; Q_0 , M_0 , and J_0 , length scales L_0 , L_w , L_m , L_b , L_m' , L_b' , as well as other values needed by the remaining CORMIX1 elements. As PARAM executes, the user is notified about important characteristics of the flow. For example:

"The effluent density (1003.2 kg/m**3) is greater than the surrounding ambient water density at the discharge level (997.3 kg/m**3). Therefore, the effluent is negatively buoyant and will tend to sink towards the bottom."

At its termination PARAM triggers the next program element, the knowledge base CLASS.

4.2.3 Flow Classification Element: CLASS

CLASS is an VP-Expert program that classifies the given discharge into one of the many possible flow configurations that have been presented in Chapter III (Figures 3.3 to 3.6). CLASS contains two program elements, the knowledge base sub-elements CLASS and FLOWDES.

The goal of CLASS is to find a valuation for the expression "flow_class" in relation to the flow classification scheme. Each of the possible flow classifications has an alphanumeric label(e.g. V1, S1, H1A1, etc.). CLASS inputs a cache created by PARAM that contains the length scales and other dynamic variables needed for flow classification, and uses the knowledge base rules to assign the appropriate classification to the flow. CLASS first tries to satisfy the goal of "flow_class" by initially seeking a value for "flow_type". For example a rule corresponding to flow case V2 would appear in simplified form for illustration purposes as:

```
if flow_type = UNKNOWN and
uniform_layer_flow = yes and
flow_direction = upward and
THETA > 45.0 and
THETA <= 90.0 and
C4 > (Lm / (0.8*(HS-H0))) and
C6 > (Lb / (0.8*(HS-H0))) and
C9 <= (LMM / (0.8*(HS-H0)))
then flow_type = V2
      coanda_attachment = no
find wake_attachment
```

[5]

in which C4, C6, and C9 are constants. If all of the conditions in the premise of [5] are true, then "flow_type" is assigned a value of V2. The possibility of Coanda attachment does not exist for this case, but wake attachment can occur. The system then looks for rules in which to satisfy a valuation for "wake_attachment". If wake attachment does not occur, other rules within the knowledge base will fire and a value "flow_type" (i.e. V2) will be assigned to "flow_class". If the knowledge base rules fire that conclude wake attachment with buoyant lift-off from the bottom, V2A1 will be assigned to "flow_type".

As an example of the output from CLASS, the following would represent some of the information presented for a discharge trapped by the pycnocline in a two-layer density stratified environment:

"The near field flow configuration will have the following features:

The specified two layer ambient density stratification is dynamically important. The discharge near field flow will be confined to the lower layer by the ambient density stratification. Furthermore, it is trapped in the lower layer by the ambient density jump at the pycnocline.

The following conclusion on the flow configuration applies to the lower layer only of the specified ambient stratification condition B.

Note that the lower layer will be overlaid by the surface layer of the ambient density stratification. The surface layer will remain undisturbed by the near field discharge flow (with the exception of some possible intrusion along the pycnocline).

The flow class is V2 for the design case represented by the DOS file name EXAMPLE."

A detailed hydrodynamic description of the flow is available to the user in the knowledge base sub-element FLOWDES. This detailed output includes a description of the significant near field mixing processes, or the hydrodynamic mixing zone (HMZ). The complete listing of the flow descriptions for all major flow classes is contained in Appendix C. Typically, the HMZ is the region of strong initial mixing where the particular design of the outfall can have an effect on initial dilution. The HMZ is defined to give additional information as an aid to understanding mixing processes and to distinguish it from purely legal mixing zone definitions.

CLASS also creates a cache output file that supplies the next CORMIX1 element HYDRO with instructions for running the appropriate simulation. At its termination CLASS triggers the next program element HYDRO.

4.2.4 Hydrodynamic Simulation Element: HYDRO

HYDRO is a knowledge base that runs the hydrodynamic simulation program for the flow classification program specified in CLASS. The actual simulation program HYDRO is written in Fortran. The simulation program is based on the analytical description of the physical mixing processes presented in Chapter II and discussed in more detail in Chapter V.

HYDRO consists of control programs or "protocols" for each hydrodynamic flow classification (e.g. V1, S2, H3, etc.) as specified by CLASS. Each protocol executes a series of subroutines or "modules" corresponding to the flow phenomena (e.g. weakly deflected jet in crossflow (mdnf), surface spreading, etc.) which may occur in that flow classification. Thus HYDRO assembles the appropriate simulation sequence by picking the correct flow modules.

HYDRO creates a tabular output file of the simulation containing information on geometry (trajectory, width, etc.) and mixing (dilution, concentration). The user has the option to view the tabular output file. An example of such an output file is given in Appendix D.

At its termination HYDRO triggers the final program element SUM.

4.2.5 Hydrodynamic Simulation Summary Element: SUM

SUM is a VP-Expert program that summarizes the hydrodynamic simulation results for the case under consideration. SUM describes mixing characteristics, evaluates how applicable legal requirements are satisfied, and suggests possible design alternatives to improve dilution. Thus, SUM may be used as an interactive loop to guide the user back to DATIN to alter design variables.

The output of SUM is arranged in four groups; site summary, hydrodynamic simulation summary, data analysis, and design recommendations. The site summary gives the site identifier information, discharge and ambient environment data, and discharge length scales. The hydrodynamic simulation summary lists conditions at the end of the hydrodynamic mixing zone, legal mixing zone conditions, toxic dilution zone conditions, region of interest criteria,

upstream intrusion information, and bank attachment locations, if applicable. The data analysis section gives further details on toxic dilution zone criteria, legal mixing zone criteria, stagnant ambient environment information, and region of interest criteria. Finally, the design recommendations section gives suggestions for sensitivity studies and design changes for improving initial dilution. An example of a case summary and design recommendations appear in Appendix E.

At the completion of SUM, the user is given the option to exit to DOS, start a new design example, or modify the discharge and mixing zone data for the design case under consideration using the same general ambient data base.

Chapter V

CORMIX1: Flow Protocols and Simulation Modules

This chapter provides the hydrodynamic details of the effluent flow predictions and mixing zone analysis as performed in program element HYDRO of the expert system CORMIX1.

First, detailed flow protocols for each of the 35 flow classes defined in program element CLASS (see Section 3.2) are given. The full hydrodynamic description of these flow classes (which is available on-line to the system user) appears in Appendix C. In Section 5.2 the actual prediction modules for each flow zone, including near-field and far-field processes, are discussed. Finally, in Section 5.3 the appropriate transition criteria that define the spatial extent of each flow zone (module) are presented, along with all constants used in the flow classification and simulation modules.

5.1 Flow Protocols

The hydrodynamic prediction of the effluent flow and of associated mixing zones in program element HYDRO is carried out by appropriate flow modules that are executed according to a protocol that pertains to each distinct flow configuration as determined by the classification scheme CLASS.

CORMIX1 contains 22 separate flow modules that apply to each of the diverse mixing processes that can occur in the near- and far-field of an effluent discharge. The physical background of these mixing processes has been discussed in Chapter II. Table 5.1 summarizes the flow modules. A detailed description of each module is given in Section 5.2.

The sequence of module execution is governed by a flow protocol for each flow class. These flow protocols have been constructed on the basis of the same arguments that have been presented in Chapter III to develop the flow classification. Detailed flow protocols for each flow class are presented in the following sub-sections with extended explanations on their formulation.

The spatial extent of each flow module is governed by transition rules. These determine transitions between

Table 5.1 Flow Prediction Modules of CORMIX1

Module (MOD)	Description
<u>Modules for Buoyant Jet Near-Field Flows</u>	
01	zone of flow establishment (zofe)
11	weakly deflected jet in crossflow (mdnf)
12	weakly deflected wall jet in crossflow (mdnf-wj)
13	near-vertical jet in linear stratification (mdls-v)
14	near-horizontal jet in linear stratification (mdls-h)
16	strongly deflected jet in crossflow (mdff)
17	strongly deflected wall jet in crossflow (mdff-wj)
21	weakly deflected plume in crossflow (bdnf)
22	strongly deflected plume in crossflow (bdff)
<u>Modules for Boundary Interaction Processes</u>	
31	near-horizontal surface/bottom/pycnocline approach
32	near-vertical surface/bottom/pycnocline impingement with buoyant upstream spreading
33	near-vertical surface/bottom/pycnocline impingement with vertical mixing
34	near-vertical surface/bottom/pycnocline impingement, upstream spreading, vertical mixing, and buoyant restratification
36	terminal layer stratified impingement/upstream spreading
37	terminal layer injection/upstream spreading

Table 5.1 (Continued)

Module (MOD)	Description
<u>Modules for Buoyant Spreading Processes</u>	
41	buoyant layer spreading in uniform ambient
42	buoyant spreading in linearly stratified ambient
<u>Modules for Attachment/Detachment Processes</u>	
51	wake recirculation
52	lift-off/fall-down
<u>Modules for Ambient Diffusion Processes</u>	
61	passive diffusion in uniform ambient
62	passive diffusion in linearly stratified ambient

different near-field and far field mixing regions, and distances to boundary interaction. Section 5.3 gives a detailed summary of the transition rules.

5.1.1 Flow Protocols for Buoyant Discharges into Uniform Ambient Layers (Flow Classes V and H)

The classification scheme discussed in Section 3.2.3 with its associated criteria (see Figure 3.5) already gives an indication of which flow processes will occur for each of the flow classes, and hence which sequence of flow modules is necessary for simulation. The length scales are the basis for the sequence determination in the near-field. As an example, consider flow class V1. In the submerged phase of that flow there are four possible flow zones (i.e. mdnf, mdff, bdnf, or bdff) that might be involved. The question is, which will occur and in what sequence? Provided that L_m and L_b are both substantially larger than L_0 , two possible transitions can occur (see Figure 5.1):

i) For $L_m/L_b \gg 0(1)$ the buoyancy in the plume is relatively weak compared to momentum, and a large distance is required for the buoyancy to generate additional momentum to control flow characteristics. Therefore the flow will develop as: mdnf \rightarrow mdff \rightarrow bdff. This is the initial sequence for the subsurface flow modules in flow class V1.

ii) If $L_m/L_b \ll 0(1)$, the buoyancy force is much stronger and the flow will be a weakly deflected jet when buoyancy forces begin to dominate. Therefore the flow will develop as: mdnf \rightarrow bdnf \rightarrow bdff. This is an alternate initial sequence (labeled V1') which has not been illustrated in Figure 3.4.

In each of the preceding cases boundary interaction interrupts the sequence of flow regions. When boundary interaction occurs, the sequence will change to include the appropriate boundary interaction effect and then continue as a surface far-field flow. The listing of the flow protocols for the flow categories V and H is given in Table 5.2.

No protocols are given for flow classes H4-180, H5-90, and H5-180. These discharge types lead to a complicated, irregular, and perhaps time-dependent (pulsating) flow behavior for which no reliable predictive methodology exists and which also seem undesirable in engineering practice.

Additional criteria are also imbedded into the actual flow modules which may lead to by-pass of certain flow

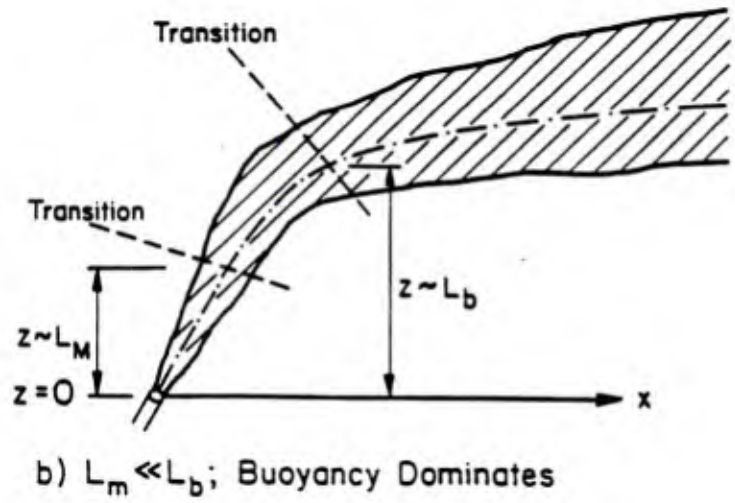
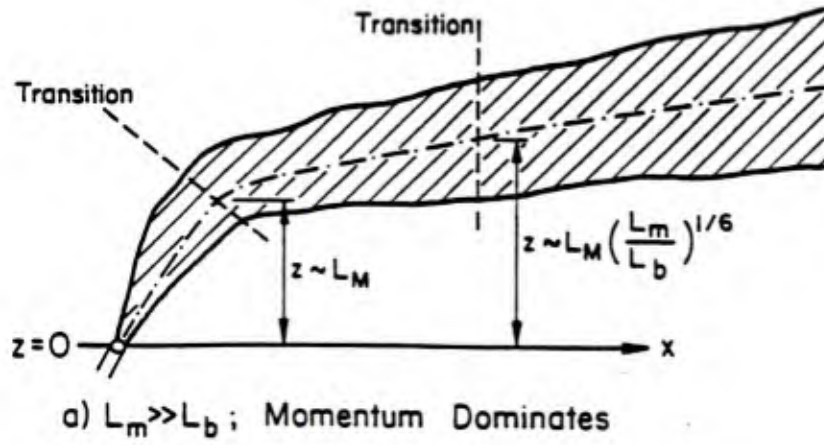

General Behavior for Buoyant Jets in Unconfined Crossflow (Assuming Near-Vertical Discharge)

Figure 5.1 General Behavior for Buoyant Jet in Unconfined and Unstratified Crossflow

Table 5.2 Flow Protocols for Buoyant Discharges into Uniform Ambient Layers

Flow Class	Flow Zone	MOD	TR
V1,H1	discharge	01	0
	mdnf	11	1
	bdnf	21	3
	bdff	22	5
	surface approach	31	10
	surface buoyant spreading	41	17
	passive diffusion	61	
V1',H1'	discharge	01	0
	mdnf	11	2
	mdff	16	4
	bdff	22	5
	surface approach	31	0
	surface buoyant spreading	41	7
	passive diffusion	61	
V2,H2	discharge	01	0
	mdnf	11	2
	mdff	16	5
	surface approach	31	0
	surface buoyant spreading	41	7
	passive diffusion	61	

MOD = module, TR = transition rule

Table 5.2 (continued)

Flow Class	Flow Zone	MOD	TR
V3, H3	discharge	01	0
	mdnf	11	1
	bdnf	21	6
	surface impingement with buoyant upstream spreading	32	0
	surface buoyant spreading	41	7
	passive diffusion	61	
V4	discharge	01	0
	mdnf	11	5
	surface impingement with full vertical mixing	33	0
	surface buoyant spreading	41	7
	passive diffusion	61	
V5, H4-0 H4-90	discharge	01	0
	mdnf	11	1
	bdnf	21	6
	surface impingement with buoyant upstream spreading	32	0
	surface buoyant spreading	41	7
	passive diffusion	61	

Table 5.2 (continued)

Flow Class	Flow Zone	MOD	TR
H5-0	discharge	01	0
	mdnf-wj	12	9
	surface impingement with full vertical mixing	33	0
	surface buoyant spreading	41	7
	passive diffusion	61	
V6	discharge	01	0
	surface impingement with unstable recirculation, full vertical mixing, buoyant upstream spreading, and buoyant restratification	34	0
	surface buoyant spreading	41	7
	passive diffusion	61	

modules. For example, if the source dimension is large and the crossflow is strong, i.e. $L_s \gg L_m$, then the weakly deflected jet (MOD11) may be omitted in some flow classes, and a strongly deflected jet or plume may follow the initial discharge. For a non-buoyant discharge, the buoyant spreading regime (MOD41) will be absent in the applicable flow classes (V2 or H2). Given all these possible subclasses the actual variety of flow configurations that will be modeled is much larger than indicated by the primary classes (see also Section 3.2)

5.1.2 Flow Protocols for Negatively Buoyant Discharges into Uniform Ambient Layers (Flow Classes NV and NH)

The flow protocols for negatively buoyant discharges into uniform ambient layers, corresponding to the flow classes NV and NH as discussed in Section 3.2.4 and illustrated in Figure 3.6, are listed in Table 5.3. Some of the unstable discharge protocols bear some resemblance to those for positively buoyant discharges except for restratification and buoyant spreading in the far-field. This is reflected in different transition criteria.

Also some protocols for stable discharge classes (e.g. NV1, NH1) appear similar to their positively buoyant counterpart (e.g. V1, H1). However, some differences in transition criteria as well as the downward acting buoyancy force act to produce entirely different flow configurations (see sketches in Figures 3.5 and 3.6, respectively).

5.1.3 Flow Protocols for Discharges Trapped in Linearly Stratified Ambients (Flow Class S)

Table 5.4 summarizes the protocols for the five flow classes S (refer to Section 3.2.2 and Figure 3.4) in which the ambient stratification causes an internal trapping of the effluent flow leading to a terminal layer formation and subsequent far-field processes. All stratification dominated flow (see Fig. 3.4) use special modules that account for the ambient stratification in the initial jet or plume phases of the flow.

For instance, in the jet-like stratification dominated flows (classes S2, and S3) the mdnf will be replaced by its stratified counterpart, the mdls, before terminal layer interaction.

When terminal layer interaction occurs the normal sequence of flow regions is interrupted, and the sequence will change to include the appropriate terminal layer interaction (see Section 3.2.2) and then continue as an

Table 5.3 Flow Protocols for Negatively Buoyant Discharges into Uniform Ambient Layers

Flow Class	Flow Zone	MOD	TR
NV1	discharge	01	0
	mdnf	11	2
	mdff	16	16
	bdff	22	17
	bottom approach	31	0
	bottom buoyant spreading	41	7
	passive diffusion	61	
NH1	discharge	01	0
	mdnf	11	16
	bdff	22	17
	bottom approach	31	0
	bottom buoyant spreading	41	7
	passive diffusion	61	
NV2,NH2	discharge	01	0
	mdnf	11	16
	bdnf	21	17
	bottom impingement with buoyant upstream spreading	32	0
	bottom buoyant spreading	41	7
	passive diffusion	61	

MOD = module, TR = transition rule

Table 5.3 (continued)

Flow Class	Flow Zone	MOD	TR
NV3	discharge	01	0
	mdnf	11	1
	mdff	16	5
	surface approach	31	0
	fall down	52	0
	bdff	22	17
	bottom approach	31	0
	bottom buoyant spreading	41	7
	passive diffusion	61	
NH3	discharge	01	0
	mdnf	11	2
	bdnf	21	17
	bottom approach	31	0
	mdnf-wj	12	18
	flow turning	31	0
	bottom buoyant spreading	41	7
	passive diffusion	61	
NV4	discharge	01	0
	mdnf	11	5
	surface impingement with full vertical mixing	33	0
	surface buoyant spreading	41	7
	passive diffusion	61	

Table 5.3 (continued)

Flow Class	Flow Zone	MOD	TR
NH4	discharge	01	0
	mdnf	11	2
	mdff	16	16
	bdff	22	17
	bottom approach	31	0
	bottom buoyant spreading	41	7
	passive diffusion	61	
NV5	discharge	01	0
	bottom impingement with unstable recirculation, full vertical mixing, buoyant upstream spreading, and buoyant restratification	34	0
	bottom buoyant spreading	41	7
	passive diffusion	61	
NH5	discharge	01	0
	mdnf	11	5
	bottom impingement with full vertical mixing	33	0
	surface buoyant spreading	41	7
	passive diffusion	61	

Table 5.4 Flow Protocols for Discharges Trapped in Linearly Stratified Ambients

Flow Class	Flow Zone	MOD	TR
S1	discharge	01	0
	mdnf	11	2
	mdff	16	10
	terminal layer approach	31	0
	internal buoyant spreading	42	11
	passive stratified layer		
	diffusion	62	
S2	discharge	01	0
	mdls-v	13	12
	terminal layer impingement with upstream spreading	36	0
	internal buoyant spreading	42	11
	passive stratified layer		
	diffusion	62	
S3	discharge	01	0
	mdls-h	14	13
	terminal layer injection with buoyant upstream spreading	37	0
	internal buoyant spreading	42	11
	passive stratified layer		
	diffusion	62	

MOD = module, TR = transition rule

Table 5.4 (Continued)

Flow Class	Flow Zone	MOD	TR
S4	discharge	01	0
	mdnf	11	1
	bdnf	21	3
	bdff	22	14
	terminal layer approach	31	0
	internal buoyant spreading	42	11
	passive stratified layer		
	diffusion	62	
S5	discharge	01	0
	mdnf	11	1
	bdnf	21	15
	terminal layer impingement with		
	buoyant upstream spreading	36	0
	internal buoyant spreading	42	11
	passive stratified layer		
	diffusion	62	

internal layer far-field flow.

5.1.4 Flow Protocols for Bottom Attached Flows (Flow Classes (..)A)

The flow protocols corresponding to Section 3.2.5 and Figure 3.7 are listed in Table 5.5. The first flow module following the discharge refers to either wake recirculation for wake attachment classes (A1 and A2); or to wall jet flow for Coanda attachment classes (A3 to A5). Flow class A3 has a sub-class A3' (determined by using an internal criterion) depending on whether a weakly deflected jet flow (MOD17) exists. Whenever a lift-off occurs due to positive buoyancy the remaining flow regimes after lift-off are similar to the parent flow class given by the prefix (..).

For wake attached jets, the near-field flow regimes are replaced by a wake-recirculation module as described in Section 5.3.3.8. In the (..)A1 class, buoyancy is sufficient to cause lift off, so the wake recirculation is followed by a bdf. For negatively buoyant flow classes with no lift off ((..)A2 class), the wake recirculation can be followed by a buoyant bottom spreading module.

In the Coanda attached jet, the usual mdnf and mdff are replaced by their attached counterparts, the mdnf-wall jet and the mdff-wall jet, respectively. If sufficient buoyancy is present, as in attachment classes A3, A3', and A4, lift-off will occur.

5.2 Hydrodynamic Simulation Modules

This section provides the salient details for each of the modules listed in Table 5.1 which provide the predictive element for a particular mixing process. The modules are grouped into the different flow phases (from near-field to far-field) as indicated in Table 5.1

There are two types of flow modules:

- i) The continuous types describe the evolution of a flow process along a trajectory. Depending on user input, a small or large step interval can be used to obtain flow and mixing information along that trajectory.
- ii) The control volume type uses a control volume approach to describe outflow values as a function of inflow values based on conservation principles.

For either type, the beginning values are denoted by the subscript "i" (e.g. S_i is beginning dilution) and final

Table 5.5 Flow Protocols for Bottom Attached Flows

Flow Class	Flow Zone	MOD	TR
(..)A1	discharge	01	0
	wake recirculation	51	0
	lift-off	52	0
	bdff	22	5
	surface approach	31	0
	surface buoyant spreading	41	7
	passive diffusion	61	
(..)A2	discharge	01	0
	wake recirculation	51	0
	bottom buoyant spreading (NV and NH only)	41	7
	passive diffusion	61	
(..)A3	discharge	01	0
	mdnf-wj	12	18
	lift-off	52	0
	bdff	22	5
	surface approach	31	0
	surface buoyant spreading	41	7
	passive diffusion	61	

MOD = module, TR = transition rule

Table 5.5 (continued)

Flow Class	Flow Zone	MOD	TR
(..)A4	discharge	01	0
	mdnf-wj	12	8
	lift-off/fall down	52	0
	bdnf	21	6
	surface impingement with buoyant upstream spreading	32	0
	surface buoyant spreading	41	7
	passive diffusion	61	
(..)A5	discharge	01	0
	mdnf-wj	12	2
	mdff-wj	17	19
	surface approach	31	0
	surface buoyant spreading	41	7
	passive diffusion	61	

values are denoted by the subscript "f" (e.g. b_f is the final flow half-width).

5.2.1 Simulation Modules for Buoyant Jet Near-Field Flows

5.2.1.1 Introductory Comments

The flow equations in this module group describe the trajectory (x,y,z) of the jet/plume centerline and provide values along that trajectory for the flow half-width b , the local concentration c , and the local dilution S .

The half-width b is defined here as the "1/e width" as a typical convention for Gaussian jet-like profiles (see for example Holley and Jirka, 1986). Thus, b is the half-width (radius) of the jet/plume flow where the local concentration is $1/e$, or 37%, of the centerline concentration. Since alternate width definitions are sometimes used in pollution analysis, the width definition when multiplied by 0.83 gives the 50% width, by $1/2^{1/2}$ gives the standard deviation (61% width), and by $2^{1/2}$ gives the 14% width, respectively. In the case of atmospheric plumes the later definition is often taken as the "visual width" of the plume.

The local concentration in this group of modules refers to the maximum centerline concentration c_c at the jet/plume centerline. Thus, the corresponding dilution refers to the minimum dilution c_0/c_c in which c_0 is the initial discharge concentration. It is important to keep in mind these flow definitions since they differ, in general, from those found in modules for subsequent flow zones. These differences are unavoidable due to different profile shapes for the effluent flow distribution governed by the various mixing processes.

In CORMIX1 a global Cartesian coordinate system (x,y,z) is placed at the bottom of the water body with the origin $(0,0,0)$ located directly below the center of the discharge orifice. The height of the discharge orifice above the bottom is h_0 . The positive x-axis is located at the bottom and directed in the downstream direction following the ambient flow. The positive y-axis is located at the bottom and points to the left, normal to the ambient flow direction (x-axis). The positive z-axis points vertically upward. The angle between the discharge axis y^* and its projection on the horizontal plane (i.e. the discharge angle above horizontal) is θ_0 . The discharge-crossflow angle σ_0 is the angle between the projection of y^* on the x-y plane and the x-axis ($\sigma_0 = 0^\circ$ for co-flowing discharges, $\sigma_0 = 180^\circ$ for counter-flowing discharges).

A primed coordinate system, (x',y',z') , within a given buoyant jet flow region is specified with respect to the virtual source for that flow region. A virtual source is

needed for each flow region because the perturbation analyses used in each module assume a point discharge source, which is physically unrealistic. The primed coordinate system is related to the global coordinate by

$$(x, y, z) = (x', y', z') + (x_v, y_v, z_v) \quad (5.1)$$

where (x_v, y_v, z_v) is the global position of the virtual source for that flow region. The position of the virtual source (x_v, y_v, z_v) is computed by taking the known flow solution at the transition, as given from the previous flow region, and then back calculating the source position using the dilution equation for the given flow region. This procedure assures continuity of the dilution and concentration predictions from one module to another. However, occasionally slight discontinuities in the predicted half-widths can occur.

In general, the simple analytical results of Chapter II are extended to non-vertical three dimensional trajectories within the ambient crossflow. A supplementary transverse coordinate η is defined here in a plane given by the z-axis and η is the projection of y' into the z-y plane. Any vertical motion of the jet flow is controlled by the vertical component of the discharge momentum flux as well as the buoyancy flux (which always acts vertically). The transverse (horizontal) motion of the jet flow is solely controlled by the horizontal component of the discharge momentum flux.

Defining γ_0 as the angle between the discharge axis y' and the crossflow (x-axis), and the angle δ_0 between the projection of y' on the yz-plane (transverse coordinate η) and the y-axis the relationships for the discharge angles θ_0 and σ_0 are

$$\gamma_0 = \sin^{-1}(1 - \cos^2\theta_0 \cos^2\sigma_0)^{1/2} \quad (5.2)$$

$$\delta_0 = \tan^{-1}(\tan\theta_0/\sin\sigma_0) \quad (5.3)$$

5.2.1.1 Discharge Module (MOD01)

This module begins every flow sequence. In the module the flow is converted from a uniform velocity distribution to a Gaussian profile, with equivalent volume flux (note that momentum flux conservation is assured due to the bulk flow parameters used in the analysis). The representative final flow width b_f for the discharge module is

$$b_f = (a_0/\pi)^{1/2} \quad (5.4)$$

where a_0 is the port cross sectional area. No dilution is assumed to occur, so that $S_f = 1.0$ and $c_f = c_0$, where S_f is

final dilution and c_f and c_0 are the final and discharge concentrations, respectively. The final x- and y-coordinate are 0, but $z_f = h_0$.

5.2.1.2 Weakly Deflected Jet In Crossflow (MOD11, mdf)

The results for the mdf presented in Section 2.1.4.1 are extended to include the general 3-D trajectory. For a cross-flowing discharge ($\gamma_0 > 45^\circ$) the trajectory is a function of η as the independent variable. Writing the trajectory equations in the virtual coordinate system for the mdf in terms of the supplemental coordinate η gives the crossflow induced deflection

$$x' = \eta' \cot \gamma_0 + \eta'^2 / (T_{11}^2 L_m) \quad (5.5)$$

where T_{11} is the trajectory constant for the mdf. The expression for the transverse coordinate y is simply

$$y' = \eta' \cos \delta_0 \quad (5.6)$$

The vertical coordinate, however, experiences an additional perturbation due to buoyant deflection, or

$$z' = \eta' \sin \delta_0 + T_{11B} \eta'^3 \text{sign} J_0 / (L_m^2 \sin^3 \gamma_0) \quad (5.7)$$

where T_{11B} is a constant for the buoyancy correction in the mdf, and $\text{sign} J_0$ is equal to +1 for a positively buoyant discharge and is equal to -1 for a negatively buoyant discharge.

The flow width (radius) is

$$b = B_{11} \eta' / \sin \gamma_0 \quad (5.8)$$

where B_{11} is a width constant for the mdf. The dilution is expressed as

$$S = S_{11} \eta' / (L_0 \sin \gamma_0) \quad (5.9)$$

where S_{11} is the dilution constant.

If the discharge is co-flowing ($\gamma_0 \leq 45^\circ$), the simulation should step in x as the primary independent coordinate and the trajectory, width, and dilution relationships are

$$z' = \eta' \sin \delta_0 + T_{11B} x'^3 \text{sign} J_0 / (L_m^2 \cos^3 \gamma_0) \quad (5.10)$$

$$\eta' = x' \tan \gamma_0 - x'^2 \tan \gamma_0 / (T_{11}^2 L_m) \quad (5.11)$$

$$b = B_{11} x' / \cos \gamma_0 \quad (5.12)$$

$$S = S_{11}x' / (L_0 \cos \gamma_0) \quad (5.13)$$

5.2.1.3 Weakly Deflected Wall Jet in Crossflow (MOD12, mdnf-wj)

In this flow region unequal entrainment and spreading will be neglected in directions parallel and normal to the boundary wall. The attached flow has a horizontal momentum flux M_w two times the discharge momentum flux M_0 to account for the mirror image of the attached flow with the bottom symmetry plane, so the horizontal wall momentum flux $M_w = 2M_0 \cos \theta_0$. This assumption also results in $Q_w = 2Q_0$.

For a cross-flowing discharge ($\sigma_0 > 45^\circ$), the trajectory equation for y' in terms of x' ($z = 0$ for the attached case) becomes

$$y' = T_{12} (2 \cos \theta_0)^{1/4} L_m^{1/2} (x' - y' \cot \sigma_0)^{1/2} \quad (5.14)$$

where T_{12} is a trajectory constant for the mdnf-wj. The width and dilution are given by

$$b = B_{12} y' / \sin \sigma_0 \quad (5.15)$$

$$S = S_{12} y' (\cos \theta_0 / 2)^{1/2} / (L_0 \sin \sigma_0) \quad (5.16)$$

respectively, where B_{12} a width constant, and S_{12} is a dilution constant for the mdnf-wj. A similar equation system holds for the co-flowing wall jet ($\sigma_0 < 45^\circ$) in analogy to the free jet (previous sub-section).

5.2.1.4 Near-Vertical Jet in Linear Stratification (MOD13, mdls-v)

For jets issued (near-)vertically into a density stratified environment, γ_0 is greater than 45° so the xyz-coordinates of the flow in the virtual coordinate system are given in first order by a straight line trajectory

$$x' = \eta' \cot \gamma_0 \quad (5.17)$$

$$y' = \eta' \cos \delta_0 \quad (5.18)$$

$$z' = \eta' \sin \delta_0 \quad (5.19)$$

respectively. The width and dilution are expressed as

$$b = B_{13} \eta' / \sin \gamma_0 \quad (5.20)$$

$$S = S_{13} [(1 - S_{13A} \sin^2 \theta_0 \eta'^4 / (\sin^4 \gamma_0 L_m'^4)] \eta' / (L_0 \sin \theta_0) \quad (5.21)$$

respectively, where B_{13} is a width constant, and S_{13} and S_{13A} are dilution constants for the mdls-v. For the physical background see Section 2.2.4.7.

5.2.1.5 Near-Horizontal Jet in Linear Stratification (MOD14, mdls-h)

The simulation of this module (occurring in flow classes S3) is limited to the co-flowing design, with γ_0 less than 45. The trajectory in the virtual coordinate system is given by

$$z' = x' \tan \gamma_0 \sin \delta_0 + [T_{148} L_b'^4 / (L_m' \cos^{1/4} \theta_0)]^3 \quad (5.21)$$

$$\text{sign} J_0 [(\eta' - \eta_i') / (\eta_i' - \eta_i')]^2$$

$$y' = x' \cos \delta_0 \tan \gamma_0 \quad (5.22)$$

respectively, where the second factor of Eq. 5.21 describes the added deflection due to buoyancy flux. The width and dilution are given by

$$b = B_{14} x' / \cos \gamma_0 \quad (5.23)$$

$$S = S_{14} x' / L_0 \cos \gamma_0 \quad (5.24)$$

where B_{14} is a width constant.

5.2.1.6 Strongly Deflected Jet In Crossflow (MOD16, mdff)

In the mdff the primary variable is x' due to the crossflow advection. The trajectory equations are

$$z' = \eta' \sin \delta_0 + T_{168} L_b'^{1/3} x'^{2/3} \text{sign} J_0 \quad (5.25)$$

$$\eta' = T_{16} L_m'^{2/3} \sin^{1/3} \gamma_0 x'^{1/3} \quad (5.26)$$

where T_{16} is the trajectory constant, and T_{168} in the second factor of Eq. (5.25) is a constant for the buoyant perturbation correction to the mdff flow. The y-coordinate is similar to the mdnf in a crossflow.

The width and dilution of the flow are given by

$$b = B_{16} \eta' \quad (5.27)$$

$$S = S_{16} \eta'^2 / (L_m L_0) \quad (5.28)$$

respectively.

5.2.1.8 Strongly Deflected Wall Jet in Crossflow (MOD17, mdff-wj)

The assumption for jet attached momentum flux M_w is the same as in previous section for the mdnf-wj. Expressing the trajectory equations for y' in terms of x' ($z = 0$ for the attached case) gives in analogy to the free jet

$$y' = T_{17}(2\cos\theta_0)^{2/3}L_m^{2/3}(\sin\sigma_0)^{1/3}x'^{1/3} \quad (5.29)$$

The dilution is

$$S = S_{14}y'^2/(2L_mL_b) \quad (5.30)$$

where S_{14} is a dilution constant.

5.2.1.4 Weakly Deflected Plume in Crossflow (MOD21, bdnf)

The bdnf trajectory coordinates are a generalization of the perturbation solutions presented in Section 2.1.4.6. With z' as the primary coordinate the trajectory equations are

$$x' = (z'/(T_{21}L_b^{1/4}))^{4/3} + \quad (5.31)$$

$$\begin{aligned} & (T_{16}L_m\cos^{3/4}\theta_0 - t_{21M1}L_m^{4/3}\cos\theta_0/z'^{1/3})\cos\sigma_0 \\ y' = & T_{21}L_m^{2/3}\cos^{1/3}\theta_0\sin^{1/3}\sigma_0x'^{1/3} + \quad (5.32) \\ & (T_{21M2}L_m\cos^{3/4}\theta_0 - t_{21M1}L_m^{4/3}\cos\theta_0/z'^{1/3})\sin\sigma_0 \end{aligned}$$

where T_{21} is a trajectory constant for the bdnf, and T_{21M1} and T_{21M2} are momentum correction coefficients. Width and dilution are given by

$$b = B_{21}z' \quad (5.33)$$

$$S = S_{21}L_b^{1/3}z'^{5/3}/(L_mL_b) \quad (5.34)$$

respectively, where B_{21} is a width constant and S_{21} is a dilution constant for the bdnf.

5.2.1.9 Strongly Deflected Plume in Crossflow (MOD22, bdff)

The bdff trajectory coordinates, written in the virtual coordinate system as a function of x' are

$$z' = T_{22}L_b^{1/3}x'^{2/3}\text{sign}J_0 \quad (5.35)$$

$$y' = T_{16}L_m^{2/3}\cos^{1/3}\theta_0\sin^{1/3}\sigma_0x'^{1/3} \quad (5.36)$$

where T_{22} is a constant for the bdiff, and T_{16} is a constant for the mdff since the transverse deflection is momentum induced.

Width and dilution are given by

$$b = B_{22}z' \quad (5.37)$$

$$S = S_{22}z'^2 / (L_m L_0) \quad (5.38)$$

respectively.

5.2.2 Simulation Modules for Boundary Interaction Processes

When the flow interacts with any boundary such as the surface, bottom, or pycnocline density jump, a similar interaction module will be used to describe the process. The only difference is the centerline height of the flow as well as any hydrostatic adjustment process for pycnocline flows (see Section 2.23).

In all of the following modules a control volume approach is used. Generally, a bell-shaped jet/plume inflow is transformed to a more uniform (top-hat) outflow zone that follows the boundary (surface, bottom, pycnocline) or flows in the stratified terminal layer. Thus, after transformation the final geometric values are the trajectory (x_f, y_f, z_f) , the total vertical thickness b_{vf} , and the horizontal half-width b_{hf} of the top-hat profile. Also concentration and dilution values refer to average values which, within the top hat profile, tend to be close to extreme (maximum or minimum, respectively) values.

5.2.2.1 Near-Horizontal Surface/Bottom/Pycnocline Approach (MOD31)

In this simplest approach condition, the bent over flow approaches the interface near-horizontally at impingement angle $\theta_i < 45^\circ$ (Figure 2.8a and Section 2.4.1).

The final x-coordinate is given by a geometric shift due to the size of the in-flowing jet/plume

$$x_f = x_i + 2b_i \quad (5.39)$$

y_f is set equal to y_i , and z_f equal to z_i . The final bulk dilution is

$$S_f = SB_{31}S_i \quad (5.40)$$

where SB_{31} is a bulk mixing conversion factor.

5.2.2.2 Near-Vertical Surface/Bottom/Pycnocline Impingement with Buoyant Upstream Spreading (MOD32)

In this surface approach condition, the weakly bent flow impinges on the surface at a near-vertical angle θ_i , where $\theta_i > 45^\circ$. The physical process has been summarized in Section 2.42 with reference to Figure 2.8.b. After impingement the flow spreads more or less radially along the water surface as a density current. In particular, the flow spreads some distance upstream against the ambient flow, and laterally across the ambient flow. This spreading is dominated by the strong buoyancy of the discharge.

The dilution is expressed as (see Eq. 2.85)

$$S_f = S_i S_{SB32} [L_b / (H_s (1 - \cos\theta_i \cos\sigma_i))]^{1/3} \quad (5.41)$$

where S_{SB32} is a dilution constant. The upstream intrusion length L_s is given by

$$L_s = AL_{32A} L_b (1 - \cos\theta_i \cos\sigma_i)^{2/3} / (L_b / H_s)^{2/3} \quad (5.42)$$

for $(L_b / H_s) \leq 165(1 - \cos\theta_i \cos\sigma_i)$

and

$$L_s = AL_{32B} L_b \quad (5.43)$$

for $(L_b / H_s) > 165(1 - \cos\theta_i \cos\sigma_i)$

where AL_{32A} and AL_{32B} are constants. The typical vertical thickness within the upstream stagnation region is

$$h_s = CD_{32} S_f L_m L_b / L_b \quad (5.44)$$

where CD_{32} is a constant. The dimensions of the effluent flow are

$$b_{hf} = BH_{32} L_s \quad (5.45)$$

$$b_{vf} = S_f L_m L_b / (2b_{hf}) \quad (5.46)$$

The final flow coordinates are $x_f = x_i + 0.5b_{vf}$, $y_f = y_i$, and $x_f = x_i$.

5.2.2.3 Near-Vertical Surface/Bottom/Pycnocline Impingement with Full Vertical Mixing (MOD33)

In this surface approach region, the weakly bent flow impinges on the water surface at a near-vertical angle (Figure 2.8c). Because of the unstable recirculating flow, the centerplane dilution increases

$$S_f = SR_{33}S_i \quad (5.47)$$

where SR_{33} is a recirculation factor. The final flow width, b_{hf} , is found from the continuity equation

$$b_{hf} = S_f L_m L_b / (2H_s) \quad (5.58)$$

and final outflow location x_f is approximated as

$$x_f = x_i + H_s \quad (5.49)$$

where x_i is the plume position at the beginning of the region, and $y_f = y_i$ and $z_f = z_i$.

5.2.2.4 Near-Vertical Surface/Bottom/Pycnocline Impingement with Unstable Recirculation, Buoyant Restratisation, and Upstream Spreading (MOD34)

In this surface approach region, the flow rises near-vertically and impinges on the water surface (Figure 2.8d). After impingement the mixed flow recirculates over the limited water depth and becomes partially re-entrained into the flow. The final dilution S_f is given by

$$S_f = S_{34} H_s^{5/3} / (L_m^{2/3} L_b) \quad (5.50)$$

where S_{34} is a dilution constant. The upstream intrusion length L_s is given by

$$L_s = AL_{34} L_b \quad (5.51)$$

The upstream intrusion thickness h_s is

$$h_s = CD_{34} S_f L_m L_b / L_b \quad (5.52)$$

The final half-width b_{hf} and thickness b_{vf} and coordinates are analogous to those for MOD32.

5.2.2.5 Stratified Terminal Layer Impingement with Buoyant Upstream Spreading (MOD36)

In this condition, the flow becomes trapped in a stratified terminal layer before surface contact. This

terminal layer approach is defined for near-vertical, strongly buoyant stratified flows that do not interact with the surface or pycnocline density jump. The detailed equations are similar to the previously presented unstratified case (MOD32) and are not presented here.

5.2.2.6 Stratified Near-Vertical Surface Injection with Upstream Spreading (MOD37)

This module simulates a terminal layer approach for near-horizontal, strongly stratified jet-like flows that do not interact with the surface or pycnocline density jump. With the exception of an added effect on the horizontal discharge momentum, the development is similar to MOD36 and is omitted for brevity.

5.2.3 Simulation Modules for Buoyant Spreading Processes

The flow distribution inherent in the two buoyant spreading modules is again mostly uniform (top-hat). Hence, the same interpretations on geometric (width) and dilution (or concentration) values apply (see introductory comments to Section 5.2.2).

5.2.3.1 Buoyant Surface/Bottom Spreading (MOD41)

The physical background for buoyant spreading process at the boundary of an flowing ambient was discussed in Section 2.2.1. Thus the flow equations are

$$b_h = [b_{hi}^{3/2} + 1.5(L_v/(2CD_{v1}))^{1/2}(x - x_i)]^{2/3} \quad (5.53)$$

$$b_v = b_{vi} (b_h/b_{hi})^{\beta-1} \quad (5.54)$$

$$S = S_i (b/b_{vi})^{\beta} \quad (5.55)$$

The trajectory is a straight line following the ambient flow and located at the appropriate vertical boundary. Also, if the plume contacts a lateral boundary (shoreline) the trajectory centerline shifts over to that boundary and the further spreading process is limited to one frontal zone. These coordinate switching functions are included in MOD41.

5.2.3.2 Buoyant Terminal Layer Spreading (MOD42)

Referring to Section 2.8.4, the flow equations are

$$b_h = [b_{hi}^{2-\beta} + (2-\beta)(2CD_{42})^{-1/2} L_w/L_m'^2 b_{vi}/b_{hi}^{\beta-1} (x-x_1)]^{1/(2-\beta)} \quad (5.56)$$

$$b_v = b_{vi} (b_h/b_{hi})^{\beta-1} \quad (5.57)$$

$$S = S_i b_v b_h / (b_{vi} b_{hi}) \quad (5.68)$$

MOD42 also contains boundary interaction features.

5.2.4 Simulation Modules for Attachment/Detachment Processes

The variable definitions in the following section are similar to those for jet/plume processes (Section 5.2.1).

5.2.4.1 Wake Recirculation (MOD51)

This module describes the recirculation process for wake attached flows (see Section 2.4.4.1). The flow equations are for minimum dilution

$$S_f = \pi/2 b_{vf}^2 / (L_m L_0) \quad (5.69)$$

the flow half-width

$$b_{hf} = BV_{51} x_f \quad (5.70)$$

with $b_{vf} = b_{hf}$, and the longitudinal extent

$$x_f = XR_{51} (h_0 L_0) \quad (5.71)$$

5.2.4.1 Lift-Off/Fall-Down (MOD52)

This is the reverse of MOD31 and performs a conversion from a uniform (top-hat) profile to a final Gaussian profile as a buoyant plume separates from a boundary.

5.2.5 Simulation Modules for Ambient Diffusion Processes

The physical processes underlying the two ambient diffusion modules have been presented in Section 2.3. The following flow definitions apply here: The passive plumes have a Gaussian profile, the vertical thickness b_v and horizontal half-width represent the 46% width value (i.e. $(\pi/2)^{1/2}$ times the standard deviation of the Gaussian passive

diffusion profile). This width convention is equal to the width of a top-hat profile that has the same centerline concentration. This difference relative to the jet/plume regimes arises due to the different mass flux conservation equations for passive versus active (discharge induced) effluent flows. The representative concentration is the maximum centerline concentration, and the dilution is the corresponding minimum.

5.2.5.1 Passive Diffusion in Uniform Ambient (MOD61)

The passive plume trajectory is straight following the ambient flow. The geometric expressions are

$$b_v = [\pi E_z(x-x_i)/u_a + b_{vi}^2]^{1/2} \quad (5.72)$$

$$b_h = [\pi E_y(x-x_i)/u_a + b_{hi}^2]^{1/2} \quad (7.73)$$

with the appropriate diffusion coefficients E_z and E_y discussed in Section 2.31 for bounded channel flow. In unbounded channel flow, the "4/3 diffusion law" coefficient (Section 2.3.3) is used, and Eq. (2.65) is the expression for the half-width b_h . Changes in centerline trajectories occur when the plume interacts with vertical or lateral boundaries.

5.3.5.4 Passive Diffusion in Stratified Ambient (MOD62)

The flow expression for this module are analogous to MOD61 with the substitutions of a Richardson number dependence for the vertical diffusivity (Section 2.3.3). Also there are more complex interaction possibilities with vertical boundaries.

5.3 Transition Rules, Flow Criteria and Coefficient Values

This section provides the detailed equations for the transition rules listed in the flow protocols that control the spatial extent of each flow module. It also provides the complete functional form for the criteria, including terminal height evaluations that have been used in the flow classification presented in Chapter III. Furthermore, a listing and justification of all numerical coefficients is supplied.

5.3.1 Transition Rules

Transition rules are needed to give the spatial expressions as to where each flow region ends. Each subsequent flow region is assigned initial values that correspond to the final values of the preceding flow region. Transition rules used in the simulation appear in Table 5.6, and the associated constant values appear in Table 5.7.

For example, Transition Rule 1 gives the final value of a weakly deflected jet coordinate when it is followed by a weakly deflected plume. The transition from one region to the other is characterized by the jet/plume length scale L_H . If the discharge angle relative to the x-axis is γ_0 , the final supplementary coordinate η_f' , and the final x-coordinate x_f' are given by Transition Rule 1 as

$$\eta_f' = CT1V1 \cdot L_H \quad \gamma_0 > 45^\circ \quad (5.74)$$

$$x_f' = CT1V2 \cdot L_H \quad \gamma_0 \leq 45^\circ \quad (5.75)$$

where CT1V1 and CT1V2 are constants (Constant for Transition rule 1, first Value and second Value, respectively).

Note that some transition rules apply within the primed coordinate system (limiting x_f' , y_f' , z_f' , or η_f') while others apply to the global coordinate system (limiting x_f , y_f , z_f , or η_f).

As shown in Table 5.6 the proper transition rule depends on the sequence of current flow module to next flow module. In general, flow transitions between flow regimes are smooth due to matching volumetric dilutions. There may occasionally be slight discontinuities in the predicted flow width.

5.3.2 Flow Classification Criteria

A summary of the detailed classification criteria that have been shown in "order of magnitude" form on Figures 3.4 to 3.7 is provided in Table 5.8. The labels C1, C2, etc. correspond to the labels used on those figures. The detailed criteria often contain factors (e.g. 0.8 that describes the thickness of a buoyant layer formation at a boundary after impingement) that effectively reduce the existence of certain flow zones which are being tested for. The values of the numerical constants are also included in the first column of Table 5.7 with reference or comments on how they were obtained.

Table 5.6 Transition Rules

TR CMOD NMOD Equation

1	11	21	$\gamma_0 \geq 45^\circ$	$\eta_f' = CT1V1 \cdot L_M$
			$\gamma_0 < 45^\circ$	$x_f' = CT1V2 \cdot L_M$
2	11	16	$\gamma_0 \geq 45^\circ$	$\eta_f' = CT2V1 \cdot L_M \sin^{1/2} \gamma_0$
	12	17	$\gamma_0 < 45^\circ$	$x_f' = CT2V1 \cdot L_M \cos^{1/2} \gamma_0$
3	21	22		$z_f' = CT3V1 \cdot L_b$
4	16	22		$x_f' = CT4V1 \cdot L_M (L_b/L_M)^{1/6}$
5	22	31		$z_f = H_s$
	16	31		
	11	33		
6	21	32		$z_f = 0.8H_s + 0.2h_0$
7	41	61		$x_f = x_i + (2^{3/2}/3) \cdot CD_{41}^{1/2}$ $(b_{hi}^{3/2}/L_b^{1/2}) \{ [(8.0L_b b_{vi}) / (S_i f L_M L_0 R_{fc})]^{3/2} - 1 \}$
8	17	52	$\sigma_0 \geq 45^\circ$	$y_f' = CT8V1 \cdot L_M$
	12	52	$\sigma_0 < 45^\circ$	$x_f' = CT8V2 \cdot L_M$

TR = Transition Rule, CMOD = Current module,
 NMOD = next module

Table 5.6 (continued)

TR CMOD NMOD Equation

9	12	33	$\sigma_0 \geq 45^\circ$ $y_f' = (H_s/B_{11}) \sin \sigma_0$ $\sigma_0 < 45^\circ$ $y_f' = (H_s/B_{11}) \cos \sigma_0$
10	16	31	$z_f = h_0 + CT10V1 \cdot L_m^{1/3} L_m'^{2/3} \sin \theta_0^{1/3} \text{sign} \theta_0$
11	42	62	$x_f = x_i + (2CD_{42})^{1/2} / (2-\beta) (L_m'^2 b_{hi} / L_m / b_{vi}) \cdot$ $\{ [(8/f/R_{fc})^{1/2} L_m b_{vi} / L_m'^2]^{(2-\beta)/(1-\beta)} - 1 \}$
12	13	36	$z_f = h_0 + CT13V3 \cdot L_b'^4 / L_m' + CT12V1 \cdot L_m' \cos \theta_0$
13	14	37	$\gamma_0 \geq 45^\circ$ $\eta_f' = CT13V1 \cdot L_m'$ $\gamma_0 < 45^\circ$ $x_f' = CT13V2 \cdot L_m'$
14	22	31	$z_f = h_0 + CT14V1 \cdot L_b^{1/9} L_b'^{8/9} \text{sign} J_0$
15	21	36	$z_f = h_0 + CT15V1 \cdot L_b' \text{sign} J_0$
16	11	22	$\gamma_0 \geq 45^\circ$ $\eta_f' = CT16V1 \cdot L_m$ $\gamma_0 < 45^\circ$ $x_f' = CT16V2 \cdot L_m$
17	22	31	$z_f = 0$
	21	31	
18	12	31	$\sigma_0 \geq 45^\circ$ $y_f' = CT18V1 \cdot L_m$
19	17	31	$x_f' = CT19V1 \cdot L_m (\cos \theta_0)^{1/2}$

Table 5.7 Coefficients Used In Transition Rules

Coefficient	Value	Data Source, References, or Comment
CT1V1, CT1V2	2.5	A) From trajectory and terminal height equations given by Wright (1977), List (1982), Wong (1984), and Holley and Jirka (1986).
CT2V1, CT2V2	2.0	See A
CT3V1	1.0	See A
CT4V1	2.7	See A
CT8V1, CT8V2	1.5	Sharp (1977), Sobey et al. (1988)
CT10V1	2.1	B) From terminal height equations given in List (1982) and Wong (1984) (See Table 5.8)
CT12V1	2.1	See B
CT13V1, CT13V2	3.0	See B
CT13V3	2.0	See B
CT14V1	2.6	See B
CT15V1	2.5	See B
CT16V1	1.75	See A
CT16V2	2.5	See A
CT18V1	1.5	See A
CT19V1	30.0	See A
R_{fc}	1.0	Critical flux Richardson number

Table 5.8 Flow Classification Criteria

Criterion and Value	Equation Used in CLASS	Data Sources, References, or Comments
C1 = 1.0	$L_m'/L_b' \geq C1$	A) From trajectory and terminal height equations given by Wright (1977), List (1982), Wong (1984), and Holley and Jirka (1986).
C2 = 1.8	$L_m/L_m' \geq C2$	See A
C3 = 3.0	$L_b/L_b' \geq C3$	See A
C4 = 0.65	$L_m/[0.8(H_s-h_0)] \geq C4$	See A
C5 = 0.65	$L_m/[0.8(H_s-h_0)] \geq C5$	See A
C6, C7, C8 = 1.0	$L_b/[0.8(H_s-h_0)] \geq (C6, C7, C8)$	See A
C9, C11 = 0.4	$L_b/[0.8(H_s-h_0)] \geq (C9, C11)$	See A
C10 = 2.0	$L_m/H_s \geq C10$	B) Lee and Jirka (1981)
C12, C13 = 0.65	$L_m/L_b \geq C(12, 13)$	See A
C14, C15, C16 = 4.3	$L_m/H_s \geq (C14, C15, C16)$	Sobey et al. (1988)
C17 = 0.55	$L_m/[0.8(H_s-h_0)] \geq C17$	See A

Table 5.8 (continued)

Criterion and Value	Equation Used in CLASS	Data Sources, References, or Comments
C18 = 0.4	$L_w/[0.8(H_s-h_0)]$ $\approx C18$	See A
C19, C22 = 0.6	L_w/L_M $\approx (C19, C22)$	See A
C20 = 1.0	$L_b/H_s \approx C20$	See B
C21 = 0.65	$L_w/H_s \approx C21$	See A
C23 = 0.65	$L_w/[0.8(H_s-h_0)]$ $\approx C23$	See B
C24 = 0.65	$L_w/H_s \approx C24$	See B
C25 = 2.5	$(L_w+h_0)/L_0$ $\approx C25$ $(L_b+h_0)/L_0$ $\approx C25$	Derived on basis of data comparison for wake attached jets/plumes
C26 = 1.0	$L_b^2/[S_f L_0 L_m (f/8)^2] \approx C26$	Richardson number criterion for buoyant lift-off
C27, C28 = 0.20	$\tan\theta_0+h_0/L_w$ $\approx (C27, C28)$	Knudsen and Wood (1990) Sharp (1977)
C29 = 1.0	$L_b/(0.8H_s)$	See B

5.3.3 Terminal Layer Expressions

Table 5.9 lists the detailed terminal height equations used in Figure 3.4 of the flow classification scheme. The equations differ from the usual equations available in the literature through geometric factors that measure the vertical or horizontal momentum strengths and through factors measuring the direction of the buoyancy force. The first column also gives the adopted numerical values.

5.3.4 Model Coefficient Values

Any predictive model describing turbulent flow processes contains a number of constants that must be determined from experimental data. The coefficient values for flow modules, transition rules, and classification criteria of CORMIX1 are listed in Tables 5.10, 5.7, and 5.8, respectively. A large number of constants appear as required by the different physical processes in the various flow zones.

The consistent procedure used in evaluating the numerical values of the coefficients was to refer to basic experiments reported (or summarized) in the literature that deal with specific flow processes. The majority of the coefficients values have been chosen in this fashion without any adjustment. If conflicting data were reported in the literature, a mean value was adopted or seemingly dubious data were rejected. In several instances (notably for recirculation zone estimates for full vertical mixing) no reliable data, or no data at all, has been reported in the literature. Often these processes are difficult to measure and some judicious estimation was made. Subsequent system evaluation and validation (see next chapter) led to some adjustment of coefficients in that category. Ultimately, it is expected as more detailed experiments are conducted in the future that those system coefficients that currently have a limited data base can be confirmed or modified.

Furthermore, it should be noted that there is a considerable overlap among flow constants for various modules (Table 5.10), the transition rules (Table 5.7), the flow criteria (Table 5.8), and the terminal height expressions (Table 5.9). Care has been taken in setting values so that there is consistency between the various coefficient types.

Of course, the ultimate validation of the present predictive methodology together with the relevant coefficient values must come from the ability to simulate complex flow and mixing phenomena in agreement with available data. This is addressed in the following Chapter.

Table 5.9 Stratified Terminal Height Expressions

Constant Value	Equation Used in CLASS	References or Comments
CT1 = 2.1	$Z_t = (CT1 \cdot L_m^{1/3} L_b^{2/3} \sin \theta_0^{1/3}) \sin \theta_0 + (CT4 \cdot L_b^{1/9} L_b^{8/9}) \cos \theta_0$	Coefficient values adapted from List (1982) and Wong (1984)
CT2 = 2.1	$Z_t = CT2 \cdot L_m' \sin \theta_0^{1/4}$	
CT3 = 2.0	$Z_t = CT3 \cdot L_b'^4 / (L_m'^3 \cos^{3/4} \theta_0)$	
CT4 = 2.6	$Z_t = CT4 \cdot L_b^{1/9} L_b^{8/9}$	
CT5 = 2.9	$Z_t = CT5 \cdot L_b'$	

Table 5.10 Module Constants

Coefficient	Value	Data Source, Summary Reference, or Comment
T_{11}, T_{12}	2.3	A) Adapted from Wright (1977), Fischer et al. (1979), List (1982), Holley and Jirka (1986), Lee et al. (1987).
S_{11}, S_{12}	0.18	See A
B_{11}, B_{12}	0.11	See A
T_{11B}	0.07	See A
S_{13}	0.18	See A
S_{13A}	0.0058	See A
B_{13}	0.11	See A
S_{14}	0.18	See A
B_{14}	0.11	See A
T_{14B}	2.0	See A
T_{16}, T_{17}	1.6	See A
S_{16}, S_{17}	0.30	See A
B_{16}, B_{17}	0.3	See A
B_{21}	0.11	See A
T_{16B}	0.5	See A
T_{21}	1.5	See A
T_{21M1}	5.6	See A
T_{21M2}	7.5	See A
T_{22}	1.0	See A
S_{22}	0.35	See A
B_{22}	0.3	See A

Table 5.10 (Continued)

Coefficient	Value	Data Source, Summary Reference, or Comment
SB ₃₁ , SB ₃₃	1.7	Centerline/bulk dilution conversion, Holley and Jirka, (1986), Lee et al.
SB ₃₂	1.4	B) Upstream intrusion in crossflow, Jones et al. (1982), Chu and Jirka (1986)
AL _{32A}	11.4	See B
AL _{32B}	0.38	See B
CD ₃₂	1.0	See B
BH ₃₂ , BH ₃₄	2.6	See B
SR ₃₃	2.0	See B
SB ₃₄	1.3	See B
AL ₃₄	0.1	See B
CD ₃₄	2.0	See B
SB ₃₆ , SB ₃₇	1.4	Wong (1984)
HSS ₃₆	0.5	See B
CD ₃₆ , CD ₃₇	1.2	See B
CSS ₃₆	0.65	See B
AL ₃₆ , AL _{37B}	0.26	See B
BH ₃₆ , BH ₃₇	2.0	See B
HSS ₃₇	1.7	See B
AL _{37A}	0.69	See B
CD ₄₁	2.0	C) Density current spreading, Simpson (1982), Jirka and Arita (1987)
E ₄₁	0.25	See C

Table 5.10 (Continued)

Coefficient	Value	Data Source, Summary Reference, or Comment
CD ₄₂	2.0	See C
E ₄₂	0.25	See C
BV ₅₁	0.3	D) Based on data comparison for wake recirculation
XR ₅₁	5.0	See D
EZ ₆₁ , EZ ₆₂	0.2	E) Fischer et al. (1979), Holley and Jirka (1986)
EY ₆₁ , EY ₆₂	0.5	See E
EO ₆₁ , EO ₆₂	0.0015	See E

Chapter VI

System Evaluation and Verification

In this chapter the predictions of CORMIX1 will be compared with laboratory and field data. This chapter is not meant to be an exhaustive validation of all possible CORMIX1 flow classes and associated predictions, but rather a test of key CORMIX1 modules which are common to many flow protocols (flow classes) and an illustration of the flexibility of the system in handling complex environment and discharge conditions.

While CORMIX1 can accommodate many possible flow configurations, actual available laboratory or field data are quite limited. In Section 6.1 comparisons are made with data for the initial subsurface regimes (buoyant jets) of mixing processes in the absence of any boundary effects. This validation for the initial flow modules (MODs 11 through 23) is important in view of the strong initial mixing common in most (but not all) environmental discharge situations and in view of the larger body of literature concerning the behavior of unconfined buoyant jets. Section 6.2 addresses more complex flows where different forms of boundary interaction processes play a significant role.

In all of the comparisons shown below the numerical constants and coefficients values have been consistently set to the values summarized in Chapter V.

To facilitate comparison with the non-dimensionalization that is frequently used in the available literature the following parameters are introduced:

Densimetric Froude Number

$$F_0 = u_0 / (g_0' D)^{1/2} = (\pi/4)^{1/4} L_m / L_0 \quad (6.1)$$

Jet/Crossflow Ratio

$$R = u_0 / u_s = L_m / L_0 \quad (6.2)$$

Stratification Parameter

$$T = \Delta\rho_0 / [D(-d\rho_s/dz)] = L_m'^4 / (L_m^2 L_0^2) \quad (6.3)$$

6.1 Buoyant Jets in Unconfined Ambient

6.1.1 Comparison With Experimental Data

The following sections will present analyses of near-field flows, starting with buoyant jets in a stagnant uniform ambient, followed by neutrally, positively, and negatively buoyant jets in uniform crossflows, and finally flows in a stratified stagnant ambient. To validate these buoyant jet near-field flows, CORMIX1 predictions are compared with laboratory data from Anwar (1972), Cederwall (1963) Fan (1967), Jordinson (1956), Wright (1977), Margason (1968), and Anderson et al. (1973).

6.1.1.1 Stagnant Ambient

Figure 6.1 shows two cases of Fan's (1967) trajectory data for a buoyant jet in a stagnant uniform ambient compared with CORMIX1 projections. Fan released a dyed buoyant jet horizontally ($\theta_0 = 0^\circ$) into a uniform ambient density tank. Photographs recorded visual plume outlines. For this stagnant environment (for which both L_m and L_b tend to infinity) CORMIX1 classifies the flow as H4-0 (see section 5.1.1), since for finite depth H (equal to the laboratory tank depth) some boundary interaction will inevitably occur. However, Fan does not report any detail on these interaction processes.

Figure 6.1a shows Fan's buoyant jet with relatively strong horizontal momentum flux ($F_0 = 66$). The flow travels horizontally at first, after some distance the buoyancy force deflects the flow vertically. For this stagnant condition the predicted trajectory is in excellent agreement with the observed plume outline. As noted in Section 5.2.1.1, CORMIX1 predicts a plume half-width b that corresponds to a local concentration of $1/e = 37\%$ of the centerline concentration. Assuming a 10% width for the photographically recorded plume boundary (as traced by Fan) these values may be expected to be wider by a factor of about 1.5. This interpretation appears in good qualitative agreement with the predictions.

In contrast, Figure 6.1b shows a horizontal buoyant jet with relatively weaker momentum ($F_0 = 10$). In this case the horizontal intrusion of the jet is small, and the flow exhibits a strong vertical deflection, which appears to be slightly under-predicted by CORMIX1.

CORMIX1 results for horizontal buoyant jets in stagnant ambients with a wide range of Froude numbers appear in Figure 6.2 in comparison with three different experimental data sources. This figure seems to illustrate two facts:

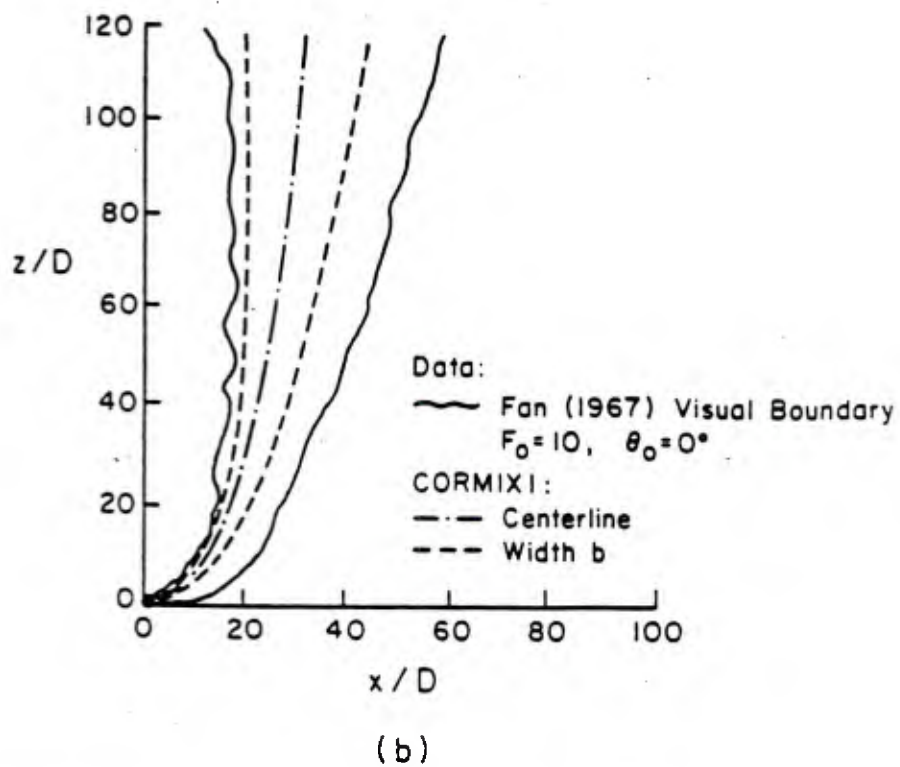
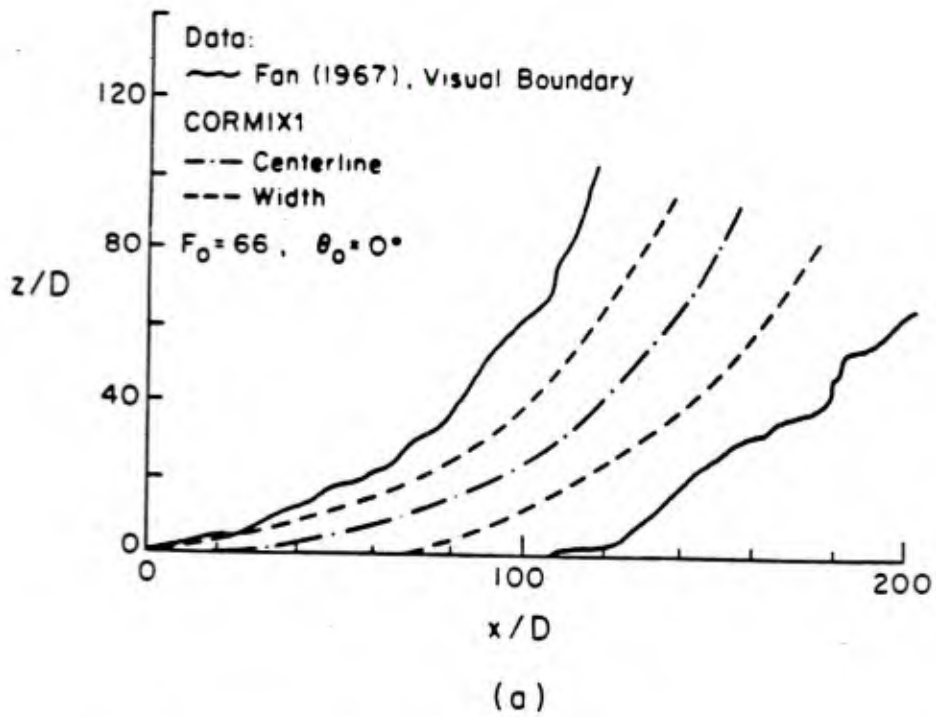

Figure 6.1 Horizontal Buoyant Jet Trajectory in Stagnant Ambient. a) Weak jet, b) strong jet.

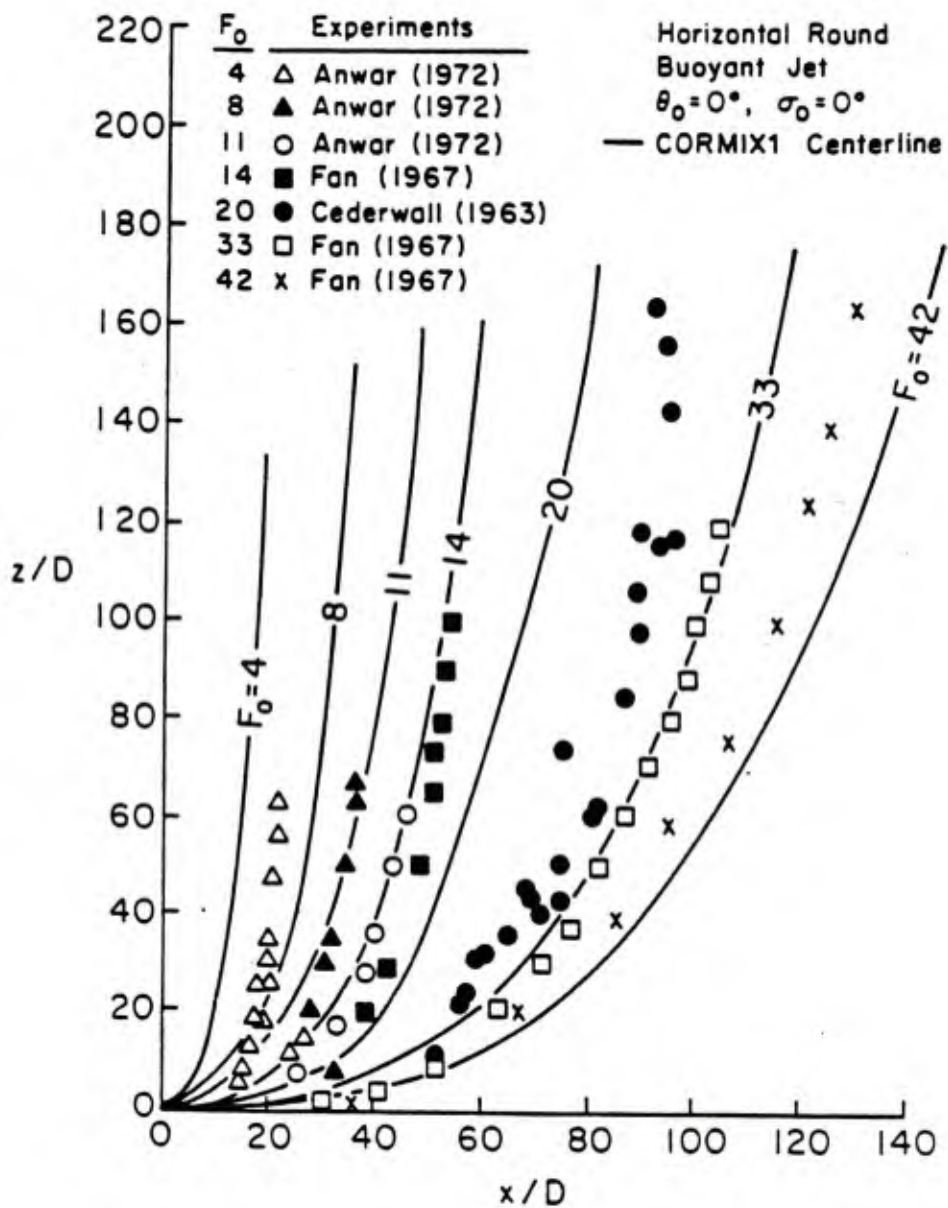

Figure 6.2 Horizontal Buoyant Jet Trajectories in Stagnant Ambient Over a Range of Froude Numbers

i) the agreement of CORMIX1 with the observed trajectories is good, within $\pm 20\%$ for the horizontal penetration, and
ii) the disagreement among different experimental data source is at least as large. This can be seen indirectly using CORMIX1 as the standard since in some cases an over-prediction and in others an under-prediction is apparent. Such discrepancies, or levels of accuracy, are typical in predictions and/or experiments with turbulent flows, and may be related to the experimental setup, some unsteadiness, the exact method of determining centerline position, and other factors. In summary, Figure 6.2 shows that overall CORMIX1 predictions are quite good, and well within the normal scatter evident from the experimental results.

It should be noted that all the buoyant jet trajectories displayed in Figure 6.2 could have been collapsed into a single curve (at least for sufficiently large F_0) if the appropriated length scale L_w was used in normalization instead of D . This was avoided in order to better display the jet behavior and data scatter. The appropriate normalization has been used in Figure 6.3 in which centerline dilution data from three experimental sources covering a wide range of F_0 is displayed in a compact fashion (Note that $DF_0 = [(4/\pi)^{1/4} L_w]$). The agreement is satisfactory in the entire jet/plume transition range.

6.1.1.2 Flowing Unstratified Ambient

6.1.1.2.1 Pure Jets In Crossflow

Figure 6.4 shows the centerline trajectory from an experiment of Jordinson (1956) for a pure jet ($F_0 = \infty$) discharging vertically in a crossflow with velocity ratio $R = 6.2$ ($R = u_0/u_s$). Here, the CORMIX1 predictions (flow class V2) show slightly more jet deflection than the experimental data near the orifice, and slightly less after the flow becomes strongly deflected.

Again, such disagreement has to be interpreted in the light of the experimental methods employed. The centerline used by Jordinson was defined as the maximum velocity point which for a cross-flow deflected jet (especially in the weakly deflected stage) is always considerably upstream of the point half-way between the upstream and the downstream jet boundary. This factor, related to the horse-shoe like concentration distribution in the cross-section of such jets, is also addressed by Fan (1967), Rajaratnam (1976), and Jirka and Fong (1981).

Two other examples of jet trajectories in a crossflow are given in Figure 6.5 in comparison to Margason's (1968) data. Figure 6.5a illustrates a slightly co-flowing discharge ($\theta_0 = 60^\circ$, $\sigma_0 = 0^\circ$) for two crossflow ratios (R

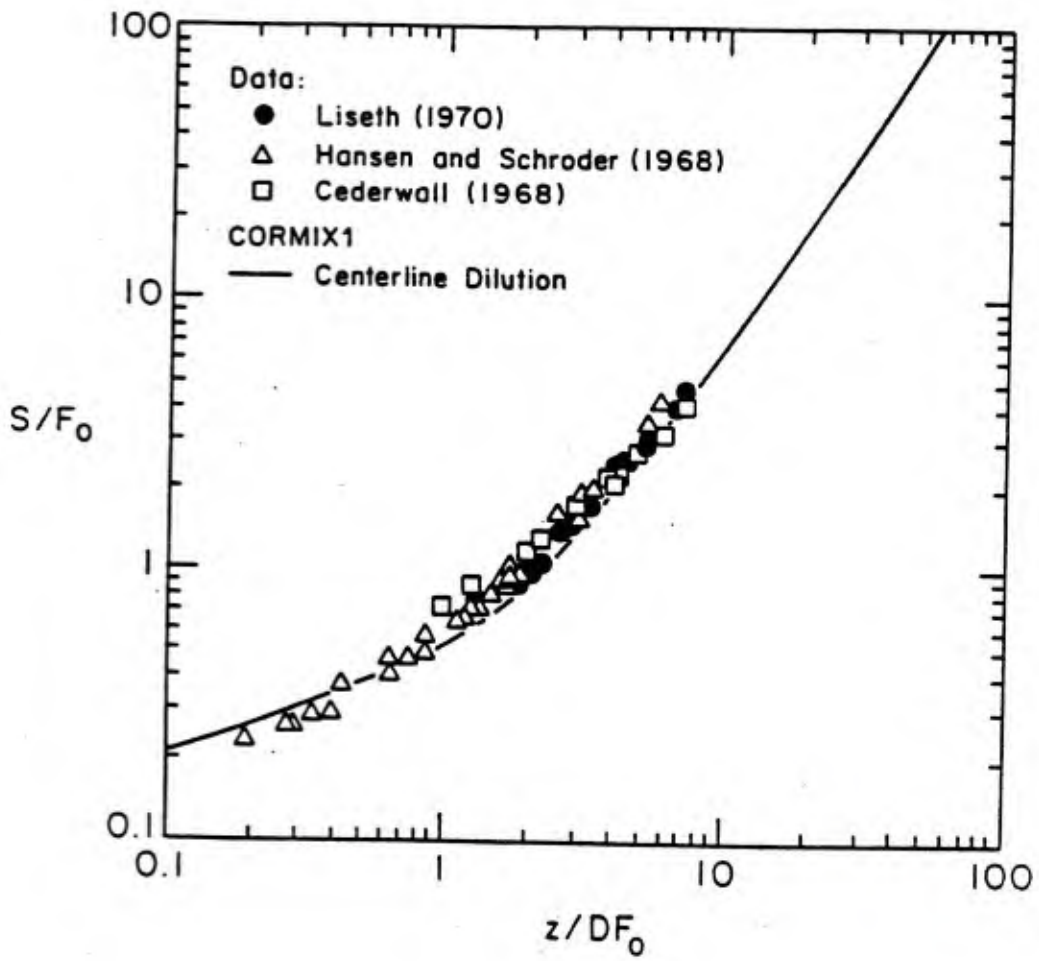

Figure 6.3 Horizontal Buoyant Jet Dilution in Stagnant Ambient

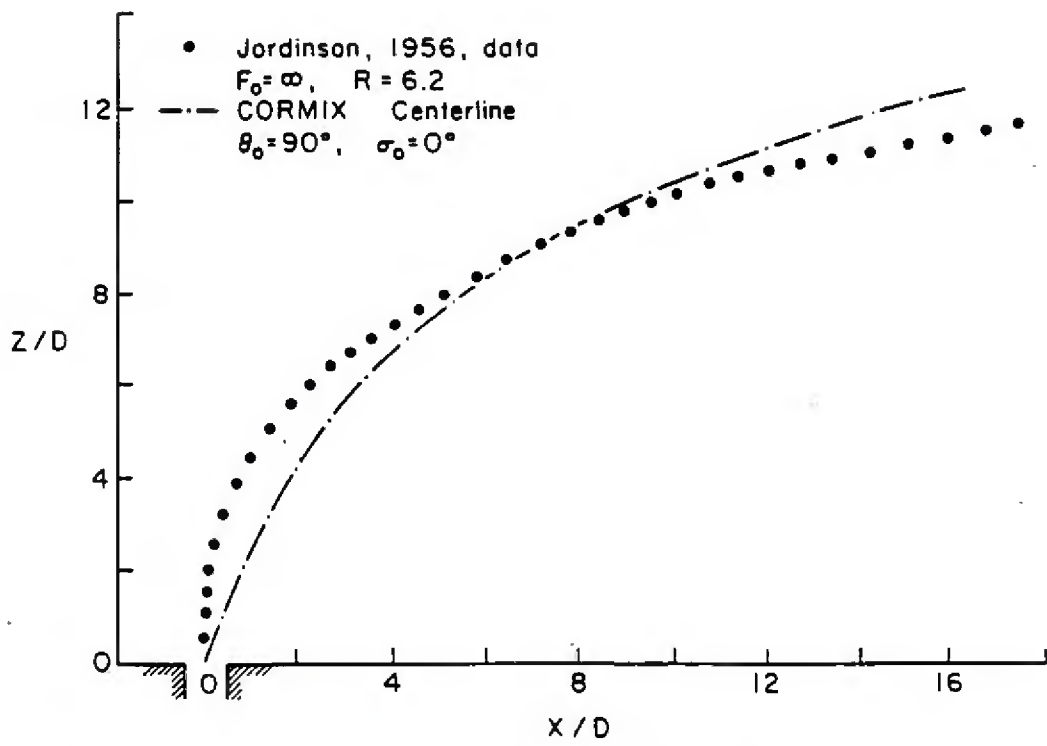

Figure 6.4 Non-buoyant Jet Trajectory in Uniform Crossflow

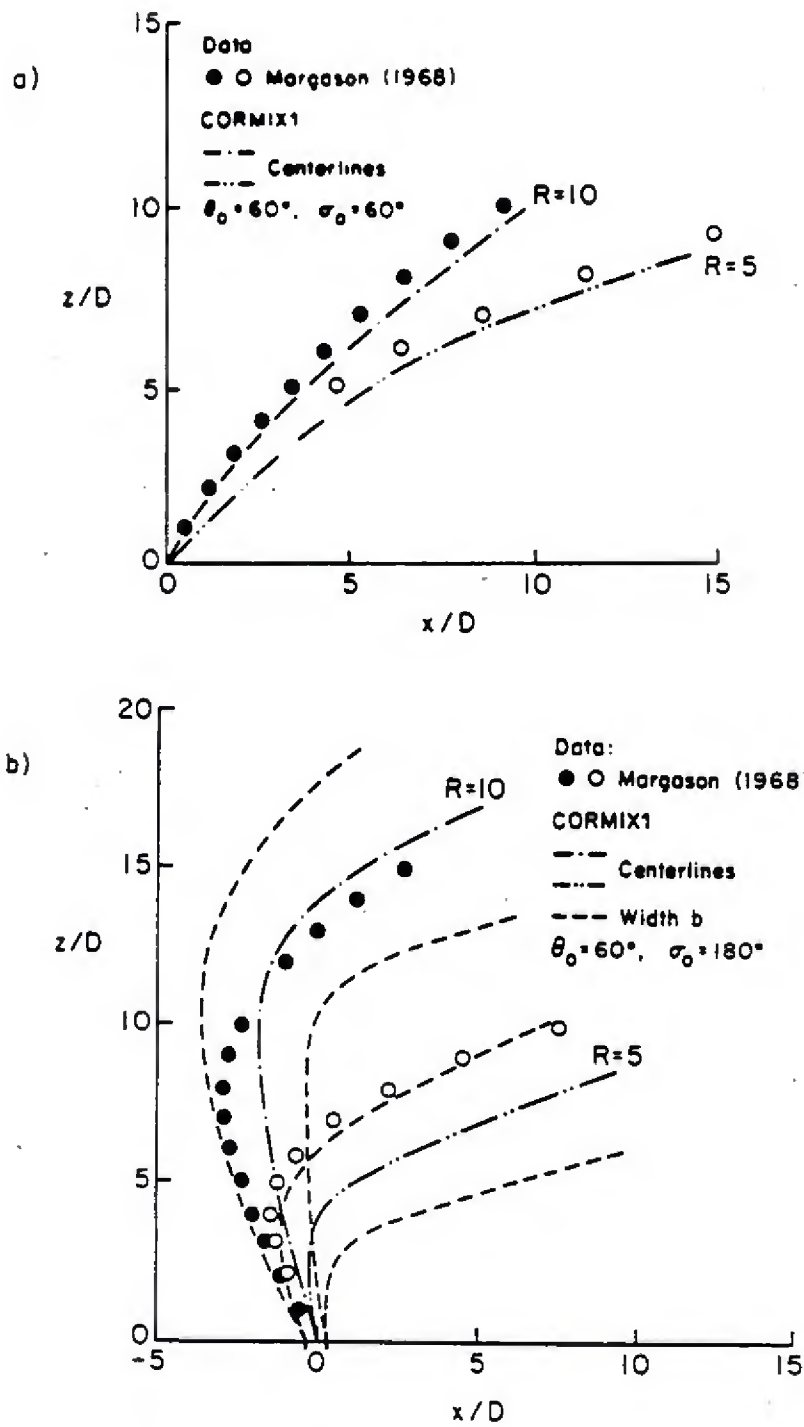

Figure 6.5 Non-Buoyant Jets at Various Discharge Angles in Uniform Crossflow

= 5 and $R = 10$). Excellent agreement can be seen. The more severe test of a slightly counter-flowing discharge ($\theta_0 = 60^\circ$, $\sigma_0 = 180^\circ$) is shown in Figure 6.5b for the same crossflow ratios. For the strong crossflow case, $R = 5$, the predicted jet trajectory is somewhat more deflected than the observed one.

6.1.1.2.2 Buoyant Jets in Crossflow

The effect of adding buoyancy to the jet flow will now be considered. Figures 6.6 and 6.7 present Fan's trajectory, dilution, and width data for a vertically discharging buoyant jet, $\theta_0 = 90^\circ$, in crossflow. Figure 6.6 shows Fan's experiment with $F_0 = 20$ and $R = 12$. CORMIX1 (flow class V1, mdnf, mdff, bdff) predictions are in good agreement with trajectory, dilution, and width data. Figure 6.7 shows a jet with similar buoyancy ($F_0 = 20$) but with a considerably stronger cross-flow ($R = 4$), causing the flow to deflect more strongly. Excellent agreement is apparent.

Figure 6.8 shows a CORMIX1 trajectory prediction (flow class V1 mdnf, mdff, bdff) for a laboratory experiment by Wright (1977). Figure 6.8 employs a logarithmic scale (as used by Wright) to show the trajectory data for a vertical buoyant jet ($R = 37$ and $F_0 = 67$) into a crossflow. The logarithmic scale display exhibits the different trajectories laws (slopes in Figure 6.8, equivalent to the exponents of the power laws) that are used in CORMIX1. As opposed to Fan's data, CORMIX1 shows for this case a slight over-prediction (factor of 1.5) in the predicted vertical rise of the flow.

6.1.1.2.3 Negatively Buoyant Jets in Crossflow

Figure 6.9 shows the results of an experiment by Anderson et al. (1973) for a negatively buoyant jet into a slightly co-flowing crossflow ($\theta_0 = 60^\circ$, $\sigma_0 = 0^\circ$, $F_0 = 11.0$, and $R = 5.5$). In this case CORMIX1 predicts an NV1 flow class (mdnf, mdff, bdff) with numerical results that are in good agreement with trajectory, dilution, and width data. In particular, note that CORMIX1 predicts the flow trajectory decreasing in elevation in the bdff as is typical for negatively buoyant flows.

6.1.1.2.4 Buoyant Jets with Three-Dimensional Trajectories

Figure 6.10 presents Ayoub's (1971) buoyant jet experiment with a transverse horizontal discharge in a weak crossflow ($F_0 = 15$, $R = 15$, $\theta_0 = 0^\circ$, $\sigma = 90^\circ$). The

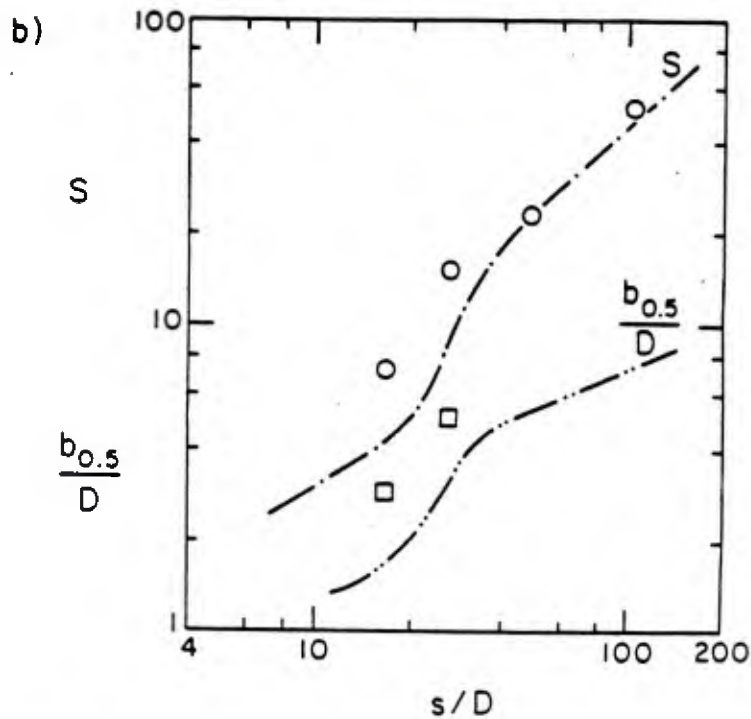
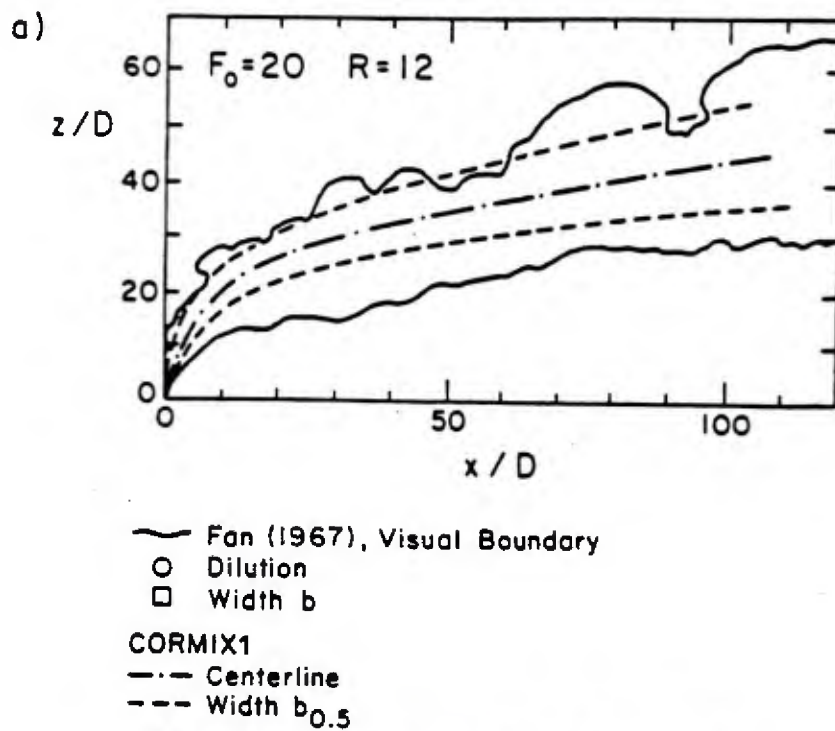

Figure 6.6 Buoyant Jet Discharging Vertically into Weak Crossflow. a) Trajectory, b) width and dilution.

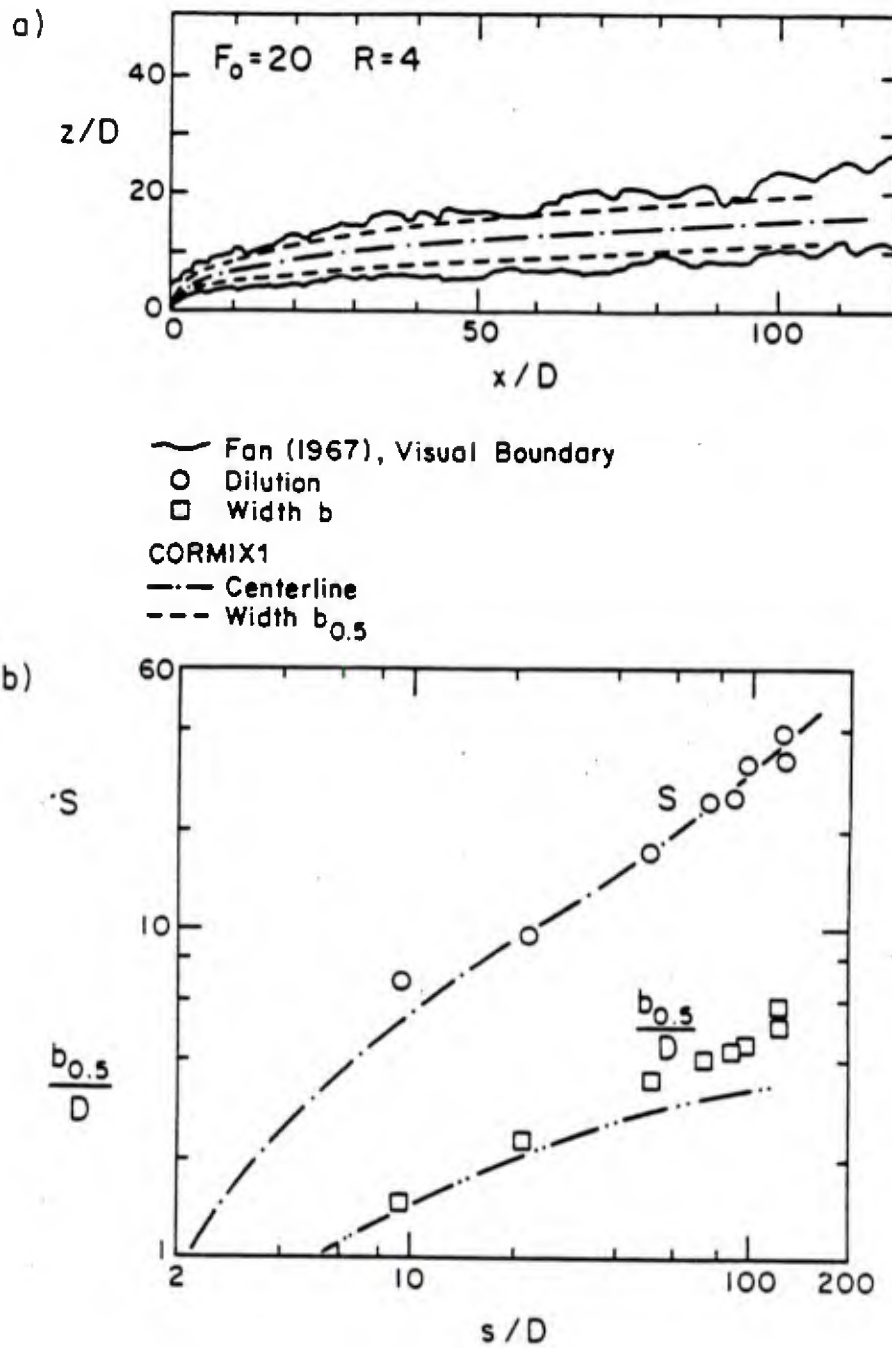

Figure 6.7 Buoyant Jet Discharging Vertically into Strong Crossflow. a) Trajectory, b) width and dilution.

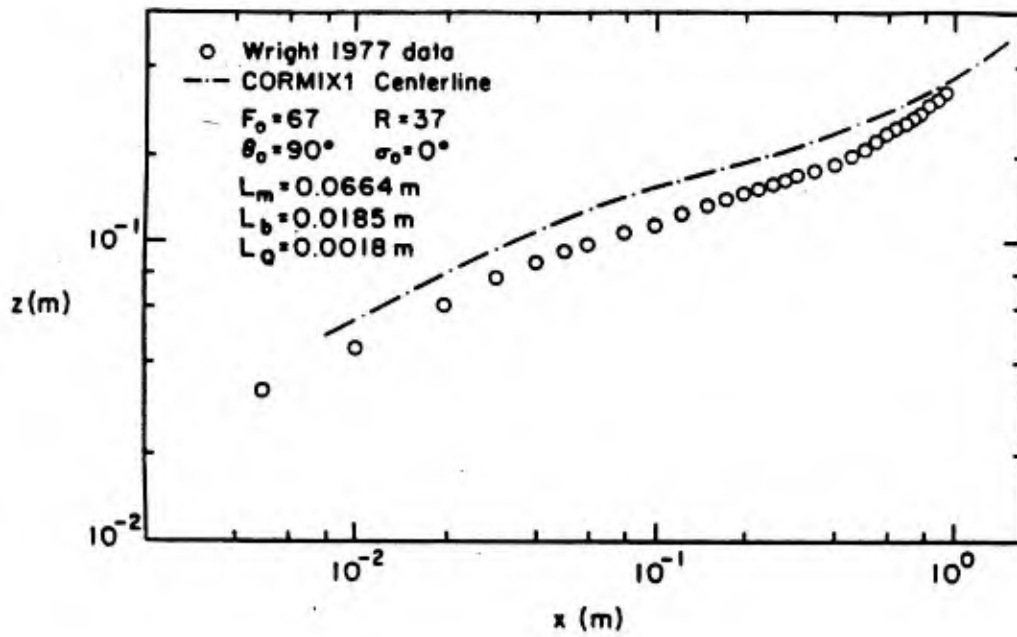

Figure 6.8 Buoyant Jet Discharged Vertically into Weak Crossflow (Logarithmic presentation)

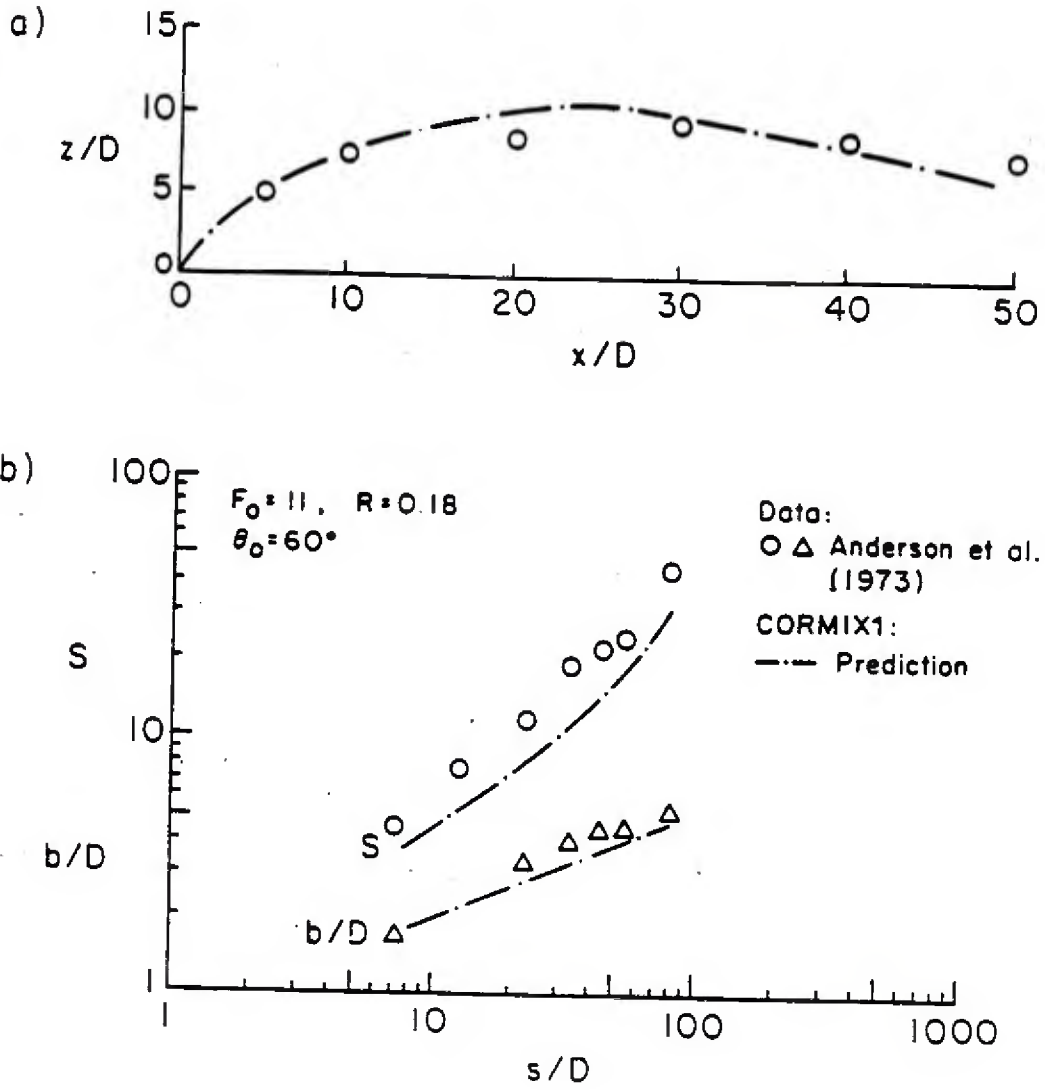

Figure 6.9 Negatively Buoyant Jet Discharging Obliquely Upward in Uniform Crossflow. a) Trajectory, b) dilution and width.

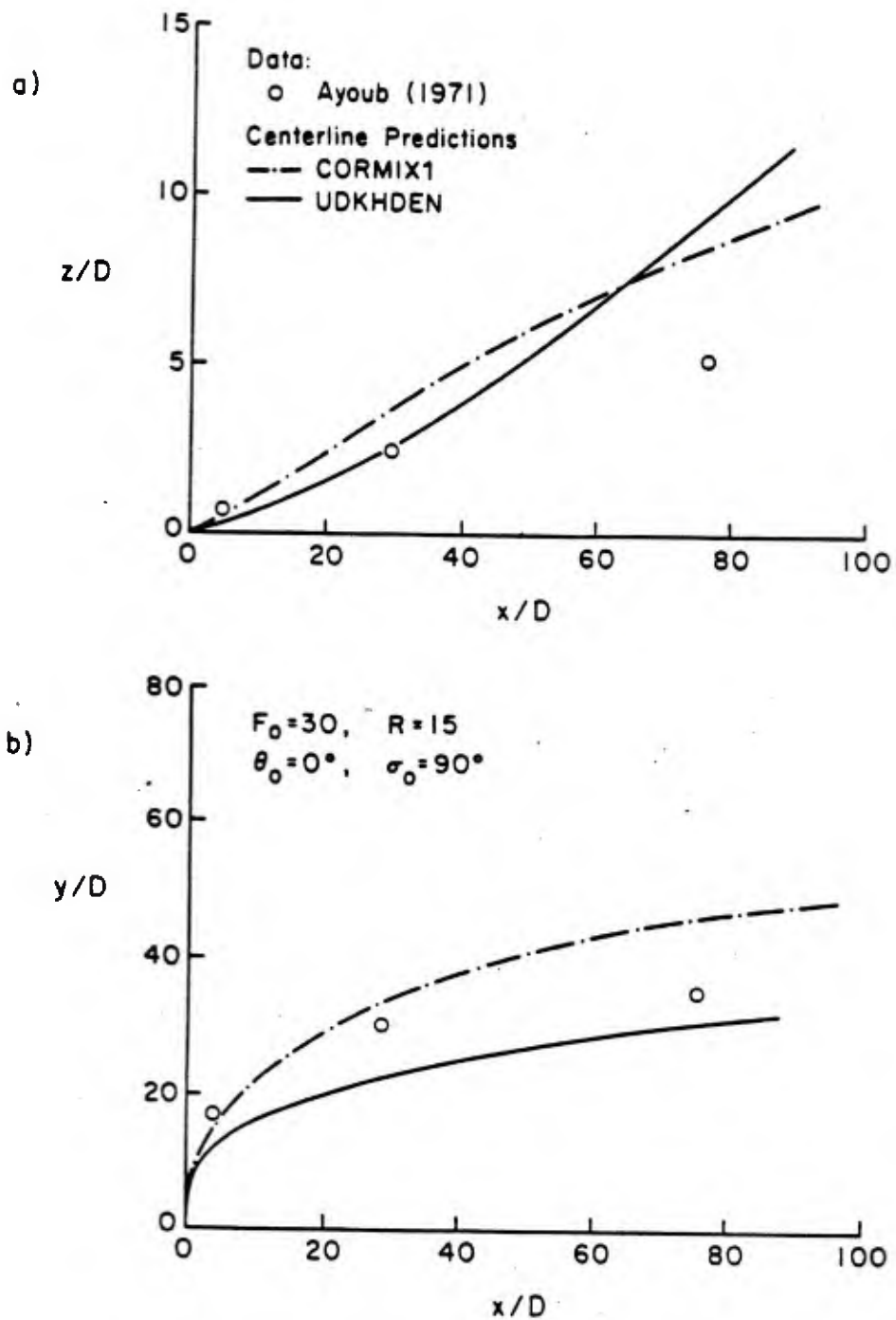

Figure 6.10 Three-Dimensional Trajectory of Transverse Horizontal Buoyant Jet in Weak Crossflow. a) Side view, b) plan view.

experimental trajectory results are compared to CORMIX1 predictions as well as to the jet integral model UDKHDEN (see Muellenhoff, et al. 1985). CORMIX1 predicts an H1 flow class (mdnf, mdff, bdf) for this discharge. The observed transverse penetration (Figure 6.10b) is reasonably well predicted by both models. The vertical rise, solely due to buoyancy effects, however, is under-predicted by both models (Figure 6.10a). Unfortunately no detailed data or photographs are available for Ayoub's data, but it is suspected that this flow may be influenced by flume boundary (shallowness) effects.

Much better agreement, with both predictive models, is obtained for a case of stronger crossflow (or alternately, for the same crossflow, a weaker buoyant jet so that the shallowness will have less influence). This is shown in Figure 6.11 for the conditions $F_0 = 15$ and $R = 5$.

6.1.1.3 Buoyant Jet in Stratified Stagnant Ambient

The effect of ambient density stratification on buoyant jets is illustrated in Figure 6.12. Figure 6.12a shows the plume boundary for Fan's buoyant jet experiment for a linearly stratified stagnant ambient. This plot represents a horizontal discharge ($\theta_0 = 0^\circ$, $\sigma_0 = 0^\circ$) with a Froude number $F_0 = 26$ and stratification parameter $T = 1200$. CORMIX1 predicts a plume-like flow class S5 (mdnf, bdnf). Trajectory data, including the terminal level, $z_t/D = 76$, agree well with Fan's visual results.

In the absence of any specified ambient crossflow CORMIX1 does not predict any properties of the buoyant spreading regime except the thickness of the terminal layer of $b_v/D = 38$ which is in good agreement with the visual data. As discussed in Section 2.2 this process is strongly influenced by the crossflow strength and for stagnant conditions no steady-state solution is possible. Hence, the layer thickness (shown on the left and right margins of Figure 6.12a) are not comparable to any steady-state model predictions. CORMIX1 however provides some results of the near-field "boil" produced by the vertically rising plume, such as the maximum "boil" elevation of $z_m/D = 116$ (see Fig. 6.12a) which is slightly greater than the visual plume outline.

The effect of ambient density stratification ($T = 1200$) on a stronger jet ($F_0 = 51$) discharging near-vertically ($\theta_0 = 45^\circ$, $\sigma_0 = 0^\circ$) is shown in Figure 6.12b. CORMIX1 predicts a jet-like flow class S3 (mdnf, mdls-v) and its trajectory data agree well with Fan's results. The predicted terminal level, $z_t/D \approx 48$, the maximum elevation of rise $z_m/D = 43$, and the width $b_v/D = 44$ at the terminal level are all in

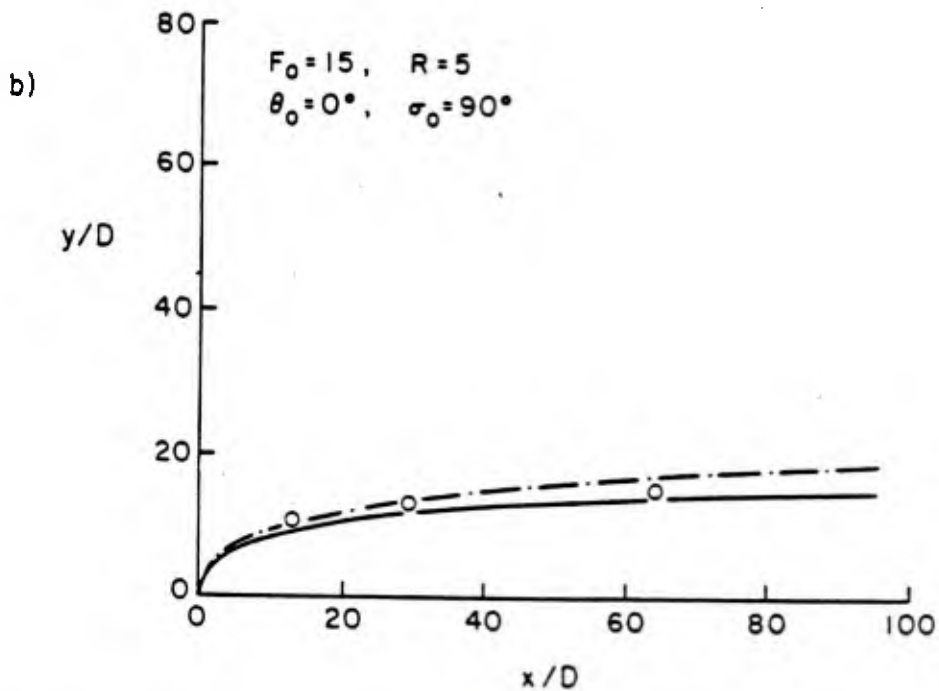
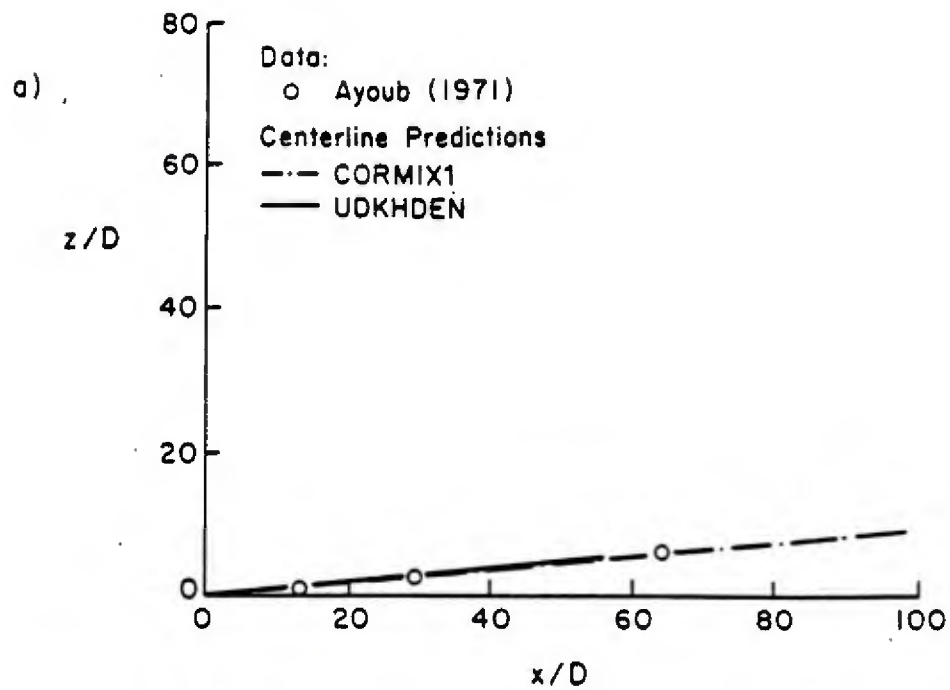
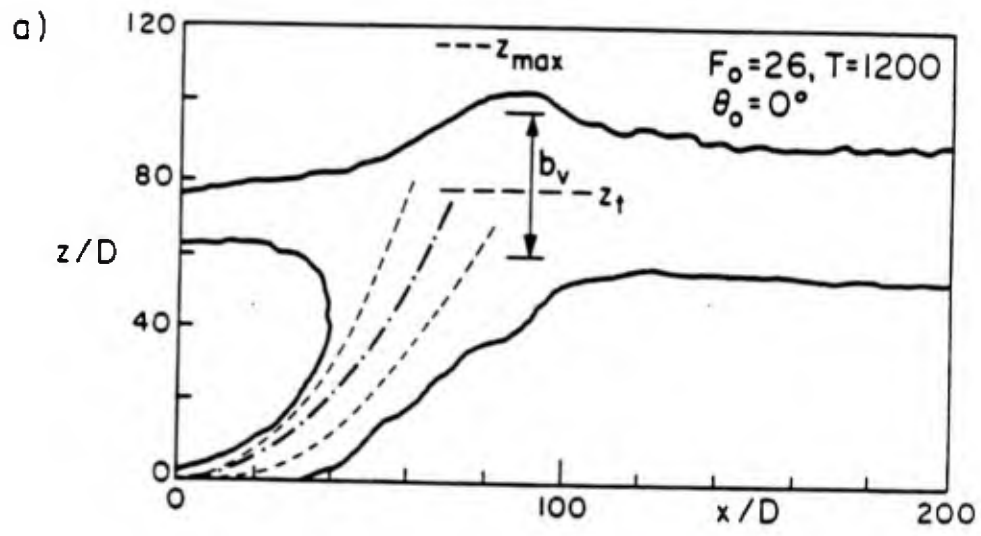

Figure 6.11 Three-Dimensional Trajectory of Transverse Horizontal Buoyant Jet in Strong Crossflow.
 a) Side view, b) plan view.



— Fan, 1967, Visual Boundary
 - - - CORMIX1 Centerline
 ···· Width b

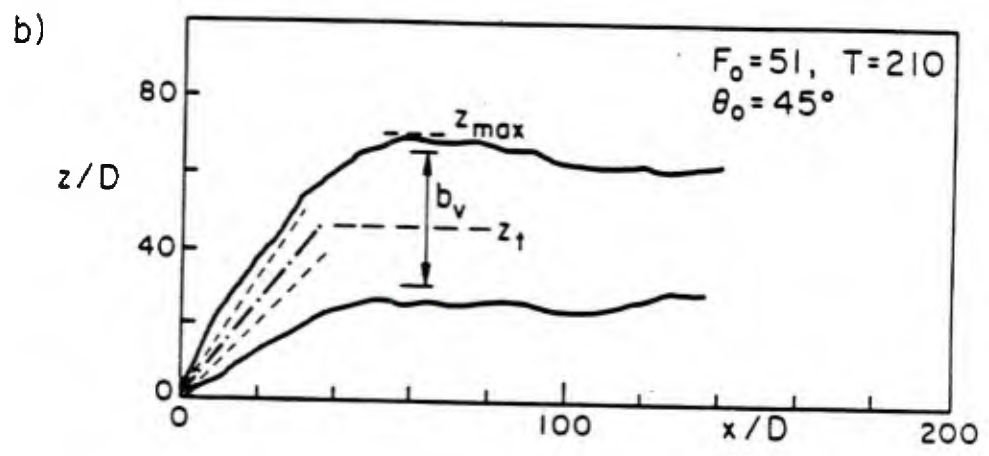

Figure 6.12 Buoyant Jet Trajectory in Stratified Stagnant Ambient. a) Horizontal discharge, b) oblique discharge.

agreement with Fan's visual results.

6.1.2 Comparison of Predictions With Jet Integral Models

Because experimental data on buoyant jets is limited, this section presents CORMIX1 predictions in comparison with some common jet integral models. Several such model formulations exist and have been extensively tested against various data sources (Muellenhoff et al. 1985, Wong, 1984). Of course, such integral models are limited to buoyant jet flows in unconfined ambients and cannot address any boundary interaction.

6.1.2.1 Buoyant Jet in Uniform Crossflow

Figure 6.13 presents a comparison of CORMIX1 with the integral jet models by Jirka and Fong (1981) and UDKHDEN (Muellenhoff, 1985). Model predictions for trajectory (Figure 6.13a) and dilution (Figure 6.13b) are given for a buoyant jet ($F_0 = 10$) in a crossflow ($R = 10$) with $\theta_0 = 90^\circ$ and $\sigma_0 = 0^\circ$. The trajectory relationships for the three models appear to be in general agreement, with CORMIX1 and UDKHDEN predicting a stronger bending by the crossflow than the model of Jirka and Fong. CORMIX1 predicts the most conservative dilution values of the three models as shown in Figure 6.13b. It should be noted that the bulk dilution values from UDKHDEN were adjusted by dividing by 1.7 to represent centerline dilution as shown for the other two models.

Another comparison with the jet model UDKHDEN already has been included in Figures 6.10 and 6.11 as discussed earlier.

6.1.2.2 Buoyant Jet in Stratified Crossflow

Figure 6.14 illustrates the effect of a stratified crossflow on buoyant jet behavior for the three previously discussed models. No fully documented experiments are reported in the literature for this flow configuration. Figure 6.14 represents the effect of a strong crossflow ($R = 3.0$) with a mild density stratification ($T = 1000$) on a weakly buoyant jet ($F_0 = 40$). CORMIX1 predicts a crossflow dominated flow class S1 (mdnf, mdff) with a terminal height of $z_t/D = 30$ which is obtained at a downstream distance $x/D = 1210$ as seen in Figure 6.14a. In this case, the trajectory and stratified terminal height of CORMIX1 are in good agreement with the integral models, with CORMIX1 predicting the highest terminal level and the model of Jirka

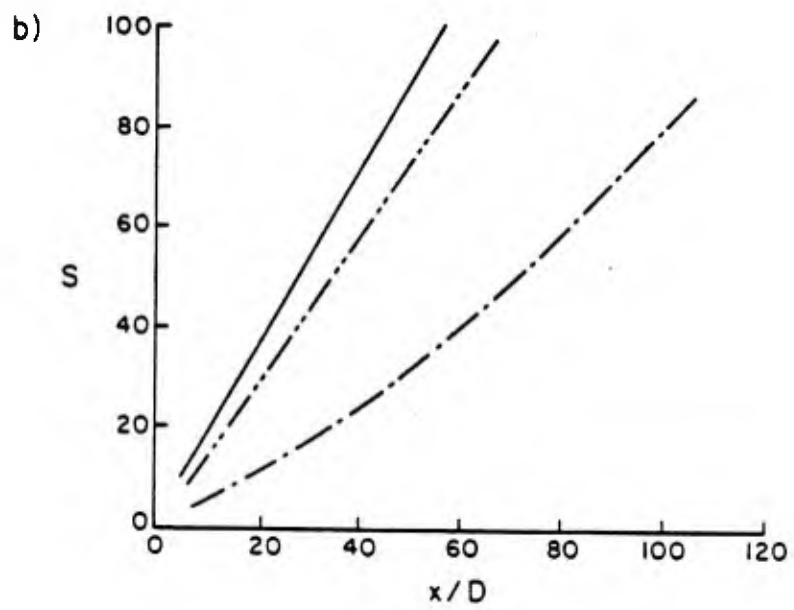
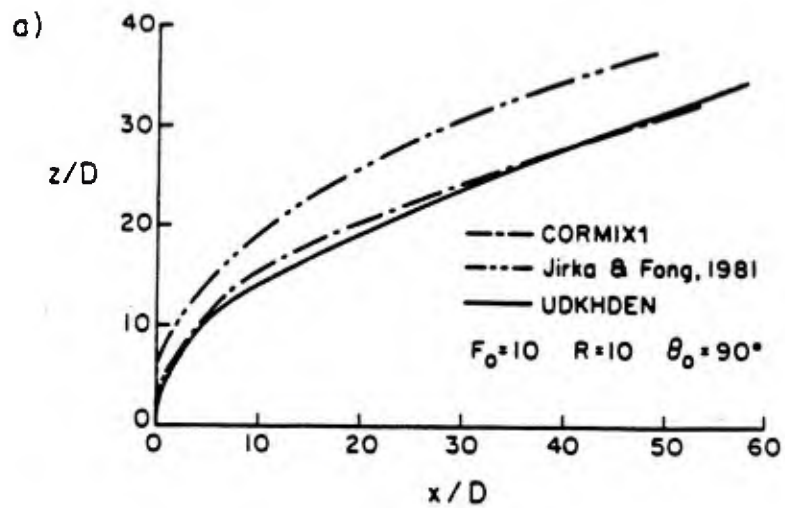

Figure 6.13 Comparison of CORMIX1 Predictions with Integral Buoyant Jet Models in Uniform Crossflow

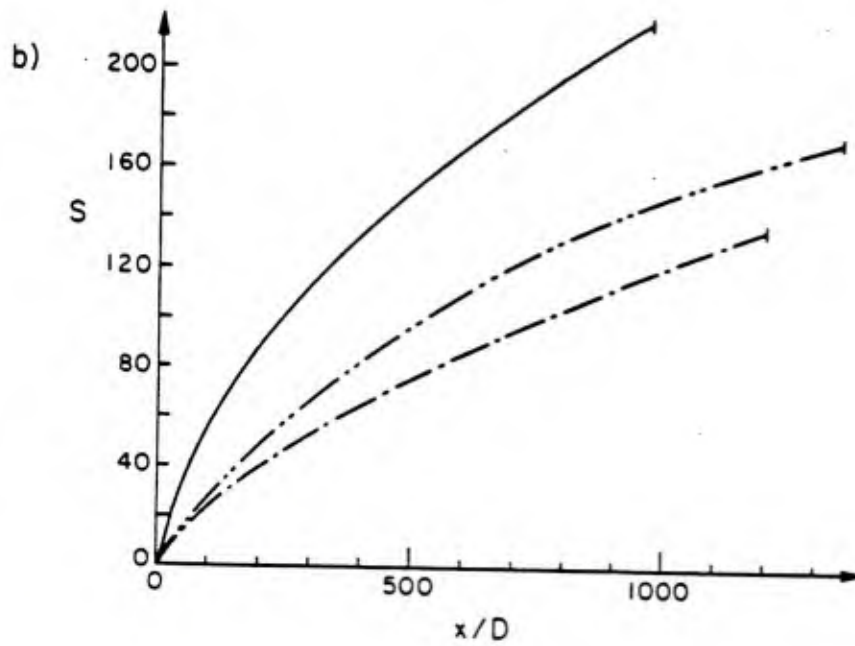
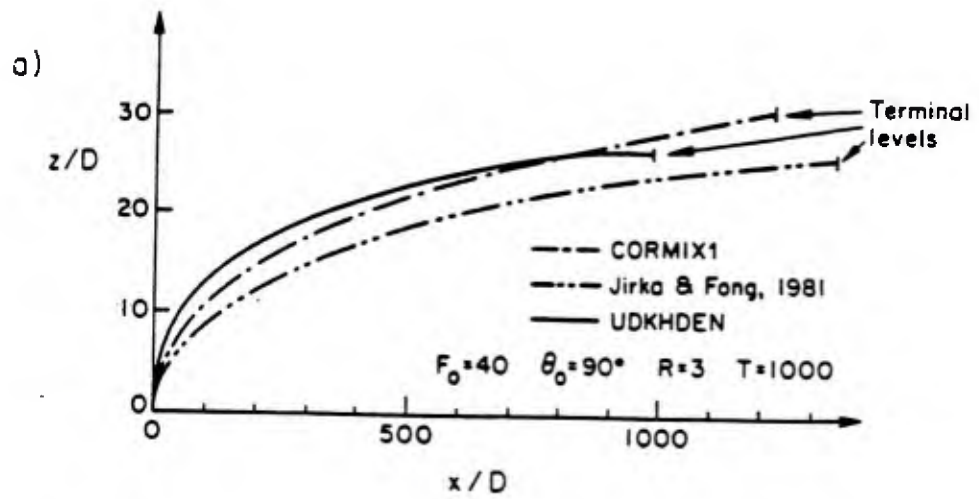

Figure 6.14 Comparison of CORMIX1 Predictions with Integral Buoyant Jet Models in Stratified Crossflow

and Fong the lowest, $z_i/D = 26$ at $x/D = 1350$. Figure 6.14b shows again that CORMIX1 predicts the most conservative centerline dilutions, with a difference of about 50% among the three models.

6.2 Complex Flows With Boundary Interaction

This section is intended to illustrate the ability of CORMIX1 to correctly classify and predict flow dynamics in the presence of various boundary interaction processes.

6.2.1 Jet Flows in Shallow Receiving Waters

Figure 6.15 presents the laboratory data of Abdelwahed and Chu (1978) for vertical discharges into shallow uniform crossflow. Figure 6.15a and 6.15b show a pure jet ($F_0 = \infty$) in weak crossflow ($R = 12$, Test 2001) and strong crossflow ($R = 6$, Test 2004), respectively. CORMIX1 predicts a flow class V2 (mdnf, mdff, surface approach, passive mixing) for both cases where the subsurface regions are limited and the surface passive mixing occurs shortly downstream of the discharge. Passive surface plume dimensions are in good agreement with visual plume outlines for both of these nonbuoyant cases. Figure 6.15c illustrates the additional influence of buoyant surface spreading for a buoyant discharge in strong crossflow ($F_0 = 12$, $R = 6$). CORMIX1 predicts a flow class V2 but with a buoyant spreading region before passive mixing occurs. Again the plume prediction agrees well with the visual surface plume boundary. This documents the importance of including both far-field processes, namely buoyant spreading and passive diffusion, in a predictive methodology.

6.2.2 Strongly Buoyant Jets in Shallow Receiving Waters

Fischer et al. (1979) present field data for the San Onofre nuclear power plant. The San Onofre Unit 1 discharge is a thermal discharge from a 4.3 m diameter outfall located 5.5 m below the surface in 9.6 m deep water off the California coast. The temperature difference between the ambient current and the discharge is 11.1°C giving rise to a buoyant acceleration of $g'_0 = 0.032 \text{ m}^2/\text{s}$. CORMIX1 predicts a flow class of V5, which represents an stable discharge with buoyant upstream intrusion and subsequent buoyant surface spreading as the plume travels downstream.

Figure 6.16a shows the CORMIX1 results compared with actual field results obtained from a tracing of an infrared picture of the actual plume. Two different crossflow velocities were used to account for possible variation in

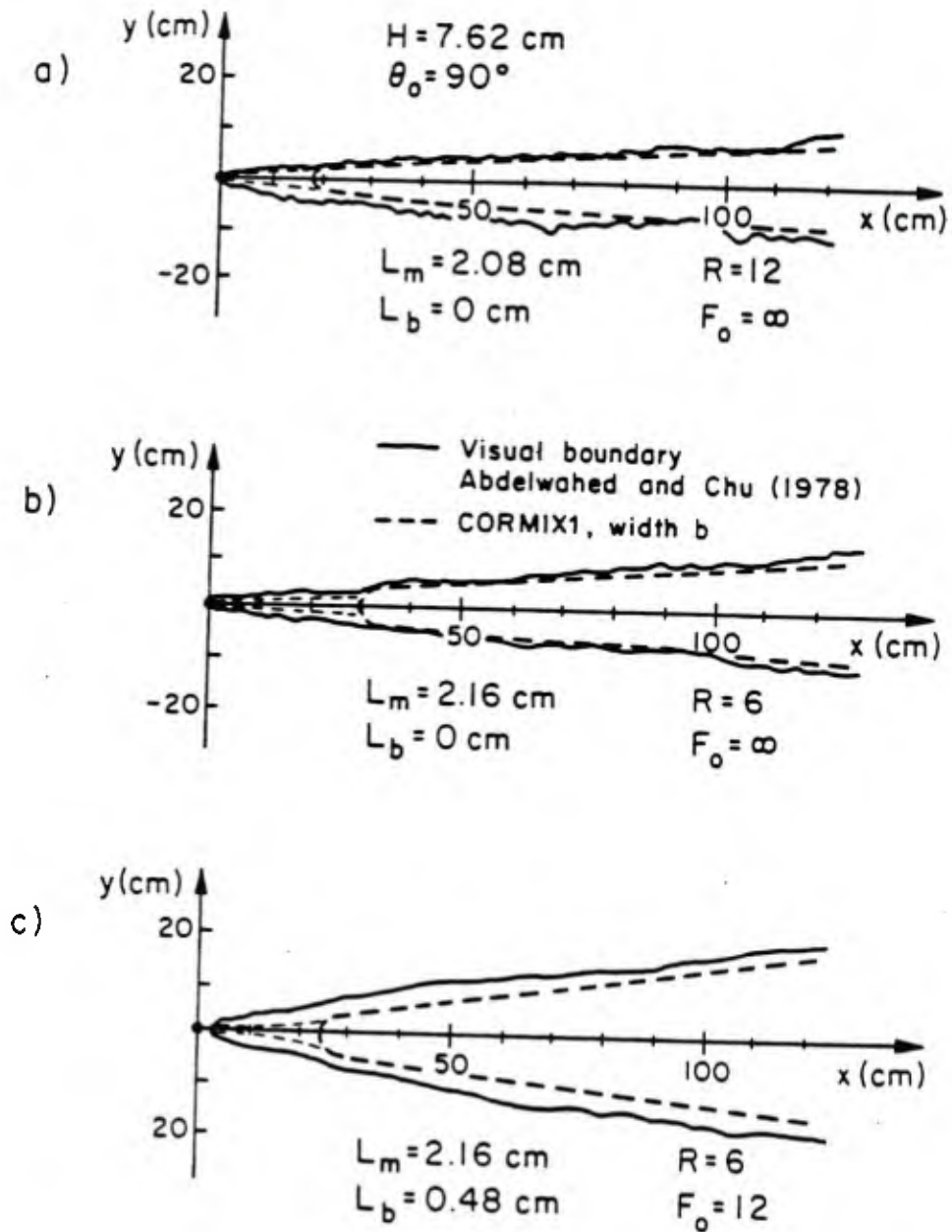

Figure 6.15 Vertical Jet Discharge into Shallow Crossflow. Plan view of plumes at water surface.

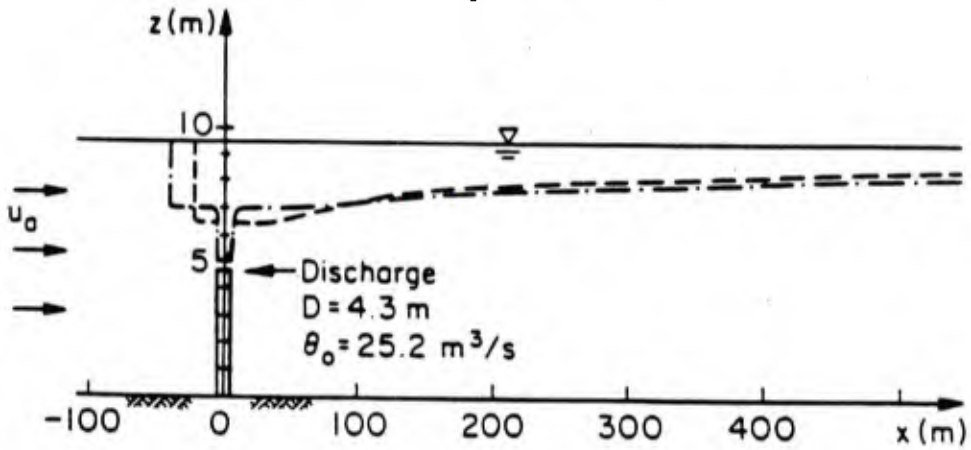
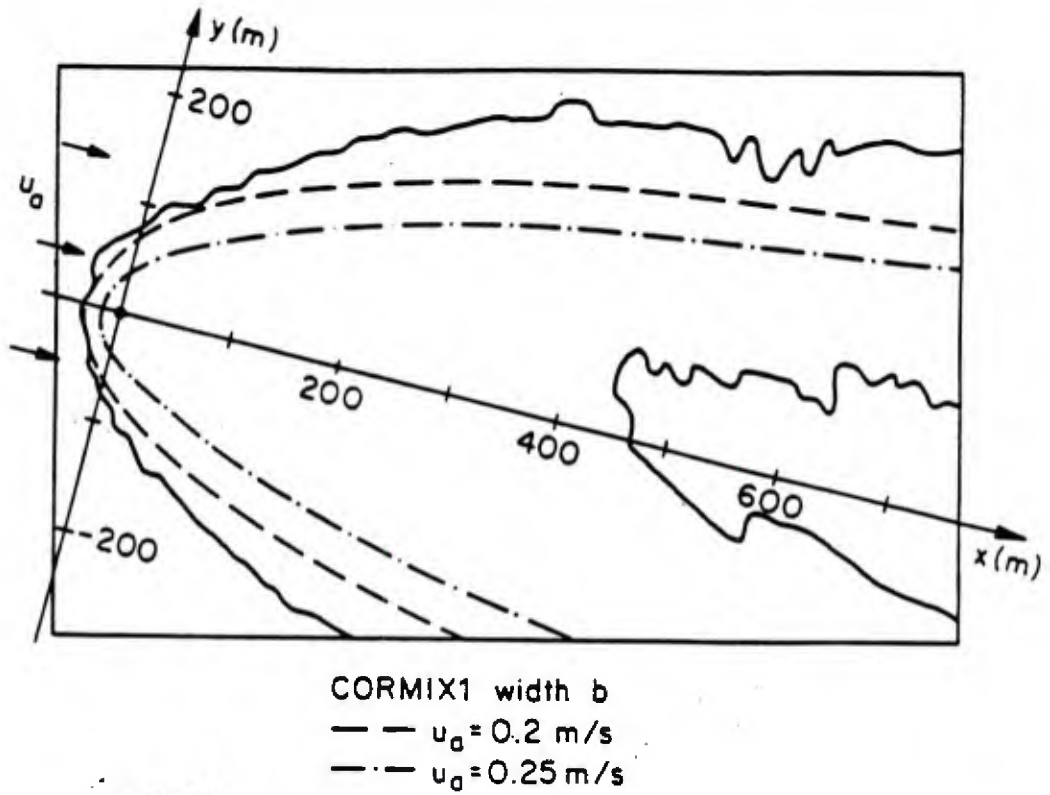

Figure 6.16 Cooling Water Outfall from San Onofre Nuclear Power Plant (Unit 1). a) Comparison of CORMIX1 prediction for surface plume, b) predicted subsurface flow pattern (side view).

the ambient data and to illustrate the sensitivity of the model. For a crossflow velocity of 0.2 m/s CORMIX1 predicts a buoyant upstream intrusion of 42 m with a flow half-width of 110 m at surface impingement. Using the slightly higher crossflow velocity of 0.25 m/s, as reported by Fischer et. al., CORMIX1 predicts a smaller buoyant upstream intrusion of 22 m with a flow half-width of 56 m at surface impingement. The field data indicate an upstream intrusion and half-width at surface impingement of about 30 m and 85 m, respectively. Overall CORMIX1 agrees well with the photographic surface data.

No field data are available for the sub-surface flow region as well as for the induced temperature field. Figure 6.16b illustrates model predictions from CORMIX1 for the discharge cross-section for the two ambient velocities. The upstream intrusion and gradual thinning in the downstream direction due to buoyant spreading is demonstrated and is consistent with the information from the plan view photograph.

6.2.3 Flows with Wake Interaction

A discharge operating in a strong crossflow can cause wake attachment. CORMIX1 was applied to data for cooling tower experiments from Viollet (1979); as reported by EPRI (1981) and illustrated in Figure 6.17. Dilution data are also included in Figure 6.17, as indicated by concentration isolines. Figure 6.17a represents an unattached flow with a strong buoyancy ($F_0 = 0.8$) and weak crossflow ($R = 2.0$). CORMIX1 predicts an unattached flow class V1. The experimental data show slightly stronger deflection than is indicated by the CORMIX1 prediction. The concentration decay c_c/c_0 along the centerline of the CORMIX1 predictions (indicated by arrows) is in excellent agreement with the experimental contour values c/c_0 .

The effect of a much stronger crossflow is illustrated in Figure 6.17b with $F_0 = 0.8$ and $R = 0.33$. Here CORMIX1 predicts an attached flow class VIa1 (wake recirculation). This is in agreement to the attachment of the experimental cooling tower plume indicated in Figure 6.17b. CORMIX1 also predicts the plume will contain enough buoyancy to subsequently lift-off from the ground at $x/D = 6.4$. However experimental data further downwind are not available to fully verify this aspect. The concentration predictions of CORMIX1 are in satisfactory agreement with the contour values for this complicated flow process.

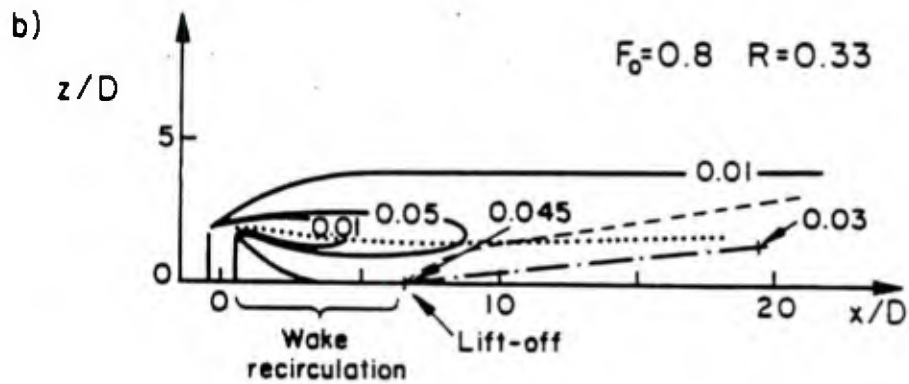
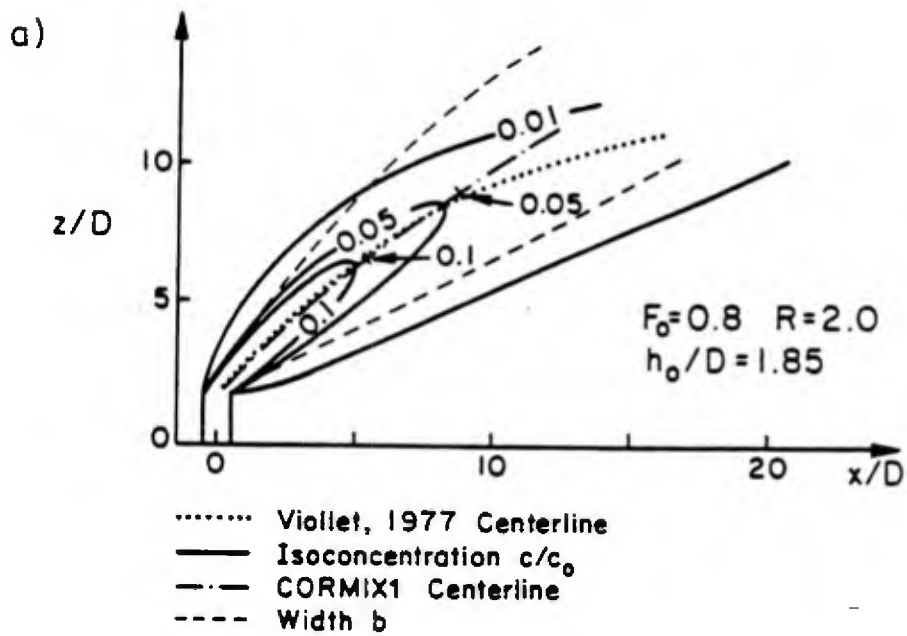

Figure 6.17 Strongly Buoyant Plume in Crossflow. a) Weak crossflow without attachment, b) strong crossflow with wake attachment.

6.2.4 Negatively Buoyant Flows With Upstream Spreading Along Bottom

The CORMIX1 prediction for the bottom interaction of negatively buoyant flows is shown in Figure 6.18 in comparison with the laboratory data of Tong and Stolzenbach (1979). This implies a flow class NV2, and CORMIX1 predicts bottom contact at $x = 0.45$ m, an upstream intrusion of 0.02 m and an intrusion thickness of 0.10 m, which is less than the visual data indicate. The predicted trajectory prediction tends to deflect somewhat less in the direction of the crossflow than the visual data indicate. The experiments conducted in a laboratory flume of limited width may exaggerate the extent of the bottom upstream intrusion for two reasons: First, due to the sidewalls there is less freedom for lateral spreading and therefore more upstream intrusion. Secondly, due to the viscous boundary layer in the ambient approach-flow there is less resistance (stagnation pressure) to the intrusion flow. For the analysis the ambient velocity was adjusted upward to 0.08 m/s from the reported mean velocity of 0.07 m/s to account for the contraction of the ambient flow caused by the presence of the density current in the laboratory channel. The important conclusion is that CORMIX1 recognizes this complicated interaction process with a negatively buoyant plume and upstream bottom buoyant spreading.

6.3 Summary and Appraisal

Seen as a whole, the preceding data/model comparisons indicate that CORMIX1 is a satisfactory modeling system for the mixing prediction of aqueous single port discharges in diverse conditions. CORMIX1 appears to be i) reliable and ii) accurate.

i) The system's reliability seems rooted in its robust classification scheme that determines which flow configuration (class) will occur for a given discharge/environmental situation before the appropriate simulation model is executed.

ii) The overall accuracy of the system is of the order of $\pm 50\%$ for the spatial definition of the flow zones (e.g. trajectories, width, etc.) and for tracer (pollutant) concentration. Given the broad range of flow conditions this accuracy level for a comprehensive, non-specialized model appears fully acceptable from an engineering standpoint. As usual, any lack of accuracy in such comparisons has to be viewed in the perspective of turbulent mixing processes with their intrinsic fluctuations and unsteadiness. Variations can also be caused by disturbing influences in experiments or field conditions; e.g. a shear

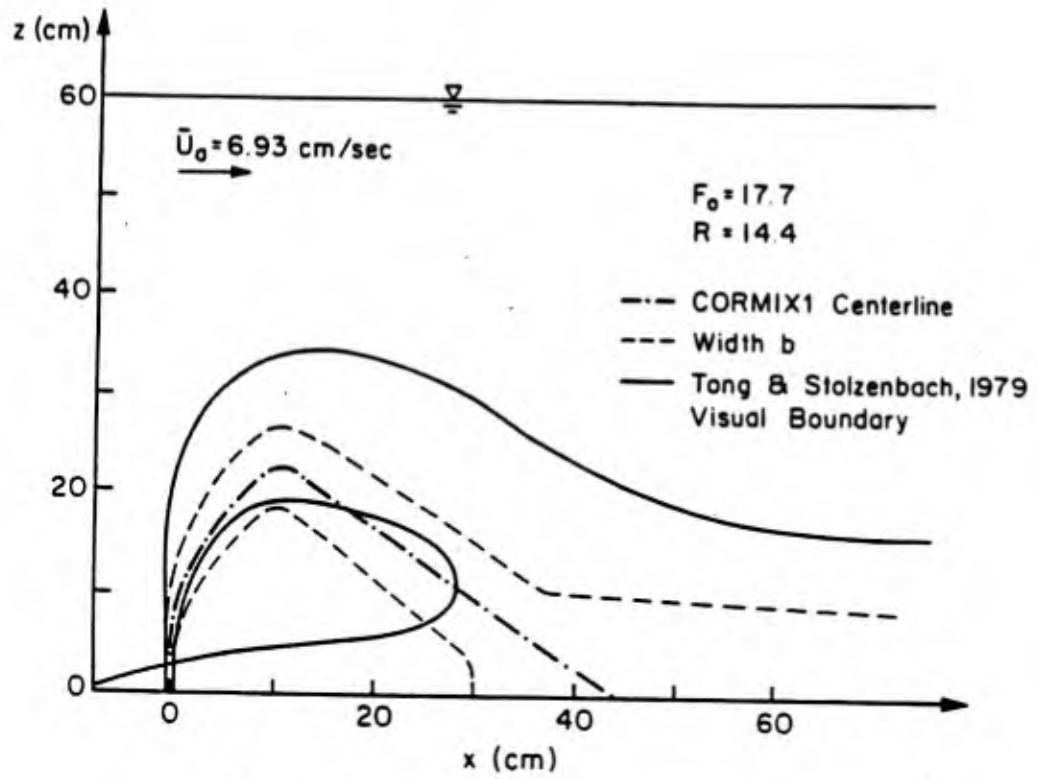

Figure 6.18 Interaction of Negatively Buoyant Jet with Bottom Boundary

flow instead of a uniform mean flow, and by different data interpretation and analysis techniques employed by researchers.

Emphasis has been placed in the data/model comparison on the near-field mixing characteristics of the effluent discharge, with comparatively less attention to the passive far-field mixing. This emphasis is of course motivated by the intended primary use of CORMIX1 as a predictive tool for mixing zone analysis. Another reason, however, is the fact that far-field mixing processes are reasonably well understood. The CORMIX1 far-field modules rely on standard plume models of the passive ambient diffusions processes (as discussed in Section 2.3) and the numerical values are well established (see Fischer, et al., 1979, Holley and Jirka 1986).

For many of the flow classes that can be predicted by CORMIX1, actual field or laboratory data are quite limited. One of the continuing goals of CORMIX1 is to update, enhance, and validate the knowledge base and predictive capability of the system as more information becomes available.

Chapter VII

Applications of CORMIX1

The purpose of this chapter is twofold: i) to give an overview of the typical steps of CORMIX1 application, including data input, in discharge design and mixing zone evaluation, and ii) to illustrate the flexibility of CORMIX1 using three hypothetical examples of highly divergent design or environmental conditions. The first case study represents a small toxic industrial discharge into a river (Section 7.1), the second is a toxic discharge into coastal waters illustrating the effects of density stratification (Section 7.2), and the third is a cooling water discharge into the ocean under different ambient currents (Section 7.3).

7.1 AB Chemical Company

This example illustrates a buoyant discharge in a bounded riverine section. The discharge flow represents a complex three-dimensional trajectory subject to three legal mixing criteria; a toxic dilution zone, a plume width criterion on a legal mixing zone defined by existing channel width, and a downstream region of interest. The analyst seeks pollutant concentrations at these locations. The analyst will use CORMIX1 to potentially improve dilution characteristics of the discharge by altering the discharge angles of the outfall design.

7.1.1 The Problem Statement

AB Chemical Company discharges a heated industrial effluent into the Ohio River through a submerged pipe outfall. The discharge flow is $0.053 \text{ m}^3/\text{s}$ and contains $500 \text{ } \mu\text{g}/\text{l}$ of a toxic substance. The material has a criterion maximum concentration (CMC) value of $25 \text{ } \mu\text{g}/\text{l}$. For summer conditions the discharge temperature is $48 \text{ }^\circ\text{C}$.

At the discharge site, the Ohio River is dammed as a run-of-the-river reservoir. The cross-section is approximately trapezoidal with a bottom width of 230 m and bank slopes of 1 in 3. The river depth is 12 m, and the velocity is $0.3 \text{ m}/\text{s}$. Typical summer temperatures are $20 \text{ }^\circ\text{C}$. The river roughness conditions are given by a Manning's n of 0.024.

The outfall is located 55 m from the berm line near the left bank. The right bank is under the jurisdiction of the State of Ohio. The initial design proposed for this discharge is as follows: The port is pointing directly offshore (normal to the ambient flow) and is directed horizontally along the bottom ($\theta_0 = 0^\circ$). The round port has a diameter of 15 cm and its center lies 0.4 m above the river bottom (see Figure 7.1).

The mixing zone limitations of the State of West Virginia have to be considered. For this case the mixing zone will be assumed to have a maximum width value equal to 10% of the river width, and the dilution values 3000 m downstream from the discharge point are of interest because of an intake to a public water supply on the Ohio shore. This will be labeled design case No. 1.

7.1.2 CORMIX1 Analysis

Design Case No. 1:

The first step in the analysis is to schematize the bounded cross-section as shown in Figure 7.1. Stream cross-sections are usually highly irregular; the trapezoidal cross-section represents an initial approximation of the actual stream cross-section. CORMIX1 assumes an equivalent rectangular cross-section as shown in Figure 7.1, which the analyst would approximate. Using DATIN, the site parameters are specified.

An advantage to logic programming is in error handling. It is simple to write rules that reject contradictory data. For example, when schematized as a rectangular cross-section, the schematized stream width is 262.75 m and the distance to the nearest bank (W. Va.) is 37.5 m. If the user made an error and responded that the distance to the nearest bank (West Virginia) was 225.25 m, i.e. the complement value, DATIN would respond:

```
The distance to nearest bank is in error.  
The value must be less than half the stream width.  
Recheck and re-enter a value less than or equal  
to 131.375 (m). [1]
```

and the user is given another chance to enter the correct value of 37.5 m.

After completing DATIN, the system executes PARAM, followed by CLASS. In CLASS the analyst is advised of the intermediate conclusions reached; i.e. the discharge is positively buoyant. CORMIX1 assigns a flow class H1A3 to

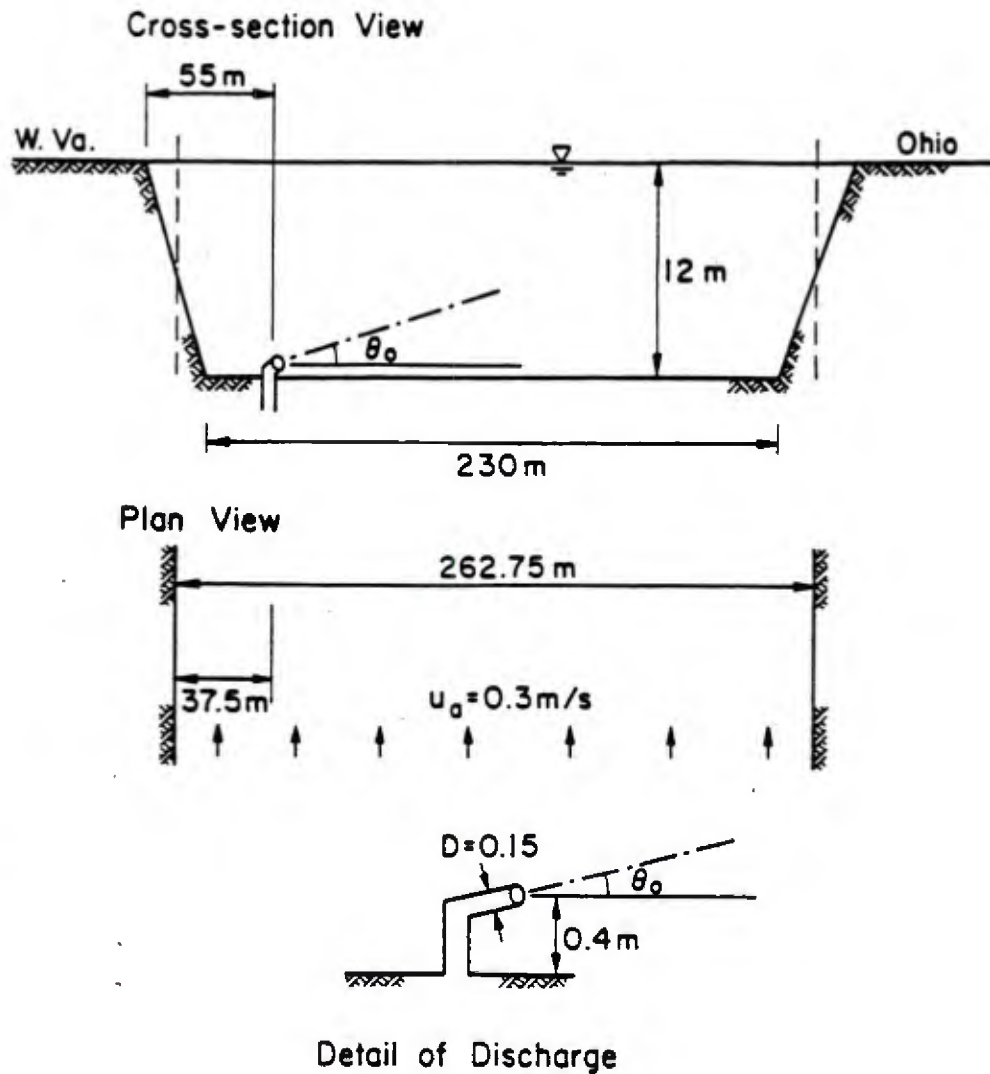

Schematization of Cross-section

Figure 7.1 AB Chemical Company: Schematization of Cross-section at the Discharge Site

the discharge indicating a Coanda attached jet with buoyant lift-off (attached wall jet, lift-off, strongly deflected plume (bdff), surface approach, buoyant surface spreading, passive diffusion).

After the program element HYDRO executes, the program element SUM summarizes the hydrodynamic simulation output for the design case. The results are shown in Figure 7.2. Figure 7.2a gives a longitudinal side view of the near-field and surface interaction. Figure 7.2b gives the detail of the near-field attachment looking downstream in the z-y plane. The buoyancy of the discharge causes lift-off at $x \approx 2.5$ m downstream. SUM notifies the user that surface interaction and thus the limit of the hydrodynamic mixing zone (HMZ), a region of strong initial discharge induced mixing (but of no legal significance), occur at $x \approx 117$ m downstream from the discharge point where the dilution value is $S \approx 620$ and the plume half-width b_h and vertical thickness b_v are both ≈ 7.4 m.

The toxic dilution zone (TDZ), where the tracer concentration falls below the CMC value, occurs at $x \approx 13$ m in the submerged plume region (bdff). SUM concludes that the criterion maximum concentration (CMC) value for the toxic discharge does not meet all legal restrictions. SUM notifies the user on the criteria checked for a TDZ; i) the discharge velocity was equal to or greater than the minimum value of 3.0 m/s, ii) the downstream distance of the TDZ (13 m) exceeded the maximum distance of 50 times the discharge length scale $L_0 = 0.13$ m, i.e. 6.5 m, iii) the downstream distance of the TDZ was less than the maximum distance of 5 times the water depth of 12 m, and finally iv) the downstream distance of the TDZ was less than the maximum of 10% of the distance to the LMZ. Thus SUM notifies the user that the discharge did not meet criterion (ii) for the toxic dilution zone. For this reason an alternative design case No. 2 will be evaluated.

Design Case No. 2:

Using the expert advice given by SUM an attempt is made to avoid the Coanda attachment of the discharge by increasing the vertical angle of the discharge. If attachment is averted, improvements in dilution within the near-field - and thus the TDZ - may be possible. These design changes will also illustrate the sensitivity of the model and flow classification when the vertical discharge angle is changed from $\theta_0 = 0^\circ$ to 30° ($\sigma_0 = 270^\circ$).

Using the new discharge orientation CORMIX1 indeed assigns an unattached flow class H1 to the discharge (mdnf, mdff, bdff, surface approach, buoyant surface spreading, passive mixing) indicating the increase in vertical

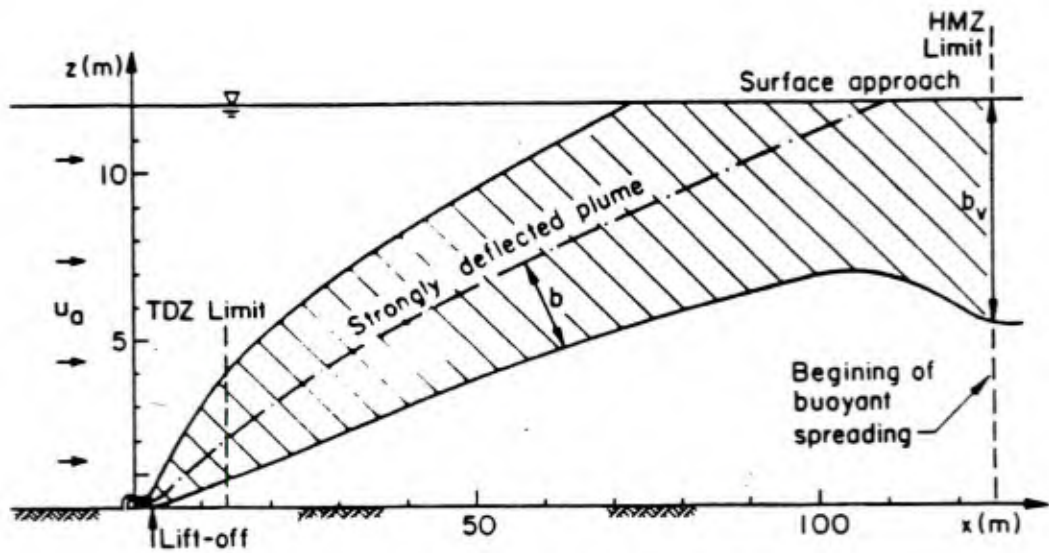

a) Longitudinal Side View (distorted scale)

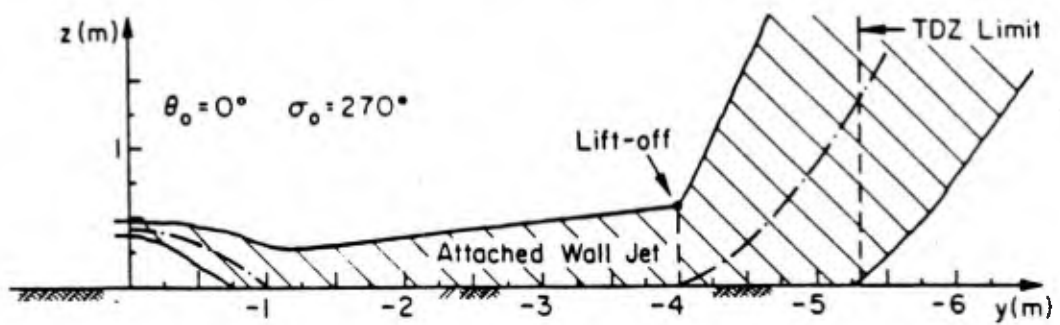

b) Vertical View Looking Downstream (undistorted)

Figure 7.2 AB Chemical Co. Design Case No. 1: Predictions (bottom attached jet)

discharge angle to 30° avoids Coanda attachment. A close-up of the near field of the discharge appears in Figure 7.3. This should be compared to the attached case as shown in Figure 7.2b.

SUM indicates the hydrodynamic mixing zone (HMZ) is limited to the surface contact at $x \approx 108$ m downstream from the discharge point with dilution value $S \approx 594$. The plume half-width b_h and thickness b_v are both ≈ 7.2 m, demonstrating that altering the discharge angles did not significantly improve mixing characteristics in the HMZ. In this case, only a small decrease in HMZ size and dilution is apparent.

The TDZ, however, shows a marked improvement of the unattached case. The CMC value of $25 \mu\text{g/l}$ is met at a downstream distance $x \approx 6.1$ m from the discharge point in the mdff region. Thus a shorter downstream distance than for the previous attached case is required to achieve the CMC value. Because of this, SUM concludes that the criterion maximum concentration (CMC) value for the toxic discharge now does meet all legal restrictions.

The overall plume shape, extending into the far-field, for this design case is shown in Figure 7.4. The transition from buoyant surface spreading plume to passive mixing occurs at $x \approx 835$ m. The plume contacts the left bank in the passive mixing region at $x \approx 1211$ m downstream from the discharge point, where the plume also becomes vertically fully mixed over the water depth ($b_v = 12$ m) m.

At the position of the public water supply located on the Ohio shore 3000 m downstream from the discharge point, the dilution value in the surface buoyant spreading region is $S \approx 6763$, and the plume half-width is $b_h \approx 97$ m (bank attached to left shoreline). The plume is vertically fully mixed ($b_v = 12$ m). Therefore, the plume does not influence the water supply intake.

The plume meets the legal mixing zone (LMZ) criteria of 10% of the stream width at $x \approx 199$ m downstream of the discharge in the buoyant surface spreading region, where $S \approx 582$. At this point the plume thickness is $b_v \approx 4.5$ m and the plume half-width is $b_h \approx 14$ m.

In summary, this example illustrates that the effect of altering discharge angles on mixing is often limited to the immediate near-field of the discharge. Plume attachments to the bottom should be avoided to insure rapid mixing in the near-field of the discharge. This is especially important for toxic dilution zones. However, altering discharge angles may have a limited effect on overall plume

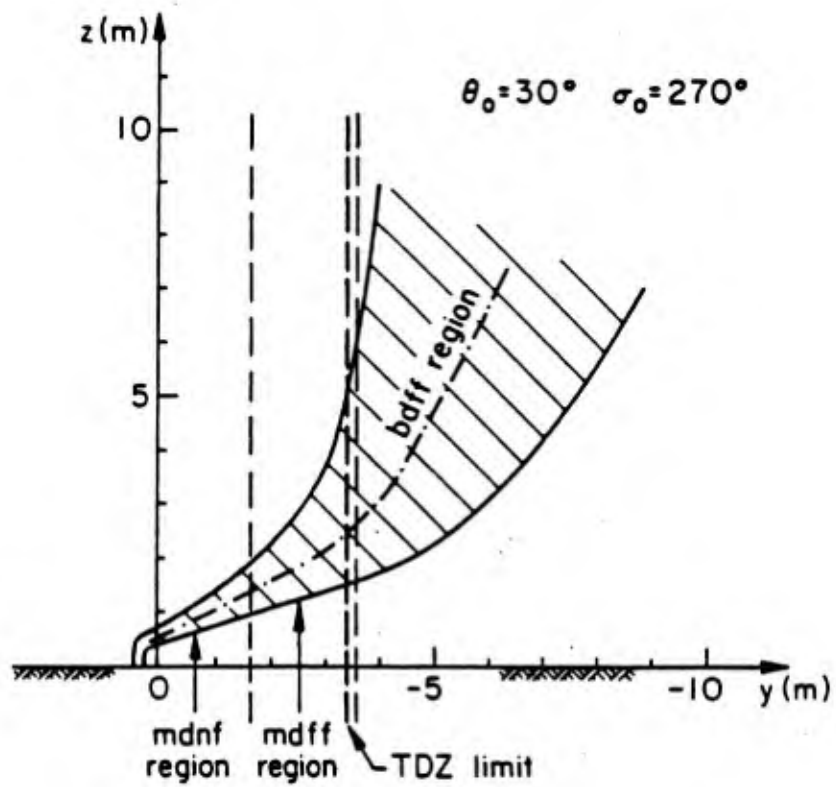
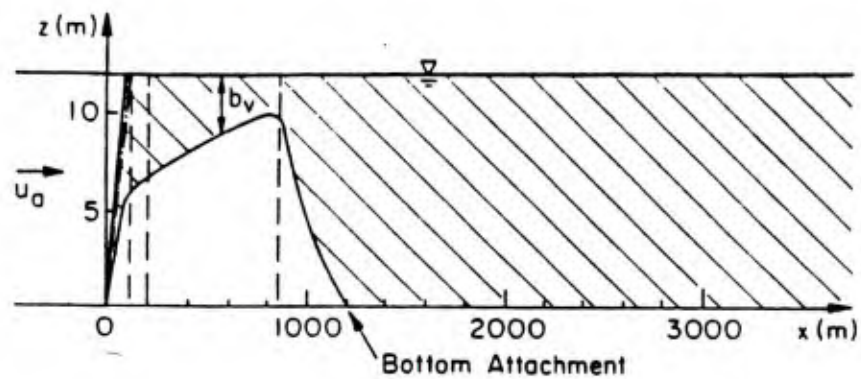
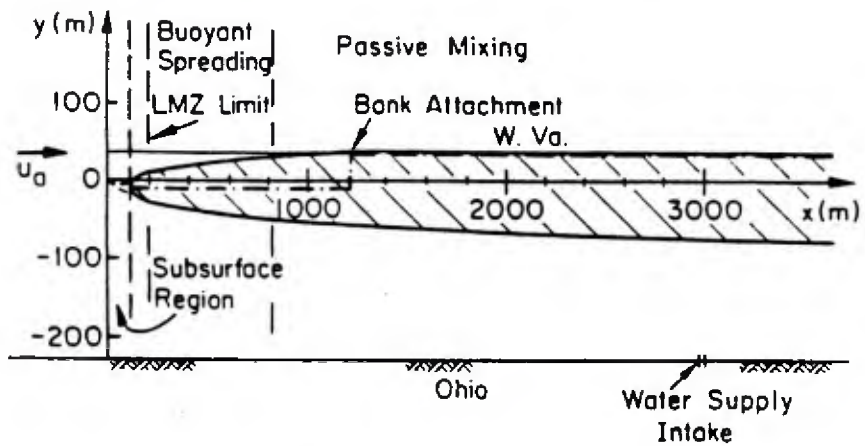

Figure 7.3 AB Chemical Co. Design Case No. 2: Close-up View of Unattached Buoyant Jet Near Discharge



a) Longitudinal Side View (distorted)



b) Plan View (distorted)

Figure 7.4 AB Chemical Co. Design Case No. 2: Overall Appearance of Discharge Plume

mixing behavior, especially in the far-field at large downstream distances from the source.

7.2 MN Municipal Treatment Plant

In this hypothetical example a mid-size municipality (about 100,000 inhabitants) is discharging its treated effluent into adjacent costal waters. A local metal processing plant is proposing to dispose its brine waste water containing toxic materials combined with the municipal effluent. This buoyant discharge is subject to three mixing criteria: a toxic dilution zone, a plume width criterion on the legal mixing zone, and a downstream region of interest. The analyst will use CORMIX1 to study the effect of typical winter and summer ambient density profiles on the mixing behavior of the discharge.

7.2.1 The Problem Statement

Typical winter and summer profiles have been measured in the discharge area and are shown in Figure 7.5a. The discharge is to be located 2000 m from shore at a local water depth of 24.4 m. The bathymetry is sloping approximately linearly from the shoreline.

The discharge port is round with a diameter of 0.5 m and extends about 0.5 m above the surrounding bottom with the vertical angle $\theta_0 = 30^\circ$ in the direction of the prevailing ambient current (co-flow, $\sigma_0 = 0^\circ$) which is of the order of 0.25 m/s. The design discharge flowrate is 0.6 m³/s and contains 100 $\mu\text{g}/\text{l}$ of a toxic metallic substance with a CMC of 10 $\mu\text{g}/\text{l}$. The discharge density for the mixture of municipal effluent and industrial brine is 1015 kg/m³. A public beach is located 2000 m down-current from the discharge point, so that plume characteristics at this distance are of interest.

7.2.2 CORMIX1 Analysis

The first step in the analysis would be to choose one of the four ambient stratification types as seen in Figure 5.3 to represent the actual density profiles. An ambient profile of (Stratification Type C, Figure 7.5b) is chosen to represent the August data, with surface density $\rho_s = 1022.6 \text{ kg}/\text{m}^3$, bottom density $\rho_b = 1024.4 \text{ kg}/\text{m}^3$, and ambient density jump $\Delta\rho = 0.83 \text{ kg}/\text{m}^3$ at the stratified layer height $H_s = 12.61 \text{ m}$. The schematized cross-section in this case of a linearly sloping bottom would assume would place the discharge 1000 m from "shore" in 24.4 m of water. A weak linear ambient density stratification (Stratification Type

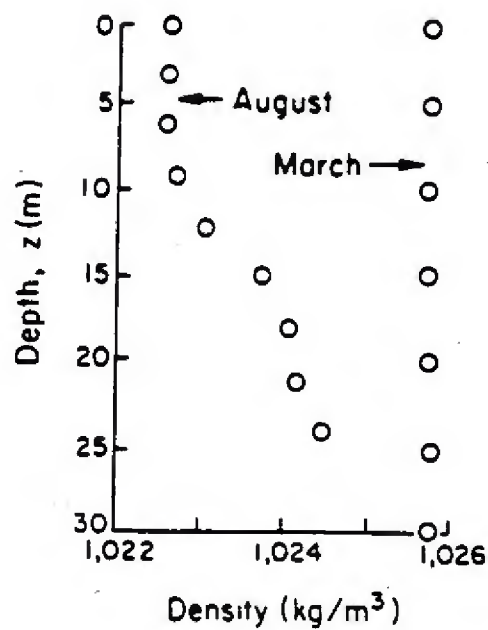

a) Actual Data

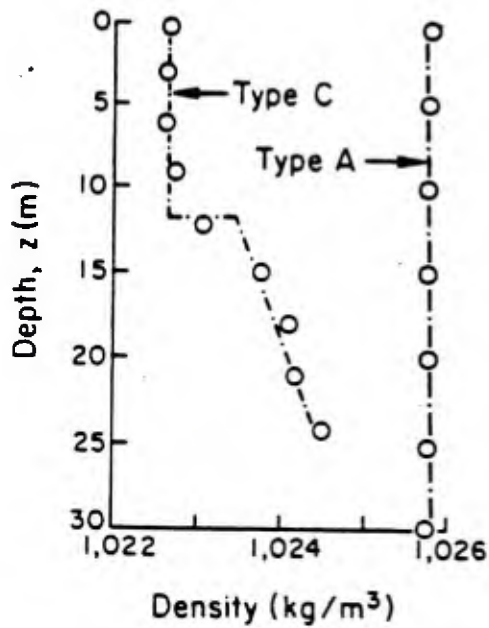

b) CORMIX1 Representation

Figure 7.5 MN Treatment Plant: Typical Density Profiles for Summer and Winter Conditions

A, Figure 7.5b) is chosen to represent the March data, with surface density $\rho_s = 1025.6 \text{ kg/m}^3$, bottom density $\rho_b = 1025.7 \text{ kg/m}^3$, and the stratified layer height H_s equal to the full discharge depth of 24.4 m.

Summer Design Case:

For the August design conditions, CORMIX1 concludes the flow will be confined to the lower density layer by the ambient density jump at the pycnocline and assigns a flow class H2 (mdnf, mdff, surface approach, buoyant spreading, passive diffusion). The simulation results are shown in Figures 7.6 and 7.7. SUM notifies the user that the hydrodynamic mixing zone (HMZ) occurs at $x \approx 54 \text{ m}$ downstream from the discharge point with plume centerline height $z \approx 12.6 \text{ m}$ (indicating a submerged plume trapped by the pycnocline density jump), the dilution value is $S \approx 39$, and the plume half-width b_h and thickness b_v are both $\approx 6.8 \text{ m}$.

The CMC (Figure 7.6) value occurs at $x \approx 16.4 \text{ m}$ from the discharge point in the mdff. SUM notifies the user that all criteria checked for the TDZ are satisfied.

The far-field behavior of the internally trapped plume is shown in Figure 7.7. The plume is still in the internal buoyant spreading regime. A very thin, but wide, layer of mixed effluent flow arises.

The legal mixing zone (LMZ, Figure 7.7) width of 200 m occurs in the subsurface buoyant spreading region at $x \approx 784 \text{ m}$ from the discharge point with a dilution $S \approx 76$. At the LMZ the flow is at the pycnocline height $z = 12.6 \text{ m}$ and not bank attached, with plume half-width $b_h \approx 100 \text{ m}$ and plume depth $b_v \approx 0.9 \text{ m}$.

At 2000 m from the outfall, the plume dilution is $S \approx 910$, and the flow half-width b_h and thickness b_v are $\approx 196 \text{ m}$ and 0.55 m , respectively. This indicates the subsurface buoyant spreading region still does not contact the shoreline near the public beach.

Winter Design Case:

For the March design conditions, CORMIX1 concludes the linear ambient density stratification is too weak to trap the flow, and a uniform ambient density is set equal to the depth average value of 1025.6 kg/m^3 . CLASS assigns a flow class H1 (mdnf, mdff, bdf, surface approach, buoyant spreading, passive diffusion) for the full water depth. It should be noted that the flow is classified as H1 (instead of H2 as in the previous example) because within the deeper layer the flow will develop a bdf region before surface contact. The simulation results for the near field are

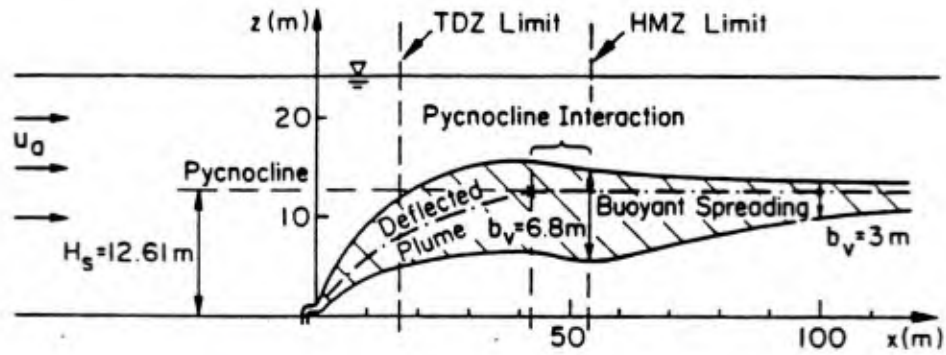

a) Side View (distorted)

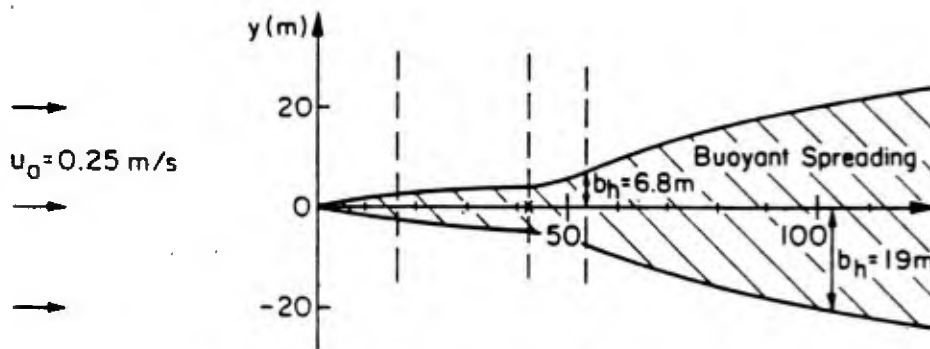

b) Plan View (undistorted)

Figure 7.6 MN Treatment Plant Summer Design Case: Internal Flow Trapping Caused by Pycnocline Density Jump

shown in Figure 7.8.

The hydrodynamic mixing zone (HMZ) occurs at surface contact at $x \approx 81$ m downstream from the discharge point with plume centerline height $z = 24.4$ m, dilution $S \approx 149$, and plume half-width b_h and thickness b_v both ≈ 13.3 m, indicating slightly greater HMZ dimensions and associated dilutions than the strongly stratified August design.

For the March design the legal mixing zone (LMZ) width of 200 m occurs in the surface buoyant spreading region at $x \approx 753$ m from the discharge point with a larger dilution $S \approx 248$. At the LMZ the surface flow does not contact the shoreline, with plume half-width $b_h \approx 102$ m and plume depth $b_v = 2.9$ m.

The CMC value occurs at $x \approx 16$ m from the discharge point, again indicating that all criteria for the TDZ are met for this discharge design condition.

In summary, this example illustrates the flexibility of CORMIX1 in predicting flow behavior in density stratified environments, where plume trapping by the pycnocline may inhibit dilution.

7.3 PQ Power Company

This design example represents an ocean cooling water outfall from a small steam-electric power plant in relatively shallow water and varying ambient tidal currents with weak ambient density stratification. There is no legal mixing zone under consideration for this discharge. But because the cooling water intake structure for the power plant is located on the shoreline 1000 m from the discharge point, the behavior of the heated effluent over this region is sought.

7.3.1 The Problem Statement

The outfall is located 300 m offshore at a local water depth of 5.0 m. The bathymetry is given by an approximately flat shelf region. Available site data indicate a linear ambient density profile with a surface temperature of 18°C and a bottom temperature of 15°C .

The outfall port is round with a diameter of 1.0 m which extends about 0.5 m above the surrounding bottom. The cooling water is discharged vertically at a flowrate of $3.0\text{ m}^3/\text{s}$. The design discharge temperature is 30°C . The discharge site is characterized by varying tidal currents between 0.2 m/s and 0.8 m/s.

shown in Figure 7.8.

The hydrodynamic mixing zone (HMZ) occurs at surface contact at $x \approx 81$ m downstream from the discharge point with plume centerline height $z = 24.4$ m, dilution $S \approx 149$, and plume half-width b_h and thickness b_v both ≈ 13.3 m, indicating slightly greater HMZ dimensions and associated dilutions than the strongly stratified August design.

For the March design the legal mixing zone (LMZ) width of 200 m occurs in the surface buoyant spreading region at $x \approx 753$ m from the discharge point with a larger dilution $S \approx 248$. At the LMZ the surface flow does not contact the shoreline, with plume half-width $b_h \approx 102$ m and plume depth $b_v = 2.9$ m.

The CMC value occurs at $x \approx 16$ m from the discharge point, again indicating that all criteria for the TDZ are met for this discharge design condition.

In summary, this example illustrates the flexibility of CORMIX1 in predicting flow behavior in density stratified environments, where plume trapping by the pycnocline may inhibit dilution.

7.3 PQ Power Company

This design example represents an ocean cooling water outfall from a small steam-electric power plant in relatively shallow water and varying ambient tidal currents with weak ambient density stratification. There is no legal mixing zone under consideration for this discharge. But because the cooling water intake structure for the power plant is located on the shoreline 1000 m from the discharge point, the behavior of the heated effluent over this region is sought.

7.3.1 The Problem Statement

The outfall is located 300 m offshore at a local water depth of 5.0 m. The bathymetry is given by an approximately flat shelf region. Available site data indicate a linear ambient density profile with a surface temperature of 18°C and a bottom temperature of 15°C .

The outfall port is round with a diameter of 1.0 m which extends about 0.5 m above the surrounding bottom. The cooling water is discharged vertically at a flowrate of $3.0\text{ m}^3/\text{s}$. The design discharge temperature is 30°C . The discharge site is characterized by varying tidal currents between 0.2 m/s and 0.8 m/s.

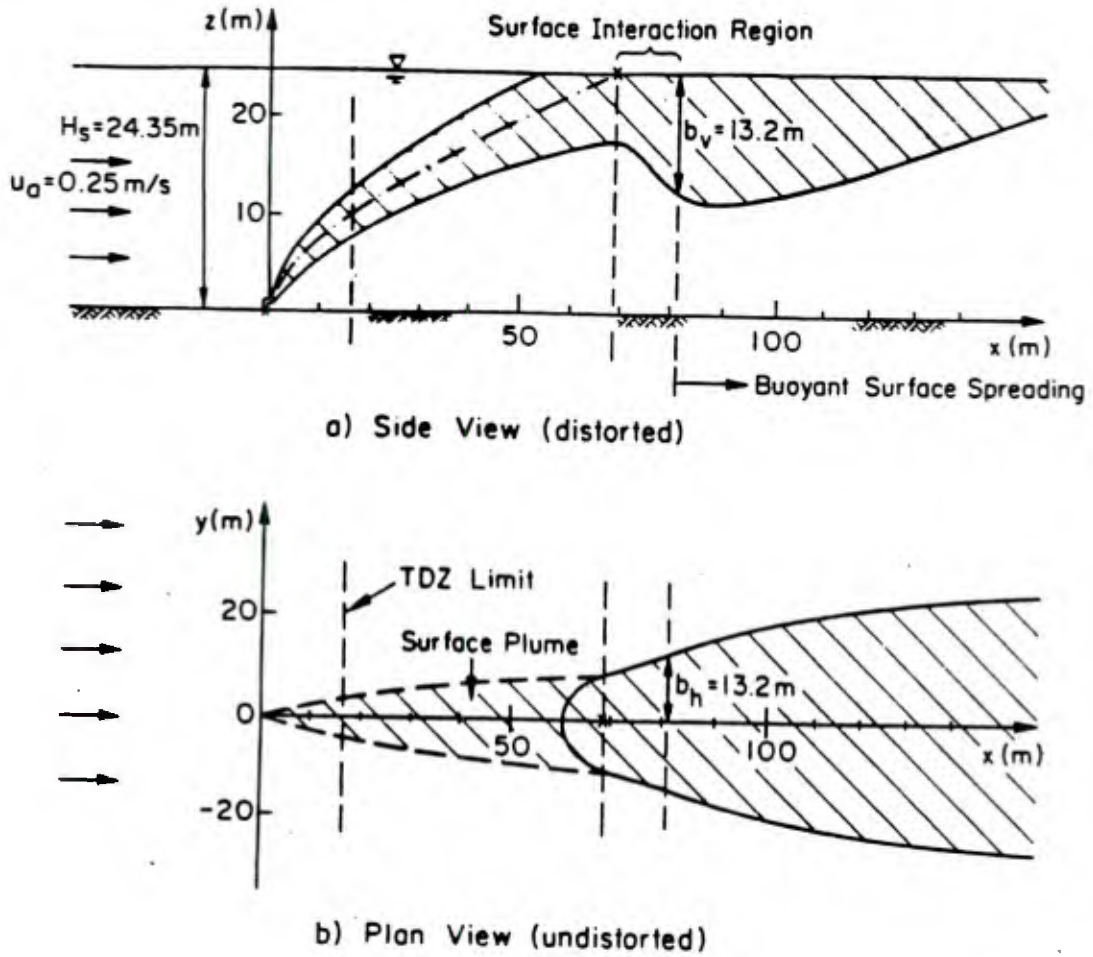

Figure 7.8 MN Treatment Plant Winter Design Case: Plume Surface Interaction

7.3.2 CORMIX1 Analysis

Low Current Case:

For the minimum ambient current speed of $u_a = 0.2$ m/s, CORMIX1 concludes linear ambient density stratification resulting from the difference in surface and bottom temperatures is weak and dynamically unimportant. CLASS assigns a flow class V5 (mdnf, bdnf, surface impingement with upstream spreading, buoyant surface spreading, and passive mixing). The simulation results are shown in Figure 7.9.

CORMIX1 indicates an upstream intrusion length of $x \approx 66$ m with the intrusion layer maximum thickness of 4.34 m at the leading front (stagnation point). The buoyant intrusion rapidly collapses into a wide and shallow density current. At the edge of the HMZ the density current has a half-width b_h of 173 m and a thickness b_v of only 0.15 m.

Farther downstream in the far-field, the dilution is still limited to $S \approx 3.5$ at $x \approx 1000$ m (not shown in Figure 7.9) from the outfall where the buoyant surface spreading plume half-width b_h and thickness $b_v \approx 189$ m and 0.14 m, respectively, indicating very little mixing under a low ambient crossflow. The plume would not influence the cooling water intake under these conditions.

Note that CORMIX1 does not include any decay processes in the effluent. In practice, the heated effluent in this design case would undergo surface heat exchange processes which would be reasonably strong due the small degree of mixing. A discussion of the adaptation of CORMIX1 to include such decay is given in Section 7.4.4.

High Current Case:

For the maximum ambient current speed of $u_a = 0.8$ m/s, CORMIX1 concludes that the weak linear ambient density stratification is again unimportant. CLASS assigns a flow class V4 (mdnf, boundary impingement with full vertical mixing; buoyant surface spreading, and passive mixing). The simulation results are shown for the near-field in Figure 7.10, indicating that the stronger ambient current prevents buoyant upstream intrusion, and an unstable mixing zone occurs around the discharge. The plume makes a transition from buoyant surface spreading to passive mixing at $x = 703$ m from the outfall (not shown in Figure 7.10). However, the stratified passively mixing plume only slowly approaches the shoreline. At 1000 m downstream from the outfall, the dilution is still limited to $S \approx 34$ and the plume half-width $b_h \approx 40.5$ m and the thickness $b_v \approx 1.5$ m. Thus, one can

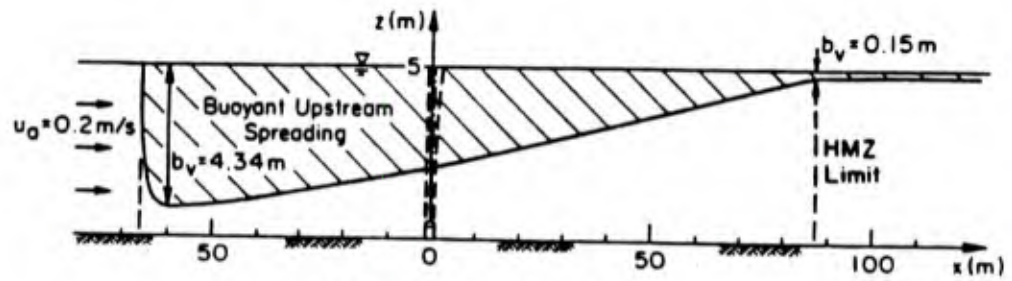

a) Side View (distorted)

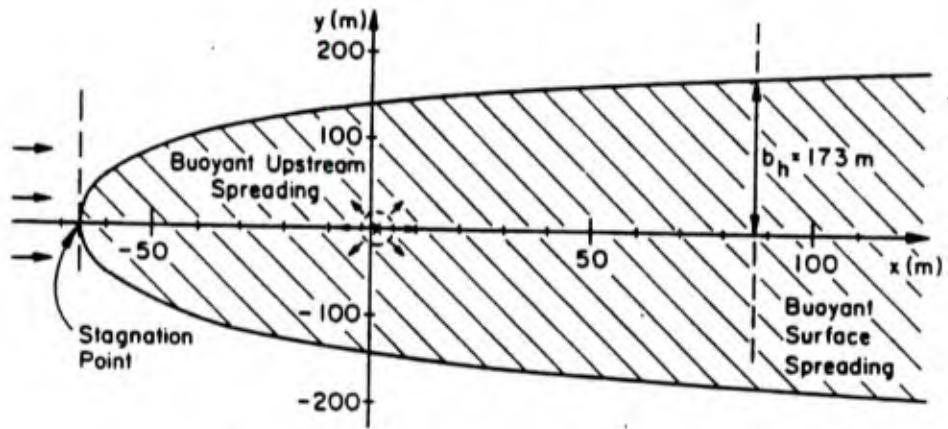

b) Plan View (distorted)

Figure 7.9 PQ Cooling Water Outfall in Low Current Design Case: Near-Field Plume Behavior

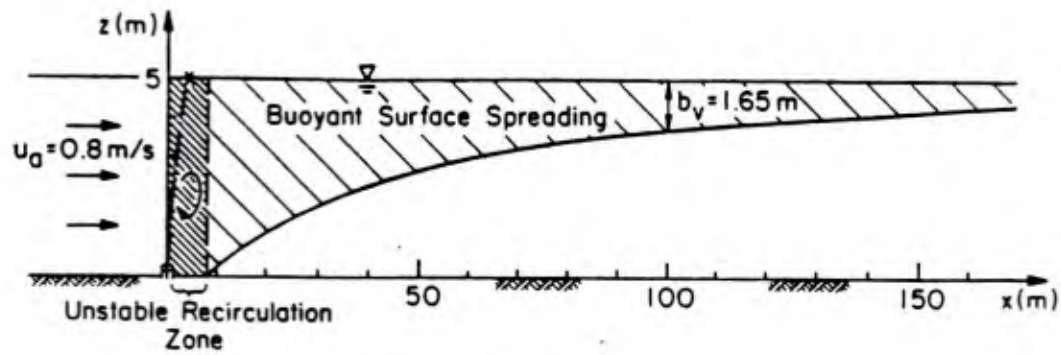

a) Side View (distorted)

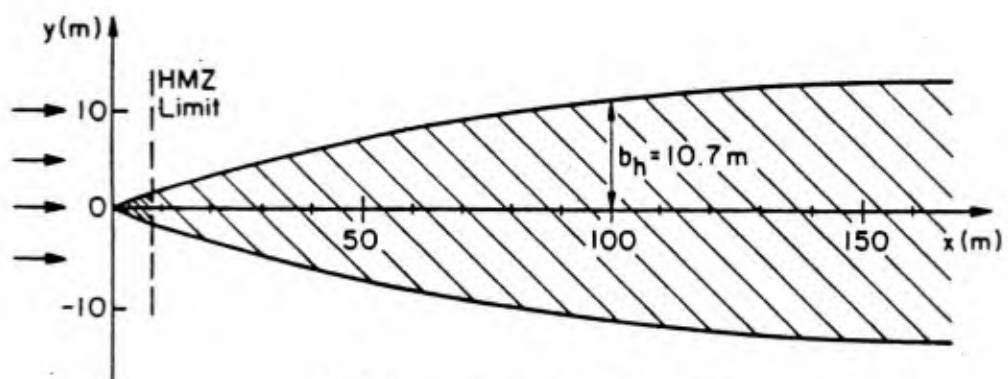

b) Plan View (undistorted)

Figure 7.10 PQ Cooling Water Outfall High Current Design Case: Near-Field Plume Behavior

conclude the cooling water intake would not experience a temperature rise due to heated discharge re-entrainment.

In conclusion, this example illustrates that ambient current can have a significant effect on discharge mixing and plume behavior, especially on discharges with strong buoyancy dominated boundary interaction and subsequent buoyant spreading. Because of the normal variation in natural systems, the analyst should study plume characteristics under a range of ambient environmental conditions.

In all three of the previous examples, the buoyant spreading region extends to large distances downstream from the outfall. Discharge buoyancy tends to stabilize the plume in the far-field and prevents the transition to passive ambient mixing, which in general, is a more efficient mixing mechanism. Toxic dilution zone criteria may be most restrictive and occur in the near-field in the vicinity of the discharge. The legal mixing zone commonly occurs in the far-field in either the buoyant spreading or passive mixing region.

7.4 Comments on the Application of CORMIX1

As mentioned in Chapter IV it is expected that CORMIX1 will be a general predictive system applicable to the majority (better than 95%) of submerged single port discharge/environmental conditions. It is impossible, however, to devise a system that will analyze all conceivable submerged discharges. For this reason, CORMIX1 intentionally contains several internal criteria (limitations) designed to avoid system misuse for such extreme conditions. These limitations are summarized in Section 7.4.1. However, an experienced user can modify the data input to allow for CORMIX1 analysis for conditions (e.g. near-surface discharges) that are seemingly outside the normal range of system applicability. Hints for such system application are given in Section 7.4.2

7.4.1 Limitations of CORMIX1

CORMIX1 is devised for submerged single port discharges in water of variable depth H (see Figure 7.11). Thus the discharge is assumed to be located near the bottom of the water body. CORMIX1 uses the applicability criterion for the height of the discharge port h_0

$$h_0 \leq 0.33H \quad (7.1)$$

Eq. (7.1) is needed to assure a valid test for deep/shallow discharge stability in the flow classification scheme.

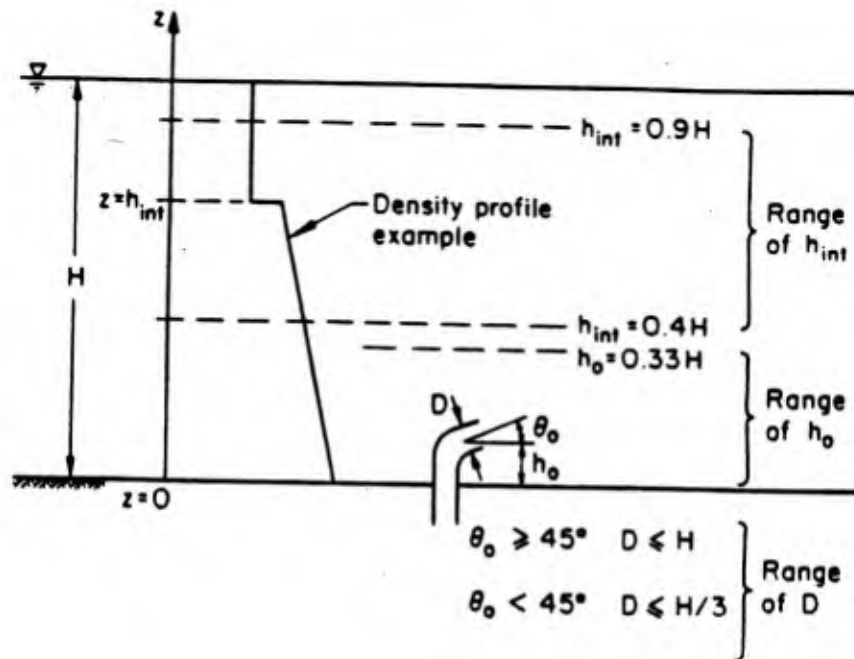

Figure 7.11 Parameter Range of CORMIX1 Applicability

Also the discharge port diameter D must not exceed practically unrealistic (yet theoretically conceivable) values of the order of the water depth, thus for near-vertical discharges

$$D \leq H \quad (7.2)$$

and for near-horizontal discharges

$$D \leq 0.5H \quad (7.3)$$

Finally, the height of the pycnocline (i.e. thickness of the lower layer) h_{int} must be more than 40% but less than 90% of the water depth

$$0.9H \geq h_{int} \geq 0.4H \quad (7.4)$$

7.4.2 Hints for CORMIX1 Use in Extreme Conditions

7.4.2.1 (Near-)Surface Discharges

As an example, assume that a positively buoyant discharge is located at a small submergence - perhaps at 10% of the depth - below the free surface of an unstratified water body. Clearly, the condition of Eq. 7.1 is violated so CORMIX1 cannot be used with such input data (in fact the system will reject this input, and ask the user to check the data!).

Yet a valid application of CORMIX1 for buoyant discharges is still possible if the reverse situation - i.e. a "mirror image" - of the ambient/discharge configuration is considered using the water surface as the plane of symmetry. In this situation the discharge jet - now with reversed "negative" buoyancy - is located near the "bottom". After appropriate data input, CORMIX1 would conclude a negatively buoyant flow class (NH) and all system predictions have to be interpreted in the coordinate system of the mirror image.

Even more complicated ambient stratification conditions, can be handled in this mirror image interpretation as long as careful attention is paid to the specification of the reverse stable profile.

However, CORMIX1 is not applicable to (near-)surface discharge conditions that i) experience strong shoreline interaction, or ii) have a highly non-uniform cross-section (aspect ratio) as in a channel inflow.

i) The near-field processes considered in CORMIX1 are valid only for offshore conditions and do not include any shoreline (bank) interaction (Such interaction is allowed only in the far-field in CORMIX1). Shoreline interaction

processes may sometimes dominate surface discharge dynamics as discussed in detail by Chu and Jirka (1986).

ii) Surface discharges may often have a large cross-sectional aspect ratio (e.g. width/depth ratio of a channel inflow). Since CORMIX1 neglects the geometric details of the zone of flow establishment it is valid only for round or near-square cross-sections with maximum aspect ratio values of about 3:1.

7.4.2.2 Elevated Discharges

If a discharge is still well submerged but elevated above one third of the water depth as specified by Eq. 7.1, then CORMIX1 can still be used in the following iterative fashion:

Case i): For a strongly buoyant jet that tends to quickly rise to the surface, assume the water bottom lies higher so that the port elevation relative to the reduced depth is within the 33% limit expressed in Eq. 7.1. The CORMIX1 predictions will be valid if they indicate a stable flow class for this reduced depth condition without any unstable recirculation.

Case ii): For a strongly negatively buoyant jet that would rapidly sink towards the bottom, assume the water surface is sufficiently higher so that Eq. 7.1 is met. Evaluate the CORMIX1 predictions to check for stable discharge configurations that would not interact with the actual water surface.

Case iii): If unstable discharge conditions are expected (this would be indicated if the above assumptions are violated) then the actual port elevation is frequently of secondary importance, while the water depth is the primary parameter. In this case, a reduced port elevation - within the limits of Eq. 7.1 - can be specified.

Clearly the experienced user will proceed with a careful iterative evaluation of such complex, and perhaps unusual, cases that fall outside the normal CORMIX1 problem domain of deeply submerged single port discharges.

7.4.3 Applications to Non-Dimensional Coordinate Systems

Available data on buoyant jet mixing processes are usually presented in non-dimensional form. Often the port diameter D is used for length normalization and the non-dimensional parameters F_0 , R , and T (Eqs. 6.1, 6.2, and 6.3,

respectively) are given. Also the coordinate system is frequently put at the discharge orifice.

Since CORMIX1 uses the SI System of units (e.g. length expressed in meters) a simple numerical comparison is achieved by preparing the buoyant jet input data as follows: $D = 1 \text{ m}$, $\rho_a = 1000 \text{ kg/m}^3$, $\rho_b = 990 \text{ kg/m}^3$, $u_0 = 0.3132F_0$, $u_a = u_0/R$, $h_0 = 0 \text{ m}$, and $H^* = 1000 \text{ m}$ (unless the actual normalized water depth $H/D = H^*$ is known in the experiment, in which case $H = H^* \text{ m}$). Furthermore, for linearly stratified cases, the ambient density $\rho_a(H)$ at the water surface is specified by $\rho_a(H) = 1000(1 - 10/T) \text{ kg/m}^3$, where T is the stratification parameter given by Eq. (6.3), and the ambient bottom density $\rho_b = 1000 \text{ kg/m}^3$. If this convention is made, all lengths (m) predictions by provided by CORMIX1 can be conveniently interpreted as predictions normalized by the diameter D , i.e. they are numerically the same.

Since the port height h_0 is zero for these simulations, CORMIX1 assumes a bottom at $z = 0$, and hence for many cases an attachment process is indicated. However, in program element CLASS the user can override this attachment and CORMIX1 will provide predictions for the unconfined and unattached flow.

7.4.4 Adaptation to First-Order Reaction Processes

CORMIX1 assumes a conservative pollutant or tracer in the effluent. This assumption is reasonable since the emphasis of CORMIX1 is on initial mixing mechanisms that have very short time scales (order of minutes) much less than the typical reaction times for growth or decay of most, though not all, discharged substances.

If the physical, chemical, and/or biological reaction mechanism can be represented as a first-order process with reaction time constant K_r [s^{-1}], then the user can convert the conservative pollutant concentration c predicted by CORMIX1 in the far-field, i.e. the buoyant spreading and ambient diffusion regimes. The conversion to reacting substances yields a non-conservative concentration c_n

$$c_n = c \exp(-K_r x/u_a) \quad (7.5)$$

in which x/u_a represents the travel time in the far-field. This simple adaptation is acceptable if the reaction time scale, $1/K_r$, is sufficiently larger than the travel time to the end of the near-field (i.e. the hydrodynamic mixing zone), x_{HMZ}/u_a . For substances with faster reactions more detailed analyses which consider the actual travel time within the near-field have to be performed.

Chapter VIII

Conclusions and Recommendations

U.S. water quality policy allows for a mixing zone as a limited area or volume of water where the initial dilution of a discharge occurs. Water quality standards apply at the edge and outside of the mixing zone. Toxic discharges have additional regulatory restrictions, which require additional dilution analyses. The implementation of this policy in the National Pollution Discharge Elimination System (NPDES) permitting process places the burden of prediction of initial dilution on both regulators and dischargers. Given a myriad of possible discharge configurations, ambient environments, and mixing zone definitions, the analyst needs considerable training and expertise to conduct accurate and reliable mixing zone analysis. Against this background, a micro-computer based expert system, the Cornell Mixing Zone Expert System (CORMIX), was developed as a tool for effluent flow prediction and mixing zone analysis.

Subsystem CORMIX1 predicts the dilution and trajectory of a single port buoyant (positively, negatively, or neutrally) discharge into a uniform or stratified density environment with or without crossflow. CORMIX1 uses knowledge and inference rules obtained from hydrodynamic expertise to classify and predict mixing processes. CORMIX1 gathers the necessary data, checks for data consistency, assembles and executes the appropriate hydrodynamic simulation models, interprets the results of the simulation in terms of the legal requirements including toxic discharge criteria, and suggests design alternatives to improve dilution characteristics.

CORMIX1, with its emphasis on rapid initial mixing, assumes a conservative pollutant discharge neglecting any physical, chemical, or biological reaction or decay process. However, the predictive results can be readily converted to adjust for first-order reaction processes.

The results of the hydrodynamic simulation are in good to excellent agreement with field and laboratory data and other available simulation models. In particular, CORMIX1 correctly predicts a wide range of highly complex discharge situations involving boundary interactions, stratified terminal layers, buoyant intrusions, and bottom attachments, all features which are not predicted by other currently

available initial mixing models. Overall CORMIX1 appears to be an excellent first cut tool for the analyst.

As more data become available and experience with using the expert system is obtained, the hydrodynamic flow protocols in the flow classification system should be further analyzed along with verification of the constants used within the model. For some possible flow configurations, the existing data base is limited for conducting rigorous validation studies indicating a need for additional field and laboratory data. Also the implementation of computer graphics should be pursued in order to display the results of CORMIX1 predictions.

References

1. Abdelwahed, S. T., and V. H. Chu (1978), "Bifurcation of Buoyant Jets in Cross Flow", Technical Rept. No. 78-1, Department of Civil Engineering and Applied Mechanics, McGill University, Montreal, Canada.
2. Abraham, G. (1963), "Jet Diffusion in Stagnant Ambient Fluid", Delft Hydraulics Lab., Publ. No. 29.
3. Akar, P. J. (1989), "CORMIX2: An Expert System for Hydrodynamic Mixing Zone Analysis of Conventional and Toxic Submerged Multiport Discharges", M.S. Thesis, School of Civil and Environmental Engineering, Cornell University, Ithaca, N.Y.
4. Alam, A. M. Z., D. R. F. Harleman, and J. M. Colonell (1982), "Evaluation of Selected Initial Dilution Models", Journal of the Environmental Engineering Division, ASCE, Vol. 108, No. EE1, February. pp 159-185.
5. Allan Hancock Foundation, University of Southern California (1964), "Final Report on an Investigation on the Fate of Organic and Inorganic Wastes Discharge into the Marine Environment and Their Effects of Biological Productivity", September 15.
6. Anderson, J. L., F. L. Parker, and B. A. Benedict (1973), "Negatively Buoyant Jets in a Crossflow", Environmental Protection Technology Series, U.S.E.P.A., Washington, D.C.
7. Anwar, H. O. (1972), "Measurements on Horizontal Buoyant Jets in Calm Ambient Fluid", La Houille Blanche, Vol. 27, No.4.
8. Ayoub, G. M. (1971), "Dispersion of buoyant jets in a flowing ambient fluid", Ph.D. Thesis, Dept. of Civil Engineering, Imperial College (University of London), March 1971.
9. Barnwell, T. O., L. C. Brown, and W. Marek (1985), "Development of a prototype expert advisor for the enhanced stream water quality model QUAL2E", Internal Report, Environmental Research Laboratory, Office of Research and Development, U.S.E.P.A., Athens, Georgia, September, 1985.
10. Benjamin, T. B. (1968), "Gravity Currents and Related Phenomena", J. Fluid Mechanics, Vol. 31, pt. 2.

11. Briggs, G. A. (1969), Plume Rise, U.S. Atomic Energy Commission, Division of Technical Information, Oak Ridge, Tennessee.
12. Cederwall, K. (1963), "The Initial Mixing of Jet Disposal into a Recipient," Tech. Rep. 14 and 15, Div. of Hydraulics, Chalmers Institute of Technology, Goteborg, Sweden.
13. Chen, J. C. (1980), "Studies on Gravitational Spreading Currents", Rep. KH-R-40, W.M. Keck Laboratory of Hydraulics and Water Resources, California Institute of Technology, Pasadena, Calif.
14. Chu, V. H. and G. H. Jirka (1986), "Surface Buoyant Jet and Plumes", Encyclopedia of Fluid Mechanics, Chapt. 25., Gulf Publishing Co., Houston, Texas.
15. Clocksin, W. F. and C. S. Mellish (1984), Programming in Prolog, 2nd ed., Springer-Verlag.
16. Congressional Research Service, (1977). "Legislative History of the Clean Water Act 1977", Congressional Research Service, Library of Congress, October 1978, No. 95-14 p. 330.
17. Davidson, M. J. (1989), "The Behavior of Single and Multiple, Horizontally Discharged, Buoyant Flows in a Non-Turbulent Coflowing Ambient Fluid", Ph.D. Thesis, Department of Civil Engineering, University of Canterbury, Christchurch, New Zealand.
18. Doneker, R. L. and G. H. Jirka (1988), "CORMIX1: An Expert System for Mixing Zone Analysis of Conventional and Toxic Single Port Aquatic Discharges", USEPA, Env. Res. Lab., Athens, GA. NTIS Rept. No. PB 88-220 504/AS.
19. Electric Power Research Institute (EPRI) (1981), "Studies on Mathematical Models for Characterizing Plume and Drift Behavior Form Colling Towers", Vol. 1. Argonne National Laboratory, Interim Report, EPRI CS-1683.
20. Fan, L. N. (1967), "Turbulent Buoyant Jets into Stratified or Flowing Ambient Fluids," Rep. KH-R-18, W.M. Keck Laboratory for Hydraulics and Water Resources, California Institute of Technology, Pasadena, Calif.
21. Fay, J. A., M. Escudier, and D. P. Hoult (1970), "A Correlation of Field Observation of Plume Rise", J. Air Pollution Control Association, Vol. 20., No. 33, pp. 6818-6835.

22. Findley and Farber (1983), Environmental Law in a Nutshell, West Publishing Co.
23. Fischer, H. B. et al. (1979), Mixing in Inland and Coastal Waters, Academic Press, New York.
24. Fong, H. L. M. (1980), "Bifurcation Phenomenon of Buoyant Jets in Stratified or Homogeneous Crossflow", M.S. Thesis, School of Civil and Environmental Engineering, Cornell University, Ithaca, New York.
25. Gaschnig, J., Reboh, and J. Reiter (1981), "Development of a Knowledge-Based Expert System for Water Resources Problems", Palo Alto, Calif.
26. Hansen, J. and H. Shroder (1968), "Horizontal Jet Dilution Studies by Use of Radioactive Isotopes", Acta Ploytechnica Scandinavia, Civil Engineering and Building Construction Series No. 49, Copenhagen, Denmark.
27. Holley, E. R. and G. H. Jirka (1986), "Mixing in Rivers", Technical Report E-86-11, U.S. Army Corps of Engineers, Washington, D.C.
28. Jordinson, R. (1956), "Flow in a jet directed normal to the wind". Aeronautical Research Council, London, R. and M, 3074.
29. Jirka, G. H. and D. R. F. Harleman (1973), "The Mechanics of Submerged Multiport Diffusers for Buoyant Discharges in Shallow Water", M.I.T., Ralph M. Parsons Laboratory for Water Resources and Hydrodynamics, Tech. Rep No. 169.
30. Jirka, G. H., J. M. Jones, and F. E. Sargent (1980), "Theoretical and Experimental intermediate Field Dynamics of Ocean Energy Conversion Plants", Progress Report, 1978-1979, School of Civil and Environmental Engineering, Cornell University.
31. Jirka, G. H., (1980), Discussion of "Line Plume and Ocean Outfall Dispersion" by Roberts, P. J. W. (1979), Journal of the Hydraulics Division, ASCE, HY12, December.
32. Jirka, G. H. and L.M. Fong (1981), "Vortex Dynamics and Bifurcation of Buoyant Jets in Crossflow", Journal of the Hydraulics Division, American Society of Civil Engineers, Vol. 107, No. EM3, June.
33. Jirka, G. H. and J. H.-W. Lee (1987), Hydraulic Structures Design Manual, E. Naudascher, Ed., Vol. 10. International Association of Hydraulic Research, (in print).

34. Jones, J. M., G. H. Jirka, and D. A. Caughey (1985), "Numerical Techniques for Steady Two-Dimensional Transcritical Stratified Flow Problems, with an Application to the Intermediate Field Dynamics of Ocean Thermal Energy Conversion Plants", Report No. ANL/EES-TM-27\1, Argonne National Laboratory.
35. Koh, R. C. and N. H. Brooks (1975), "Fluid Mechanics of Waste Water Disposal in the Ocean", Annual review of Fluid Mechanics, Vol. 7, pp. 187-211.
36. Larsen, J. and T. Sorensen (1968), "Buoyancy Spread of Wastewater in Coastal Regions", Eleventh Conference on Coastal Engineering, London, Vol. 2.
37. Lee, J. H. W. and G. H. Jirka (1981), "Vertical Round Buoyant Jet In Shallow Water", Journal of the Hydraulics Division, American Society of Civil Engineers, Vol. 107, No. HY12, December.
38. Liseth, P. (1970), "Mixing of Merging Buoyant Jets from a Manifold in Stagnant Receiving Water of Uniform Density", Hydraulic Engineering Laboratory, University of California, Berkeley, California. Tech. Rept. HEL 23-1.
39. List, E. J. and J. Imberger (1973), "Turbulent Entrainment in Buoyant Jets", Proc. ASCE, J. Hydraulics Division, 99, 1461-1474.
40. List, E. J. (1982), "Mechanics of Turbulent Buoyant Jets and Plumes", Chapter in Turbulent Buoyant Jets and Plumes, (1982). W. Rodi, ed., Pergamon Press.
41. Margason, R. J. (1968), "The Path of a Jet Directed at Large Angles to a Subsonic Stream", N.A.S.A., TN.D.-4919, Langley Research Center, Hampton, Virginia.
42. Monin, A. S. and A. M. Yaglom (1971), Statistical Fluid Mechanics: Mechanics of Turbulence, Vol. 1, MIT Press, Cambridge, Mass, p.485.
43. Morton, B. R., G. I. Taylor, and J. S. Turner (1956), "Turbulent Gravitational Convection from Maintained and Instantaneous Sources", Proceedings Royal Society of London, A234, pp. 1 -23.
44. Morton, R. B. (1959), "Forced Plumes", Journal of Fluid Mechanics, Vol. 5, pp 151-163.
45. Muellenhoff, W. P., et al. (1985), "Initial Mixing Characteristics of Municipal Ocean Discharges (Vol. 1&2)", U.S.E.P.A, Environmental Research Laboratory, Narragansett, R.I.

46. Munk, W. and E. R. Anderson (1948), "Notes on a Theory of the Thermocline." J.Mar. Res. 7, 276-295
47. Naib, S. K. A. (1974), "Deflection of a Submerged Round Jet to Increase Lateral Spreading", La Houille Blanche, Vol. 29, No. 6.
48. National Academy of Science (1968), "Water Quality Criteria (1968)", (Green book), Report of the National Technical Advisory Committee to the Secretary of the Interior, Federal Water Pollution Control Administration, U.S. Dept. of the Interior, Washington, D.C.
49. Ortolano, L. (1984), "Environmental Planning and Decision Making", John Wiley & Sons.
50. Platten, J. L. and J. F. Keffer (1971), "Deflected Turbulent Jet Flows", Transactions of the American Society of Mechanical Engineers, Vol. 38, Dec. 1971, pp. 756-758.
51. Rajaratnam, N. (1976), "Turbulent Jets", Elsevier.
52. Roberts, P. J. W. (1977), "Dispersion of Buoyant Wastewater Discharge From Outfall Diffusers of Finite Length", Report No. KH-R-35, W. M. Keck Laboratory of Hydraulics and Water Resources, Division of Engineering and Applied Sciences, California Institute of Technology, Pasadena, Cal.
53. Roberts, P. J. W. (1979), "Line Plume and Ocean Outfall Dispersion", Journal of the Hydraulics Division, Proc. of the Amer. Soc. of Civil Engineers, Vol. 105, No. HY4, April, pp. 313-331.
54. Rodi, W. ed. (1982), "Turbulent Buoyant Jets and Plumes", Pergamon Press, New York.
55. Scorer, R. S. (1954), "The Behavior of Chimney Plumes", International Journal of Air Pollution, Vol. 1, pp 198-220.
56. Sharp, J. J. and B. D. Vyas, (1977), "The Buoyant Wall Jet", (1977), Proceeding of the Institution of Civil Engineers, Part 2, No. 63, September.
57. Shwartz, J. and M. P. Tulin (1972), "Chimney Plumes in Neutral and Stable Surroundings", Atmospheric Environment, Vol. 6 pp. 19-36.
58. Sobey, R. J., A. J. Johnston, and R. D. Keane (1988), "Horizontal Round Buoyant Jet in Shallow Water", Journal of Hydraulic Engineering, ASCE, Vol. 114, No. 8., August.

59. Tait, H. (1984), "Section 402 Guidelines for Reviewing National Pollutant Discharge Elimination Permits", National Coastal Ecosystems Team, Rept. No. FWS/OBS-84/05, U.S. Dept. of the Interior, Washington, D.C., September.
60. Tennekes, H. and J. L. Lumley (1972), "A First Course in Turbulence", MIT Press, Cambridge, Mass, p. 99.
61. Tong, S. S. and K. D. Stolzenbach (1979), "Submerged Discharges of Dense Effluent", Tech. Rept. 243, Ralph M. Parson Laboratory for Water Resources and Hydrodynamics, Massachusetts Institute of Technology, Cambridge, Massachusetts.
62. USEPA (1972), "Water Quality Criteria 1972", EPA-R3-73-003, Environmental Studies Board, Committee on Water Quality Criteria, Washington, D.C.
63. USEPA (1976), "Quality Criteria for Water 1976" (Red Book), Guidelines for State and Area Wide Water Quality Management Program, Washington, D.C. (Chapter 5).
64. USEPA (1984), "Water Quality Standards Handbook. Office of Water Regulations and Standards, Washington, D.C.
65. USEPA (1984), "Technical Guidance Manual for the Regulations Promulgated Pursuant to Section 301 (a) of the Clean Water Act of 1977 (Draft)", Washington D.C., August.
66. USEPA (1985), "Technical Support Document for Water Quality-based Toxics Control", Office of Water, Washington, D.C., September.
67. Viollet, P.-L. (1977) "Study of Jets in Transverse Currents in Stratified Environments", Doctoral Dissertation, Curie University, Paris, France, February, 1977. (in French)
68. Wright, S. J. (1977), "Effects of Ambient Crossflows and Density Stratification on the Characteristic Behavior of Round Turbulent Buoyant Jets", Rep. KH-R-36, W.M. Keck Laboratory of Hydraulics and Water Resources, California Institute of Technology, Pasadena, Calif.
69. Wong, D. R. (1984), "Buoyant Jet Entrainment in Stratified Fluids", Ph.D. Thesis, Civil Engineering Dept., The University of Michigan, Ann Arbor Mich.

Appendix A

Stability of Stratified Ambient Shear Flows

Within the context of this study there are several possibilities for stratification effects superimposed on the ambient shear flow. The stratification may be present due to existing environmental conditions, or it may be induced by the buoyancy of the effluent discharge (i.e. within the buoyant spreading phase). In either case, a determination can be made as to whether such stratification (i.e. density gradient) can in fact be maintained or whether it will be rapidly eroded by the ambient turbulence.

The flux Richardson number, R_{fc} , is defined as the ratio of the buoyant energy flux to the shear energy production (Tennekes and Lumley, 1972). In terms of the eddy diffusivity convention (Turner, 1973) this can be written as

$$R_f = -gk_H(d\rho/dz)/(\rho k_M(du/dz)^2) \quad (A.1)$$

in which k_M , k_H = eddy diffusivity for momentum and for a scalar (heat), respectively, ρ = local density, and u is the local velocity. A critical value of $R_{fc} \approx 0.10$ to 0.20 has been suggested (Monin and Yaglom, 1971 and Turner, 1973). Above this value, turbulence is damped and a stable stratified profile can be maintained; below this value, turbulence erodes the density profile and the ambient environment will become fully mixed.

Jirka (1980) has proposed an adaptation of Eq. (A.1) for the present shear flow conditions. In the limit of marginally stable conditions, the eddy diffusivities are of the same order, $k_M \approx k_H$ (Reynolds analogy). Hence if ϵ is the existing or the imposed buoyancy gradient, and the velocity gradient is given by the logarithmic law argument, $(du/dz) \approx u_s/(\kappa H_s)$ in which u_s = shear velocity, $\kappa \approx 0.4$ = von Karman constant, and H_s = layer height of the ambient flow. This leads to

$$R_f = \epsilon \kappa^2 H_s^2 / u_s^2 \quad (A.2)$$

With the Darcy-Weisbach friction law, $u_s = (f/8)^{1/2} u_a$, where f = friction factor, the critical value of the buoyancy gradient is derived as

$$\epsilon_c = cf(u_a/H_s)^2 \quad (A.3)$$

where $c = R_{fc}/(8\kappa)^2 \approx 0.02$. If the actual $\varepsilon < \varepsilon_c$ then the stratified shear flow will be unstable and will tend to rapid mixing.

APPENDIX B

CORMIX1 SYSTEM ADVICE

B.1 Introductory Advice

CORNELL MIXING ZONE EXPERT SYSTEM: GENERAL INFORMATION

The Cornell Mixing Zone Expert System (CORMIX) is a series of software subsystems for the analysis, prediction and design of aqueous discharges into watercourses, with emphasis on the geometry and dilution characteristics of the initial mixing zone. Subsystem CORMIX1 deals with buoyant submerged single port discharges into flowing unstratified or stratified water environments, such as rivers, lake, estuaries, and coastal waters. It includes the limiting cases of non-buoyant and negatively buoyant discharges and of stagnant ambient conditions. Please note that the time for loading of individual program elements will depend on the speed of your computer and the size of the program element. The time for these file operations may range from a few seconds (IBM PS/2 Model 70, 80386-based) to more than a minute (IBM PC/XT, 8088-based). Also DOS file manipulation information is displayed by the system during program execution and may be neglected by the user.

PROGRAM ELEMENTS: The program elements of CORMIX1 are listed below. During system use the program elements are loaded sequentially and automatically in the order given below.

1) **DATIN** This is a knowledge base program for the entry of relevant data about the discharge situation and for the initialization of the other program elements. DATIN consist of four subprograms that execute automatically; each subprogram assembles a data group. You are presently using DATIN. The four data groups DATIN seeks are: general identifier information, ambient conditions (geometry and hydrography), discharge conditions (geometry and fluxes), and output information desired including legal mixing zone definitions. After each subprogram executes, the values for data entered or concluded are displayed. DATIN is a detailed program with complete explanations on data preparations, assumptions and schematizations. DATIN along with the programs PARAM and CLASS (described below) automatically creates the files fn.CXD, and HYDRO.CXE where fn is a user supplied file name. The fn.CXD contains all

necessary input data for the hydrodynamic simulation model HYDRO described below. The HYDRO.CXE file instructs HYDRO which fn.CXD file to load as input for the current session.

2) PARAM This is a knowledge base program that computes the relevant physical parameters for the given discharge situation. Output from PARAM is included in the fn.CXD file.

3) CLASS This is a knowledge base program that classifies the given discharge into one of many possible hydrodynamic configurations, e.g. a boundary attached discharge, an unstable vertically mixed case, or mixing controlled by the ambient crossflow. Each separate flow configuration has a unique alphanumeric label (Example V1,S5,..). A detailed hydrodynamic description for each flow configuration is available. Output from CLASS is contained in the fn.CXD file.

4) HYDRO This is a knowledge base program that executes the external FORTRAN hydrodynamic program consisting of a number of simulations subroutines (modules) each corresponding to a particular hydrodynamic mixing process. For each flow configuration (Examples: V1, S5) identified in CLASS, the appropriate modules are executed sequentially according to a specific protocol. The program outputs data on geometry (trajectory, width, etc.) and associated mixing (dilution, concentration) following the path of the effluent discharge. CLASS automatically creates the files fn.CXO and fn.CXS where fn is the user supplied file name. The fn.CXO contains the output file data for the HYDRO. The fn.CXS file is used as input by the final program segment SUM.

5) SUM This is a knowledge base program that summarizes the given situation, comments on the mixing characteristics, evaluates how applicable legal requirements are satisfied, and suggests possible design alternatives and improvements.

UNITS OF MEASUREMENT: CORMIX uses the SI system of measurement, specifically: length in m, mass in kg, time in s, and temperature in deg C. Furthermore, all pollutant concentrations are considered without units, i.e. the user can specify these in any units he/she desires and all output data must be interpreted accordingly in these same units.

COORDINATE SYSTEM: All predictions in CORMIX1 are displayed using the following three-dimensional coordinate system:
-The origin is located at the bottom of the water body vertically below the center of the discharge port.

- The x-axis is located at the bottom and directed in the downstream direction following the ambient flow.
- The y-axis is located at the bottom and points to the left normal to the ambient flow direction (x-axis).
- The z-axis points vertically upward.

B.2 Ambient advice

DATA REQUIREMENTS FOR AMBIENT CONDITIONS: Ambient conditions are defined by the hydrographic and the geometric conditions in the vicinity of the discharge. For this purpose typical cross-sections normal to the ambient flow direction at the discharge site and further downstream need to be considered:

A) Bounded cross-section: If the cross-section is bounded on both sides by banks - as in rivers, streams, narrow estuaries, and other narrow watercourses -, then the cross-section is considered "bounded".

B) Unbounded cross-section: In some cases the discharge is located close to one boundary while the other boundary is for practical purposes very far away. This would include discharges into wide lakes, estuaries and coastal areas. These situations are defined as "unbounded".

A) **BOUNDED CROSS-SECTION:** Hydrographic information: Data on the design ambient flow condition - such as average river discharge or low flow discharge - needs to be available. The user has the option of entering such data directly as the discharge or as an average velocity. The ambient density profile (i.e. the vertical distribution of the ambient water density) must be approximated. It may be specified as either uniform (within given limits) or approximated as one of four simplified profiles. An opportunity for obtaining more detailed information on these profiles is given later. The ambient density can be specified directly, or -in case of freshwater- is computed after specification of the ambient temperature. Geometric information: CORMIX will conduct its analysis assuming a rectangular cross-section that is given by a width and a depth both of which are constant in the downstream direction following the ambient flow. This schematization may be quite evident for well-channeled and regular rivers or artificial channels. For highly irregular cross-sections, it may require more judgement and experience - perhaps combined with a repeated use of CORMIX to get a better feeling on the sensitivity of the results. In any case, the user is advised to consider the following steps:

1) Be aware that a particular flow condition (such as a river discharge) is usually associated with a certain water surface elevation ("stage"). Data for a stage-discharge

relationship is normally available from a separate hydraulic analysis or from field measurements.

2) For the given stage-discharge combination display the cross-section at the discharge location and several downstream cross-sections. Look over these. Determine an "equivalent rectangular cross-sectional area". Very shallow bank areas or shallow floodways may be neglected. Also more weight should be given to the cross-sections at, and close to, the discharge location.

3) Determine the surface width and depth of the equivalent rectangular area. In case that ambient discharge and ambient velocity data are available, note that the continuity relation specifies that $discharge = (velocity * cross-sectional\ area)$. The width and depth values thus chosen need to be specified to CORMIX which will check for any inconsistencies. Note On Stagnant Conditions: If zero (or a very small value) for ambient velocity is entered, CORMIX will label the discharge environment as stagnant. In this case CORMIX will predict only the near field of the discharge. Although stagnant conditions represent an extreme limiting case for dilution prediction, a more realistic assumption for natural water bodies would be to consider a finite ambient crossflow, no matter how small. It is therefore recommended to conduct subsequent analysis with a small crossflow.

4) As a measure of geometric non-uniformity also specify the actual maximum depth of the cross-sections (again with more weight given to the near-discharge cross-sections).

5) As a measure of the roughness characteristics in the channel the value of the Manning "n", or alternatively of the Darcy-Weisbach friction factor "f", must be specified. These parameters influence the mixing process only in the final stage considered by CORMIX and are not very sensitive to the predictions. Generally, if these values are assumed known within $\pm 30\%$ the predictions will vary by $\pm 10\%$ at the most.

B) UNBOUNDED CROSS-SECTIONS: Both hydrographic and geometric information are closely linked in this case:

1) Determine the water elevation (given by lake or reservoir elevation or tidal stage etc.) for which the analysis should be conducted.

2) Assemble cross-sectional profiles that plot water depth as a function of distance from the shore for the discharge location and for several positions downstream following the ambient current direction.

3) a) If detailed hydrographic data (from field surveys or from some hydraulic numerical model calculations) are available, determine the cumulative ambient discharge from the shore to the discharge location for the discharge cross-section. For each of the subsequent downstream cross-sections determine the distance from the shore at which the same cumulative ambient discharge has been attained. Mark this position on all cross-sectional profiles. Now consider the velocity (vertically averaged) and the depth at these positions. Specify to CORMIX a typical ambient velocity and a typical depth from these data by giving most weight to the conditions at, and close to, the discharge location. Specify a typical distance from the shore by dividing the cumulative ambient discharge by (ambient velocity * depth).

3b) If detailed hydrographic data is not available - but at least data, or estimates, on the vertically averaged velocity at the discharge location must be available! - then determine the cumulative cross-sectional area from the shore to the discharge location for the discharge cross-section. For each of the subsequent downstream cross-sections, mark the position where the cumulative cross-sectional area has the same value as at the discharge cross-section. Determine the typical ambient velocity and the typical ambient depth at these positions with most weight given to conditions at, or close to, the discharge location. Specify the typical distance from the shore by dividing the cumulative cross-sectional area by the ambient depth.

4) In summary, CORMIX will conduct its analysis for the unbounded case by assuming an "equivalent rectangular cross-sectional area" defined by depth, by distance from one bank to the discharge position, and by ambient velocity. Note the similarities to the bounded case discussed above. As for the bounded cross-section, the ambient density profile (i.e. the vertical distribution of the ambient water density) must be approximated. It may be specified as either uniform (within given limits) or approximated as one of four simplified profiles. An opportunity for obtaining more detailed information on these profiles is given later. The ambient density can be specified directly, or -in case of a freshwater ambient - is computed by specification of the ambient temperature.

5) As a measure of the roughness characteristics of the flow area the value of the Manning "n", or alternatively of the Darcy-Weisbach friction factor "f", must be specified. These parameters influence the mixing process only in the final stage considered by CORMIX and are not very sensitive to the predictions. Generally, if these values are assumed

known within $\pm 30\%$ the predictions will vary by $\pm 10\%$ at the most.

B.3 Density Profile Advice

SPECIFICATION OF AMBIENT DENSITY STRATIFICATION:

Since the ambient density is not uniform over the water column, the actual vertical density distribution - as determined by field data - must be approximated by one of the schematic stratification types. These are:

Type A: Linear Density Profile

Type B: Two-Layer System With Constant Densities and Density Jump

Type C: Constant Density Surface Layer with Linear Density Profile in Bottom Layer Separated by a Density Jump

Type D: Constant Density Surface Layer With Linear Density Profile in Bottom Layer Without a Density Jump

Brief sketches for these four stratification types follow below. Note that a dynamically correct approximation of the actual distribution should keep a balance between over - and under - estimation of the actual data similar to a best-fit in regression analysis. It is desirable to test through repeated use of CORMIX different approximations (i.e. with different stratification types and/or parameter values) in order to evaluate the sensitivity of the resulting model predictions.

B.4 Discharge Advice

ADVICE FOR SPECIFYING DISCHARGE CHARACTERISTICS SINGLE PORT DISCHARGE DISCHARGE GEOMETRY:

- 1) In most cases, the port or nozzle geometry will be round so that the radius or diameter must be specified. If not, then the cross-sectional area must be specified.
- 2) Specify the height of the port center above the bottom.
- 3) The vertical angle of discharge is the angle between the port centerline and a horizontal plane. In CORMIX1 this angle may range between -45 deg and 90.0 deg. As examples, the vertical angle is 90 deg for a discharge pointing vertically upward, and it is 0 deg for a horizontal discharge.

4) Consider a plan view of the discharge situation as seen from above. The horizontal angle of discharge is the angle measured counterclockwise from the ambient current direction (x-axis) to the plan projection of the port centerline. In CORMIX1 this angle may range between 0 deg and 360 deg. As examples, the horizontal angle is 0 deg if the port points downstream with the ambient flow, it is 90 deg if it points to the left of the ambient flow, it is 180 deg if it points upstream opposing the ambient flow, and it is 270 deg if it points to the right of the ambient flow, respectively.

DISCHARGE FLOW VARIABLES:

- 1) The discharge flow rate or the discharge velocity should be specified. Note that these two variables are related through the port diameter or cross-sectional area.
- 2) The discharge density can be specified directly, or -in case of an essentially freshwater discharge in which the addition of any pollutant or tracer has negligible effect on density - it is computed after specification of the discharge temperature.
- 3) The discharge concentration of the material of interest (pollutant, tracer, or temperature) is defined as the excess concentration above any ambient concentration. The user can specify this quantity in any units and the CORMIX1 results for computed excess concentrations should then be interpreted in these same units.

B.5 Mixing Zone Advice

SPECIFICATION OF DESIRED MIXING ZONE INFORMATION:

The user must specify data that indicates over which spatial region information will be desired, and in what detail. Legal mixing zone (LMZ) requirements may exist or not. The user has several options for this specification:

- 1) LEGAL MIXING ZONE (LMZ): Options exist for specifying the legal mixing zone as a maximum distance from the discharge location, or as a maximum cross-sectional area occupied by the plume, or as the maximum width of the effluent plume.
- 2) REGION OF INTEREST (ROI): When legal mixing zone restrictions do not exist or when the user is interested in information over a larger area, then a region of interest must be specified as the maximum distance in the direction of mixed effluent flow.
- 3) HYDRODYNAMIC MIXING ZONE (HMZ): In all cases, CORMIX will label a usually smaller initial region in which discharge-induced mixing takes place as the "hydrodynamic

mixing zone". The dilution conditions in the HMZ may be a useful measure for the outfall designer when attempting to optimally design the discharge conditions.

4) TOXIC DILUTION ZONE (TDZ): For all discharges that have been designated as toxic by USEPA standards (Technical Support Document for Water Quality- Based Toxics Control, USEPA, 1985) CORMIX will automatically define the concentration values at the edge of the toxic dilution zone as defined in that document. CORMIX will indicate if the criterion maximum concentration (CMC) standard has been met. After all applicable data have been specified on these zones, CORMIX also needs information on the level of detail for the output data within these zones and, simultaneously, within all the hydrodynamic elements (modules) that may occupy these zones.

B.6 Design Advice

A reliable environmental analysis and mixing zone prediction is possible only if each design case is evaluated through several iterations of CORMIX1. Small changes in ambient or discharge design conditions can sometimes cause drastic shifts in the applicable flow configuration (flow class) and the size or appearance of mixing zones. Iterative use of CORMIX1 will give information on the sensitivity of predicted results on design and ambient conditions. Each predictive case should be carefully assessed as to: - size and shape of LMZ - conditions in the TDZ (if present) - bottom impact of the discharge flow - water surface exposure - bank attachment, and other factors. In general, iteration should be conducted in the following order:

- A) Discharge design changes (geometry variations)
- B) Sensitivity to ambient conditions
- C) Discharge flow changes (process variations)

When investigating these variations the CORMIX1 user will quickly appreciate the fact that mixing conditions at short distances (near-field) are usually quite sensitive and controllable. In contrast, mixing conditions at large distances (far-field) often show little sensitivity unless the ambient conditions change substantially or drastic process variations are introduced.

A) DISCHARGE DESIGN CHANGES (GEOMETRY VARIATIONS): Most of the following recommendations are motivated by the desire of improving conditions in the applicable mixing zones (i.e. minimizing concentrations and/or areal extent).

- 1) Outfall location: Consider moving the discharge farther offshore to a larger water depth in order to delay flow interaction with the bank and/or surface, and to improve near-field mixing.
- 2) Height of discharge port: For positively buoyant or neutral discharges it is usually desirable to minimize the port height in order to provide a low submerged jet/plume trajectory. However, if the port height is too small undesirable flow bottom attachment may result. A typical range for port heights is from two to ten diameters. For negatively buoyant discharges, on the other hand, it may be desirable to maximize the port height. Navigational requirements may put further limits on large port heights.
- 3) Vertical angle of discharge: Near-field dilution for positively or neutrally buoyant discharges is often improved by providing a near-horizontal discharge. In order to prevent bottom interference a slight upward orientation (in the range of +15 to +30 degrees) may be advisable. In contrast, a vertical or near-vertical angle may be favorable for negatively buoyant discharges.
- 4) Horizontal angle of discharge: This angle provides the discharge orientation relative to the ambient current. A co-flow design (angle of about 0 degrees) or a cross-flow design (about 90 or 270 degrees, respectively) are preferable. A counter-flow design (about 180 degrees) is undesirable from the viewpoint of mixing zone predictability and bottom impacts. Cross-flow designs may be particularly effective in optimizing near-field mixing, and if they are chosen, the port should point in the offshore direction.
- 5) Port diameter/area (discharge velocity): Remember that for a given discharge flow rate the port area and discharge velocity are inversely related: a small discharge port implies a high discharge velocity, and a consequently high discharge momentum flux. Typically, a high velocity discharge will maximize near-field mixing. Note, however, that high velocity discharges a) may lead to unstable near-field flow configurations perhaps involving undesirable mixing patterns, and b) usually have little, if any, effect on dilutions over the far-field where a LMZ may apply. Discharge velocities in typical engineering designs may range from 3 m/s to 8 m/s. Very high velocities may lead to excessive pumping energy requirements. Very low velocities (less than 0.5 m/s) may lead to undesirable sediment accumulation within the discharge pipe.

B) SENSITIVITY TO AMBIENT CONDITIONS: Variations - of the order of 10 percent - of the following ambient design conditions should be considered: - ambient velocity (or ambient flowrate) - ambient depth (or river/tidal stage) - ambient density structure (notably density differences) Such variability is important for two reasons:

- 1) the usual uncertainty in ambient environmental data,
- 2) the schematization employed by CORMIX1. Please refer to the detailed advice on the specification of environmental data, including the density structure, that is available in program element DATIN. In particular, note the advisory comments on stagnant ambient conditions.

C) DISCHARGE FLOW CHANGES (PROCESS VARIATIONS): Actual process changes can result in variations of one or more of three parameters associated with the discharge: flowrate, density, or pollutant concentration. In some cases, such process changes may be difficult to achieve or too costly. Note, that "off-design" conditions in which a discharge operates below its full capacity also fall into this category.

- 1) Pollutant mass flux: The total pollutant mass flux is the product of discharge flow (m^3/s) times the discharge pollutant concentration (in arbitrary units). Thus, decreasing the pollutant mass flux will, in general, decrease the resulting pollutant concentration in the near-field and far-field. This occurs, of course, during off-design conditions.
- 2) Discharge flow: For a given pollutant mass flux, an increase in discharge flow implies an increase in discharge pollutant concentration, and vice versa. For the variety of flow classes contained in CORMIX1 there is no universal rule whether high or low volume discharges are preferable for optimizing near-field mixing. Mostly, the sensitivity is small, and even more so for far-field effects. Note that a change in discharge flow will influence in turn the discharge velocity and hence momentum flux.
- 3) Discharge density: The actual density of the discharge flow controls the buoyancy effects relative to the ambient water. Occasionally, the discharge density is controllable through the amount of process heating or cooling occurring prior to discharge. Usually, near-field mixing is enhanced by maximizing the total density difference (positive or negative) between discharge flow and ambient water. In most cases, however, this effect is minor.

APPENDIX C

Flow Classification Descriptions

C.1 V-Flow Classes

FLOW CLASS V1

A submerged buoyant effluent issues vertically or near-vertically from the discharge port.

The discharge configuration is hydrodynamically "stable", that is the discharge strength (measured by its momentum flux) is weak in relation to the layer depth and in relation to the stabilizing effect of the discharge buoyancy (measured by its buoyancy flux).

The following flow zones exist:

1) Momentum-dominated near-field jet: The flow is initially dominated by the effluent momentum (jet-like) and is weakly deflected by the ambient current.

2) Buoyancy-dominated near-field plume: After some distance the discharge buoyancy becomes the dominating factor (plume-like). The plume deflection by the ambient current is still weak.

Alternate possibility: Depending on the ratio of the jet to crossflow length scale to the plume to crossflow length scale the above zone may be replaced by a momentum-dominated far-field jet:

2) Momentum-dominated far-field jet: The jet has become strongly deflected by the ambient current.

3) Buoyancy-dominated far-field plume: The plume has been strongly deflected by the current and is slowly rising toward the surface.

4) Layer boundary approach: The bent-over submerged jet/plume approaches the layer boundary (water surface or pycnocline). Within a short distance the concentration distribution becomes relatively uniform across the plume width and thickness.

*** The zones listed above constitute the HYDRODYNAMIC MIXING ZONE in which strong initial mixing takes place.***

5) Buoyant spreading at layer boundary: The plume spreads laterally along the layer boundary (surface or pycnocline) while it is being advected by the ambient current. The plume thickness may decrease during this phase. The mixing rate is relatively small. The plume may interact with a nearby bank or shoreline.

6) Passive ambient mixing: After some distance the background turbulence in the ambient shear flow becomes the dominating mixing mechanism. The passive plume is growing in depth and in width. The plume may interact with the channel bottom and/or banks.

*** Predictions will be terminated in zone 5 or 6 depending on the definitions of the LEGAL MIXING ZONE or the REGION OF INTEREST. ***

FLOW CLASS V2

A submerged buoyant effluent issues vertically or near-vertically from the discharge port. The discharge configuration is hydrodynamically "stable", that is the discharge strength (measured by its momentum flux) is weak in relation to the layer depth. The discharge buoyancy plays a minor role in this case. The following flow zones exist:

1) Momentum-dominated near-field jet: The flow is initially dominated by the effluent momentum (jet-like) and is weakly deflected by the ambient current.

2) Momentum-dominated far-field jet: The jet has become strongly deflected by the ambient current and is slowly rising toward the surface.

3) Layer boundary approach: The bent-over submerged jet/plume approaches the layer boundary (water surface or pycnocline). Within a short distance the concentration distribution becomes relatively uniform across the plume width and thickness.

*** The zones listed above constitute the HYDRODYNAMIC MIXING ZONE in which strong initial mixing takes place.***

4) Buoyant spreading at layer boundary: The plume spreads laterally along the layer boundary (surface or pycnocline) while it is being advected by the ambient current. The plume thickness may decrease during this phase. The mixing rate is relatively small. The plume may interact with a nearby bank or shoreline.

5) Passive ambient mixing: After some distance the background turbulence in the ambient shear flow becomes the dominating mixing mechanism. The passive plume is growing in depth and in width. The plume may interact with the channel bottom and/or banks.

*** Predictions will be terminated in zone 4 or 5 depending on the definitions of the LEGAL MIXING ZONE or the REGION OF INTEREST.***

SPECIAL CASE: If discharge is non-buoyant, then the layer boundary buoyant spreading regime (zone 4) is absent.

FLOW CLASS V3

A submerged buoyant effluent issues vertically or near-vertically from the discharge port. The discharge configuration is hydrodynamically "stable", that is the discharge strength (measured by its momentum flux) is weak in relation to the layer depth and in relation to the stabilizing effect of the discharge buoyancy (measured by its buoyancy flux). The buoyancy effect is very strong in the present case. The following flow zones exist:

1) Momentum-dominated near-field jet: The flow is initially dominated by the effluent momentum (jet-like) and is weakly deflected by the ambient current.

2) Buoyancy-dominated near-field plume: After some distance the discharge buoyancy becomes the dominating factor (plume-like). The plume deflection by the ambient current is still weak.

3) Layer boundary impingement/upstream spreading: The weakly bent jet/plume impinges on the layer boundary (water surface or pycnocline) at a near-vertical angle. After impingement the flow spreads more or less radially along the layer boundary. In particular, the flow spreads some distance upstream against the ambient flow, and laterally across the ambient flow. This spreading is dominated by the strong buoyancy of the discharge.

*** The zones listed above constitute the HYDRODYNAMIC MIXING ZONE in which strong initial mixing takes place. ***

4) Buoyant spreading at layer boundary: The plume spreads laterally along the layer boundary (surface or pycnocline) while it is being advected by the ambient current. The plume thickness may decrease during this phase. The mixing rate is relatively small. The plume may interact with a nearby bank or shoreline.

5) Passive ambient mixing: After some distance the background turbulence in the ambient shear flow becomes the dominating mixing mechanism. The passive plume is growing in depth and in width. The plume may interact with the channel bottom and/or banks.

*** Predictions will be terminated in zone 4 or 5 depending on the definitions of the LEGAL MIXING ZONE or the REGION OF INTEREST. ***

FLOW CLASS V4

A submerged buoyant effluent issues vertically or near-vertically from the discharge opening. The discharge configuration is hydrodynamically "unstable", that is the discharge strength (measured by its momentum flux) dominates the flow in relation to the limited layer depth. The role of buoyancy is secondary. The following flow zones exist:

1) Momentum-dominated near-field jet: The flow is dominated by the effluent momentum (jet-like) and is weakly deflected by the ambient current.

2) Layer boundary impingement/full vertical mixing: The weakly bent jet impinges on the layer boundary (water surface or pycnocline) at a near-vertical angle. Given the shallow layer depth and the weak buoyancy of the discharge, the flow becomes unstable after impingement. This results in a recirculating region immediately downstream that extends over the full layer depth.

3) Passive ambient mixing: The vertically fully mixed plume is further advected by the ambient flow and spreads laterally through ambient diffusion. The plume may interact with a nearby bank or shoreline.

***The ambient flow plays an important role in this flow configuration. Hence, all the zones listed above constitute the HYDRODYNAMIC MIXING ZONE with strong initial mixing. Predictions will be terminated in zone 3 depending on the definitions of the LEGAL MIXING ZONE or the REGION OF INTEREST. ***

FLOW CLASS V5

A submerged buoyant effluent issues vertically or near-vertically from the discharge port. The discharge configuration is hydrodynamically "stable", that is the discharge strength (measured by its momentum flux) is weak in relation to the layer depth and in relation to the stabilizing effect of the discharge buoyancy (measured by

its buoyancy flux). The buoyancy effect is very strong in the present case. The following flow zones exist:

1) Momentum-dominated near-field jet: The flow is initially dominated by the effluent momentum (jet-like) and is weakly deflected by the ambient current.

2) Buoyancy-dominated near-field plume: After some distance the discharge buoyancy becomes the dominating factor (plume-like). The plume deflection by the ambient current is still weak.

3) Layer boundary impingement/upstream spreading: The weakly bent jet/plume impinges on the layer boundary (water surface or pycnocline) at a near-vertical angle. After impingement the flow spreads more or less radially along the layer boundary. In particular, the flow spreads some distance upstream against the ambient flow, and laterally across the ambient flow. This spreading is dominated by the strong buoyancy of the discharge.

*** The zones listed above constitute the HYDRODYNAMIC MIXING ZONE in which strong initial mixing takes place.***

4) Buoyant spreading at layer boundary: The plume spreads laterally along the layer boundary (surface or pycnocline) while it is being advected by the ambient current. The plume thickness may decrease during this phase. The mixing rate is relatively small. The plume may interact with a nearby bank or shoreline.

5) Passive ambient mixing: After some distance the background turbulence in the ambient shear flow becomes the dominating mixing mechanism. The passive plume is growing in depth and in width. The plume may interact with the channel bottom and/or banks.

*** Predictions will be terminated in zone 4 or 5 depending on the definitions of the LEGAL MIXING ZONE or the REGION OF INTEREST.***

SPECIAL CASE: If the ambient is stagnant, then advection and diffusion by the ambient flow (zones 4 and 5) cannot be considered. The mixing is limited to the hydrodynamic mixing zone (zones 1 to 3) and the predictions will be terminated at this stage. Such stagnant water predictions may be a useful initial mixing indicator for a given site and discharge design. For practical final predictions, however, the advection and diffusion of the ambient flow - no matter how small in magnitude - should be considered.

FLOW CLASS V6

A submerged buoyant effluent issues vertically or near-vertically from the discharge port. The discharge configuration is hydrodynamically "unstable", that is the discharge strength (measured by its momentum flux) dominates the flow in relation to the limited layer depth and in relation to the weak stabilizing effect of the discharge buoyancy (measured by its buoyancy flux). However, the buoyancy is generally strong enough to affect the flow at larger distances downstream from the unstable initial region. The following flow zones exist:

1) Unstable recirculation/buoyant restratification/upstream spreading: The buoyant jet rises near-vertically and impinges on the layer boundary (water surface or pycnocline). After impingement the mixed flow recirculates over the limited layer depth and becomes partially re-entrained into the discharge jet. The degree of recirculation - and hence the overall mixing in this region - is controlled by restratification of the flow at the edge of this recirculating region. The restratified flow spreads along the layer boundary. In particular, the flow spreads some distance upstream against the ambient current, and laterally across the ambient flow.

*** The region described above constitutes the HYDRODYNAMIC MIXING ZONE in which strong initial mixing takes place.***

2) Buoyant spreading at layer boundary: The plume spreads laterally along the layer boundary (surface or pycnocline) while it is being advected by the ambient current. The plume thickness may decrease during this phase. The mixing rate is relatively small. The plume may interact with a nearby bank or shoreline.

3) Passive ambient mixing: After some distance the background turbulence in the ambient shear flow becomes the dominating mixing mechanism. The passive plume is growing in depth and in width. The plume may interact with the channel bottom and/or banks.

*** Predictions will be terminated in zone 2 or 3 depending on the definitions of the LEGAL MIXING ZONE or the REGION OF INTEREST.***

SPECIAL CASE: If the ambient is stagnant, so that advection and diffusion by the ambient flow (zones 2 and 3) cannot be considered. The mixing is limited to the hydrodynamic mixing zone (zone 1) and the predictions will be terminated at this stage. Such stagnant water predictions may be a useful initial mixing indicator for a given site and discharge design. For practical final predictions, however, the

advection and diffusion of the ambient flow - no matter how small in magnitude - should be considered.

SPECIAL SPECIAL CASE: If, in addition, the discharge is non-buoyant, then no steady-state behavior is possible in this case. The repeated recirculation in the near-field will lead to an unsteady concentration build-up. This would be an **UNDESIRABLE** discharge design, and no reliable predictive techniques exist for this situation.

CORMIX1 WILL NOT PROVIDE A DETAILED PREDICTION FOR THIS CASE.

C.2 H-Flow Classes

FLOW CLASS H1

A submerged buoyant effluent issues horizontally or near-horizontally from the discharge port. The discharge configuration is hydrodynamically "stable", that is the discharge strength (measured by its momentum flux) is weak in relation to the layer depth and in relation to the stabilizing effect of the discharge buoyancy (measured by its buoyancy flux). The following flow zones exist:

- 1) Momentum-dominated near-field jet: The flow is initially dominated by the effluent momentum (jet-like) and is weakly deflected by the ambient current.
- 2) Buoyancy-dominated near-field plume: After some distance the discharge buoyancy becomes the dominating factor (plume-like). The plume deflection by the ambient current is still weak. Alternate possibility: Depending on the ratio of the jet to crossflow length scale to the plume to crossflow length scale the above zone may be replaced by a momentum-dominated far-field jet:
- 2) Momentum-dominated far-field jet: The jet has become strongly deflected by the ambient current.
- 3) Buoyancy-dominated far-field plume: The plume has been strongly deflected by the current and is slowly rising.
- 4) Layer boundary approach: The bent-over submerged jet/plume approaches the layer boundary (water surface or pycnocline). Within a short distance the concentration distribution becomes relatively uniform across the plume width and thickness.

***** The zones listed above constitute the HYDRODYNAMIC MIXING ZONE in which strong initial mixing takes place.*****

5) Buoyant spreading at layer boundary: The plume spreads laterally along the layer boundary (surface or pycnocline) while it is being advected by the ambient current. The plume thickness may decrease during this phase. The mixing rate is relatively small. The plume may interact with a nearby bank or shoreline.

6) Passive ambient mixing: After some distance the background turbulence in the ambient shear flow becomes the dominating mixing mechanism. The passive plume is growing in depth and in width. The plume may interact with the channel bottom and/or banks.

*** Predictions will be terminated in zone 5 or 6 depending on the definitions of the LEGAL MIXING ZONE or the REGION OF INTEREST. ***

FLOW CLASS H2

A submerged buoyant effluent issues horizontally or near-horizontally from the discharge point. The discharge configuration is hydrodynamically "stable", that is the discharge strength (measured by its momentum flux) is weak in relation to the layer depth. The discharge buoyancy plays a minor role in this case. The following flow zones exist:

1) Momentum-dominated near-field jet: The flow is initially dominated by the effluent momentum (jet-like) and is weakly deflected by the ambient current.

2) Momentum-dominated far-field jet: The jet has become strongly deflected by the ambient current and is slowly rising.

3) Layer boundary approach: The bent-over submerged jet/plume approaches the layer boundary (water surface or pycnocline). Within a short distance the concentration distribution becomes relatively uniform across the plume width and thickness.

*** The zones listed above constitute the HYDRODYNAMIC MIXING ZONE in which strong initial mixing takes place. ***

4) Buoyant spreading at layer boundary: The plume spreads laterally along the layer boundary (surface or pycnocline) while it is being advected by the ambient current. The plume thickness may decrease during this phase. The mixing rate is relatively small. The plume may interact with a nearby bank or shoreline.

5) Passive ambient mixing: After some distance the background turbulence in the ambient shear flow becomes the dominating mixing mechanism. The passive plume is growing in depth and in width. The plume may interact with the channel bottom and/or banks.

*** Predictions will be terminated in zone 4 or 5 depending on the definitions of the LEGAL MIXING ZONE or the REGION OF INTEREST. ***

SPECIAL CASE: If discharge is non-buoyant, then the layer boundary buoyant spreading regime (zone 4) is absent.

FLOW CLASS H3

A submerged buoyant effluent issues horizontally or near-horizontally from the discharge port. The discharge configuration is hydrodynamically "stable", that is the discharge strength (measured by its momentum flux) is weak in relation to the layer depth and in relation to the stabilizing effect of the discharge buoyancy (measured by its buoyancy flux). The buoyancy effect is very strong in the present case. The following flow zones exist:

1) Momentum-dominated near-field jet: The flow is initially dominated by the effluent momentum (jet-like) and is weakly deflected by the ambient current.

2) Buoyancy-dominated near-field plume: After some distance the discharge buoyancy becomes the dominating factor (plume-like). The plume deflection by the ambient current is still weak.

3) Layer boundary impingement/upstream spreading: The weakly bent jet/plume impinges on the layer boundary (water surface or pycnocline) at a near-vertical angle. After impingement the flow spreads more or less radially along the layer boundary. In particular, the flow spreads some distance upstream against the ambient flow, and laterally across the ambient flow. This spreading is dominated by the strong buoyancy of the discharge.

*** The zones listed above constitute the HYDRODYNAMIC MIXING ZONE in which strong initial mixing takes place.***

4) Buoyant spreading at layer boundary: The plume spreads laterally along the layer boundary (surface or pycnocline) while it is being advected by the ambient current. The plume thickness may decrease during this phase. The mixing rate is relatively small. The plume may interact with a nearby bank or shoreline.

5) Passive ambient mixing: After some distance the background turbulence in the ambient shear flow becomes the dominating mixing mechanism. The passive plume is growing in depth and in width. The plume may interact with the channel bottom and/or banks.

*** Predictions will be terminated in zone 4 or 5 depending on the definitions of the LEGAL MIXING ZONE or the REGION OF INTEREST. ***

FLOW CLASS H4-0

A submerged buoyant effluent issues horizontally or near-horizontally from the discharge port. The discharge is co-flowing or nearly co-flowing with the ambient current. The discharge configuration is hydrodynamically "stable", that is the discharge strength (measured by its momentum flux) is weak in relation to the layer depth and in relation to the stabilizing effect of the discharge buoyancy (measured by its buoyancy flux). The buoyancy effect is very strong in the present case. This discharge configuration is very susceptible to attachment of the jet/plume to the bottom of the receiving water. The following flow zones exist:

1) Momentum-dominated near-field jet: The flow is initially dominated by the effluent momentum (jet-like) and is weakly advected by the ambient current.

2) Buoyancy-dominated near-field plume: After a short distance the discharge buoyancy becomes the dominating factor (plume-like). The plume rises upward while the advection by the ambient current is still weak.

3) Layer boundary impingement/upstream spreading: The weakly bent jet/plume impinges on the layer boundary (water surface or pycnocline) at a near-vertical angle. After impingement the flow spreads more or less radially along the layer boundary. In particular, the flow spreads some distance upstream against the ambient flow, and laterally across the ambient flow. This spreading is dominated by the strong buoyancy of the discharge.

*** The zones listed above constitute the HYDRODYNAMIC MIXING ZONE in which strong initial mixing takes place.***

4) Buoyant spreading at layer boundary: The plume spreads laterally along the layer boundary (surface or pycnocline) while it is being advected by the ambient current. The plume thickness may decrease during this phase. The mixing rate is relatively small. The plume may interact with a nearby bank or shoreline.

5) **Passive ambient mixing:** After some distance the background turbulence in the ambient shear flow becomes the dominating mixing mechanism. The passive plume is growing in depth and in width. The plume may interact with the channel bottom and/or banks.

*** Predictions will be terminated in zone 4 or 5 depending on the definitions of the LEGAL MIXING ZONE or the REGION OF INTEREST. ***

SPECIAL CASE: If the ambient is stagnant, then advection and diffusion by the ambient flow (zones 4 and 5) cannot be considered. The mixing is limited to the hydrodynamic mixing zone (zones 1 to 3) and the predictions will be terminated at this stage. Such stagnant water predictions may be a useful initial mixing indicator for a given site and discharge design. For practical final predictions, however, the advection and diffusion of the ambient flow - no matter how small in magnitude - should be considered.

FLOW CLASS H4-90

A submerged buoyant effluent issues horizontally or near-horizontally from the discharge port. The discharge is at, or approximately at, a right angle with the ambient current. The discharge configuration is hydrodynamically "stable", that is the discharge strength (measured by its momentum flux) is weak in relation to the layer depth and in relation to the stabilizing effect of the discharge buoyancy (measured by its buoyancy flux). The buoyancy effect is very strong in the present case. This discharge configuration is very susceptible to attachment of the jet/plume to the bottom of the receiving water. The following flow zones exist:

1) **Momentum-dominated near-field jet:** The flow is initially dominated by the effluent momentum (jet-like) and is weakly advected by the ambient current.

2) **Buoyancy-dominated near-field plume:** After a short distance the discharge buoyancy becomes the dominating factor (plume-like). The plume rises upward while the advection by the ambient current is still weak.

3) **Layer boundary impingement/upstream spreading:** The weakly bent jet/plume impinges on the layer boundary (water surface or pycnocline) at a near-vertical angle. After impingement the flow spreads more or less radially along the layer boundary. In particular, the flow spreads some distance upstream against the ambient flow, and laterally across the

ambient flow. This spreading is dominated by the strong buoyancy of the discharge.

*** The zones listed above constitute the HYDRODYNAMIC MIXING ZONE in which strong initial mixing takes place.***

4) Buoyant spreading at layer boundary: The plume spreads laterally along the layer boundary (surface or pycnocline) while it is being advected by the ambient current. The plume thickness may decrease during this phase. The mixing rate is relatively small. The plume may interact with a nearby bank or shoreline.

5) Passive ambient mixing: After some distance the background turbulence in the ambient shear flow becomes the dominating mixing mechanism. The passive plume is growing in depth and in width. The plume may interact with the channel bottom and/or banks.

*** Predictions will be terminated in zone 4 or 5 depending on the definitions of the LEGAL MIXING ZONE or the REGION OF INTEREST. ***

SPECIAL CASE: If the ambient is stagnant, then advection and diffusion by the ambient flow (zones 4 and 5) cannot be considered. The mixing is limited to the hydrodynamic mixing zone (zones 1 to 3) and the predictions will be terminated at this stage. Such stagnant water predictions may be a useful initial mixing indicator for a given site and discharge design. For practical final predictions, however, the advection and diffusion of the ambient flow - no matter how small in magnitude - should be considered.

FLOW CLASS H4-180

A submerged buoyant effluent issues horizontally or near-horizontally from the discharge port. The discharge is directly opposed (or approximately so) to the direction of the ambient current. This is a highly complicated and UNDESIRABLE discharge configuration. Generally, the upstream issuing jet may exhibit an unsteady pulsating pattern with potential attachment to the bottom. There is no reliable prediction methodology for this flow.

CORMIX1 WILL NOT PROVIDE A DETAILED PREDICTION FOR THIS CASE.

FLOW CLASS H5-0

A submerged buoyant effluent issues horizontally or near-horizontally from the discharge port. The discharge is

co-flowing, or nearly co-flowing, with the ambient flow. The discharge configuration is hydrodynamically "unstable", that is the discharge strength (measured by its momentum flux) dominates the flow in relation to the limited layer depth. The effect of buoyancy is negligible and the initial discharge is usually attached to the bottom. The following flow zones exist:

1) Momentum-dominated near-field jet (bottom-attached): The flow is dominated by the effluent momentum (jet-like). The jet attaches to the bottom and is weakly advected by the ambient flow.

2) Layer boundary contact/full vertical mixing: After some distance the jet has grown vertically over the full layer depth. From now on the flow is vertically mixed and generally ceases to be jet-like.

3) Passive ambient mixing: The vertically fully mixed plume is further advected by the ambient flow and spreads laterally through turbulent diffusion. The plume may interact laterally with any nearby bank or shoreline.

*** The ambient flow plays an important role in this flow configuration. Hence, all the zones listed above constitute the HYDRODYNAMIC MIXING ZONE with strong initial mixing. Predictions will be terminated in zone 3 depending on the definitions of the LEGAL MIXING ZONE or the REGION OF INTEREST. ***

SPECIAL CASE: If the ambient is stagnant, so that advection and diffusion by the ambient flow (zone 3) cannot be considered. The mixing is limited to the discharge-induced mixing zones (zones 1 and 2) and the predictions will be terminated at this stage. Such predictions will present a conservative lower bound on the mixing capacity as they neglect any further mixing beyond the stage where the jet has grown to the full layer depth. Such stagnant water predictions may be a useful initial mixing indicator for a given site and discharge design. For practical final predictions, however, the advection and diffusion of the ambient flow - no matter how small in magnitude - should be considered.

FLOW CLASS H5-90

A submerged buoyant effluent issues horizontally or near-horizontally from the discharge port. The discharge is at, or approximately at, a right angle with the ambient current. The discharge configuration is hydrodynamically "unstable", that is the discharge strength (measured by its momentum flux) dominates the flow in relation to the limited layer

depth. The effect of buoyancy is negligible and the initial discharge is usually attached to the bottom. This is a highly complicated and UNDESIRABLE discharge configuration. The laterally discharging jet tends to full vertical mixing and will block the ambient flow. This will cause a recirculating eddy region downstream of the discharge. There is no reliable prediction methodology for this flow.

CORMIX1 WILL NOT PROVIDE A DETAILED PREDICTION FOR THIS CASE.

FLOW CLASS H5-180

A submerged buoyant effluent issues horizontally or near-horizontally from the discharge port. The discharge is directly opposed, or nearly opposed, to the direction of the ambient current. The discharge configuration is hydrodynamically "unstable", that is the discharge strength (measured by its momentum flux) dominates the flow in relation to the limited layer depth. The effect of buoyancy is negligible and the initial discharge is usually attached to the bottom. This is a highly complicated and UNDESIRABLE discharge configuration. Generally, the upstream issuing jet may exhibit an unsteady pulsating pattern and blocking of the ambient flow over the full water depth. There is no reliable prediction methodology for this flow.

CORMIX1 WILL NOT PROVIDE A DETAILED PREDICTION FOR THIS CASE.

C.3 S-Flow Classes

FLOW CLASS S1

This flow configuration is profoundly affected by the linear ambient density stratification. The predominantly jet-like flow gets trapped at some terminal (equilibrium) level. The trapping is also affected by the reasonably strong ambient crossflow. Following the trapping zone, the discharge flow forms an internal layer that is further influenced by buoyant spreading and passive diffusion. The following flow zones exist:

- 1) Momentum-dominated near-field jet: The flow is initially dominated by the effluent momentum (jet-like) and is weakly deflected by the ambient current.
- 2) Momentum-dominated far-field jet: The jet has become strongly deflected by the ambient current and is slowly rising toward the trapping level.

3) Terminal layer approach: The bent-over submerged jet/plume approaches the terminal level. Within a short distance the concentration distribution becomes relatively uniform across the plume width and thickness.

*** The zones listed above constitute the HYDRODYNAMIC MIXING ZONE in which strong initial mixing takes place.***

4) Buoyant spreading in internal layer: The discharge flow within the internal layer spreads laterally while it is being advected by the ambient current. The plume thickness may decrease during this phase. The mixing rate is relatively small. The plume may interact with a nearby bank or shoreline.

5) Passive ambient mixing: After some distance the background turbulence in the ambient shear flow becomes the dominating mixing mechanism. The passive plume is growing in depth and in width. The plume may interact with the upper layer boundary, channel bottom and/or banks.

*** Predictions will be terminated in zone 4 or 5 depending on the definitions of the LEGAL MIXING ZONE or the REGION OF INTEREST. ***

FLOW CLASS S2

This flow configuration is profoundly affected by the linear ambient density stratification. The predominantly jet-like flow issues vertically, or near-vertically, upward and gets trapped at some terminal (equilibrium) level. The crossflow is weak in the present situation. Following the trapping zone, the discharge flow forms an internal layer that is further influenced by buoyant spreading and passive diffusion. The following flow zones exist:

1) Momentum-dominated near-field jet in linear stratification: The flow is initially dominated by the effluent momentum (jet-like) and is weakly deflected by the ambient current and the density stratification.

2) Terminal layer impingement/upstream spreading: The weakly bent jet/plume approaches (impinges) the terminal layer at a near-vertical angle, and may overshoot that level to some extent. After impingement the flow spreads more or less radially at the terminal level forming an internal layer. In particular, the flow spreads some distance upstream against the ambient flow, and laterally across the ambient flow. This spreading is dominated by the buoyant collapse of the internal layer within the linear ambient stratification.

*** The zones listed above constitute the HYDRODYNAMIC MIXING ZONE in which strong initial mixing takes place.***

3) Buoyant spreading in internal layer: The discharge flow within the internal layer spreads laterally while it is being advected by the ambient current. The plume thickness may decrease during this phase. The mixing rate is relatively small. The plume may interact with a nearby bank or shoreline.

4) Passive ambient mixing: After some distance the background turbulence in the ambient shear flow becomes the dominating mixing mechanism. The passive plume is growing in depth and in width. The plume may interact with the upper layer boundary, channel bottom and/or banks.

*** Predictions will be terminated in zone 3 or 4 depending on the definitions of the LEGAL MIXING ZONE or the REGION OF INTEREST.***

SPECIAL CASE: If the ambient is stagnant, then advection and diffusion by the ambient flow (zones 3 and 4) cannot be considered. The mixing is limited to the hydrodynamic mixing zone (zones 1 and 2) and the predictions will be terminated at this stage. Such stagnant water predictions may be a useful initial mixing indicator for a given site and discharge design. For practical final predictions, however, the advection and diffusion of the ambient flow - no matter how small in magnitude - should be considered.

FLOW CLASS S3

This flow configuration is profoundly affected by the linear ambient density stratification. The predominantly jet-like flow issues horizontally, or near-horizontally, into the density stratified layer and gets trapped at some terminal (equilibrium) level. The crossflow is weak in the present situation. Following the trapping zone, the discharge flow forms an internal layer that is further influenced by buoyant spreading and passive diffusion. The following flow zones exist:

1) Momentum-dominated near-field jet in linear stratification: The flow is initially dominated by the effluent momentum (jet-like) and is weakly deflected by the ambient current and the density stratification.

2) Terminal layer injection/upstream spreading: The weakly bent jet/plume approaches (injects into) the terminal layer at a near-horizontal angle. After injection the flow spreads more or less radially at the terminal level forming an internal layer. The residual horizontal momentum flux

within the jet affects that spreading process. In particular, the flow spreads some distance upstream against the ambient flow, and laterally across the ambient flow. This spreading is dominated by the buoyant collapse of the internal layer within the linear ambient stratification.

*** The zones listed above constitute the HYDRODYNAMIC MIXING ZONE in which strong initial mixing takes place.***

3) Buoyant spreading in internal layer: The discharge flow within the internal layer spreads laterally while it is being advected by the ambient current. The plume thickness may decrease during this phase. The mixing rate is relatively small. The plume may interact with a nearby bank or shoreline.

4) Passive ambient mixing: After some distance the background turbulence in the ambient shear flow becomes the dominating mixing mechanism. The passive plume is growing in depth and in width. The plume may interact with the upper layer boundary, channel bottom and/or banks.

*** Predictions will be terminated in zone 3 or 4 depending on the definitions of the LEGAL MIXING ZONE or the REGION OF INTEREST. ***

SPECIAL CASE: If the ambient is stagnant, then advection and diffusion by the ambient flow (zones 3 and 4) cannot be considered. The mixing is limited to the hydrodynamic mixing zone (zones 1 and 2) and the predictions will be terminated at this stage. Such stagnant water predictions may be a useful initial mixing indicator for a given site and discharge design. For practical final predictions, however, the advection and diffusion of the ambient flow - no matter how small in magnitude - should be considered.

FLOW CLASS 84

This flow configuration is profoundly affected by the linear ambient density stratification. The predominantly plume-like flow gets trapped at some terminal (equilibrium) level. The trapping is also affected by the reasonably strong ambient crossflow. Following the trapping zone, the discharge flow forms an internal layer that is further influenced by buoyant spreading and passive diffusion. The following flow zones exist:

1) Momentum-dominated near-field jet: The flow is initially dominated by the effluent momentum (jet-like) and is weakly deflected by the ambient current.

2) Momentum-dominated far-field jet: The jet has become strongly deflected by the ambient current.

3) Buoyancy-dominated far-field plume: After some distance, the plume buoyancy starts to affect the flow. The plume is strongly deflected by the current and is slowly rising toward the terminal level.

4) Terminal layer approach: The bent-over submerged jet/plume approaches the terminal level. Within a short distance the concentration distribution becomes relatively uniform across the plume width and thickness.

***The zones listed above constitute the HYDRODYNAMIC MIXING ZONE in which strong initial mixing takes place. ***

5) Buoyant spreading in internal layer: The discharge flow within the internal layer spreads laterally while it is being advected by the ambient current. The plume thickness may decrease during this phase. The mixing rate is relatively small. The plume may interact with a nearby bank or shoreline.

6) Passive ambient mixing: After some distance the background turbulence in the ambient shear flow becomes the dominating mixing mechanism. The passive plume is growing in depth and in width. The plume may interact with the upper layer boundary, channel bottom and/or banks.

*** Predictions will be terminated in zone 5 or 6 depending on the definitions of the LEGAL MIXING ZONE or the REGION OF INTEREST. ***

FLOW CLASS 85

This flow configuration is profoundly affected by the linear ambient density stratification. The predominantly plume-like flow rises vertically upward and gets trapped at some terminal equilibrium level. The crossflow is weak in the present situation. Following the trapping zone, the discharge flow forms an internal layer that is further influenced by buoyant spreading and passive diffusion. The following flow zones exist:

1) Momentum-dominated near-field jet in linear stratification: The flow is initially dominated by the effluent momentum (jet-like) and is weakly deflected by the ambient current and the density stratification.

2) Buoyancy-dominated near-field plume in linear stratification: After some distance, the flow becomes dominated by the effluent buoyancy (plume-like) and is

weakly affected by the ambient current and the density stratification.

3) Terminal layer impingement/upstream spreading: The weakly bent jet/plume approaches (impinges) the terminal layer at a near-vertical angle, and may overshoot that level to some extent. After impingement the flow spreads more or less radially at the terminal level forming an internal layer. In particular, the flow spreads some distance upstream against the ambient flow, and laterally across the ambient flow. This spreading is dominated by the buoyant collapse of the internal layer within the linear ambient stratification.

*** The zones listed above constitute the HYDRODYNAMIC MIXING ZONE in which strong initial mixing takes place.***

4) Buoyant spreading in internal layer: The discharge flow within the internal layer spreads laterally while it is being advected by the ambient current. The plume thickness may decrease during this phase. The mixing rate is relatively small. The plume may interact with a nearby bank or shoreline.

5) Passive ambient mixing: After some distance the background turbulence in the ambient shear flow becomes the dominating mixing mechanism. The passive plume is growing in depth and in width. The plume may interact with the upper layer boundary, channel bottom and/or banks.

*** Predictions will be terminated in zone 4 or 5 depending on the definitions of the LEGAL MIXING ZONE or the REGION OF INTEREST. ***

SPECIAL CASE: If the ambient is stagnant, then advection and diffusion by the ambient flow (zones 4 and 5) cannot be considered. The mixing is limited to the hydrodynamic mixing zone (zones 1 to 3) and the predictions will be terminated at this stage. Such stagnant water predictions may be a useful initial mixing indicator for a given site and discharge design. For practical final predictions, however, the advection and diffusion of the ambient flow - no matter how small in magnitude - should be considered.

C.4 NV-Flow Classes

FLOW CLASS NV1

A submerged negatively buoyant effluent issues vertically or near-vertically from the discharge port. The effect of ambient velocity is relatively strong. The discharge configuration is hydrodynamically "stable", that is the discharge strength (measured by its momentum flux) is weak

in relation to the layer depth and in relation to the stabilizing effect of the negative discharge buoyancy (measured by its buoyancy flux). The following flow zones exist:

1) Momentum-dominated near-field jet: The flow is initially dominated by the upward effluent momentum (jet-like) and is weakly deflected by the ambient current.

2) Momentum-dominated far-field jet: The jet becomes strongly deflected by the ambient current. It rises to a maximum height, less than the layer depth, which is controlled by the opposing action of the negative buoyancy.

3) Buoyancy-dominated far-field plume: After the maximum height of rise, the negative discharge buoyancy becomes the dominating factor giving plume-like flow. The strongly deflected plume is slowly descending toward the bottom.

4) Bottom approach: The bent-over submerged plume approaches the bottom boundary. Within a short distance the concentration distribution becomes relatively uniform across the plume width and thickness.

*** The zones listed above constitute the HYDRODYNAMIC MIXING ZONE in which strong initial mixing takes place.***

5) Buoyant spreading at bottom boundary: The plume spreads laterally along the bottom while it is being advected by the ambient current. The plume thickness may decrease during this phase. The mixing rate is relatively small. The plume may interact with a nearby bank or shoreline.

6) Passive ambient mixing: After some distance the background turbulence in the ambient shear flow becomes the dominating mixing mechanism. The passive plume is growing in depth and in width. The plume may interact with the layer surface and/or banks.

*** Predictions will be terminated in zone 5 or 6 depending on the definitions of the LEGAL MIXING ZONE or the REGION OF INTEREST. ***

FLOW CLASS NV2

A submerged negatively buoyant effluent issues vertically or near-vertically from the discharge port. The effect of ambient velocity is weak. The discharge configuration is hydrodynamically "stable", that is the discharge strength (measured by its momentum flux) is weak in relation to the layer depth and in relation to the stabilizing effect of the

negative discharge buoyancy (measured by its buoyancy flux). The following flow zones exist:

1) Momentum-dominated near-field jet: The flow is initially dominated by the upward effluent momentum (jet-like) and is weakly deflected by the ambient current. It rises to a maximum height, less than the layer depth, which is controlled by the opposing action of the negative buoyancy.

2) Buoyancy-dominated near-field plume: After the maximum height of rise, the negative discharge buoyancy becomes the dominating factor (plume-like flow). The strongly deflected plume is rapidly falling toward the bottom.

3) Bottom boundary impingement/upstream spreading: The weakly bent jet/plume impinges on the bottom boundary at a near-vertical angle. After impingement the flow spreads more or less radially along the bottom. In particular, the flow spreads some distance upstream against the ambient flow, and laterally across the ambient flow. This spreading is dominated by the strong buoyancy of the discharge.

*** The zones listed above constitute the HYDRODYNAMIC MIXING ZONE in which strong initial mixing takes place.***

4) Buoyant spreading at bottom boundary: The plume spreads laterally along the bottom while it is being advected by the ambient current. The plume thickness may decrease during this phase. The mixing rate is relatively small. The plume may interact with a nearby bank or shoreline.

5) Passive ambient mixing: After some distance the background turbulence in the ambient shear flow becomes the dominating mixing mechanism. The passive plume is growing in depth and in width. The plume may interact with the layer surface and/or banks.

*** Predictions will be terminated in zone 4 or 5 depending on the definitions of the LEGAL MIXING ZONE or the REGION OF INTEREST. ***

SPECIAL CASE: If the ambient is stagnant, then advection and diffusion by the ambient flow (zones 4 and 5) cannot be considered. The mixing is limited to the hydrodynamic mixing zone (zones 1 to 3) and the predictions will be terminated at this stage. Such stagnant water predictions may be a useful initial mixing indicator for a given site and discharge design. For practical final predictions, however, the advection and diffusion of the ambient flow - no matter how small in magnitude - should be considered.

FLOW CLASS NV3

A submerged negatively buoyant effluent issues vertically or near-vertically from the discharge port. The effect of ambient velocity is relatively strong. The discharge configuration is hydrodynamically "stable", that is the discharge strength (measured by its momentum flux) is weak in relation to the layer depth and in relation to the stabilizing effect of the negative discharge buoyancy (measured by its buoyancy flux). The following flow zones exist:

1) Momentum-dominated near-field jet: The flow is initially dominated by the upward effluent momentum (jet-like) and is weakly deflected by the ambient current.

2) Momentum-dominated far-field jet: The jet becomes strongly deflected by the ambient current.

3) Layer boundary approach: The bent-over submerged jet/plume approaches the layer boundary (water surface or pycnocline). Within a short distance the concentration distribution becomes relatively uniform across the plume width and thickness.

4) Fall down: Because of the negative buoyancy the plume detaches from the layer boundary and starts to descend toward the bottom.

5) Buoyancy-dominated far-field plume: After the maximum height of rise, the negative discharge buoyancy becomes the dominating factor giving plume-like flow. The strongly deflected plume is slowly descending toward the bottom.

6) Bottom approach: The bent-over submerged plume approaches the bottom boundary. Within a short distance the concentration distribution becomes relatively uniform across the plume width and thickness.

*** The zones listed above constitute the HYDRODYNAMIC MIXING ZONE in which strong initial mixing takes place.***

7) Buoyant spreading at bottom boundary: The plume spreads laterally along the bottom while it is being advected by the ambient current. The plume thickness may decrease during this phase. The mixing rate is relatively small. The plume may interact with a nearby bank or shoreline.

8) Passive ambient mixing: After some distance the background turbulence in the ambient shear flow becomes the dominating mixing mechanism. The passive plume is growing

in depth and in width. The plume may interact with the layer surface and/or banks.

*** Predictions will be terminated in zone 7 or 8 depending on the definitions of the LEGAL MIXING ZONE or the REGION OF INTEREST. ***

FLOW CLASS NV4

A submerged negatively buoyant effluent issues vertically or near-vertically from the discharge port. The layer depth is limited. The discharge configuration is hydrodynamically "unstable", that is the discharge strength (measured by its momentum flux) dominates the flow in relation to the limited layer depth. The role of the negative buoyancy is secondary. The following flow zones exist:

1) Momentum-dominated near-field jet: The flow is dominated by the effluent momentum (jet-like) and is weakly deflected by the ambient current.

2) Layer boundary impingement/full vertical mixing: The weakly bent jet impinges on the layer boundary (water surface or pycnocline) at a near-vertical angle. Given the shallow layer depth and the weak buoyancy of the discharge, the flow becomes unstable after impingement. This results in a recirculating region immediately downstream that extends over the full layer depth.

3) Passive ambient mixing: The vertically fully mixed plume is further advected by the ambient flow and spreads laterally through ambient diffusion. The plume may interact with a nearby bank or shoreline.

*** The ambient flow plays an important role in this flow configuration. Hence, all the zones listed above constitute the HYDRODYNAMIC MIXING ZONE with strong initial mixing. Predictions will be terminated in zone 3 depending on the definitions of the LEGAL MIXING ZONE or the REGION OF INTEREST. ***

FLOW CLASS NV5

A submerged negatively buoyant effluent issues vertically or near-vertically from the discharge port. The layer depth is limited. The discharge configuration is hydrodynamically "unstable", that is the discharge strength (measured by its momentum flux) dominates the flow in relation to the limited layer depth and in relation to the weak stabilizing effect of the discharge buoyancy (measured by its buoyancy flux). However, the negative buoyancy is generally strong enough

to affect the flow at larger distances downstream from the unstable initial region. The following flow zones exist:

1) Unstable recirculation/buoyant restratification/upstream spreading: The buoyant jet rises near-vertically and impinges on the layer boundary (water surface or pycnocline). After impingement the mixed flow recirculates over the limited layer depth and becomes partially re-entrained into the discharge jet. The degree of recirculation - and hence the overall mixing in this region - is controlled by restratification of the flow at the edge of this recirculating region. The restratified flow spreads along the layer bottom. In particular, the flow spreads some distance upstream against the ambient current, and laterally across the ambient flow.

*** The region described above constitutes the HYDRODYNAMIC MIXING ZONE in which strong initial mixing takes place.***

2) Buoyant spreading at layer bottom: The plume spreads laterally along the bottom while it is being advected by the ambient current. The plume thickness may decrease during this phase. The mixing rate is relatively small. The plume may interact with a nearby bank or shoreline.

3) Passive ambient mixing: After some distance the background turbulence in the ambient shear flow becomes the dominating mixing mechanism. The passive plume is growing in depth and in width. The plume may interact with the layer upper boundary and/or banks.

*** Predictions will be terminated in zone 2 or 3 depending on the definitions of the LEGAL MIXING ZONE or the REGION OF INTEREST.***

SPECIAL CASE: If the ambient is stagnant, so that advection and diffusion by the ambient flow (zones 2 and 3) cannot be considered. The mixing is limited to the hydrodynamic mixing zone (zone

1) and the predictions will be terminated at this stage. Such stagnant water predictions may be a useful initial mixing indicator for a given site and discharge design. For practical final predictions, however, the advection and diffusion of the ambient flow - no matter how small in magnitude - should be considered.

C.5 NH-Flow Classes

FLOW CLASS NH1

A submerged negatively buoyant effluent issues horizontally or near-horizontally from the discharge port. The effect of ambient velocity is relatively strong. Alternatively, this flow may arise - even though the discharge may be positively buoyant - when the discharge is oriented downward and is arrested near the bottom by some ambient stratification. The discharge configuration is hydrodynamically "stable", that is the discharge strength (measured by its momentum flux) is weak in relation to the layer depth and in relation to the stabilizing effect of the negative discharge buoyancy (measured by its buoyancy flux). The following flow zones exist:

1) Momentum-dominated near-field jet: The flow is initially dominated by the effluent momentum (jet-like) and is weakly deflected by the ambient current. It rises to a maximum height (less than the layer depth) which is controlled by the negative buoyancy.

2) Buoyancy-dominated far-field plume: After the maximum height of rise, the negative discharge buoyancy becomes the dominating factor (plume-like flow). The strongly deflected plume is slowly descending toward the bottom.

3) Bottom approach: The bent-over submerged plume approaches the bottom boundary. Within a short distance the concentration distribution becomes relatively uniform across the plume width and thickness.

*** The zones listed above constitute the HYDRODYNAMIC MIXING ZONE in which strong initial mixing takes place.***

4) Buoyant spreading at bottom boundary: The plume spreads laterally along the bottom while it is being advected by the ambient current. The plume thickness may decrease during this phase. The mixing rate is relatively small. The plume may interact with a nearby bank or shoreline.

5) Passive ambient mixing: After some distance the background turbulence in the ambient shear flow becomes the dominating mixing mechanism. The passive plume is growing in depth and in width. The plume may interact with the layer surface and/or banks.

*** Predictions will be terminated in zone 5 or 6 depending on the definitions of the LEGAL MIXING ZONE or the REGION OF INTEREST. ***

FLOW CLASS NH2

A submerged negatively buoyant effluent issues horizontally or near-horizontally from the discharge port. The effect of ambient velocity is weak. Alternatively, this flow may arise - even though the discharge may be positively buoyant - when the discharge is oriented downward and is arrested near the bottom by some ambient stratification. The discharge configuration is hydrodynamically "stable", that is the discharge strength (measured by its momentum flux) is weak in relation to the layer depth and in relation to the stabilizing effect of the negative discharge buoyancy (measured by its buoyancy flux). The following flow zones exist:

1) Momentum-dominated near-field jet: The flow is initially dominated by the effluent momentum (jet-like) and is weakly deflected by the ambient current. It rises to a maximum height (less than the layer depth) which is controlled by the negative buoyancy.

2) Buoyancy-dominated near-field plume: After the maximum height of rise, the negative discharge buoyancy becomes the dominating factor (plume-like flow). The strongly deflected plume is rapidly falling toward the bottom.

3) Bottom boundary impingement/upstream spreading: The weakly bent jet/plume impinges on the bottom boundary at a near-vertical angle. After impingement the flow spreads more or less radially along the bottom. In particular, the flow spreads some distance upstream against the ambient flow, and laterally across the ambient flow. This spreading is dominated by the strong buoyancy of the discharge.

*** The zones listed above constitute the HYDRODYNAMIC MIXING ZONE in which strong initial mixing takes place.***

4) Buoyant spreading at bottom boundary: The plume spreads laterally along the bottom while it is being advected by the ambient current. The plume thickness may decrease during this phase. The mixing rate is relatively small. The plume may interact with a nearby bank or shoreline.

5) Passive ambient mixing: After some distance the background turbulence in the ambient shear flow becomes the dominating mixing mechanism. The passive plume is growing in depth and in width. The plume may interact with the layer surface and/or banks.

*** Predictions will be terminated in zone 4 or 5 depending on the definitions of the LEGAL MIXING ZONE or the REGION OF INTEREST. ***

SPECIAL CASE: If the ambient is stagnant, then advection and diffusion by the ambient flow (zones 4 and 5) cannot be considered. The mixing is limited to the hydrodynamic mixing zone (zones 1 to 3) and the predictions will be terminated at this stage. Such stagnant water predictions may be a useful initial mixing indicator for a given site and discharge design. For practical final predictions, however, the advection and diffusion of the ambient flow - no matter how small in magnitude - should be considered.

FLOW CLASS NH3

A submerged negatively buoyant effluent issues horizontally or near-horizontally from the discharge port. The discharge is cross-flowing or counterflowing with respect to the ambient flow, and the ambient velocity is weak. Alternatively, this flow may arise - even though the discharge may be positively buoyant - when the discharge is oriented downward and is arrested near the bottom by some ambient stratification. The discharge configuration is hydrodynamically "stable", that is the discharge strength (measured by its momentum flux) is weak in relation to the layer depth and in relation to the stabilizing effect of the negative discharge buoyancy (measured by its buoyancy flux). The following flow zones exist:

- 1) Momentum-dominated near-field jet: The flow is initially dominated by the effluent momentum (jet-like) and is weakly deflected by the ambient current.
- 2) Buoyancy-dominated near-field plume: After some distance, the negative discharge buoyancy becomes the dominating factor (plume-like flow). The strongly deflected plume is descending toward the bottom.
- 3) Bottom approach: The bent-over submerged plume approaches the bottom boundary. Within a short distance the concentration distribution becomes relatively uniform across the plume width and thickness.
- 4) Wall jet: The bottom attached flow forms a wall jet that propagates across or against the ambient flow.
- 5) Flow turning: At some distance the wall jet becomes turned into the ambient flow direction. Also, the concentration distribution becomes relatively uniform across the plume width and thickness.

***** The zones listed above constitute the HYDRODYNAMIC MIXING ZONE in which strong initial mixing takes place.*****

6) Buoyant spreading at bottom boundary: The plume spreads laterally along the bottom while it is being advected by the ambient current. The plume thickness may decrease during this phase. The mixing rate is relatively small. The plume may interact with a nearby bank or shoreline. 7) Passive ambient mixing: After some distance the background turbulence in the ambient shear flow becomes the dominating mixing mechanism. The passive plume is growing in depth and in width. The plume may interact with the layer surface and/or banks.

*** Predictions will be terminated in zone 6 or 7 depending on the definitions of the LEGAL MIXING ZONE or the REGION OF INTEREST.***

COUNTERFLOW DISCHARGE: If the discharge is opposing the ambient flow then the flow pattern tends to become complicated and irregular with potential unsteady pulsations. This is an UNDESIRABLE discharge configuration.

CORMIX1 WILL NOT PROVIDE A DETAILED PREDICTION FOR A COUNTERFLOW DISCHARGE GEOMETRY.

SPECIAL CASE: If the ambient is stagnant, then advection and diffusion by the ambient flow (zones 4 to 7) cannot be considered. The mixing is limited to the hydrodynamic mixing zone (zones 1 to 3) and the predictions will be terminated at this stage. Such stagnant water predictions may be a useful initial mixing indicator for a given site and discharge design. For practical final predictions, however, the advection and diffusion of the ambient flow - no matter how small in magnitude - should be considered.

FLOW CLASS NH4

A submerged negatively buoyant effluent issues horizontally or near-horizontally from the discharge port. The effect of ambient velocity is relatively strong. Alternatively, this flow may arise - even though the discharge may be positively buoyant - when the discharge is oriented downward and is arrested near the bottom by some ambient stratification. The following flow zones exist:

1) Momentum-dominated near-field jet: The flow is initially dominated by the effluent momentum (jet-like) and is weakly deflected by the ambient current.

2) Momentum-dominated far-field jet: The jet becomes strongly deflected by the ambient current. It rises to a maximum height, less than the layer depth, which is controlled by the opposing action of the negative buoyancy.

3) Buoyancy-dominated far-field plume: After the maximum height of rise, the negative discharge buoyancy becomes the dominating factor in plume-like flow. The strongly deflected plume is slowly descending toward the bottom.

4) Bottom approach: The bent-over submerged plume approaches the bottom boundary. Within a short distance the concentration distribution becomes relatively uniform across the plume width and thickness.

*** The zones listed above constitute the HYDRODYNAMIC MIXING ZONE in which strong initial mixing takes place.***

5) Buoyant spreading at bottom boundary: The plume spreads laterally along the bottom while it is being advected by the ambient current. The plume thickness may decrease during this phase. The mixing rate is relatively small. The plume may interact with a nearby bank or shoreline.

6) Passive ambient mixing: After some distance the background turbulence in the ambient shear flow becomes the dominating mixing mechanism. The passive plume is growing in depth and in width. The plume may interact with the layer surface and/or banks.

*** Predictions will be terminated in zone 5 or 6 depending on the definitions of the LEGAL MIXING ZONE or the REGION OF INTEREST.***

FLOW CLASS NHS

A submerged negatively buoyant effluent issues horizontally or near-horizontally from the discharge port. The discharge is cross-flowing or counterflowing with respect to the ambient current. The discharge configuration is hydrodynamically "unstable", that is the discharge strength (measured by its momentum flux) dominates the flow in relation to the limited layer depth. The effect of buoyancy is negligible and the initial discharge is usually attached to the bottom. This is a highly complicated and UNDESIRABLE discharge configuration. The discharging jet tends to full vertical mixing and will block the ambient flow. This will cause a recirculating eddy region downstream of the discharge. There is no reliable prediction methodology for this flow.

CORMIX1 WILL NOT PROVIDE A DETAILED PREDICTION FOR THIS CASE.

C.6 Attached Flow Classes

FLOW CLASS (..)A1

Irrespective of the buoyancy or direction of the discharge, the near-field of this flow configuration is dominated by wake attachment. The ambient crossflow effect is strong and/or the height of the discharge port above the bottom is too small. This leads to rapid attachment of the discharge flow to the bottom with a recirculation wake in the lee of the discharge structure. Following the recirculation the discharge flow will lift off from the bottom due to its strong buoyancy.

FLOW CLASS (..)A2

Irrespective of the buoyancy or direction of the discharge, the near-field of this flow configuration is dominated by wake attachment. The ambient crossflow effect is strong and/or the height of the discharge port above the bottom is too small. This leads to rapid attachment of the discharge flow to the bottom with a recirculation wake in the lee of the discharge structure. Following the recirculation the discharge flow will remain attached to the bottom due to its weaker negative buoyancy. In the absence of wake attachment the dominant flow class would be given by the prefix (..). You may request detailed information on that flow class further below. Additional advice on how to prevent bottom attachment (e.g. by increasing the height of the discharge port) will be provided in the summary program element SUM. The following flow zones exist:

- 1) Recirculation zone: The discharge flow becomes quickly deflected by the ambient flow and attaches to the bottom. A recirculation eddy exists in the lee of the discharge structure.
- 2) Buoyant spreading at bottom: In case of negative discharge buoyancy only, the plume spreads laterally along the bottom while it is being advected by the ambient current. The plume thickness may decrease during this phase. The mixing rate is relatively small. The plume may interact with a nearby bank or shoreline.
- 3) Passive ambient mixing: After some distance the background turbulence in the ambient shear flow becomes the dominating mixing mechanism. The passive plume is growing in thickness and in width. The plume may interact with the layer upper boundary and/or banks.

***The ambient flow plays an important role in this flow configuration. Hence, all the zones listed above constitute

the HYDRODYNAMIC MIXING ZONE with strong initial mixing. Predictions will be terminated in zones 2 or 3 depending on the definitions of the LEGAL MIXING ZONE or the REGION OF INTEREST.***

FLOW CLASS (..)A3

Controlled primarily by the geometry of the discharge, the near-field of this flow configuration is dominated by Coanda attachment. The port orientation is more or less horizontal and/or the height of the discharge port above the bottom is too small. This leads to rapid dynamic attachment (Coanda attachment) of the discharge flow to the bottom and the formation of a wall jet. At some distance the discharge flow will lift off from the bottom due to its strong buoyancy. In the absence of Coanda attachment the dominant flow class would be given by the prefix (..). You may request detailed information on that flow class further below. Additional advice on how to prevent bottom attachment (e.g. by increasing the vertical angle of the discharge port) will be provided in the summary program element SUM. The following flow zones exist:

1) Momentum-dominated near-field wall jet: The rapidly attaching discharge flow (wall jet) is initially dominated by the effluent momentum and weakly deflected by the ambient current.

2) Momentum-dominated far-field wall jet: The wall jet has become strongly deflected by the ambient current. Depending on the ratio of the jet to plume transition length scale to the jet to crossflow length scale this flow zone may be absent.

3) Lift-off: Because of the positive buoyancy the plume detaches from the bottom and starts to rise upward.

4) Buoyancy-dominated far-field plume: The plume has been strongly deflected by the current and is slowly rising toward the surface.

5) Layer boundary approach: The bent-over submerged jet/plume approaches the layer boundary (water surface or pycnocline). Within a short distance the concentration distribution becomes relatively uniform across the plume width and thickness.

*** The zones listed above constitute the HYDRODYNAMIC MIXING ZONE in which strong initial mixing takes place.***

6) Buoyant spreading at layer boundary: The plume spreads laterally along the layer boundary (surface or pycnocline)

while it is being advected by the ambient current. The plume thickness may decrease during this phase. The mixing rate is relatively small. The plume may interact with a nearby bank or shoreline.

7) Passive ambient mixing: After some distance the background turbulence in the ambient shear flow becomes the dominating mixing mechanism. The passive plume is growing in depth and in width. The plume may interact with the channel bottom and/or banks.

*** Predictions will be terminated in zone 6 or 7 depending on the definitions of the LEGAL MIXING ZONE or the REGION OF INTEREST.***

FLOW CLASS (..)A4

Controlled primarily by the geometry of the discharge, the near-field of this flow configuration is dominated by Coanda attachment. The port orientation is more or less horizontal and/or the height of the discharge port above the bottom is too small. This leads to rapid dynamic attachment (Coanda attachment) of the discharge flow to the bottom and the formation of a wall jet. At some distance the discharge flow will lift off from the bottom due to its strong buoyancy. In the absence of Coanda attachment the dominant flow class would be given by the prefix (..). You may request detailed information on that flow class further below. Additional advice on how to prevent bottom attachment (e.g. by increasing the vertical angle of the discharge port) will be provided in the summary program element SUM. The following flow zones exist:

- 1) Momentum-dominated near-field wall jet: The rapidly attaching discharge flow (wall jet) is initially dominated by the effluent momentum and weakly deflected by the ambient current.
- 2) Lift-off: Because of the positive buoyancy the plume detaches from the bottom and starts to rise upward.
- 3) Buoyancy-dominated near-field plume: The plume is quickly rising and weakly deflected by the ambient current.
- 4) Layer boundary impingement/upstream spreading: The weakly bent jet/plume impinges on the layer boundary (water surface or pycnocline) at a near-vertical angle. After impingement the flow spreads more or less radially along the layer boundary. In particular, the flow spreads some distance upstream against the ambient flow, and laterally across the ambient flow. This spreading is dominated by the strong buoyancy of the discharge.

*** The zones listed above constitute the HYDRODYNAMIC MIXING ZONE in which strong initial mixing takes place.***

5) Buoyant spreading at layer boundary: The plume spreads laterally along the layer boundary (surface or pycnocline) while it is being advected by the ambient current. The plume thickness may decrease during this phase. The mixing rate is relatively small. The plume may interact with a nearby bank or shoreline.

6) Passive ambient mixing: After some distance the background turbulence in the ambient shear flow becomes the dominating mixing mechanism. The passive plume is growing in depth and in width. The plume may interact with the channel bottom and/or banks.

*** Predictions will be terminated in zone 5 or 6 depending on the definitions of the LEGAL MIXING ZONE or the REGION OF INTEREST.***

SPECIAL CASE: If the ambient is stagnant, then advection and diffusion by the ambient flow (zones 5 and 6) cannot be considered. The mixing is limited to the hydrodynamic mixing zone (zones 1 to 4) and the predictions will be terminated at this stage. Such stagnant water predictions may be a useful initial mixing indicator for a given site and discharge design. For practical final predictions, however, the advection and diffusion of the ambient flow - no matter how small in magnitude - should be considered.

FLOW CLASS (..)A5

Controlled primarily by the geometry of the discharge, the near-field of this flow configuration is dominated by Coanda attachment. The port orientation is more or less horizontal and/or the height of the discharge port above the bottom is too small. This leads to rapid dynamic attachment (Coanda attachment) of the discharge flow to the bottom and the formation of a wall jet. The discharge flow will remain attached to the bottom due to its weak or negative buoyancy. In the absence of Coanda attachment the dominant flow class would be given by the prefix (..). You may request detailed information on that flow class further below. Additional advice on how to prevent bottom attachment (e.g. by increasing the vertical angle of the discharge port) will be provided in the summary program element SUM. The following flow zones exist:

1) Momentum-dominated near-field wall jet: The rapidly attaching discharge flow (wall jet) is initially dominated

by the effluent momentum and weakly deflected by the ambient current.

2) Momentum-dominated far-field wall jet: The wall jet has become strongly deflected by the ambient current.

3) Flow turning: At some distance the wall jet becomes turned into the ambient flow direction. Also, the concentration distribution becomes relatively uniform across the plume width and thickness.

*** The zones listed above constitute the HYDRODYNAMIC MIXING ZONE in which strong initial mixing takes place.***

4) Buoyant spreading at bottom: The plume spreads laterally along the bottom while it is being advected by the ambient current. The plume thickness may decrease during this phase. The mixing rate is relatively small. The plume may interact with a nearby bank or shoreline.

6) Passive ambient mixing: After some distance the background turbulence in the ambient shear flow becomes the dominating mixing mechanism. The passive plume is growing in depth and in width. The plume may interact with the channel bottom and/or banks.

***Predictions will be terminated in zone 4 or 5 depending on the definitions of the LEGAL MIXING ZONE or the REGION OF INTEREST. ***

SPECIAL CASE: If the ambient is stagnant, then advection and diffusion by the ambient flow (zones 4 and 5) cannot be considered. The mixing is limited to the hydrodynamic mixing zone (zones 1 to 3) and the predictions will be terminated at this stage. Such stagnant water predictions may be a useful initial mixing indicator for a given site and discharge design. For practical final predictions, however, the advection and diffusion of the ambient flow - no matter how small in magnitude - should be considered.

Appendix D

HYDRO Output File Example

This Fortran output file corresponds to the AB Chemical Company Design Case No.2 in Section 7.1.2.

SIMULATION / CASE DESCRIPTION

SITE NAME: AB-1
DISCHARGER NAME: NEW
POLLUTANT NAME: ANGLES-HO
DESIGN CASE: TEST

DOS FILE NAME: AB-1
DATE AND TIME OF FORTRAN SIMULATION: 06-08-1989_15:09:37

ENVIRONMENT PARAMETERS (METRIC UNITS)

BOUNDED SECTION

BS	=	262.75	AS	=	3153.00
BANK	=	left	YB	=	37.50
HA	=	12.00	HD	=	12.00
UA	=	.30	F	=	.0198

UNIFORM DENSITY ENVIRONMENT

RHOA = 998.39

DISCHARGE PARAMETERS (METRIC UNITS)

DO	=	.15000E+00	AO	=	-.17671E-01	HO	=	.40
THETA0	=	30.00	SIGMA0	=	-270.00			
UO	=	-.30000E+01	QO	=	-.53014E-01			
RHOO	=	987.80	DRHOO	=	10.5840	GPO	=	.1040E+00
CO	=	-.50000E+03						

FLUX PARAMETERS (METRIC UNITS)

QO = .53014E-01 MO = .15904E+00 JO = .5511E-02 SIGNJO = 1.0

FLOW CLASSIFICATION

FLOW CLASS: H1
FLOW DIRECTION: upward

ATTACHMENT TYPE: NONE

HS - 12.00

NON-DIMENSIONAL PARAMETERS

FRO - 24.02 R - 10.00

LENGTH SCALES (METRIC UNITS)

LQ - .1329 LM - 3.3924 Lm - 1.3293 Lb -
.2041

MIXING ZONE / TOXIC DILUTION / AREA OF INTEREST PARAMETERS

CO - .50000E+03
NTOX - 1 CMC - .25E+02
XINT - .30E+04
LEGMZ - 1 LEGSPC - 2 LEGVAL - 26.27
XLEG - .00E+00 WLEG - .26E+02 ALEG - .00E+00
XMAX - .30E+04
NSTEP - 6

SUBSURFACE FLOW: MDNF -> MDFF -> BDF

BEGIN MOD01: DISCHARGE MODULE

PREDICTION

X	Y	Z	S	C	B
.00	.00	.40	1.00	.500E+03	.08

END OF MOD01: DISCHARGE MODULE

BEGIN MOD11 MDNF: MOMENTUM DOMINATED NEAR-FIELD

COORDINATES

GAMMA - 90.00 DELTA - 150.00

45 < GAMMA < 135 DEGREES
JET INTO CROSSFLOW

STARTING VALUES

ETA I - .4000 XI - .0000 YI - .0000 ZI - .4000
 ETAIP - .7385 XIP - .0775 YIP - -.6396 ZIP - .3714

VIRTUAL ORIGIN LOCATION

ETA V - -.3385 XV - -.0775 YV - .6396 ZV - .0286

FINAL VALUES

ETA F - 2.3201 XF - .9275 YF - -1.6629 ZF - 1.4569
 ETAFP - 2.6586 XFP - 1.0050 YFP - -2.3025 ZFP - 1.4283

PREDICTION

X	Y	Z	S	C	B
.00	.00	.40	1.00	.500E+03	.08
.08	-.28	.56	1.43	.349E+03	.12
.19	-.55	.73	1.87	.268E+03	.15
.33	-.83	.90	2.30	.217E+03	.19
.50	-1.11	1.08	2.73	.183E+03	.22
.70	-1.39	1.27	3.17	.158E+03	.26
.93	-1.66	1.46	3.60	.139E+03	.29

END OF MOD11 MDNF: MOMENTUM DOMINATED NEAR-FIELD

 BEGIN MOD16 MDFF: MOMENTUM DOMINATED FAR FIELD

STARTING VALUES

ETA I - 2.2108 XI - .9275 YI - -1.6629 ZI - 1.4569
 ETAIP - 1.4562 XIP - .4266 YIP - -1.2611 ZIP - .7280

VIRTUAL ORIGIN LOCATION

ETA V - .7546 XV - .5008 YV - -.4018 ZV - .7289

FINAL VALUES

ETA F - 4.4015 XF - 7.2018 YF - -3.5601 ZF - 2.0958
 ETAFP - 3.6469 XFP - 6.7009 YFP - -3.1583 ZFP - 1.3669

PREDICTION

X	Y	Z	S	C	B
---	---	---	---	---	---

.93	-1.66	1.46	3.60	.139E+03	.44
1.97	-2.31	1.75	8.22	.608E+02	.66
3.02	-2.68	1.88	11.76	.425E+02	.79
4.06	-2.96	1.97	14.82	.337E+02	.89
5.11	-3.19	2.03	17.59	.284E+02	.97

THE POLLUTANT CONCENTRATION IN THE PLUME FALLS BELOW THE
CMC VALUE OF .25E+02 IN THE CURRENT PREDICTION INTERVAL.

THIS IS THE EXTENT OF THE TOXIC DILUTION ZONE.

6.16	-3.39	2.07	20.16	.248E+02	1.03
7.20	-3.56	2.10	22.57	.221E+02	1.09

END OF MOD16 MDFF: MOMENTUM DOMINATED FAR FIELD

BEGIN MOD22 BDFF: BUOYANCY DOMINATED FAR-FIELD

STARTING VALUES

XI -	7.2018	YI -	-3.5601	ZI -	2.0958
XIP -	13.7306	YIP -	-4.4148	ZIP -	3.3763

VIRTUAL ORIGIN LOCATION

XV -	-6.5288	YV -	.8548	ZV -	-1.2805
------	---------	------	-------	------	---------

FINAL VALUES

XF -	100.5842	YF -	-7.9005	ZF -	12.0000
XFP -	107.1130	YFP -	-8.7553	ZFP -	13.2805

PREDICTION

X	Y	Z	S	C	B
7.20	-3.56	2.10	22.57	.222E+02	1.01
22.77	-4.83	4.31	61.99	.807E+01	1.68
38.33	-5.70	6.15	109.40	.457E+01	2.23
53.89	-6.38	7.78	162.73	.307E+01	2.72
69.46	-6.95	9.28	220.89	.226E+01	3.17
85.02	-7.45	10.68	283.18	.177E+01	3.59
100.58	-7.90	12.00	349.11	.143E+01	3.98

END OF MOD22 BDFF: BUOYANCY DOMINATED FAR-FIELD

BEGIN MOD31: LAYER/BOUNDARY/TERMINAL LAYER APPROACH

CONTROL VOLUME

PREDICTION

X	Y	Z	S	C	B
100.58	-7.90	12.00	349.3	.143E+01	3.98

X	Y	Z	S	C	BV	BH	ZU	ZL
108.55	-7.90	12.00	593.9	.842E+00	7.24	7.24	12.00	4.76

END OF MOD31: LAYER/BOUNDARY/TERMINAL LAYER APPROACH

*** END HYDRODYNAMIC MIXING ZONE (HMZ) ***

BEGIN MOD41: BUOYANT AMBIENT SPREADING

PREDICTION STAGE 1 NOT BANK ATTACHED

X	Y	Z	S	C	BV	BH	ZU	ZL
108.55	-7.90	12.00	593.9	.842E+00	7.24	7.24	12.00	4.76

** LEGAL MIXING ZONE BOUNDARY **

IN THIS PREDICTION INTERVAL THE PLUME WIDTH MEETS OR EXCEEDS
THE LEGAL VALUE - 26.27 M. THIS IS THE EXTENT OF THE LEGAL MIXING
ZONE.

X	Y	Z	S	C	BV	BH	ZU	ZL
229.67	-7.90	12.00	717.3	.697E+00	4.11	15.42	12.00	7.89
350.78	-7.90	12.00	781.9	.639E+00	3.17	21.77	12.00	8.83
471.89	-7.90	12.00	827.4	.604E+00	2.68	27.30	12.00	9.32
593.01	-7.90	12.00	863.0	.579E+00	2.36	32.31	12.00	9.64
714.12	-7.90	12.00	892.5	.560E+00	2.13	36.96	12.00	9.87
835.23	-7.90	12.00	917.9	.545E+00	1.96	41.33	12.00	10.04

END MOD41: BUOYANT AMBIENT SPREADING

BOTTOM COORDINATE FOR FAR-FIELD IS DETERMINED BY AVERAGE DEPTH,
ZFB = 0.0

BEGIN MOD61: PASSIVE AMBIENT MIXING IN UNIFORM AMBIENT

VERTICAL DIFFUSIVITY OF AMBIENT FLOW: EDIFFV = .0358(M**2/S)

HORIZONTAL DIFFUSIVITY OF AMBIENT FLOW: EDIFFH = .0894(M**2/S)

PREDICTION STAGE 1 NOT BANK ATTACHED

X	Y	Z	S	C	BV	BH	ZU	ZL
835.23	-7.90	12.00	917.9	.545E+00	1.96	41.33	12.00	10.04
898.00	-7.90	12.00	2489.0	.201E+00	5.23	42.04	12.00	6.77
960.77	-7.90	12.00	3449.9	.145E+00	7.13	42.73	12.00	4.87
1023.53	-7.90	12.00	4238.3	.118E+00	8.63	43.41	12.00	3.37
1086.30	-7.90	12.00	4937.4	.101E+00	9.90	44.09	12.00	2.10
1149.06	-7.90	12.00	5581.0	.896E-01	11.02	44.75	12.00	.98

PLUME INTERACTS WITH BOTTOM

THE PASSIVE DIFFUSION PLUME BECOMES VERTICALLY FULLY MIXED WITHIN THIS
PREDICTION INTERVAL.

1211.83	-7.90	12.00	6166.1	.811E-01	12.00	45.40	12.00	.00
---------	-------	-------	--------	----------	-------	-------	-------	-----

SIMULATION LIMIT BASED ON MAXIMUM SPECIFIED DISTANCE = 3000.00(M).

THIS IS THE REGION OF INTEREST LIMITATION.

PREDICTION STAGE 2 BANK ATTACHED

X	Y	Z	S	C	BV	BH	ZU	ZL
1211.83	37.50	12.00	6166.1	.811E-01	12.00	90.80	12.00	.00
1509.86	37.50	12.00	6269.6	.797E-01	12.00	92.33	12.00	.00
1807.89	37.50	12.00	6371.5	.785E-01	12.00	93.83	12.00	.00
2105.91	37.50	12.00	6471.7	.773E-01	12.00	95.30	12.00	.00
2403.94	37.50	12.00	6570.4	.761E-01	12.00	96.75	12.00	.00
2701.97	37.50	12.00	6667.7	.750E-01	12.00	98.19	12.00	.00
3000.00	37.50	12.00	6763.5	.739E-01	12.00	99.60	12.00	.00

END MOD61: PASSIVE AMBIENT MIXING IN UNIFORM LAYER

Appendix E

SUM Case Summary and Design Recommendations Example

The following represents the SUM knowledge base output file from the winter design case for the MN municipal treatment plant in section 7.2.2.

***** CASE SUMMARY *****

SIMULATION / CASE DESCRIPTION

Site name: MN-2
Discharger name: WEAK
Pollutant name: STRATIFICATION
Design case: TEST
Dos file name: MN-2
Date and time of FORTRAN simulation: 08-09-1989 08:47:46

DISCHARGE/ENVIRONMENT DATA:

ENVIRONMENT PARAMETERS (METRIC UNITS)

Bounded section - no
Bounded section width - 88888.8 (m)
Nearest bank - left (m)
Location of discharge from bank - 1000. (m)
Average depth - 24.35 (m)
Depth at discharge - 24.35 (m)
Ambient velocity - .25 (m/s)
Darcy F - .02

Stratification Type - A
Surface density - 1025.60 (kg/m**3)
Pycnocline density - 0.0 (kg/m**3)
Bottom density - 1025.76 (kg/m**3)
Layer height - 24.35 (m)

DISCHARGE PARAMETERS (METRIC UNITS)

Port diameter - .5 (m)
Port area - .19635 (m**2)
Discharge port height - 0.5 (m)
Vertical angle of discharge - 30 (deg)
Horizontal angle of discharge - (deg)
Discharge velocity - 3. (m/s)
Discharge density - 1015.00 (kg/m**3)
Density difference - 10.679932 (kg/m**3)
Buoyant acceleration - .10 (m**2/s)

Discharge concentration - 100.000000

FLUX PARAMETERS (METRIC UNITS)

Discharge flow rate - 0.589032 m**3/s
Momentum flux - 1.76 m**4/s**2
Buoyancy flux - 0.060147 m**4/s**3

NON-DIMENSIONAL PARAMETERS

Froude Number - 13.276936
Velocity Ratio - 12

DISCHARGE/ENVIRONMENT LENGTH SCALES (m):

LQ = .44 Lm = 5.31 Lb = 3.84
LM = 6.24 Lm' = 99999.90 Lb' = 99999.90

(These refer to the final discharge/environment length scales as concluded in CLASS)

MIXING ZONE / TOXIC DILUTION ZONE / AREA OF INTEREST PARAMETERS

Toxic discharge - yes
CMC concentration - 10.000000
Legal mixing zone - yes
Legal mixing zone specification - width
Legal mixing zone value - 200. (m, or m**2)
Region of interest - yes
Region of interest distance - 2000. m

*** SUMMARY OF HYDRODYNAMIC SIMULATION AND MIXING ZONE PREDICTION ***

Flow Class - H1
Attachment type - NONE

This flow configuration applies to a layer corresponding to the full water depth at the discharge site. The ambient density stratification at the discharge site is relatively weak and unimportant so the discharge flow penetrates to the surface and/or breaks down the existing stratification through vigorous mixing.

HYDRODYNAMIC MIXING ZONE (HMZ) CONDITIONS :

Note: The HMZ is the zone of strong initial mixing. It has no legal implication. However, this information may be useful for the discharge designer because the mixing in the HMZ is usually sensitive to the discharge design conditions.

Pollutant concentration at edge of HMZ = .67
Dilution at edge of HMZ = 149.19

HMZ Location (centerline coordinates) (m):
x = 81.79 y = .00 z = 24.35
HMZ Plume Dimensions (m):
plume half-width = 13.25 plume thickness = 13.25

REGION OF INTEREST (ROI) CONDITIONS :

Minimum pollutant concentration at edge of ROI = .339
Corresponding dilution at edge of ROI = 294.8
ROI Location (centerline coordinates) (m):
x = 2000.00 y = .00 z = 24.35
ROI Plume Dimensions (m):
plume half-width = 202. plume thickness = 1.72

***** MIXING ZONE PREDICTION SUMMARY *****

LEGAL MIXING ZONE (LMZ) CONDITIONS :

Predicted minimum pollutant concentration at edge of LMZ = .402060
Corresponding dilution at edge of LMZ = 248.719300
LMZ Location (centerline coordinates) (m):
x = 753.166900 y = .000000 z = 24.350000
LMZ Plume Dimensions (m):
plume half-width = 102.400900 plume thickness = 2.861374
At this position, the flow is still unattached to any bank.

***** TOXIC DILUTION ZONE SUMMARY *****

TOXIC DILUTION ZONE (TDZ) ANALYSIS:

Criterion maximum concentration (CMC) = 10.000000
Toxic dilution zone downstream distance = 16.28 (m).

The exit velocity of the discharge from the port is equal to 3. m/s and is greater than the minimum of 3.0 m/s.

* The discharge velocity test for TDZ has been satisfied. *
The downstream distance equal to 16.28 (m) at which to flow equals the criterion maximum concentration (CMC) is less than or equal to 50 times the discharge length scale of LQ = 0.4 (m).

* The discharge length scale test for TDZ has been satisfied. * The criterion maximum concentration (CMC) has been met at a distance downstream equal to 16.28 (m) which is less than or equal to 5 times the ambient water depth HD = 24.35 (m).

* The ambient depth test for TDZ has been satisfied.*
The criterion maximum concentration (CMC) of CMC has been met
at 16.28 (m) downstream which is less than or equal to one tenth the
distance of the of the legal mixing zone of 753.166900 (m)
downstream.

* The legal mixing zone test for TDZ has been satisfied. *

**** All criteria for TDZ are satisfied for this configuration. ****

TOXIC DILUTION ZONE (TDZ) CONDITIONS :

Note: The TDZ corresponds to the criteria issued in the USEPA Technical
Support Document "Technical Support Document for Water Quality-based
Toxics Control", Office of Water, Washington, D.C., September, 1985.

Maximum pollutant concentration at edge of TDZ = 9.83
Corresponding dilution at edge of TDZ = 10.165760

TDZ Location (centerline coordinates) (m):
x = 16.28 y = .00 z = 8.25

TDZ Plume Dimensions (m):
plume half-width = 2.68 plume thickness = .00

***** NOTICE *****

If you desire detailed printed information on the present discharge case
you can obtain this by issuing the following DOS command after you have
returned to DOS:

print c:\cmx\sim\MN-2.cxo

This gives a detailed listing of the results of the hydrodynamic
simulation program element HYDRO. This information may be useful if
you want to construct graphical displays of the flow configuration or
if you want to compare results with available field or laboratory data.

print c:\cmx\desc\H1des

The detailed description of the flow configuration for the unattached
flow class H1 will be printed.

*****DESIGNRECOMMENDATIONS*****

A reliable environmental analysis and mixing zone prediction is possible
only if each design case is evaluated through several iterations of
CORMIX1. Small changes in ambient or discharge design conditions can
sometimes cause drastic shifts in the applicable flow configuration

(flow class) and the size or appearance of mixing zones. Iterative use of CORMIX1 will give information on the sensitivity of predicted results on design and ambient conditions. Each predictive case should be carefully assessed as to: - size and shape of LMZ - conditions in the TDZ (if present) - bottom impact of the discharge flow - water surface exposure - bank attachment, and other factors. In general, iteration should be conducted in the following order:

- A) Discharge design changes (geometry variations)
- B) Sensitivity to ambient conditions
- C) Discharge flow changes (process variations)

When investigating these variations the CORMIX1 user will quickly appreciate the fact that mixing conditions at short distances

(near-field) are usually quite sensitive and controllable. In contrast, mixing conditions at large distances (far-field) often show little sensitivity unless the ambient conditions change substantially or drastic process variations are introduced.

A) DISCHARGE DESIGN CHANGES (GEOMETRY VARIATIONS): Most of the following recommendations are motivated by the desire of improving conditions in the applicable mixing zones (i.e. minimizing concentrations and/or areal extent).

1) Outfall location: Consider moving the discharge farther offshore to a larger water depth in order to delay flow interaction with the bank and/or surface, and to improve near-field mixing.

2) Height of discharge port: For positively buoyant or neutral discharges it is usually desirable to minimize the port height in order to provide a low submerged jet/plume trajectory. However, if the port height is too small undesirable flow bottom attachment may result. A typical range for port heights is from two to ten diameters. For negatively buoyant discharges, on the other hand, it may be desirable to maximize the port height. Navigational requirements may put further limits on large port heights.

3) Vertical angle of discharge: Near-field dilution for positively or neutrally buoyant discharges is often improved by providing a near-horizontal discharge. In order to prevent bottom interference a slight upward orientation (in the range of +15 to +30 degrees) may be advisable. In contrast, a vertical or near-vertical angle may be favorable for negatively buoyant discharges.

4) Horizontal angle of discharge: This angle provides the discharge orientation relative to the ambient current. A co-flow design (angle of about 0 degrees) or a cross-flow design (about 90 or 270 degrees, respectively) are preferable. A counter-flow design (about

180 degrees) is undesirable from the viewpoint of mixing zone predictability and bottom impacts. Cross-flow designs may be particularly effective in optimizing near-field mixing, and if they are chosen, the port should point in the offshore direction.

5) Port diameter/area (discharge velocity): Remember that for a given discharge flow rate the port area and discharge velocity are inversely related: a small discharge port implies a high discharge velocity, and a consequently high discharge momentum flux. Typically, a high velocity discharge will maximize near-field mixing. Note, however, that high velocity discharges a) may lead to unstable near-field flow configurations perhaps involving undesirable mixing patterns, and b) usually have little, if any, effect on dilutions over the far-field where a LMZ may apply. Discharge velocities in typical engineering designs may range from 3 m/s to 8 m/s. Very high velocities may lead to excessive pumping energy requirements. Very low velocities (less than 0.5 m/s) may lead to undesirable sediment accumulation within the discharge pipe.

B) SENSITIVITY TO AMBIENT CONDITIONS: Variations - of the order of 10 percent - of the following ambient design conditions should be considered: - ambient velocity (or ambient flowrate) - ambient depth (or river/tidal stage) - ambient density structure (notably density differences) Such variability is important for two reasons:

- 1) the usual uncertainty in ambient environmental data,
- 2) the schematization employed by CORMIX1. Please refer to the detailed advice on the specification of environmental data, including the density structure, that is available in program element DATIN. In particular, note the advisory comments on stagnant ambient conditions.

C) DISCHARGE FLOW CHANGES (PROCESS VARIATIONS): Actual process changes can result in variations of one or more of three parameters associated with the discharge: flowrate, density, or pollutant concentration. In some cases, such process changes may be difficult to achieve or too costly. Note, that "off-design" conditions in which a discharge operates below its full capacity also fall into this category.

1) Pollutant mass flux: The total pollutant mass flux is the product of discharge flow (m^3/s) times the discharge pollutant concentration (in arbitrary units). Thus, decreasing the pollutant mass flux will, in general, decrease the resulting pollutant concentration in the near-field and far-field. This occurs, of course, during off-design conditions.

2) Discharge flow: For a given pollutant mass flux, an increase in discharge flow implies an increase in discharge pollutant concentration, and vice versa. For the variety of flow classes contained in CORMIX1 there is no universal rule whether high or low

volume discharges are preferable for optimizing near-field mixing. Mostly, the sensitivity is small, and even more so for far-field effects. Note that a change in discharge flow will influence in turn the discharge velocity and hence momentum flux.

3) Discharge density: The actual density of the discharge flow controls the buoyancy effects relative to the ambient water. Occasionally, the discharge density is controllable through the amount of process heating or cooling occurring prior to discharge. Usually, near-field mixing is enhanced by maximizing the total density difference (positive or negative) between discharge flow and ambient water. In most cases, however, this effect is minor.

You have now completed the analysis of the design case MN-2. At this time you have three options:

- 1) Quit this session of CORMIX1.
- 2) Perform another iteration of CORMIX1 for this general design (You will only change the discharge and mixing zone data bases).
- 3) Perform another iteration of CORMIX1 for this general design (You will only change the mixing zone data base).
- 4) Start another design case (You will enter a complete new data base).

When the next screen appears, choose '8)Quit' option to return to DOS.

NTIS does not permit return of items for credit or refund. A replacement will be provided if an error is made in filling your order, if the item was received in damaged condition, or if the item is defective.

*Reproduced by NTIS
National Technical Information Service
U.S. Department of Commerce
Springfield, VA 22161*

This report was printed specifically for your order from our collection of more than 2 million technical reports.

For economy and efficiency, NTIS does not maintain stock of its vast collection of technical reports. Rather, most documents are printed for each order. Your copy is the best possible reproduction available from our master archive. If you have any questions concerning this document or any order you placed with NTIS, please call our Customer Services Department at (703)487-4660.

Always think of NTIS when you want:

- Access to the technical, scientific, and engineering results generated by the ongoing multibillion dollar R&D program of the U.S. Government.
- R&D results from Japan, West Germany, Great Britain, and some 20 other countries, most of it reported in English.

NTIS also operates two centers that can provide you with valuable information:

- The Federal Computer Products Center - offers software and datafiles produced by Federal agencies.
- The Center for the Utilization of Federal Technology - gives you access to the best of Federal technologies and laboratory resources.

For more information about NTIS, send for our FREE *NTIS Products and Services Catalog* which describes how you can access this U.S. and foreign Government technology. Call (703)487-4650 or send this sheet to NTIS, U.S. Department of Commerce, Springfield, VA 22161. Ask for catalog, PR-827.

Name _____

Address _____

Telephone _____

*- Your Source to U.S. and Foreign Government
Research and Technology.*



44006058