

The VII Corps Artillery in Multi-Domain Operations

A Monograph

by

MAJ Kevin M. Shouse
US Army



School of Advanced Military Studies
US Army Command and General Staff College
Fort Leavenworth, KS

2019

Approved for public release, distribution is unlimited

REPORT DOCUMENTATION PAGE			<i>Form Approved</i> <i>OMB No. 0704-0188</i>		
Public reporting burden for this collection of information is estimated to average 1 hour per response, including the time for reviewing instructions, searching existing data sources, gathering and maintaining the data needed, and completing and reviewing this collection of information. Send comments regarding this burden estimate or any other aspect of this collection of information, including suggestions for reducing this burden to Department of Defense, Washington Headquarters Services, Directorate for Information Operations and Reports (0704-0188), 1215 Jefferson Davis Highway, Suite 1204, Arlington, VA 22202-4302. Respondents should be aware that notwithstanding any other provision of law, no person shall be subject to any penalty for failing to comply with a collection of information if it does not display a currently valid OMB control number. PLEASE DO NOT RETURN YOUR FORM TO THE ABOVE ADDRESS.					
1. REPORT DATE (DD-MM-YYYY) 23-05-2019		2. REPORT TYPE Master's Thesis		3. DATES COVERED (From - To) JUNE 2018– MAY 2019	
4. TITLE AND SUBTITLE The VII Corps Artillery in Multi-Domain Operations			5a. CONTRACT NUMBER		
			5b. GRANT NUMBER		
			5c. PROGRAM ELEMENT NUMBER		
6. AUTHOR(S) Major Kevin M. Shouse			5d. PROJECT NUMBER		
			5e. TASK NUMBER		
			5f. WORK UNIT NUMBER		
7. PERFORMING ORGANIZATION NAME(S) AND ADDRESS(ES) U.S. Army Command and General Staff College ATTN: ATZL-SWD-GD Fort Leavenworth, KS 66027-2301			8. PERFORMING ORG REPORT NUMBER		
9. SPONSORING / MONITORING AGENCY NAME(S) AND ADDRESS(ES) Advanced Military Studies Program			10. SPONSOR/MONITOR'S ACRONYM(S)		
			11. SPONSOR/MONITOR'S REPORT NUMBER(S)		
12. DISTRIBUTION / AVAILABILITY STATEMENT Approved for Public Release; Distribution is Unlimited					
13. SUPPLEMENTARY NOTES					
14. ABSTRACT During WWII and the Persian Gulf War, the US Army synchronized operational fires from the land, air, and maritime domains during Large-Scale Combat Operations. The mechanism was the corps artillery, the single organization with the requisite authority, capability, and capacity to do so. Inadvertently, historical accounts of both conflicts primarily focus on the corps as a whole and do not evaluate the impact of its subordinate corps artillery. Consequently, as the Army prepares to employ Multi-Domain Operations beyond 2028, its operational fires capability is non-existent. Inactivation of the corps artillery to provide manpower for the wars in Iraq and Afghanistan removed all means. Hence, this study conducts a comparison of VII Corps Artillery during LSCO to inform the future of Army multi-domain operational fires. Furthermore, the empirical evidence examined supports this monograph's thesis that peer threats dictate that the Army must establish the Operational Fires Command or expanded corps artillery.					
15. SUBJECT TERMS VII Corps, VII Corps Artillery, Corps Artillery, Operational Fires, Multi-Domain Operations, Large-Scale Combat Operations, World War II, Korean War, Vietnam War, Persian Gulf War					
16. SECURITY CLASSIFICATION OF:			17. LIMITATION OF ABSTRACT	18. NUMBER OF PAGES	19a. NAME OF RESPONSIBLE PERSON
a. REPORT	b. ABSTRACT	c. THIS PAGE			<u>Kevin M. Shouse</u>
(U)	(U)	(U)	(U)	49	19b. PHONE NUMBER (include area code)

Monograph Approval Page

Name of Candidate: MAJ Kevin M. Shouse

Monograph Title: The VII Corps Artillery in Multi-Domain Operations

Approved by:

_____, Monograph Director
Matthew S. Muehlbauer, PhD

_____, Seminar Leader
David A. Meyer, COL

_____, Director, School of Advanced Military Studies
Kirk C. Dorr, COL

Accepted this 23rd day of May 2018 by:

_____, Director, Graduate Degree Programs
Robert F. Baumann, PhD

The opinions and conclusions expressed herein are those of the student author and do not necessarily represent the views of the US Army Command and General Staff College or any other government agency. (References to this study should include the foregoing statement.)

Fair use determination or copyright permission has been obtained for the inclusion of pictures, maps, graphics, and any other works incorporated into this manuscript. A work of the US Government is not subject to copyright, however further publication or sale of copyrighted images is not permissible.

Abstract

The VII Corps Artillery in Multi-Domain Operations by MAJ Kevin M. Shouse, US Army, 49 pages.

During WWII and the Persian Gulf War, the US Army synchronized operational fires from the land, air, and maritime domains during Large-Scale Combat Operations. The mechanism was the corps artillery, the single organization with the requisite authority, capability, and capacity to do so. Inadvertently, historical accounts of both conflicts primarily focus on the corps as a whole and do not evaluate the impact of its subordinate corps artillery. Consequently, as the Army prepares to employ Multi-Domain Operations beyond 2028, its operational fires capability is non-existent. Inactivation of the corps artillery to provide manpower for the wars in Iraq and Afghanistan removed all means. Hence, this study conducts a comparison of VII Corps Artillery during LSCO to inform the future of Army multi-domain operational fires. Furthermore, the empirical evidence examined supports this monograph's thesis that peer threats dictate that the Army must establish the Operational Fires Command or expanded corps artillery.

Contents

Abstract	iii
Acknowledgements	v
Acronyms	vi
Illustrations.....	vii
Introduction	1
The VII Corps Artillery in Action (June - July 1944)	9
The Corps Artillery (1945-1990).....	25
The VII Corps Artillery in the Persian Gulf War (1990-1991)	30
Conclusion.....	41
Bibliography	44

Acknowledgements

I would first like to acknowledge my monograph director Dr. Matthew S. Muehlbauer. His insight, constructive criticism, and guidance was incredibly helpful. I would also be remiss if I failed to acknowledge Seminar Three, led by COL David Meyer. Our dialogue in class, exercises, and activities outside of class were invaluable along the way. Next, I would like to acknowledge the research librarians at CARL, specifically Rusty Rafferty and John Dubuisson. They both helped me tremendously during the archival research process. Lastly, and most importantly, I would like to acknowledge my wife Katherine and two daughters, Sophie and Madeline. Thank you for supporting me throughout this long and arduous process. This monograph is dedicated to the Field Artilleryman of the VII Corps Artillery.

Acronyms

ATACMS	Army Tactical Missile System
DIVARTY	Division Artillery
ETO	European Theater of Operations
FAB	Field Artillery Brigade
HHB	Headquarters & Headquarters Battery
FSCOORD	Fire Support Coordinator
LSCO	Large-Scale Combat Operations
MDO	Multi-Domain Operations
MLRS	Multiple Launch Rocket System
OFC	Operational Fires Command
RGFC	Republican Guard Forces Command
SEAD	Suppression of Enemy Air Defenses
WWII	World War II

Illustrations

Figure 1. The conflict continuum and the range of military operations	2
Figure 2. Operational Fires Command Task Organization.....	6
Figure 3. Cotentin Peninsula, VII Corps Capture of Cherbourg, June 7 - 26, 1944.....	18
Figure 4. VII Corps Artillery Ranges	29
Figure 5. Operation Desert Storm, February 24-28, 1991	32

Introduction

The Navy and Air Force have been projecting power onto the land – supporting ground forces with surveillance, reconnaissance, jamming, fire support, power projection from carriers and air bases, and so on. As I said before, I believe the time has come for our land force to project power from the land onto the other domains and operate seamlessly across shared domains.

—Admiral Harry Harris, May 2016

The US Army cornerstone doctrinal manual, Field Manual (FM) 3-0 *Operations* states, “peer threats generate tactical, operational, and strategic challenges that are an order of magnitude more challenging militarily than those the U.S. Army has faced since the end of the Cold War.”¹ This declaration accentuates the perceived challenges the US Army faces now and in the future. As the US Army refocuses its efforts to defeat adversaries involved in great power competition during Large-Scale Combat Operations (LSCO), numerous challenges exist, as noted in recent comments from senior military leaders.² One contributing gap is the US Army’s capability to deliver operational fires. Reallocation of manpower to the brigade combat team during decades of limited contingency operations in Iraq and Afghanistan removed the means to do so at the corps level.³

¹ US Department of the Army, *Field Manual (FM) 3-0, Operations* (Washington, DC: Government Printing Office, 2017), 1-9.

² Michael Lundy, “Meeting the Challenge of Large-Scale Combat Operations Today and Tomorrow,” *Military Review* (September 2018), accessed October 10, 2018, <https://www.armyupress.army.mil/Journals/Military-Review/English-Edition-Archives/September-October-2018/Lundy-Foreword>.

³ US Department of the Army, *Field Manual (FM) 3-94, Theater Army, Corps, and Division Operations* (Washington, DC: Government Printing Office, 2018), 4-1. The corps is a three-star command employed at either the tactical or operational level of war to integrate land power across the range of military operations. The Army maintains three active duty corps headquarters located at Joint Base Lewis-McChord, WA, Fort Hood, TX, and Fort Bragg, NC.



Figure 1. The Conflict Continuum and the Range of Military Operations. US Department of the Army, *Field Manual (FM) 3-0, Operations* (Washington, DC: Government Printing Office, 2017), 1-1.

Neither the current Army nor joint doctrine provides a quantifiable definition of operational fires. Milan Vego, the foremost expert on the operational level of war, argues “operational fires can be described as the application of one’s lethal and/or nonlethal firepower for generating a decisive impact on the course and outcome of a campaign or major operation.”⁴ Joint doctrine defines a decisive impact as an operational effect created by fires that changes the condition, behavior, or degree of freedom of enemy individuals or systems.⁵ In addition to this doctrinal ambiguity, the Army currently has no permanent fires headquarters above the division level, thus no resourced headquarters to synchronize and employ operational fires for the corps.⁶

To counter current and future peer threats, the *Army Vision* states that the Army must be ready to win in all operating domains (Land, Air, Maritime, Space, Cyber) by 2028.⁷ This goal anticipates the operating environment being more interconnected with an Army role in each

⁴ Milan Vego, *Operational Warfare* (Newport, RI: US Naval War College Press, 2000), 239.

⁵ US Department of the Defense, *Joint Publication (JP) 3-09, Joint Fire Support* (Washington, DC: Government Printing Office, 2014), I-2.

⁶ US Army Field Artillery School, “DIVARTY: A Force Multiplier for the BCT and Division,” Fires Center of Excellence Webpage, April 30, 2014, accessed September 18, 2018, <http://sill-www.army.mil/USAFAS/DIVARTY.html>.

⁷ US Department of the Army, *The Army Vision* (Washington, DC: Government Printing Office, 2018), 1.

domain. In this regard, the Multi-Domain Operations (MDO) concept was created to replace current doctrine and thus facilitate technological procurement and force modernization changes.⁸ A key assumption of the concept regarding peer adversaries is their capability to deny friendly air superiority measures or freedom of maneuver, creating the requirement again for Army ground-based operational fires.⁹ The Operational Fires Command (OFC) is the Army's associated concept to synchronize fires in MDO at the corps, consolidating the functions of joint intelligence, cyberspace, electronic warfare, space, long-range precision fires, and air defense.¹⁰ Further, the OFC is a rebranded corps artillery, unseen in the Army since 2005.

The US Army last employed corps artillery in LSCO in conjunction with AirLand Battle doctrine during the Persian Gulf War. The Desert Storm-era corps artillery provided reinforcing artillery support to subordinate divisions, massed cannon or rocket artillery on deep corps targets, and integrated joint assets within the air, naval, and land domains.¹¹ Commanded by a brigadier general, the corps artillery consisted of a headquarters and headquarters battery (HHB), a field artillery group or brigade containing non-divisional artillery battalions (a mixture of rocket and cannon), and a forward observation capability.¹² The corps artillery served as the single organization with the requisite authority, capability, and capacity to deliver and further synchronize operational fires for the corps writ large.

⁸ Stephen Townsend, "Accelerating Multi-Domain Operations: Evolution of an Idea," Army.mil Webpage, July 23, 2018, accessed November 01, 2018, <https://www.army.mil/article/209492>.

⁹ US Department of the Army, *TRADOC Pamphlet 525-31-1, The U.S. Army in Multi-Domain Operations 2028* (Washington, DC: Government Printing Office, 2018), vii.

¹⁰ Chris Compton and Lewis Boothe, "The Fires Complex, Organizing to Win in Large Scale Combat Operations," *The Fires Journal* (May-June 2018): 4-5.

¹¹ US Department of the Army, *Army Techniques, Tactics, and Procedures (ATTP) 6-22-2, Corps Artillery, Division Artillery, and Field Artillery Brigade Headquarters* (Washington, DC: Government Printing Office, 1993), 1-6.

¹² *Ibid.*, 1-6 – 1-10. A non-divisional artillery battalion is any cannon or rocket battalion subordinate to a field artillery brigade or group, therefore not assigned to a division artillery.

The Army leadership ordered the removal of the corps artillery force structure during modularization to provide manpower for additional brigade combat teams deploying to Iraq and Afghanistan.¹³ This decision removed the Army's ability to synchronize and employ operational fires. Moreover, common practice has become to dismantle the five remaining active duty field artillery brigades or FABs (formerly the field artillery group) to support subordinate Division Artillery (DIVARTY) operations; non-divisional field artillery battalions subordinate to the brigade are usually task-organized directly under a DIVARTY, which per current doctrinal tasks generate tactical effects.¹⁴ This resourcing decision is due to the DIVARTY table of organization & equipment not including a single delivery asset (cannon or rocket), dissimilar to DIVARTY that took part in preceding LSCO. The FABs reduction of subordinate artillery battalions therefore reduces the corps commander's ability to generate operational effects against the enemy corps echelon Integrated Fires Command.¹⁵ Further, the resourcing decision reduces the corps ability to shape deep for subordinate divisions.

In addition to the dismantling of the FABs subordinate non-divisional field artillery battalions, doctrinal ambiguity exists regarding the role of its headquarters. According to Field Manual (FM) 3-09 *Field Artillery Operations and Fire Support*, "the FAB (commanded by a colonel) is normally attached to a division."¹⁶ However, the 17th FAB, 18th FAB, and 75th FAB

¹³ Boyd Dastrup, *Artillery Strong: Modernizing the Field Artillery for the 21st Century* (Fort Leavenworth, KS: Combat Studies Institute Press, 2018), 113.

¹⁴ US Department of the Army, *Army Technical Publication (ATP) 3-94.2, Deep Operations* (Washington, DC: Government Printing Office, 2016), A-3.

¹⁵ US Department of the Army, *Training Circular (TC) 7-100.2, Opposing Force Tactics* (Washington, DC: Government Printing Office, 2011), 2-3. The primary target for the field artillery brigade is the enemy Integrated Fires Command or IFC. The IFC is a combination of a standing C2 structure and task organization of artillery and integrated air defense. Division and above have IFCs, below brigade does not; US Department of Defense, Joint Staff, *Joint Publication (JP) 3-0, Joint Operations* (Washington, DC: Government Printing Office, 2018), I-3. The IFC is integral to an adversary's Anti-Access/Area-Denial or A2/AD strategies designed to disrupt operations across the operating domains. A2 capabilities limit an adversary from entering an area of operations, while AD capabilities restrict its freedom of action.

¹⁶ US Department of the Army, *Field Manual (FM) 3-09, Field Artillery Operations and Fire Support* (Washington, DC: Government Printing Office, 2014), 1-35.

are currently aligned (not assigned) to I Corps, XVIII Airborne Corps, and III Corps respectively. Serving in the role of Corps Force Field Artillery Headquarters (when available), the FAB staff provides guidance to the small preexisting corps fires cell (led by a lieutenant colonel) on how to best synchronize FAB assets (radars and rocket artillery only) to support the corps concept of fires.¹⁷ The two additional active duty FABs are not aligned to a corps, while the remainder in the National Guard (not all containing rocket artillery) are placed sporadically under various divisional control.¹⁸

In comparison to the FAB, the OFC is conceived as a permanent corps fires headquarters, designed to leverage the combined capability of a FAB and Air Defense Artillery Brigade with sensors, intelligence, non-lethal expertise, and joint assets (figure 2).¹⁹ Thus, the OFC possesses what the FAB lacks, the integrating functions of an assigned headquarters capable of streamlining multi-domain operational effects. Further, the OFC is designed with the capability to strike targets beyond 500 kilometers or the Fire Support Coordination Line. A vital task per the MDO concept, Long Range Precision Fires enables windows of opportunity for airpower through the striking of enemy air defenses deep.²⁰ Essential to the OFC's utility, the commander (brigadier general) requires expanded authorities beyond those of the FAB to synchronize and employ multi-domain operational fires.

The subordinate functions and authorities of the OFC either do not exist anymore or are spread across the corps staff and FAB. But integrating operational fires in accordance with the

¹⁷ US Army, *FM 3-09* (2014), Glossary-8. A Force Field Artillery Headquarters is the senior field artillery headquarters assigned to a command, organized to synchronize field artillery asset employment.

¹⁸ Active and National Guard Field Artillery Units, *The Fires Center of Excellence Online Redbook*, accessed February 24, 2019, <http://sill-www.army.mil/firesbulletin/archives/2019/jan-feb/articles/article-5.pdf>.

¹⁹ Compton and Boothe, "The Fires Complex, Organizing to Win in Large Scale Combat Operations," 5.

²⁰ *Ibid.*, 4-5; US Joint Staff, *JP 3-09* 2014, GL-7. The Fire Support Coordination Line or FSCL separates fires of the land or amphibious force commander from adjacent commands in an area of operations. The FSCL is commonly used to delineate airspace and targeting between the land and air components.

MDO concept requires a devoted headquarters with assigned forces. Consequently, the OFC force-design update, or FDU, expands the former corps artillery structure to contain a joint capable headquarters, signal company, observation battery (counterfire radar and remotely piloted aircraft), ICEWS Company (Intelligence, Cyber, Electronic Warfare, Space), intact FAB (one or more), and Air Defense Artillery Brigade.²¹ Subordinate formations will provide the OFC the ability to kill the enemy Integrated Fires Command, enable freedom of maneuver for airpower, deliver deep joint fires, and mass reinforcing fires for subordinate divisions as executed by corps artillery during previous LSCO.

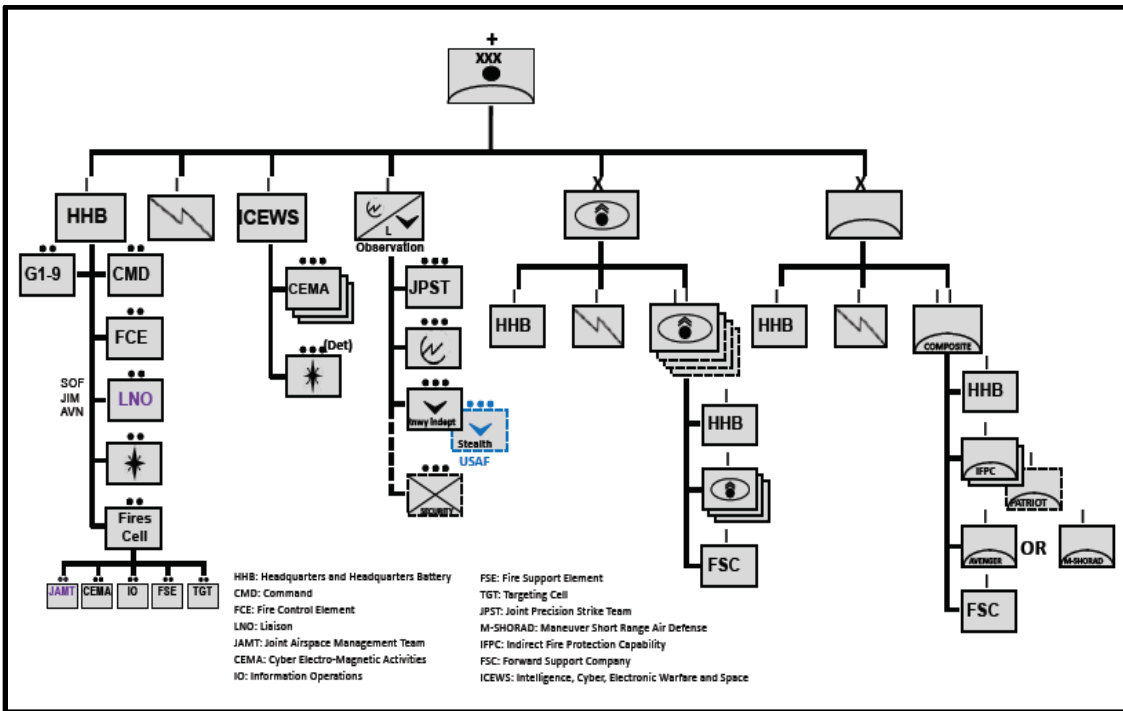

Figure 2. Operational Fires Command Task Organization. Chris Compton and Lewis Boothe, “The Fires Complex, Organizing to Win in Large Scale Combat Operations” *The Fires Journal* (May-June 2018): 4.

This monograph will scrutinize historical cases to demonstrate the effectiveness of corps-directed operational fires across the domains (multi-domain) during LSCO. Though such a

²¹ Compton and Boothe, “The Fires Complex, Organizing to Win in Large Scale Combat Operations,” 5.

methodology is not new, the preponderance of monographs published after the doctrinal adaptation of the operational level focus primarily on the need to doctrinally define operational fires, illuminate theoretical connections, or simply display its importance.²² Connecting military theory with historical case studies is not enough, as the Army needs quantifiable solutions to deliver operational fires at the corps in support of MDO. Therefore, this monograph utilizes historical analysis of corps artillery actions during LSCO to prove or disprove the need to establish the Operational Fires Command.

To the author's knowledge, no published literature exists that explicitly examines the effectiveness of the corps artillery in LSCO for generating multi-domain effects with operational fires. To this end, the monograph will analyze the crucial role VII Corps Artillery fulfilled in managing land, air, and naval operational effects during World War II (WWII) and the Persian Gulf War. The VII Corps is the subject of various books, chapters, articles, and monographs but remarkably not its subordinate corps artillery. Among the numerous publication on the VII Corps, *Jayhawk! The VII Corps in the Persian Gulf War* by Dr. Stephen A. Bourque is the foremost work. Though his manuscript details the general actions of the corps' operations in the war, this monograph will concentrate more on the raw power – and command – of the VII Corps Artillery, and provide the context to appreciate changes between WWII, Desert Storm, and the contemporary operating environment.

The next chapter will consider the VII Corps Artillery from June 6, 1944, to July 31, 1944, specifically during Operation Neptune or Normandy Landings, the reduction of the

²² William Rice, "Operational Fires – What's In A Name?" (Monograph, School of Advanced Military Studies, US Army Command and General Staff College, 1990). For more information on Operational Fires, see Lincoln Ward, "The Division Artillery: Linking Strategy to Tactics" (Monograph, School of Advanced Military Studies, US Army Command and General Staff College, 2017); Alex Aquino, "Force Structure Matters: The US Field Artillery in Operational Art" (Monograph, School of Advanced Military Studies, US Army Command and General Staff College, 2015-01); Keith Gordon, "Field Artillery: Lending a Touch of Class at the Operational Level" (Monograph, School of Advanced Military Studies, US Army Command and General Staff College, 1989); Robert Novotny, "Defining Operational Fires" (Monograph, Naval War College, 2006).

Cherbourg defenses, and Operation Cobra or the Normandy Breakout. The following chapter will begin with a discussion of the limited role of the corps artillery in both the Korean and Vietnam conflicts, and outline the doctrinal, technological, and organizational changes to the function of the corps artillery between 1945 and 1990. The subsequent chapter examines the operational impact of VII Corps Artillery during the Persian Gulf War. The monograph will conclude by assessing these case studies and the subsequent dismantling of the corps artillery after 2005 to address the Army's future path regarding multi-domain operational fires.

The monograph includes research material attained from the archives at the Eisenhower Presidential Library in Abilene, KS and Ike Skelton Combined Arms Library at Fort Leavenworth, KS. Significant collections include the J. Lawton Collins Papers for VII Corps actions in WWII and the Richard Swain and Robert Scales Papers for operations in the Persian Gulf War. However, limited access to VII Corps Artillery WWII daily operational summaries inhibited the inquiry, as did the ongoing classification of official records on VII Corps Artillery actions in the Persian Gulf War. Hence the argument relies solely on available official documents and secondary sources. The expansive and disjointed history of the US Army pursuing LSCO in different times and areas does not lend itself to a holistic analysis of corps artillery and operational fires; VII Corps Artillery operations during WWII and the Persian Gulf War offer the best examples.

The concept of the operational level of war did not enter doctrine or the common lexicon until well after WWII. For the purposes of the monograph, operational fires are those which achieve a decisive operational effect on a campaign or major operation. Example targets include command & control infrastructure, theater logistics, Anti-Access/Area-Denial capability, operational reserves, or a decisive point that which alters adversarial operational maneuver or campaign plan. Contemporary operational fires are inherently joint and therefore achieve effects

in all five domains. However, the focus for this monograph is operational effects generated in the land, maritime, and air domain only. The current classification of operations in the space and cyber domains lies outside of the scope of the monograph. The provided definition of operational fires and following universal criteria are therefore the mechanism to measure the operational effects of the corps artillery.

This monograph utilizes five criteria intertwined in all historical accounts to examine positive trends or drawbacks regarding corps artillery employment. These include the commander, staff, functions, integration, and resources. The corps artillery staff enabled the commander or fire support coordinator (FSCOORD) to visualize and further synchronize operational fires for the corps. In conjunction with joint assets, the function of the corps artillery must be centralized massed fires at the decisive point. As described, these criteria or threads are inherently connected and thus further gauge the flexibility, responsiveness, and adaptability of the corps artillery in LSCO. While warfare with associated technology drastically differed between 1944 and 1991, these measures do not change and consistently impacted how the corps artillery operated in both conflicts.

The VII Corps Artillery in Action (June - July 1944)

The VII Corps first entered service in August 1918, assigned to the First Army for operations in France during World War I. But the signing of the German Armistice in November sent the corps home for demobilization after no influential combat action. VII Corps was reactivated in 1940 at Fort McClellan, AL, and participated in the famous Louisiana Maneuvers before movement to Great Britain in preparation for the invasion of Europe.²³ Throughout operations in Normandy, MG J. Lawton “Lightning Joe” Collins served as its commander, the

²³ Stephen Bourque, *Jayhawk! The VII Corps in the Persian Gulf War* (Washington, DC: Center of Military History, 2002), 5-15.

favorite corps commander of GEN Eisenhower.²⁴ His earlier experiences as a division commander at Guadalcanal in the Pacific Theater of Operations proved beneficial during the joint amphibious planning for Operation Neptune.²⁵

The VII Corps artillery activated at Fort Sill, Oklahoma, in 1943 under BG Williston B. Palmer.²⁶ By the time it arrived in Britain for the D-Day invasion, it consisted of 5,716 Soldiers spread throughout the HHB, 13th Observation Battalion, 142nd Field Artillery Group, and 188th Field Artillery Group.²⁷ Fort Sill was home to the Army's field artillery branch, where corps artillery staff officers learned field artillery doctrine and tactics. Topics included ammunition management, communication with air and naval leadership, the positioning of field artillery groups, artillery support to adjacent corps, synchronization of artillery intelligence, and training plans.²⁸ Senior artillery commanders learned how to function in their role of the FSCOORD or primary artillery advisor to the corps commander, as well as how to work within the special staff to disseminate orders to subordinate DIVARTY commanders.²⁹

BG Palmer likewise completed his training at Fort Sill in preparation for corps artillery command in the European Theater of Operations (ETO). The future Vice Chief of Staff of the Army quickly created a reputation for demanding a high standard of performance for all his

²⁴ John Wilson, *Armies, Corps, Divisions, and Separate Brigades, Army Lineage Series* (Washington, DC: US Army Center of Military History, 1987), 341.

²⁵ Omar Bradley, *A Soldier's Story* (New York: Holt Publishing, 1951), 227-228.

²⁶ Headquarters VII Corps Artillery, VII Corps, *European Theater of Operations After Action Review, 30 July 1944*, file VII Corps Artillery After-Action Review June 6, 1944 – May 9, 1945, folder N122982, Ike Skelton Combined Arms Research Library, Fort Leavenworth, KS, 1.

²⁷ G-3 Section, Headquarters VII Corps, *Operation Neptune Troop List*, United States Army Command and General Staff College, Battle Analysis: D-Day, Course P651, Vol. 1, Part 1, Ike Skelton Combined Arms Research Library, Fort Leavenworth, KS, 2.

²⁸ Boyd Dastrup, *Cedat Fortuna Peritis, A History of the Field Artillery School* (Fort Leavenworth, KS: Combat Studies Institute Press, 2012), 112-113.

²⁹ War Department, Chief of Staff, *Field Manual (FM) 6-100, Tactics and Technique of Division Artillery and Higher Artillery Echelons* (Washington, DC: Government Printing Office, 1944), 36-37.

subordinates.³⁰ He served as commander of the corps artillery for the preponderance of the war and was awarded the Army Distinguished Service Medal for his actions.³¹ His excellent working relationship with MG J. Lawton Collins likewise proved critical for the corps' to succeed in the bloody campaigns after D-Day. Collins expressed his appreciation of BG Palmer's expert counsel and command in his farewell message published in the *Field Artillery Journal* after the war:

With the cessation of hostilities in this theater, I wish to express to you and to the officers and men of the VII Corps Artillery my great admiration and appreciation for their outstanding performance in support of the Corps in the European campaign. From D-day onward, the VII Corps Artillery was distinguished by its exceptional aggressiveness. All units were guided by the determination to give fire support whenever and wherever required and to reach the vital targets whatever the difficulties... In our enthusiasm for the great part played by our air force, particularly the fighter-bombers, we must not lose sight of the magnificent support given our infantry by the artillery, which was always ready with its fire, night or day, fair or foul weather. The great superiority of our artillery gave us a tremendous edge on the Germans.³²

In preparation for D-Day, the June 6, 1944 invasion of Axis-occupied Europe, VII Corps Artillery would have used the 1944 version of Field Manual 6-20, *Tactical Employment of Artillery*. It delineated how to conduct missions including naval fire support synchronization, artillery-intelligence, air-artillery cooperation, centralized counterfire, and reinforcing fires for subordinate divisions; all of which VII Corps Artillery conducted in the weeks after D-Day.³³ Moreover, whereas the 1941 version of FM 6-20 task-organized the preponderance of corps artillery resources to reinforce subordinate DIVARTY, the 1944 version did not. It emphasized

³⁰ Frederic Brown, "Spearhead, The Story of the 3rd Armored Division Artillery," *The Fires Journal* (September 1946): 507.

³¹ The Hall of Valor Project Webpage, "Williston B. Palmer," accessed December 11, 2018, <https://valor.militarytimes.com/hero/100340>.

³² Lawton Collins, "Tribute to Artillery," *The Fires Journal* (September 1946): 525.

³³ War Department, Chief of Staff, *Field Manual (FM) 6-20, Tactical Employment of Field Artillery* (Washington, DC: Government Printing Office, 1944), 1-3, 9, 22, 34-35. An artillery unit with a reinforcing mission receives calls for fire directly from the subordinate artillery unit whose fires it is tasked to reinforce.

centralized artillery at the corps to mass, which proved vital for generating operational effects.³⁴

Period naval doctrine contradicted centralization of fires, as individual ships commanders were emboldened to engage land targets at their discretion. This technique for synchronizing naval fire support was not ideal as ships of the era did not possess the requisite communications to maintain situational awareness and ability to mass, therefore generate operational effects.³⁵ But naval doctrine did mandate joint integration between field artillery and naval fire support assets during an amphibious assault. US Navy Field Training Publication (FTP) 167 *Landing Operations Doctrine* stated, “field artillery available in a landing operation will usually be less than in a land warfare operation on a corresponding scale. This factor may require ships' guns to continue certain fire missions during all or a large part of the operation. Careful coordination of field artillery and ships gunfire is required.”³⁶ As VII Corps prepared for the amphibious assault on Utah Beach, corps and field army artillery leadership identified the need for pre- and post-landing naval fire support or joint fires. As such, planners from both VII Corps Artillery and the bombardment force conducted joint planning to synchronize its future employment.

Subordinate to First Army, VII Corps’ three operational objectives upon invading Normandy was to secure a beachhead on the Cotentin Peninsula, establish contact with V Corps on its left, and subsequently seize the industrial port of Cherbourg.³⁷ VII Corps combat power included three infantry and two airborne divisions. The 4th Infantry “Ivy” Division was designated

³⁴ War Department, Chief of Staff, *Field Manual (FM) 6-20, Tactical Employment of Field Artillery* (Washington, DC: Government Printing Office, 1941), 72.

³⁵ Christopher Young, *Gators of Neptune, Naval Amphibious Planning for the Normandy Invasion* (Annapolis MD: Naval Institute Press, 2006), 216.

³⁶ US Department of the Navy, *Field Training Publication (FTP) 167, Landing Operations Doctrine* (Washington, DC: Government Printing Office, 1938), 130-131.

³⁷ G-3 Section, Headquarters VII Corps, *Capture of Cherbourg and Cotentin Peninsula AAR, 23 July 1944*, United States Army Command and General Staff College, Battle Analysis: D-Day, Course P651, Vol. 1, Part 3, Ike Skelton Combined Arms Research Library, Fort Leavenworth, KS (hereafter referred to as VII Corps Invasion AAR), 1.

to lead VII Corps' landing on French soil at Utah Beach, to the right of V Corps.³⁸ Further tasked to linkup inland with the airborne divisions to secure the lodgment, the Ivy Division would depend on joint fires to destroy Wehrmacht defensive capabilities and corresponding artillery.

VII Corps Artillery's first task became coordinating naval fire support or joint fires with Task Force U Bombardment Group.³⁹ Arranged around the 14-inch guns of the battleship *U.S.S. Nevada*, the group's eighteen ships rehearsed for months to deliver joint fires on the German defenders at Utah Beach.⁴⁰ According to Joint Publication (JP) 3-09 *Joint Fire Support*, joint fires "are fires delivered during the employment of forces from two or more components in coordinated action to generate desired effects in support of a common objective."⁴¹ Based on the flagship *U.S.S. Tuscaloosa*, and in conjunction with bombardment group commander Rear Admiral Morton Deyo's staff, VII Corps Artillery planners used aerial intelligence to identify over fifty pre-landing joint targets for destruction including artillery positions, pillboxes, machine-gun emplacements, and air defenses.⁴² The joint planning effort, likewise, ordered continuous naval fire support and air support, as senior leaders identified Utah Beach as the most hazardous of the five allied landing sites.⁴³ The plan further detailed that once preparatory fires were complete, the VII Corps Artillery S-3, LTC Fred Campbell, was responsible for synchronizing fires with targets identified by Shore Fire Control Party (observers) and aircraft.⁴⁴

³⁸ G-3 Section, Headquarters VII Corps, *VII Corps Utah Area Simplified Buildup Priority List*, United States Army Command and General Staff College, Battle Analysis: D-Day, Course P651, Vol. 1, Part 1, Ike Skelton Combined Arms Research Library, Fort Leavenworth, KS, 5.

³⁹ Headquarters VII Corps Artillery, VII Corps, *European Theater of Operations After Action Review*, 3 August 1944, file VII Corps Artillery After-Action Review June 6, 1944 – May 9, 1945, folder N122982, Ike Skelton Combined Arms Research Library, Fort Leavenworth, KS (hereafter cited as VII Corps Artillery 3 August AAR), 2.

⁴⁰ Young, *Gators of Neptune*, 163-165.

⁴¹ US Joint Staff, *JP 3-09* 2014, vii.

⁴² Young, *Gators of Neptune*, 163-165, 190-191.

⁴³ Joseph Balkoski, *Utah Beach, The Amphibious Landing and Airborne Operations on D-Day* (Mechanicsburg, PA: Stackpole Books, 2005), 219.

⁴⁴ VII Corps Artillery 3 August AAR, 2.

The German defenses in Normandy, dubbed the Atlantic Wall, relied on a series of strong points with integrated obstacles and artillery to defeat the Allied invasion force on the beach. Field Marshall Erwin Rommel commanded Army Group B and the Normandy region.⁴⁵ Allied intelligence accurately assessed Rommel's defensive plan, mandating operational security to maintain the element of surprise. Surprise was necessary to mitigate the risk of prematurely triggering the employment of the Panzer counterattack forces under Hitler's personal control.⁴⁶ The Utah Beach sector of Rommel's defense consisted of one strong point at La Madeleine in contrast to the twelve on Omaha Beach. Likewise, the terrain behind the beach defenses was flat unlike the towering cliffs on Omaha. The strong point did include a formidable 88mm cannon, antitank guns, 75mm cannons, mortars, and multiple machine guns. A mixture of the Wehrmacht 709th Division, 716th Division, and a Georgian Battalion totaling over 12,000 men defended the area.⁴⁷ The German defensive measures dictated US planners delineate by ship what targets the bombardment group would engage. The *U.S.S. Nevada* would focus deep on the Wehrmacht artillery followed by general support missions, while the destroyers targeted the strong point, corresponding trench network, and beach itself before the 0630 landing.⁴⁸

Simultaneous to the pre- and post- landing naval bombardment, the Army Air Corps conducted shaping operations against Wehrmacht beach defenses and inland artillery. The Allies had attained air superiority in the months leading up to the invasion, therefore, the Luftwaffe

⁴⁵ Theodore Gatchel, *At the Water's Edge, Defending against the Modern Amphibious Assault* (Annapolis, MD: Naval Institute Press, 1996), 65-68.

⁴⁶ Stephen Ambrose, *D-Day, June 6, 1944: The Climactic Battle of World War II* (New York: Simon & Schuster, 1994), 22.

⁴⁷ *Ibid.*, 112-113; Ian Hogg, *Artillery in Color, 1920-1963* (New York: Arco Publishing, 1980), 183. The 88-mm gun was the primary German heavy artillery system during WWII. It was used in both an indirect fire and air-defense role as described later in the monograph during Operation Cobra. The max range of the system was 17,497 meters or 35,000 feet.

⁴⁸ War Department, Chief of Staff, United States Forces European Theater, "Report on Study of Field Artillery Operations," 1945, 12.

posed little resistance.⁴⁹ Issued on April 8th, the Joint Fire Plan signed by all component commanders dictated the targets destroyed by airpower prior to and during the invasion. The Twenty-First Army Group as the higher headquarters of VII Corps was responsible for the synchronization of airpower across the two domains. The Ninth Air Force was subsequently tasked to support VII Corps operations at Utah Beach, focusing their firepower on Widerstandsneest Five (strong point) or the defenses at La Madeline.⁵⁰ Due to air planning residing at the group echelon, the VII Corps Artillery was not responsible for the synchronization or employment of airpower.

Prussian strategist Helmuth von Moltke observed, “no plan of operation extends with certainty beyond the first encounter with the enemy’s main strength.”⁵¹ Due to a steady three-knot southeasterly current and poor visibility, Navy coxswains delivered the bulk of the 4th Infantry Division 2,000 yards south of their intended landing zones.⁵² This drastic change triggered the VII Corps Artillery leadership to immediately shift fires to support the infantry at the new landing zone. At the request of MG Collins per the guidance of BG Palmer, *Nevada* immediately traversed her 14-inch guns to fire point blank and penetrate the seawall at the new landing point. The effect of the guns were felt by the men advancing towards the beach in Higgins boats (who swore the vacuum from the guns caused the boats to lift out of the water), and effectively neutralized the German positions at the new landing site.⁵³ The remnants of the defending Wehrmacht 919th Regiment (subordinate to the 709th Division) were so battered by the pre-

⁴⁹ Center of Military History Staff, *Normandy, The U.S. Army Campaigns of World War II* (Washington, DC: Center of Military History, 1972), 19.

⁵⁰ Stephen Bourque, *Beyond the Beach, The Allied War Against France* (Annapolis, MD: Naval Institute Press, 2018), 210, 219.

⁵¹ Daniel Hughes, *Moltke On the Art of War, Selected Writings* (New York: Random House, 1993), 45.

⁵² Craig Symonds, *Operation Neptune, The D-Day Landings and the Allied Invasion of Europe* (New York: Oxford University Press, 2016), 271.

⁵³ Ambrose, *D-Day, June 6, 1944*, 295-297.

landing bombardment that the lead units from the 4th Infantry Division only received sporadic small arms fire.⁵⁴ Utah Beach was secured two hours later, allowing the 4th Infantry Division to quickly push inland and link up with the 101st Airborne Division.⁵⁵

The exceedingly successful amphibious assault on Utah Beach was not without shortcomings. The pre-landing naval bombardment was not long enough. To achieve surprise, VII Corps only received forty-minutes to conduct preparatory fires. Operational planners assumed a prolonged bombardment would prompt the commitment of Hitler's operational reserves against the landing forces.⁵⁶ This planning assumption prevented the *U.S.S. Nevada's* bombardment from effectively destroying inland Wehrmacht artillery casemates or bunkers before the assault; it would be many more days until the Navy silenced the German artillery batteries harassing men unloading supplies on Utah Beach. Moreover, the problem was exacerbated with the change in landing location, requiring VII Corps Artillery to focus on new targets before completing fires on those prioritized on the original target list. Therefore, the primary effect of the bombardment was neutralization fires, not destruction fires – and subsequent analysis indicated that neutralization fires would not have been sufficient if the 4th Infantry Division landed at their intended location.⁵⁷

In contrast to the naval doctrine of the period, centralized control of naval fire support greatly assisted the assault. The Task Force U Bombardment Group and VII Corps Artillery staffs synchronized operational fires for the first time from one central location (*U.S.S. Tuscaloosa*).⁵⁸ This command and control decision enabled rapid visualization and further synchronization of

⁵⁴ Ambrose, *D-Day, June 6, 1944*, 306-308.

⁵⁵ Balkoski, *Utah Beach*, 219-221; US Department of the Defense, Joint Staff, *Joint Publication (JP) 1-02, Department of Defense Dictionary of Military and Associated Terms* (Washington, DC: Government Printing Office, 2016), 142. A lodgment is a designated area that when seized makes the continuous landing of troops and materiel possible and provides maneuver space for follow on operations.

⁵⁶ Young, *Gators of Neptune*, 207-209.

⁵⁷ *Ibid.*, 207-208; US Army, *FM 6-20* (1944), 5. Neutralization fires are delivered on enemy personnel thus causing severe losses and interrupting movement or action. Neutralization is established by delivering surprise fire in intense masses.

⁵⁸ *Ibid.*, 216.

operational fires as events unfolded. Problems persisted however, with the coordination between naval fire support and air support/observation. Centralization of all air operations in Uxbridge, England at the Army-Air Headquarters decreased response time and the rapid synchronization of air support, thus limiting its usefulness in support of ground forces. This restrictive command and control structure further affected the ability of air spotters in the chaos of the invasion to adjust naval fire support and complicated airspace deconfliction of the ordinance delivered between ships and aircraft.⁵⁹

The amphibious assault on Utah Beach hinged on the interoperability between the VII Corps Artillery and the naval bombardment force.⁶⁰ Joint, operational fires nullified German defenses and facilitated First Army and VII Corps' establishing a lodgment in Normandy.⁶¹ Though coordinated through unequal methods, these missions were vital, for the air and naval bombardment served as the primary means of fires for the 4th Infantry Division during the amphibious assault. Once ashore several hours after the beach was secure, the 4th Division's DIVARTY with organic tactical fires assets started to support the advancing infantry and armor regiments.

The next notable victory for VII Corps artillery was the strategic seizure of Cherbourg.⁶² On D+1 MG Collins initiated a twenty six-day campaign, ordering his divisions to advance along exterior lines of communication to cut the Cotentin Peninsula and converge on the vital deep-water port (figure 3).⁶³ Field Marshall Rommel knew the importance of the Cherbourg port but

⁵⁹ Young, *Gators of Neptune*, 209-211.

⁶⁰ Sam Tangredi, *Anti-Access Warfare, Countering A2/AD Strategies* (Annapolis, MD: Naval Institute Press, 2013), 141.

⁶¹ VII Corps Invasion AAR, 2.

⁶² James Carafino, *After D-Day, Operation Cobra and the Normandy Breakout* (Boulder, CO: Lynne Rienner Publishers, 2000), 85.

⁶³ VII Corps Invasion AAR, 7.

did not possess the requisite combat power to conduct more than a delaying action.⁶⁴ With Allied intelligence reporting a large quantity of German artillery in Cherbourg, MG Collins' would require a plan to centralize counterfire operations to mitigate the threat to his advancing armor and infantry divisions approaching the city.

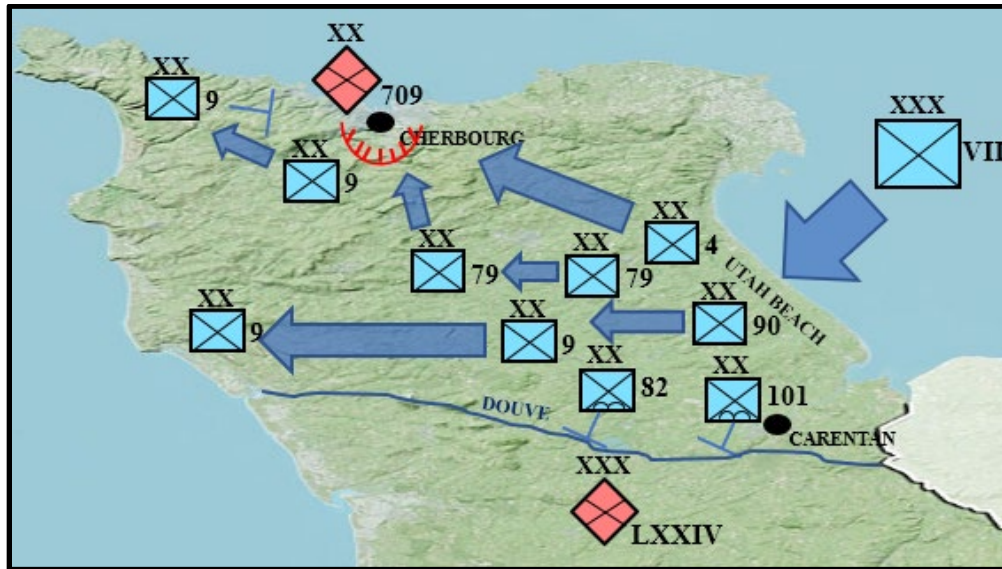

Figure 3. Cotentin Peninsula, VII Corps Capture of Cherbourg, June 7 - 26, 1944. *Source:* Created by author. Adapted from Gordon A. Harrison, *United States Army in World War II: The European Theater of Operations, Cross-Channel Attack* (Washington, DC: Center of Military History, 1993), Map XXIV, XXIII, XXIV.

BG Palmer and his staff landed at Utah Beach on June 7th, establishing the corps artillery headquarters just inland. A small contingent of the staff remained aboard the *U.S.S. Tuscaloosa* to continue coordination of naval fire support with fleet operations along the Cotentin Peninsula.⁶⁵ At the conclusion of D+2, all field artillery battalions attached to VII Corps Artillery completed their preparations to support combat operations.⁶⁶ The corps fire direction center subsequently landed on June 12th, establishing voice communications with the five subordinate DIVARTY and

⁶⁴ Russell Weigley, *Eisenhower's Lieutenants, The Campaign of France and Germany, 1944-1945* (Bloomington, IN: Indiana University Press, 1981), 142.

⁶⁵ Samuel Morison, *History of United States Naval Operations in World War II, Volume XI* (Boston, MA: Atlantic Monthly Press, 1984), 195-197.

⁶⁶ VII Corps Artillery 3 August AAR, 2.

two field artillery groups to form the fires communication network. Due to the vast distances between divisions and range limitations of era heavy artillery, BG Palmer quickly attached the preponderance of his non-divisional artillery battalions from the field artillery groups to the subordinate DIVARTY.⁶⁷

Summarized in the August 1944 edition of the *Fires Journal*, corps artillery must keep artillery battalions under centralized control to support the corps writ large by massing at the decisive point.⁶⁸ Similarly the military theorist Antione Henry Jomini stated that a commander must throw the mass of his forces upon the decisive point to the overthrow the enemy.⁶⁹ To generate an operational effect at a decisive point, corps artillery planners at times utilized the AWIFM planning tool. The acronym stood for adequate support for “committed combat units, weight the main effort, immediately available FA support for the commander to influence the action, facilitate future operations, and maximum feasible centralized control.”⁷⁰ All five fundamentals emphasize centralized employment to mass the corps artillery in support of the main effort and/or corps writ large.

BG Palmer’s task-organization decision for this part of the campaign contradicted this rule, but out of operational necessity. The dispersed nature of operations across the Cotentin Peninsula, and the similar ranges between the non-divisional cannon battalions and of those in the DIVARTY, demanded he temporarily disperse the corps artillery to support the latter.⁷¹ This

⁶⁷ VII Corps Artillery 3 August AAR, 2. Fire Direction Center: the nucleus of the field artillery, serves as the central headquarters from within artillery support is generated.

⁶⁸ D. S. Sommerville, “Corps and Non-Divisional Artillery,” *The Fires Journal* (August 1944): 516-520; Joint Staff, *JP 1-02* 2018, 142. A decisive point is a geographic place or key event that when acted upon allows commanders to gain an advantage over an adversary.

⁶⁹ Antione Henry Jomini, “The Art of War,” in *Roots of Strategy Book #2*, 389-557. (Harrisburg, PA: Stackpole Books, 1987), 461.

⁷⁰ US Army, *ATTP 6-22-2* (1993), 1-6.

⁷¹ Boyd Dasturp, *King of Battle, A Branch History of the U.S. Army’s Field Artillery School* (Fort Monroe, VA: United States Army Training and Doctrine Command, 1992), 237. The max range of the 155mm M1 Howitzer is 14,950 meters, and the 8-inch Howitzer is 16,925 meters. These howitzers did not provide the ability for the corps artillery to fire long range thus enable depth in corps operations.

command decision provided maximum flexibility, adaptability, and responsiveness to subordinate division commander's ostensible requests for increased firepower against the German defenders. Though the corps artillery headquarters and observation battalion itself played a minor role at this stage, they became crucial once the corps reconsolidated and commenced the reduction of the Cherbourg port defenses on June 18th.

After the subordinate divisions of VII Corps encircled Cherbourg, the mission of the VII Corps Artillery transitioned to centralized counterfire support. Counterfire is defined as, "fire intended to destroy or neutralize enemy weapons. Includes counterbattery and countermortar fire."⁷² The task was a high priority since Wehrmacht defenses in the medieval fortress city consisted of a large density of long-range artillery.⁷³ The VII Corps Artillery hence needed to mass on individual strong points in sequence to reduce the operational risk to the corps attack. To manage counterfire missions, the VII Corps Artillery relied on the 13th Observation Battalion.

The 13th Observation Battalion's primary purpose was to detect enemy artillery positions.⁷⁴ The organization consisted of an HHB and two batteries operating sound and flash bases.⁷⁵ This then-revolutionary equipment identified the location of enemy artillery through analysis of muzzle flashes and recorded acoustics, which preceded the counterfire radars used today. The data from the bases was then passed forth to the counterbattery section in the corps fire direction center or joint headquarters for action.⁷⁶ BG Palmer ensured the battalion focused on finding the estimated twenty artillery casemate positions supporting the strong points manned

⁷² US Joint Staff, *JP 3-09* 2014, GL-7.

⁷³ G-3 Section, Headquarters VII Corps, *Capture of Cherbourg and Cotentin Peninsula After-Action Review, 6 June – 1 July 1944*, United States Army Command and General Staff College, Battle Analysis: D-Day, Course P651, Vol. 1, Part 3, Ike Skelton Combined Arms Research Library, Fort Leavenworth, KS, 6.

⁷⁴ War Department, Chief of Staff, United States Forces European Theater, "Study of the Organization and Equipment of Field Artillery Units," 1945, 59.

⁷⁵ *Ibid.*, 28.

⁷⁶ US Army, *FM 6-100* (1944), 35.

by the 40,000 defenders of the Wehrmacht 709th Division. MG Collins deemed further joint fires essential, which were again coordinated through LTC Campbell and his small staff aboard the *U.S.S. Tuscaloosa*.⁷⁷

After a week of effective counterfire support (18-25 June), a massive naval bombardment force closed on Cherbourg to aid in the final destruction of Wehrmacht artillery batteries around Cherbourg. Consisting of three battleships and support ships, the task force immediately came under heavy German artillery fire. This reaction unintentionally assisted the 13th Observation Battalion in locating and engaging the remaining Wehrmacht artillery positions.⁷⁸ The muzzle flashes and acoustics of the German artillery systems were easily identifiable by forward observers and the observation battalion. Once located, the guns of the VII Corps Artillery went into action. As the VII Corps After-Action Review states, “the infantry supported by artillery and mortar fire reduced one strong point after another.”⁷⁹ In due course, the effectiveness of counterfire support in conjunction with infantry assaults overwhelmed the beleaguered German defenders resulting in their surrender the following day.⁸⁰

VII Corps Artillery learned numerous positive lessons from its first month of combat in France. First, because of range constraints of the cannon systems, the corps artillery commander had to be flexible in his task organization, concentrating or dispersing non-divisional heavy artillery battalions among divisions as required by the mission. Second, the use of corps artillery liaisons worked well with the fleet to establish and maintain cross-domain synergy amongst the two services. Lastly, the observation battalion’s ability to locate German artillery positions proved decisive against the Wehrmacht artillery. In contrast to missions requiring high concentration of artillery assets, the DIVARTY were doctrinally employed to deliver close fire

⁷⁷ Morison, *History of United States Naval Operations in World War II*, 195-197.

⁷⁸ *Ibid.*, 195-196.

⁷⁹ VII Corps Invasion AAR, 6.

⁸⁰ VII Corps Artillery 3 August AAR, 2.

support to the advancing infantry and armor formations, such as during the approach to Cherbourg – whereas at the port itself, centralized control of field artillery for counterfire purposes in conjunction with naval assets helped defeat the German 709th Division.

Once Cherbourg was secure, VII Corps began preparations to expand the Allies' lodgment by breaking the stalemate to the south. Though the Allies made significant headway in capturing Cherbourg, progress farther south was agonizingly slow. The *bocage*, a mixture of dense woods, hedgerows, and open fields, favored the prepared Wehrmacht defenders. First Army's operational tempo in June and July was agonizingly slow, with daily progress measured in yards at the cost of thousands of casualties.⁸¹ Likewise, the British farther to the east failed to capture Caen in Operation Goodwood despite significant losses.⁸² To penetrate the German line in the American sector, First Army Field Order #6, dubbed Operation Cobra, ordered four US Corps to simultaneously attack abreast, with VII Corps identified as the main effort west of Saint Lô. VII Corps task organization included five divisions and dedicated air support to assist in blowing a path through the German line for further exploitation.⁸³

Recognizing the adverse effects of the restricted terrain, GEN Omar Bradley mandated a massive aerial bombardment for Operation Cobra.⁸⁴ Integrated planning between First Army, VII Corps, and the IX Tactical Air Force, commanded by MG Quesada, sequenced the bombing with artillery for suppression of enemy air defense (SEAD).⁸⁵ The VII Corps Artillery liaisons inside

⁸¹ Mark Calhoun, "Close Air Support and Bombardment Theory: Operation Cobra," in *Lethal and Non-lethal Fires, Historical Case Studies of Converging Cross-Domain Fires in Large-Scale Combat Operations*, 163-182. (Fort Leavenworth, KS: Army University Press, 2018), 172.

⁸² Martin Blumenson, *Breakout and Pursuit* (Washington, DC: Center of Military History, 1993), 185.

⁸³ G-3 Section, Headquarters VII Corps, *The History of the VII Corps U.S. Army, Covering Operations in Normandy, France, From 1-31 July 1944, Chapter 3, Operation Cobra*, United States Army Command and General Staff College, Battle Analysis: D-Day, Course P651, Vol. 1, Part 3, Ike Skelton Combined Arms Research Library, Fort Leavenworth, KS (hereafter cited as VII Corps Cobra AAR), 23.

⁸⁴ Blumenson, *Breakout and Pursuit*, 214.

⁸⁵ VII Corps Cobra AAR, 23; Mark Calhoun, "Close Air Support and Bombardment Theory," 169. MG Quesada was a favorite of Eisenhower, an experienced leader who understood the role of bomber aircraft to support the actions of soldiers on the ground.

the IX Tactical Air Force Headquarters therefore established cross-domain synergy for operational fires prior to the plans initial delivery to LTG Collins on July 12th. Postponed on July 24th due to weather and fratricide, the mission went forward the following day.⁸⁶

BG Williston B. Palmer personally coordinated the execution of the Counter Flak Plan or SEAD mission on July 25th. According to joint doctrine, SEAD is “activity that neutralizes, destroys, or temporarily degrades surface-based enemy air defenses by destructive and/or disruptive means.”⁸⁷ The mission was designed to destroy the preponderance of Wehrmacht anti-aircraft positions that lay in the path of the heavy bombers and attacking divisions. Though short on ammunition, the Wehrmacht LXXXIV Corps air defenses and artillery posed a severe threat to the American bombers and ground forces.⁸⁸ MG Palmer, therefore, beginning on July 20th, directed the VII Corps Artillery to conduct continuous counter-battery surveillance with the 13th Observation Battalion. This task was deemed essential to identify the preponderance of Wehrmacht anti-aircraft positions along the VII Corps front.⁸⁹ MG Collins and BG Palmer understood that the survivability of the bombers relied on the timely and accurate fires of the VII Corps Artillery.

For this mission, VII Corps Artillery task-organization included 550 artillery pieces including 134 pieces of heavy caliber artillery consisting of the M1 155mm and 8-inch cannon battalions. This massive capability did not include the mutually supporting fires from the other corps’ abreast. To mass such a large force, subordinate field artillery groups were task-organized under the 32nd FAB, which was specially designed to command and control large amounts of non-

⁸⁶ Carafino, *After D-Day*, 110-111. Casualties of the fratricide incident on July 24th included 100 US VII Corps Soldiers and LTG Leslie McNair, the highest-ranking American casualty of the war.

⁸⁷ US Department of the Defense, Joint Staff, *Joint Publication (JP) 3-01, Countering Air and Missile Threats* (Washington, DC: Government Printing Office, 2017), GL-14.

⁸⁸ Blumenson, *Breakout and Pursuit*, 191. The Wehrmacht LXXXIV Corps possessed the formidable dual-purpose 88mm gun which could simultaneously engage Allied aircraft and armor formations in direct fire mode.

⁸⁹ VII Corps Cobra AAR, 23.

divisional artillery battalions.⁹⁰ The brigade significantly streamlined fire mission processing to mass on the German positions. The subordinate DIVARTY focused on fire support for the subsequent infantry and armor assaults across the hedgerows once the bombers created the seam in the German line.

Forty minutes prior to MG Quesada's bombers arriving over their targets, the VII Corps Artillery again unleashed its raw destructive power. Due to the timely acquisitions from the 13th Observation Battalion, VII Corps Artillery quickly silenced the preponderance of Wehrmacht anti-aircraft positions along the 6,000-yard corps front, resulting in the loss of only five allied bombers with fifty nine damaged. German air defense units opened fire as soon as they spotted the approaching US bombers, with half of the estimated 250 systems destroyed in seconds. Within the initial minutes of the barrage, German commanders told the remaining positions to cease-fire to survive the onslaught.⁹¹

The VII Corps Artillery received 138,298 projectiles to support Operation Cobra, with the preponderance fired during the Counter-Flak Plan and the early hours of fighting.⁹² As a result, First Army relied on airpower for operational fires for the remainder of the successful five-day operation. The VII Corps Artillery headquarters immediately transitioned to implementing deconfliction measures (airspace clearance procedures) with the Air Force vice synchronizing operational effects. MG Collins subsequently stated, "if artillery ammunition had been unrestricted, all commanders would have fired considerably more, and their initial advance would probably have been faster and our own casualties less."⁹³ Even with persistent ammunition shortages, the successful destruction of enemy air defenses enabled airpower to create an

⁹⁰ Carafino, *After D-Day*, 101.

⁹¹ *Ibid.*, 112.

⁹² VII Corps Cobra AAR, 39.

⁹³ William Cosgrove, *Time on Target: The 945th Field Artillery Battalion in World War II* (William Cosgrove III, 1997), 68.

operational effect or window of opportunity to be further exploited by the columns of American armor and infantry.

The VII Corps Artillery continued to serve in the campaigns to liberate France, Belgium, and Germany, and distinguished itself at the Battle of the Falaise Pocket, the liberation of Aachen, and Ardennes Campaign. It fired its last rounds on April 30, 1945 and would not see combat again until forty six years later.⁹⁴ In the interim, VII Corps Artillery was deactivated in the Army until 1986, when it was reestablished in Western Europe to counter Soviet aggression in the context of NATO's preparations for potential war under the doctrine of AirLand Battle.⁹⁵ It was not until the First Gulf War that the corps artillery would truly command operational fires in a multiple-domain environment.

The Corps Artillery (1945-1990)

Corps artillery served a minimal role in the Korean War. Shortages of ammunition, trained artillery battalions, and available field artillery group headquarters inhibited operations. The 5th Field Artillery Group, the only one of its kind during the war, controlled an ad-hoc arrangement of over nineteen battalions for the ROK II Corps. This command support relationship was satisfactory during static operations, but its capacity was not increased to synchronize fires during offensive operations in Korea's mountainous terrain.⁹⁶ Moreover, evaluations of American artillery during the war revealed an insufficient number of non-divisional artillery battalions, observation battalions, and field artillery groups.⁹⁷ The shortfall in field artillery force structure required corps artillery headquarters to command the few available

⁹⁴ Headquarters VII Corps Artillery, VII Corps, *European Theater of Operations After Action Review, 8 June 1945*, file VII Corps Artillery After-Action Review June 6, 1944 – May 9, 1945, folder N122982, Ike Skelton Combined Arms Research Library, Fort Leavenworth, KS, 1.

⁹⁵ Janice McKenney, *The Organizational History of the Field Artillery, 1775-2003* (Washington, DC: Center of Military History, 2010), 16.

⁹⁶ *Ibid.*, 200-201.

⁹⁷ US Army, Eighth Army, Artillery Officer, "A Study of the Employment and Effectiveness of the Artillery With the Eighth Army During the Period October 1951-July 1953" (Seoul, Korea, 1954), 2-3.

non-divisional artillery battalions, a mission requiring an intermediary field artillery group headquarters. More broadly, this critical shortfall prohibited the synchronization and massing of fires across the shared domains, therefore limiting the operational impact of Army fires in combination with joint assets.

Tactically, however, the war demonstrated the applicability of the artillery for SEAD, counterfire, and close fire support missions. These missions were particularly important a decade later in Vietnam, as well as during other conflicts that did not involve significant LSCO.⁹⁸ Therefore, it was essential for the field artillery to establish new ways of employing fires, as the war in Vietnam relegated the corps artillery and multi-domain operational fires less vital than decentralized tactical fire support. Counterinsurgency operations, for example, required light artillery operating under a DIVARTY in noncontiguous battles from static positions or firebases. Correspondingly, light or smaller caliber artillery was preferred by maneuver commanders in Vietnam over the larger caliber non-divisional artillery battalions due to their limited mobility in jungle terrain and inability to be transported by helicopter.⁹⁹ The 1st Cavalry Division pioneered air assault operations with artillery at the Battle of Ia Drang in 1965 to extend their ranges.¹⁰⁰ The technique known as an artillery raid is still used today and proved decisive in a different form during the Persian Gulf War. Conversely, the only campaigns that utilized a corps artillery headquarters were Operation Junction City and Cedar Falls. The II Field Force, Vietnam Artillery, synchronized fourteen artillery battalions supporting two American and one South Vietnamese Division in these early LSCO that were not pursued by US forces later in the war.¹⁰¹

⁹⁸ McKenney, *The Organizational History of the Field Artillery*, 205.

⁹⁹ *Ibid.*, 271-272.

¹⁰⁰ Dastrup, *King of Battle*, 281.

¹⁰¹ Bernard Rogers, *Cedar Falls- Junction City: A Turning Point* (Washington, DC: Center for Military History, 1989), 120.

Quickly after the conclusion of the war, Army leadership developed doctrine to pursue large-scale combined arms warfare against potential Warsaw Pact aggression in Western Europe.¹⁰² This transformation reestablished the role of corps artillery in Army doctrine and force structure, particularly in the context of the operational level of war. This concept did not exist in American doctrine until the publication of the 1982 version of Field Manual (FM) 100-5, *Operations*. The watershed document defined the operational level of war as the theory of large unit operations during campaigns, including conventional fires in depth – which identified the requirement for long-range or deep fires to facilitate operational maneuver.¹⁰³ The operational concepts drew upon the Soviet idea of ‘deep operations’ which was first developed in the 1920’s and 1930s.¹⁰⁴ But it also reflected more recent observations of the 1973 Yom Kippur War, specifically regarding the expanding physical nature of the battlefield.¹⁰⁵

Beyond defining the operational level of war, FM 100-5 of 1982 established AirLand Battle as the Army’s official doctrine. This in turn refuted the doctrine of Active Defense from the 1976 version of the manual.¹⁰⁶ Whereas Active Defense stressed the reduced US Army capability to wage war after Vietnam, and the technological overmatch attained by the Soviets over NATO forces, AirLand Battle adopted a more aggressive approach to defending Western Europe.¹⁰⁷ To defeat Soviet fires and maneuver, it called for initiative, agility, synchronization, and depth – with the latter being synonymous with deep battle or deep attack by operational fires. The effect of deep battle was intended to isolate, immobilize, and weaken defenders in-depth,

¹⁰² John Romjue, *From Active Defense to AirLand Battle: The Development of Army Doctrine, 1973-1982* (Washington, DC: US Government Printing Office, 1984), 2.

¹⁰³ US Department of the Army, *Field Manual (FM) 100-5, Operations* (Washington, DC: Government Printing Office, 1982), 2-3.

¹⁰⁴ Georgii Isserson, *The Evolution of Operational Art* (Fort Leavenworth, KS: Combat Studies Institute Press, 2013), X, XVI.

¹⁰⁵ US Army, *FM 100-5 (1982)*, 7-13.

¹⁰⁶ Benjamin King, *Victory Starts Here: A 35-year History of the US Army Training and Doctrine Command* (Fort Leavenworth: KS, Combat Studies Institute Press, 2009), 32.

¹⁰⁷ Romjue, *From Active Defense to AirLand Battle*, 3-8.

allowing the US Army to conduct combined-arms maneuver against a weakened Soviet ground force.¹⁰⁸

The 1988 version of Field Manual (FM) 6-20, *Fire Support in the AirLand Battle* would have served as the regulation for corps artillery during the Persian Gulf War. According to the document, “fire support assets that will be used at the operational level include Air Force support providing air interdiction and battlefield air interdiction as well as field artillery providing long-range rocket and missile fires.”¹⁰⁹ The US Army, fortunately, identified the need for extended range rockets and missiles during the preceding decade, as the only available assets to conduct deep operations during the 1970s and early 1980s were fixed-wing aircraft that belonged to the Air Force. MG David Ott, as Field Artillery School Commandant (1973-1976), persuaded Army leadership to prioritize funding for the systems, thereby revamping the artillery after Vietnam. Furthermore, MG Ott mandated centralization of artillery back under corps artillery control.¹¹⁰

Not until the arrival of MLRS and the linked Army Tactical Missile System (ATACMS) could the Army indeed employ deep fires. MLRS was fielded between 1983 and 1990, and a welcome addition for the Field Artillery Branch which had long requested a mobile rocket platform to deeply engage enemy indirect fires and air defenses. MLRS was a tracked artillery system that delivered either the ATACMS or a myriad of conventional rocket variants. Once fully integrated, both MLRS with rockets and ATACMS replaced cannon battalions as the deep hammer of the field artillery group or brigade. One MLRS launcher could deliver the same amount of firepower as twenty-eight 8-inch howitzers employed by the VII Corps Artillery in

¹⁰⁸ US Army, *FM 100-5* (1982), 7-2.

¹⁰⁹ US Department of the Army, *Field Manual (FM) 6-20, Fire Support in the AirLand Battle* (Washington, DC: Government Printing Office, 1988), 1-7.

¹¹⁰ Dastrup, *Artillery Strong*, 11. MG Ott championed deep fires in support of AirLand Battle. Likewise, he enforced centralization of non-divisional artillery support back under corps artillery control, as directed in the 1976 version of Field Manual 6-20, *Fire Support in Combined Arms Operations*.

Normandy.¹¹¹ A crew of three could rapidly fire twelve standard rockets to a range of thirty kilometers, which increased with the acquisition of the ATACMS munition. The latter, still in the inventory today, is the Army's primary surface-to-surface missile system with a range beyond 300 kilometers (figure 4).¹¹² ATACMS was first utilized in combat during the Persian Gulf War against Iraqi surface to air missiles, operational logistics, long-range rocket artillery, and corps command & control nodes, demonstrating that Army corps now possessed the capability to extend the battlefield to generate effects at the operational level of war.¹¹³

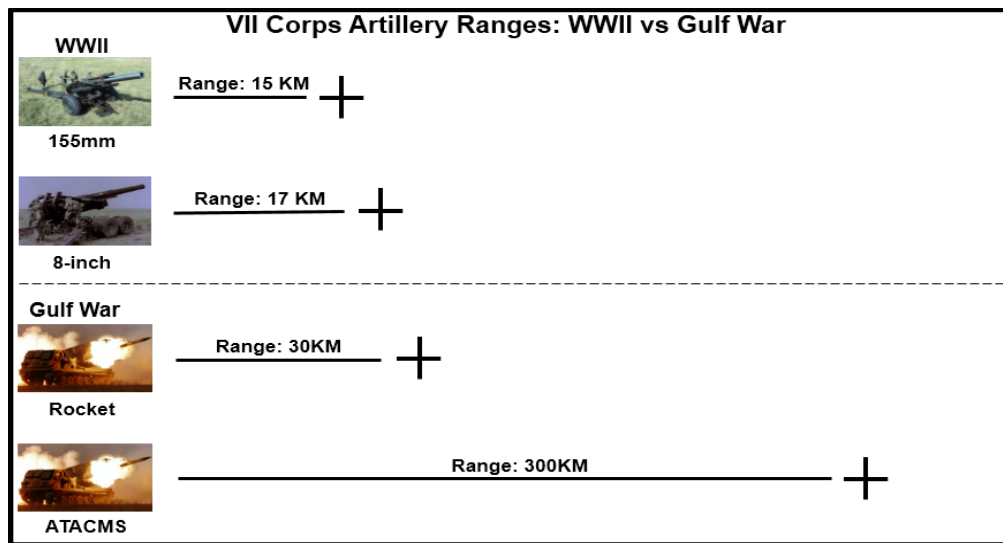

Figure 4. VII Corps Artillery Ranges. *Source:* created by author. Adapted from US Department of the Army, *Field Manual (FM) 3-09 Field Artillery Operations and Fire Support* (Washington, DC: Government Printing Office, 2014), 2-24; Boyd Dastrup, *King of Battle, A Branch History of the U.S. Army's Field Artillery* (Fort Monroe, VA: US Army Training and Doctrine Command, 1992), 237.

Organizationally, the corps artillery structure changed little in the forty seven-years between WWII and the Persian Gulf War. The VII Corps Artillery table of organization & equipment in 1991 consisted of an HHB, multiple FABs, and a corps target acquisition

¹¹¹ McKenney, *The Organizational History of the Field Artillery*, 291.

¹¹² US Army, *FM 3-09* (2014), 2-24.

¹¹³ VII Corps Artillery Persian Gulf War AAR, 48-51.

detachment or CTAD. The CTAD replaced the observation battalion sound and flash bases with new counterfire radar technology.¹¹⁴ Equipped with both the AN/TPQ-36 (countermortar) and larger AN/TPQ-37 (counterartillery) radars, the CTAD could electronically execute the role of the WWII era observation battalion with greater speed and accuracy beyond a range of seventy kilometers.¹¹⁵ Both versions of artillery radar played a significant role during artillery raids and counterfire operations against the overwhelming Iraqi artillery during the Persian Gulf War.

The VII Corps Artillery in the Persian Gulf War (1990-1991)

Operation Desert Storm concluded with a clear victory for the US-led coalition. Executed between January-February 1991, the short campaign validated AirLand Battle doctrine and corresponding new technology for the US Army. The 100-hour ground campaign equally washed away the stigma of defeat in Vietnam from the mind of American citizens.¹¹⁶ Americans watching the war on their TV screens, witnessed repeated striking images of rockets firing through the night's sky. Little did they know, but they were observing the raw destructive power of VII Corps Artillery with the newly acquired Multiple Launch Rocket System (MLRS). The Persian Gulf War was a triumph for corps artillery after decades of neglect.

Earlier, on August 2, 1990, the 1.1 million-man Iraqi Army had invaded Kuwait, quickly overwhelming its small, ill-equipped military, and giving Saddam Hussein control of its oil resources. In response, on August 7th US President George H.W. Bush deployed the 82nd Airborne Division to Saudi Arabia to defend it against any further aggression. On January 17, 1991, the day after the United Nations Security Council's deadline for Saddam Hussein's forces

¹¹⁴ US Army, *ATTP 6-22-2* (1993), 1-6 – 1-10.

¹¹⁵ McKenney, *The Organizational History of the Field Artillery*, 291.

¹¹⁶ Robert Scales, *Certain Victory: The United States Army in the Gulf War* (Fort Leavenworth, KS: US Army Command and General Staff College Press, 1994), 358-361.

to withdraw from Kuwait expired, the US launched one hundred Tomahawk cruise missiles into Iraq and Kuwait to begin Operation Desert Storm.¹¹⁷ But it would be another month before the US and its coalition partners attained the requisite combat power in Saudi Arabia to take offensive ground action to expel Saddam's forces.

The VII Corps became one of two Army corps participating in the invasion under 3rd US Army (Army Central) totaling 333,000 Soldiers.¹¹⁸ The 146,000 soldiers of the Jayhawks commanded by LTG Fred Franks received the call for forward deployment on November 8, 1990.¹¹⁹ Subsequent orders on November 13, 1990, tasked VII Corps with finding and destroying the Republican Guard Forces Command (RGFC) in Kuwait, with a start point inside Saudi Arabia, east of the XVIII Airborne Corps (see figure 5).¹²⁰ Desert Storm was expected to be a tough campaign as Iraq possessed the fourth largest army in the world to include a considerable amount of artillery.¹²¹

¹¹⁷ Headquarters 42nd Field Artillery Brigade, VII Corps Artillery, *42nd FA BDE Desert Storm After-Action Review*, File 918752, Volume 17C, VII Corps Artillery, Gulf War Collection, Ike Skelton Combined Arms Research Library, Fort Leavenworth, KS, 1.

¹¹⁸ Richard Swain, *"Lucky War" Third Army in Desert Storm* (Fort Leavenworth, KS: US Army Command and General Staff College Press, 1994), 349.

¹¹⁹ Scales, *Certain Victory*, 133-134.

¹²⁰ Bourque, *Jayhawk!*, 31.

¹²¹ Theresa Kraus and Frank Schubert, *The Whirlwind War: The United States Army in Operations Desert Shield and Desert Storm* (Washington, DC: Government Printing Office, 1995), 133-134.

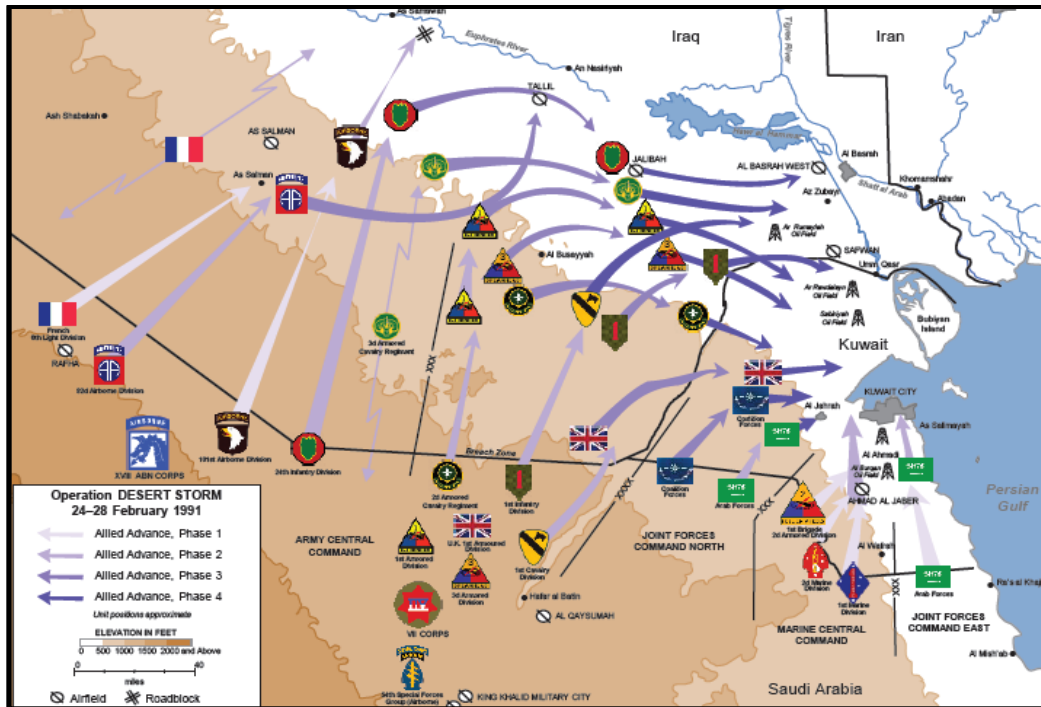

Figure 5. Operation Desert Storm, February 24-28, 1991. Boyd Dastrup, *Artillery Strong: Modernizing the Field Artillery for the 21st Century* (Fort Leavenworth, KS: Combat Studies Institute Press, 2018), 7.

On January 13, 1991, VII Corps published OPLAN 1900-2 dubbed Operation Dark Saber to its subordinate divisions.¹²² The operation consisted of five phases; deployment of forces to theater, preparation of the battlefield, breach and penetration of the Iraqi VII Corps, defeat of the Iraqi VII Corps reserves, and destruction of the RGFC.¹²³ To accomplish its mission, the VII Corps task-organization included five armored divisions, an armored cavalry regiment, aviation brigade, and the VII Corps Artillery.¹²⁴ Though initially disorganized, the corps arrived in Saudi Arabia as scheduled, and was in place by mid-January. A significant factor in this successful deployment was the air campaign executed through mid-January, whose strategic objective was

¹²² Bourque, *Jayhawk!*, 38-39.

¹²³ Headquarters VII Corps Artillery, VII Corps, *Annex D, Corps OPLAN 1990-2, Operation Desert Saber*. File 917795. Volume 17C, VII Corps Artillery, Gulf War Collection, Ike Skelton Combined Arms Research Library, Fort Leavenworth, KS. (hereafter cited as VII Corps Artillery Annex D), D-1 – D-2.

¹²⁴ Bourque, *Jayhawk!*, 37.

to deter Saddam Hussein from attacking Saudi Arabia, thus providing time for coalition building and concentration of necessary combat power.¹²⁵

The VII Corps Artillery had reactivated in May 1986 to wage deep battle against the Soviets in Western Europe.¹²⁶ BG Creighton W. Abrams Jr., son of the celebrated commander of American forces in Vietnam, was selected to command the corps artillery as well as serve as corps FCSOORD during the war.¹²⁷ BG Abrams' task-organization included the 42nd FAB, 75th FAB, 142nd FAB, and 210th FAB. The 210th FAB deployed organically with the VII Corps Artillery from Germany, while the remaining FABs – based in the US – were attached upon arrival to Saudi Arabia.¹²⁸ The four brigades, comprised of twelve battalions, contained a mixture of the new MLRS and upgraded cannon battalions (155mm/8-inch).¹²⁹ BG Abrams served as the commander of the VII Corps Artillery and corps FSCOORD until its inactivation shortly after the war. The former head of the Combined Arms and Services Staff School at Fort Leavenworth, KS, BG Abrams was a soldier scholar and a tremendous builder of teams. In the days before the invasion, he required DIVARTY commanders and corps artillery staff officers to confront their one-to-one force ratio with Iraqi artillery and develop ways to overcome it.¹³⁰ More broadly, he fostered a shared understanding of the problem amongst leaders at all levels in the corps artillery, developing trust between new teammates and rapidly establishing standard operating procedures that became paramount for success.¹³¹

¹²⁵ Bourque, *Jayhawk!*, 71.

¹²⁶ Janice McKenney, *Army Lineage Series, Field Artillery Part I* (Washington, DC: Center of Military History, 2010), 16.

¹²⁷ Scales, *Certain Victory*, 201.

¹²⁸ VII Corps Artillery Persian Gulf War AAR, 20.

¹²⁹ Bourque, *Jayhawk!*, 469.

¹³⁰ *Ibid.*, 109.

¹³¹ Scales, *Certain Victory*, 200-207.

The only tasks or missions explicitly assigned for operational fires per contemporary AirLand Battle doctrine included “campaign J-SEAD [joint SEAD], the joint attack of the second echelon [joint fires on deep enemy maneuver], and the conduct of deep operations by fire support.”¹³² VII Corps Artillery relied on the precision of MLRS rockets and ATACMS, synchronized with the air campaign, to accomplish these missions and extend its operational depth. It also employed more traditional heavy cannon systems to provide reinforcing fires for subordinate divisions and counterfire. In addition, air liaisons with accompanying information systems allowed BG Abrams’ headquarters to synchronize artillery and airpower; the VII Corps Artillery planned 245 deep targets for destruction with airpower throughout the war (this total does not include on-call tactical Air Force support for the close fight).¹³³ In addition to allocated air support, BG Abrams maintained control of deep Apache helicopter strikes during artillery raids.¹³⁴ All told, control of these assets enabled VII Corps Artillery to coordinate and direct joint fires, and particularly the land and air domains, to generate crucial operational effects in support of Desert Storm.

The VII Corps Artillery mission in *Annex D (Joint Fires)* was to “synchronize lethal and non-lethal fire support systems in support of VII Corps’ attack to destroy the republican guard.”¹³⁵ The Republican Guard Forces Command (RGFC) was deemed by senior Army leadership as the enemy operational center of gravity due to their fighting capability and extreme loyalty to the regime.¹³⁶ But the VII Corps Artillery would not engage the RGFC until the final

¹³² US Army, *FM 6-20 (1989)*, 1-7.

¹³³ Headquarters VII Corps Artillery, VII Corps, *Desert Storm Standard Operating Procedures, Part 1*. File 947460. Volume 17C, VII Corps Artillery, Gulf War Collection, Ike Skelton Combined Arms Research Library, Fort Leavenworth, KS, B-4-3.

¹³⁴ VII Corps Artillery Persian Gulf War AAR, 75-76, 88.

¹³⁵ VII Corps Artillery Annex D, D-1.

¹³⁶ Thomas A. Kearney and Eliot A. Cohen, *Gulf War Air Power Survey Summary Report*, (Washington, DC: Government Printing Office, 1993), 40; US Joint Staff, *JP 1-02* 2018, 29. The COG is the source of power that provides moral or physical strength to an adversary.

days (26-27 February) of the campaign since they were initially out of range. VII Corps Artillery thus divided the corps campaign order between “prep the battlefield” actions which included deep ATACMS employment and artillery raids, and the subsequent ground campaign. The one hundred-hour ground campaign consisted primarily of VII Corps Artillery support to the 1st Infantry Division for breach and counterfire operations against the RGFC. To generate operational effects against the Iraqi Army throughout both phases, the VII Corps Artillery employed 55,214 cannon rounds, 10,456 rockets, twenty five ATACMS, and thousands of bombs.¹³⁷

During the “prep the battlefield” phase, the VII Corps was consolidated at TAA Juno just south of the Kuwait border. The proximity to a potential Iraqi spoiling attack, Scud launchers, and long-range artillery increased the operational risk for the corps.¹³⁸ The threat mandated the VII Corps Artillery headquarters to immediately plan, execute, and assess ATACMS employment for the first time. On January 18, 1991, A Battery, 6th Battalion, 27th Field Artillery fired SEAD with ATACMS in support of B-52 bomber aircraft – VII Corps Artillery’s first combat mission since WWII.¹³⁹ Over the next month, MLRS battalions in the corps artillery conducted similar missions to engage Iraqi air defenses, rocket artillery, and command and control nodes totaling twenty one missions. All nominated targets required approval by the corps commander due to the finite number of the new missiles in the theater, with battle damage assessment benefitting from interoperability with the Air Force – particularly the assignment of Army personnel to Joint Surveillance Target Acquisition Radar (JSTARS) aircraft.¹⁴⁰

¹³⁷ VII Corps Artillery Persian Gulf War AAR, 20.

¹³⁸ Bourque, *Jayhawk!*, 129.

¹³⁹ Dastrup, *Artillery Strong*, 2.

¹⁴⁰ Bourque, *Jayhawk!*, 129.

In addition to employing MLRS deep from TAA Juno, BG Abrams' fires plan directed deep fires to destroy the Iraqi VII Corps artillery.¹⁴¹ The Iraqi VII Corps was the first unit the Jayhawks would fight, consisting of seven divisions and one artillery brigade with 588 systems.¹⁴² Its artillery consisted primarily of towed howitzers with ranges capped at 27,000 kilometers, but it nevertheless posed a serious threat to the subsequent advance of American armor and infantry.¹⁴³ These Iraqi artillery regiments were some of the most professional in Saddam's Army, and were expected to fight to the death.¹⁴⁴ BG Abrams tasked his four FABs, in close coordination with airpower, to destroy 90% of the artillery from positions inside Saudi Arabia beginning on February 17, 1991.¹⁴⁵ To achieve this objective, cross-domain synergy between the Air Force and VII Corps was again deemed a necessity.

Limited numbers of ATACMS required BG Abrams and the corps artillery to employ and synchronize other means to provide operational fires, including airpower and MLRS artillery raids.¹⁴⁶ These raids were similar to those developed in Vietnam, whereby artillery infiltrated forward to extend range; the MLRS were too heavy for helicopter transport, though, and moved under their own power.¹⁴⁷ However, these units benefitted from Q-36 and Q-37 radar, as well as Global Positioning Systems (GPS).¹⁴⁸ The former entailed the threat of destructive counterfire that, at this stage in the war, most Iraqi troops did not wish to endure.¹⁴⁹ As for GPS, it allowed

¹⁴¹ VII Corps Artillery Annex D, D-7.

¹⁴² VII Corps Artillery Persian Gulf War AAR, 37.

¹⁴³ Bourque, *Jayhawk!*, 161.

¹⁴⁴ Scales, *Certain Victory*, 201.

¹⁴⁵ VII Corps Artillery Persian Gulf War AAR, 133.

¹⁴⁶ *Ibid.*, 75.

¹⁴⁷ Dastrup, *King of Battle*, 282-283.

¹⁴⁸ Bourque, *Jayhawk!*, 161.

¹⁴⁹ Creighton Abrams, "The Gulf War and European Artillery," Association of the United States Army Webpage, January 20, 2015, accessed December 11, 2018, <https://armyhistory.org/the-gulf-war-and-european-artillery>, 5. Due to overwhelming fear of destruction by airpower and artillery, the Iraqi VII Corps Artillery did not engage their counterfire radars, thus ceded the counterfire fight early.

MLRS battalions to stealthily infiltrate into enemy territory, fire, and quickly displace after each mission. According to BG Abrams on GPS, “it did not just tell us where we were, it did so in terrain where the other side had no idea where they were.”¹⁵⁰ The Iraqi artillery was no match for the Jayhawk MLRS – counterfire radar team. VII Corps Artillery and subordinate DIVARTY fired over 14,000 cannon rounds and 4,900 MLRS rockets between 17 January and 23 February.¹⁵¹

The deep strikes with ATACMS and artillery raids, in combination with air power, had a devastating effect on the Iraqi Army during the “prep the battlefield” period. The combination of Air Force fixed-wing aircraft, Apaches, the Q-37 radar, ATACMS, and MLRS quickly validated deep operations doctrine before the ground battle even began on G-Day. The corps artillery synchronized operation destroyed 50% of the Iraqi VII Corps reserves, 73% of its artillery, and disrupted command & control with forward units. Numerous Iraqi tank and artillery crews deserted *en masse*, fearful of devastating US firepower. The time had now come, however for the VII Corps Artillery to transition to offensive operations, commencing at 0400 hours on February 24, 1991, with the 1st Infantry Division breach.¹⁵²

Having accomplished all “prep the battlefield” tasks per *Annex D*, the Jayhawks shifted focus to defeating the Iraqi VII Corps defense. During his initial visit to Saudi Arabia in late 1990, the Third Army and VII Corps staffs notified LTG Franks on the Iraqis’ plan to extend barriers and defensive networks across the planned VII Corps axis of advance.¹⁵³ This reality demanded a division-executed, and corps-reinforced, combined-arms breach to create a gap in the Iraqi defenses. To accomplish this high-risk operation at the recognized operational decisive point, LTG Franks chose the 1st Infantry “Big Red One” Division as the main effort due to its

¹⁵⁰ Abrams, “The Gulf War and European Artillery,” 6.

¹⁵¹ *Ibid.*, 28-31.

¹⁵² *Ibid.*, 38-42.

¹⁵³ Bourque, *Jayhawk!*, 191-192.

recent history perfecting such operations at the National Training Center.¹⁵⁴ The plan further required close operational fires to destroy the remaining Iraqi artillery units in range of the breach site.

Though a large quantity of Iraqi artillery had been destroyed earlier, the mission required further operational fires to target the estimated one hundred remaining systems in the vicinity of the breach. To reinforce the main effort, the VII Corps Artillery directed three FABs, two DIVARTYs, and 50% of the theater air effort to mass on an area forty kilometers by 20 kilometers long similar to a ‘strike sector’ in Soviet doctrine.¹⁵⁵ Over a thirty-minute period, the VII Corps Artillery delivered 6,136 cannon rounds, 414 rockets, and coordinated 565,500 lbs. of bombs in the close fight. The assets combined for the destruction of fifty tanks, 139 armored personnel carriers, and 152 field artillery pieces.¹⁵⁶ The most devastating effect was from MLRS which delivered the new M26 Dual Purpose Improved Conventional Munition or DPICM rocket. DPICM saturated large areas with different types of bomblets which shredded the Iraqi artillery and armor, accurately labeled as the “grid square removal system.”¹⁵⁷

The 1st Infantry Division artillery lacked the massed heavy firepower organic to the VII Corps Artillery to generate a window of opportunity for further exploitation with ground maneuver. Due to the latter’s relentless artillery and the air barrage, the breach took only two hours instead of the anticipated fourteen. Likewise, the Iraqi artillery did not fire on the Soldiers of the 1st Infantry Division. According to BG Abrams, “This is likely the first time in military history that an artillery preparation for a deliberate breaching operation has been so

¹⁵⁴ Bourque, *Jayhawk!*, 191-192; US Department of the Army, *Field Manual (FM) 3-90-1, Offense and Defense, Volume 1* (Washington, DC: Government Printing Office, 2013), Glossary-5. A breach is as an operation to break through or establish a passage through an enemy obstacle.

¹⁵⁵ VII Corps Artillery Persian Gulf War AAR, 39. A strike sector is a location where Soviet artillery massed to generate operational effects.

¹⁵⁶ Dastrup, *Artillery Strong*, 8.

¹⁵⁷ Scales, *Certain Victory*, 203.

comprehensive that not one Soldier lost his life during the operation.”¹⁵⁸ BG Robert H. Scales, Director of the Desert Storm Study Project, credited BG Abrams and VII Corps Artillery Staff for leveraging missiles, fighter-bomber aircraft, and attack helicopters to destroy the Iraqi VII Corps.¹⁵⁹

Once complete with the destruction of the Iraqi VII Corps, the Jayhawks focused their efforts on the destruction of the RGFC. VII Corps Artillery likewise began moving north into southern Kuwait, finally engaging the RGFC on February 26th. LTG Franks told the corps, “we are going to drive the corps hard for the next twenty four to thirty six hours, day and night, to overcome the resistance and to prevent the enemy from withdrawing.”¹⁶⁰ Up to this point, the VII Corps Artillery lost zero personnel to Iraqi counterfire. Through no Iraqi artillery fired on the breach days earlier, February 27-28 was different. The VII Corps Artillery conducted continuous counterfire missions with acquisitions from the CTAD radars during the 48-hour period against the RGFC, resulting in their retrograde at 66% strength.¹⁶¹ Radars enabled the VII Corps Artillery to “pick up the incoming trajectory, compute the point of origin, and pass the targeted grid location to the fire direction center. Accurate, devastating fires, usually from the MLRS, would arrive at the Iraqi positions within a very few minutes.”¹⁶² The surgical application of MLRS and incessant joint fires took its toll on the RGFC as it withdrew back into Iraq.¹⁶³

The VII Corps Artillery completed its participation in the Persian Gulf War on February 28, 1991. Though not entirely executed according to plan, the AAR reveals primarily positive lessons from the operation. Specifically, it was ATACMS, GPS, MLRS raids, radars, and

¹⁵⁸ Dastrup, *Artillery Strong*, 8.

¹⁵⁹ Scales, *Certain Victory*, 226.

¹⁶⁰ Bourque, *Jayhawk!*, 304.

¹⁶¹ Scales, *Certain Victory*, 209.

¹⁶² Abrams, “The Gulf War and European Artillery,” 8.

¹⁶³ Bourque, *Jayhawk!*, 460.

Apaches synchronized with airpower that ensured a quantifiable advantage over the Iraqis.¹⁶⁴ Correspondingly, centralized application of the new technology and integrated procedures with the Air Force enabled the VII Corps Artillery to “prep the battlefield” and subsequently mass at the breach with joint fires, as envisioned in AirLand Battle doctrine. The conflict after-action review likewise explains, “cooperation between the ALO (Air Liaison Officer) and FSE (Fire Support Element) was excellent. Together, these elements redirected CAS (Close Air Support), passed high payoff targets, and deconflicted Air Force and surface to surface fires.”¹⁶⁵ With regard to multi-domain operational fires, BG Abrams said that “outranged by the enemy, they [VII Corps Artillery] got help from the Air Force to help level the playing field, then used raids and UAVs to finish the initial job. When the Iraqi artillery finally spoke, they were quickly silenced by the radars and MLRS.”¹⁶⁶ This was the concluding action for the VII Corps Artillery.

The VII Corps Artillery deactivated in Germany on March 15, 1992, with zero casualties from the war.¹⁶⁷ Transferred to the V Corps Artillery, a few of the non-divisional artillery battalions remained in Germany. This task-organization change, and redeployment of forces broke the “free-world’s largest corps artillery,” reducing the total in the US Army to four.¹⁶⁸ The remaining corps artillery served for the next ten years before inactivation during the early years of the wars in Iraq and Afghanistan. Though the colors of the VII Corps Artillery cased for the last time, their actions in WWII and the Persian Gulf War are forever remembered in the annals of history.

¹⁶⁴ VII Corps Artillery Persian Gulf War AAR, 7.

¹⁶⁵ *Ibid.*, 7-8.

¹⁶⁶ Abrams, “The Gulf War and European Artillery,” 9.

¹⁶⁷ Janice McKenney, *Army Lineage Series, Field Artillery Part 1*, 16.

¹⁶⁸ Fred Marty, “State-of-the-Branch Address 1991,” *The Fires Journal* (December 1991): 2, 11.

Conclusion

The impact of VII Corps Artillery during both WWII and the Persian Gulf War is undisputed. The corps artillery in unison with airpower or naval surface fire support in Normandy, and airpower again in Desert Storm, gave the VII Corps commander the ability to synchronize multi-domain operational fires. Notably, though, both campaigns necessitated pre-established air superiority to accomplish the task. In contrast, air superiority is not guaranteed in the complex operational environment portrayed beyond 2028 in the MDO concept.¹⁶⁹ This fact requires the joint force to reintegrate with Army ground-based operational fires – which is problematic, as its operational fires capability is currently non-existent. As reinforced by maneuver commanders:

No branch of the Army has suffered a greater identity crisis than Field Artillery, as a result of transformation, COIN-centric [counterinsurgency] operations and the non-standard manpower demands of OIF/OEF [Operation Iraqi Freedom/Operation Enduring Freedom]. The once mighty “King of Battle” has been described by one of its own officers as a dead branch walking.¹⁷⁰

The reduction of field artillery force structure at the corps due to the wars in Iraq and Afghanistan decimated the branch and its long-standing reputation as the King of Battle. In stark contrast, chapters one and three illuminate the decisive role of the VII Corps Artillery played in generating multi-domain effects in LSCO. Both campaigns required a permanent corps artillery headquarters streamlined to achieve synergy amongst the domains at the operational level. Most effectively employed in a centralized manner to mass at a decisive point and/or in support of the main effort, the VII Corps Artillery in conjunction with joint assets enabled the corps commander to achieve his campaign objectives. These functions rest outside the span of control of a DIVARTY and/or FAB past and present. Therefore, historical analysis of corps artillery

¹⁶⁹ US Army, *TRADOC Pamphlet 525-31-1* (2018), vii.

¹⁷⁰ Sean MacFarland, Michael Shields, and Jeffery Snow, *The King and I: The Impending Crisis in the Field Artillery's Ability to Provide Fire Support to Maneuver Commanders*, accessed January 8, 2019, www.npr.org/documents/2008/may/artillerywhitepaper.pdf.

employment and understanding of future adversarial capabilities proves that the Army and joint force cannot continue its overreliance on airpower to deliver operational effects.

Codifying the definition of operational fires in joint and service doctrine is a necessary initial step for revitalizing the corps artillery. In particular, it must contain relevant metrics that can measure operational fires on the battlefield vice strategic or tactical fires. In contrast, the current doctrinal ambiguity reduces the Army's and joint force's ability to operate with a common lexicon, and thus generates duplicate effects. In addition, synchronizing and employing operational fires at the corps requires the establishment of three standing OFC (one per corps). The OFCs should include at a minimum an HHB, FAB (existing force structure already in place), Air Defense Artillery Brigade, and dedicated logistical support. The potential near-peer threat likewise necessitates that the headquarters consolidates the functions of joint intelligence, cyberspace, electronic warfare, space, long-range precision fires, and air defense for the corps. Moreover, the commander (brigadier general) requires the necessary authority and joint liaisons to synchronize fires within all domains and thus colloquially "have a seat at the table" with the joint force. In addition, fires capability must likewise be reestablished in the DIVARTY. Extended range delivery assets (rocket or cannon) are required to protect the three corps aligned FABs from continued dismantling to support division operations.

Finally, the activation of Army Futures Command to see beyond the tyranny of the present is a positive step. Nonetheless, the Army must rapidly determine the right material solutions to add over time.¹⁷¹ Therefore, prioritization of Long Range Precision Fires capability to replace the ATACMS is essential. Like the requirement for deep fires during the Persian Gulf War, the future battlefield beyond 2028 requires the ranges of artillery to extend beyond 500km. Increased range will enable standoff and subsequent penetration of A2/AD capabilities of peer

¹⁷¹ Joe Lacdan, "Establishment of Army Futures Command Marks a Culture Shift" *Army News Service*, August 27, 2018, accessed October 17, 2018, <https://army.mil/article/210371>.

threats thus allowing air and ground freedom of maneuver. In combination, the increased capability of rocket and missile technology synchronized by the OFC will increase the lethality of joint and Army multi-domain operational fires.

In conclusion, the OFC is not meant to replicate existing capability resident elsewhere in the Army or joint force. The new force structure satisfies an identified need in a world where the operating environment and peer adversaries have become more capable and complex.

Overreliance on airpower to achieve operational effects is empowering peer adversaries to create new means to disrupt its employment. Therefore, it is now time for the US Army to empower the “King of Battle” at the corps as experienced in history with VII Corps Artillery.

Bibliography

Doctrine

US Department of the Defense, Joint Staff. *Joint Publication (JP) 1-02, Department of Defense Dictionary of Military and Associated Terms*. Washington, DC: Government Printing Office, 2016.

_____. *Joint Publication (JP) 3-0, Joint Operations*. Washington, DC: Government Printing Office, 2018.

_____. *Joint Publication (JP) 3-01, Countering Air and Missile Threats*. Washington, DC: Government Printing Office, 2017.

_____. *Joint Publication (JP) 3-09, Joint Fire Support*. Washington, DC: Government Printing Office, 2014.

US Department of the Army. *Field Manual (FM) 3-0, Operations*. Washington, DC: Government Printing Office, 2017.

_____. *Field Manual (FM) 3-09, Field Artillery Operations and Fire Support*. Washington, DC: Government Printing Office, 2014.

_____. *Field Manual (FM) 3-90-1, Offense and Defense, Volume 1* (Washington, DC: Government Printing Office, 2013).

_____. *Field Manual (FM) 3-94, Theater Army, Corps, and Division Operations*. Washington, DC: Government Printing Office, 2018.

_____. *Field Manual (FM) 6-20, Fire Support in the AirLand Battle*. Washington, DC: Government Printing Office, 1988.

_____. *Field Manual (FM) 100-5, Operations*. Washington, DC: Government Printing Office, 1982.

_____. *Army Technical Publication (ATP) 3-94.2, Deep Operations*. Washington, DC: Government Printing Office, 2016.

_____. *Army Techniques, Tactics, and Procedures (ATTP) 6-22-2, Corps Artillery, Division Artillery, and Field Artillery Brigade Headquarters*. Washington, DC: Government Printing Office, 1993.

_____. *TRADOC Pamphlet 525-31-1, The U.S. Army in Multi-Domain Operations 2028*. Washington, DC: Government Printing Office, 2018.

_____. *Training Circular (TC) 7-100.2, Opposing Force Tactics*. Washington, DC: Government Printing Office, 2011.

US Department of the Navy. *Field Training Publication (FTP) 167, Landing Operations Doctrine*. Washington, DC: Government Printing Office, 1938.

War Department. Chief of Staff. *Field Manual (FM) 6-20, Tactical Employment of Field Artillery*. Washington, DC: Government Printing Office, 1941.

_____. *Field Manual (FM) 6-20, Tactical Employment of Field Artillery*. Washington, DC: Government Printing Office, 1944.

_____. *Field Manual (FM) 6-100, Tactics and Technique of Division Artillery and Higher Artillery Echelons*. Washington, DC: Government Printing Office, 1944.

Primary Sources

G-3 Section, Headquarters VII Corps. *Operation Neptune Troop List*. United States Army Command and General Staff College. Battle Analysis: D-Day, Course P651, Vol. 1, Part 1. Ike Skelton Combined Arms Research Library, Fort Leavenworth, KS.

_____. *Capture of Cherbourg and Cotentin Peninsula AAR, 23 July 1944*. United States Army Command and General Staff College. Battle Analysis: D-Day, Course P651, Vol. 1, Part 3. Ike Skelton Combined Arms Research Library, Fort Leavenworth, KS.

_____. *VII Corps Utah Area Simplified Buildup Priority List*. United States Army Command and General Staff College. Battle Analysis: D-Day, Course P651, Vol. 1, Part 1. Ike Skelton Combined Arms Research Library, Fort Leavenworth, KS.

_____. *Capture of Cherbourg and Cotentin Peninsula After-Action Review, 6 June – 1 July 1944*. United States Army Command and General Staff College. Battle Analysis: D-Day, Course P651, Vol. 1, Part 3. Ike Skelton Combined Arms Research Library, Fort Leavenworth, KS.

_____. *The History of the VII Corps U.S. Army, Covering Operations in Normandy, France, From 1-31 July 1944, Chapter 3, Operation Cobra*. United States Army Command and General Staff College. Battle Analysis: D-Day, Course P651, Vol. 1, Part 3. Ike Skelton Combined Arms Research Library, Fort Leavenworth, KS.

Harris, Harry. "Role of Land Forces In Ensuring Access To Shared Domains." Lecture, LANPAC Symposium, Honolulu, HI, May 25, 2016.

Headquarters VII Corps Artillery, VII Corps. *European Theater of Operations After Action Review, 30 July 1944*. File VII Corps Artillery After-Action Review June 6, 1944 – May 9, 1945. Folder N122982. Ike Skelton Combined Arms Research Library, Fort Leavenworth, KS.

_____. *European Theater of Operations After Action Review, 3 August 1944*. File VII Corps Artillery After-Action Review June 6, 1944 – May 9, 1945. Folder N122982. Ike Skelton Combined Arms Research Library, Fort Leavenworth, KS.

_____. *European Theater of Operations After Action Review, 8 June 1945*. File VII Corps Artillery After-Action Review June 6, 1944 – May 9, 1945. Folder N122982. Ike Skelton Combined Arms Research Library, Fort Leavenworth, KS.

- _____. *Annex D, Corps OPLAN 1990-2, Operation Desert Saber*. File 917795. Volume 17C, VII Corps Artillery. Gulf War Collection. Ike Skelton Combined Arms Research Library, Fort Leavenworth, KS.
- _____. *Desert Storm Standard Operating Procedures, Part 1*. File 947460. Volume 17C, VII Corps Artillery. Gulf War Collection. Ike Skelton Combined Arms Research Library, Fort Leavenworth, KS.
- _____. *Operation Desert Storm: A Fire Support Perspective*. Presentation. File 918752. Volume 17C, VII Corps Artillery. Gulf War Collection. Ike Skelton Combined Arms Research Library, Fort Leavenworth, KS.
- Headquarters 42nd Field Artillery Brigade, VII Corps Artillery. *42nd FA BDE Desert Storm After-Action Review*. File 918752. Volume 17C, VII Corps Artillery. Gulf War Collection. Ike Skelton Combined Arms Research Library, Fort Leavenworth, KS.
- Kearney, Thomas A, and Eliot A. Cohen. Gulf War Air Power Survey Summary Report. Washington, DC: Government Printing Office, 1993.
- US Army, Eighth Army, Artillery Officer. *A Study of the Employment and Effectiveness of the Artillery With the Eighth Army During the Period October 1951-July 1953*. Seoul, Korea, 1954.
- US Army Field Artillery School. “DIVARTY: A Force Multiplier for the BCT and Division.” April 30, 2014. Accessed September 18, 2018. *Fires Center of Excellence Webpage*, <http://sill-www.army.mslil/USAFAS/DIVARTY.html>.
- US Army Forces Command. “US Army Forces Command Division Artillery (DIVARTY) Implementation Order.” Fort Bragg, NC, 2014.
- US Department of the Army. *The Army Vision*. Washington, DC: Government Printing Office, 2018.
- War Department, Chief of Staff. United States Forces European Theater. “Report on Study of Field Artillery Operations.” 1945.
- _____. United States Forces European Theater. “Study of the Organization and Equipment of Field Artillery Units.” 1945.

Secondary Sources

- Abrams, Creighton Jr. “The Gulf War and European Artillery.” Association of the United States Army Webpage. January 20, 2015. Accessed December 11, 2018. <https://armyhistory.org/the-gulf-war-and-european-artillery>.
- Active and National Guard Field Artillery Units. *The Fires Center of Excellence Online Redbook*. Accessed February 24, 2019. <http://sill-www.army.mil/firesbulletin/archives/2019/jan-feb/articles/article-5.pdf>.

- Aquino, Alex. "Force Structure Matters: The US Field Artillery in Operational Art." Monograph, School of Advanced Military Studies, US Army Command and General Staff College, 2015-01.
- Ambrose, Stephen. *D-Day, June 6, 1944: The Climactic Battle of World War II*. New York: Simon & Schuster, 1994.
- Balkoski, Joseph. *Utah Beach, The Amphibious Landing and Airborne Operations on D-Day*. Mechanicsburg, PA: Stackpole Books, 2005.
- Blumenson, Martin. *Breakout and Pursuit*. Washington, DC: Center of Military History, 1993.
- Bourque, Stephen. *Jayhawk! The VII Corps in the Persian Gulf War*. Washington, DC: Center of Military History, 2002.
- _____. *Beyond the Beach, The Allied War Against France*. Annapolis, MD: Naval Institute Press, 2018.
- Bradley, Omar. *A Soldier's Story*. New York: Holt Publishing, 1951.
- Brown, Frederic. "Spearhead, The Story of the 3rd Armored Division Artillery." *The Fires Journal* (September 1946): 507.
- Calhoun, Mark. "Close Air Support and Bombardment Theory: Operation Cobra." In *Lethal and Non-lethal Fires, Historical Case Studies of Converging Cross-Domain Fires in Large-Scale Combat Operations*, 163-182. Fort Leavenworth, KS: Army University Press, 2018.
- Carafino, James. *After D-Day, Operation Cobra and the Normandy Breakout*. Boulder, CO: Lynne Rienner Publishers, 2000.
- Center of Military History Staff. *Normandy, The U.S. Army Campaigns of World War II*. Washington, DC: Center of Military History, 1972.
- Compton, Chris and Lewis Boothe. "The Fires Complex, Organizing to Win in Large Scale Combat Operations." *The Fires Journal* (May-June 2018): 4-5.
- Collins, Lawton. "Tribute to Artillery." *The Fires Journal* (September 1946): 525.
- Cosgrove, William. *Time on Target: The 945th Field Artillery Battalion in World War II*. William Cosgrove III, 1997.
- Dastrup, Boyd. *Cedat Fortuna Peritis. A History of the Field Artillery School*. Fort Leavenworth, KS: Combat Studies Institute Press, 2012.
- _____. *Artillery Strong: Modernizing the Field Artillery for the 21st Century*. Fort Leavenworth, KS: Combat Studies Institute Press, 2018.
- _____. *King of Battle, A Branch History of the U.S. Army's Field Artillery*. Fort Monroe, VA: US Army Training and Doctrine Command, 1992.

- Gatchel, Theodore. *At the Water's Edge, Defending against the Modern Amphibious Assault*. Annapolis, MD: Naval Institute Press, 1996.
- Gordon, Keith "Field Artillery: Lending a Touch of Class at the Operational Level." Monograph, School of Advanced Military Studies, US Army Command and General Staff College, 1989.
- Harrison, Gordon. *United States Army in World War II: The European Theater of Operations, Cross-Channel Attack*. Washington, DC: Center of Military History, 1993.
- Hogg, Ian. *Artillery in Color, 1920-1963*. New York: Arco Publishing, 1980.
- Hughes, Daniel. *Moltke On the Art of War, Selected Writings*. New York: Random House, 1993.
- Isserson, Georgii. *The Evolution of Operational Art*. Fort Leavenworth, KS: Combat Studies Institute Press, 2013.
- Jomini, Antione Henry. "The Art of War," In *Roots of Strategy Book #2*, 389-557. Harrisburg, PA: Stackpole Books, 1987.
- King, Benjamin. *Victory Starts Here: A 35-year History of the US Army Training and Doctrine Command*. Fort Leavenworth, KS: Combat Studies Institute Press, 2009.
- Kraus, Theresa, and Frank Schubert. *The Whirlwind War: The United States Army in Operations Desert Shield and Desert Storm*. Washington, DC: Government Printing Office, 1995.
- Lacdan, Joe. "Establishment of Army Futures Command Marks a Culture Shift." *Army News Service*. August 27, 2018. Accessed October 17, 2018. <https://army.mil/article/210371>.
- Lundy, Michael. "Meeting the Challenge of Large-Scale Combat Operations Today and Tomorrow." *Military Review* (October 2018). Accessed October 10, 2018. <https://www.armyupress.army.mil/Journals/Military-Review/English-Edition/Archives/September-October-2018/Lundy-Foreword>.
- MacFarland, Sean, Michael Snow, and Jeffery Snow. *The King and I: The Impending Crisis in the Field Artillery's Ability to Provide Fire Support to Maneuver Commanders*. Accessed January 8, 2019. www.npr.org/documents/2008/may/artillerywhitepaper.pdf.
- Marty, Fred. "State-of-the-Branch Address 1991." *The Fires Journal* (December 1991): 2, 11.
- McKenney, Janice. *The Organizational History of the Field Artillery, 1775-2003*. Washington, DC: Center of Military History, 2010.
- _____. *Army Lineage Series, Field Artillery Part I*. Washington, DC: Center of Military History, 2010.
- Morison, Samuel. *History of United States Naval Operations in World War II, Volume XI*. Boston, MA: Atlantic Monthly Press, 1984.

- Novotny, Robert. "Defining Operational Fires." Monograph, Naval War College, 2006.
- Rice, William. "Operational Fires – What's In A Name?" Monograph, School of Advanced Military Studies, US Army Command and General Staff College. 1990.
- Rogers, Bernard. *Cedar Falls- Junction City: A Turning Point*. Washington, DC: Center for Military History, 1989.
- Romjue, John. *From Active Defense to AirLand Battle: The Development of Army Doctrine, 1973-1982*. Washington, DC: US Government Printing Office, 1984.
- Scales, Robert. *Certain Victory: The United States Army in the Gulf War*. Fort Leavenworth, KS: US Army Command and General Staff College Press, 1994.
- Sommerville, D. S. "Corps and Non-Divisional Artillery." *The Fires Journal* (August 1944): 516-520.
- Swain, Richard. "*Lucky War*" *Third Army in Desert Storm*. Fort Leavenworth, KS: US Army Command and General Staff College Press, 1994.
- Symonds, Craig. *Operation Neptune, The D-Day Landings and the Allied Invasion of Europe*. New York: Oxford University Press, 2016.
- Tangredi, Sam. *Anti-Access Warfare, Countering A2/AD Strategies*. Annapolis, MD: Naval Institute Press, 2013.
- The Hall of Valor Project. "Williston B. Palmer." Accessed December 11, 2018. <https://valor.militarytimes.com/hero/100340>.
- Townsend, Stephen. "Accelerating Multi-Domain Operations: Evolution of an Idea." August 6, 2018. Accessed November 1, 2018. Army.mil Webpage. <https://www.army.mil/article/209492>.
- Vego, Milan. *Operational Warfare*. Newport, RI: US Naval War College Press, 2000.
- Ward, Lincoln. "The Division Artillery: Linking Strategy to Tactics." Monograph, School of Advanced Military Studies, US Army Command and General Staff College, 2017.
- Weigley, Russell. *Eisenhower's Lieutenants, The Campaign of France and Germany 1944-1945*. Bloomington, IN: Indiana University Press, 1981.
- Wilson, John. *Armies, Corps, Divisions, and Separate Brigades, Army Lineage Series*. Washington, DC: US Army Center of Military History, 1987.
- Young, Christopher. *Gators of Neptune, Naval Amphibious Planning for the Normandy Invasion*. Annapolis MD: Naval Institute Press, 2006.
- Zaloga, Steven. *Operation Cobra, Breakout from Normandy*. Oxford, UK: Osprey Publishing Limited, 2001.