

- ❖ The mechanism behind blast-induced traumatic brain injury is not well understood
- ❖ Human and animal tissue are difficult to use due to decay, demand, and mechanical property variation
- ❖ It is preferable to prepare samples a day or two before blast testing rather than immediately prior to testing

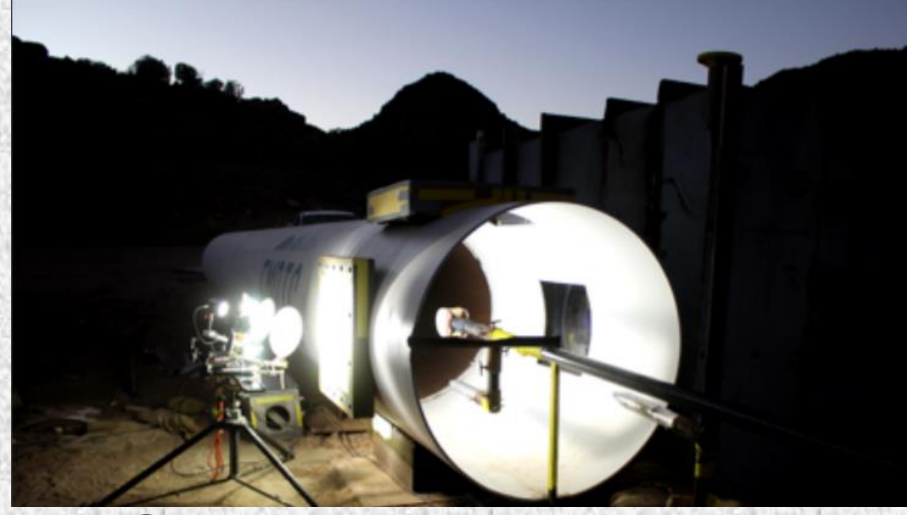

Figure 1. Setup of a blast test at an EMRTC facility

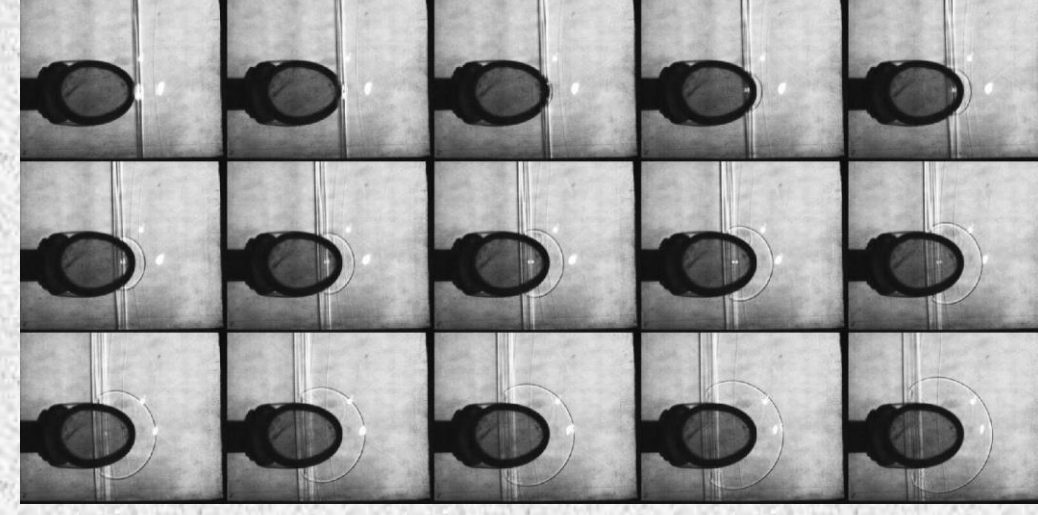

Figure 2. Progression of a shockwave through CSF simulating fluid (Hargather, 2017)

## Design Criteria

### Material Requirements:

- ❖ Transparent
- ❖ Reproducible
- ❖ Similar mechanical properties to white and gray brain matter
- ❖ Adhesion at the white-gray matter interface
- ❖ Correct geometric dimensions for anatomical features obtained from literature (Mata, 2010)

### Chosen Material: Polyacrylamide Gel (PAA)

## Materials and Methods

### Fabrication of Test Objects

#### Mold Design



Figure 3. 3D printed miniature brain mold

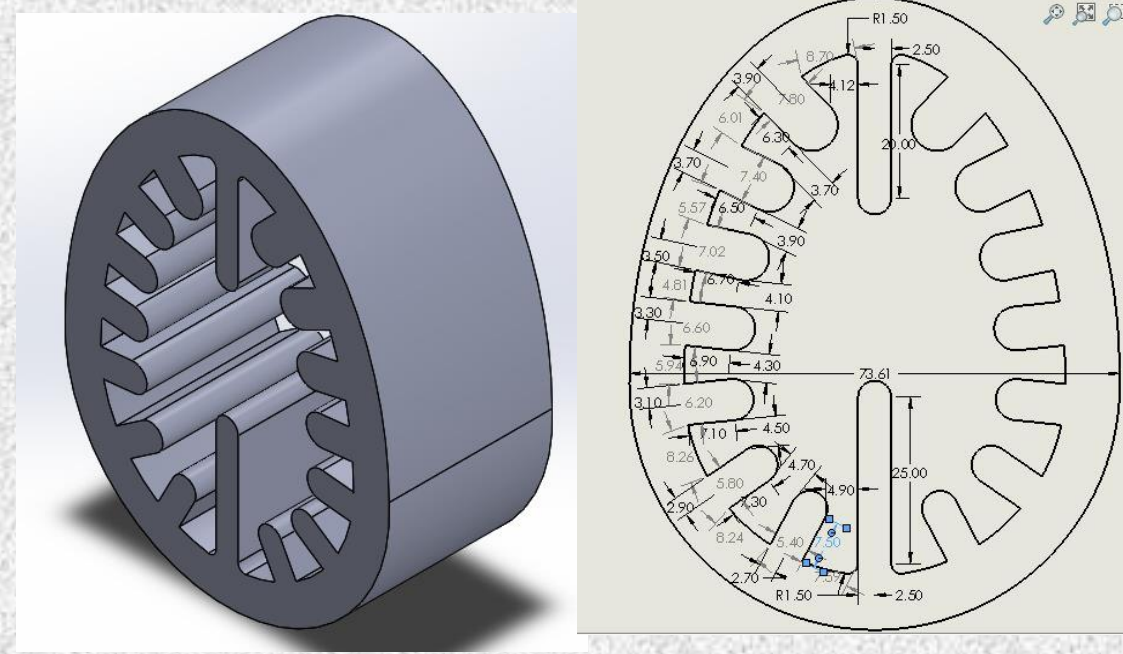

Figure 4. SolidWorks model of white matter insert

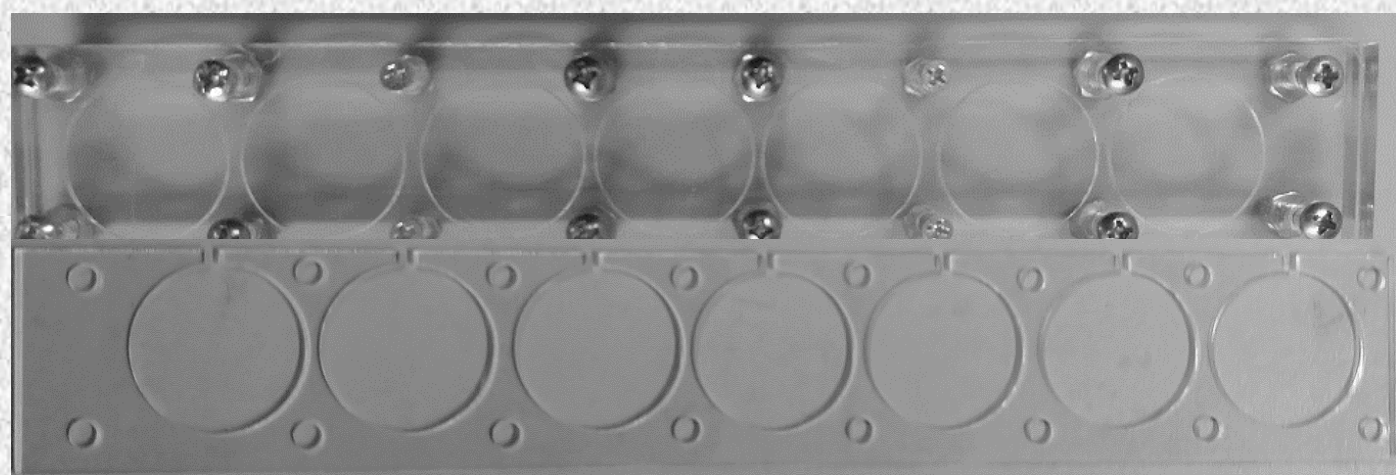

Figure 5. Pre-existing, three piece disk mold with 25 mm wells



Figure 6. Student synthesizing PAA (left) and filling disk molds with PAA solution (right)

### Hydrogel Characterization

#### Swell Testing



Figure 7. PAA disk samples swelled for 36 hours (left) and miniature brain mimics swelled for 3 days (right)

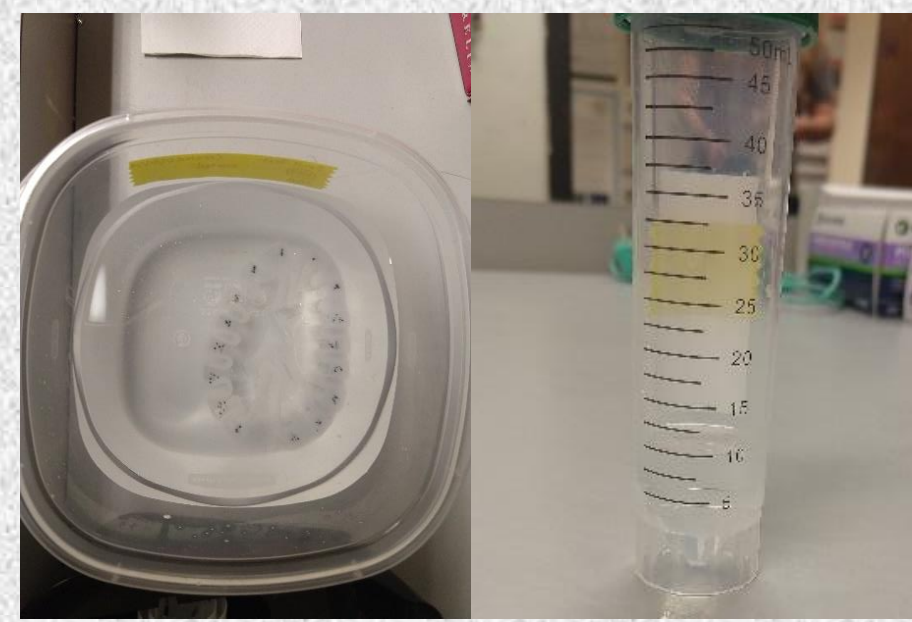

Figure 8. Samples were swelled in closed containers filled with Isoton II Diluent

Type	Disk						Brain		
	5		7		10		Gray	Gray and White	White
Matter Type									
Acrylamide Weight %	5		7		10		5	7	10
Crosslink Ratio	15:1	60:1	15:1	60:1	15:1	60:1	60:1		

Table 1. Parameters for PAA Samples

#### Density Testing

- ❖ Disks were weighed and then submerged in water to determine change in volume.

#### Rheology

- ❖ A Rheometric Scientific SR5 Test Unit was used in conjunction with TA Orchestrator software to obtain the storage ( $G'$ ), loss ( $G''$ ), and shear ( $G^*$ ) moduli.



Figure 9. Rheometer test setup

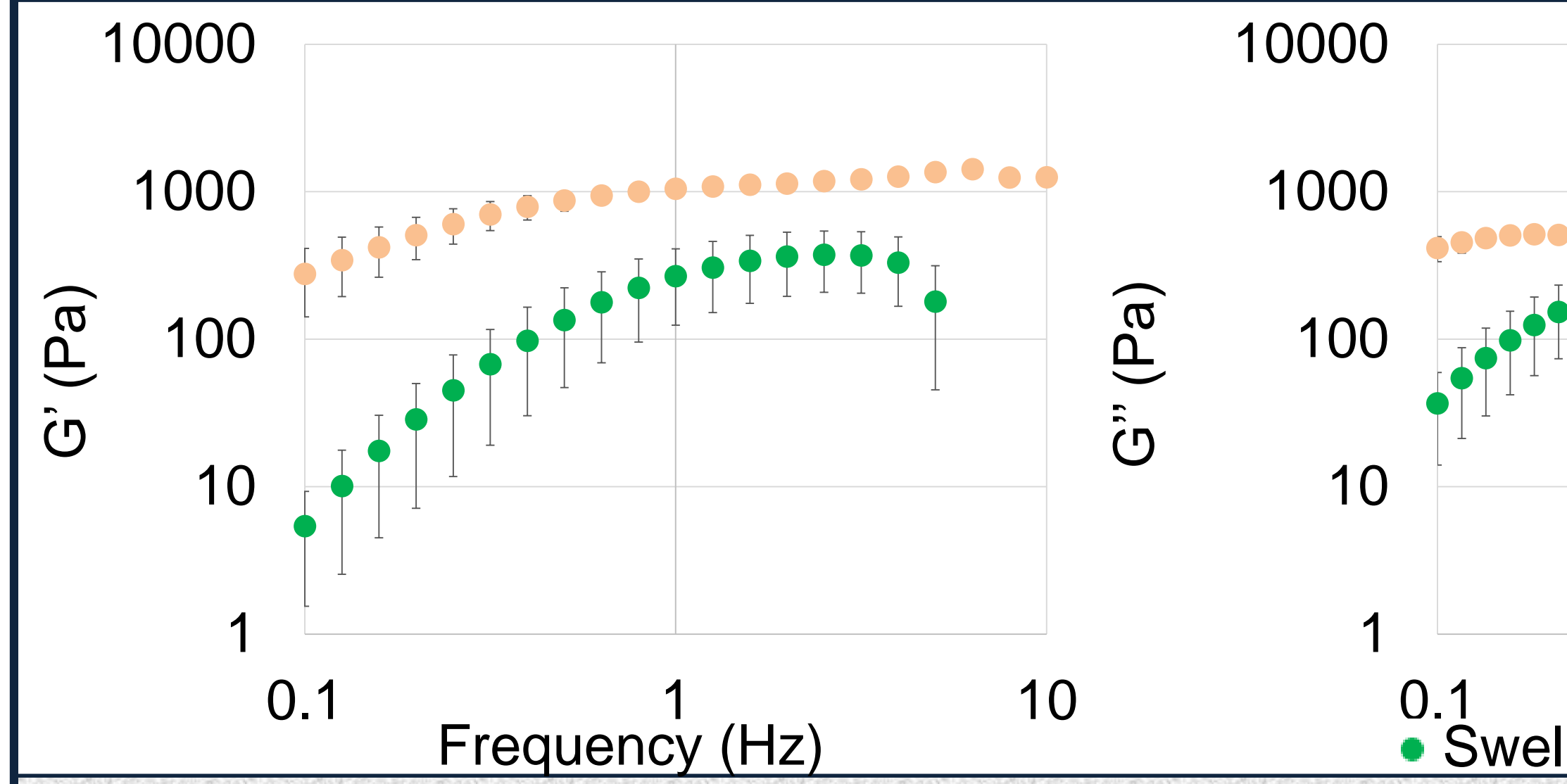

Figure 10. Comparison of  $G'$  and  $G''$  between swelled and unswollen PAA disks at a 60:1 crosslink ratio. The percent change in the storage modulus is 173.045% at 10Hz.

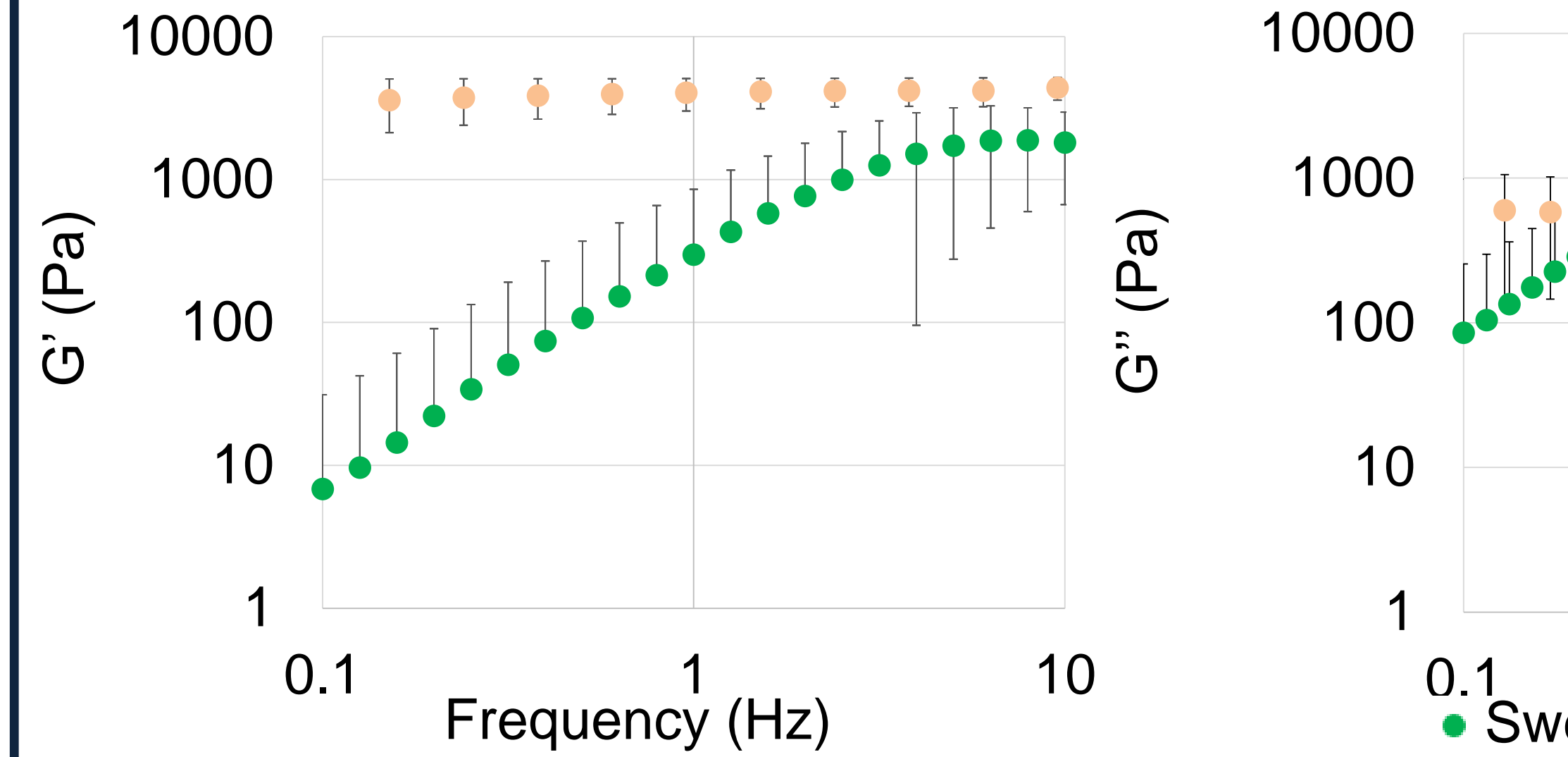

Figure 11. Comparison of  $G'$  and  $G''$  between swelled and unswollen PAA disks at a 60:1 crosslink ratio. The percent change in the storage modulus is 58.6045% at 10Hz.

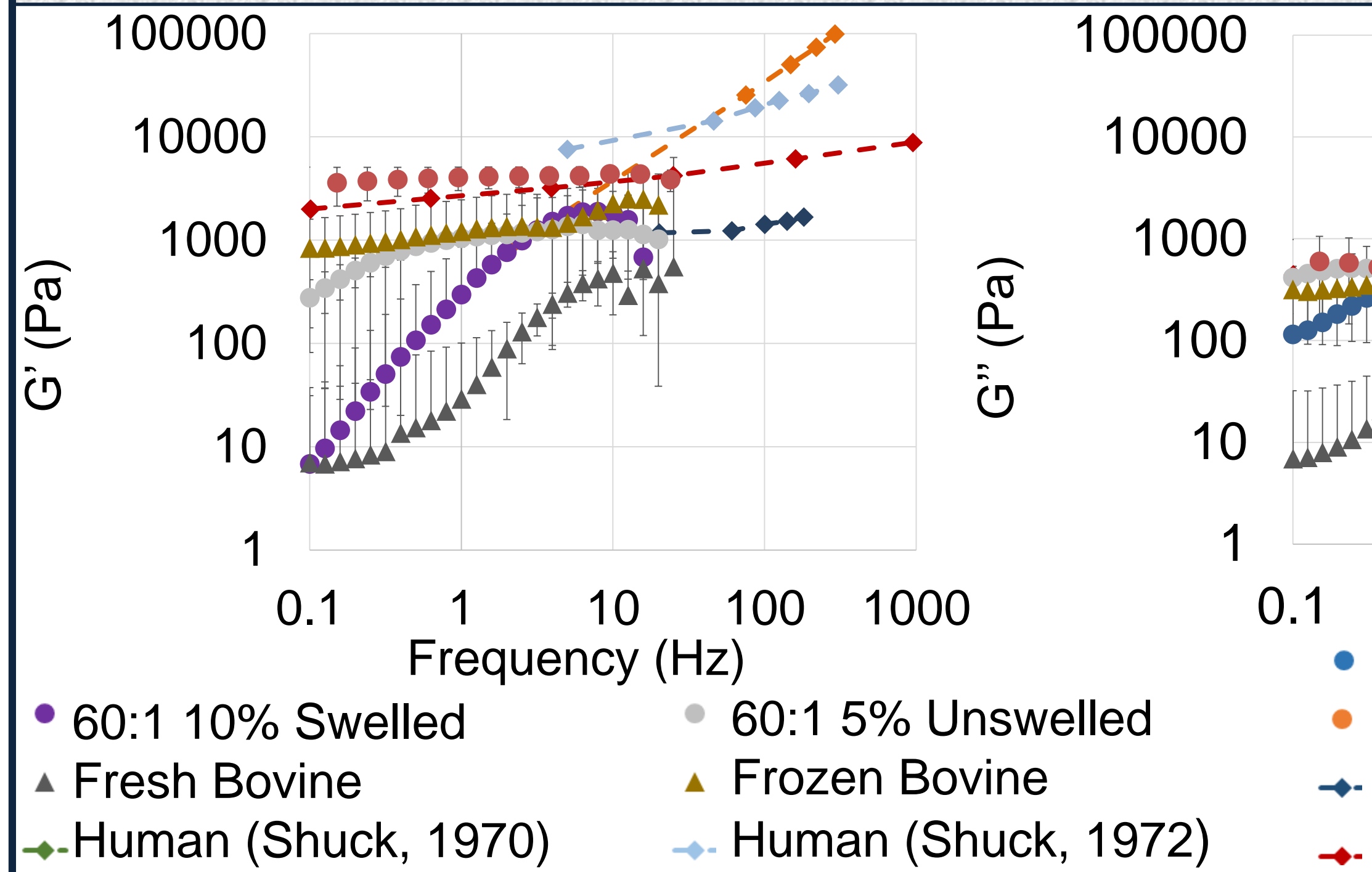

Figure 12. Comparison of  $G'$  and  $G''$  for fresh bovine brain, frozen bovine brain, and selected PAA disks (Chatelin, 2010).

## Discussion and Conclusion

- ❖ Swelled PAA disks are not a reliable representation of brain tissue
- ❖ Unswollen PAA maintains the desired mechanical properties
- ❖ Unconfined swell tests lead to asymmetrical swelling and deformation
- ❖ Swell testing under confined conditions may produce better results

### Limitations

- ❖ Cellular activity is not simulated
- ❖ PAA batches cannot be perfectly replicated

### Future Work

- ❖ A material will be optimized to better simulate  $G'$  and  $G''$
- ❖ Once the swelled brains are optimized, they will be subjected to blast testing

## Acknowledgements and References

The INTENSE REU is funded by the National Science Foundation (NSF) Grant #1710807, titled "Understanding Traumatic Brain Injury Mechanisms Using Fluid Structure Interaction." PI: Maj. Adam M. Willis, MD, Director PLUTSI.

1. Chatelin S, Biorheology. 2010, 47, 255-76.
2. Hargather M, 2017, Progression of a shockwave through CSF (image).
3. Hoge CW, The New England Journal of Medicine, 2008
4. Mata I, Brain Research, 2010, 1317, 297-304.