

REPORT DOCUMENTATION PAGE			Form Approved OMB NO. 0704-0188		
<p>The public reporting burden for this collection of information is estimated to average 1 hour per response, including the time for reviewing instructions, searching existing data sources, gathering and maintaining the data needed, and completing and reviewing the collection of information. Send comments regarding this burden estimate or any other aspect of this collection of information, including suggestions for reducing this burden, to Washington Headquarters Services, Directorate for Information Operations and Reports, 1215 Jefferson Davis Highway, Suite 1204, Arlington VA, 22202-4302. Respondents should be aware that notwithstanding any other provision of law, no person shall be subject to any penalty for failing to comply with a collection of information if it does not display a currently valid OMB control number. PLEASE DO NOT RETURN YOUR FORM TO THE ABOVE ADDRESS.</p>					
1. REPORT DATE (DD-MM-YYYY) 07-08-2019		2. REPORT TYPE Final Report		3. DATES COVERED (From - To) 11-Sep-2017 - 10-May-2019	
4. TITLE AND SUBTITLE Final Report: Acquisition of a PET/CT Imaging System for STEM Research and Education at Howard University			5a. CONTRACT NUMBER W911NF-17-1-0515		
			5b. GRANT NUMBER		
			5c. PROGRAM ELEMENT NUMBER 106012		
6. AUTHORS			5d. PROJECT NUMBER		
			5e. TASK NUMBER		
			5f. WORK UNIT NUMBER		
7. PERFORMING ORGANIZATION NAMES AND ADDRESSES Howard University 2400 6th Street NorthWest Washington, DC 20005 -9000			8. PERFORMING ORGANIZATION REPORT NUMBER		
9. SPONSORING/MONITORING AGENCY NAME(S) AND ADDRESS (ES) U.S. Army Research Office P.O. Box 12211 Research Triangle Park, NC 27709-2211			10. SPONSOR/MONITOR'S ACRONYM(S) ARO		
			11. SPONSOR/MONITOR'S REPORT NUMBER(S) 70502-LS-REP.1		
12. DISTRIBUTION AVAILABILITY STATEMENT Approved for public release; distribution is unlimited.					
13. SUPPLEMENTARY NOTES The views, opinions and/or findings contained in this report are those of the author(s) and should not be construed as an official Department of the Army position, policy or decision, unless so designated by other documentation.					
14. ABSTRACT					
15. SUBJECT TERMS					
16. SECURITY CLASSIFICATION OF:		17. LIMITATION OF ABSTRACT		15. NUMBER OF PAGES	19a. NAME OF RESPONSIBLE PERSON
a. REPORT UU	b. ABSTRACT UU	c. THIS PAGE UU	UU		Paul Wang
					19b. TELEPHONE NUMBER 202-865-3711

RPPR Final Report
as of 05-Sep-2019

Agency Code:

Proposal Number: 70502LSREP

Agreement Number: W911NF-17-1-0515

INVESTIGATOR(S):

Name: PhD Benjamin Tsui
Email: btsui1@jhmi.edu
Phone Number: 4432874025
Principal: N

Name: Mohsen Mosleh
Email: mmosleh@howard.edu
Phone Number: 2028066222
Principal: N

Name: Prabhakar Misra
Email: pmisra@howard.edu
Phone Number: 2028066245
Principal: N

Name: Paul Wang
Email: pwang@howard.edu
Phone Number: 2028653711
Principal: Y

Name: PhD Yunkou Wu
Email: yunkou.wu@howard.edu
Phone Number: 2028653742
Principal: N

Organization: **Howard University**

Address: 2400 6th Street NorthWest, Washington, DC 200059000

Country: USA

DUNS Number: 056282296

EIN: 530204707

Report Date: 10-Aug-2019

Date Received: 07-Aug-2019

Final Report for Period Beginning 11-Sep-2017 and Ending 10-May-2019

Title: Acquisition of a PET/CT Imaging System for STEM Research and Education at Howard University

Begin Performance Period: 11-Sep-2017

End Performance Period: 10-May-2019

Report Term: 0-Other

Submitted By: Paul Wang

Email: pwang@howard.edu

Phone: (202) 865-3711

Distribution Statement: 1-Approved for public release; distribution is unlimited.

STEM Degrees:

STEM Participants:

Major Goals: This project was to request the purchase of a Bruker Albira PET/CT (Positron Emission Tomography /Computed Tomography) imaging system and any additional support equipment and materials to establish a nuclear medicine research core facility to complement the existing small animal MRI and optical imaging facility at Howard University. This new imaging core facility would support faculty research and student training at Howard University as well as at other HBCU's. The Bruker Albira PET/CT machine integrates the high detection sensitivity of PET function with a high-resolution feature of micro-CT. It can produce structural images of high resolution and quantitatively image physiochemical and biomedical processes. This highly versatile imaging system is able to integrate into our current biomedical, mechanical, and physical research workflow for a wide-range of applications in nanotechnology, biomedicine, physical sciences, and engineering.

Accomplishments: A Bruker Albira Si PET/SPECT/CT instrument was installed in a designated Molecular Imaging Lab in the Howard University Interdisciplinary Research Building in April 2019 (see attached installed machine and Acceptance and Survey Protocol). In addition to the PET/SPECT/CT scan room, the university has

RPPR Final Report as of 05-Sep-2019

also allocated a preparation lab adjacent to the PET/SPECT/CT scan room with a compressor to provide compressed air for the scanner. Prior to delivery of the original DoD funded PET/CT machine, additional funds were acquired from the NIH to add the SPECT (Single Photon Emission Computed Tomography) module, to upgrade the system to a more versatile PET/SPECT/CT instrument. Support equipment to complete the hot cell in the Molecular Imaging Lab was ordered and delivered. This includes a radio-HPLC detection system (Eckert & Ziegler Radiopharma FC-2000P), dose calibrator (Capintec CRC-55tR), well counter (AtomLab 500), survey meter (Ludum 14c), animal monitoring system (Biopac PW160), as well as safety and shielding materials (lead bricks, tabletop shields, syringe carriers, syringe shields, decontamination kits, shielded waste container, etc.) The instrument has received a license from the DC Department of Health Radiation Control Division for the PET/SPECT/CT machine as a radiation producing device (CT component, certificate attached). The Howard University Radiation Safety Office has submitted an application to Nuclear Regulatory Commission (NRC) to amend the University's NRC Materials License to include additional isotopes that will be used in PET/SPECT research. A graduate student from Department of Anatomy has signed up to use the CT module to conduct her PhD thesis research.

Training Opportunities: An initial training session provided by the manufacturer of the PET/SPECT/CT instrument has been scheduled for this fall and will be open to all the investigators in the research community who have expressed interests in performing PET/SPECT/CT research. The training will cover instrument hardware and software, workflows, CT/PET/SPECT quality control and image acquisition/reconstruction and advanced imaging techniques. Key members, including principle investigators of the research projects and the Imaging Core manager and staff, will receive more in-depth training with the goal of being able to train students and future users of the instrument. All users either already have or will undergo the annual radiation safety training and certification provided by the Howard University Radiation Safety Committee. The PET/SPECT/CT machine will be used in the teaching of a newly developed graduate Medical Physics program in the Department of Physics in the fall semester of 2019. The PET/SPECT/CT instrument will also be integrated in ongoing engagements with high school STEM programs, including lab tours, lectures and internships. Increasing the breadth of technology and applications of technology will enrich the engagements and will nourish interest in pursuing a STEM field in college.

Results Dissemination: Nothing to Report

Honors and Awards: Nothing to Report

Protocol Activity Status:

Technology Transfer: Nothing to Report

PARTICIPANTS:

Participant Type: PD/PI

Participant: Paul C Wang

Person Months Worked: 3.00

Project Contribution:

International Collaboration:

International Travel:

National Academy Member: N

Other Collaborators:

Funding Support:

Participant Type: Co-Investigator

Participant: Mohsen Mosleh

Person Months Worked: 2.00

Project Contribution:

International Collaboration:

International Travel:

National Academy Member: N

Other Collaborators:

Funding Support:

RPPR Final Report
as of 05-Sep-2019

Participant Type: Co-Investigator

Participant: Prabhakar Misra

Person Months Worked: 2.00

Project Contribution:

International Collaboration:

International Travel:

National Academy Member: N

Other Collaborators:

Funding Support:

Participant Type: Co-Investigator

Participant: Oladapo Bakare

Person Months Worked: 2.00

Project Contribution:

International Collaboration:

International Travel:

National Academy Member: N

Other Collaborators:

Funding Support:

Participant Type: Co-Investigator

Participant: Yunkou Wu

Person Months Worked: 4.00

Project Contribution:

International Collaboration:

International Travel:

National Academy Member: N

Other Collaborators:

Funding Support:

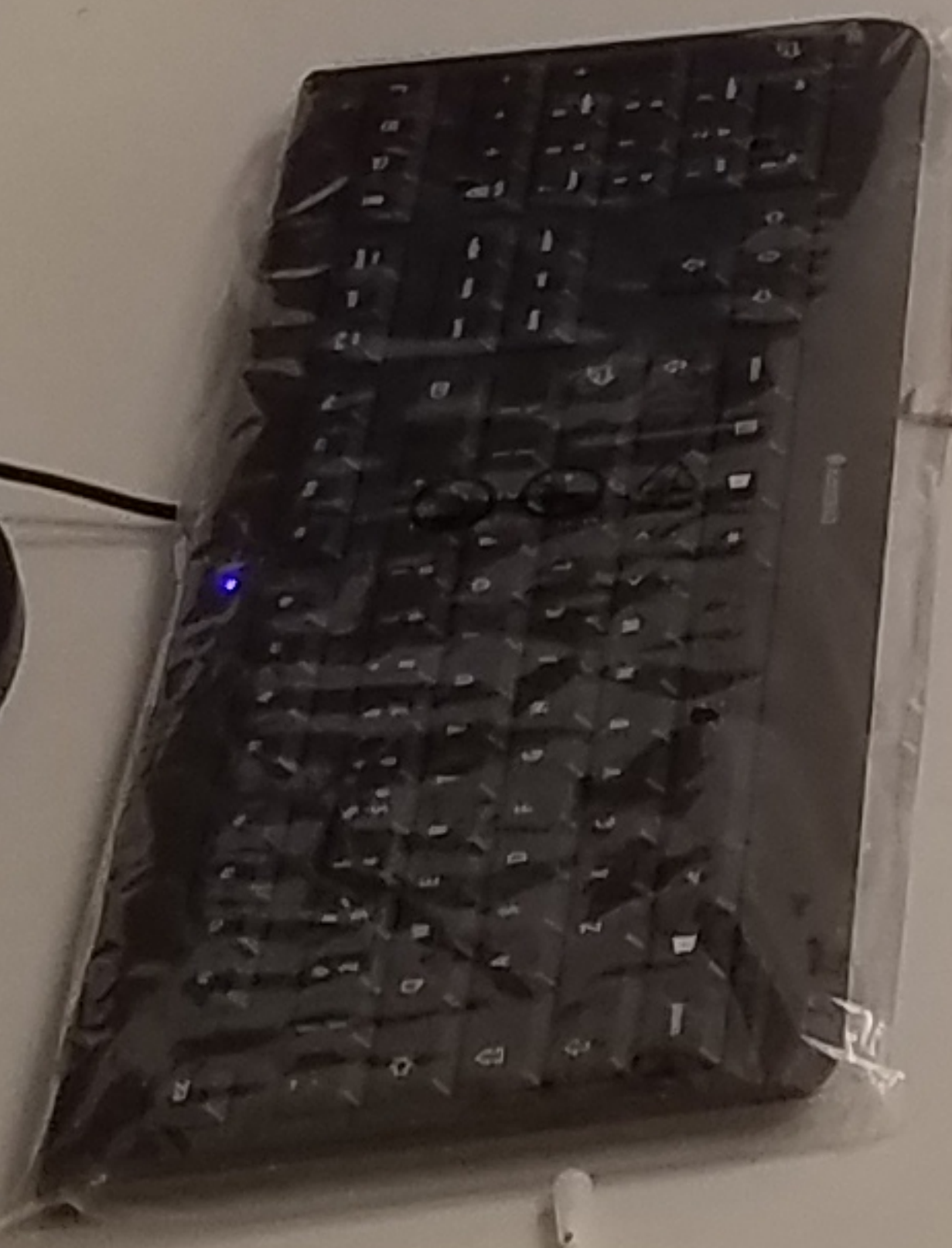

CAUTION
Unauthorized use prohibited

BRUKER

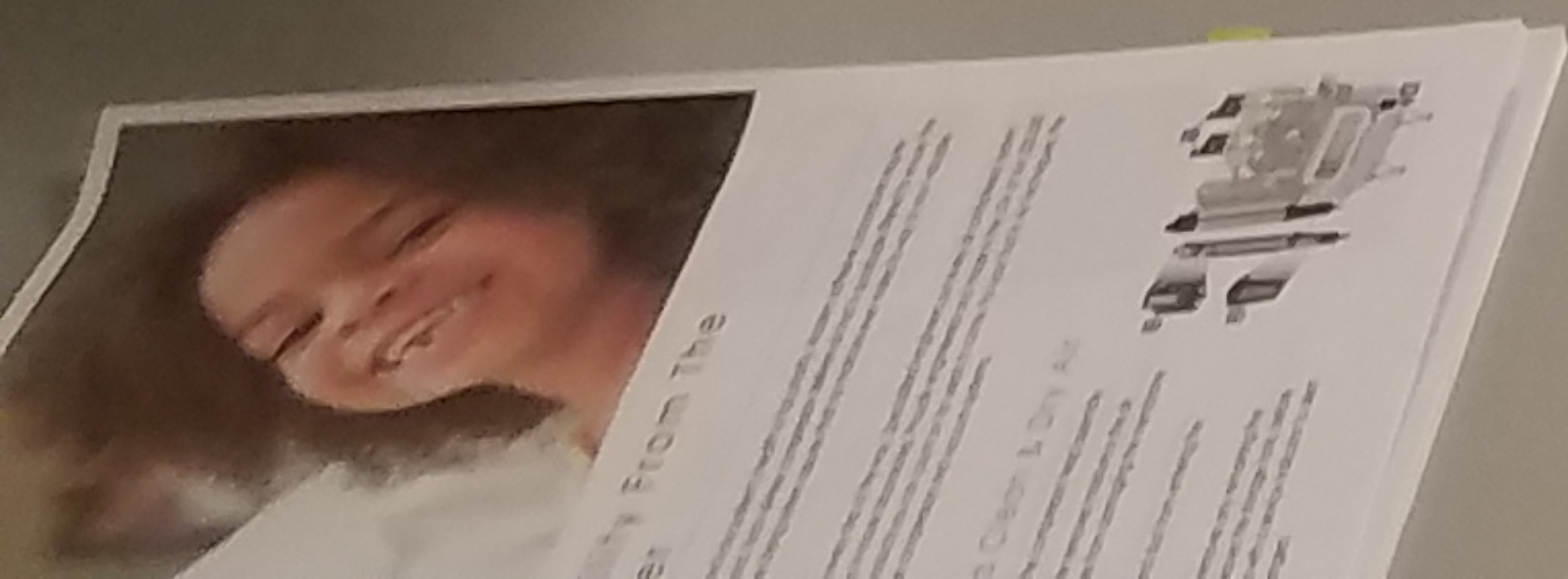

TO VERIFY AUTHENTICITY OF THIS DOCUMENT YOU MUST TURN OVER AND RUB THE DC GOV/DOH/HRLA LOGO WITH FINGER. AUTHENTIC DOCUMENT WILL CHANGE COLOR FROM ORANGE TO YELLOW

THE FACE OF THIS DOCUMENT HAS A MULTI COLORED BACKGROUND THAT CHANGES COLOR GRADUALLY AND EVENLY FROM DARK TO LIGHT WITH DARKER AREAS BOTH LEFT AND RIGHT



GOVERNMENT
OF THE
DISTRICT OF COLUMBIA

DEPARTMENT OF HEALTH
HEALTH REGULATION AND LICENSING
ADMINISTRATION

RADIATION CONTROL DIVISION
899 NORTH CAPITOL STREET, NE, 2ND FLOOR
WASHINGTON, DC 20002

CERTIFICATE
OF
LICENSURE OR REGISTRATION
REGISTRANT

HOWARD UNIVERSITY
IRB-MOLECULAR IMAGING LAB
2041 GEORGIA AVE NW
CANCER CENTER B112 WASHINGTON DC 20060

CERTIFICATE NUMBER

XY1900002

Business Activity: Medical X-Ray

Issue Date: 03/29/2019

Expiration Date: 09/30/2021

LaQuandra S. Nesbitt, MD, MPH

Director

This certificate applies only to the registrant listed herein and is not transferable on change of ownership, control, location, or business activity.

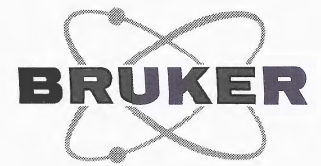

Albira Si

- Acceptance and Survey Protocol

Version 004

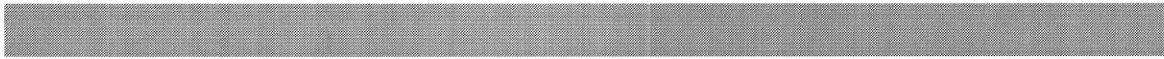

Copyright © by Bruker Corporation

All rights reserved. No part of this publication may be reproduced, stored in a retrieval system, or transmitted, in any form, or by any means without the prior consent of the publisher. Product names used are trademarks or registered trademarks of their respective holders.

This manual was written by

Bruker

© July 14, 2017 Bruker BioSpin MRI GmbH

Document Number: 9007200677430667

P/N: T160290

For further technical assistance for this product, please do not hesitate to contact your nearest BRUKER dealer or contact us directly at:

Bruker BioSpin MRI GmbH
Rudolf-Plank-Str. 23
D-76275 Ettlingen
Germany
Phone: +49 721 5161 0
E-mail: mri-hardware-support@bruker.com
Internet: www.bruker-biospin.de



Contact Information

Contact	
Contact Name, phone, e-mail	
Institution	
Address	
Address	
City, State, Zip, Country	

Instrument and Service Information

Instrument			
SAP Order #	10287104		
System Model, P/N	System S/N	1-Ring <input type="checkbox"/>	
T165256	0010	2-Ring <input checked="" type="checkbox"/>	
		3-Ring <input type="checkbox"/>	
SPECT	CT S/N	X-Ray Model, P/N	X-Ray S/N
S102 S/N _____	_____	_____	127348
S108 S/N 100/111	_____	_____	_____

Service Information	
Installed by (print Name)	LEX HURLEY DAVID OLIVAS
Install Date	1ST MARCH 2019
Warranty Begin	1ST MARCH 2019



Visual and Safety Checks

Visual Inspection		
Unit is free from manufacturing, cosmetic damage or missing parts.	<input checked="" type="checkbox"/> Pass	<input type="checkbox"/> Fail

Safety Check			
Indicators and Standby Mode Inspection	<input checked="" type="checkbox"/> Pass	<input type="checkbox"/> Fail	
Indicators and Activated Mode	<input checked="" type="checkbox"/> Pass	<input type="checkbox"/> Fail	
Indicators and X-Ray Activation	<input checked="" type="checkbox"/> Pass	<input type="checkbox"/> Fail	<input type="checkbox"/> n. a.
Indicators and the PET Module	<input checked="" type="checkbox"/> Pass	<input type="checkbox"/> Fail	<input type="checkbox"/> n. a.
Indicators and the SPECT Module	<input checked="" type="checkbox"/> Pass	<input type="checkbox"/> Fail	<input type="checkbox"/> n. a.
Indicators and Opening Doors	<input checked="" type="checkbox"/> Pass	<input type="checkbox"/> Fail	
Activation of the Emergency Stop on Front Panel	<input checked="" type="checkbox"/> Pass	<input type="checkbox"/> Fail	
Activation of the External Emergency Stop	<input checked="" type="checkbox"/> Pass	<input type="checkbox"/> Fail	
Turning off the Device	<input checked="" type="checkbox"/> Pass	<input type="checkbox"/> Fail	



Radiation Survey

Survey Meter Information			
Model <i>RADIATION ALERT RANGER</i>	S/N <i>308191</i>	Calibration Date	Calibration Due Date
Verify meter calibration qualification		<input checked="" type="checkbox"/> Pass <input type="checkbox"/> Fail	
Place the (calibrated) meter inside the instrument on audible to confirm that the X-Ray source is generating an output.			

Background Radiation		
Check background < 1 $\mu\text{Sv/h}$ (< 0.1 mrem/h)	<input checked="" type="checkbox"/> Pass	<input type="checkbox"/> Fail

Measure radiation at the surface of the points identified in the figures and record survey results in $\mu\text{Sv/h}$. Survey readings must conform to < 5 $\mu\text{Sv/h}$ (< 0.5 mrem/h) leakage.

Radiation Leakage Check	Location	$\mu\text{Sv/h}$
	1	<i>0.120</i>
	2	<i>0.120</i>
	3	<i>0.120</i>
	4	<i>0.120</i>
Cabinet Leakage at all locations < 5 $\mu\text{Sv/h}$ (< 0.5 mrem/h)	<input checked="" type="checkbox"/> Pass	<input type="checkbox"/> Fail

Albira Si
Acceptance and Survey Protocol



Radiation Leakage Check	Location	µSv/h
	5	0'120
	6	0'120
	7	0'120
	8	0'180
	9	0'240
Cabinet Leakage at all locations < 5 µSv/h (< 0.5 mrem/h)		<input checked="" type="checkbox"/> Pass <input type="checkbox"/> Fail

Radiation Leakage Check	Location	µSv/h
	10	0'120
	11	0'180
	12	0'120
	13	0'180
	14	0'240
	15	0'180
	16	0'120
	17	0'180
	18	0'180
	19	0'120
	20	0'180
	21	0'480
	22	0'120
23	0'420	
Cabinet Leakage at all locations < 5 µSv/h (< 0.5 mrem/h)		<input checked="" type="checkbox"/> Pass <input type="checkbox"/> Fail

Albira Si
Acceptance and Survey Protocol

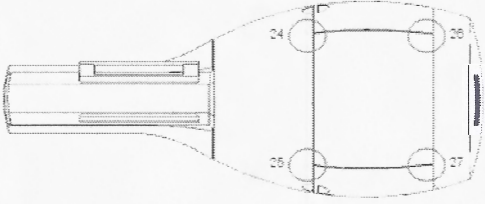

Radiation Leakage Check	Location	$\mu\text{Sv/h}$
	24	0.120
	25	0.120
	26	0.120
	27	0.120
Cabinet Leakage at all locations < 5 $\mu\text{Sv/h}$ (< 0.5 mrem/h)	<input checked="" type="checkbox"/> Pass	<input type="checkbox"/> Fail



Operational Qualification

PET				
PET global status	Photopeak	<input checked="" type="checkbox"/> Pass	<input type="checkbox"/> Fail	<input type="checkbox"/> n. a.
	Coincidences	<input checked="" type="checkbox"/> Pass	<input type="checkbox"/> Fail	<input type="checkbox"/> n. a.
	Singles	<input checked="" type="checkbox"/> Pass	<input type="checkbox"/> Fail	<input type="checkbox"/> n. a.
	Image	<input checked="" type="checkbox"/> Pass	<input type="checkbox"/> Fail	<input type="checkbox"/> n. a.
Supervisor QC	Uniformity	<input checked="" type="checkbox"/> Pass	<input type="checkbox"/> Fail	<input type="checkbox"/> n. a.
	Decompression	<input checked="" type="checkbox"/> Pass	<input type="checkbox"/> Fail	<input type="checkbox"/> n. a.
	Energy resolution	<input checked="" type="checkbox"/> Pass	<input type="checkbox"/> Fail	<input type="checkbox"/> n. a.
	Quantification	<input checked="" type="checkbox"/> Pass	<input type="checkbox"/> Fail	<input type="checkbox"/> n. a.
Fusion PET-C	Single PET-CT	<input checked="" type="checkbox"/> Pass	<input type="checkbox"/> Fail	<input type="checkbox"/> n. a.
	BED PET-CT	<input checked="" type="checkbox"/> Pass	<input type="checkbox"/> Fail	<input type="checkbox"/> n. a.
Dynamic study		<input checked="" type="checkbox"/> Pass	<input type="checkbox"/> Fail	<input type="checkbox"/> n. a.

SPECT				
Supervisor QC	Uniformity	<input checked="" type="checkbox"/> Pass	<input type="checkbox"/> Fail	<input type="checkbox"/> n. a.
	Sensitivity	<input checked="" type="checkbox"/> Pass	<input type="checkbox"/> Fail	<input type="checkbox"/> n. a.
	Energy resolution	<input checked="" type="checkbox"/> Pass	<input type="checkbox"/> Fail	<input type="checkbox"/> n. a.
	Decompression	<input checked="" type="checkbox"/> Pass	<input type="checkbox"/> Fail	<input type="checkbox"/> n. a.
Fusion SPECT-CT	Single SPECT-CT PH FOV <u>50</u>	<input checked="" type="checkbox"/> Pass	<input type="checkbox"/> Fail	<input type="checkbox"/> n. a.
	Single SPECT-CT MPH FOV <u>110</u>	<input checked="" type="checkbox"/> Pass	<input type="checkbox"/> Fail	<input type="checkbox"/> n. a.

Albira Si
Acceptance and Survey Protocol



CT				
Supervisor QC	Hounsfield Units Water	<input checked="" type="checkbox"/> Pass	<input type="checkbox"/> Fail	<input type="checkbox"/> n. a.
	Hounsfield Units Air	<input checked="" type="checkbox"/> Pass	<input type="checkbox"/> Fail	<input type="checkbox"/> n. a.
	CT Numbers Uniformity	<input checked="" type="checkbox"/> Pass	<input type="checkbox"/> Fail	<input type="checkbox"/> n. a.
	CT Numbers Slices	<input checked="" type="checkbox"/> Pass	<input type="checkbox"/> Fail	<input type="checkbox"/> n. a.
Spatial Resolution	Measure 100 μ m	<input checked="" type="checkbox"/> Pass	<input type="checkbox"/> Fail	<input type="checkbox"/> n. a.

Components			
Bed Alignment	<input checked="" type="checkbox"/> Pass	<input type="checkbox"/> Fail	<input type="checkbox"/> n. a.
Test Gated	<input type="checkbox"/> Pass	<input type="checkbox"/> Fail	<input checked="" type="checkbox"/> n. a.
Test Heater	<input type="checkbox"/> Pass	<input type="checkbox"/> Fail	<input checked="" type="checkbox"/> n. a.
Test Temperature Sensor	<input type="checkbox"/> Pass	<input type="checkbox"/> Fail	<input checked="" type="checkbox"/> n. a.
PMOD installed	<input checked="" type="checkbox"/> Pass	<input type="checkbox"/> Fail	<input type="checkbox"/> n. a.
Amide and Volview installed	<input checked="" type="checkbox"/> Pass	<input type="checkbox"/> Fail	<input type="checkbox"/> n. a.



Introduction to Product Safety

Product Safety Topics		
Introduction to the User Documentation DVD: in specific, Instructions for Use, see below:	<input checked="" type="checkbox"/> Pass	<input type="checkbox"/> Fail
Chapter Electrical Safety in general and with regard to Replacement of Parts.	<input checked="" type="checkbox"/> Pass	<input type="checkbox"/> Fail
Chapter X-Ray Safety: Inform the System Owner on Regulatory and Safety Design.	<input checked="" type="checkbox"/> Pass	<input type="checkbox"/> Fail
Chapter Chemical and Biological Safety: Inform the System Owner on Biohazard.	<input checked="" type="checkbox"/> Pass	<input type="checkbox"/> Fail
Chapter Anesthesia System: Inform the System Owner on her/his responsibility regarding Trade Product, Non-flammable gases, Worker Protection, Animal Monitoring.	<input checked="" type="checkbox"/> n. a.	
Check for mechanical tight connections of anesthesia hoses.	<input type="checkbox"/> Pass	<input type="checkbox"/> Fail
Introduction to the System Owner Documentation.	<input checked="" type="checkbox"/> Pass	<input type="checkbox"/> Fail



Acceptance



I, an authorized customer representative, acknowledge that the above referenced system was installed and demonstrated to operate in accordance with the specifications mutually agreed upon by both parties. We accept the delivery and installation of this system as complete (except for items excluded below) and release Bruker from any further obligation, other than those obligations as specified during the warranty period. With this signature, the warranty period for non-excluded items commences according to the contractual agreement.

Exclusions
ANCILLARY VALIDATION KIT ON ORDER, DAMAGED PARTS INSIDE - NOT NEEDED FOR OPERATION OF SYSTEM - ALBIRA IS READY FOR USE.
CUSTOMER IS PURCHASING AN SAI INSTRUMENTS GATING SYSTEM - BRUKER WILL RETURN TO ASSIST CUSTOMER WITH TESTING OF THEIR GATING SYSTEM - CURRENT SYSTEM WAS NOT ORDERED WITH GATING SUPPLIED

Customer Representative	Bruker Representative
Date: March 1, 2019	Date: 3-1-2019
Name: PAUL WANG	Name: REX HURLEY - DAVID OLIVAS
Signature:	Signature:



● **Bruker Corporation**

info@bruker.com
www.bruker.com

Order No: T160290