

# Technical



# Note

**TN no. N-1580**

**title:** WASTE-OIL BOILER FIRING DEMONSTRATION  
AT NWC, CHINA LAKE, CA

**author:** T. T. Fu and R. S. Chapler

**date:** June 1980

**sponsor:** Chief of Naval Material

**program nos:** Z0347-01-311B



## CIVIL ENGINEERING LABORATORY

NAVAL CONSTRUCTION BATTALION CENTER  
Port Hueneme, California 93043

Approved for public release; distribution unlimited.



Unclassified

SECURITY CLASSIFICATION OF THIS PAGE (When Data Entered)

REPORT DOCUMENTATION PAGE		READ INSTRUCTIONS BEFORE COMPLETING FORM
1. REPORT NUMBER TN-1580	2. GOVT ACCESSION NO. DN687067	3. RECIPIENT'S CATALOG NUMBER
4. TITLE (and Subtitle) WASTE-OIL BOILER FIRING DEMONSTRATION AT NWC, CHINA LAKE, CA		5. TYPE OF REPORT & PERIOD COVERED Final; Oct 1978 - Mar 1980
		6. PERFORMING ORG. REPORT NUMBER
7. AUTHOR(s) T. T. Fu and R. S. Chapler		8. CONTRACT OR GRANT NUMBER(s)
9. PERFORMING ORGANIZATION NAME AND ADDRESS CIVIL ENGINEERING LABORATORY Naval Construction Battalion Center Port Hueneme, California 93043		10. PROGRAM ELEMENT, PROJECT, TASK AREA & WORK UNIT NUMBERS Z0347-01-311B
11. CONTROLLING OFFICE NAME AND ADDRESS Chief of Naval Material Washington, DC 20360		12. REPORT DATE June 1980
		13. NUMBER OF PAGES 28
14. MONITORING AGENCY NAME & ADDRESS (if different from Controlling Office)		15. SECURITY CLASS. (of this report) Unclassified
		15a. DECLASSIFICATION/DOWNGRADING SCHEDULE
16. DISTRIBUTION STATEMENT (of this Report)  Approved for public release; distribution unlimited.		
17. DISTRIBUTION STATEMENT (of the abstract entered in Block 20, if different from Report)		
18. SUPPLEMENTARY NOTES		
19. KEY WORDS (Continue on reverse side if necessary and identify by block number)  Energy conservation, waste oils, oil-fired boilers, stack emissions, NO <sub>x</sub> , contaminated fuels, JP5, diesel fuels, No. 6 fuel oil.		
20. ABSTRACT (Continue on reverse side if necessary and identify by block number)  The waste oil generated at Naval Weapon Center (NWC), China Lake, CA was fired in a 20,000-lb/hr steam boiler at NWC to determine the operational requirements for using it as a boiler fuel. Two series of tests were conducted using blends of this waste oil and commercial grade No. 6 fuel oil normally used for NWC boilers. The first series tested batch-blended oils, while the second series an in-line blending scheme. Six thousand gallons of waste oil was consumed and 440 boiler hours covering the full range of firing conditions were logged		

DD FORM 1473  
1 JAN 73

EDITION OF 1 NOV 65 IS OBSOLETE

Unclassified (continued)

SECURITY CLASSIFICATION OF THIS PAGE (When Data Entered)

Unclassified

SECURITY CLASSIFICATION OF THIS PAGE(When Data Entered)

20. Continued

during the tests. Results show that the NWC waste oil can be satisfactorily fired either straight or in blends of any concentration with No. 6 fuel oil. Only minor adjustments to firing controls are sometimes required. No operational or environmental emission difficulties were encountered.

Library card

Civil Engineering Laboratory  
WASTE-OIL BOILER FIRING DEMONSTRATION AT NWC,  
CHINA LAKE, CA, (Final) by T. T. Fu and R. S. Chapler  
TN-1580 28 pp illus June 1980 Unclassified

1. Waste oils                      2. Oil-fired boilers                      I. Z0347-01-311B

The waste oil generated at Naval Weapon Center (NWC), China Lake, CA was fired in a 20,000-lb/hr steam boiler at NWC to determine the operational requirements for using it as a boiler fuel. Two series of tests were conducted using blends of this waste oil and commercial grade No. 6 fuel oil normally used for NWC boilers. The first series tested batch-blended oils, while the second series an in-line blending scheme. Six thousand gallons of waste oil was consumed and 440 boiler hours covering the full range of firing conditions were logged during the tests. Results show that the NWC waste oil can be satisfactorily fired either straight or in blends of any concentration with No. 6 fuel oil. Only minor adjustments to firing controls are sometimes required. No operational or environmental emission difficulties were encountered.

Unclassified

SECURITY CLASSIFICATION OF THIS PAGE(When Data Entered)

## CONTENTS

	Page
INTRODUCTION . . . . .	1
TEST FACILITY. . . . .	2
NWC WASTE OIL. . . . .	3
BOILER OPERATION . . . . .	4
Batch-Blending Tests. . . . .	4
In-Line Blending Tests. . . . .	9
DISCUSSION . . . . .	10
CONCLUSIONS. . . . .	13
RECOMMENDATIONS. . . . .	13
ACKNOWLEDGMENT . . . . .	13

## INTRODUCTION

Large quantities of waste oils are routinely generated at Navy shore facilities as a result of their normal activities. Because of the contaminants and the usually varied compositions, these oils are not suitable for regular uses. They are, however, a potential source of energy from the viewpoint of boiler fuels.

A study was made to determine the economic potential and technical requirements for utilizing the Navy's waste oils as boiler fuels. The results are reported in Technical Note N-1570.\* Briefly, up to 13% of the total fuel requirements (in natural gas, liquefied petroleum gases, and fuel oils) for Navy stationary boilers could be met by utilizing waste oils. Based on the FY79 average fuel oil price paid by the Navy, this could mean a reduction in annual fuel bills of approximately 25 million dollars.

Laboratory tests of a wide range of Navy waste oils showed that they could be satisfactorily fired in boilers in blends with regular fuel oils for waste oil concentrations up to 100%. No special requirement for firing these waste oils was necessary from the viewpoint of both environmental pollution and modifications to the existing hardware. Demonstration tests using in-service boilers at selected Navy bases were, therefore, recommended in TN-1570 to determine the handling requirements and any possible long-term effects to boiler components.

Naval Weapons Center (NWC), China Lake generates approximately 2,500 gallons of waste oils per month that is comprised primarily of contaminated JP4, JP5, and diesel fuels and used lubricating oils. The mixture of these oils is a dark colored liquid resembling light fuel oil and is somewhat heavier and higher in viscosity than diesel fuel. This material has, in the past, been used for fire fighter training and dust control. The latter use has been eliminated due to environmental restrictions, and the former can utilize only a small portion of the total available waste oil. Within these restrictions, NWC approached CEL in 1977 for assistance in utilizing the waste oil in their steam boiler plant. Because of the NWC need and the objective of CEL's waste oil utilization project, a cooperative effort was initiated.

After several planning meetings at NWC with the Public Works Personnel, Boiler no. 4 in Plant no. 1 at NWC was chosen as the test facility. The boilers in Plant 1 are fueled by interruptible natural gas and No. 6 fuel oil. Blending the NWC waste oil into No. 6 oil would provide an opportunity to test light waste oil blended in heavy fuel oils. In order to carry out this work, a test plan was prepared and a memorandum

---

\*Civil Engineering Laboratory. Technical Note N-1570: Utilization of Navy-generated waste oils as boiler fuel - Economic analysis and laboratory tests," by T. T. Fu and R. S. Chapler. Port Hueneme, Calif., Feb 1980.

of understanding between CEL and NWC was approved in July 1978. The former describes the details of the tests, and the latter outlines the responsibilities of CEL and NWC in carrying out these tests. In principle:

1. CEL would be responsible for planning and conducting the tests, preparing a report of the results, and paying for extra expenses incurred during these tests.

2. NWC would provide personnel support and wages to assist in carrying out the planned test work during normal boiler operating hours.

3. Only high flash point waste oils (e.g., used lubricating oils, contaminated JP5 and diesel fuels, etc.) would be used for the tests. Low flash point and other materials (e.g., contaminated JP4, gasoline, solvent, etc.) would be collected separately for fire fighters' training and would not be mixed with the high flash materials.

In the meantime, a fuel-handling system was installed so that Boiler no. 4 could be operated without interfering with the operation of other boilers in the plant. Two series of controlled burning tests were conducted: one during August to October, 1978, and the other during July and August, 1979. The results of these tests are described in this document.

#### TEST FACILITY

The no. 4 boiler in Plant no. 1, Building 00032, NWC is a single-burner, water-tube boiler producing 125-psi saturated steam at 20,700-lb/hr rated capacity. Steam atomization is used when firing No. 6 fuel oil. Two other identical boilers (no. 2 and no. 3) are also located in Plant no. 1. All these boilers share a fuel storage system that consists of one 100,000-gallon and two 25,000-gallon underground tanks, one pump for transferring oil between tanks, and two 30-gpm pumps for delivering the oil to the burners. For test purposes, it was necessary to isolate the fuel-handling operation for the test boiler from the others. Therefore, a separate fuel supply was installed for the test boiler. This system consists of two 450-gallon storage tanks, two steam heaters, one low-pressure recirculating pump, one high-pressure delivery pump, valves, filters, regulators, and all the associated components. The overall installation is shown schematically in Figure 1. As seen from Figure 1, by operating the appropriate valves, this system is able to take regular No. 6 fuel oil from the underground storage tank and waste oil from an outside source (e.g., a tank truck), perform blending by recirculating the oil, and deliver the oil to the burner. The physical installation of this test facility is shown in Figure 2.

A 10,000-gallon railroad tank car was used as the central collection point for the waste oils. During tests, the waste oil was first pumped out of the tank car into a tank truck, which then hauled the oil to Plant no. 1 for blending.

The existing boiler instrumentation provides for measurement of: oxygen, combustible gas, and stack gas temperature; steam flow rate; pressure and temperature of steam, feedwater, and fuel; and pressure of atomizing steam and fuel at burner nozzle. Instruments installed by CEL consisted of CO, CO<sub>2</sub>, O<sub>2</sub>, and NO analyzers, fuel and feedwater flow meters, throttling calorimeter, and thermocouples at various locations.

#### NWC WASTE OIL

Waste oils generated at various sources (excluding low flash material and solvents) were brought to the 10,000-gallon tank car in 100 to 200-gallon batches. A 10,000 gallon tank car of waste oil had been collected about 3 months before the tests were begun. This mixture of oils had been allowed to settle during the summer months. To determine the nature of this mixture, samples were drawn from the tank at five different levels. These samples were then visually examined and their gravities measured. The results are shown below along with no. 6 fuel oil for reference:

<u>Sampling Location</u>	<u>Specific Gravity at 60°F</u>	<u>Remarks</u>
Top of tank	0.871 }	No water, resembles light fuel oil
1/4 diameter from top	0.870 }	
Center of tank	1.006	Contained ~ 2/3 saline water
3/4 diameter from top	1.042 }	Practically oily saline water
Bottom of tank	1.036 }	
No. 6 fuel oil at Plant No. 1	0.959	

Clearly, this mixture contained a large amount of water and was highly nonuniform in consistency. The water in the mixture had to be removed first.

Water was drained off from the lowest point of the tank car. This was a very slow process. After 2 days, approximately 1,000 gallons of water had been removed, and the contents remaining in the tank were determined to be reasonably free of water. In order to make this oil a homogeneous material, it was recirculated between tank bottom and the far end of the tank at 15 gpm for 2 days. At the end of the recirculation period, the oil in the tank had been turned over approximately five times and was believed to be sufficiently uniform to be characterized by a single set of property values. Insignificant amounts of solids were entrapped in the filter.

Laboratory analyses of this waste oil mixture and the No. 6 fuel oil normally used in Plant no. 1 were made. The results, together with those of typical No. 2 fuel oil, are compared in Table 1.

Table 1. Properties of Oils

	NWC Waste Oil	NWC No. 6 Fuel Oil	Typical No. 2 Fuel Oil
Carbon, % wt.	86.34	85.88	87.2
Hydrogen, % wt.	12.98	11.55	12.5
Nitrogen, % wt.	0.18	0.64	0.02
Sulfur, % wt.	0.01	1.40	0.3
Oxygen, % wt. (by difference)	0.49	0.53	trace
Ash, % wt.	0.401	0.071	trace
Sediment and water, % vol.	1.0 (0.6 water)	0.2	trace
Chlorine, % wt.	trace	trace	
Flash point, °F PMCC	below room temp	220	168
Gravity, deg API at 60°F	29.9	16.1	32
Viscosity, SUS at 100°F	76	~2,200	34
Corrosion, copper strip	1B	1A	-
Gross heating value, Btu/lb	19,249	18,623	19,430

It is seen that the NWC waste oil mixture is slightly heavier and more viscous than the typical No. 2 fuel oil. Other than its color and high content of water and ash, this waste oil is quite similar to No. 2 fuel oil and is considered as a light type waste oil. This waste oil mixture was used for all the tests reported here.

## BOILER OPERATION

### Batch-Blending Tests

A series of tests was conducted between August and October, 1978, to determine the overall operational requirements for firing waste oil blends in an in-service boiler and the effects of waste oil on boiler components and stack emissions. To establish a basis for comparison, the No. 6 fuel oil normally used for this boiler was fired first; waste oil/No. 6 oil blends were then fired at increasingly higher concentrations up to 100% waste oil. Fourteen sets of tests consisting of 158 runs were conducted (5 sets in No. 6 oil, 7 sets in waste oil/No. 6 oil blends, and 2 sets in straight waste oil). The range of test conditions and data are summarized in Table 2.

For each set of these tests, approximately four firing rates were run to cover the full range of the burner capacity. During each run, the excess air (or, oxygen) in the stack gas was varied from high to low to determine the range of operable firing conditions. Stack gas was analyzed during each run. The major steps for these tests were:

1. Warm up boiler using the regular No. 6 fuel oil.
2. Adjust burner to achieve the desired constant firing rate.

Table 2. Summary of Tests of Batch-Blended Waste Oil/No. 6 Fuel Oil Mixtures (August-October 1978)

Description of Oil			Test Runs				Test Conditions				Stack Gas Measurements				
Waste Oil Conc. (% wt.)	Gravity °API @ 60°F	Viscosity SUS @ 100°F	No. of Runs	Total Time (hr)	Oil Temp (°F)	Firing Rate (lb/min)	Atom. Steam Pressure (psi)	Excess O <sub>2</sub> (% dfy)	Temp. (°F)	CO <sub>2</sub> (% dfy)	CO (ppm)	NO <sub>x</sub> (ppm)	Smoke Spot No.		
0	16.1	~2,800	5	3.0	178	8.9-11.4	52	2.8-10.2	437-523	7.7-14.4			1-8		
			12	6.4	176	8.9-17.6	45-87	1.8-9.0	418-615	8.5-15.3				1-7	
			12	5.6	194	7.9-20.9	44-79	2.8-9.3	397-617	9.1-15.6				1-9	
			11	3.3	211	7.9-20.9	47-78	2.5-8.6	397-608	5.9-15.5				1-5	
			12	4.7	184	8.4-23.6	57-78	1.3-7.4	360-495	10.5-15.5				1-10	
8.58	16.9	~1,500	14	5.5	179	8.7-21.5	45-80	2.3-10.0	401-590	8.3-14.9	0-5,000+	150-365	1-10		
			11	4.3	178	8.5-23.2	56-82	1.5-5.1	457-615	11.2-15.1				1-10	
34.7	20.4	~490	10	4.3	162	9.0-23.1	45-77	2.2-8.9	388-617	8.5-14.4	0-630	75-150	1-9		
			13	3.6	158	11.1-21.5	43-67	1.8-4.8	473-585	11.5-14.5				1-9	
50.7	23.0	264	13	3.8	105	9.9-23.0	44-73	2.1-10.2	397-608	8.4-16.8		93-265	1-9		
74.8	26.3	127	10	3.6	80	6.7-21.9	46-60	3.0-8.9	400-601	10-15.4		60-98	1-9		
89.6	28.4	89	13	4.0	76	8.6-19.9	42-45	3.6-8.6	412-601	9.5-14.0		55-230	1-9		
100	29.9	76	17	4.3	87	11.1-17.6	37-47	2.5-6.2	440-579	11.1-13.8	0-1,100	45-79	1-10		
			5	2.0	78	17.7-19.7	46-50	6.1-8.3	536-583	10.6-13.0		70-100	35-40	3-9	

3. Prepare waste oil/No. 6 oil blend. (This was usually done late in the afternoon after a set of tests was completed.) The waste oil was first hauled from the tank car storage to Plant No. 1 by a truck. Waste oil and No. 6 fuel oil were then pumped from the truck and the underground fuel storage tank, respectively, into the 450-gallon blending tank in the desired proportion. This mixture was then recirculated in the tank overnight at the rate of 30 gpm. By the next morning this mixture would have been turned over more than 100 times.

4. Set oil heating controller to temperature which would result in a blended oil viscosity near that of the No. 6 oil at its normal firing temperature.

5. Switch burner from regular fuel oil to waste oil blend and maintain a fixed firing rate.

6. Set combustion air flow as high as possible without producing an unstable flame.

7. After combustion and boiler output have stabilized, record stack gas temperature,  $O_2$ ,  $CO$ ,  $CO_2$ ,  $NO_x$ , smoke spot number, fuel flow rate, etc.

8. Decrease combustion air flow in a stepwise manner while maintaining the firing rate, and repeat step 7.

9. Repeat step 8 until the smoke spot number reaches an unacceptable level. (Further decrease of air from this point will cause smoky flame and/or flame impingement in the furnace).

10. Change firing rate, and repeat steps 6 through 9.

11. Repeat step 10 until completion of four firing rates to cover the full range of boiler operation.

During these tests, the steam quality was measured periodically using a throttling calorimeter. The steam produced was found to be consistently between 1.5% and 2% moisture. Since this information was not essential for evaluation of a fuel, this measurement was discontinued shortly afterwards.

In order to demonstrate the feasibility of burning waste oils, one is only interested in whether or not burning waste oil or its blends with regular fuel oil will introduce additional emissions. If the emission level is the same as or lower than that from burning regular fuel oil, the waste oil will be considered equal to or better than the regular fuel oil from an emission standpoint.

For practical and safety reasons, the air supplied to a combustion process must always be higher than that theoretically required. This extra amount of air is called "excess air," which is normally expressed in terms of the theoretical air, and is easily determined from the concentration of oxygen in the stack gas. Therefore, most of the data obtained are presented in terms of the stack gas oxygen concentration.\* The results are described below:

---

\*Data presented here are characteristic of the particular hardware and, therefore, must not be considered for general use. They serve the purpose of demonstrating the performance of waste oils when used in a regular fuel system, however.

Fuel Flow. The fuel flow rate increases with the available pressure head. This relationship for the burner of the test boiler is shown in Figure 3. It is seen that the flow behavior of waste oil blends is similar to that of the regular No. 6 fuel oil, except that waste oil blends achieve higher flow rates than No. 6 oil; the higher the waste oil concentration, the higher the flow rate. This result was expected because the waste oil tested had a much lower viscosity than the No. 6 oil and blending resulted in a lower viscosity of the mixture. At the same pressure, low viscosity is associated with high flow rate. In order to maintain reasonable flow rates, room temperature firing was required when waste oil concentrations were  $\geq 75\%$ .

Nitrogen Oxides. Nitrogen oxides or  $\text{NO}_x$  emission is one of the principal environmental constraint in boiler operation. For a given burner device,  $\text{NO}_x$  formation depends, among others, on flame temperature or firing intensity, nitrogen content of the fuel, and the excess air or oxygen. The  $\text{NO}_x$  data obtained are plotted against the stack gas oxygen concentration as shown in Figure 4. This figure shows that the  $\text{NO}_x$  emission for waste oil blends: (1) decreases as the waste oil concentration increases, (2) appears to be insensitive to oxygen concentration or excess air, and (3) is generally lower than that of No. 6 oil except at 10% waste oil concentration. These results may be qualitatively explained as follows:

- (1) The NWC waste oil is a low-nitrogen fuel compared to the high nitrogen No. 6 oil (see Table 1). Their blends will have a lower nitrogen content than the No. 6 oil and, consequently, lower  $\text{NO}_x$  will be formed.
- (2) The low firing intensity (low temperature steam and large furnace volume) causes minimal  $\text{NO}_x$  formation and, hence, insensitivity to other affecting parameters, such as excess air.
- (3) The higher  $\text{NO}_x$  emission level experienced with the 10% blends is unexplainable at the present.

Smoke. Smoke is a visual environmental constraint in boiler operation. The smoke levels for these tests are indicated by the Bacharach smoke spot number as shown in Figure 5. For greater clarity the data points for burning waste oil are plotted using the envelope (or ranges) of data obtained for No. 6 oil as a reference. It is seen that most of the waste oil data fall within the envelope. The data show also that it was possible to operate the burner at the same level of oxygen (or excess air) but at different levels of smoke. This means that it is possible to operate the boiler at low excess air simultaneously with low smoke emission. Human factors are clearly involved. In order to insure efficient boiler operation, careful attention by the boiler operator or by using automatic monitoring devices is necessary. Visual observations were also made of the stack gas. For waste oil concentrations  $\geq 50\%$ , visible white smoke was noted. Because of this color, the smoke spot number data are sometimes misleading when used to relate to particulate emission. No clear stack condition could be achieved through an increase in excess air (or  $\text{O}_2$ ). Decreasing  $\text{O}_2$  caused darkening of the smoke from white to tan, to brown, to dark brown.

Carbon Monoxide. Carbon monoxide (CO) is a health hazard. It is also an indicator of the completeness of combustion. For these reasons, it is important to minimize CO emission. Due to instrumentation malfunction during the tests, only four sets of CO data were obtained as shown in Figure 6. Note that except at 100% waste oil, the CO levels for 10% and 30% waste oil blends are comparable and generally lower than that for No. 6 oil.

Incomplete combustion may be associated with low flame temperature which in turn may affect the NO<sub>x</sub> formation. In this sense, the high CO level in Figure 6 and low NO<sub>x</sub> level in Figure 4 for 100% waste oil firing appear to be consistent. This suggests that the waste oil tested may have had a tendency to impede complete combustion (attributable to the particular contaminants and additives in the oils). This effect is not environmentally significant and therefore is of no concern.

Carbon Dioxide. Carbon dioxide (CO<sub>2</sub>) is the primary indicator of the degree of complete combustion and of the amount of excess combustion air supplied. It is traditionally used as a measure of boiler efficiency: higher CO<sub>2</sub> means higher efficiency. Since any value of CO<sub>2</sub> below the theoretical maximum for a given fuel may be a result of either incomplete combustion or excess air, to eliminate confusion excess air (O<sub>2</sub>) becomes a more desirable parameter for monitoring boiler operation. There is a unique relationship between the O<sub>2</sub> and CO<sub>2</sub> concentrations in the combustion products for a given fuel. Therefore, CO<sub>2</sub> may be used as a means to verify the O<sub>2</sub> data and vice versa. Using the compositions of the NWC waste oil and No. 6 oil, the relationships between CO<sub>2</sub> and O<sub>2</sub> were computed and superimposed on the test data as shown in Figure 7. The agreement is satisfactory considering data scatter and experimental errors.

Stack Gas Temperature. Stack gas temperature is a measure of the amount of energy that is carried away by the stack gas (energy wasted). Thus, within practical limits, boilers should be operated at minimal stack gas temperature. This may be achieved through adjustment of the burner and other various boiler controls. A large number of data reflecting the various burner and damper settings were obtained. These data are presented in Figure 8 in the same manner as for the smoke emission (Figure 5). Note that stack gas temperature is also a controllable item. Continuous attention of the boiler operator or the use of some automatic monitoring and control devices would be helpful in achieving high operating efficiency of the boiler.

Overall Appearance. Observations were made on an overall basis of the boiler during and after the tests. All of the equipment functioned normally without requiring special attention. As expected, no difficulties were encountered.

Since the NWC waste oil has a relatively high ash content, in order to determine the extent of ash deposition on boiler tubes, no soot blowing was done during the entire period of tests.\* After the tests, inspection doors near the stack area were opened. The boiler tubes appeared to be clean; there was some loose, grayish white deposit (ash)

---

\*Soot blowing is normally done twice each shift when firing No. 6 oil.

on horizontally oriented boiler tubes. The amount of this ash was insignificant and appeared similar to the condition after normal soot blowing during No. 6 oil firing. No black soot particles were visible, and horizontal structural surfaces appeared to be reasonably clean. The burner nozzle was also inspected after the tests and the nozzle tip, which usually requires routine cleaning to remove carbon deposits, was clean. The condition of the nozzle tip after firing waste oil and No. 6 oil is shown in Figure 9.

Clearly, the NWC waste oil mixture resulted in clean burning, both at the nozzle tip and in the fire-side flow passages. Soot formation appeared to be minimal. This result was somewhat expected because the NWC waste oil tested was merely the mixture of a number of high quality materials (relative to the lowest grade fuel oil, No. 6 oil). This implies that cleaner combustion will result when the blend is of higher quality than the regular fuel oil.

In summary, the NWC waste oil is a high quality material relative to the regular No. 6 oil. Batch-blending tests show that the results are predictable and no special attention is required to burn the waste oil, either in blends or straight, except to adjust the temperature of the blend so that its viscosity is nearly the same as that of the regular fuel oil. No component malfunction or extra operational problems were encountered. The waste oil was considered as a good source of boiler fuel.

Since batch blending is not practical for routine boiler operations, a less involved blending scheme, e.g., in-line blending, would greatly simplify the entire operation. This method of blending was tested and is described in the next section.

### In-Line Blending Tests

In-line blending is simple. If this method is proven to be practical, field activities can readily implement a waste oil boiler firing program with minimal effort and expense. The purpose of the tests described here was, therefore, to determine the additional requirements, if any, for the in-line blending method during normal (routine) boiler operations. Since the combustion characteristics of the NWC waste oil were already known from the batch-blending tests, no special effort was made to monitor stack emission and operating conditions. That is, the boiler would be fired with a waste oil blend (at a fixed concentration setting) to meet the normal steam demand in the same manner as for regular No. 6 fuel oil.

For the tests described here, the existing waste oil blending and supply system (Figure 1) was used with a minor modification: a needle valve was installed immediately downstream of the waste oil shutoff valve, V1, to accurately control waste oil flow. A thermocouple was also installed to measure the oil temperature near the burner nozzle. Since the NWC waste oil was a low viscosity material (see Table 1), heating was unnecessary; the system functioned practically as a waste oil storage and delivery system.

The tests began on July 20 and ended on August 11, 1979. For these tests the needle valve was opened to a fixed setting to obtain a blend of approximately 9% waste oil concentration. During the last 30 hours of the test, the needle valve opening was increased so that the waste oil concentration was approximately doubled. Some figures of interest are summarized below:

Total boiler time: 384 hr  
Approximate average firing rate: 110 gal/hr  
Average steam production rate: 14,400 lb/hr (or 80% capacity)  
Average waste oil concentration: 10%  
Total waste oil consumed: 4,000 gal  
Waste oil supply pressure: 180 psig  
No. 6 fuel oil header pressure: 115 psig

During the test period, there were several shutdowns for recharging the waste oil tank and once for replacing a broken pressure gage. No difficulties were encountered during the entire period of testing, nor were there any special requirements arising from use of the waste oil blend.

Although no special attempt was made to monitor the operating conditions and stack emission, a spectrum of such data was obtained at the beginning of the tests to insure that the system was performing normally. The results are shown in Table 3.

In summary, experience gained thus far shows that in-line blending is simple to implement and works satisfactorily. For waste oil concentrations up to 18%, the blend can be fired the same as regular fuel oil in every respect.

## DISCUSSION

Waste oil affects the viscosity of the blend and, hence, the fuel flow rate and nozzle spray characteristics. Fluctuating firing rate and spray patterns are undesirable. In order to minimize this possibility, it is necessary to monitor the concentration of waste oil in the blend during in-line blending. For the in-line blending tests reported here, the concentration was estimated from the firing rate and the regression rate of the waste oil level in the storage tank. This method can be rather time-consuming because the regression rate during these tests was less than 1 in./hr. A simple real-time method would clearly be desirable for boiler plant operators. Three methods are discussed below:

1. Specific Gravity Method. Let  $\gamma_1$ ,  $\gamma_2$ , and  $\gamma_3$  be the specific gravity, respectively, of the regular fuel oil, waste oil, and their blend at the same temperature. Assuming constant volume mixing, the waste oil concentration would be:

$$x = \frac{\gamma_3 - \gamma_1}{\gamma_2 - \gamma_1}$$

For this method, an ordinary hydrometer, a glass cylinder, and a sampling port close to the burner nozzle in the fuel system would be required. This is a one-time measurement, but the accuracy is good, the procedure is simple, and the initial investment is minimal. The accuracy of this method increases with the difference between  $\gamma_1$  and  $\gamma_2$ .

2. Temperature Method. Let  $T_1$ ,  $T_2$ , and  $T_3$  be the temperatures, respectively, for the regular fuel oil, waste oil, and their blend. If these temperatures are measured at locations fairly close to one another, and assuming that the specific heats of the oils are the same and the mixing takes place adiabatically, by conservation of energy, the waste oil concentration would be calculated as follows:

$$x = \frac{T_3 - T_1}{T_2 - T_1}$$

Some inherent errors exist due to the assumptions used. This method is ideal, however, for continuous monitoring if automatic recording devices are used, and it is, keeping in mind the possible errors, particularly helpful when blending oils of nearly equal specific gravities.

3. API Gravity Method. This method is essentially the same as for the specific gravity method except that an API hydrometer is used. API gravity is defined as

$$\text{Degree API Gravity} = \frac{141.5}{\text{Specific Gravity of } 60^\circ\text{F}} - 131.5$$

Due to the artificiality built into this definition, the formula for calculating the concentration is unnecessarily complicated. Let  $G_1$ ,  $G_2$ , and  $G_3$  be the API gravity, respectively, of the regular fuel oil, waste oil, and their blend:

$$x = \frac{G_1 - G_3}{G_1 - G_2} \left( \frac{G_2 + 131.5}{G_3 + 131.5} \right)$$

The API gravity is a quantity derived from specific gravity. Since the amount of work in measuring  $G$  is the same as in measuring  $\gamma$ , there is little justification for using this method.

Table 3. Stack Emissions From Firing In-Line Blended NWC Waste Oil and No. 6 Oil

Steam Load (lb/hr)	Burner Conditions			Stack Gas Analyses							Estimated Boiler Efficiency (%)
	Fuel Temp. (°F)	Nozzle Pressure (psig)	Atom. Steam (psig)	Temp. (°F)	O <sub>2</sub> (%)	CO <sub>2</sub> (%)	CO (ppm)	NO <sub>x</sub> (ppm)	Smoke Spot No.		
5,500	194	20	40	390	7.5	10.3	26	185	1.5	83	
6,000	189	20	42	400	7.2	10.5	70	215	-	83	
9,000	192	-	-	430	5.5	10.8	89	205	1.5	82	
11,500	195	41	59	475	5.9	10.8	88	195	2	81	
14,000	193	38	57	490	4.6	11.2	108	182	2	81	
16,000	187	61	75	520	4.3	11.5	120	193	4	81	
17,000	182	58	72	530	4.0	11.6	140	180	5	80	
19,000	182	64	75	540	3.2	11.8	163	183	5	79	

- Notes:
1. The overall average waste oil concentration was 10%.
  2. All gas analyses are on a dry basis.
  3. Boiler efficiency is estimated based on stack gas temperature and CO<sub>2</sub> concentration.
  4. These data are characteristic of the particular burner and the boiler components during routine operations. No adjustment was made during the test.
  5. The temperature of the No. 6 oil was 187-200°F before blending. The waste oil was at the actual ambient temperature, 87-91°F. These resulted in the temperature variations of the blend and also to some extent the waste oil concentration of the blend.

## CONCLUSIONS

The NWC waste oil resembles a light grade fuel oil. After removal of water and solid contaminants, this waste oil can be satisfactorily fired in boilers, either straight or in blends of any concentration with the regular No. 6 fuel oil. To minimize the requirement for burner adjustments, the firing temperature of a blend should be controlled so that its viscosity is as nearly the same as that of the regular fuel oil at its normal firing temperature. No operational or environmental emission difficulties were encountered due to the presence of waste oil during either batch or in-line blending tests. In-line blending was successfully achieved by combining two oil streams using a "T" arrangement.

## RECOMMENDATIONS

Sufficient experimental evidence shows that the NWC waste oil is a satisfactory boiler fuel or fuel supplement. Therefore, routine firing of this waste oil in Boiler Plant no. 2 is recommended. Since the amount of waste oil generated at NWC is relatively small compared with the fuel oil consumption, low concentration firing (~10%) is recommended. A proposed waste oil supply and blending scheme is shown schematically in Figure 10. In this scheme, the waste oil is introduced into the suction side of the main fuel pump of the existing system to insure thorough mixing. Temperatures are taken at three locations, and a sampling port is provided downstream of the pump so that the waste oil concentration can be measured by either the "Temperature Method" and/or the "Gravity Method". The low pressure pump near the waste oil tank is intended for stirring the waste oils in the tank to insure a homogeneous material. It will not be used during actual boiler operation.

## ACKNOWLEDGMENT

Contributions to planning and conducting the tests are gratefully acknowledged for NWC, China Lake, Public Works Office personnel: Messrs. George Clark, John Dollman, Wayne Jackson, and Larry Mosby. The Navy Environmental Support Office of CBC, Port Hueneme, provided and installed instrumentation for measurement of boiler stack gas emissions. Mr. Mike Thomas of the Civil Engineering Laboratory assisted in timely completion of the tests.

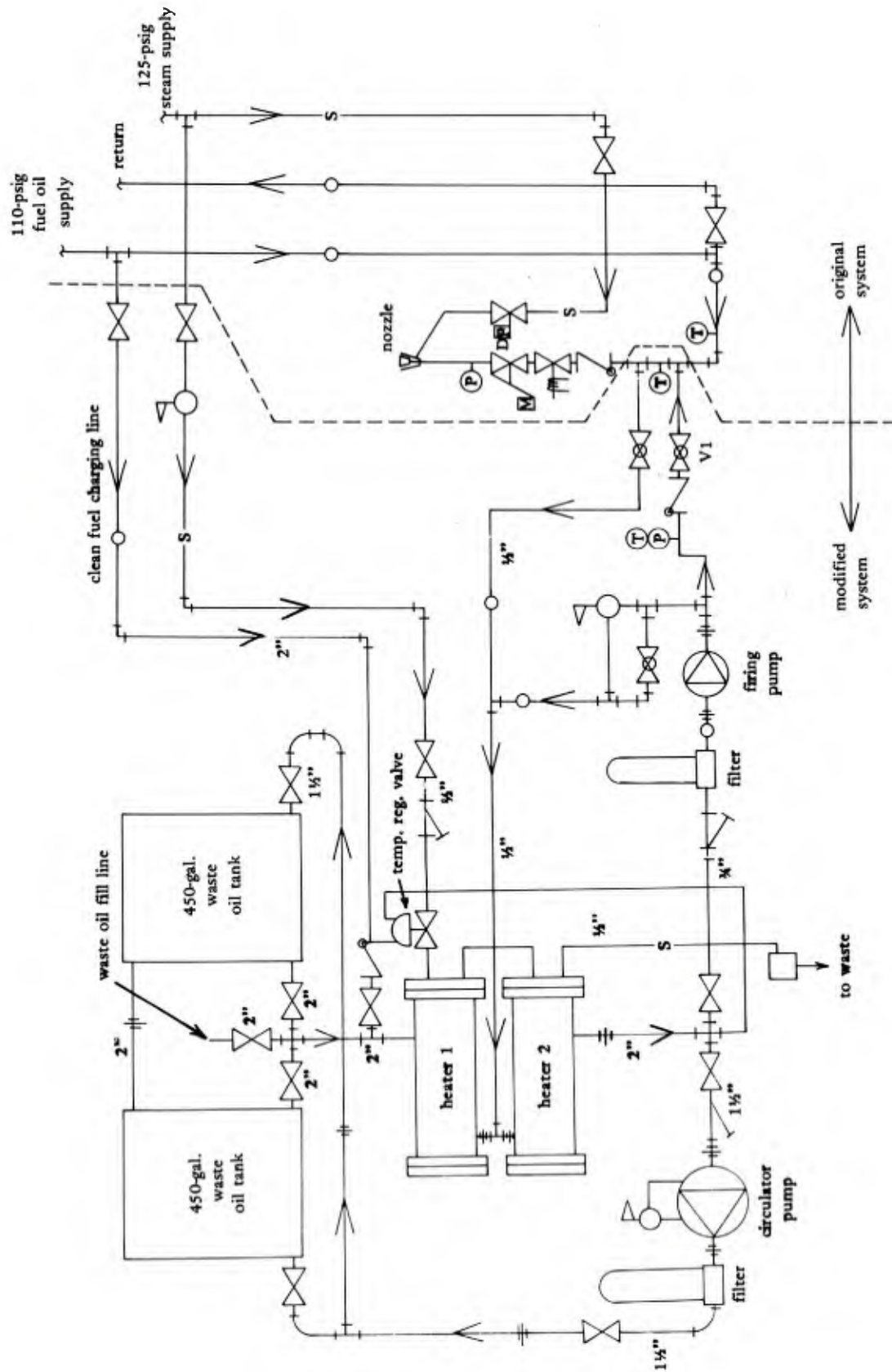
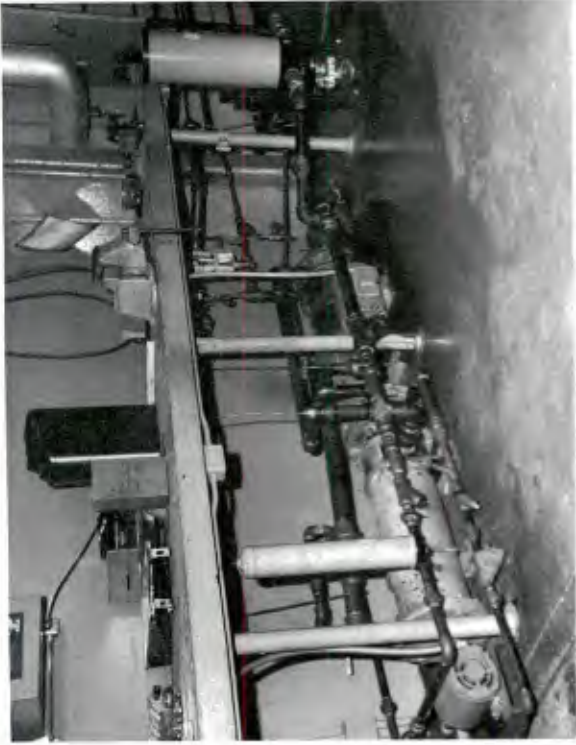

Figure 1. Waste oil blend supply system for boiler plant No. 1 at NWC, China Lake.



a. Blending and storage tanks (shown partially insulated).



b. Pumps, heaters, filters, and controls.

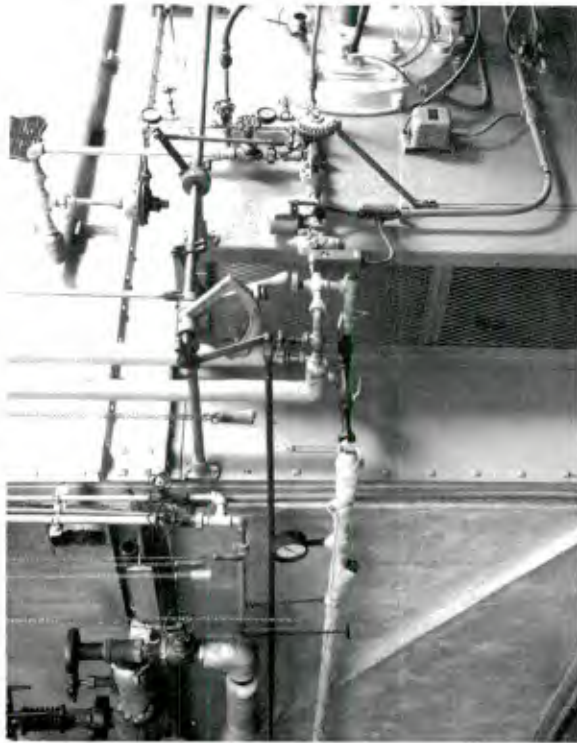

c. Boiler front face.



d. Burner.

Figure 2. Test facility.

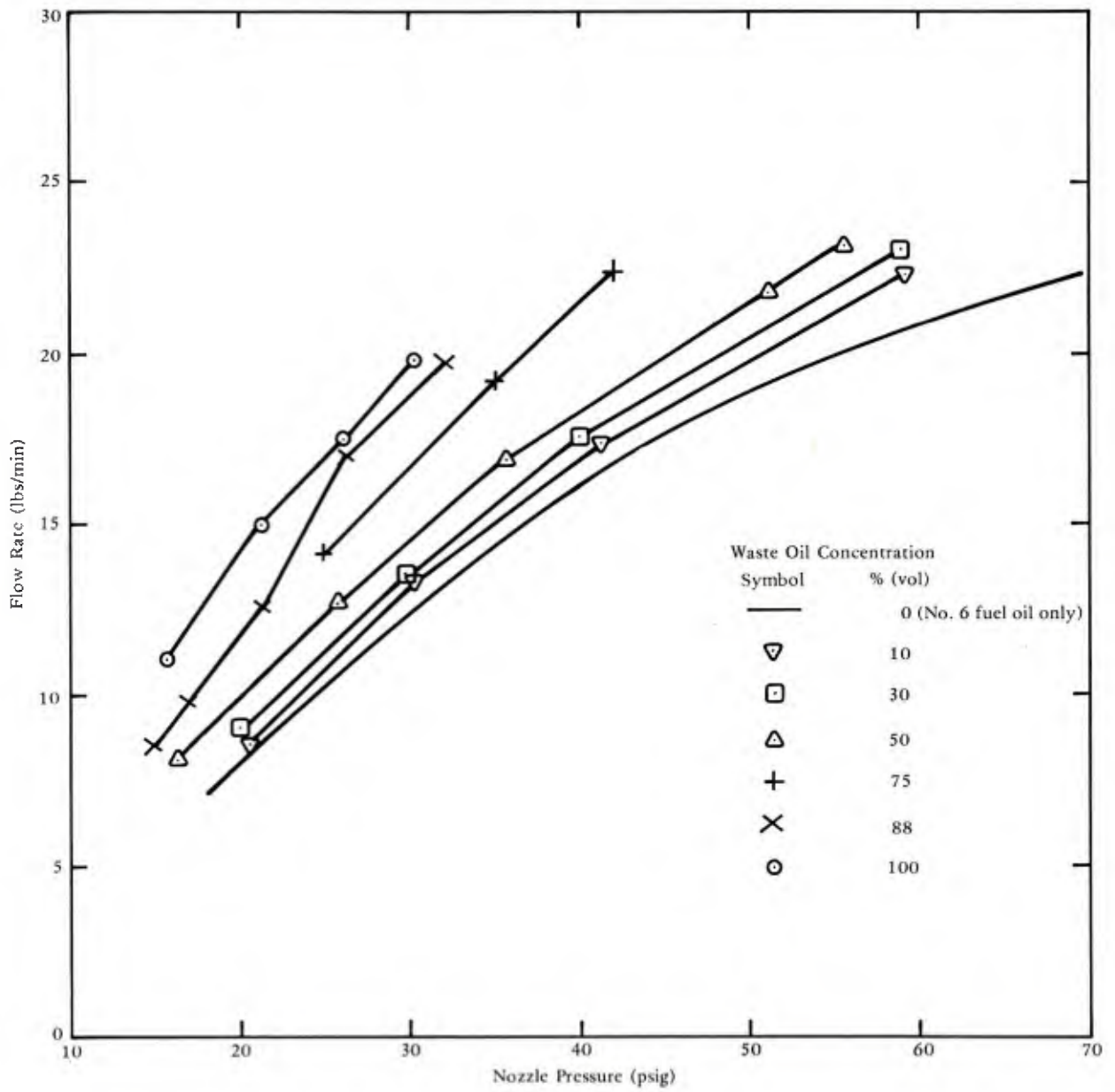

Figure 3. Fuel flow rate.

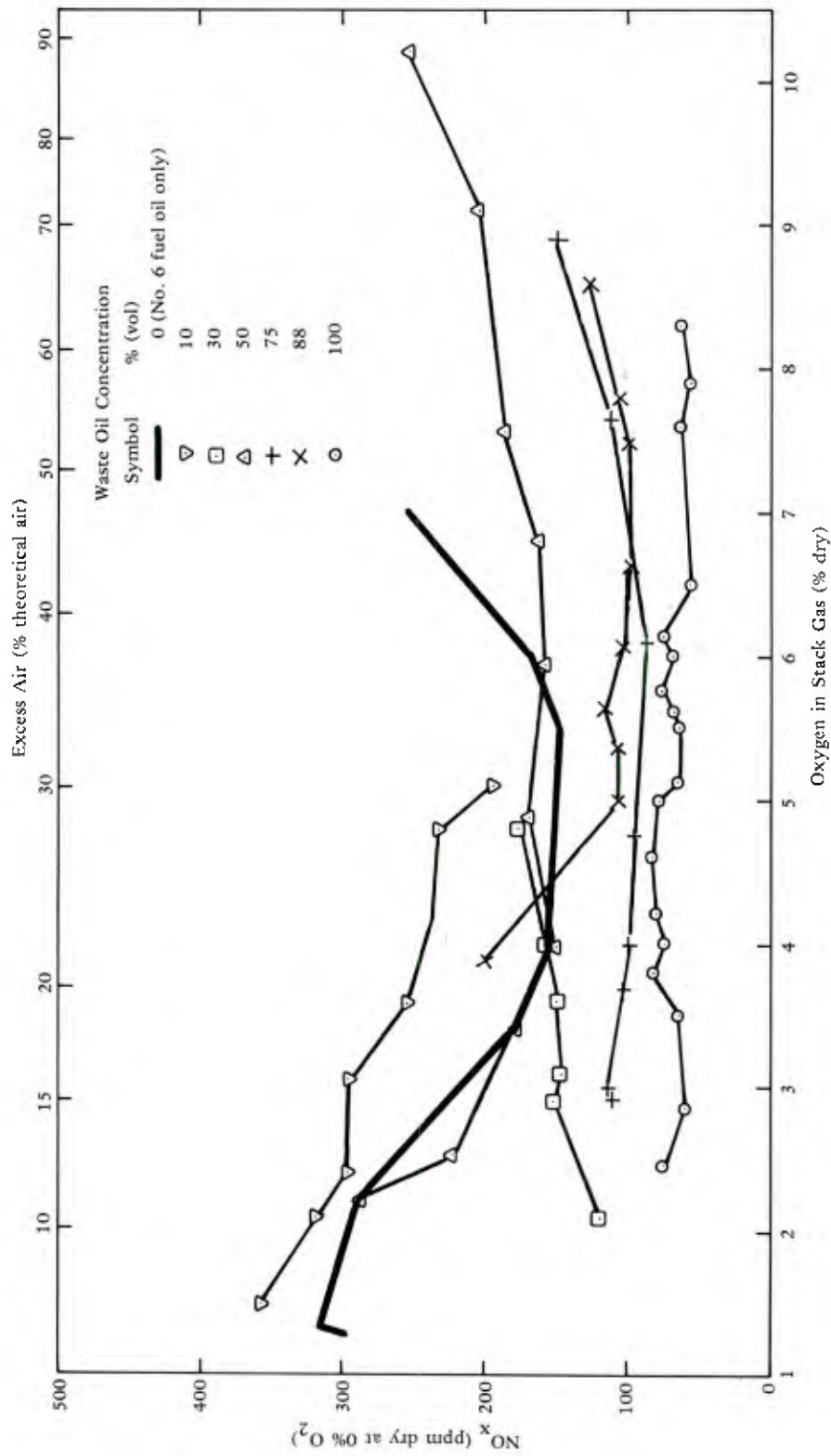

Figure 4. NO<sub>x</sub> emissions.

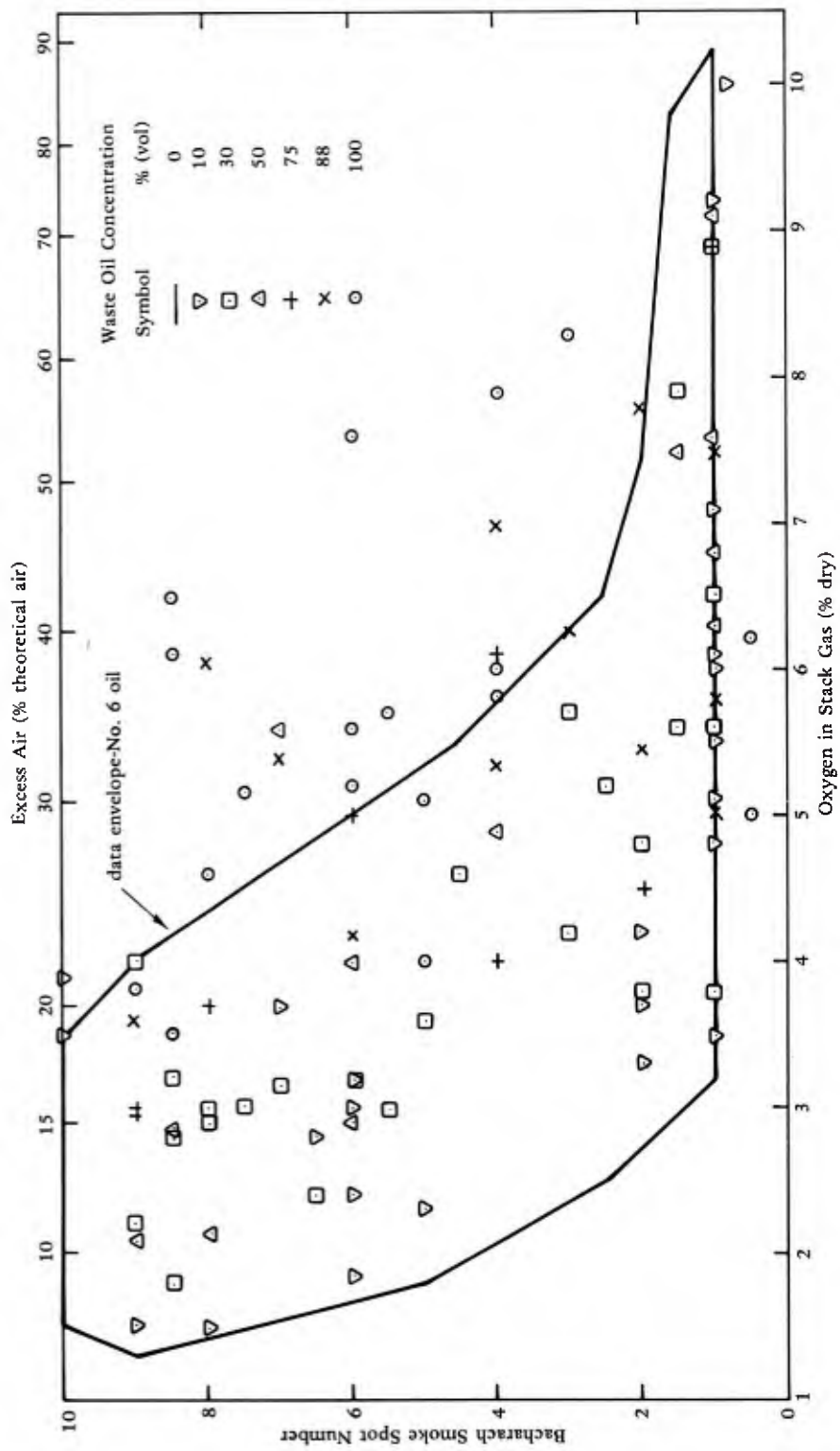

Figure 5. Smoke emissions.

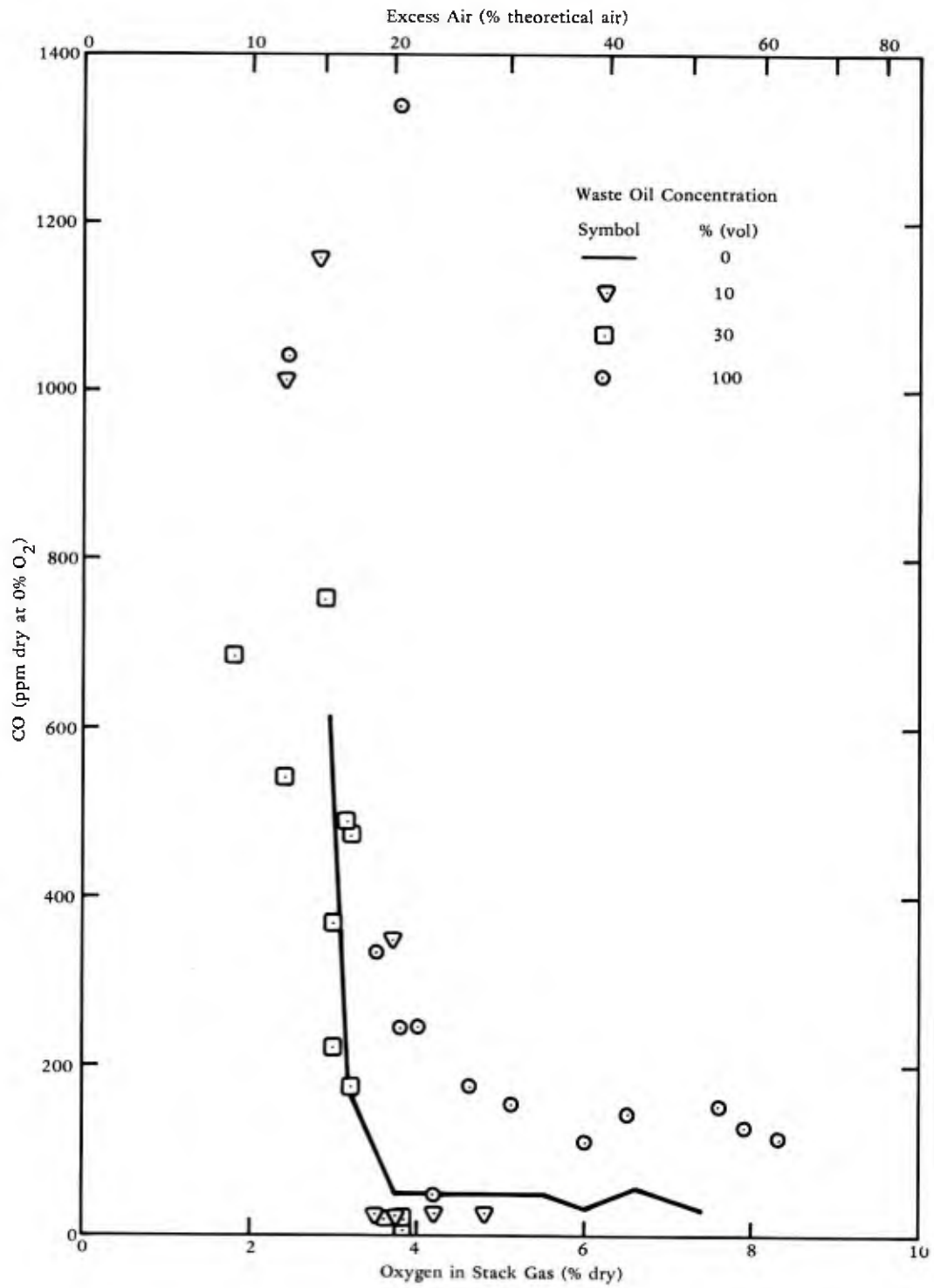

Figure 6. Carbon monoxide emissions.

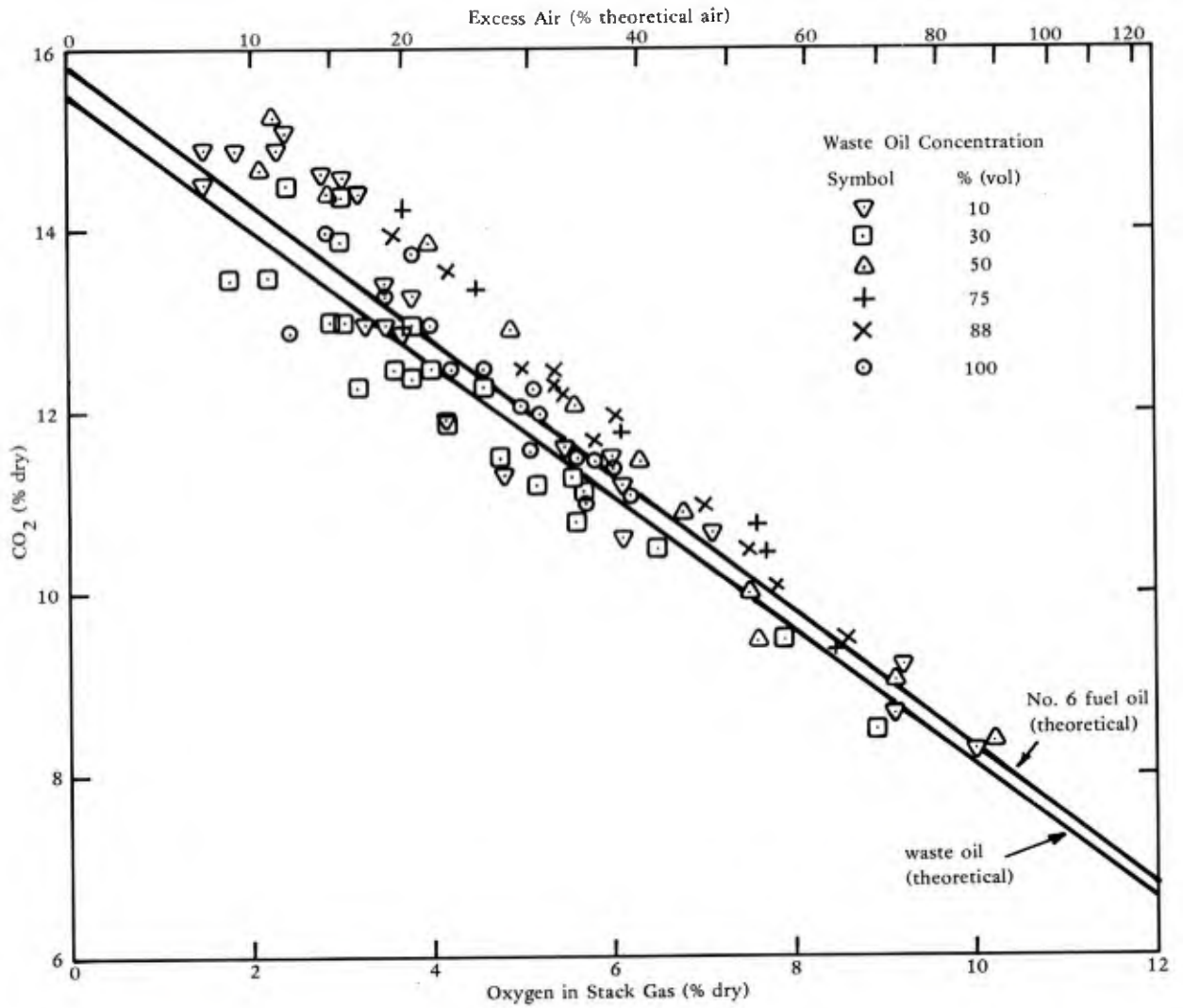

Figure 7. Comparison between theoretical and experimental values of CO<sub>2</sub> - O<sub>2</sub> relationship.

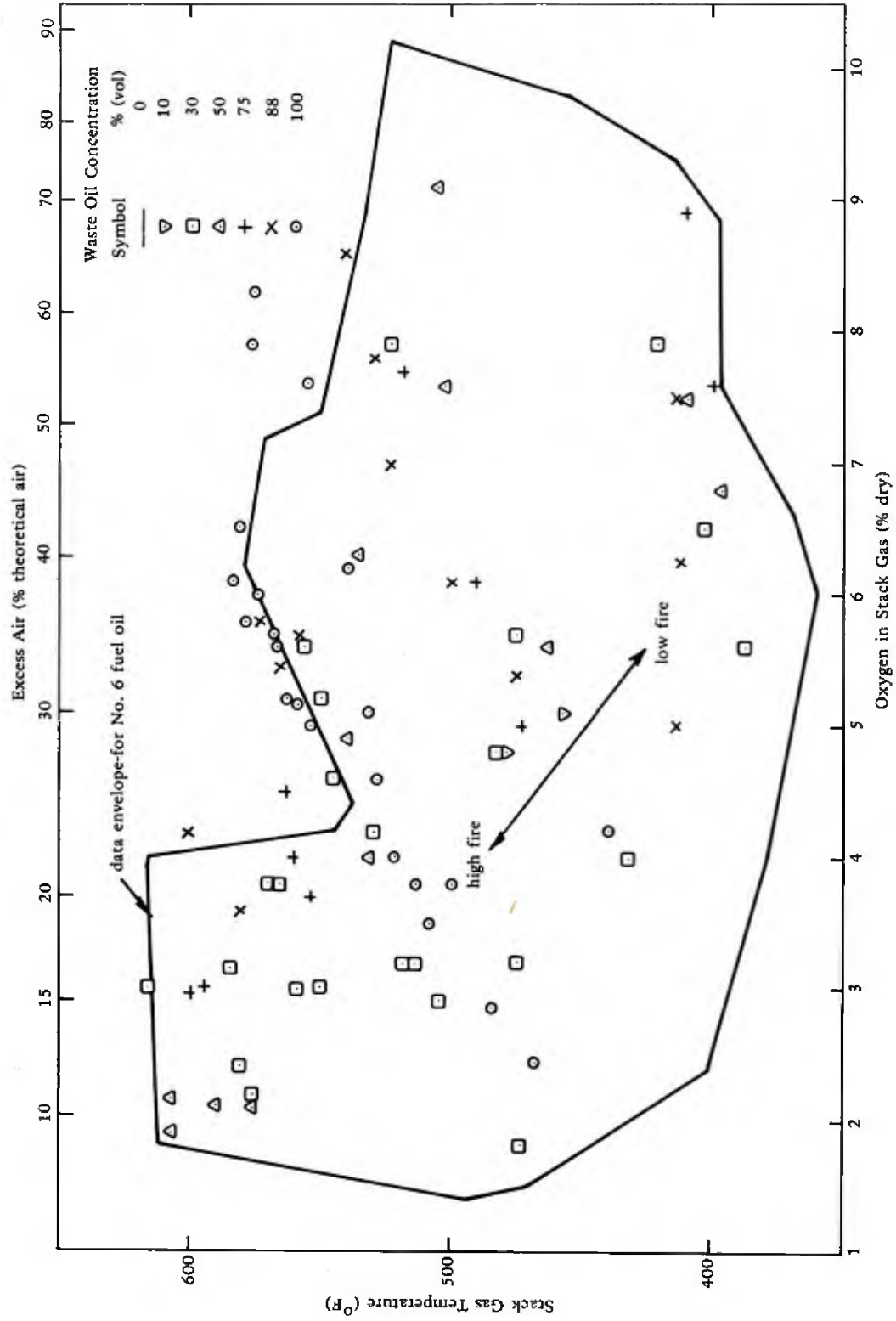
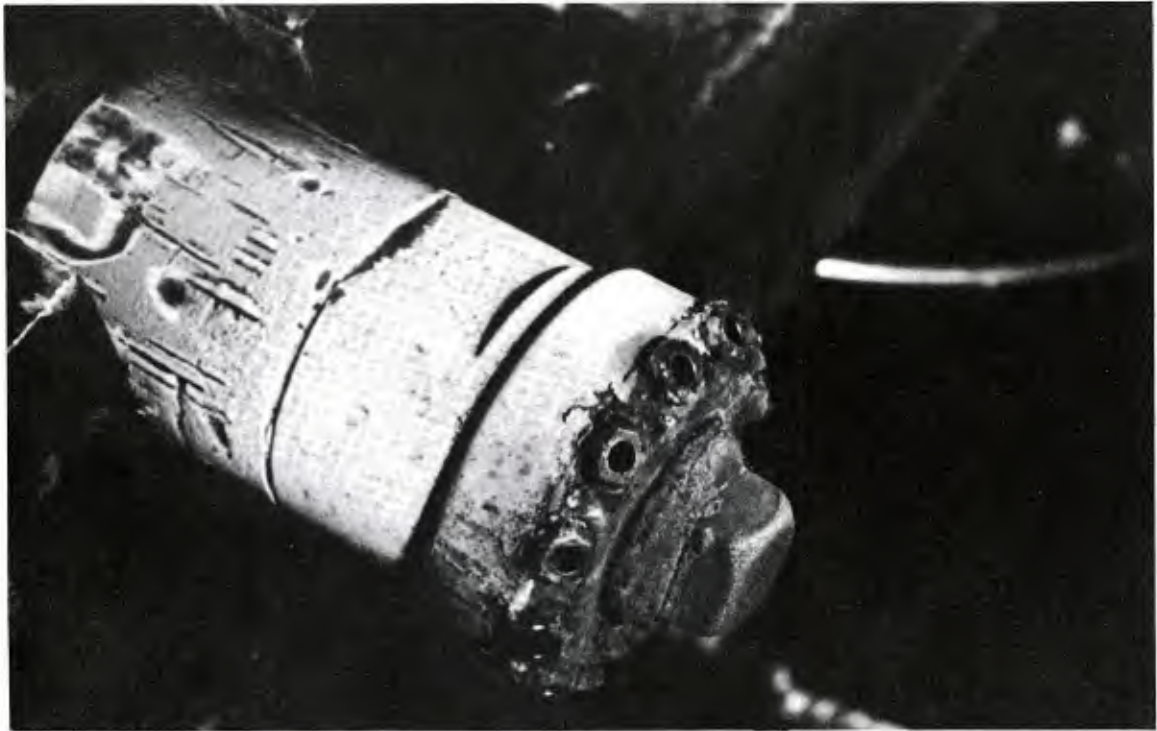

Figure 8. Stack gas temperature.



a. After 30 hours firing waste oil/no. 6 fuel oil blends at various concentrations.



b. After 18 hours of firing no. 6 fuel oil.

Figure 9. Condition of nozzle tips.

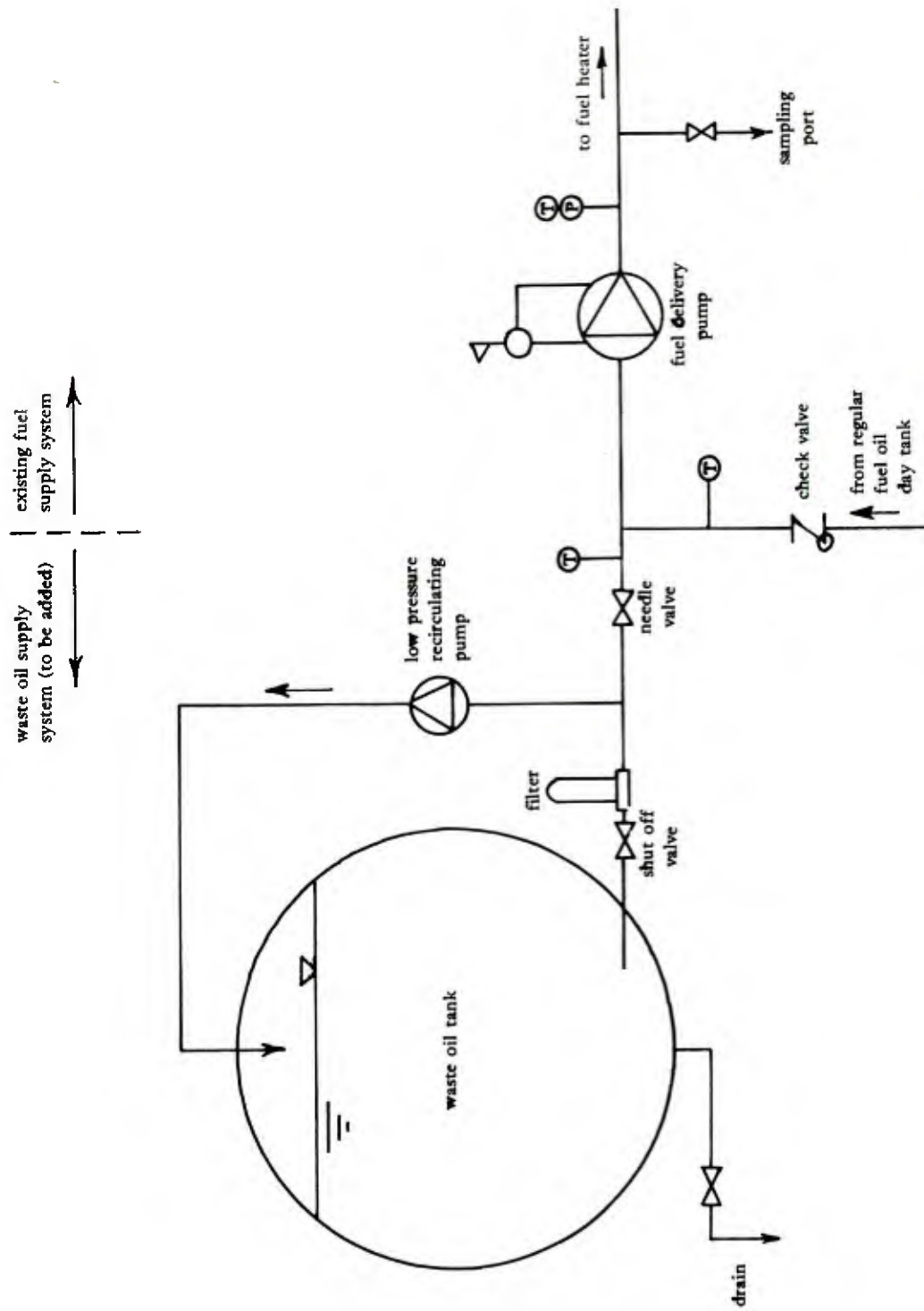

Figure 10. A proposed scheme for in-line blending of waste oil with regular fuel oil at NWC Boiler Plant No. 2.

## DISTRIBUTION LIST

AAP NAVORDSTA IND HD DET PWO (Code 092) McAlester OK  
AF HQ AF/LEY Washington, DC  
AFB (AFIT/LD), Wright-Patterson OH; ABG/DEE (F. Nethers), Goodfellow AFB TX; AERO Propulsion Lab  
(Energy Conv) Wright Patterson OH; AF Tech Office (Mgt & Ops), Tyndall, FL; AFCEC/XR, Tyndall FL;  
AFETO/DOSE, Tyndall AFB, FL; CESCH, Wright-Patterson; HQ Tactical Air Cmd (R. E. Fisher), Langley  
AFB VA; MAC/DET (Col. P. Thompson) Scott, IL; SAMSO/MNND, Norton AFB CA; Samso,  
Vandenburg, AFB, CA; Stinfo Library, Offutt NE; (LT Acero), McGuire AFB, NJ  
ARMY (SAIL-FM) OSA Washington, DC; BMDSC-RE (H. McClellan) Huntsville AL; DAEN-CWE-M (LT C  
D Binning), Washington DC; DAEN-FEU-E (J. Ronan), Washington DC; DAEN-MPE-D Washington DC;  
DAEN-MPU, Washington DC; ERADCOM Tech Supp Dir. (DELS-D) Ft. Monmouth, NJ; Engr District  
(Memphis) Library, Memphis TN; Install Support Europe, AEUES-RP APO New York; Tech. Ref. Div.,  
Fort Huachuca, AZ  
ARMY - CERL Library, Champaign IL  
ARMY AMMUNITION PLANT Sarhw - FEM Hawthorne, NY  
ARMY COASTAL ENGR RSCH CEN Fort Belvoir VA  
ARMY CORPS OF ENGINEERS MRD-Eng. Div., Omaha NE; Seattle Dist. Library, Seattle WA  
ARMY CRREL G. Phetteplace Hanover, NH  
ARMY DARCOM AMCPM-CS (J. Carr), Alexandria VA  
ARMY ENG DIV HNDED-CS, Huntsville AL; HNDED-SR, Huntsville, AL  
ARMY ENG WATERWAYS EXP STA Library, Vicksburg MS  
ARMY ENGR DIST. Library, Portland OR  
ARMY MISSILE R&D CMD Redstone Arsenal AL Sci. Info. Cen (Documents)  
ASO PWD (ENS J.A. Jenkins), Philadelphia, PA  
ASST SECRETARY OF THE NAVY Spec. Assist Energy (Leonard), Washington, DC  
CINCLANT Civil Engr. Supp. Plans. Ofc Norfolk, VA  
CINCUSNAVER Fleet Civil Engr., London UK  
CNET SCE Pensacola, FL  
CNM Code MAT-08T3, Washington, DC; MAT 044 (D Quagharello) Washington, DC  
CNO Code NOP-964, Washington DC; Code OP 323, Washington DC; Code OP 987 Washington DC; Code  
OP-413 Wash, DC; Code OPNAV 09B24 (H); OP987J (J. Boosman), Pentagon  
COMFLEACT, OKINAWA PWO, Kadena, Okinawa  
COMNAVMARIANAS Code N4, Guam  
COMNAVSUPFORANTARCTICA PWO  
COMOCEANSYSPAC SCE, Pearl Harbor HI  
DEFENSE CIVIL PREPAREDNESS AGENCY J.O. Buchanan, Washington DC  
DEFENSE ELEC SUP CEN PWO, Dayton OH  
DOE INEL Tech. Lib. (Reports Section), Idaho Falls, ID; Liffick, Richmond, WA  
DTIC Defense Technical Info Ctr/Alexandria, VA  
DTNSRDC Code 522 (Library), Annapolis MD  
DTNSRDC PWO  
ENVIRONMENTAL PROTECTION AGENCY A-104 (LCDR J.M. Stevens) Wash, DC; Reg. III Library,  
Philadelphia PA; Reg. VIII, 8M-ASL, Denver CO  
FLTCOMBATTRACENLANT PWO, Virginia Bch VA  
IBERLANTAREA Code C-4, Lisbon PO  
MARCORPS AIR/GND COMBAT CTR PWO, Twentynine Palms CA  
MARINE CORPS BASE Code 43-260, Camp Lejeune NC; PWO Camp Lejeune NC; PWO, Camp Pendleton  
CA; PWO, Camp S. D. Butler, Kawasaki Japan  
MARINE CORPS HQS Code LFF-2, Washington DC  
MARINE CORPS LOGISTICS SUPPORT ACT. PWO, Albany GA  
MCAS Facil. Engr. Div. Cherry Point NC; (Bergstrom), Code IJF, El Toro, Santa Ana, CA; CO, Kaneohe Bay  
HI; Code PWE, Kaneohe Bay HI; Code S4, Quantico VA; PWO Kaneohe Bay HI; PWO, Iwakuni Japan;  
PWO, Yuma AZ; SCE, Futema Japan  
MCDEC NSAP REP. Quantico VA  
MCLSBPAC PWO, Barstow CA  
MCRD PWO, San Diego Ca

FT19 SCE San Diego, CA  
 NAF PWD - Engr Div, Atsugi, Japan; PWO Sigonella Sicily; PWO, Atsugi Japan; PWO, Mount Clemens MI  
 NALF OINC, San Diego, CA  
 NARF Code 612, Jax, FL  
 NAS CO, Guantanamo Bay Cuba; Code 114, Alameda CA; Code 183 (Fac. Plan BR MGR); Code 187,  
 Jacksonville FL; Code 18700, Brunswick ME; Code 18U (ENS P.J. Hickey), Corpus Christi TX; Code 6234  
 (G. Trask), Point Mugu CA; Code 70, Atlanta, Marietta GA; Code 8E, Patuxent Riv., MD; Dir. Util. Div.,  
 Bermuda; ENS Buchholz, Pensacola, FL; Engr Div Dir, Meridian MS; Lakehurst, NJ; Lead. Chief, Petty  
 Offr. PW/Self Help Div, Beeville TX; PW (J. Maguire), Corpus Christi TX; PWD Maint. Cont. Dir., Fallon  
 NV; PWD, Maintenance Control Dir., Bermuda; PWD, Willow Grove PA; PWO Belle Chasse, LA; PWO  
 Chase Field Beeville, TX; PWO Jacksonville, FL; PWO Key West FL; PWO Patuxent River MD; PWO  
 Point Mugu, CA; PWO Whidbey Is, Oak Harbor WA; PWO Whiting Fld, Milton FL; PWO, Cecil Field FL;  
 PWO, Cubi Point, R.P.; PWO, Dallas TX; PWO, Glenview IL; PWO, Kingsville TX; PWO, Lemoore, CA;  
 PWO, Millington TN; PWO, Miramar, San Diego CA; PWO, Oceana, Virginia Bch VA; PWO., Moffett  
 Field CA; SCE Lant Fleet Norfolk, VA; SCE Norfolk, VA; SCE, Barbers Point HI  
 NATL RESEARCH COUNCIL Naval Studies Board, Washington DC  
 NAVACT PWO, London UK  
 NAVACTDET PWO, Holy Lock UK  
 NAVAEROSPREGMEDCEN Pub Wks Dept (Dillinger) Pensacola, FL; SCE, Pensacola FL  
 NAVAIRDEVCCEN PWO Warminster, PA  
 NAVCOASTSYSTCTR CO, Panama City FL; Code 423 (D. Good), Panama City FL; PWO Panama City, FL  
 NAVCOMMAREAMSTRSTA PWO, Norfolk VA; PWO, Wahiawa HI; SCE Unit 1 Naples Italy  
 NAVCOMMSTA Code 401 Nea Makri, Greece; Library, Diego Garcia Island; PWO, Exmouth, Australia;  
 PWO, Fort Amador Canal Zone; SCE Keflavik, Iceland; SCE Rota Spain  
 NAVCOMMU PW Dept, Thurso, Scotland  
 NAVDET PWO, Souda Bay Crete  
 NAVEDTRAPRODEVCCEN Tech. Library  
 NAVEDUTRACEN Engr Dept (Code 42) Newport, RI; PWO Newport RI  
 NAVFAC PWO Eleuthera BF; PWO Pacific Beach WA; PWO, Antigua; PWO, Brawdy Wales UK; PWO, Cape  
 Hatteras, Buxton NC; PWO, Centerville Bch, Ferndale CA; PWO, Coos Head, Charleston OR; PWO,  
 Guam  
 NAVFAC PWO, Lewes DE  
 NAVFAC PWO, Point Sur, Big Sur CA  
 NAVFACENGCOM Code 03 Alexandria, VA; Code 041 Alexandria, VA; Code 043 Alexandria, VA; Code 044  
 Alexandria, VA; Code 0451 Alexandria, VA; Code 0454B Alexandria, VA; Code 046: Code 0461D (V M  
 Spaulding) Alexandria, VA; Code 04B3 Alexandria, VA; Code 04B5 Alexandria, VA; Code 081B  
 Alexandria, VA; Code 100 Alexandria, VA; Code 1023 (T. D. Stevens), Alexandria VA; Code 1113 (M.  
 Carr) Alexandria, VA; ROICC Code 495 Portsmouth VA  
 NAVFACENGCOM - CHES DIV. Code 101 Wash, DC; Code 102, (Wildman), Wash, DC; Code 403 (H.  
 DeVoe) Wash, DC; Code 406 (Meyer) Washington, DC  
 NAVFACENGCOM - LANT DIV. CDR E. Peltier; Code 10A, Norfolk VA; Code 111, Norfolk, VA; Director  
 P.R.; Eur. BR Deputy Dir, Naples Italy; RDT&ELO 102, Norfolk VA  
 NAVFACENGCOM - NORTH DIV. Asst. Dir., Great Lakes IL; CO; Code 09P (LCDR A.J. Stewart); Code  
 1028, RDT&ELO, Philadelphia PA; Code 111 (Castranovo) Philadelphia, PA; Code 114 (A. Rhoads);  
 Design Div. (R. Masino), Philadelphia PA  
 NAVFACENGCOM - PAC DIV. (Kyi) Code 101, Pearl Harbor, HI; Code 402, RDT&E, Pearl Harbor HI;  
 Commander, Pearl Harbor, HI  
 NAVFACENGCOM - SOUTH DIV. Code 90, RDT&ELO, Charleston SC  
 NAVFACENGCOM - WEST DIV. 102; 112; Code 04B San Bruno, CA; O9P/20 San Bruno, CA; RDT&ELO  
 Code 2011 San Bruno, CA  
 NAVFACENGCOM CONTRACT Engr. Div. (F. Hein), Madrid, Spain  
 NAVHOSP PWO, Beaufort SC  
 NAVMAG SCE, Guam  
 NAVMEDRSCHU 3 PWO, Cairo U.A.R  
 NAVOCEANSYSCEN Code 41, San Diego, CA; Code 6700, San Diego, CA; Code 811 San Diego, CA; Tech.  
 Library, Code 447  
 NAVORDMISTESTFAC PWO, White Sands Missile Range NM  
 NAVORDSTA PWO, Indianhead, MD

NAVPETOFF Code 30, Alexandria VA  
 NAVPETRES Director, Washington DC; Tupman CA  
 NAVPGSCOL PWO Monterey CA  
 NAVPHIBASE CO, ACB 2 Norfolk, VA; Code S3T, Norfolk VA; PWO Norfolk, VA; UDT 21, Little Creek, VA  
 NAVRADRECFAC PWO, Kami Seya Japan  
 NAVREGMEDCEN Gen. Engr-Maint. Control, Portsmouth VA; PWO Newport RI; PWO Okinawa; PWO, Camp Lejeune NC; SCE San Diego, CA; SCE Yokosuka JA; SCE, Camp Pendleton CA; SCE, Guam; SCE, Oakland CA  
 NAVSCOLCECOFF C35 Port Hueneme, CA; CO, Code C44A Port Hueneme, CA  
 NAVSCSOL PWO, Athens GA  
 NAVSEASYSKOM Code SEA 047 Washington, DC  
 NAVSEC Code 6034 (Library), Washington DC; Code 6159D (R Bost) Washington, DC  
 NAVSECGRUACT PWO Winter Harbor ME; PWO, Adak AK; PWO, Edzell Scotland; PWO, Homestead, FL; PWO, Puerto Rico; PWO, Skaggs Is, Sonoma CA; PWO, Torri Sta, Okinawa  
 NAVSECSTA PWO, Washington DC  
 NAVSHIPREFAC Library, Guam  
 NAVSHIPYD Code 202.3, Charleston SC; Code 202.4, Long Beach CA; Code 202.5 (Library) Puget Sound, Bremerton WA; Code 380, (Woodroff) Norfolk, Portsmouth, VA; Code 400, Puget Sound; Code 400.03 Long Beach, CA; Code 404 (LT J. Riccio), Norfolk, Portsmouth VA; Code 410, Mare Is., Vallejo CA; Code 440 Portsmouth NH; Code 440, Norfolk; Code 440, Puget Sound, Bremerton WA; Code 450, Charleston SC; Code 453 (Util. Supr), Vallejo CA; L.D. Vivian; Library, Portsmouth NH; PWD (Code 400), Philadelphia PA; PWO Long Beach; PWO, Mare Is.; PWO, Norfolk; PWO, Puget Sound; SCE, Pearl Harbor HI; Utilities & Energy Cons. Mgr Code 108.1, Pearl Harbor, HI  
 NAVSTA CO Naval Station, Mayport FL; CO Roosevelt Roads P.R. Puerto Rico; Dir Mech Engr, Gtmo; Engr. Dir., Rota Spain; Long Beach, CA; PWD, Utilities Div., Guantanamo Bay Cuba; PWO Midway Island; PWO, Argentia Newfoundland; PWO, Guantanamo Bay Cuba; PWO, Keflavik Iceland; PWO, Mayport FL; SCE, Guam; SCE, San Diego CA; SCE, Subic Bay, R.P.; Utilities Engr Off. (A.S. Ritchie), Rota Spain  
 NAVSUBASE ENS S. Dove, Groton, CT; PWO Bangor, Bremerton, WA; SCE, Pearl Harbor HI  
 NAVSUPPACT CO, Seattle WA; Code 4, 12 Marine Corps Dist, Treasure Is., San Francisco CA; Code 413, Seattle WA; PWO, Brooklyn NY; PWO, New Orleans LA; Plan/Engr Div., Naples Italy; SCE, Long Beach CA; SCE, Mare Is., Vallejo CA  
 NAVSUPPFAC PWO, Thurmont MD  
 NAVSUPSYSCOM Code 324A (D Anderson) Washington, DC  
 NAVSURFWPCEN PWO, Dahlgren VA; PWO, White Oak, Silver Spring, MD  
 NAVTECHTRACEN SCE, Pensacola FL  
 NAVUSEAWARENGSTA Keyport, WA; PWO, Keyport WA  
 NAVWARCOL Dir. of Facil., Newport RI  
 NAVWPNCEN Code 2636 (W. Bonner), China Lake CA; PWO (Code 26), China Lake CA  
 NAVWPNSTA (Clebak) Colts Neck, NJ; Code 092, Colts Neck NJ; Maint. Control Dir., Yorktown VA  
 NAVWPNSTA PW Office (Code 09C1) Yorktown, VA  
 NAVWPNSTA PWO, Seal Beach CA  
 NAVWPNSTA-ST JULIENS ANNEX Asst PWO., Portsmouth, VA  
 NAVWPNSUPPCEN Code 095, Crane IN  
 NCBU 405 OIC, San Diego, CA  
 NCBC Code 10 Davisville, RI; Code 25111 Port Hueneme, CA; Code 400, Gulfport MS; NESO - Code 2522 (C Yee) Port Hueneme, CA; NESO - Code 2522 (S Ehret) Port Hueneme, CA; NESO Code 251 P.R. Winter Port Hueneme, CA; PWO (Code 80) Port Hueneme, CA; PWO, Davisville RI  
 NCBU 416 OIC, Alameda CA  
 NCR 20, Code R31 Gulfport, MS  
 NCSO BAHRAIN Security Offr, Bahrain  
 NMCB FIVE, Operations Dept; Forty, CO; THREE, Operations Off.  
 NOAA Library Rockville, MD  
 NRL PWO, Washington DC  
 NSD SCE, Subic Bay, R.P.  
 NTC Commander Orlando, FL; OICC, CBU-401, Great Lakes IL; PWO (Code 523) Orlando, FL

NUSC PWO AUTECH West Palm Bch Det. West Palm Beach, FL; PWO Newport, RI; SCE AUTECH Andros Ranges Det.  
 OFFICE SECRETARY OF DEFENSE OASD (MRA&L) Dir. of Energy, Pentagon, Washington, DC; OASD (MRA&L) Pentagon (T. Casberg), Washington, DC  
 ONR BROFF, CO Boston MA; Code 481, Arlington VA; Code 481, Bay St. Louis, MS; Dr. A. Laufer, Pasadena CA  
 PACMISRANFAC PWO, Hawaiian Area, Barking Sands, Kekaha HI  
 PMTC Code 4253-3, Point Mugu, CA  
 PWC (Lt E.S. Agonoy) Pensacola, FL; ACE Office (LTJG St. Germain) Norfolk VA; CO Norfolk, VA; CO Yokosuka, Japan; CO, (Code 10), Oakland, CA; CO, Great Lakes IL; Code 10, Great Lakes, IL; Code 110, Oakland, CA; Code 120, Oakland CA; Code 120C, (Library) San Diego, CA; Code 154, Great Lakes, IL; Code 200, Great Lakes IL; Code 220 Oakland, CA; Code 220.1, Norfolk VA; Code 30C, San Diego, CA; Code 400, Oakland, CA; Code 600, Great Lakes, IL; Code 601, Oakland, CA; Code 610, San Diego Ca; LTJG J.L. McClaine, Yokosuka, Japan; Utilities Officer, Guam; XO (Code 20) Oakland, CA  
 SPPC PWO (Code 120) Mechanicsburg PA  
 SUPANX PWO, Williamsburg VA  
 TRIREFFAC SCE Bremerton, WA  
 NAF PWO (Code 30) El Centro, CA  
 U.S. MERCHANT MARINE ACADEMY Kings Point, NY (Reprint Custodian)  
 US ARMY FORCES (S LAM) Fac Engrng Act, Korea Seoul, Korea  
 US FORCES, JAPAN Petroleum Staff Officer Yokota AB  
 USAF Jack S. Spencer, Washington, DC  
 USAF REGIONAL HOSPITAL Fairchild AFB, WA  
 USCG (G-ECV) Washington Dc; (Smith), Washington, DC; G/E (TP-62) (RADM Thompson) Washington, DC  
 USCG ACADEMY Utilities Section New London, CT  
 USCG R&D CENTER CO Groton, CT; Tech. Dir. Groton, CT  
 USDA Forest Products Lab, Madison WI; Forest Service, Bowers, Atlanta, GA; Forest Service, San Dimas, CA  
 USNA Ch. Mech. Engr. Dept Annapolis MD; Energy-Environ Study Grp, Annapolis, MD; Engr. Div. (C. Wu) Annapolis MD; Environ. Prot. R&D Prog. (J. Williams), Annapolis MD; PWD Engr. Div. (C. Bradford) Annapolis MD  
 ARIZONA State Energy Programs Off., Phoenix AZ  
 CALIFORNIA INSTITUTE OF TECHNOLOGY Pasadena CA (Keck Ref. Rm)  
 CORNELL UNIVERSITY Ithaca NY (Serials Dept, Engr Lib.)  
 FUEL & ENERGY OFFICE CHARLESTON, WV  
 INDIANA ENERGY OFFICE Energy Group, Indianapolis, IN  
 KEENE STATE COLLEGE Keene NH (Cunningham)  
 LEHIGH UNIVERSITY Bethlehem PA (Linderman Lib. No.30, Flecksteiner)  
 LIBRARY OF CONGRESS WASHINGTON, DC (SCIENCES & TECH DIV)  
 LOUISIANA DIV NATURAL RESOURCES & ENERGY Dept. of Conservation, Baton Rouge LA  
 MAINE OFFICE OF ENERGY RESOURCES Augusta, ME  
 MISSOURI ENERGY AGENCY Jefferson City MO  
 MIT Cambridge MA (Rm 10-500, Tech. Reports, Engr. Lib.)  
 MONTANA ENERGY OFFICE Anderson, Helena, MT  
 NEW HAMPSHIRE Concord, NH, (Governor's Council On Energy)  
 NY CITY COMMUNITY COLLEGE BROOKLYN, NY (LIBRARY)  
 NYS EMERGENCY FUEL OFFICE Albany NY (Butler)  
 NYS ENERGY OFFICE Library, Albany NY  
 PENNSYLVANIA STATE UNIVERSITY State College PA (Applied Rsch Lab)  
 PURDUE UNIVERSITY Lafayette, IN (CE Engr. Lib)  
 CONNECTICUT Hartford CT (Dept of Plan. & Energy Policy)  
 SOUTH DAKOTA ENERGY Pierre, SD (Off Of Energy Policy)  
 SOUTHWEST RSCH INST R. DeHart, San Antonio TX  
 UNIVERSITY OF CALIFORNIA Energy Engineer, Davis CA  
 UNIVERSITY OF HAWAII HONOLULU, HI (SCIENCE AND TECH. DIV.)  
 UNIVERSITY OF ILLINOIS URBANA, IL (LIBRARY)  
 BRITISH EMBASSY Sci. & Tech. Dept. (J. McAuley), Washington DC  
 HONEYWELL, INC. Minneapolis MN (Residential Engr Lib.)  
 NEWPORT NEWS SHIPBLDG & DRYDOCK CO. Newport News VA (Tech. Lib.)

SWEDEN VBB (Library), Stockholm  
UNITED TECHNOLOGIES Windsor Locks CT (Hamilton Std Div., Library)  
WESTINGHOUSE ELECTRIC CORP. Library, Pittsburgh PA  
WM CLAPP LABS - BATTELLE DUXBURY, MA (LIBRARY)