



Volume Mode Traveling Wave Tube Amplifier

**Richard Temkin
MASSACHUSETTS INSTITUTE OF TECHNOLOGY**

**07/08/2020
Final Report**

DISTRIBUTION A: Distribution approved for public release.

**Air Force Research Laboratory
AF Office Of Scientific Research (AFOSR)/ RTB1
Arlington, Virginia 22203
Air Force Materiel Command**

DISTRIBUTION A: Distribution approved for public release.

REPORT DOCUMENTATION PAGE		<i>Form Approved</i> OMB No. 0704-0188
<p>The public reporting burden for this collection of information is estimated to average 1 hour per response, including the time for reviewing instructions, searching existing data sources, gathering and maintaining the data needed, and completing and reviewing the collection of information. Send comments regarding this burden estimate or any other aspect of this collection of information, including suggestions for reducing the burden, to Department of Defense, Executive Services, Directorate (0704-0188). Respondents should be aware that notwithstanding any other provision of law, no person shall be subject to any penalty for failing to comply with a collection of information if it does not display a currently valid OMB control number.</p> <p>PLEASE DO NOT RETURN YOUR FORM TO THE ABOVE ORGANIZATION.</p>		
1. REPORT DATE (DD-MM-YYYY) 17-07-2020	2. REPORT TYPE Final Performance	3. DATES COVERED (From - To) 15 Apr 2015 to 14 Apr 2020
4. TITLE AND SUBTITLE Volume Mode Traveling Wave Tube Amplifier	5a. CONTRACT NUMBER	
	5b. GRANT NUMBER FA9550-15-1-0058	
	5c. PROGRAM ELEMENT NUMBER 61102F	
6. AUTHOR(S) Richard Temkin	5d. PROJECT NUMBER	
	5e. TASK NUMBER	
	5f. WORK UNIT NUMBER	
7. PERFORMING ORGANIZATION NAME(S) AND ADDRESS(ES) MASSACHUSETTS INSTITUTE OF TECHNOLOGY 77 MASSACHUSETTS AVE CAMBRIDGE, MA 02139-4301 US		8. PERFORMING ORGANIZATION REPORT NUMBER
9. SPONSORING/MONITORING AGENCY NAME(S) AND ADDRESS(ES) AF Office of Scientific Research 875 N. Randolph St. Room 3112 Arlington, VA 22203		10. SPONSOR/MONITOR'S ACRONYM(S) AFRL/AFOSR RTB1
		11. SPONSOR/MONITOR'S REPORT NUMBER(S) AFRL-AFOSR-VA-TR-2020-0103
12. DISTRIBUTION/AVAILABILITY STATEMENT A DISTRIBUTION UNLIMITED: PB Public Release		
13. SUPPLEMENTARY NOTES		
14. ABSTRACT This is the final report for the research program 'Volume Mode Traveling Wave Tube Amplifier.' High power sources of coherent radiation, producing Watts to tens of Watts of average power, are needed for applications in the millimeter wave and THz regimes. Overmoded traveling wave tubes offer the possibility of meeting these requirements in rugged and simple to fabricate devices. Three novel designs of W-band and 250 GHz TWTs have been developed at the Plasma Science and Fusion Center at MIT. The novel designs incorporate high-order mode operation and photonic band gap lattices to provide large diameter beam tunnels, compared to traditional designs. These designs were based on a previous major success with an overmoded W-Band coupled cavity traveling wave tube. The research accomplished included a detailed design of the volume mode traveling wave tube, outlined in the work of Hummelt et al. and Rosenzweig et al. These are described in the report and in publications. In addition, this program funded efforts, initiated in an earlier AFOSR program, on the interaction of high power microwaves with gases, as described in the papers by Schaub et al. and Stephens et al. A dedicated laboratory was established for testing W-Band and 250 GHz vacuum electron devices, such as TWTs, klystrons, etc. As a benchmark case for operation at 250 GHz, a backward wave oscillator (BWO) was built using a split block assembly method. The structure was assembled and found to have good low loss coupling at 250 GHz as measured with a vector network analyzer. The BWO was tested at full voltage and current in microsecond pulsed operation. As of the writing of this report, the BWO did not achieve measurable output power. The BWO will undergo further testing at a future date.		
15. SUBJECT TERMS TWT, Vacuum Electronics, Plasma Physics, Travelling Wave Tube, Electron Beam, Amplifier, HPM, HPEM, Microwave		

Standard Form 298 (Rev. 8/98)
Prescribed by ANSI Std. Z39.18

DISTRIBUTION A: Distribution approved for public release.

16. SECURITY CLASSIFICATION OF:			17. LIMITATION OF ABSTRACT UU	18. NUMBER OF PAGES	19a. NAME OF RESPONSIBLE PERSON MOSES, JULIE
a. REPORT Unclassified	b. ABSTRACT Unclassified	c. THIS PAGE Unclassified			19b. TELEPHONE NUMBER <i>(Include area code)</i> 703-696-9586

Final Report

Volume Mode Traveling Wave Tube Amplifier

AFOSR Grant FA9550-15-1-0058

Award dates: 15/04/2015 - 14/04/2020

MIT OSP 6931796

Submitted by:

Richard Temkin

Plasma Science and Fusion Center

Massachusetts Institute of Technology NW16-186

77 Massachusetts Avenue

Cambridge MA 02139

Tel. 617-253-5528

Email: temkin@mit.edu

Sponsor:

AFOSR - Air Force Office of Scientific research

875 N. Randolph Street. Rm 4-088

Arlington, VA 22203

Attn.: Dr. William P. Roach

ROACH, WILLIAM P DR-04 USAF AFMC AFOSR/RTB

<william.roach.4@us.af.mil>

Date: July 8, 2020

Abstract

High power sources of coherent radiation, producing Watts to tens of Watts of average power, are needed for applications in the millimeter wave and THz regimes. Overmoded traveling wave tubes offer the possibility of meeting these requirements in rugged and simple to fabricate devices. Three novel designs of W-band and 250 GHz TWTs have been developed at the Plasma Science and Fusion Center at MIT. A dedicated laboratory was established for testing W-Band and 250 GHz vacuum electron devices. The novel designs incorporate high-order mode operation and photonic band gap lattices to provide large diameter beam tunnels, compared to traditional designs. These designs were based on a previous major success with an overmoded W-Band coupled cavity traveling wave tube.

Report Outline

This is the final report for the research program “Volume Mode Traveling Wave Tube Amplifier.” The research accomplished included a detailed design of the volume mode traveling wave tube, outlined in the work of Hummelt et al. and Rosenzweig et al. These are described in the following pages and in the publications. In addition, this program funded our efforts, initiated in an earlier AFOSR program, on the interaction of high power microwaves with gases, as described in the papers by Schaub et al. and Stephens et al.

A dedicated laboratory was established for testing W-Band and 250 GHz vacuum electron devices. As a benchmark case for operation at 250 GHz, a backward wave oscillator (BWO) was built using a split block assembly method. The structure was assembled and found to have good low loss coupling at 250 GHz as measured with a vector network analyzer. The BWO was tested at full voltage and current in microsecond pulsed operation. As of the writing of this report, the BWO did not achieve measurable output power. The BWO will undergo further testing at a future date.

These advances are described in the following pages.

Publications

1. "Overmoded Traveling Wave Tubes for MM and THz Applications," by Jason S. Hummelt, Sudheer Jawla, Elizabeth J. Kowalski, Michael A Shapiro and Richard J. Temkin 2015 40th International Conference on Infrared, Millimeter, and Terahertz waves (IRMMW-THz) 23-28 Aug. 2015 Hong Kong, China (2015).
2. "Electron Density and Gas Density Measurements in a Millimeter-Wave Discharge," S. C. Schaub, J. S. Hummelt, W. C. Guss, M. A. Shapiro, and R. J. Temkin Phys. of Plasmas, Vol. 23, 083512 (2016).
3. "Designs of W-band TWT amplifiers with large beam tunnels," Guy Rosenzweig; Jason S. Hummelt; Michael A. Shapiro; Richard J. Temkin 2016 IEEE International Vacuum Electronics Conference (IVEC) 19-21 April 2016 Monterey, CA, USA (2016).
4. "A multi-term Boltzmann equation benchmark of electron-argon cross-sections for use in low temperature plasma models," Jacob Stephens J. Phys. D:Appl. Phys, 51 125203 (2018).
5. "Design of a 250 GHz disk-loaded waveguide TWT amplifier," Guy Rosenzweig, Michael A. Shapiro, and Richard J. Temkin, 2018 IEEE International Vacuum Electronics Conference (IVEC) 24-26 April 2018 Monterey, CA, USA (2018).
6. "Oversized 250 GHz Traveling Wave Tube with a Photonic Band-Gap Structure," Guy Rosenzweig, Michael A Shapiro, Richard J Temkin, APS Division of Plasma Physics Meeting 2017, abstract id. TO8.002 October 2017.
7. "Design of Oversized TWTs With Photonic Band-Gap Structures" Guy Rosenzweig, Jacob C Stephens, Michael A Shapiro, Richard J Temkin 2017 IEEE International Conference on Plasma Science (ICOPS) (2017).

Overmoded Traveling Wave Tubes for MM and THz Applications

High power sources of coherent radiation, producing Watts to tens of Watts of average power, are needed for applications in the millimeter wave and THz regimes. Overmoded traveling wave tubes offer the possibility of meeting these requirements in rugged and simple to fabricate devices. Results on a 94 GHz overmoded TWT confirm the viability of this approach. Designs for a PBG amplifier operating at 250 GHz, based on the successful 94 GHz TWT, are described.

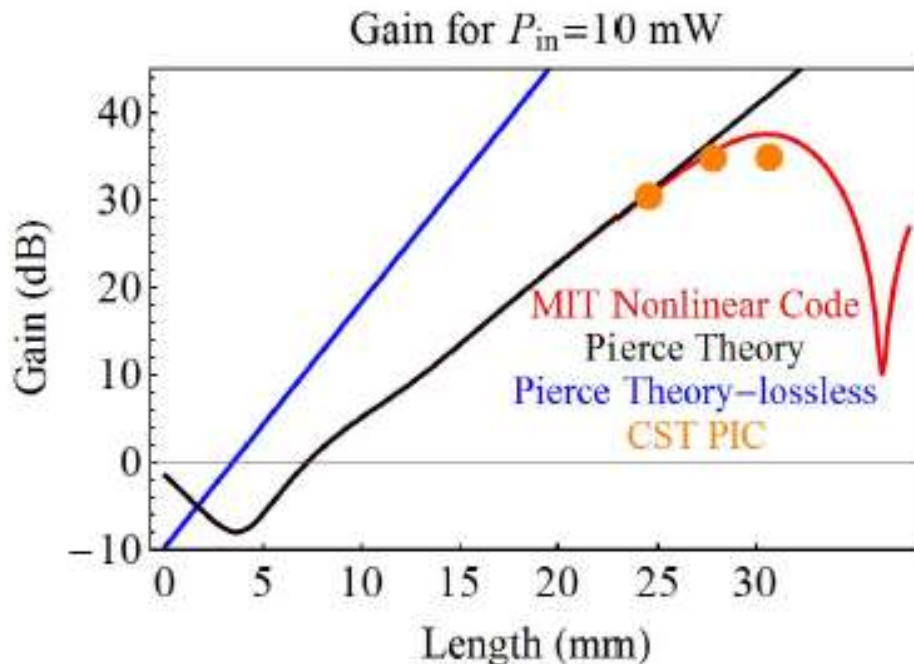

Figure Gain curves vs. Length for the PBG TWT amplifier operating at 20 kV, 200 mA. Shown is the gain using lossless Pierce theory (blue), Pierce theory with ohmic loss and space charge (black), the nonlinear MIT code (red), and CST PIC simulations (orange dots) for $f=250.6$ GHz.

Further details are available in . “Overmoded Traveling Wave Tubes for MM and THz Applications,” by Jason S. Hummelt, Sudheer Jawla, Elizabeth J. Kowalski, Michael A Shapiro and Richard J. Temkin 2015 40th International Conference on Infrared, Millimeter, and Terahertz waves (IRMMW-THz) 23-28 Aug. 2015 Hong Kong, China (2015).

W-band TWT amplifiers with large beam tunnels

Three novel designs of W-band TWTs have been developed at the Plasma Science and Fusion Center at MIT. These designs incorporate high-order mode operation, and photonic band gap lattices to provide large diameter beam tunnels, compared to traditional designs. The first successful overmoded TWT was already built and tested, and a second design is underway.

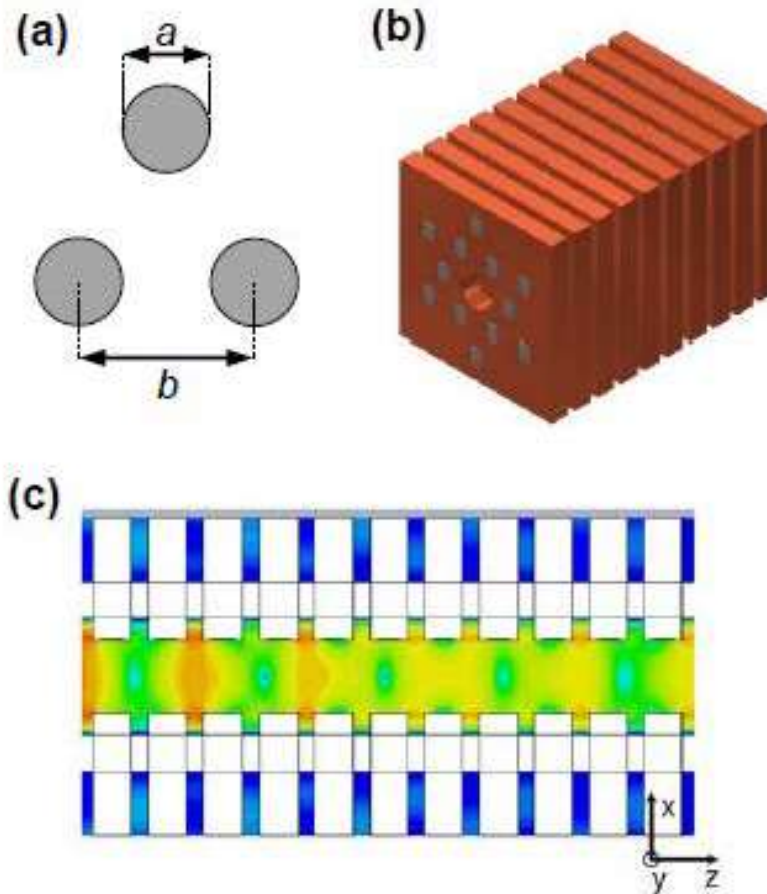

Figure. (a) Unit cell of the PBG lattice (b) One period of the PBG based TWT; (c) Top view of CST MWS electric field simulation of a 75-period PBG (of which 11 are shown).

Further details are in “Designs of W-band TWT amplifiers with large beam tunnels,” Guy Rosenzweig; Jason S. Hummelt; Michael A. Shapiro; Richard J. Temkin 2016 IEEE International Vacuum Electronics Conference (IVEC) 19-21 April 2016 Monterey, CA, USA (2016).

Oversized 250 GHz Traveling Wave Tube with a Photonic Band-Gap Structure

The challenge in manufacturing traveling wave tubes (TWTs) at high frequencies is that the sizes of the structures scale with, and are much smaller than, the wavelength. We have designed and are building a 250 GHz TWT that uses an oversized structure to overcome fabrication and power handling issues that result from the small dimensions. Using a photonic band-gap (PBG) structure, we succeeded to design the TWT with a beam tunnel diameter of 0.72 mm. The circuit consists of metal plates with the beam tunnel drilled down their center. Twelve posts are protruding on one side of each plate in a triangular array and corresponding sockets are drilled on the other side. The posts of each plate are inserted into the sockets of an adjacent plate, forming a PBG lattice. The vacuum spacing between adjacent plates forms the "PBG cavity". The full structure is a series of PBG coupled cavities, with microwave power coupling through the beam tunnel. The PBG lattice provides confinement of microwave power in each of the cavities and can be tuned to give the right amount of diffraction per cavity so that no sever is needed to suppress oscillations in the operating mode. CST PIC simulations predict over 38 dB gain with 67 W peak power, using a 30 kV, 310 mA electron beam, 0.6 mm in diameter.

Design of a 250 GHz disk-loaded waveguide TWT amplifier

A mm-wave disk-loaded waveguide (DLWG) traveling wave tube (TWT) amplifier is being designed for operation at 250 GHz. This design, in which coupling from cell to cell is via a highly oversized beam tunnel, is attractive due to the ease in fabrication, even at high frequencies. The design has been conducted using analytic Pierce theory and time-domain simulations, which predict high gain. However, particle-in-cell (PIC) simulations show hybrid modes that de-bunch the electron beam and deteriorate the device performance when the structure length is increased to achieve very high gain. Additional design optimization is needed to avoid these unwanted modes.

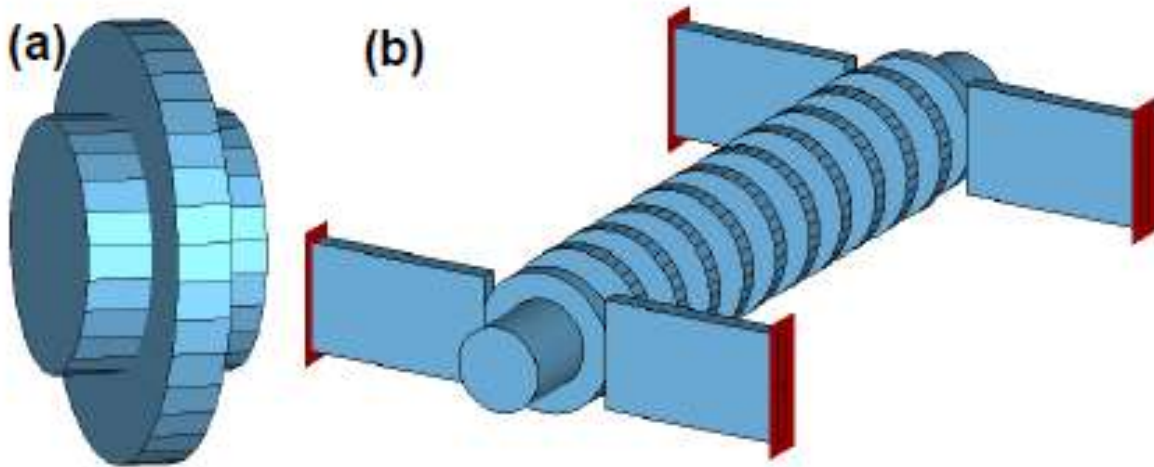

Figure. (a) Unit cell (single period) of the 250 GHz DLWG TWT, and (b) a structure with 10 cells and input and output couplers. Shown here is the vacuum region of the device

Further details are presented in "Design of a 250 GHz disk-loaded waveguide TWT amplifier," Guy Rosenzweig, Michael A. Shapiro, and Richard J. Temkin, 2018 IEEE International Vacuum Electronics Conference (IVEC) 24-26 April 2018 Monterey, CA, USA (2018).

Electron Density and Gas Density Measurements in a Millimeter-Wave Discharge

Electron density and neutral gas density have been measured in a non-equilibrium air breakdown plasma using optical emission spectroscopy and two-dimensional laser interferometry, respectively. A plasma was created with a focused high frequency microwave beam in air. Experiments were run with 110 GHz and 124.5 GHz microwaves at powers up to 1.2MW. Microwave pulses were 3 μ s long at 110 GHz and 2.2 μ s long at 124.5 GHz. Electron density was measured over a pressure range of 25 to 700 Torr as the input microwave power was varied. Electron density was found to be close to the critical density, where the collisional plasma frequency is equal to the microwave frequency, over the pressure range studied and to vary weakly with input power. Neutral gas density was measured over a pressure range from 150 to 750 Torr at power levels high above the threshold for initiating breakdown. The two-dimensional structure of the neutral gas density was resolved. Intense, localized heating was found to occur hundreds of nanoseconds after visible plasma formed. This heating led to neutral gas density reductions of greater than 80% where peak plasma densities occurred. Spatial structure and temporal dynamics of gas heating at atmospheric pressure were found to agree well with published numerical simulations.

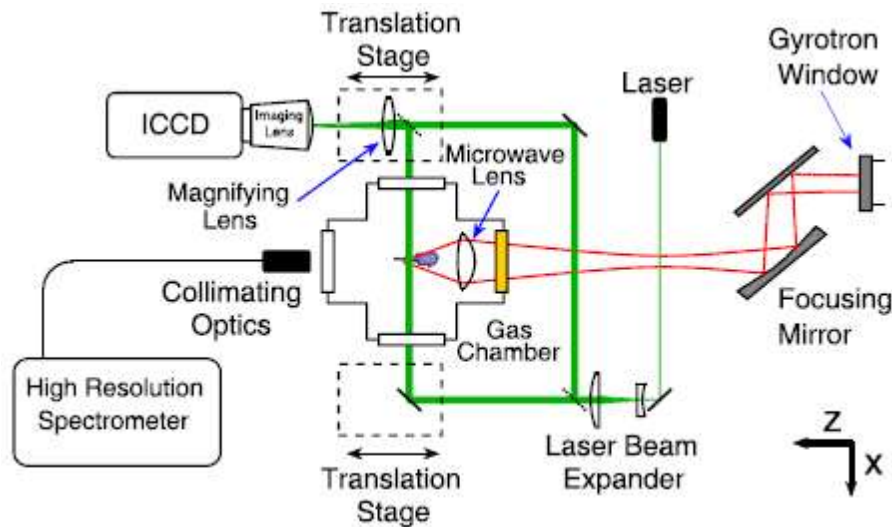

Figure Schematic of the Experimental Apparatus

Further details are presented in "Electron Density and Gas Density Measurements in a Millimeter-Wave Discharge," S. C. Schaub, J. S. Hummelt, W. C. Guss, M. A. Shapiro, and R. J. Temkin *Phys. of Plasmas*, Vol. 23, 083512 (2016).

A multi-term Boltzmann equation benchmark of electron-argon cross-sections for use in low temperature plasma models

This study details the development, validation, and utilization of a multi-term Boltzmann equation (BE) model to benchmark argon cross-section sets for their use in low temperature plasma models. First, a complete derivation of the multi-term BE model is given. The multiterm BE model is verified by comparing calculated transport coefficients to known solutions for both conservative and non-conservative model gases. A general comparison between the solutions of the multi-term BE model and the solutions of the two-term BE model, BOLSIG+ , and the Monte Carlo collision model, METHES, is also reported. The multi-term BE model is used to calculate electron swarm parameters from three independently developed argon cross-section sets, which are compared with experimental data. Swarm parameters calculated from the Biagi cross-section set feature the best agreement with experimental data, with the exception of the first Townsend coefficient, which is best reproduced using the cross-section set of Zatsarinny and Bartschat.

Further details are presented in “A multi-term Boltzmann equation benchmark of electron-argon cross-sections for use in low temperature plasma models,” Jacob Stephens *J. Phys. D:Appl. Phys.*, 51 125203 (2018).

Acknowledgments

This research was supported by the Air Force Office of Scientific Research through grant FA9550-15-1-0058.