



**A MODEL TO ANALYZE THE CAPACITY OF PILOT TRAINING  
PRODUCTION**

Graduate Research Paper

Derek J. Colbath, Major, USAF

AFIT-ENS-MS-20-J-027

**DEPARTMENT OF THE AIR FORCE  
AIR UNIVERSITY**

**AIR FORCE INSTITUTE OF TECHNOLOGY**

---

**Wright-Patterson Air Force Base, Ohio**

DISTRIBUTION STATEMENT A.  
APPROVED FOR PUBLIC RELEASE; DISTRIBUTION UNLIMITED.

The views expressed in this graduate research paper are those of the author and do not reflect the official policy or position of the United States Air Force, Department of Defense, or the United States Government. This material is declared a work of the U.S. Government and is not subject to copyright protection in the United States.

AFIT-ENS-MS-20-J-027

A MODEL TO ANALYZE THE CAPACITY OF  
PILOT TRAINING PRODUCTION

Graduate Research Paper

Presented to the Faculty

Department of Operational Sciences

Graduate School of Engineering and Management

Air Force Institute of Technology

Air University

Air Education and Training Command

In Partial Fulfillment of the Requirements for the  
Degree of Master of Science in Operations Management

Derek J. Colbath, BS, MS, Major, USAF

June 2020

DISTRIBUTION STATEMENT A.  
APPROVED FOR PUBLIC RELEASE; DISTRIBUTION UNLIMITED.

A MODEL TO ANALYZE THE CAPACITY OF PILOT TRAINING PRODUCTION

Derek J. Colbath, BS MS

Major,

USAF

Committee Membership:

Alfred E. Thal, Jr., PhD

Chair

## **Abstract**

A worldwide shortage for pilots combined with an increasing global demand for air transportation has left the United States Air Force 10% short of required pilot manning numbers. Air Education and Training Command (AETC) is working hard on the front line to increase training capacity; however, the complexity of the training process has made it difficult to smooth the flow. Review of literature on pilot production, organizational management, and queueing yielded the need to model the pilot production process to better understand the relationship between sub-programs. This model examines the variables of the training pipeline and helps determine some of the limiting factors that constrain capacity. This model maps all the sub-processes in the pilot production pipeline to understand how they relate. Applying Little's law to this production map demonstrates how current production initiatives will not solve the production problem. Increasing the throughput of one part of a process does not necessarily increase the throughput of the entire production program.

## **Dedication**

*To my family*

*This research paper would not have been possible without my wife who diligently maintains the home front. Her continuous support during multiple TDY's and class outings has eased the burden of a tough year. She has not only excelled at the roles of military spouse and mother of three, but has proven to be an outstanding teacher to two school aged girls during a tough time in the world. I am forever grateful to have you in my life.*

*My three girls have been amazing despite being cooped up in the house during COVID-19 isolation. Their cooperation while Daddy works from home, and Mommy teaches school work, speaks to their character and I'm extremely proud and thankful for each of them.*

## **Acknowledgments**

I would like to express my sincere appreciation to my faculty advisor, Dr Al Thal , for his guidance and support throughout the course of this graduate research project. The insight and experience and patience was certainly appreciated. I would, also, like to thank my sponsor, Colonel Gary Eilers, from 19th Air Force for both the support and latitude provided to me in this endeavor.

Derek J. Colbath

## Table of Contents

Acknowledgments.....	vii
Table of Figures .....	ix
<b>I. Introduction .....</b>	<b>1</b>
General Issue .....	1
Research Objectives and Questions .....	5
Methodology .....	5
Assumptions/Limitations .....	7
Implications.....	8
Historical UPT Production.....	11
Other Programs .....	12
Operational Management.....	15
Summary of Literature .....	19
<b>III. Methodology .....</b>	<b>20</b>
Mapping the process.....	21
Introductory Flight Training.....	21
Undergraduate Pilot Training.....	25
Post UPT Training.....	28
<b>IV. Analysis and Results.....</b>	<b>32</b>
Investigative Questions Answered.....	38
Summary .....	40
<b>V. Conclusions and Recommendations .....</b>	<b>42</b>
Conclusions of Research.....	42
Significance of Research.....	43
Recommendations for Future Research .....	43
Summary .....	44
<b>Appendix A.....</b>	<b>46</b>
<b>References.....</b>	<b>48</b>

## Table of Figures

Figure 1. Air Force Pilot Inventory (Callander, 2008) .....	2
Figure 2. Five Focusing Steps - Theory of Constraints (Vorne, 2020).....	6
Figure 3. Delivery Performance vs. Utilization Rate (Strategos Inc. , UNK) .....	18
Figure 4. IFT to UPT Process .....	22
Figure 5. Cycle Time and Classes per Year for IFT and UPT.....	23
Figure 6. UPT Phase I - Phase III .....	26
Figure 7. Cycle Time and Classes per Year for UPT Phase I - Phase III .....	28
Figure 8. Post Graduate Pilot Training .....	30
Figure 9. Throughput Concept.....	33
Figure 10. Pilots Awaiting Training .....	36
Figure 11. Cost per Flight Hour.....	37
Figure 12. Cost of Service vs. Cost of Waiting .....	38

# **A Model to Analyze the Capacity of Pilot Training Production**

## **I. Introduction**

*“We don’t let hope be a plan, we don’t let enthusiasm or infatuation with an idea drive behavior. We let the facts and effectiveness be our measuring stick. So the only thing I am a champion of is solving the pilot training problem permanently.”*

*- Lt General Steven L. Kwast*

### **General Issue**

The United States Air Force is facing a pilot retention crisis. Currently, the Air Force is 2,000 pilots short of its desired end state, which is approximately ten percent of its overall pilot population (Losey, 2018). Historically, pilot manning requirements have changed between administrations and total force strength mandated by Congress. Pilot manning numbers were as high as 24,000 immediately following the Cold War but drew down to 14,792 by the late 1990s (Callander, 2008). Current requirements put the number around 21,000 pilots who needed to properly fill flying Squadrons (Pawlyk, 2020). Air Education and Training Command (AETC) is responsible for training pilots for the Air Force. In the late 1980s when pilot manning requirements were similar to current requirements, AETC was able to produce 1,581 pilots per year. Figure 1 shows historical data on the Air Force’s pilot inventory as well as the production rates from 1981 to 1995.

In 2019, AETC was able to graduate 1,201 pilots. However, pilot training production continues to fall short of recovery requirements. In 2019, pilot production fell short of recovery requirements by 195 pilots, which is a 15 percent shortfall. Projected recovery planning shows the requirement for more graduates will increase in the next few years. AETC is planning to

increase Undergraduate Pilot Training (UPT) production from 1,200 pilots per year to 1,480 pilots per year by 2022.

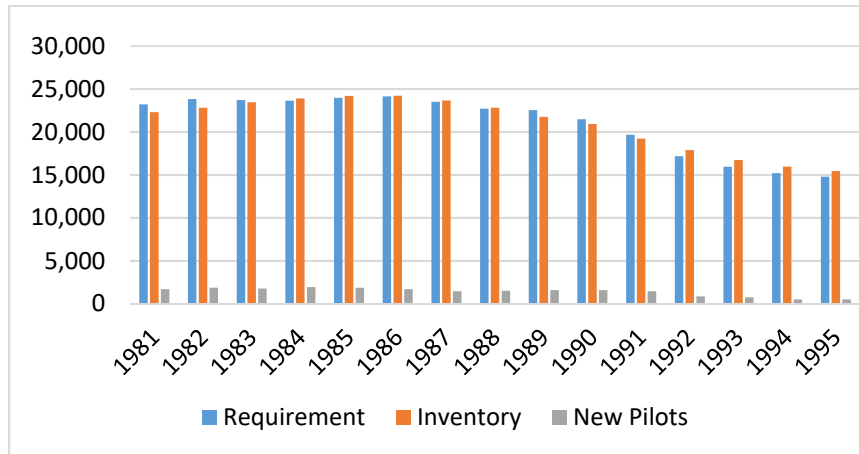

Figure 1. Air Force Pilot Inventory (Callander, 2008)

Pilot training in the Air Force has remained largely unchanged for the past 75 years. It takes roughly 18 months to train a mobility pilot and as long as 24 months to train a fighter or bomber pilot. The training program is broken up into several parts. First, students will attend Initial Flying Training (IFT) in Pueblo Colorado. The school is operated by DOSS aviation as a government contract to establish a baseline for students entering the training pipeline. Students get 15-20 hours in a DA-20 aircraft to quickly and cheaply determine if a student exhibits the traits necessary to become a pilot in the Air Force. This is typically where individuals with no prior flying experience determine if they actually want to be a pilot.

After successful completion, students will go to Undergraduate Pilot Training at one of four locations: Laughlin Air Force Base (AFB) in Del Rio, Texas; Vance AFB in Enid, Oklahoma; Columbus AFB in Columbus, Mississippi; and Sheppard AFB in Wichita Falls, Texas. UPT is broken down into three phases. Phase I is 1 month of academics and

physiological training, while Phase II is six months of academics, simulations, and flying in the T-6 aircraft. Training consists of basic flying and navigation, instrument training, advanced aerobatics, and formation flying. UPT conducted at Sheppard AFB as part of the Euro-NATO Joint Jet Pilot Training (ENJJPT) includes an additional training block in 2-ship low level navigation. Students receive 80-120 hours of flight time during this phase. After Phase II, students will typically track towards a type of Major Weapons System (MWS). This means students will either be “tracked” towards a heavy airframe (mobility pilot), a fighter/bomber platform, or a helicopter. Phase III of UPT is six months of academics, simulations, and flying in either the T-1 Jayhawk, T-38 Talon, or TH-1H Huey based off of how a student was tracked.

After successful completion of UPT, a student pilot will graduate and receive their wings. Three weeks prior to graduation, a UPT class will receive their “drop” and the student pilots find out what MWS they will be assigned to. After graduation, pilots will then proceed to one of several formal training courses located all over the country. Mobility, bomber, and helicopter pilots will proceed directly to their schoolhouse based on their MWS assignment and fighter pilots will go to Introduction to Fighter Fundamentals (IFF).

IFF is an eight-week program that teaches a young pilot the discipline and attitude it takes to be a fighter wingman. After completing IFF, fighter-assigned pilots will go on to the formal training units (B-course) for their respective airframes. B-Courses as well as Formal Training Units (FTU) are variable in length but typically take 6-7 months to complete. In this stage of training, pilots learn to operate their respective weapon systems. Once complete with the FTU or B-Course, pilots are finally assigned to a Squadron. At the squadron, there is additional training designed to teach a pilot how to employ their weapon system as well as sharpen their skills on operating the weapon system. Once complete with the additional training, a pilot is finally

considered mission ready. The additional training conducted at the squadron varies in length, largely dependent on aircraft availability, skill level, and Squadron mission demands. Each airframe type has a different term to describe this training. In the tanker world, it is called Mission Continuation Training (MCT). A simplified model can be described as follows: UPT teaches the rules and fundamentals, FTU/B-Course teaches how to operate the MWS, and MCT teaches the pilot how to employ that MWS in a fight. Start to finish, it takes two years to train a mission ready pilot under the current training model.

To span the gap in the training shortfall, AETC has attempted a few strategies in recent years to increase training capacity in their Undergraduate Pilot Training programs. Initiatives to shorten the training syllabi to eliminate redundancies have led to increasing production by a full class each year. Additionally, AETC led an initiative called UPT-Next which attempted to change the training paradigm from a batch model to a self-paced training model utilizing new simulators and augmented reality simulators to provide more access to self-paced training opportunities; this paradigm shift would have significant implications to the flow rate of a production model. UPT-Next has led to the creation of UPT-2.5 which takes many of the lessons learned from UPT-Next and uses targeted applications to shorten UPT from 12 months to 9 months.

## **Problem Statement**

Pilot production is an essential part of national defense initiatives. Defense, readiness, global reach, and power projection all stem from the Air Force's ability to train Airmen. The pilot production process is a very complex web of smaller training programs that are all intimately interrelated. Currently, there is no tool that shows the production process in its

entirety that provides decision-makers the ability to see the relationships that exist between training programs. In an effort to reduce production time and decrease inefficiencies, it is extremely important for the Air Force to consider the relationship that exists between training programs. Increasing UPT throughput is only a piece of the overall pilot production process.

### **Research Objectives and Questions**

Currently, there is no standardized way to determine or report capacity. Developing a model that can be tailored and applied to all phases of training would enable accurate reporting of capability and highlight where shortfalls really exist. Additionally, the model would help forecast where problem areas would occur if demand signals change. The purpose of this study is to map the entire pilot training production pipeline and model how to determine capacity. The initial research will show the process on a macro level but provide suggested implementation down to the micro level. This research will investigate the following questions

1. Where are the current bottlenecks in the pilot production pipeline?
2. If AETC is successful in increasing pilot production capacity to 1,480 pilots per year, will the rest of the pipeline be able to handle the extra capacity?
3. What are the financial implications of increasing UPT capacity?

### **Methodology**

Air Education and Training Command has set a goal of producing 1,480 winged pilots per year. There are several challenges that AETC faces in reaching that goal. This research will apply the Theory of Constraints, developed by Dr. Eliyahu Goldratt, to the pilot production process (Goldratt, 1984). This methodology will be utilized to identify the limiting factors

(constraints) that stand in the way of achieving AETC’s goal of 1,480 pilots per year. In his book, Goldratt (1984) describes the use of process called the “Five Focusing Steps” in an iterative manner as depicted in Figure 2. This research will focus on the first step of the Five Focusing Steps, which is to Identify the Constraint. The model developed in this research is designed to provide a framework to continually identify the constraint in a process that has literally thousands of variables.

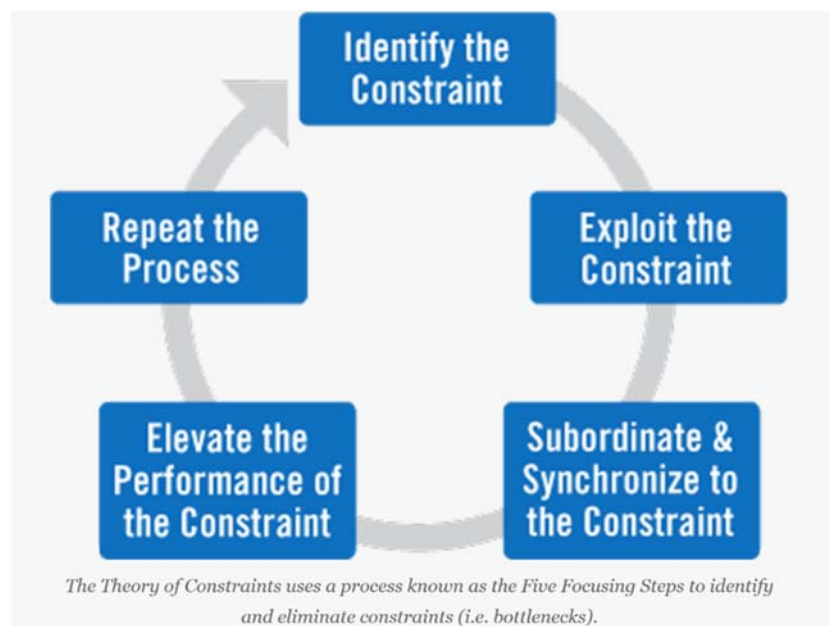

Figure 2. Five Focusing Steps - Theory of Constraints (Vorne, 2020)

The first step to a capacity analysis is to accurately map the process. Using program information, available literature, and data, this research will map the current process. The map will include key decision points and identify where inputs may vary. Each branch of the process will be mapped in its entirety. Program information will be utilized to develop a method to determine capacity and the flow rate for each of the parts of the production pipeline. Finding the capacity and flow rates will allow the researcher to determine the capacity to produce pilots for

the Air Force. The model can then be applied to specific parts of the production pipeline and drilled down to determine the capacity of a specific MWS. This analysis will allow senior leaders to determine where the bottlenecks are in the production process and allocate resources appropriately. The research will begin by taking a big picture approach to the training production program. The complexity of the model will increase as time and data permits.

After the pipeline is mapped out, the research will apply Little's law of queueing theory to show the relationship that exists between various steps in the production pipeline. The result will show how changes in the process can affect how many, and how long, students are in or awaiting training. Little's basic theorem states that the average number of customers ( $L$ ) in a system is equal to the average arrival rate of the customers ( $\lambda$ ) multiplied by the average time the customer spends in the system ( $W$ ).

$$L = \lambda W$$

Little's law, as well as several variations of it, are explained in great detail by Adan and Resing (2001). While there were several other mathematical representations that could be utilized to express queueing, Little's law was the most applicable on each level. Little's law can be utilized to express the entire system or each individual sub-system and is also applicable to the batch model of the pilot production program. Adan and Resing (2001) also derive several other variations of Little's law and describes scenarios where they can be utilized.

### **Assumptions/Limitations**

The biggest assumption with this analysis is that the capacity of each of the training units is reported correctly. For example, the number of available instructor pilots is sufficient to cover the number of students in the program in addition to fulfilling individual recurring training

events for the instructors themselves. Aircraft availability needs to be greater than or equal to student and instructor requirements. Instructor manning has to be greater than or equal to student demand. If FTU and B-Course training programs do not have the capacity to handle additional students, the number of students awaiting training will continue to grow. An analysis of the data in itself is also a limitation as it takes the human element out of the consideration. UPT is consistently referred to as a meat grinder or a hamster wheel. Many UPT instructors relate it to the movie “Groundhog Day” where the main character experiences the same day over and over again. What is not captured in the data is the extraordinary lengths that UPT and FTU instructors go through to graduate students on time. In some cases it means flying three sorties a day to include weekends. In other instances, it means waiving syllabus requirements. The stress on the system and health of the force is not accurately captured with this data. Another assumption to the data is that the level of training quality will remain constant. Quantitative analysis of the quality of training is possible utilizing data from Training Integration Management System (TIMS). It would be possible to run regression analysis on UPT data against that of FTU/B-course performance. Historically, there is a ton of data that would provide a suitable baseline for UPT performance.

## **Implications**

The implications for this analysis is to determine the factors that dictate the training capacity of the Air Force pilot training production program. Senior leaders will be able to make more informed decisions on where to place resources such as aircraft and instructors to produce pilots more efficiently for the Air Force. Additionally, this model will be able to show how an increase in student arrival rate can have drastic effects on students awaiting follow-on training.

## **Structure**

This research paper will begin with an examination of literature on the topics of pilot training, organizational management, capacity analysis, and queuing. The goal of this review of literature is to determine the following.

- 1) If there is a need to analyze the capacity of pilot training for the Air Force.
- 2) If a capacity analysis has been conducted on a training program as complex
- 3) If a method has been utilized to conduct a similar analysis.

Following the review of literature, this research will determine and explain the method in which this research has been conducted. The results of the research will be described in the analysis section followed by a summary of the research findings with recommendations for further research.

## II. Literature Review

*“You can’t train a pilot in just a year. You have to absorb them into a squadron, get them qualified in a weapons system”*

*– Former Secretary of the United States Air Force, Heather Wilson*

Pilot training production is an extensive process with a large number of variables that can be considered. There are multiple avenues to examine the process to make it more efficient. This research examined literature from several industries in an effort to utilize a best practice approach to operational management. Operational management is a very broad topic and typically centers around production efficiency. Most models developed are designed to maximize profit. However, pilot training production is less interested in the cost and more interested in the number and quality of the output. In other words, how many pilots can be produced without sacrificing quality? A quantitative analysis of pilot quality is possible but is beyond the scope of this research.

In order to understand where the pilot training program currently is, it is first necessary to understand how it has evolved. First, this research will take a look at the history of pilot training in the Air Force. Production numbers have changed over the 75-year history of the service. This research will attempt to determine causation. The next area for research will focus on other pilot training programs to determine if there are drastic differences or best practices that can be gleaned. The final area of research will focus on operational management, including capacity and production examples. The research will review industry perspectives, practices of operational management, and smooth flow production techniques. Combined, these three lines

of research will provide a framework for analyzing the pilot production process and determining production limitations.

## **Historical UPT Production**

Historical UPT production has changed as budgets and conflicts have emerged. Pilot shortages have existed in the Air Force as recently as the late 1990s as a result of poor production numbers in the early to mid-1990s. In 2008, an article was published in the Air Force magazine with historical data on pilot production numbers. The article opens by stating, “In 1943, the US Army Air Forces produced 97,792 rated officers – 65,797 pilots, 15,938 navigators and 16,057 bombardiers. Now the task would take 158 years” (Callander, 2008). Those almost impossibly high numbers in today’s standards were the result of World War II and will likely never be seen again. Sprys (2018) completed a comprehensive analysis of the history of UPT and discusses the various motivations and changes that have taken place over the past 75 years. In his analysis, he discusses the 50% attrition rates in the 1950s that prompted a change in how pilot training was conducted (Sprys, 2018). Following this analysis, the Air Force changed its training program from a one-size-fits-all approach to a specialized training program, acknowledging that not all the pilots the Air Force trains will be fighter pilots.

The Vietnam War brought on another huge demand for pilot production. The pilot production goal of 1971 was projected to be over 4,300 pilots (VanHoose, 2012). Periods defined by peace such as the Post-Cold War era leading up to Operation Desert Storm are characterized by relatively low production numbers. The low production numbers during this time frame was a growing concern for Air Force leaders and prompted several studies into pilot retention and production analysis. Many industry experts acknowledge that airline furloughs,

prompted by the attacks on 11 September 2001, prevented a massive pilot shortfall in the DoD (Hebert, 2008). The attacks caused five of the six major legacy airlines in the U.S. to declare bankruptcy, and air travel decreased to the point where airline captains were forced to vacate their position and go back to first officer (Gall, 2018). This gave the Air Force enough time to ramp up pilot production by almost 800 additional pilots per year.

The increase in production was more than double the production numbers of the mid 1990s. Despite the increase in production, AETC has been able to exceed 1,400 pilots in a year only once since 2007 (Maucione, 2019). The last time the Air Force has hit AETC's target of 1,480 students per year was 1990 (Callander, 2008). The Air Force has not been able to reach that production goal since the service changed to the Specialized UPT model in 1992 (Sprys, 2018). Future production efforts may return to the generalized UPT model with the advent of the T-7 Red Hawk and possible divestment of the T-1 Jayhawk.

## **Other Programs**

In order to improve a program, it is important to look at the entire industry to determine some of the best practices that exist. The United States Air Force is not the sole pilot production program in the country and certainly not the world. There are thousands of flight training schools scattered all over the United States. These flight training programs have widely varying degrees of reputation. Pilot training programs range from recreational programs designed for the hobbyist to commercial programs meant for federally license commercial pilots. Other branches of the Department of Defense such as the United States Navy and Army, have their own pilot production programs. On a global scale, the military from other countries have their own pilot training programs. This research will take a look at examples of other pilot training programs.

Almost all of the major U.S. airlines rely on other pilot production programs to source their pilot talent. In February 2020, United Airlines acquired the Aviate Pilot program to become the only major U.S. carrier to own a flight training academy (United Airlines, 2020). The Aviate Pilot program is a partnership of several well-known aviation schools around the country. This newly minted program is United Airlines solution to the pilot shortage. United Airlines alone is looking to hire approximately 10,000 pilots in the next 10 years and expects to lose more than half of its 12,500 pilots currently on the payroll (Josephs, 2019). United Airlines is the first major commercial airline to realize they cannot depend solely on pilots produced by the DoD and regional airlines. A full list of the Aviate Pilot partners is shown in Appendix 1.

The United States Navy (USN) also has a flight training program that closely resembles that of the United States Air Force. The differences in training are primarily the aircraft utilized and the skillsets that are learned. The phases of training follow the same type of pipeline and timeline. The USN is facing training and retention issues similar to that of the Air Force. According to Maucione (2019), “In 2018, the Navy lost 611 pilots. That is 131% higher than the 10-year average of 465.” With the commercial airline industry being heavily reliant on outside sources for pilot talent and the USN facing the same issues as the USAF, the only other place within the industry to explore is the pilot training programs of other nations.

There are many countries that have well respected air forces. The United Kingdom, Israel, France, Germany and Australia are consistently listed in the top 20 air forces in the world (airsceneuk, 2018). The pilot training program for these air forces could provide insight into how to better structure pilot training in the U.S. The Royal Air Force is facing similar struggles to that of the U.S. and has been trying to innovate the way they train pilots. According to assistant director for flying training of the RAF’s Headquarters 22 Group, “The RAF needs to

reduce the time it takes to train a pilot, as well as increase our overall pilot numbers because we have pilots leaving faster than we can produce them” (Losey, 2019). It takes a full 3 years to train an Israeli Air Force pilot and they only require a service commitment of 7 years as opposed to the 10 years required of a USAF pilot (IAF, 2018). The French have a similar style of pilot training production in that students start out on a turbo prop prior to advancing to a jet trainer. Additionally, the French Air Force tracks its pilots based on the type of aircraft they will fly for the service (DCI, 2020). Germany, as well as several other NATO countries, rely on the Euro-NATO Joint Jet Pilot Training (ENJJPT) program for pilot production. ENJJPT is an international program hosted in the United States at Sheppard AFB. Some aspects of the German Luftwaffe training program are organic to Germany but their fighter pilot production relies completely on the ENJJPT program. Due to the fact that some NATO countries rely completely on the ENJJPT program, combined with the demand for pilots globally, ENJJPT is facing capacity issues. Since the United States is a partner nation in the program and as such does not completely own all of the assets, the capacity of the program is reliant on the 14 signatory nations that make up the program (Public Affairs, 2012). The bulk of this research demonstrates that most other Air Forces in the world are facing some form of resource or capacity issue. The demand for pilots is being felt all over the world.

A previous capacity analysis was conducted on Aircrew Training for the Royal Australian Navy (Lallbakhsh, 2018). The study estimated optimal manpower flows under time varying policy and resource constraints. This approach addressed part of the capacity problem in that it prioritized students training to smooth flow the process. While the study is useful to an individual unit, it does not address the current macro batch model that the USAF uses to produce pilots. The USAF produces pilots in classes (a paradigm that has been challenged by UPT-

Next). Class sizes vary in UPT, but the course length does not change. This means that adding more students places a higher demand in the same amount of time. The Lallbakhsh study focused almost entirely on individual students and assigned priority based on previous training accomplished to take the burden off of the rest of the system (Lallbakhsh, 2018). In other words, the study focused on how to unblock a traffic jam. This is done on a micro scale in the Air Force. Classes occasionally fall behind the production timeline for numerous reasons, such as aircraft availability, weather attrition, poor performance, or instructor availability. If a class falls behind, they do not graduate late; instead the program puts more resources towards that particular class. It prioritizes the class ahead of other classes in the hope it can recover the deficit in the future.

There is very little literature available on capacity analysis related to such a complex training program. Operational management problems typically focus on one process at a time. The Air Force pilot training program can be broken down into several smaller processes. First, the program can be broken down into programs such as IFT, UPT, IFF, and FTU. Each of those programs can be broken down further into the phases of the training program; for example, UPT has three phases of training. In each phase of training, there is a syllabus that is broken into blocks of training. To thoroughly determine the capacity of a program, it may be necessary to drill down to several sub-processes to better understand some of the challenges that are being faced. This is the art and science of operational management.

## **Operational Management**

There is nearly limitless research available on operational management. Most of the research available focuses on a specific problem in a process. In other words, the first step in

working through the theory of constraints, finding the constraint, has already been accomplished. This research differs in that it is a model to determine where the constraints exist. Bachouch et al. (2012) created a capacity model to aid in hospital bed planning. The model mapped the decision process for how hospital beds are utilized and took into account limitations on the system such as the gender of patients sharing a room or whether a patient was contagious or not. While this methodology was able to optimize bed planning in hospitals, the study serves as an example of how to determine capacity after the bottleneck has been determined. In this example, the macro process of hospital capacity could potentially be limited by something other than the number of hospital beds. Administrative processing, staffing, or budgeting could be other limiting factors on the hospital's capacity. The style of capacity analysis required for broad programs such as pilot training would need to focus on the macro scale before it determines capacity at the micro level.

The process of determining capacity on the macro level is described as "Capacity Planning Using Overall Factors (CPOF)" (Berry, Schmitt, & Vollmann, 1982). The authors use the example of a Master Production Schedule and measures units in a given time. This can be comprehensively applied to the pilot training production process. In the case of pilot training, the master production schedule is the number of students that graduate in a given time frame. AETC has already set a goal of 1,480 student per year. Berry et al. (1982) also offer techniques that can be applied to the micro level of pilot training such as "Capacity Requirements Planning," in which resources and schedules are pre-placed based on a known demand signal. This level of fidelity exists in the pilot training program. Class sizes differ and instructors are moved around to accommodate greater demand in certain instances.

RAND Corporation created a model for projecting and predicting rated officer management in the Air Force. The model was designed to complement and potentially augment the Air Force Rated Aircrew Management System (AFRAMS) (Terry, Eckhause, McGee, Bigelow, & Emslie, 2019). This model provides data on the health of the rated force and helps senior leaders make decisions on where to focus training and resources. Air Force Personnel Center (AFPC) has the ability to project the number of student pilot candidates for several years. Commissioning sources such as Reserved Officer Training Corp (ROTC) and the United States Air Force Academy (USAFA) enable AFPC to predict future pilot candidate numbers; the ability to forecast allows AFPC to posture the instructor force accordingly. This would also help leaders reposition resources accordingly such as civilian hiring for simulator instruction or added maintenance personnel. Prepositioning of assets would help the Air Force meet a predetermined level of demand.

Strategos Inc. was commissioned to perform a study on manufacturing strategy. They created a ten-station model to mimic a manufacturing plant. They started out with the model balanced with a predetermined level of variability in completion rates. The study found that at low utilization rates the variability had minimal effect but as the utilization rate increased towards 100% the variability had a drastic effect on the amount of inventory that piled up in front of stations (Strategos Inc. , UNK). The study utilized the application of Little's law to illustrate the decrease that occurs in throughput as the utilization rate increases. Figure 3 summarizes the results of the Strategos study.

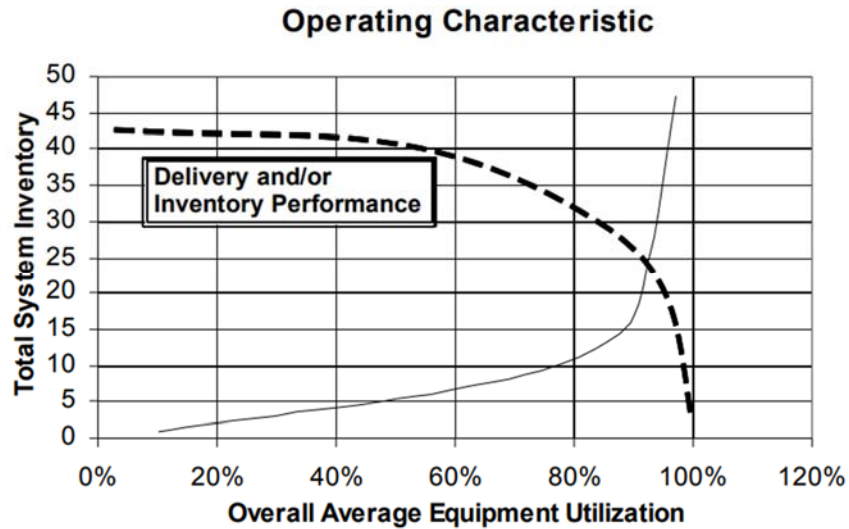

Figure 3. Delivery Performance vs. Utilization Rate (Strategos Inc. , UNK)

The application of Little’s law is just as practical in the pilot production process. As the pipeline gets saturated with more students, it introduces more variability into the process and makes it less efficient. While pilot training runs on a batch system where classes graduate together, there are several instances of students washing back to a different class. This means it is still possible to see a reduction in delivery performance even with scheduled graduation dates.

In an unrelated research project, Pope (2019) utilized Little’s law to conduct a cost benefit analysis of UPT-Next (Pope, 2019). His research, although similar to this research, differs in that it strives to show the financial benefits of gradually phasing in UPT-Next technology. Pope’s (2019) analysis acknowledges and cautions that without further study of how the production pipeline integrates as a whole, it would be foolish to rapidly retool the production pipeline. Specifically, he summarizes that reducing UPT to 6 months would double the FTU and B-Course student load.

## Summary of Literature

The literature in this research shows that there is a need to increase the throughput of pilot production. This is not only the case for the Air Force but is beneficial to the aviation industry as a whole. The U.S. Navy, Army, and Air Force need to address pilot production. The commercial industry has relied too heavily on the Department of Defense to produce enough pilots to sustain growing demand. Military aviation around the world is facing similar struggles trying to recruit, train, and retain pilots. In other words, there is no shortage of parties interested in this research.

There have been several other examples of operational management principles being applied in other industries. Utilizing the theory of constraints and applying Little's Law have been successful in other industries. Pope's (2019) cost benefit analysis of UPT-next is the closest literature to this research and does not fully address the organizational management piece of ensuring that the production pipeline is balanced to maximize throughput. This research will address that gap that exists between pilot production programs. It will address the inter-reliability of each program as a whole. Applying Little's law as it is described in the Adan and Resing (2001) study and described further in the Strategos report appears to be the best way to fully understand the inter-connectedness of the pilot production pipeline (Strategos Inc. , UNK). This research will utilize this approach as a method for analysis.

### III. Methodology

*“Since the strength of the chain is determined by the weakest link, then the first step to improve an organization must be to identify the weakest link.”*

*– Eliyahu M. Goldratt, The Goal: A Process of Ongoing Improvement*

The pilot training pipeline is very large and complex. To put the process into perspective, imagine a student working on a degree program. There are several syllabi that need to be taken into account, each with their own rules and regulations that might dictate the time required for the specific class. Another limitation could be the maximum number of classes or hours that can be done in a given semester. Additionally, the professor’s office hours or laboratory hours might constrain scheduling certain classes. The pilot training process is similar in that there are multiple syllabi, each with certain training events required in a specified order. The resources available are limited and strictly scheduled, such as simulator time, aircraft availability, and instructor availability. This model will demonstrate how to take into account many of those variables and identify additional variables for consideration. To organize this analysis, the research is broken down into the various phases of pilot training. Each phase has its own set of variables that will be crucial in determining the capacity. Many of the broad processes identified in this research have sub-processes that have their own constraints and considerations.

The Air Force has a stated goal of recovering from a deficit of 2,100 pilots. This deficit is across the full spectrum of pilots. Air Education and Training Command (AETC) has been charged with increasing pilot production to 1,480 students per year by 2020 (Aircrew Crisis Task Force, 2020). That is to say that 1,480 pilots graduate Undergraduate Pilot Training (UPT) every

year and progress to follow-on training. These pilots need to be absorbed into follow-on training and eventually into various flying squadrons across the Air Force. To better understand how all of this works, it is necessary to map the production process and then analyze how the sub-processes interrelate. After the production pipeline has been mapped, it will be possible to apply program data to analyze. Finally, as the relationships between programs become clear, it will then be possible to utilize the program data and apply Little's law to determine where inefficiencies exist in the process. Little's law will utilize arrival rates of students into various phases of training in conjunction with program length and cycle time to determine where bottlenecks exist or where they will form.

### **Mapping the process**

The pilot production pipeline is explained in great detail scattered across multiple Air Force Instructions. Depicting the process a student goes through to become a pilot provides a better understanding of the interrelations that exist between the various sub-programs. The processes depicted in this section show the various routes a pilot could take from when they are selected to train as a pilot to the point they have completed training in a major weapon system.

### **Introductory Flight Training**

As mentioned previously, Air Force pilot training is structured in a way that involves students entering the process in a program called Introductory Flight Training (IFT). Some students do not attend IFT because they already have a Private Pilot's License (PPL) and can proceed directly to their respective UPT base. To conduct a capacity analysis, it is important to tackle each of the phases of training separately. Specifically, AETC is concerned with getting

1,480 pilots per year to earn their wings. In order to accomplish this, the student pilots must go through IFT and then UPT as depicted in Figure 4.

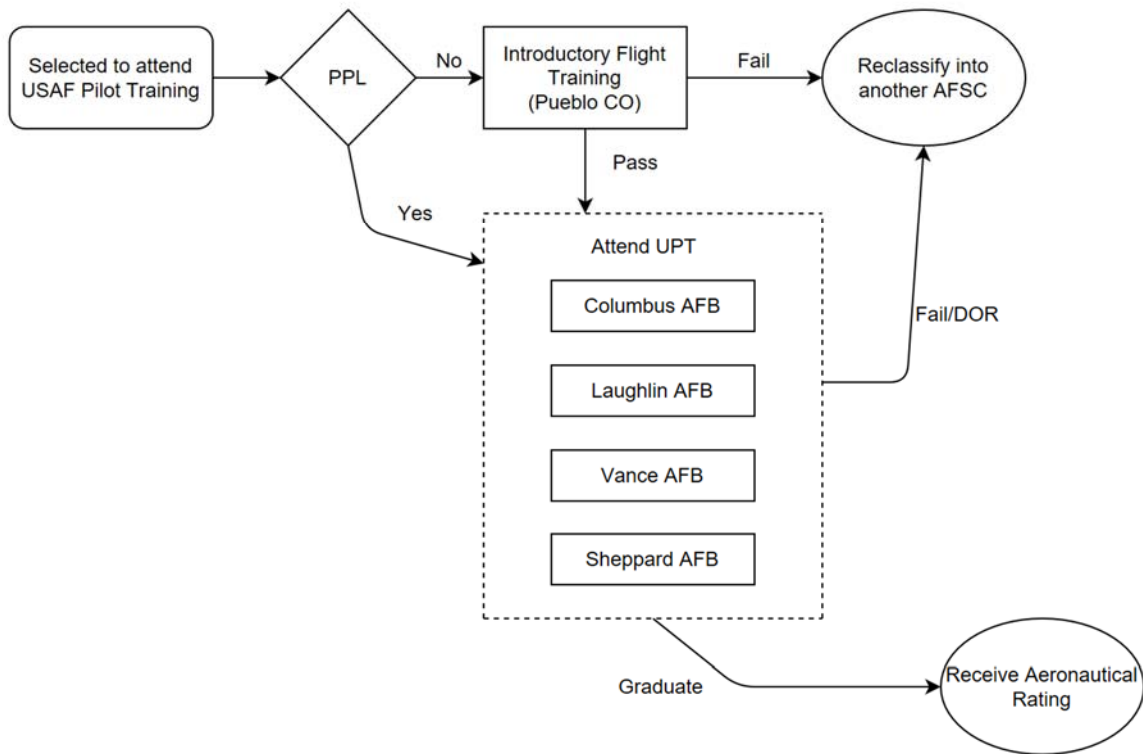

Figure 4. IFT to UPT Process

IFT is a training program offered in one facility in Pueblo Colorado. That means all student pilots who do not have a PPL must go through this facility before they can attend UPT at one of the four UPT bases. Working backwards, if the goal is 1,480 pilots at the end of UPT, it is possible to determine the required number of students at the beginning of training by looking at the historical attrition rates. Utilizing the attrition rates from each of the programs allows Air Force Personnel Center (AFPC) to select the appropriate number of people to attend UPT.

To understand how these various training programs relate, we can apply program data. For example, the number of UPT classes that graduate each year are planned in advance. The number of students per class varies slightly but is typically 28-32 students per class. The length of the program is constant as long as there are no changes to the program. Figure 5 illustrates how the number of classes per year and the time between graduations can be applied to show how students flow from one program to the next. The number in the capacity box is the number of classes per year that each UPT base graduates. The Cycle time is the number of weeks between graduations.

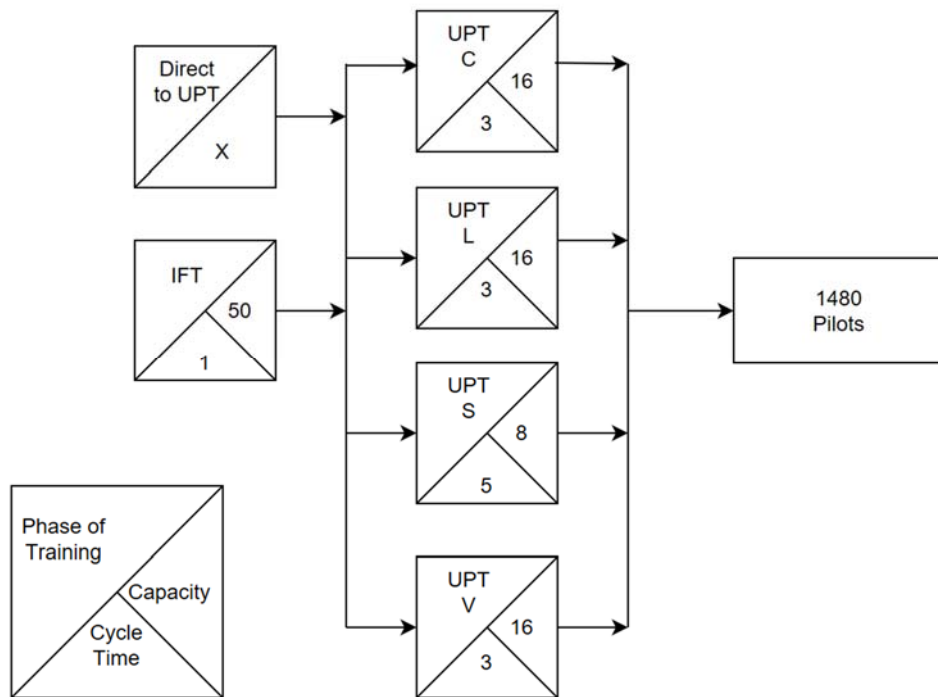

Figure 5. Cycle Time and Classes per Year for IFT and UPT

Currently, three out of four of the UPT bases work in phase and operate on the same cycle time of 3 weeks. This means that when Laughlin has a graduation, Vance and Columbus also have a graduation the same week. IFT graduates a class every week and fills in the UPT pilot slots. This cycle time works well in this phase of training but becomes significantly more complex in follow-on training. A class size typically ranges between 28-32 students. In this example, class sizes of 30 are used except for UPT at Sheppard AFB, which has foreign student graduates that are not a part of the desired 1,480 pilots. UPT at Sheppard typically has eight American students per class.

Utilizing the number of classes per year and the number of students per class and multiplying by the attrition rate of the various programs it would be possible to determine the number of pilots that need to enter training to reach the goal of 1,480 pilots that AETC has set for itself. The throughput at each UPT location, as well as IFT, can be estimated by Equations 1 through 5. The objective function (i.e., goal of 1,480 pilots) is represented by Equation 6. To meet this production goal, the number of IFT and PPL candidates must be greater than the capacity of the UPT bases; this constraint is represented by Equation 7.

$$UPT_C = 16 * 30 * (1 - S_a) = 480 * (1 - S_a) \quad (1)$$

$$UPT_L = 16 * 30 * (1 - S_a) = 480 * (1 - S_a) \quad (2)$$

$$UPT_S = 8 * 8 * (1 - S_a) = 64 * (1 - S_a) \quad (3)$$

$$UPT_V = 16 * 30 * (1 - S_a) = 480 * (1 - S_a) \quad (4)$$

$$IFT = 50 * 30 * (1 - S_a) + PPL \quad (5)$$

$$\sum UPT_C, UPT_L, UPT_S, UPT_V \geq 1480 \quad (6)$$

$$\sum IFT, PPL \geq \sum UPT_C, UPT_L, UPT_S, UPT_V \quad (7)$$

In equations 1 through 7, the terms are defined as follows.

$$UPT_C = (\#classes/yr * class\ size * (1 - Sa)) = \#Graduates\ at\ Columbus\ AFB$$

$$UPT_L = (\#classes/yr * class\ size * (1 - Sa)) = \#Graduates\ at\ Laughlin\ AFB$$

$$UPT_S = (\#classes/yr * class\ size * (1 - Sa)) = \#Graduates\ at\ Sheppard\ AFB$$

$$UPT_V = (\#classes/yr * class\ size * (1 - Sa)) = \#Graduates\ at\ Vance\ AFB$$

$$IFT = (\#classes/yr * class\ size * (1 - Sa)) = \#Graduates\ from\ IFT$$

$$PPL = \#students\ with\ a\ PPL\ headed\ direct\ to\ UPT$$

$$Sa = Student\ attrition\ rate$$

Currently, the capacity and cycle times of UPT are balanced enough to prevent a significant backlog concern. However, if AETC were to bump up the number of students in UPT, IFT would also have to grow in capacity to accommodate the additional students. This concept also holds true for the rest of the production pipeline. If UPT were to exceed the capacity of the FTUs/B-Courses, there would be a backlog of pilots awaiting further training at their follow-on assignments. With a cycle time of one week, IFT can quickly fill UPT pilot slots if one were to open up unexpectedly.

### **Undergraduate Pilot Training**

As previously stated, AETC has the desire to produce 1,480 pilots a year. Currently, the production pipeline follows a batch model approach. This means student production is not measured by the individual but rather by the class. The capacity and production pipeline of UPT by itself can be modeled in a similar fashion to that of IFT to UPT. The various phases of training can be broken down into the respective capacity and cycle times for the corresponding

syllabus of that phase. The syllabus can be broken down from there to the individual training event to determine where the bottlenecks exist in a syllabus.

Sheppard AFB is different from the other three UPT bases in that the syllabus is longer in each phase of training. However, the same process would be applicable to understanding the cycle time of the program. It gets more complicated when you combine the cycle time of all four UPT programs to get an overall cycle time. Figure 6 shows the similarities and differences in how ENJJPT is organized. What is not depicted is that the syllabus is longer and as a result has a longer cycle time with fewer classes per year.

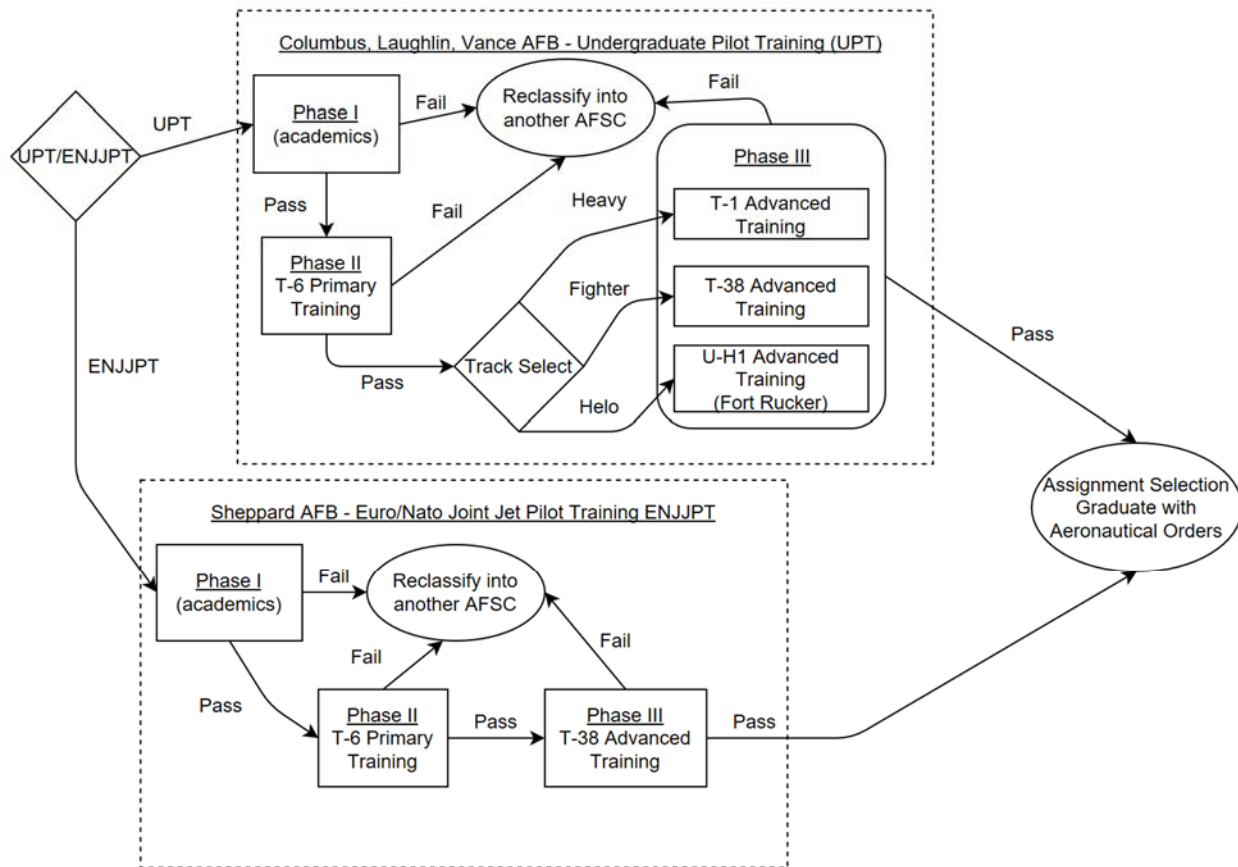

Figure 6. UPT Phase I - Phase III

UPT is well coordinated with similar cycle times between phases. The cycle time difference between Phase I and Phase II is a period where Phase II instructors catch up on Continuation Training requirements or help out in other classes. For the most part, students do not have any available time between phases and flow smoothly to the next portion of the program. In some cases, if a student completed a phase early due to numerous variables, that student might have some time where he or she is not accomplishing syllabus events. In these cases, the time a student is not working on a syllabus event should never exceed the cycle time of 3 weeks. The variable that changes between Phase II and Phase III is the number of students per class. T-38 training, for example, still graduates 16 classes a year at each UPT base; however, the class sizes in T-38s are smaller than those in T-6s. In other words, the students from Phase II get distributed out over multiple Phase III programs. While the Phase III programs are smaller, collectively they have the capacity to absorb the students from Phase II. This flow of pilots is shown in Figure 7, and the accompanying equations are shown below for the number of students completing each phase.

$$P_1 = n * (1 - S_a) = \text{Number of students that complete Phase I} \quad (8)$$

$$P_2 = P_1 * (1 - S_a) = \text{Number of students that complete Phase II} \quad (9)$$

$$P_3 = P_2 * (1 - S_a) = \text{Number of students that complete UPT} \quad (10)$$

$$P_3 = (T_{38} * (1 - S_{a38})) + (T_1 * (1 - S_{a1})) + (U_1 * (1 - S_{au1})) = \text{UPT}_x \quad (11)$$

In equations 8 through 11, the terms are defined as follows.

$n = \text{number of students}$

$S_a = \text{Student attrition rate per phase (number denotes airframe)}$

*ex:*  $S_{a38} = \text{Student attrition for T38s}$

$x = \text{Specific UPT base (c, l, s, v)}$

Similar to the IFT to UPT transition, program data such as the number of classes per year, class size and cycle time can be utilized to determine the arrival rate of students throughout the various phases of UPT. This information can also be utilized at the end of phase three to determine the arrival rate of students into follow on FTU and B-Course training. This process is depicted in Figure 7.

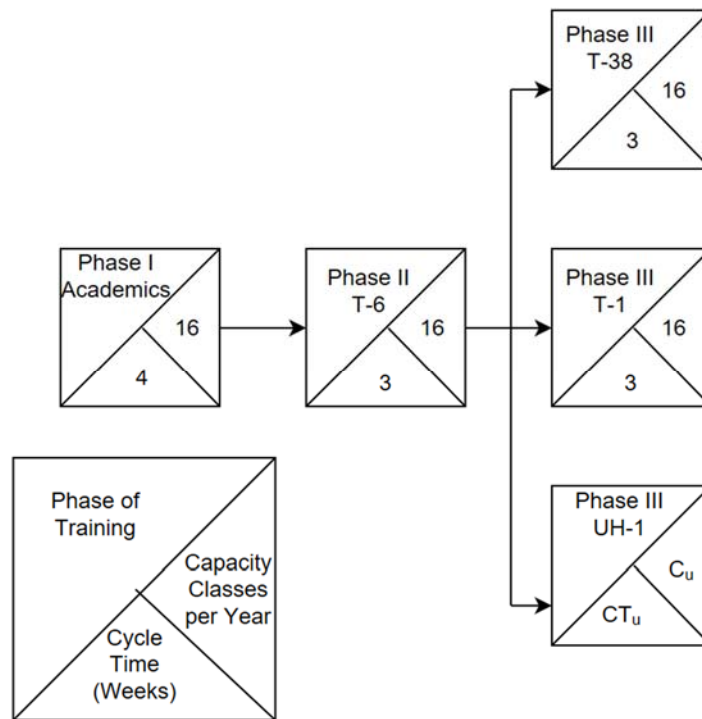

Figure 7. Cycle Time and Classes per Year for UPT Phase I - Phase III

### Post UPT Training

Understanding the process gets significantly more complex following UPT. Newly minted pilots progress to follow-on training. The UPT graduates are distributed to Formal Training Units (FTU), Introduction to Fighter Fundamentals (IFF), and B-Courses. This process is similar to the way that Phase II pilots from UPT were distributed into different Phase III programs but on a much larger scale. As mentioned previously, three out of the four UPT bases

have graduation at the same time. That means that potentially 90 pilots will need to be distributed to follow-on assignments every 3 weeks. The follow-on training programs are typically smaller and take smaller class sizes. There are more Formal Training Units and B-Courses than there are UPT which makes up for the smaller class sizes. Crew aircraft such as tanker and cargo aircraft will be able to accept students on a crew pairing basis but might have several crews being trained in parallel. Fighter courses and Pilot Instructor Courses (PIT) will typically wait until a class is filled before beginning follow-on training. This opens up the potential for a pilot to wait the entire cycle time of an FTU/B-Course before they can begin follow-on training. Because of the drastic differences in cycle time and capacity, a pilot could wait a significant period of time before continuing with training. Figure 8 shows how the 1,480 pilots would be distributed to the follow-on FTU/B-Courses. Utilizing program data, it is possible to determine the number of students that need to be distributed every week. This data gives us an accurate arrival rate of students showing up to FTU/B-Course.

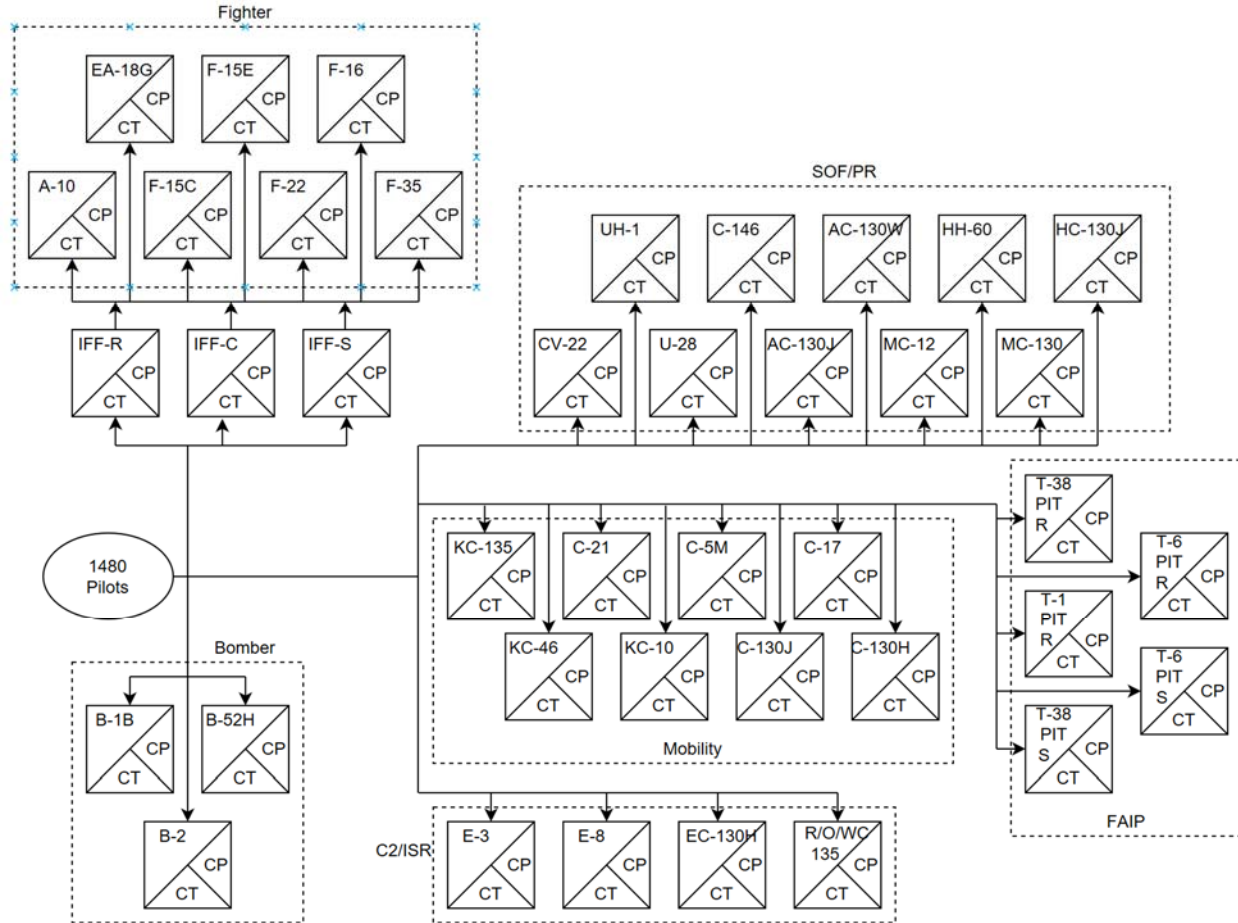

Figure 8. Post Graduate Pilot Training

This is where the analysis gets more complex. UPT in general follows a 3-week cycle time. That means that not all 1,480 pilots are available at a given time for follow-on training. Graduated Pilots are available at a rate of  $P_3/CP$  (total number of graduates from Phase 3 divided by number of classes per year). However, not all the cycle times are the same at the UPT bases. So a more accurate expression is:

$$\sum \left( \frac{UPT_C}{16} \right) + \left( \frac{UPT_L}{16} \right) + \left( \frac{UPT_V}{16} \right) + \left( \left( \frac{3}{5} \right) \left( \frac{UPT_S}{8} \right) \right) \quad (12)$$

(Sheppard has a different cycle time so it was multiplied by 3/5)

This equates to  $94.8 \cdot S_a$  students every 3 weeks or 31.6 students per week. Assuming the students are distributed evenly across all 38 programs, that gives an average arrival rate for each program of 0.83 students per week. This is an assumption and can be adjusted based on actual program data. In reality, there is a higher rate of students entering a C-17 program than a student entering an F-35 program. However, Little's law holds true even when utilizing program averages.

These students need to be distributed over the B-Courses based on what MWS the student was assigned to 3 weeks prior. It is important to note that not all of the B-courses will have a class starting immediately. In the case that a student has to wait for a class start date, the maximum length they would have to wait would be the cycle time. If a B-Course only offers a class 1-2 times a year, they will have a longer cycle time, 26-52 weeks respectively. That means a pilot awaiting training could potentially wait that long until the next class starts.

## **Summary**

After mapping the pilot production pipeline and assigning program data to cycle times, classes per year, and class sizes, it is possible to determine an arrival rate of students entering follow-on training. On average, 31.6 students per week will need to be distributed into one of the 38 training units following UPT graduation. This arrival rate can be applied to Little's law to forecast the average time a student will spend in the training pipeline. Little's law can be utilized to determine the number of students in the training program, the number of students awaiting training, and the time they spend in training.

## IV. Analysis and Results

*“The more you sweat in peace, the less you bleed in war”*

*– General Norman Schwarzkopf, U.S. Army*

The USAF is interested in increasing pilot production. As mapped out and demonstrated in Chapter III, that includes much more than UPT. To increase production of pilots for the USAF, capacity would need to allow it across the full spectrum of training. In simple terms, there are two ways to increase the throughput of a pipe. The flow rate of a pipe is inversely proportional to the length of the pipe. So if you shorten the pipe you will get more throughput per unit of time. The other way to increase throughput of a pipe is to increase the diameter of the pipe. If you increase the diameter of a pipe, the throughput increases by a factor of  $x^4$  where  $x$  is the change in pipe diameter. As shown in Figure 9, this concept is applicable to course length and cycle times of pilot production programs as well.

By reducing batch size and cycle time, it is possible to streamline a production process and reduce the inventory in the system. In this case, the inventory is the number of student pilots. The production process flows smoothly when the cycle times match up; when they do not match up though, it leads to a decrease in productivity on the part of the student. For example, F-22 B-Course only has one class a year. If a student were to earn an F-22 assignment early in the fiscal year, that student would have to wait until a complete class is formed which could be a significant period of time. Offering smaller classes more frequently could reduce the amount of time a pilot waits between completing Introduction to Fighter Fundamentals (IFF) and B-course or UPT and FTU.

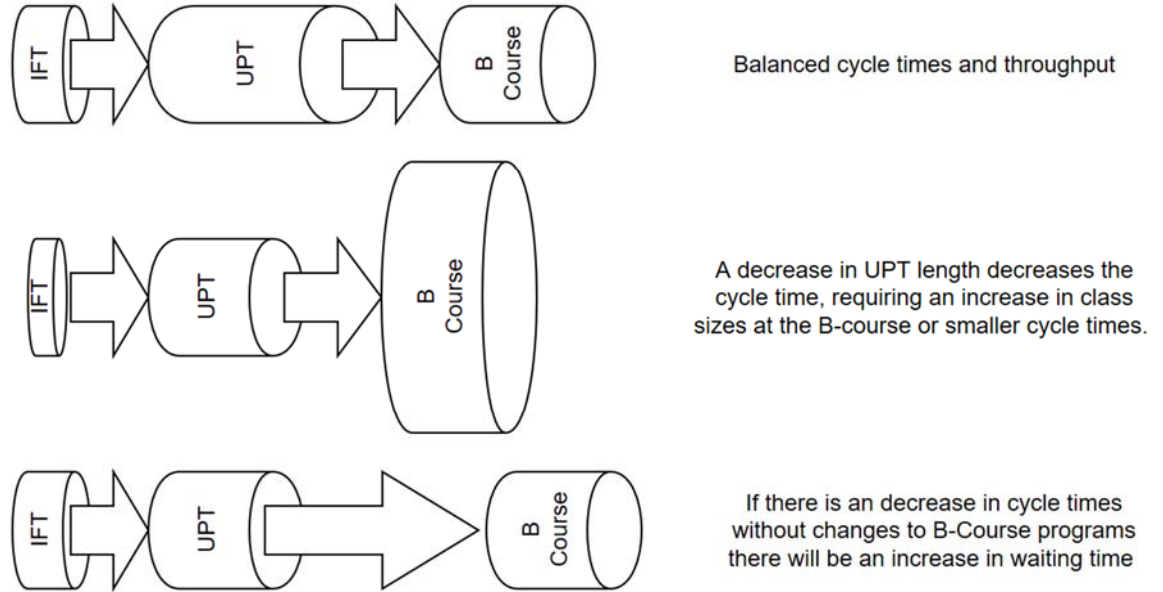

Figure 9. Throughput Concept

Little's law backs up this analysis: Little's law states that the average number of pilots in the system is equal to the arrival rate multiplied by the time in the system. If the arrival rate increases but the training completion rate does not increase proportionally, then there will be a backlog of pilots. Given a known B-Course length and the rate that UPT graduates are arriving, it is possible to determine the total number of students in the system ( $L$ ) using Equation 13. Cycle time and class size can be used to determine the service rate which can then be used to determine the number of students within B-Course ( $\rho$ ) (could be multiple classes) using Equation 14. The average time in the system ( $W_s$ ) can be determined using Equation 15. The average time a student waits to begin B-Course training ( $W_q$ ) and the average number of pilots awaiting B-Course training ( $L_q$ ) can be determined using Equations 16 and 17, respectively. Finally, the average number of pilots currently in B-Course training ( $L_s$ ) can be expressed using Equation 18.

$$L = \lambda * W \quad (13)$$

$$\rho = \frac{\lambda}{\mu} \quad (14)$$

$$W_s = \frac{1}{\mu - \lambda} \quad (15)$$

$$W_q = \frac{\rho}{\mu - \lambda} \quad (16)$$

$$L_q = \frac{\rho\lambda}{\mu - \lambda} \quad (17)$$

$$L_s = \frac{\lambda}{\mu - \lambda} \quad (18)$$

Where  $L$  is the average number in the system,  $\lambda$  is the arrival rate,  $W$  is the average time in the system,  $\rho$  is the average number in service, and  $\mu$  is the average service rate.

If production were to increase in UPT, the arrival rate of students at the B-course would increase at a rate proportional to the cycle times. Since the length of the B courses does not change, the average number of students in the system would increase as the arrival rate increases. This would result in an increase in the average time a student waits to begin B-Course training. In order to prevent wait times to start training from increasing, it would be necessary to increase the service rate of the B-Course. That can be done by either increasing class sizes or offering more frequent cycle times. To do either of these would mean more resources are required at the B-Courses.

The arrival rate of the B-Courses would increase at a proportional rate to the decrease in UPT. Air Education and Training Command has two initiatives to increase UPT throughput. UPT-Next was a test bed to utilize virtual and augmented reality training devices to produce a pilot in 6 months. If this model were to be implemented, it would double the arrival rate to the B-Courses. Another initiative that AETC recently rolled out was an initiative that took some of the

lessons learned from UPT-Next and used a targeted approach to reducing the UPT syllabus. This approach would graduate pilots in 9 months and cause a 25 percent increase in the current arrival rate.

The current arrival rate of pilots to the B-Courses was determined in Section III to be 0.83 students per week if distributed evenly over the 38 B-Course programs. The B-Courses are currently right at their limit and can produce pilots at a rate that limits a significant buildup of students awaiting training. The instances where waiting does exist is more dependent on phasing the cycle times closer together from one program to another. Table 1 arranges the arrival rate of students to B-Course training with the graduation rate of pilot from B-Course. Utilizing the three scenarios, it is possible to compare the number of students in the system as well as average wait times of students awaiting training.

Table 1. Arrival vs. Departure Rate

	UPT	UPT 2.5	UPT-Next
Student Arrival Rate	0.83	1.03	1.66
Student Graduation Rate	0.83	0.83	0.83

Table 1 applies a 25 percent increase in arrival rate to simulate UPT-2.5 and a 100 percent increase in arrival rate to simulate UPT-Next. These arrival rates are expressed in students per week. Taking the difference between the arrival rate and graduation rate, it is possible to determine the increment that the que is building. UPT-2.5 gains an extra student in training every five weeks, where UPT-Next gains an extra student per week. This relationship is displayed in Figure 10. The slope of the line is the rate at which the queue is building.

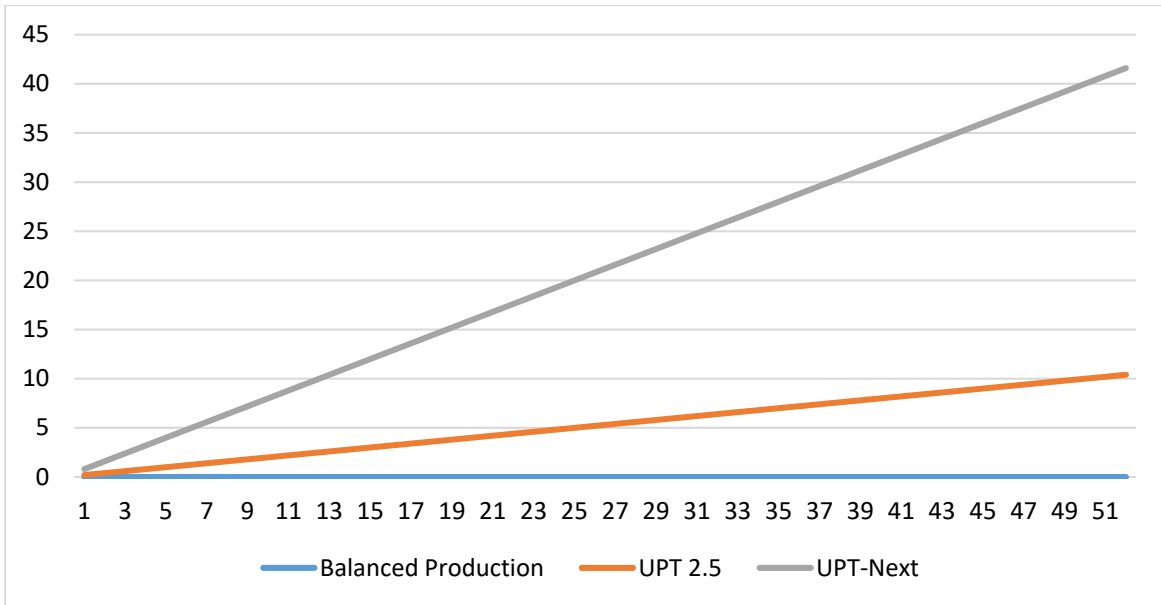

Figure 10. Pilots Awaiting Training

If efficiencies are made in UPT for pilots to turn around and wait to start follow-on training, this would be counterproductive to the overall goal of training future combat pilots. There are a few ways that this is less efficient overall. Financially, training aircraft are more economical to fly than Major Weapon Systems such as fighter, tanker and cargo aircraft. Figure 11 depicts the operating costs of some Air Force airframes. The operating cost of the T-6, T-38, and T-1 are significantly less than the follow-on aircraft. Reducing training up-front to create more pilots, only to invest more flying hours in them later, is not being more efficient.

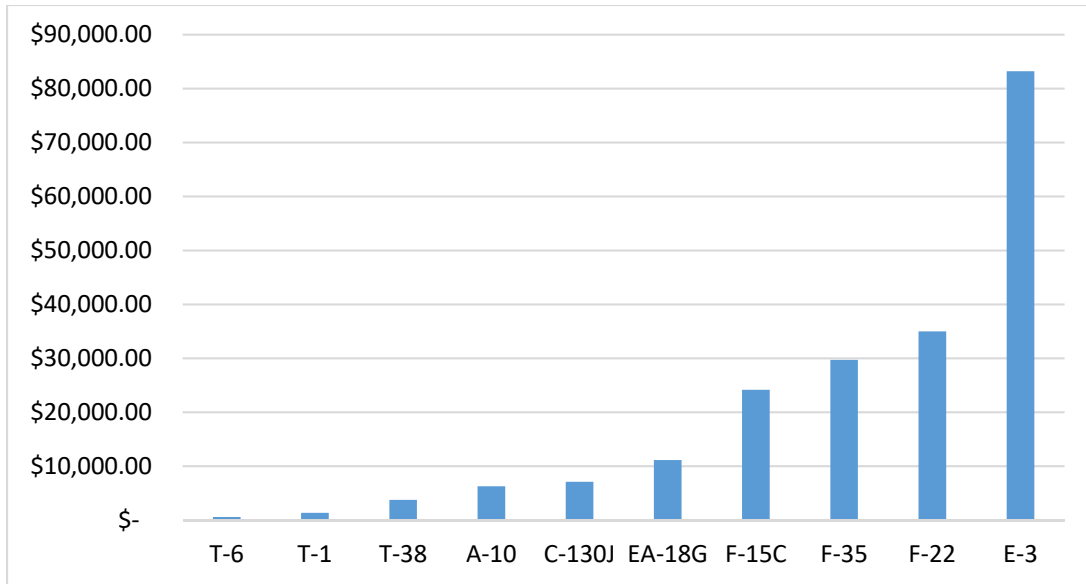

Figure 11. Cost per Flight Hour

A previous change that has been made to UPT syllabi has been to decrease the mission familiarization training offered in Phase III and to decrease the formation block in Phase II. By shortening the syllabus, this allowed more students to graduate on time. Those students then show up to a B-Course training program with less training and familiarization for that skill set. To augment the deficiencies, B-Courses can either offer more sorties or they can choose to eliminate a student from training who is not meeting standards. The further into the pilot training pipeline a student is eliminated the bigger the cost. If a B-Course were to offer additional training, it would also cost more. There is a tradeoff between increasing the resources allocated to the B-Courses to decreasing wait time. Allocating enough resources so that there is not ever a wait would come at an extremely high cost. Waiting for an extended period of time also comes at a cost. Figure 12 illustrates the relationship that exists between added service and waiting time.

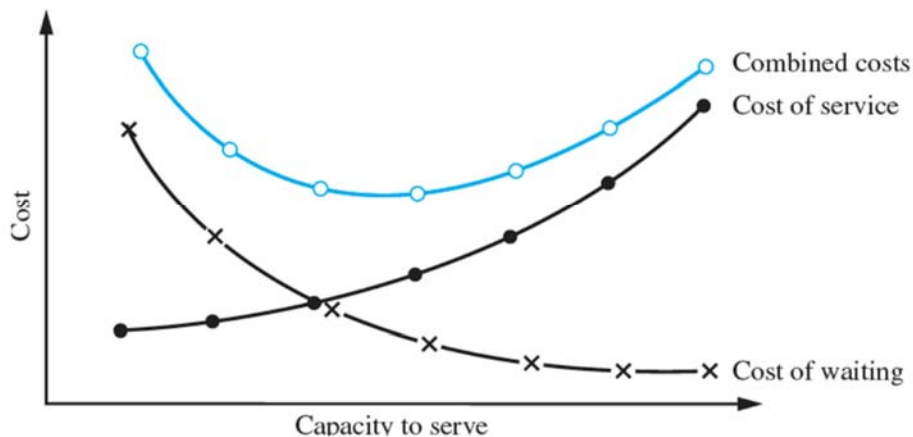

Figure 12. Cost of Service vs. Cost of Waiting

There is a significant increase in cost by shifting training to the B-Courses or by eliminating a pilot late in the production pipeline. Shrinking the length of the UPT part of the program has the same effect because of the added burden it puts on the B-Courses. Instead of shrinking the length of the pipeline, if the entire pipeline were to increase in diameter, it would have the same effect but spread the burden in a more economical manner.

### Investigative Questions Answered

RQ 1: Where is the bottleneck in the pilot production program?

Hard data was not available during COVID-19 operations; therefore, this question could not be answered definitively. The researcher did not have access to the appropriate servers from home. The research sponsor has the data to plug into the model but was understandably tied up with the COVID-19 crisis. This is an area for future research. However, what this model does show is that increasing throughput in one area of the pipeline does not increase throughput for the entire training program. As mentioned in Chapter I, the five focusing steps of the theory

of constraints represent an iterative process that needs to be reassessed regularly. Alleviating one constraint may cause a different constraint to appear. In the case of this research, alleviating the perceived constraint of UPT without also adjusting B-Course training would only cause a bottleneck entering graduate training.

RQ 2: If AETC was able to increase pilot production to 1,480 pilots per year, would the rest of the pipeline be able to handle it?

Once again, there is no definitive answer due to gaps in data. However, the research does show the relationship that would exist regarding production efforts. If production efforts focus on shrinking the pipeline, there would be a much higher demand on B-Courses and a much higher cost. Balancing the pipeline and aligning cycle times seem to be the most efficient way to increase throughput without adding additional waste of either time or resources somewhere else in the production process. Currently, if UPT were to increase throughput in a manner consistent with UPT-Next or UPT-2.5 without adjusting B-Course training, there will be a considerable backlog of pilots awaiting follow-on training.

RQ 3: What are the financial implications of increasing UPT capacity?

If done correctly, increasing UPT capacity will help bring an end to the pilot shortage. It is necessary for the Air Force to develop pilots more expeditiously than it has in the past. However, increasing the capacity of UPT without increasing the capacity of follow-on training programs would not lead to more pilots faster. Initially shrinking pilot training would provide up front financial benefits but could potentially cause more downstream costs. Understanding the relationship that exists between the programs is important in regards to the overall cost of

training a pilot. Saving thousands of dollars upfront could potentially cost hundreds of thousands further into the training pipeline. A proportional increase in capacity across the entire production pipeline would be the most efficient way to produce more pilots.

## **Summary**

This research provides a model that can be applied to capacity analysis at many levels of pilot production. It can be used at the local level to determine where a bottleneck exists within a syllabus. It can be used to determine the cycle times of training events and align the syllabus to maximize throughput. After the local syllabus level, it can be applied to the program level such as UPT where the cycle times of the phases of training can be determined and adjusted to ensure maximum throughput. This model can then be applied to the macro level where several programs can be analyzed to determine cycle times and coordinate throughput. This macro level is where the most waste can be eliminated. The length of time a pilot waits between training can be decreased if cycle times are in rhythm with each other. This model also demonstrates how decreasing the length of UPT has drastic effects on B-Course capacity and pilot production costs.

The theory of constraints suggests that chasing local efficiencies makes the bigger picture less efficient. UPT might be able to increase throughput but with no coordination or changes to B-Course all the efficiencies that are gained will be wasted while a pilot waits to start B-Course training. Trading curriculum in UPT for added curriculum in follow-on training is less efficient. Exchanging training in an aircraft that costs \$2k to operate per hour for an aircraft that cost \$18k dollars an hour to operate is not efficient. The cost of awaiting training has the potential to negate all the cost and time saving initiatives gained in UPT. If a pilot has to wait a long period

of time between training programs, it does not make them mission ready any faster.

Additionally, if a pilot has to regain proficiency because of an extended period of non-flying, some of the savings seen in UPT will be lost with additional training in the FTU and B-Courses.

## V. Conclusions and Recommendations

*“Never tell people how to do things. Tell them what to do and they will surprise you with their ingenuity”*

*– General George S. Patton, U.S. Army*

This research presented several challenges. The pilot production pipeline is a very complex conglomeration of smaller training programs. Each smaller program has considerations and constraints that are difficult to account for without being a program expert. The application of this model was significantly hindered by the global health pandemic caused by COVID-19. Most of the data needed to apply this model can be found in multiple training syllabi that exist at local levels. However, the concept does not change with a lack of data. The relationship between the various training programs is undeniable in that a small change upstream can have drastic consequences downstream.

### **Conclusions of Research**

This research uses broad brush strokes to demonstrate the relationship that exists between training programs within the pilot production pipeline. Additionally, the research provides a method that can be applied at many levels to determine ideal cycle times for training programs. This ability will allow Air Force leaders to proportionally grow the entire production pipeline in an efficient manner.

## **Significance of Research**

This research maps out the pilot production pipeline in a manner that makes it easier to determine the effects of decisions made in individual training programs. In other words, the model shows the effect of changing class sizes or length on the rest of the production pipeline. This would allow a decision-maker to forecast where resources would need to be placed before issues arise. For example, if shortening a training program would cause a massive backup in another training program due to manning shortfalls or available aircraft, the decision-maker could allocate additional resources before the backup occurs. It allows a decision-maker to be proactive instead of reactive.

In addition to providing a method of analysis, this research demonstrates that the current methods being utilized to streamline the production pipeline are not sufficient to increase the rate of pilot production. Current efforts only focus on one aspect of pilot production and as a result will not increase the overall throughput of mission ready pilots. If not monitored closely, these efforts could potentially sabotage some of the cost saving initiatives that prompted pilot training changes in the first place.

## **Recommendations for Future Research**

Future research could use this model and apply it to each syllabus in the model. This would determine the capacity of each individual program. From there, applying the cycle times, class sizes, and number of classes each year would make it possible to determine the capacity of the entire program. Utilizing the program data and applying it to this model would allow a future research effort to provide recommendations on how often a formal training unit should offer a class or how many students should be in each class.

This research makes an assumption that training events trimmed from UPT need to be made-up in future training. Future research could include a regression analysis on training trends. Has the number of sorties in B-Courses increased in relation to the decrease in UPT sorties? If there is statistical correlation, it can then be applied to the cost differential between aircraft. This has the potential to show leadership that small program efficiencies do not always correlate to greater system efficiency. This area of future study would be the most beneficial to the Air Force pilot production program. The data for this analysis exists within the Graduate Training Integration Management System (GTIMS). As UPT programs such as UPT-Next and UPT-2.5 are rolled out, training quality will need to be closely monitored to ensure the quality of the pilot has not been sacrificed for time or cost savings initiatives that could prove more costly in the future.

## **Summary**

This research was conducted to better understand production efforts in relation to the pilot crisis the Air Force is currently facing. With a pilot deficit of 2,100 pilots, pilot production is a growing concern in the Air Force. Air Education and Training Command has been working tirelessly to reevaluate training paradigms for the past 75 years. UPT-Next and UPT-2.5 are two of the efforts that AETC has developed to help produce more pilots. To better understand the effects that these initiatives might have on the production pipeline, this research examined best practices within the United States Military, the commercial industry, and foreign military agencies, as well as organizational management practices, to analyze other programs as complex as the pilot production process.

Utilizing the Theory of Constraints, this research set out to identify the bottleneck in the pilot production pipeline. The first step was to map out the production pipeline in its entirety.

Mapping the process helped to visualize and understand the complexity of such a large training program that is made up of many smaller independent processes. Mapping this process was important to show the relationship that exists between the various production programs. Applying Little's law to this relationship demonstrated that if production efforts are not increased as an entire process, there will be little to no benefit of increasing UPT production by itself. The increase in pilots waiting to start training is proportional to the decrease in UPT length due to the higher arrival rate of students into follow-on training. This additional waiting time does nothing to create mission ready pilots faster and has the potential to cost significantly more to regain proficiency that was lost while awaiting follow-on training. The UPT initiatives are truly groundbreaking and will continue to benefit the Air Force and transform the way that pilots are trained. This research shows that it must be done throughout the production pipeline to truly benefit from the reduction in time and cost that these initiatives boast.

## Appendix A

Aviate partners currently include:

- Embry-Riddle Aeronautical University
- Western Michigan University
- Lufthansa Aviation Training Academy
- University of North Dakota
- Hillsboro Aero Academy
- US Aviation Academy
- FlightSafety International
- Ameriflight
- Boutique Air
- ATP Flight School
- ExpressJet
- CommutAir
- Air Wisconsin
- Mesa Airlines
- Florida Institute of Technology



## Appendix B: Quad Chart

### Abstract

A worldwide shortage for pilots combined with an increasing global demand for air transportation has left the United States Air Force 10% short of required pilot training numbers. Air Education and Training Command (AETC) is working hard on the front line to increase training capacity. The complexity of the training process has made it difficult to smooth flow. A review of literature on pilot production, organizational management and queuing yielded the need to model the pilot production process to better understand the relationship between sub-branches of the training pipeline and helps to determine some of the limiting factors that constrain capacity. This model maps all the sub-processes in the pilot production pipeline to understand how they relate. Applying Little's Law to this production map demonstrates how current production initiatives will not solve the production problem. Increasing the throughput of one part of a process does not necessarily increase the throughput of the entire production program.

### Methodology

This research utilized a quantitative analysis of production queuing to understand the relationship between training programs. Mapping out the production process and utilizing cycle times and courses per year it was possible to show how the training programs interrelate. The additional application of Little's Law to program data showed how the sub-programs interact.

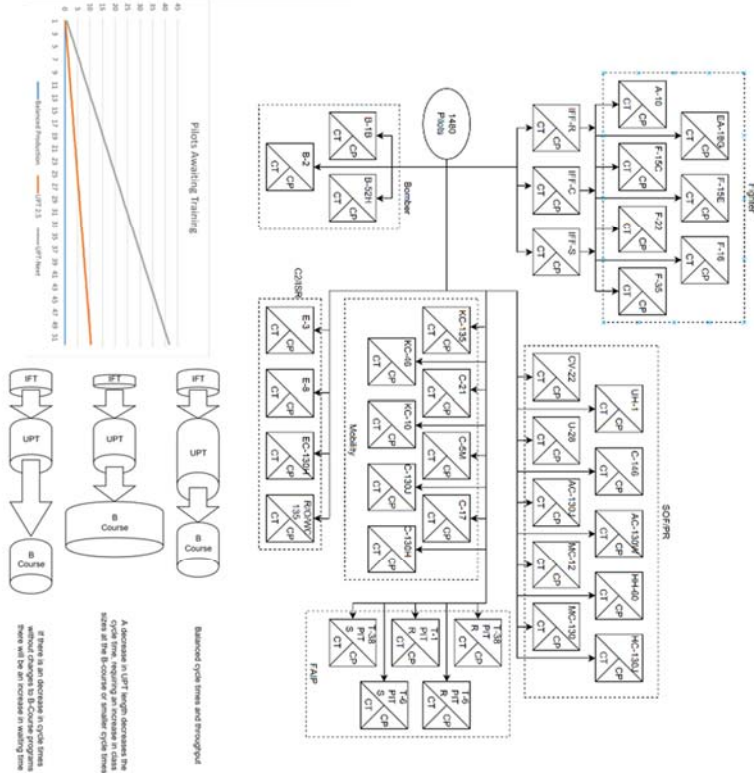

Major Derek Colbath  
 Advisor: Dr. Alfred Thal, PhD  
 Advanced Study of Air Mobility (ENS)  
 Air Force Institute of Technology

### Results

1. Mapping the pilot training process and determining the cycle times and classes per year was beneficial in determining the relationship between various training programs.
2. The length of a training program is directly related to the throughput of that program. Therefore if the program is decreased in length the throughput will go up. This ultimately leads to a larger arrival rate of students to follow on training.
3. If the follow on training programs accept students at a faster rate without increasing their own throughput students will find increasing wait times between training programs.

### Recommendations

4. AETC should closely monitor wait times between training programs
5. AETC should monitor student performance in follow on training to ensure that reduction in pilot training events does not trigger and increase in B-Course or F-TU requirements.
6. More resources should be allocated to FTU/B-course training to increase student throughput. This would balance the training programs.

### Conclusions

The research displayed the relationship between UPT and follow on B-Course/FTU training. Current efforts by AETC to shrink UPT training will increase the arrival rate of students to the B-Courses and FTUs if this transition is not closely monitored a significant delay between training can develop.

## References

- Adan, I., & Resing, J. (2001). *Queueing Theory*. Eindhoven, The Netherlands: Department of Mathematics and Computing Science, Eindhoven University of Technology.
- airsceneuk. (2018). *Top 10 Strongest Air Forces in the world*. Retrieved from Air Scene: <https://www.airsceneuk.org.uk/airshow06/morocco/morocco.htm#>
- Bachouch, R., Guinet, A., & Hajiri-Gabouj, S. (2012). An Integer Linear model for hospital bed planning. *International Journal of Production Economics*, 833-843.
- Berry, W., Schmitt, T., & Vollmann, T. (1982). Capacity Planning Techniques for Manufacturing Control Systems: Information Requirements and Operational Features. *Journal of Operations Management*, 13-25.
- Callander, B. D. (2008, August 16). And Now, the Pilot Shortage. *Air Force Magazine*.
- DCI. (2020, March 24). *The Different Step to Become a military Pilot in France*. Retrieved from DCI: <https://www.groupedci.com/2016/02/24/the-different-steps-to-become-a-military-pilot-in-france/>
- Edelstein, D. M. (2004). Occupational Hazards: Why Military Occupations Succeed or Fail. *The MIT Press*, 49.
- Gall, P. (2018, July 13). The U.S. has a shortage of pilots - and its going to get worse. *Market Watch*, p. Unk.
- Goldratt, E. (1984). *The Goal*. New York City: North River Press.
- Hebert, C. &. (2008, May 10). The Pilot Shortage Abruptly Ends. *Air Force Magazine*, p. unk.
- IAF. (2018, February 1). *How IAF Pilot Take Off*. Retrieved from Israeli Defense Force: <https://www.idf.il/en/minisites/israeli-air-force/how-iaf-pilots-take-off/>
- Josephs, L. (2019, Oct 3). *United Airlines ramps up recruitment to hire 10,000 pilots over the next decade*. Retrieved from CNBC: <https://www.cnbc.com/2019/10/03/united-airlines-ramps-up-recruitment-to-hire-10000-pilots-over-next-decade.html>
- Lallbakhsh, M.-H. S. (2018). Capacity Analysis for Aircrew Training Schools - Estimating Optimal Manpower Flows Under Time Varying Policy and Resource Constraints. *IEEE*, 2285-2296.
- Losey, S. (2019, April 1). VR flight training goes international: Brits Join Pilot Training Next. *Air Force Times*, p. unk.
- Maucione, S. (2019, April 23). Navy's Pilot Shortage May be Shored up by 2023, but then the Real Challenge Starts. *Federal News Network*, p. unk.

- Maucione, S. (2019, April 15). New Study Shows Grim Outlook for Future of Air Force Pilot Shortage. *Federal News Network*.
- Pawlyk, O. (2020). The Air Force's Pilot Shortage Got Worse in 2019. *Military.com*.
- Pope, T. (2019). *Cost Benefit Analysis of Pilot Training Next*. Wright-Patterson Air Force Base, Ohio: Air Force Institute of Technology.
- Public Affairs. (2012, October 17). *Euro-NATO Joint Jet Pilot Training Program (ENJJPT)*. Retrieved from Sheppard AFB: <https://www.sheppard.af.mil/Library/Fact-Sheets/Display/Article/367537/euro-nato-joint-jet-pilot-training-program-enjjpt/>
- Sprys, J. C. (2018). *Pilot Training Next: A Case Study for Air Mobility Command*. Wright-Patterson Air Force Base, Ohio: Air Force Institute of Technology.
- Strategos Inc. . (UNK). *Capacity, Inventory, Variability and Manufacturing Strategy*. Kansas City, MO: Strategos Inc.
- Terry, T., Eckhause, J., McGee, M., Bigelow, J., & Emslie, P. (2019). *Projecting Air Force Rated Officer Inventory Across the Total Force*. Santa Monica, CA: RAND Corporation.
- United Airlines. (2020, February 05). *United Hub*. Retrieved from United Hub: <https://hub.united.com/2020-02-05-united-airlines-to-become-only-major-u-s-carrier-to-own-and-operate-a-flight-training-academy-focused-on-training-and-developing-aspiring-pilots-2645042553.html>
- VanHoose, R. (2012). *Are Pilots Graduating SUPT Today Meeting AMC's Current and Future Needs*. Montgomery AL: Air University.

**REPORT DOCUMENTATION PAGE**

*Form Approved*  
OMB No. 0704-0188

The public reporting burden for this collection of information is estimated to average 1 hour per response, including the time for reviewing instructions, searching existing data sources, gathering and maintaining the data needed, and completing and reviewing the collection of information. Send comments regarding this burden estimate or any other aspect of this collection of information, including suggestions for reducing the burden, to Department of Defense, Washington Headquarters Services, Directorate for Information Operations and Reports (0704-0188), 1215 Jefferson Davis Highway, Suite 1204, Arlington, VA 22202-4302. Respondents should be aware that notwithstanding any other provision of law, no person shall be subject to any penalty for failing to comply with a collection of information if it does not display a currently valid OMB control number.  
**PLEASE DO NOT RETURN YOUR FORM TO THE ABOVE ADDRESS.**

<b>1. REPORT DATE (DD-MM-YYYY)</b> 06/05/2020	<b>2. REPORT TYPE</b> Graduate Research Paper	<b>3. DATES COVERED (From - To)</b> July 2019 - Jun 2020
--	--	---

<b>4. TITLE AND SUBTITLE</b> A Model to Analyze the Capacity of Pilot Training Production	<b>5a. CONTRACT NUMBER</b>
	<b>5b. GRANT NUMBER</b>
	<b>5c. PROGRAM ELEMENT NUMBER</b>

<b>6. AUTHOR(S)</b> Colbath, Derek J. Maj	<b>5d. PROJECT NUMBER</b>
	<b>5e. TASK NUMBER</b>
	<b>5f. WORK UNIT NUMBER</b>

<b>7. PERFORMING ORGANIZATION NAME(S) AND ADDRESS(ES)</b> Air Force Institute of Technology Graduate School of Engineering and Management (AFIT/EN) 2950 Hobson Way Wright-Patterson AFB OH 45433-7765	<b>8. PERFORMING ORGANIZATION REPORT NUMBER</b> AFIT-ENS-MS-20-J-027
--	---

<b>9. SPONSORING/MONITORING AGENCY NAME(S) AND ADDRESS(ES)</b> 19th AF/A3 Colonel Gary J. Eilers, Director of Operations, 19 AF/A3 555 E St E. Bldg 581 Joint Base SA-Randolph, TX 78150 gary.eilers@us.af.mil	<b>10. SPONSOR/MONITOR'S ACRONYM(S)</b>  19th AF/A3
	<b>11. SPONSOR/MONITOR'S REPORT NUMBER(S)</b>

**12. DISTRIBUTION/AVAILABILITY STATEMENT**  
Approved for Public Release

**13. SUPPLEMENTARY NOTES**  
This work is declared a work of the U.S. Government and is not subject to copyright protection in the United States

**14. ABSTRACT**  
A worldwide shortage for pilots combined with an increasing global demand for air transportation has left the United States Air Force 10% short of required pilot manning numbers. Air Education and Training Command (AETC) is working hard on the front line to increase training capacity; however, the complexity of the training process has made it difficult to smooth the flow. Review of literature on pilot production, organizational management, and queueing yielded the need to model the pilot production process to better understand the relationship between sub-programs. This model examines the variables of the training pipeline and helps determine some of the limiting factors that constrain capacity.

**15. SUBJECT TERMS**  
Capacity, Pilot Production, Operational Management, Queueing

<b>16. SECURITY CLASSIFICATION OF:</b>			<b>17. LIMITATION OF ABSTRACT</b>	<b>18. NUMBER OF PAGES</b>	<b>19a. NAME OF RESPONSIBLE PERSON</b>
<b>a. REPORT</b>	<b>b. ABSTRACT</b>	<b>c. THIS PAGE</b>			Dr. Alfred E. Thal AFIT/ENV
			UU	59	<b>19b. TELEPHONE NUMBER (Include area code)</b> (937) 255 - 3636 ext. 7401 al.thal@afit.edu