



DEPARTMENT OF THE NAVY

OFFICE OF COUNSEL
NAVAL UNDERSEA WARFARE CENTER DIVISION
1176 HOWELL STREET NEWPORT RI 02841-1708

IN REPLY REFER TO

Attorney Docket No. 113085
21 September 2020

The below identified patent application is available for licensing. Requests for information should be addressed to:

TECHNOLOGY PARTNERSHIP OFFICE
NAVAL UNDERSEA WARFARE CENTER
1176 HOWELL ST.
CODE 00T2, BLDG. 102T
NEWPORT, RI 02841

Serial Number 16/919,263
Filing Date 2 July 2020
Inventor Tariq Manzur

Address any questions concerning this matter to the Technology Partnership Office at (401) 832-3339.

DISTRIBUTION STATEMENT
Approved for Public Release
Distribution is unlimited

OPTICALLY BIASED PHOTONIC TRANSMITTER AND DETECTOR

STATEMENT OF GOVERNMENT INTEREST

[0001] The invention described herein may be manufactured and used by or for the Government of the United States of America for governmental purposes without the payment of any royalties thereon or therefor.

CROSS REFERENCE TO OTHER PATENT APPLICATIONS

[0002] This patent application is co-pending with two related patent applications entitled PHOTONIC TRANSMITTER WITH REMOTE POWER (Attorney Docket No. 113084), and ISOLATED PHOTONIC TRANSMITTER AND DETECTOR (Attorney Docket No. 300154), by same inventor as this application.

BACKGROUND OF THE INVENTION

(1) Field of the Invention

[0003] The present invention is directed to a photonic transmitter having a bias control that is buffered from local power fluctuations.

(2) Description of the Prior Art

[0004] A radio frequency (RF) photonic link is used for connecting a radio or radar signal from an antenna to a remote location. FIG. 1 shows a typical prior art RF photonic link. A

link transmitter 10 receives an RF signal 12 at a low noise amplifier (LNA) 14. LNA 14 is joined to provide the amplified RF signal to an optical intensity modulator 16. Modulator 16 receives light from a signal laser 18 and uses the amplified RF signal to modulate the light into an intensity modulated optical signal. Intensity modulated optical signal is provided over optical fiber 20 to a link receiver 22.

[0005] Modulator 16 utilizes a Mach Zehnder interferometer having a splitter 24 that splits light from signal laser 18 to a first optical path 26 and a second optical path 28. An electrical field applied to one or both paths at a modulating electrode 30 and a ground electrode 32 introduces a differential phase change in optical signals in the paths. Ground electrodes are joined to ground 34. These optical signals having a differential phase interfere when first optical path 26 is combined with second optical path 28 such as at coupler 36. The signal voltage that causes a 180° phase shift results in destructive interference. This voltage is identified as V_π .

[0006] In common operation of modulator 16, a bias source 38 provides a bias voltage $V_{\pi,DC}$ at bias electrode 40. Bias voltage $V_{\pi,DC}$ is typically set at the quadrature bias or $V_{\pi/2}$ in order to optimize photonic link characteristics. Variations in RF signal input may make it desirable to change the bias voltage.

[0007] A remote direct current power supply is required for powering LNA 14 and bias source 34. The power supply is often shared between various electronic components located proximate to RF input 12. This configuration is prone to ground loop problems and electro-magnetic interference. In addition, optical intensity modulator 10 is known to suffer from bias drifting caused by environmental perturbations, such as temperature, pressure, and humidity. For optimum operation, the modulator bias voltage should be adjusted in real time; however, placing a bias source with sophisticated bias control logic digital circuitry within the RF photonic link increases its size, cost and complexity.

SUMMARY OF THE INVENTION

[0008] It is an object of the invention is to provide a photonic transmitter having remotely controlled bias.

[0009] Accordingly, there is provided an optically biased photonic link that receives a radio frequency (RF) signal and includes a signal laser joined to an optical intensity modulator. A low noise amplifier receives the RF signal and provides an amplified signal to the modulator. The modulator converts the signal into an optical signal. The optical signal is received by a link receiver which provides an analysis signal and an output signal. A bias logic circuit uses the analysis

signal to provide an optical bias signal to an optical detector joined to modulator. The optical detector provides a responsive bias voltage to the modulator. The optical detector can provide a positive bias control signal or a negative bias control signal.

BRIEF DESCRIPTION OF THE DRAWINGS

[0010] Reference is made to the accompanying drawings in which are shown an illustrative embodiment of the invention, wherein corresponding reference characters indicate corresponding parts, and wherein:

[0011] FIG. 1 is a diagram of a prior art photonic transmitter.

[0012] FIG. 2 is a diagram of a first embodiment of a photonic transmitter having remote power and bias control.

[0013] FIG. 3 is a diagram of a second embodiment of a photonic transmitter having remote power and bias control.

[0014] FIG. 4 is a diagram of a third embodiment of a photonic transmitter having remote power and local bias control.

[0015] FIG. 5 is a diagram of a fourth embodiment of a photonic transmitter having local power and remote bias control.

DETAILED DESCRIPTION OF THE INVENTION

[0016] FIG. 2 shows an embodiment of an electrically isolated RF photonic link. This embodiment utilizes remote electrical

energy delivery and remote modulator bias control. Link transmitter 50 receives an RF signal 12 at LNA 14. As before, LNA 14 provides an amplified signal to optical intensity modulator 16. Signal laser 18 provides light to modulator 16 which provides an intensity modulated optical signal over optical fiber 20 to a link receiver/analyzer 52.

[0017] In modulator 16, light from signal laser 18 is split by splitter 24 into two paths 26 and 28. Signal from LNA 14 is provided to a modulating electrode 30 which cooperates with ground electrode 32 to generate an electric field. Electric field modifies the refractive index of either one or both paths 26 and 28 resulting in a relative phase change between paths 26 and 28. When optical signals on paths 26 and 28 are combined in coupler 36, the resulting optical signal is intensity modulated. The intensity modulated signal is provided on optical fiber 20.

[0018] Link transmitter 50 is electrically joined to a photovoltaic array 54 to avoid noise. Photovoltaic array 54 receives light from optical fiber power link 56 which is joined to a remotely located power laser 58. Thus, LNA 14 is electrically isolated from other electrical devices related to RF input 12. Ground loop and electromagnetic interference problems are thus avoided.

[0019] The bias source is also isolated from local electrical devices. A photodiode 60 is provided to receive an optical bias

control signal from optical fiber bias link 62. Optical fiber bias link is joined to a bias logic source 64 which includes an optical transmitter. Photodiode 60 converts optical energy from bias control signal into a bias voltage which is applied to bias electrode 40. Bias logic source 64 is joined to link receiver and analyzer 52 to receive information about the condition of the intensity modulated optical signal such as the optical power and nonlinearities. Remote placement of modulator bias logic simplifies link transmitter 50 and allows feedback to compensate for environmental and signal factors affecting the optical link. Resistor 66 is used to provide a base level of bias voltage from photovoltaic array 54 to bias electrode 40.

[0020] In further detail, power laser 58 should have a power of about 10 w. The optical energy can be in any wavelength of convenience, including 0.8 micron, 1.0 micron, 1.5 micron and etc. Power laser 58 can be a semiconductor laser, fiber laser, bulk solid state laser, or the like.

[0021] Photovoltaic array 54 is an array of photovoltaic cells for generating a constant DC voltage to provide power to LNA 14. Photovoltaic array 54 cathode serves as the ground for modulator 16 and other circuitry. Photovoltaic array 54 preferably utilizes GaAs or InGaAsP/InP technologies that enable highly efficient optical-to-electric DC power conversion. The photovoltaic cells making up array 54 can utilize PIN device

configuration for maximizing efficiency. Twenty photovoltaic cells in array 54, each having an active area of 1 mm² can generate a 4 volt DC voltage and > 2A current. Photovoltaic array 54 is preferably integrated with modulator 16 by flip-chip bonding.

[0022] FIG. 2 shows an active bias control signal in which a base level of bias voltage is powered by photovoltaic array 54. Additional bias voltage is provided by photodiode 60 in response to optical bias control signal. A InGaAsP/InP PIN photodetector is preferred as photodiode 60 for controlling the modulator bias voltage. The modulator bias voltage is thus adjusted in real-time to assure an optimum modulator bias condition. The bias voltage circuitry is also integrated on chip with modulator 16 and other RF photonic transmitter components using flip-chip bonding.

[0023] FIG. 3 shows an alternate embodiment 50' of the link transmitter. This embodiment utilizes a photoresistor 68 in place of photodiode 60 and resistor 66. Photoresistor 68 has a base level of resistance that can be used for providing a basic level of bias to modulator 16. Additional bias voltage can be provided by increasing the optical bias control signal from bias logic source 64'. This reduces the resistance in photoresistor 68. Instead of relying on power from photodiode 60 as in FIG.

2, all of the bias voltage in this embodiment originates from photovoltaic array 54.

[0024] FIG. 4 shows an additional alternate embodiment 50'' that utilizes external power for LNA 14 and internal bias logic 70. Internal bias logic 70 is directly powered by photovoltaic array 54. As in previous embodiments, photovoltaic array 54 is powered by optical fiber power link 56 joined to power laser 58. Internal bias logic 70 utilizes internal linkages and conditions to provide a bias voltage from photovoltaic array 54. Bias logic 70 can be joined to LNA 14 for analysis of RF signal conditions. The embodiment shown in FIG. 4 simplifies the external connections by not utilizing the optical bias control signal utilized in other embodiments.

[0025] FIG. 5 shows yet another alternate embodiment 50''' in which the bias control signal is provided externally while the LNA 14 is powered from sources at the remote location. As in FIG. 2 and 3, above, a bias control signal on optical fiber bias link 62 is provided by bias logic 64. A photodetector 72 is joined to receive the bias control signal from the optical fiber bias link 62. Photodetector 72 can be a photodiode that provides its own power from the bias control signal as in FIG. 2, or it can be a photoresistor as in FIG. 3 that changes resistance in response to the bias control signal. In the latter case, bias voltage would need to originate from a power

source 74 at the remote location. Power source 74 can also be used to supplement bias voltage provided by the photodiode embodiment.

[0026] Preserving efficient signal communication among the components and reducing insertion losses is a goal of this invention. Monolithic integration may be possible if the intensity modulator is made of III-V semiconductor materials. Flip-chip bonding can also be used for component integration., monolithic integration is also possible.

[0027] It will be understood that many additional changes in the details, materials, steps and arrangement of parts, which have been herein described and illustrated in order to explain the nature of the invention, may be made by those skilled in the art within the principle and scope of the invention as expressed in the appended claims.

[0028] The foregoing description of the preferred embodiments of the invention has been presented for purposes of illustration and description only. It is not intended to be exhaustive, nor to limit the invention to the precise form disclosed; and obviously, many modification and variations are possible in light of the above teaching. Such modifications and variations that may be apparent to a person skilled in the art are intended to be included within the scope of this invention as defined by the accompanying claims.

OPTICALLY BIASED PHOTONIC TRANSMITTER AND DETECTOR

ABSTRACT OF THE DISCLOSURE

An optically biased photonic link receives a radio frequency (RF) signal and includes a signal laser joined to an optical intensity modulator. A low noise amplifier receives the RF signal and provides an amplified signal to the modulator. The modulator converts the signal into an optical signal. The optical signal is received by a link receiver which provides an analysis signal and an output signal. A bias logic circuit uses the analysis signal to provide an optical bias signal to an optical detector joined to modulator. The optical detector provides a responsive bias voltage to the modulator. The optical detector can provide a positive bias control signal or a negative bias control signal.

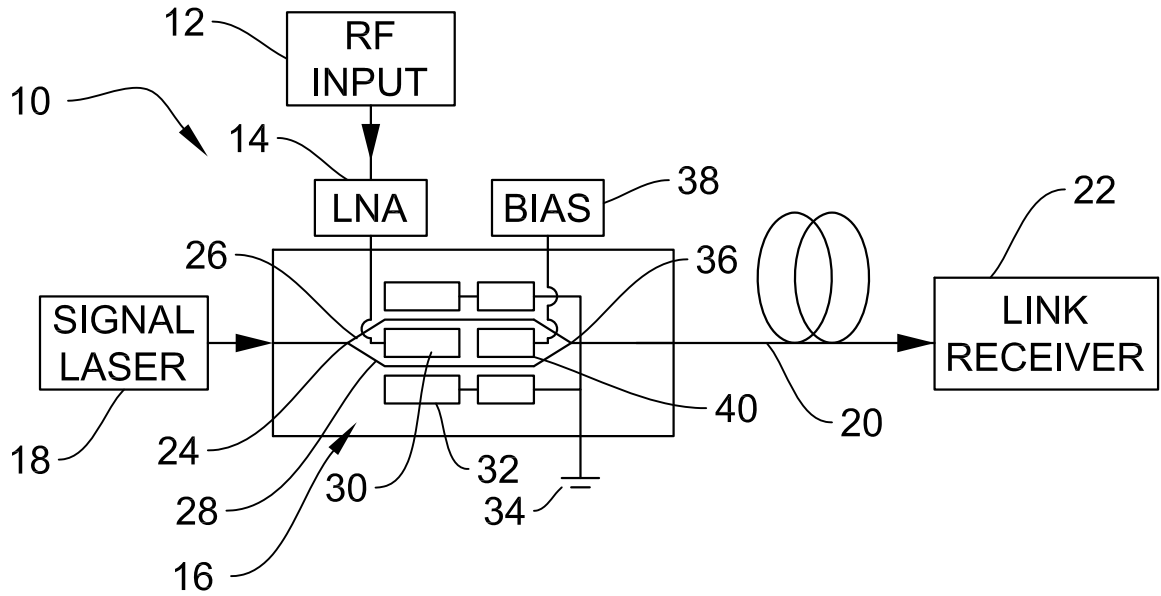

FIG. 1
(PRIOR ART)

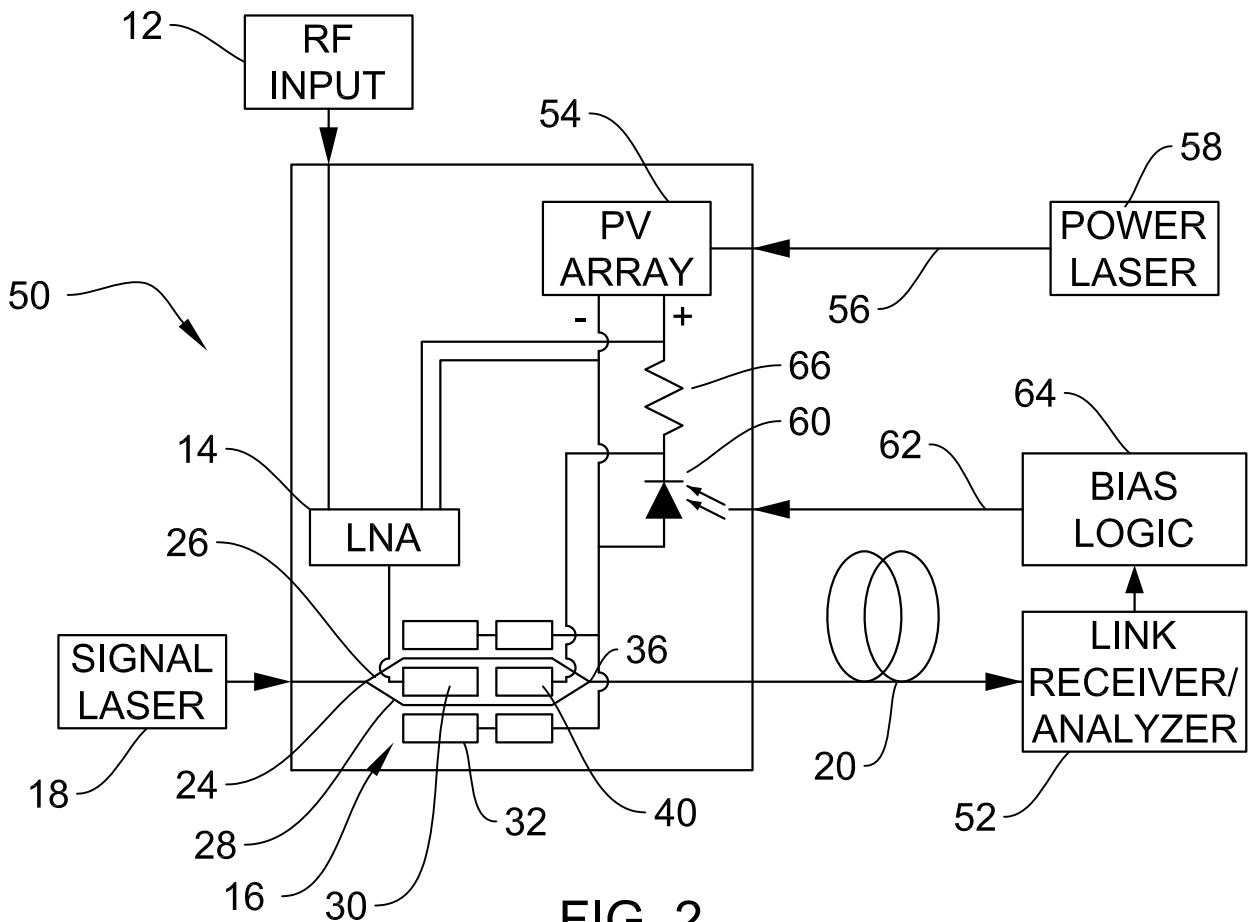

FIG. 2

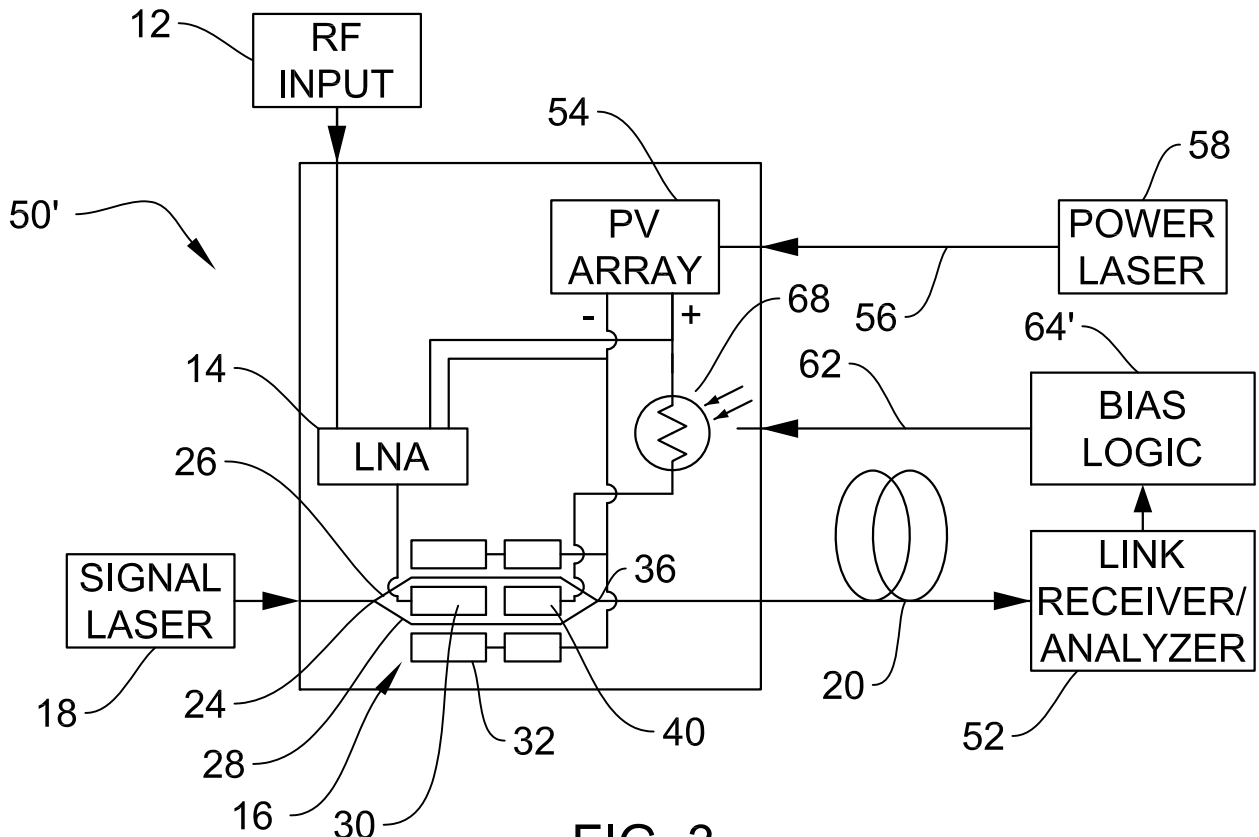

FIG. 3

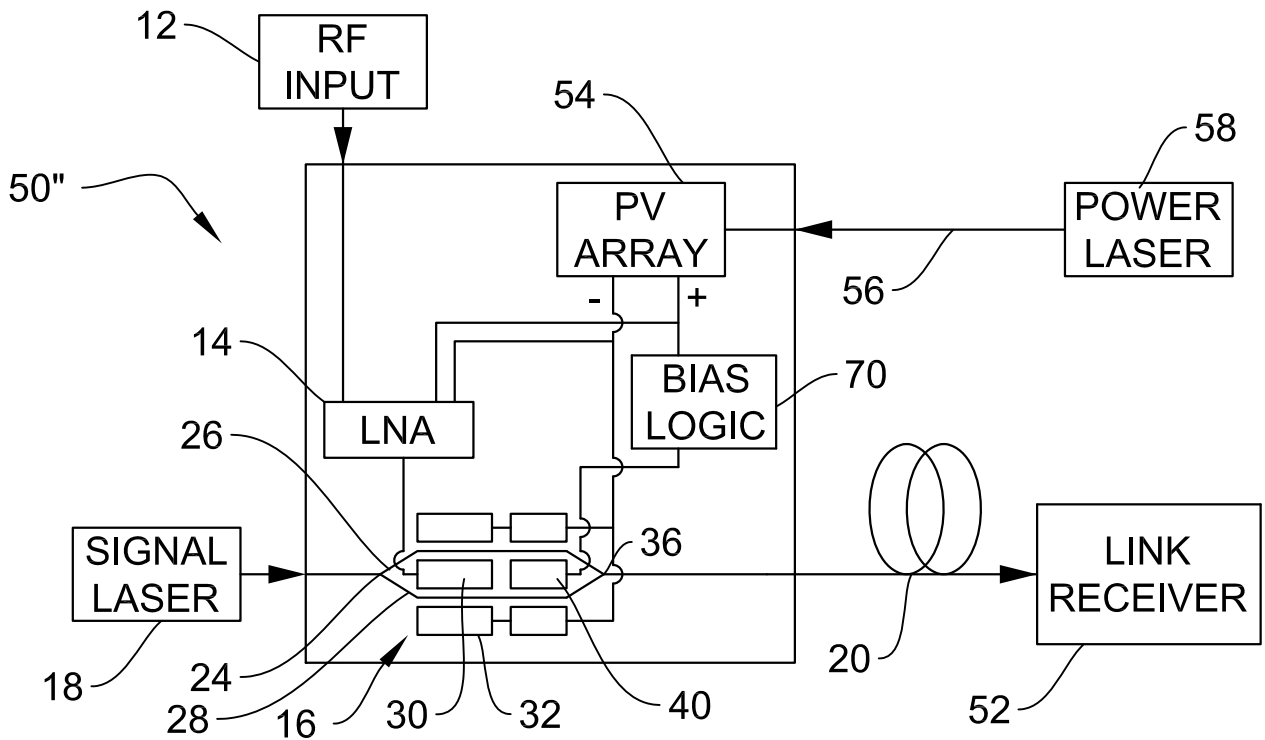

FIG. 4

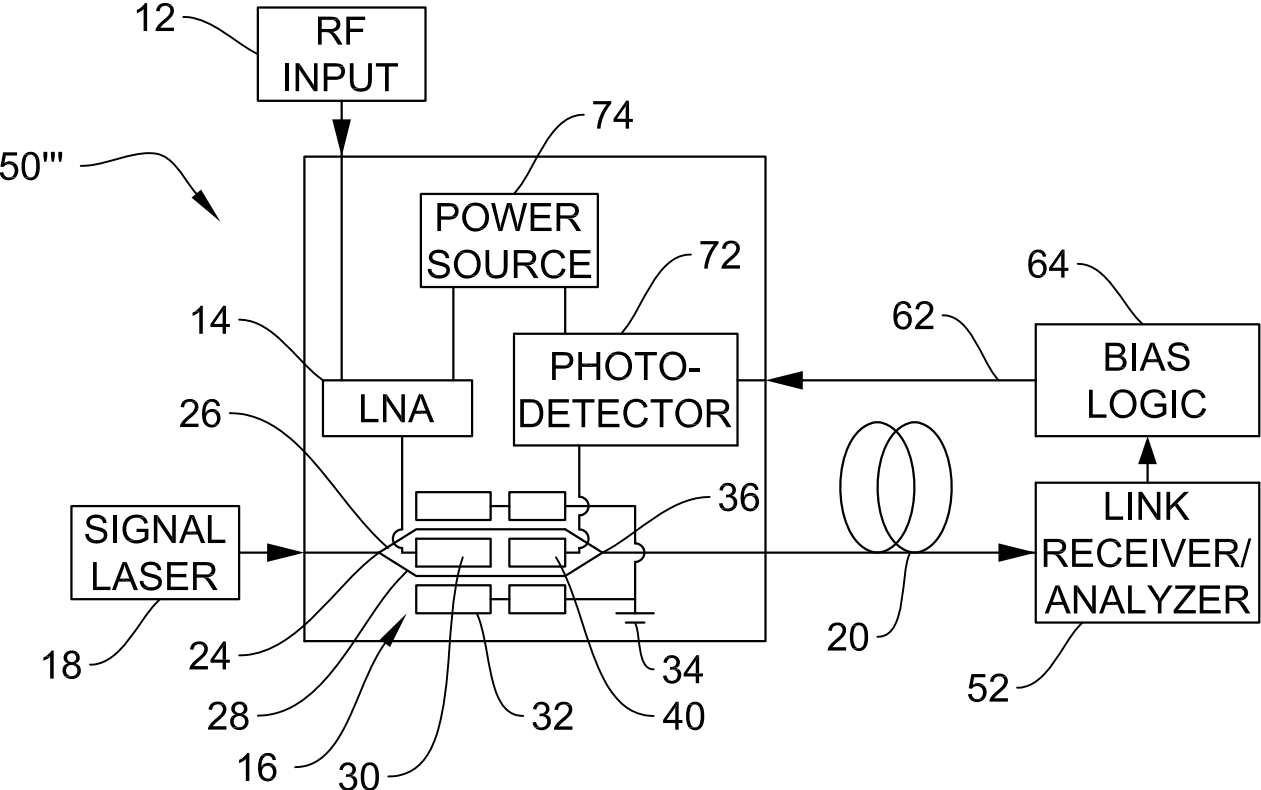

FIG. 5