



DEPARTMENT OF THE NAVY

OFFICE OF COUNSEL
NAVAL UNDERSEA WARFARE CENTER DIVISION
1176 HOWELL STREET NEWPORT RI 02841-1708

IN REPLY REFER TO

Attorney Docket No. 300006
21 September 2020

The below identified patent application is available for licensing. Requests for information should be addressed to:

TECHNOLOGY PARTNERSHIP OFFICE
NAVAL UNDERSEA WARFARE CENTER
1176 HOWELL ST.
CODE 00T2, BLDG. 102T
NEWPORT, RI 02841

Serial Number 16/784,280
Filing Date 7 February 2020
Inventor Thomas J. Gieseke

Address any questions concerning this matter to the Technology Partnership Office at (401) 832-3339.

DISTRIBUTION STATEMENT
Approved for Public Release
Distribution is unlimited

LAUNCH SPEED MULTIPLIER

STATEMENT OF GOVERNMENT INTEREST

[0001] The invention described herein may be manufactured and used by or for the Government of the United States of America for governmental purposes without the payment of any royalties thereon or therefor.

CROSS REFERENCE TO OTHER PATENT APPLICATIONS

[0002] None.

BACKGROUND OF THE INVENTION

(1) Field of the Invention

[0003] The present invention relates to a gas propelled mechanical launcher.

(2) Description of the Prior Art

[0004] There is an ongoing need for the development of high-speed vehicles for a range of applications. As such, launchers are required to accelerate those vehicles from rest to a high velocity. One type of launcher system for the launch of small devices is a gas propelled canister launcher. Canister launchers are well known in the art.

[0005] The basic construction of a gas propelled launcher is a tube divided into two sections by a piston, also referred to

as a pusher plate. On one side of the pusher plate is the launch vehicle in a launcher volume and on the other side of the pusher plate is a void or breech chamber that can be rapidly filled with compressed air (from a reservoir or gas generator). The expansion of the compressed air is capable of forcing the pusher plate to launch the vehicle out of the launcher.

[0006] The rate of gas release into the volume behind the pusher plate is designed to maximize the transfer of energy to the launch vehicle while controlling the acceleration of the launch vehicle. Gas propelled canister launchers are designed for a specific mass vehicle and acceleration profile.

08If there is a need to launch a lighter vehicle from the same launcher (at a higher exit velocity), and the original launch vehicle is replaced with a light weight vehicle; the system performance will be poor. The poor performance is because the light weight vehicle will be accelerated rapidly and the flow of gas into the volume behind the pusher plate will be incomplete. Unless the gas supply system is redesigned; the launcher will perform sub-optimally.

[0007] A solution to adapt to varying launch vehicles would be to modify an existing launcher system with an adapter assembly or mechanism that increases launch exit velocity while maintaining the pusher plate design acceleration profile and

without altering the gas supply dynamics. Provided that the total assembly (the adapter assembly plus the launch vehicle) is lighter than the standard heavier payload; the exit velocity can be increased to take advantage of the available launch energy.

[0008] Based on the state of the prior art, an improved apparatus is needed that can be used to modify a gas generator canister launcher so that light weight vehicles can be launched at high velocity from the launcher without requiring the redesign of the gas generator system.

SUMMARY

[0009] It is therefore a primary object and general purpose of the present invention to provide an adapter apparatus for launching a stationary launch vehicle or projectile from rest to a prescribed exit velocity.

[0010] It is a still further object of the present invention to provide an adapter apparatus for imparting a linear velocity to a launch vehicle or projectile that exceeds the linear velocity of a pusher plate of a launcher.

[0011] To attain the objects of the present invention, an adapter assembly for a compressed gas launcher is provided for use with high-speed projectiles or launch vehicles. The

inventive adapter assembly allows forces applied to the pusher plate to be transferred to the launch vehicle.

[0012] The adapter assembly includes rollers that engage an inner surface of the cylindrical launcher and the outer surface of the launch vehicle. With the adapter assembly, the effective mass of the launch assembly, as experienced by the pusher plate, can remain constant while the exit velocity of a replacement lighter weight vehicle is increased.

[0013] The adapter cage of the assembly comprises three or more rails, connected by two circumferential frames, positioned in the annulus between the outer surface of the launch vehicle and the inner diameter of the launch tube. A first circumferential frame connected to an end of each of these rails is in contact with the pusher plate. An array of wheels are attached to the rails, spaced uniformly along the length of each rail, with rotational axes aligned with the circumference of the annular region. The wheels along each rail are linked together with coupling rods.

[0014] The launch vehicle would be positioned in the center of the adapter cage. A muzzle closure cap covers the end of the launch tube and is held in place with sheer pins. Seals are also in place to prevent the low of water from outside of the launch tube into the launcher volume.

[0015] To launch the launch vehicle, compressed air is released into the breech chamber from a compressed air canister or tank. Forces on the pusher plate are transferred through the adapter cage and onto the muzzle closure cap. Because the adapter cage wheels are in contact with the inner surface of the launch tube; frictional forces cause the wheels to rotate. The wheels are also positioned to be in contact with the outer surface of the launch vehicle. The wheel rotation transfers forces to the launch vehicle and causes the launch vehicle to move longitudinally toward the muzzle closure cap. When the pusher plate moves toward the end of the launch tube, the launch vehicle will reach the end of the adapter assembly which then forces out the muzzle cap. When the movement force exceeds the failure strength of the sheer pins; the pins fail and the pusher plate moves longitudinally. The launch vehicle then exits the launcher and continues under power.

[0016] Because the velocity of the outer surface of the wheels is zero at a no-slip condition on the inner surface of the launch tube and the hub velocity of the wheels is equal to the pusher plate and cage velocity; the inner surface of the wheels at the surface of the launch vehicle will be twice the velocity of the pusher plate and cage velocity. Similarly, the net force exerted on the launch vehicle will be one half of the net force exerted by the pusher plate on the adapter cage.

BRIEF DESCRIPTION OF THE DRAWINGS

[0017] Other objects, features and advantages of the present invention will become apparent upon reference to the following description of the preferred embodiments and to the drawings, wherein corresponding reference characters indicate corresponding parts throughout the several views of the drawings and wherein:

[0018] **FIG. 1** depicts a cross-section of the adapter assembly of the present invention viewed with the launcher system;

[0019] **FIG. 2** depicts a perspective view of the adapter of the present invention;

[0020] **FIG. 3** depicts the launcher system in a first phase of projectile loading;

[0021] **FIG. 5** depicts the launcher system in an intermediate phase of projectile loading when the projectile is at a maximum longitudinal extent of engagement with the adapter assembly;

[0022] **FIG. 6** depicts the launcher system in an intermediate phase of projectile loading with a muzzle cap of the launch system shown; and

[0023] **FIG. 7** depicts the launcher system in a final phase of projectile loading and first phase of projectile launch when the projectile is at rest and in a pre-launch position.

DETAILED DESCRIPTION OF THE INVENTION

[0024] Systems and techniques exist for launching a projectile from rest. The present invention fits into this general category of device but employs a novel set and arrangement of components. These components allow the projectile to be accelerated to a higher velocity.

[0025] Referring now to the figures, **FIG. 1** depicts a launcher system **10** of the present invention viewed along the side of a launch vehicle **100**. A launch tube **12** of the launcher system **10** is divided into two sections. A first section is the breech chamber **14** which is fed by an air line **16** connected via a servo valve **18** to an air supply tank **20**. A second section is the launch tube volume **22**. The breech chamber **14** and the launch tube volume **22** are separated by a pusher plate **24**. The pusher plate **24** includes a seal **26** around a circumference in which the seal isolates the breech chamber **14** from the launch tube volume **22**.

[0026] A muzzle closure cap **30** is fitted into the open end of the launch tube **12**. A seal **32** on the muzzle closure cap **30** isolates the launch tube volume **22** from the environment **200**. Multiple shear pins **34** are distributed around the circumference of the launch tube **12** between the muzzle closure cap **30** and the launch tube **12**. The launch vehicle **100** can be centered in the launch tube volume **22**.

[0027] In use, an adapter cage assembly **70** is positioned in the annulus formed between an outer surface of the launch vehicle **100** and the launch tube **18**. The adapter cage assembly **70** comprises motion transfer wheels **74** with integral bearings **76**, motion transfer wheel axles **78**, linkage bars **80**, linkage bar pins **82** and an adapter cage **90**. A first end surface of the adapter cage **90** rests on the pusher plate **24** and a second end surface presses against the muzzle closure cap **30**.

[0028] **FIG. 2** shows details of the adapter cage **90**. The adapter cage **90** comprises a first circumferential ring **91** as the first end surface, multiple longitudinal rails **92**, and a second circumferential ring **94** as the second end surface. The first circumferential ring **91** and the second circumferential ring **94** lie in planes parallel to each other and are centered on a central axis of the launch vehicle **100**. The longitudinal rails **92** include axle mounting holes **94**.

[0029] Returning to **FIG. 1**, a plurality of the motion transfer wheels **74** are attached to the longitudinal rails **92** of the adapter cage **90** through mounting holes **96** (shown in **FIG. 2**) by the motion transfer wheel axles **78**. The motion transfer wheels **78** include the integral bearings **76**.

[0030] The linkage bar **80** connects the transfer wheels **74** which are attached to a common longitudinal rail **92**. Each longitudinal rail **92** has an associated linkage bar **80** with the

linkage bar connecting the motion transfer wheels **74** by the linkage bar pins **82** associated with a common longitudinal rail so that the motion transfer wheels attached to the common rail rotate in tandem.

[0031] To load the launch vehicle **100** into the launcher system **10**, the pusher plate **24** is first pressed into the muzzle end of the launch tube **12** as depicted in **FIG. 3**. The adapter cage assembly **70** is then positioned for loading as depicted in **FIG. 4**. The first circumferential ring **91** of the adapter cage **90** is positioned in contact with the pusher plate **24** (the surface facing the launch vehicle volume) such that the first set of motion transfer wheels **74** contacts the inner surface of the launch tube **12**.

[0032] The width of the adapter cage assembly **70** (adapter cage **90** with the motion transfer wheels **74** attached) is slightly larger than the inner diameter of the launch tube **12**. The motion transfer wheels **74** are slightly compressed during the insertion of the adapter cage assembly **70** into the launch tube **12** to produce frictional forces between the motion transfer wheels and the inner diameter of the launch tube. To allow this compression, the motion transfer wheels **74** are manufactured from a compressible material such as polyurethane.

[0033] As depicted in **FIG. 5**, the launch vehicle **100** is loaded into the adapter cage assembly **70** by feeding the launch

vehicle axially (launch vehicle tail **102** first) into the center of the adapter cage assembly **70** between the motion transfer wheels **74**. The total width of the space inside of the adapter cage assembly **70**, between the motion transfer wheels **74**, is slightly smaller than the outer diameter of the launch vehicle **100**.

[0034] As the launch vehicle **100** is pressed into the adapter cage assembly **70**; the launch vehicle engages the motion transfer wheels **74**. When the launch vehicle **100** engages the motion transfer wheels **74**; the motion transfer wheels are slightly compressed to produce large frictional forces between the motion transfer wheels and the outer diameter of the launch vehicle.

[0035] As depicted in **FIG. 6**, as the launch vehicle **100** is inserted further into the adapter cage assembly **70**, the adapter cage assembly and pusher plate **24** are forced into the launch tube **12** toward the breech chamber **14** through the action of the linked motion transfer wheels **74** and their engagement with the launch tube.

[0036] When the launch vehicle **100** and adapter cage assembly **70** are fully retracted into the launch tube **12**, as depicted in **FIG. 7**, the muzzle closure cap **30** is pressed into the open end of the launch tube and the shear pins **34** are inserted through the launch tube to secure the muzzle closure cap in place.

[0037] The launch process is initiated by opening the servo valve **18** to allow compressed air to flow through the air line **16** from the air supply tank **20** into the breech chamber **14**. As pressure rises in the breech chamber **14**; force is transferred through the pusher plate **24** and the adapter cage **90** to the muzzle closure cap **30**. When the force exceeds the failure strength of the shear pins **34** and the shear pins fail; the pusher plate **24** and adapter cage **90** then force the muzzle closure cap **30** off the end of the launch tube **12**.

[0038] Further expansion of gasses in the breech chamber **14** force the pusher plate **24** and adapter cage assembly **70** along the axis of the launch tube **12**, as depicted in **FIG. 6**. The motion transfer wheels **74** are in contact with the inner surface of the launch tube **12** during the launch process.

[0039] Frictional forces create a no slip condition at the contact point between the motion transfer wheels **74** and the inner surface of the launch tube **12**. As the adapter cage assembly **70** is forced longitudinally along with the central axis of the motion transfer wheels **74**; the motion transfer wheels and the outer surface of the launch vehicle **12** are forced longitudinally at twice the rate as the adapter cage assembly **70**. The launch vehicle **12** motion continues longitudinally until the launch vehicle is no longer in contact

with the motion transfer wheels **74** at which time the launch vehicle continues under power.

[0040] It will be understood that many additional changes in the details, materials, steps and arrangement of parts, which have been herein described and illustrated in order to explain the nature of the invention, may be made by those skilled in the art within the principle and scope of the expressed in the appended claims.

LAUNCH SPEED MULTIPLIER

ABSTRACT OF THE DISCLOSURE

An adapter cage is provided for a compressed gas launcher to multiply launch velocity. Kinematics of wheels integral to the adapter cage results in a doubling of the pusher plate velocity as that motion is imparted on a light-weight launch vehicle. The wheels of the adapter cage can press against the launch vehicle and the wheels are pressed against the walls of the launcher for employing friction at the interface of the wheels and the inner surface of the launcher to transfer motion to force out a muzzle cap of the launcher and to enable launch of the launch vehicle.

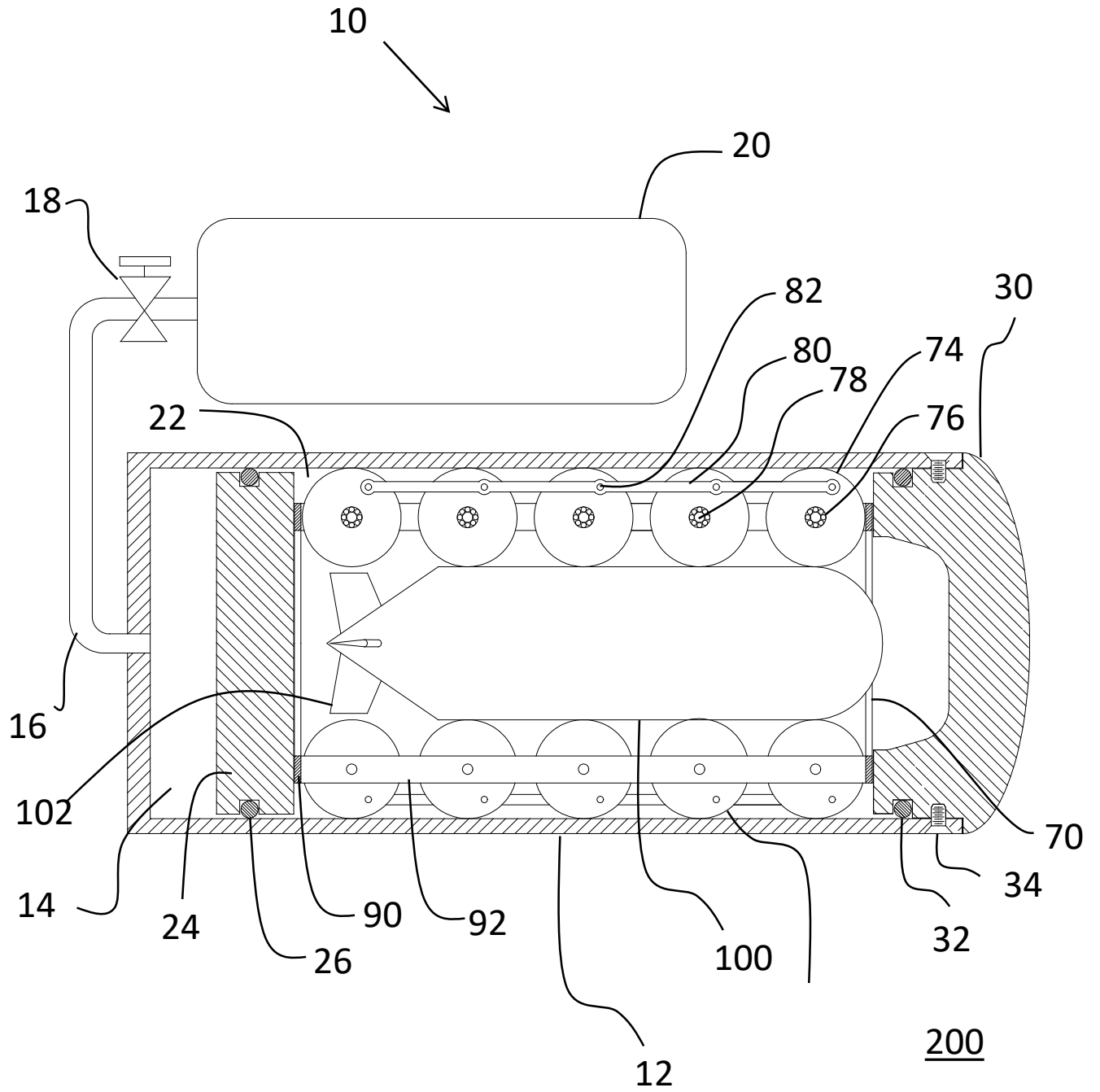

FIG. 1

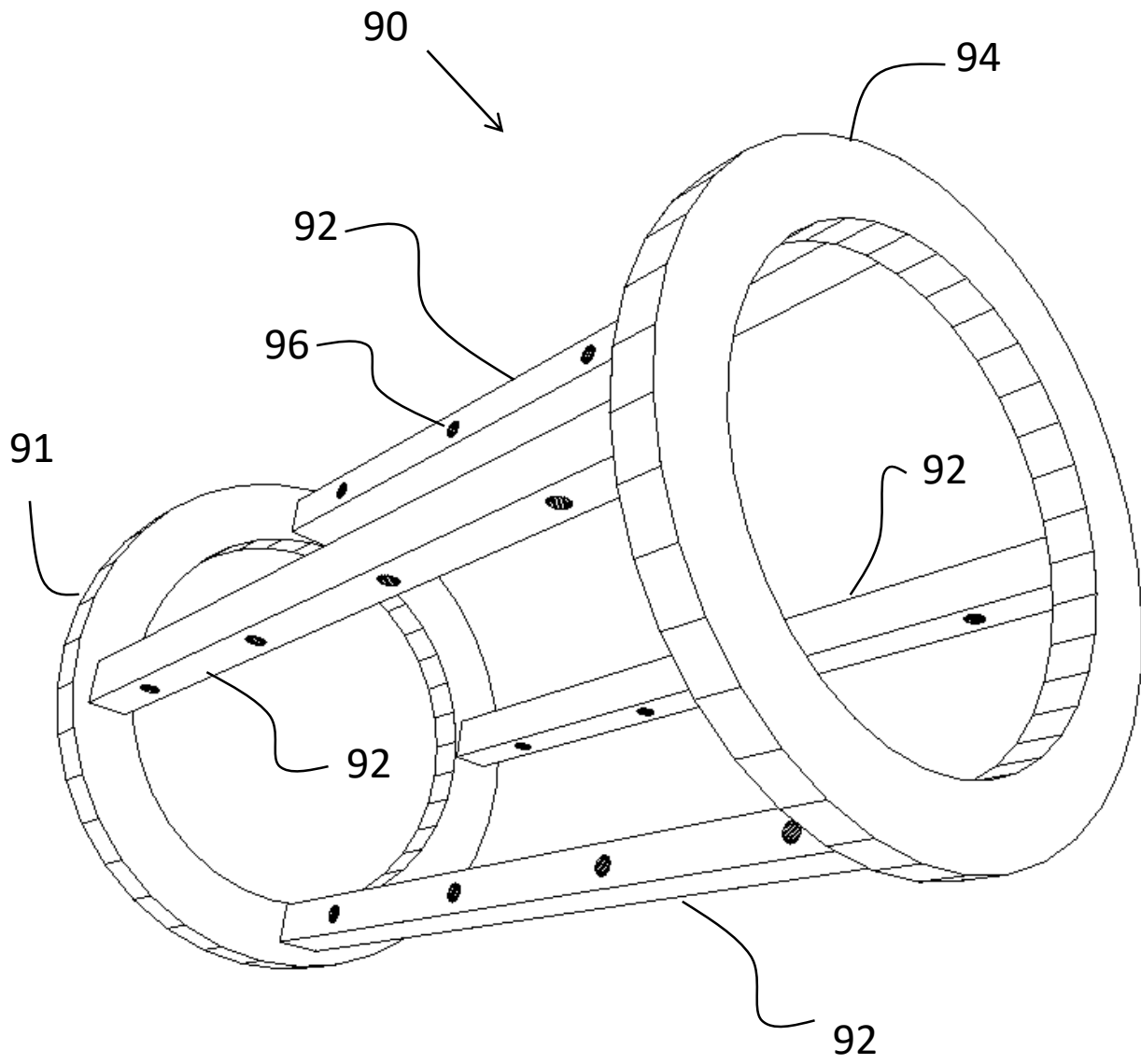

FIG. 2

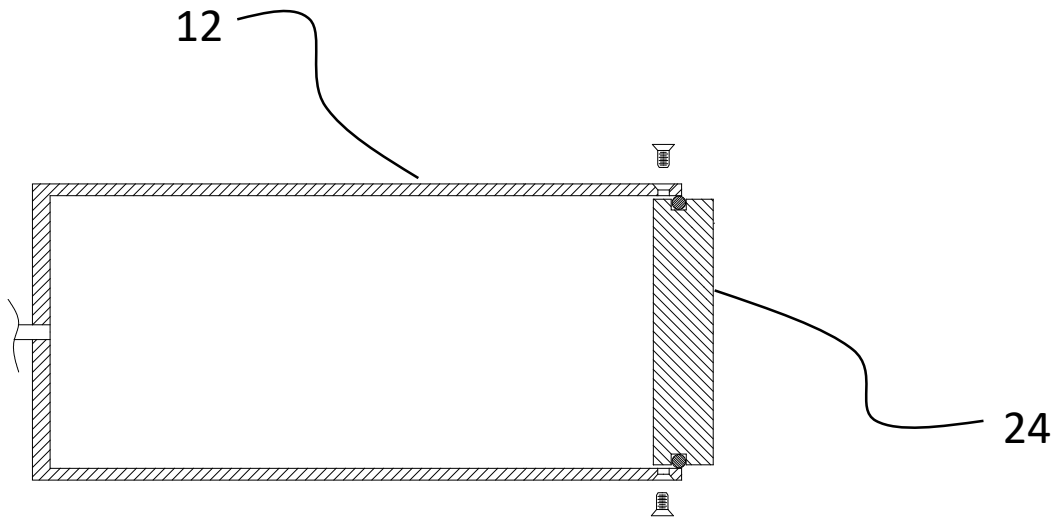

FIG. 3

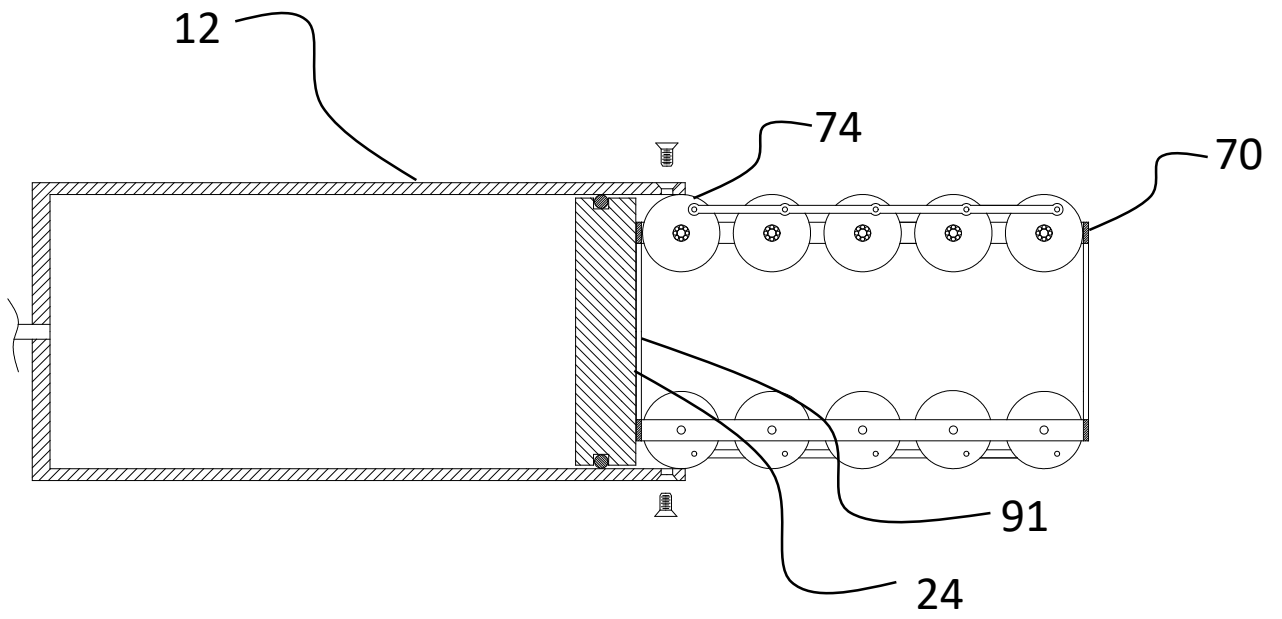

FIG. 4

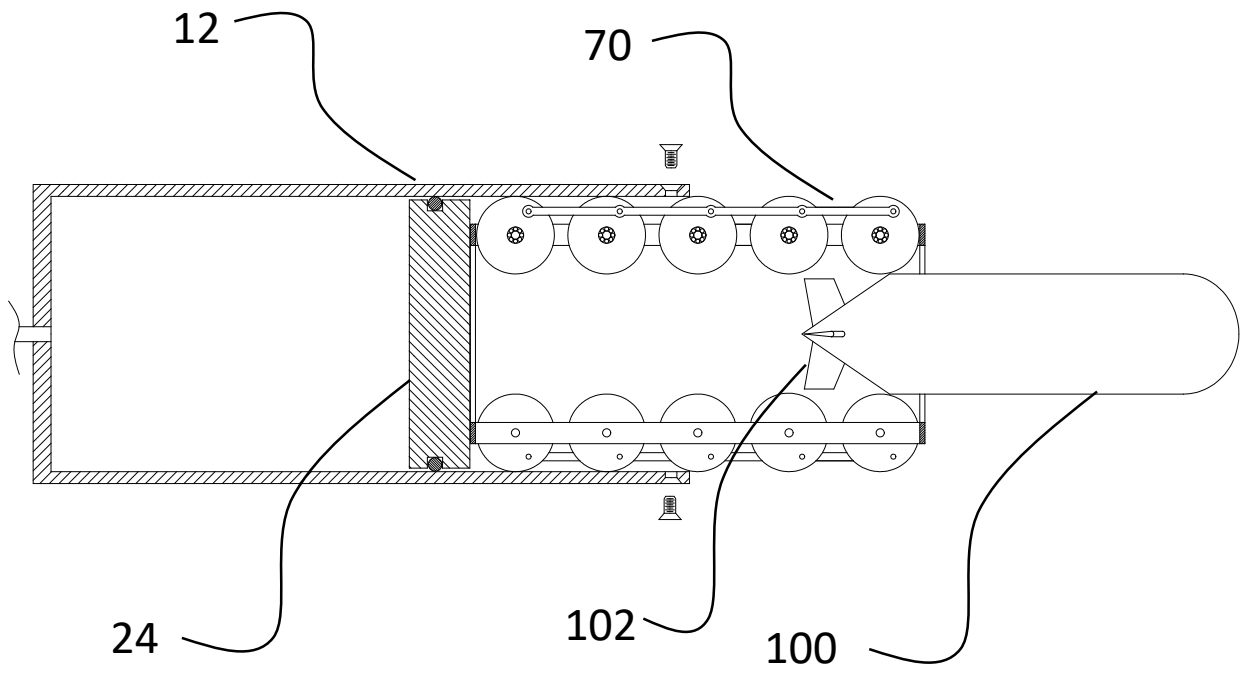

FIG. 5

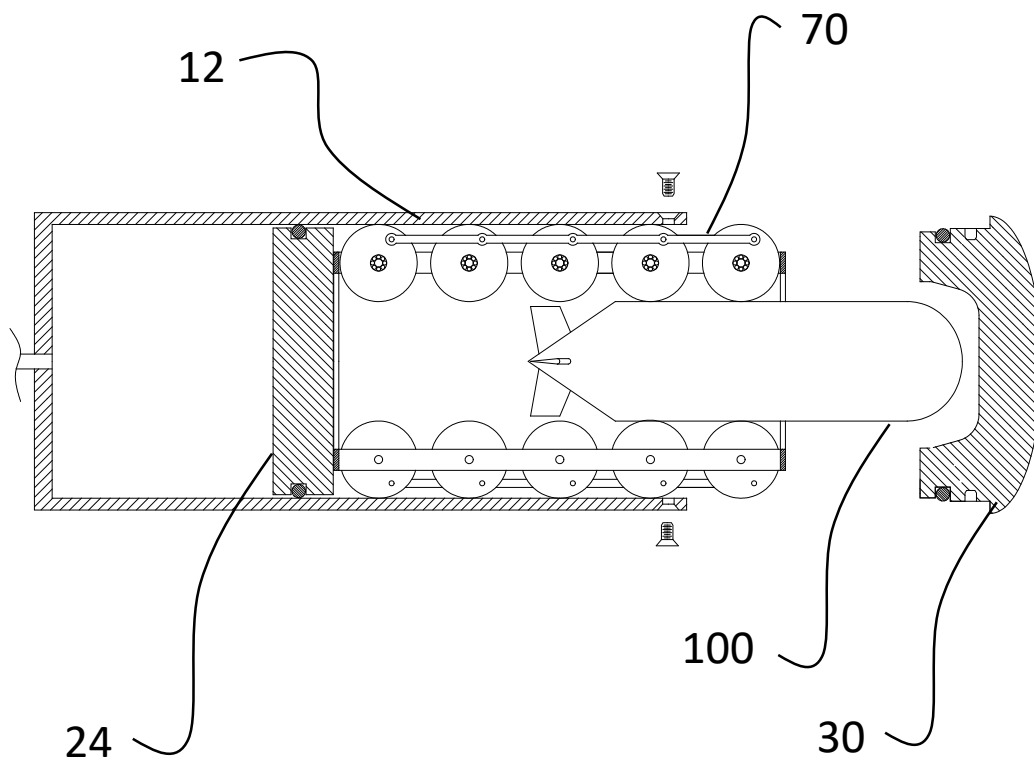

FIG. 6

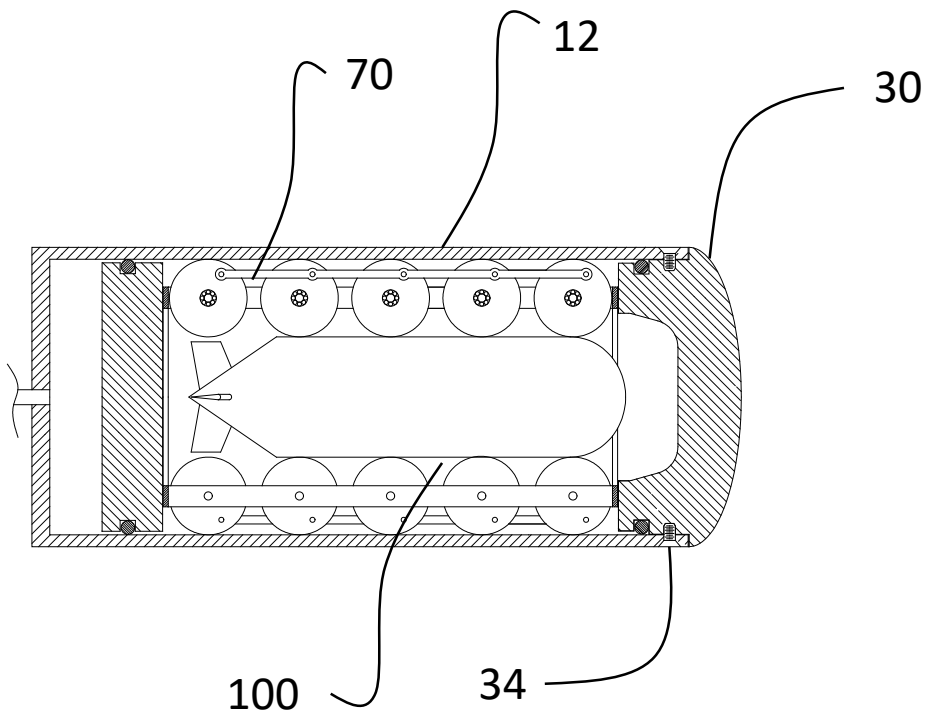

FIG. 7