

Carnegie Mellon University
Software Engineering Institute

RESEARCH REVIEW 2020

TwinOps – Digital Twins Meet
DevOps

Jerome Hugues

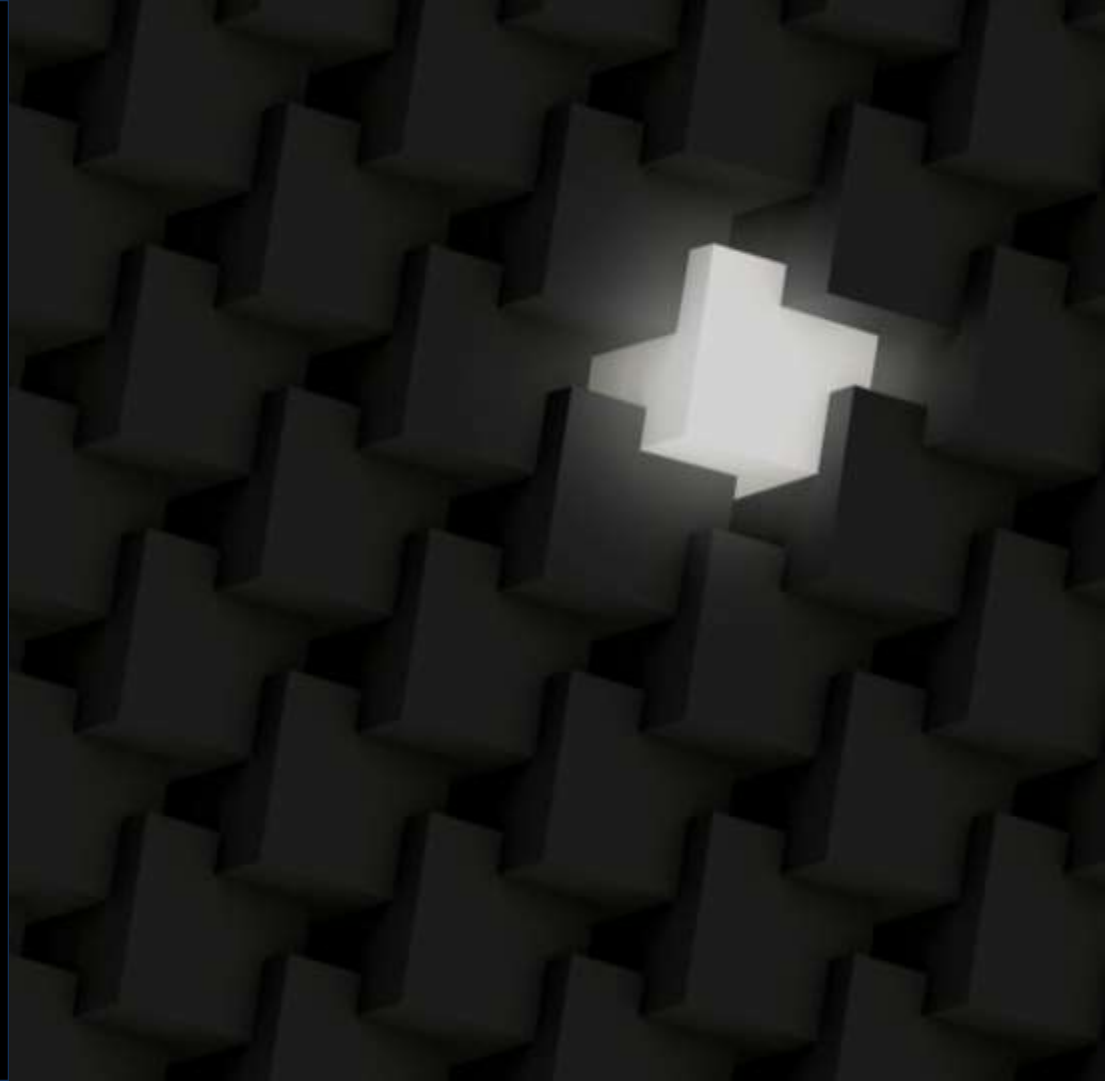

Copyright 2020 Carnegie Mellon University.

This material is based upon work funded and supported by the Department of Defense under Contract No. FA8702-15-D-0002 with Carnegie Mellon University for the operation of the Software Engineering Institute, a federally funded research and development center.

The view, opinions, and/or findings contained in this material are those of the author(s) and should not be construed as an official Government position, policy, or decision, unless designated by other documentation.

References herein to any specific commercial product, process, or service by trade name, trade mark, manufacturer, or otherwise, does not necessarily constitute or imply its endorsement, recommendation, or favoring by Carnegie Mellon University or its Software Engineering Institute.

NO WARRANTY. THIS CARNEGIE MELLON UNIVERSITY AND SOFTWARE ENGINEERING INSTITUTE MATERIAL IS FURNISHED ON AN "AS-IS" BASIS. CARNEGIE MELLON UNIVERSITY MAKES NO WARRANTIES OF ANY KIND, EITHER EXPRESSED OR IMPLIED, AS TO ANY MATTER INCLUDING, BUT NOT LIMITED TO, WARRANTY OF FITNESS FOR PURPOSE OR MERCHANTABILITY, EXCLUSIVITY, OR RESULTS OBTAINED FROM USE OF THE MATERIAL. CARNEGIE MELLON UNIVERSITY DOES NOT MAKE ANY WARRANTY OF ANY KIND WITH RESPECT TO FREEDOM FROM PATENT, TRADEMARK, OR COPYRIGHT INFRINGEMENT.

[DISTRIBUTION STATEMENT A] This material has been approved for public release and unlimited distribution. Please see Copyright notice for non-US Government use and distribution.

This material may be reproduced in its entirety, without modification, and freely distributed in written or electronic form without requesting formal permission. Permission is required for any other use. Requests for permission should be directed to the Software Engineering Institute at permission@sei.cmu.edu.

DM20-0855

Cyber-Physical Systems still exhibit misbehaviors after field tests. Their engineering relies on models built in isolation, limiting in-depth unit and integration testing until the system is done.

We are combining DevOps and Model-Based Engineering to build and deploy systems and their Digital Twins. TwinOps combines system, software, and physical models to improve system analysis.

Model-Based Engineering for DoD Cyber-Physical Systems



Create the best design that holds up over time as the system evolves.

+

Test the design without having to write any code.

=

Build a single model to assess hardware and embedded software before the system is built.

SAE AADL / ACVIP

- Standardized language and process for the engineering safety-critical systems.

OSATE

- Open Source AADL toolset for performing verification and validation (V&V).

DoD Transitioning

- Maturity increased through pilot projects and trainings.

TwinOps problem space: CPS Integration and Testing

High-Level Architecture

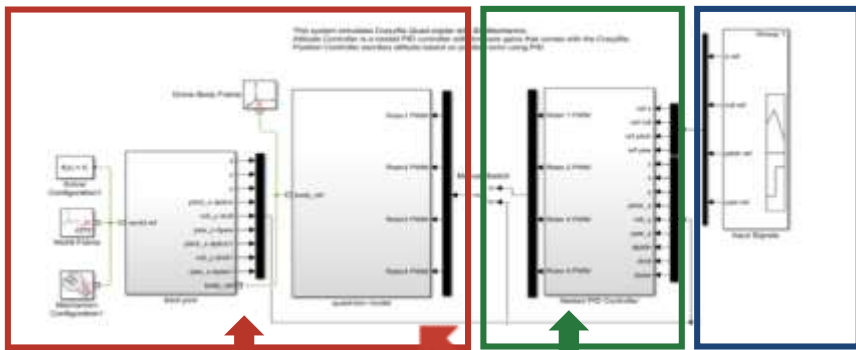

TwinOps: leverage other source of truth (e.g., CAD, Physics) to improve SW V&V
 ⇒ Use precise models instead of (naïve) abstractions for improved SW V&V
 ⇒ Combine domains, including SysEng

Implementation Space

SW/HW Architecture

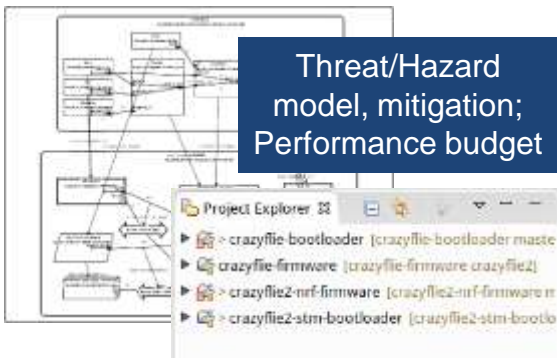
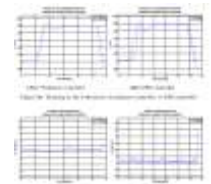

Mismatch, late discovery and rework

Actual sources

Models – an overview

Models are abstractions that address specific concerns.

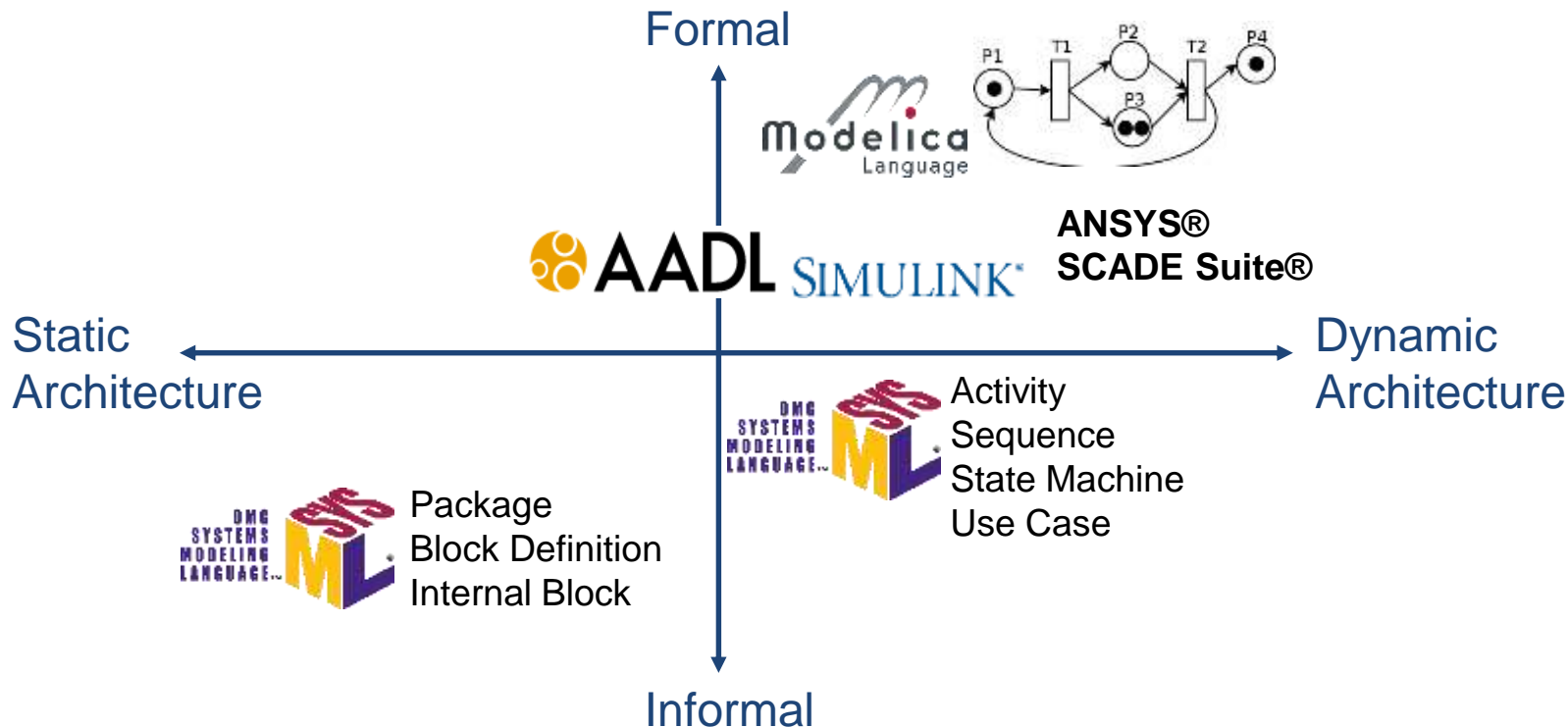

Technology Focus: Models and Code Generation

One can **generate code** from models ready to be embedded in the system (e.g., AADL to C) and get insights from the system to refine the model metrics.

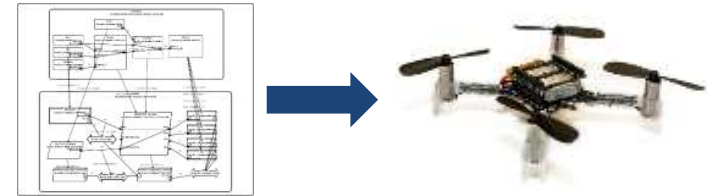

One can **simulate models** and generate simulation code as a mock-up of some system parts.

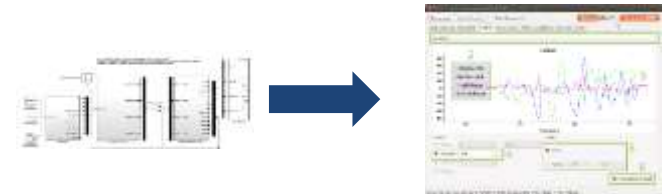

One can build **Digital Twins**, that compare actual system and its digital simulated doppelganger.

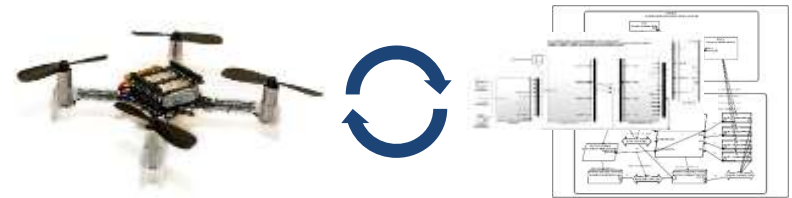

From DevOps to ModDevOps

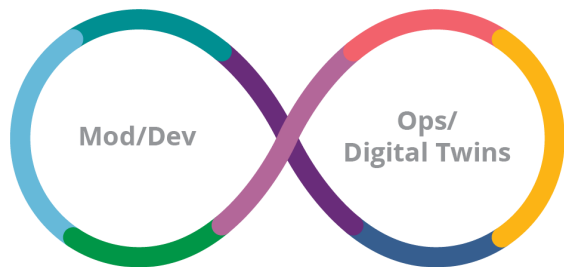

DevOps delivers software faster with increased quality:

- Continuous integration/deployment
- Containerized systems

DevOps is a software process, to be adapted to systems.

“ModDevOps is a systems/software co-engineering culture and practice that aims at unifying systems engineering (Mod), software development (Dev) and software operation (Ops). The main characteristic of the ModDevOps is to strongly advocate abstraction, automation, and monitoring at all steps of system construction.”

(adapted from <https://software.af.mil/training/devops/>)

ModDevOps in Action – Modeling Process

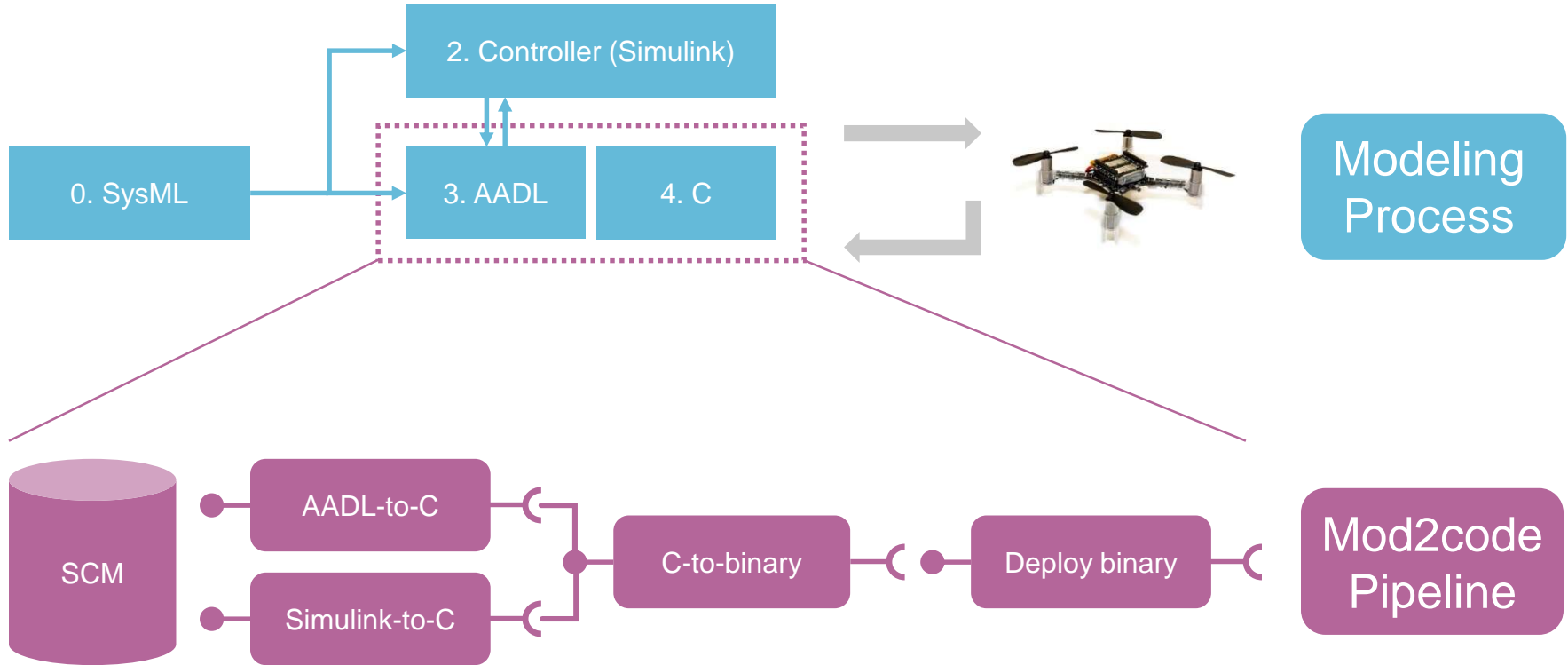

From ModDevOps to TwinOps

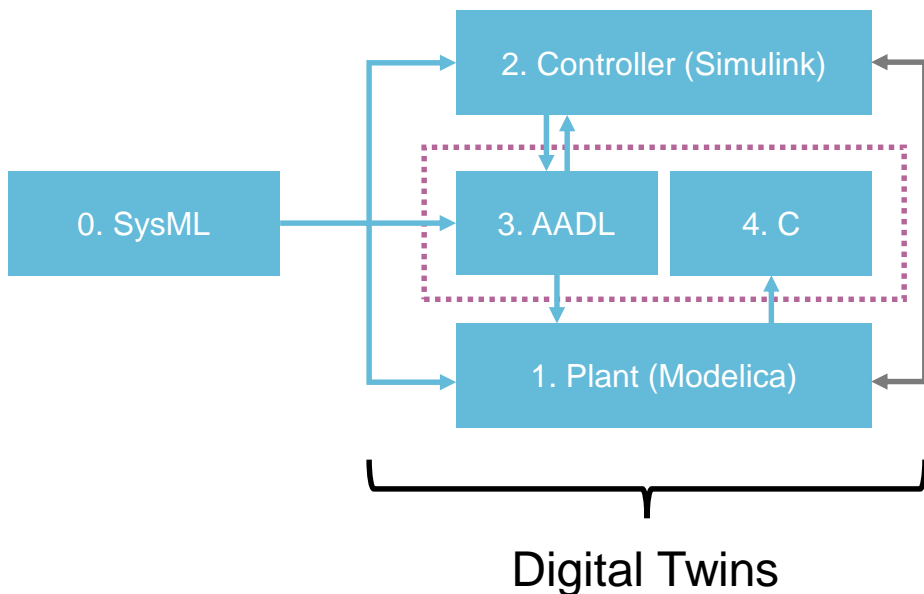

1-2-3-4: “mega-modeling” V&V

- 1-2: HLR validation
- 2-(3+4): validation of LLR
- 1+(3+4): virtual integration



Digital Twins of UAV vs. UAV flying: validation of Modelica model, efficiency of the controller (overshoot verification) and timing verification of software.

ModDevOps in Action – ModDevOps Pipeline #2

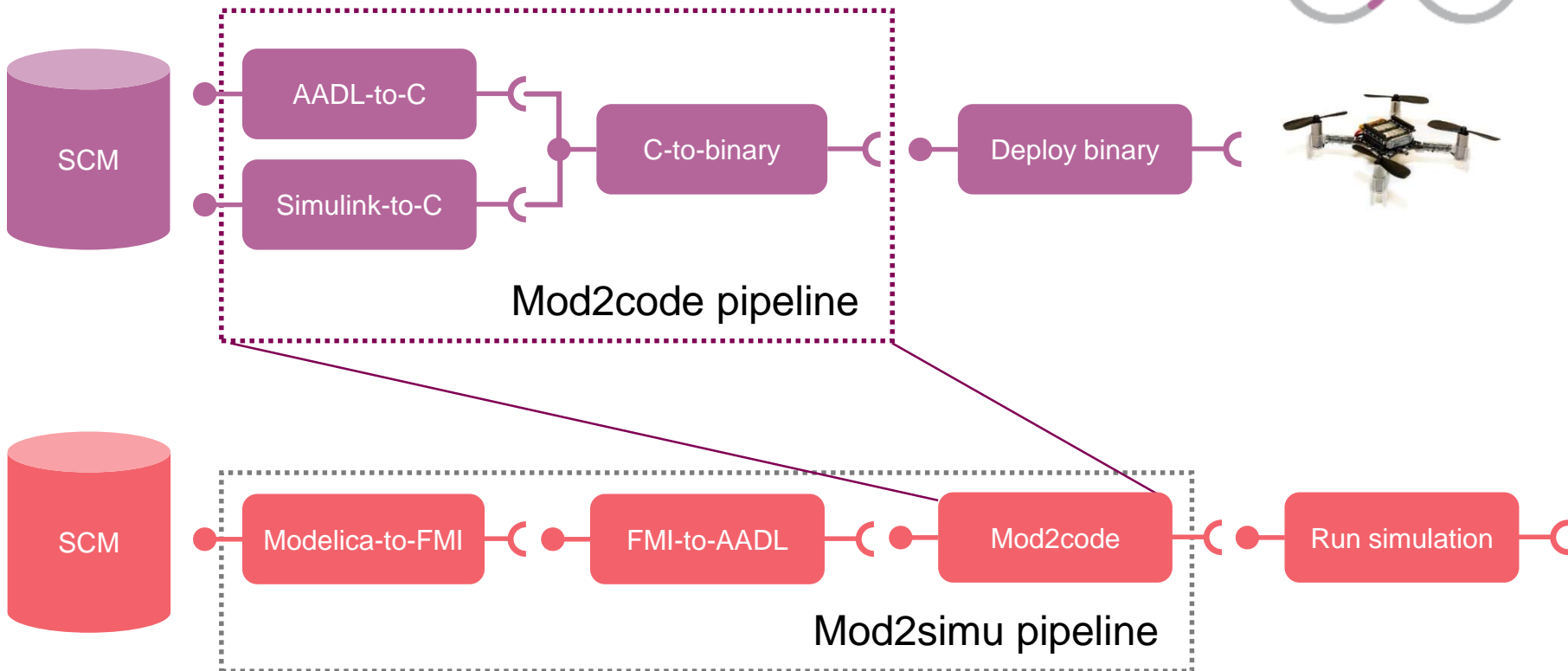

From ModDevOps to TwinOps

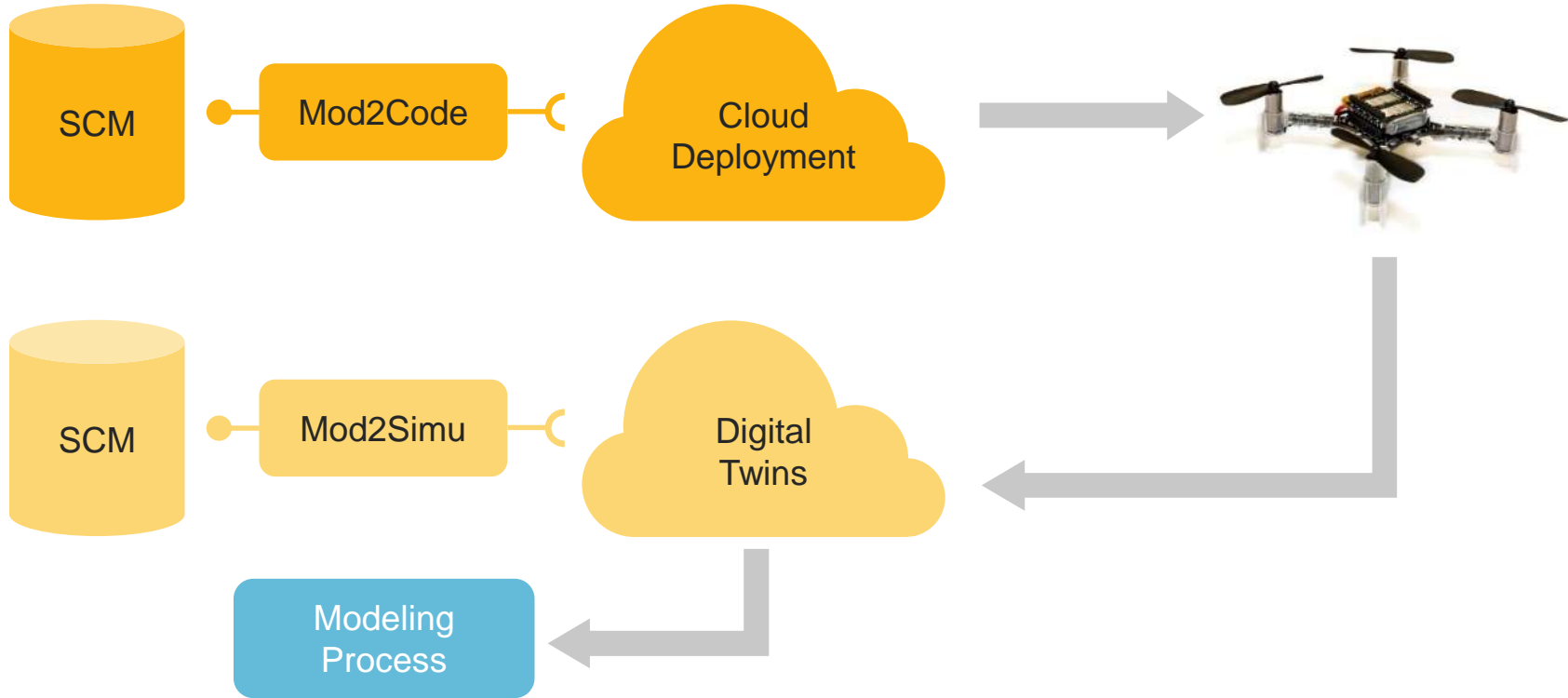

TwinOps: Continuous System Improvement through ModDevOps and Digital Twins

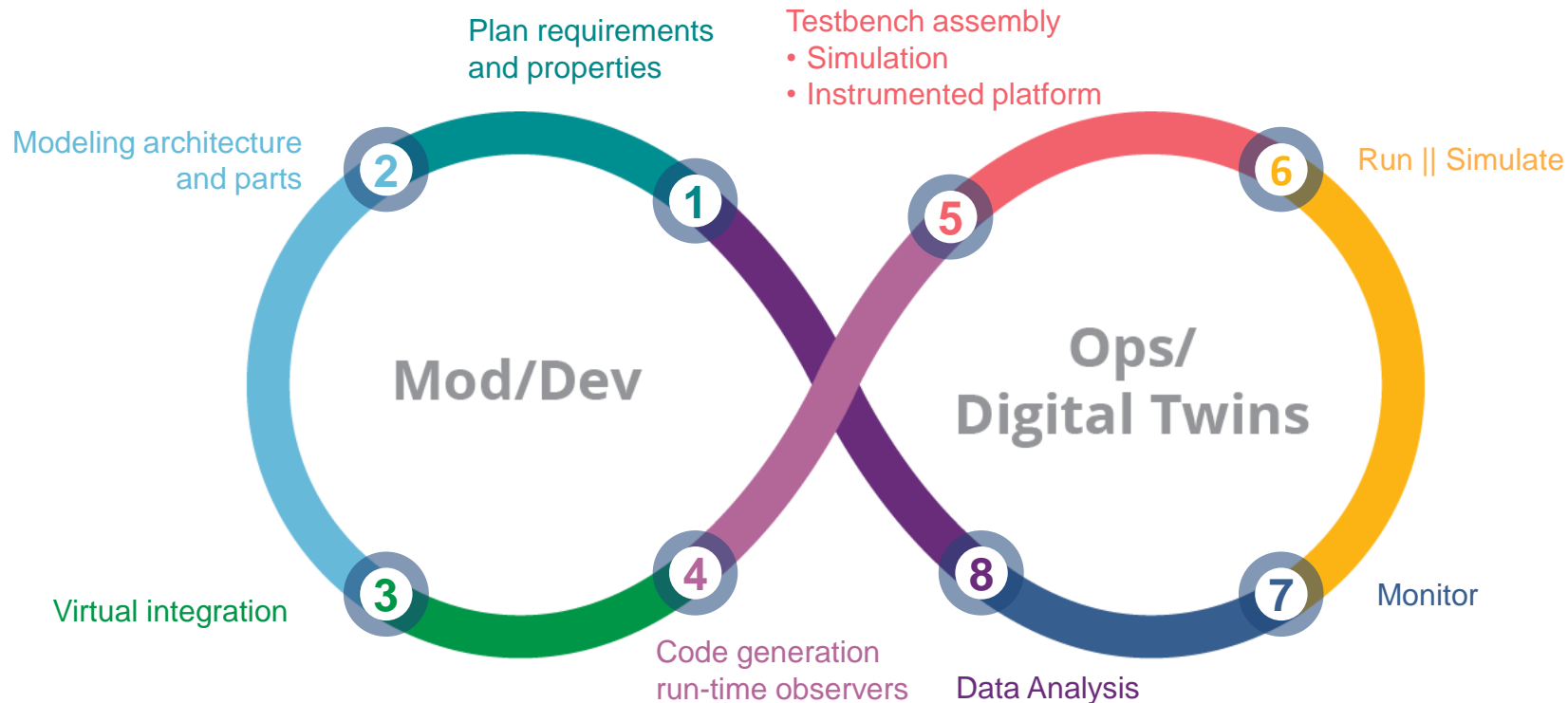

With TwinOps, the SEI delivered a ModDevOps exemplar, bridging Model-Based Systems Engineering and Software Engineering.

TwinOps improves analysis and testing capabilities by leveraging multiple models and combining them.

TwinOps Team Members

To learn more or collaborate, contact us at info@sei.cmu.edu.



Jerome Hugues



Joe Yankel



Anton Hristosov



John Hudak