



**NAVAL
POSTGRADUATE
SCHOOL**

MONTEREY, CALIFORNIA

THESIS

**IPOWER OPERATIONAL ANALYSIS: DISCRETE
EVENT SIMULATION**

by

Jonathan L. Clark

June 2020

Thesis Advisor:

Paul T. Beery

Second Reader:

Alejandro S. Hernandez

Approved for public release. Distribution is unlimited.

THIS PAGE INTENTIONALLY LEFT BLANK

REPORT DOCUMENTATION PAGE			<i>Form Approved OMB No. 0704-0188</i>
Public reporting burden for this collection of information is estimated to average 1 hour per response, including the time for reviewing instruction, searching existing data sources, gathering and maintaining the data needed, and completing and reviewing the collection of information. Send comments regarding this burden estimate or any other aspect of this collection of information, including suggestions for reducing this burden, to Washington headquarters Services, Directorate for Information Operations and Reports, 1215 Jefferson Davis Highway, Suite 1204, Arlington, VA 22202-4302, and to the Office of Management and Budget, Paperwork Reduction Project (0704-0188) Washington, DC 20503.			
1. AGENCY USE ONLY (Leave blank)	2. REPORT DATE June 2020	3. REPORT TYPE AND DATES COVERED Master's thesis	
4. TITLE AND SUBTITLE IPOWER OPERATIONAL ANALYSIS: DISCRETE EVENT SIMULATION			5. FUNDING NUMBERS
6. AUTHOR(S) Jonathan L. Clark			
7. PERFORMING ORGANIZATION NAME(S) AND ADDRESS(ES) Naval Postgraduate School Monterey, CA 93943-5000			8. PERFORMING ORGANIZATION REPORT NUMBER
9. SPONSORING / MONITORING AGENCY NAME(S) AND ADDRESS(ES) N/A			10. SPONSORING / MONITORING AGENCY REPORT NUMBER
11. SUPPLEMENTARY NOTES The views expressed in this thesis are those of the author and do not reflect the official policy or position of the Department of Defense or the U.S. Government.			
12a. DISTRIBUTION / AVAILABILITY STATEMENT Approved for public release. Distribution is unlimited.			12b. DISTRIBUTION CODE A
13. ABSTRACT (maximum 200 words) This thesis uses discrete event simulation and statistical methods to further analyze the U.S. Marine Corps Expeditionary Energy Office's IPOWER tool, which is currently focused on analysis of squad-level operations and scales the simulation to the platoon level. The results of this work show that there is significant variability when analyzing the mission parameters that have the largest impact on energy usage. The model developed by this thesis incorporates variability into the operator's decision, allowing the operator to see a distribution of possible outcomes, which represents the stochastic nature of military operations in more detail than is possible using IPOWER. This allows the operator to assume a level of risk, how much of the distribution to include, in determining the number of batteries required to complete the mission. It was determined that radio usage during the attack/intel phase and the radio's initial battery capacity are the most significant factors in all prediction models. The results of this thesis can help to improve the Marine Corps' management of the War Reserve Materiel Program, logistics planning for operations that require high energy demands, and wargame analysis.			
14. SUBJECT TERMS IPOWER, IPOWER analysis, discrete event simulation			15. NUMBER OF PAGES 89
			16. PRICE CODE
17. SECURITY CLASSIFICATION OF REPORT Unclassified	18. SECURITY CLASSIFICATION OF THIS PAGE Unclassified	19. SECURITY CLASSIFICATION OF ABSTRACT Unclassified	20. LIMITATION OF ABSTRACT UU

THIS PAGE INTENTIONALLY LEFT BLANK

Approved for public release. Distribution is unlimited.

IPOWER OPERATIONAL ANALYSIS: DISCRETE EVENT SIMULATION

Jonathan L. Clark
Lieutenant, United States Navy
BS, Xavier University, 2013

Submitted in partial fulfillment of the
requirements for the degree of

MASTER OF SCIENCE IN SYSTEMS ENGINEERING

from the

**NAVAL POSTGRADUATE SCHOOL
June 2020**

Approved by: Paul T. Beery
Advisor

Alejandro S. Hernandez
Second Reader

Ronald E. Giachetti
Chair, Department of Systems Engineering

THIS PAGE INTENTIONALLY LEFT BLANK

ABSTRACT

This thesis uses discrete event simulation and statistical methods to further analyze the U.S. Marine Corps Expeditionary Energy Office's IPOWER tool, which is currently focused on analysis of squad-level operations and scales the simulation to the platoon level. The results of this work show that there is significant variability when analyzing the mission parameters that have the largest impact on energy usage. The model developed by this thesis incorporates variability into the operator's decision, allowing the operator to see a distribution of possible outcomes, which represents the stochastic nature of military operations in more detail than is possible using IPOWER. This allows the operator to assume a level of risk, how much of the distribution to include, in determining the number of batteries required to complete the mission. It was determined that radio usage during the attack/intel phase and the radio's initial battery capacity are the most significant factors in all prediction models. The results of this thesis can help to improve the Marine Corps' management of the War Reserve Materiel Program, logistics planning for operations that require high energy demands, and wargame analysis.

THIS PAGE INTENTIONALLY LEFT BLANK

TABLE OF CONTENTS

I.	INTRODUCTION.....	1
A.	BACKGROUND	1
B.	PROBLEM DEFINITION	3
C.	THESIS OBJECTIVES.....	3
D.	SYSTEMS ENGINEERING APPROACH	4
II.	LITERATURE REVIEW	5
A.	IPOWER.....	5
1.	Energy Simulation	5
2.	Equipment Models	6
B.	EFFECTS ON LITHIUM-ION BATTERIES.....	8
C.	USMC DOCTRINE	9
1.	USMC Infantry Battalion	10
2.	USMC Rifle Squad Offensive Operations	13
3.	USMC Communication	15
III.	SCENARIO AND MODEL ARCHITECTURE	17
A.	MODEL VIGNETTE	17
B.	MODEL ARCHITECTURE.....	19
1.	Plan.....	22
2.	Observe	24
3.	Attack and Secure Area.....	25
IV.	MODEL SIMULATION AND ANALYSIS	27
A.	DESCRIPTION OF EXTENDSIM MODEL.....	27
B.	EXPERIMENT FACTORS AND RANGES	28
C.	DESIGN OF EXPERIMENT.....	30
D.	DATA ANALYSIS (1-TO-1 COMPARISON)	31
E.	REGRESSION ANALYSIS	33
1.	Total AN/PRC-153 Batteries.....	33
2.	Partition for Total AN/PRC-153 Batteries	36
3.	Total AN/PRC-153 Amp-Hours.....	39
4.	Top Five Significant Factors	41
V.	CONCLUSIONS AND RECOMMENDATIONS.....	43
A.	SUMMARY	43
B.	CONCLUSION	44

C.	FUTURE WORK	45
APPENDIX A.	EXTENDSIM MODEL.....	47
A.	PLAN PHASE	47
B.	OBSERVE PHASE	48
C.	ATTACK PHASE	49
D.	SECURE PHASE	50
E.	ENERGY CONSUMPTION CALCULATIONS.....	51
APPENDIX B.	ADDITIONAL REGRESSION ANALYSIS.....	53
A.	TOTAL AN/PRC—150 BATTERIES	53
1.	Stepwise Regression	53
2.	Prediction Plot and Summary of Fit	53
3.	Model Variables	54
B.	TOTAL AN/PRC—117 BATTERIES	54
1.	Stepwise Regression	54
2.	Prediction Plot and Summary of Fit	55
3.	Model Variables	55
C.	TOTAL AN/PRC—152 BATTERIES	56
1.	Stepwise Regression	56
2.	Prediction Plot and Summary of Fit	56
3.	Model Variables	57
D.	TOTAL AN/PRC—148 BATTERIES	57
1.	Stepwise Regression	57
2.	Prediction Plot and Summary of Fit	58
3.	Model Variables	58
E.	TOTAL AN/PSN—13(B) DAGR BATTERIES	59
1.	Stepwise Regression	59
2.	Prediction Plot and Summary of Fit	59
3.	Model Variables	60
LIST OF REFERENCES	61
INITIAL DISTRIBUTION LIST	63

LIST OF FIGURES

Figure 1.	IPOWER User Workflow. Source: Stroman (2018b).....	5
Figure 2.	Energy-Power Index (EPI) Profile of Lithium-Ion Cells. Source: Kumar et al. (2018).	9
Figure 3.	General Organization of a Marine Corps Rifle Company. Adapted from U.S. Marine Corps (2015).....	11
Figure 4.	Marine Rifle Squad. Source: U.S. Marine Corps (2019b).....	12
Figure 5.	Penetration. Source: U.S. Marine Corps (2019a).	14
Figure 6.	Vignette Phase 1 (Intel Collection). Source: Alisa et al. (2019).....	17
Figure 7.	Vignette Phase 2. Source: Alisa et al (2019).	18
Figure 8.	High-Level Input-Output Diagram	19
Figure 9.	High-Level EFFBD.....	20
Figure 10.	Platoon Commander EFFBD	21
Figure 11.	Plan Functional Flow Block Decomposition	22
Figure 12.	Observe Functional Flow Block Decomposition	24
Figure 13.	Attack Functional Flow Block Decomposition.....	25
Figure 14.	ExtendSim 10 Model	27
Figure 15.	NOB Design (First 29 Design Points)	31
Figure 16.	Total AN/PRC-153 Batteries Histogram and Data Summary	32
Figure 17.	JMP Stepwise Regression Analysis of the Total AN/PRC-153 Batteries	34
Figure 18.	Total AN/PRC-153 Batteries Actual by Prediction Plot and Summary of Fit	35
Figure 19.	Total AN/PRC-153 Batteries Effects Summary Shows Factor Significance.....	35
Figure 20.	JMP Optimal (default) Partition of the Total AN/PRC-153 Batteries	36

Figure 21.	Partition of Total AN/PRC-153 Batteries Using the Attack Usage Rate and Battery Capacity	37
Figure 22.	Partition of Total AN/PRC-153 Batteries Using Battery Capacity	38
Figure 23.	JMP Stepwise Regression Analysis of the Total AN/PRC-153 Amp-Hours.....	39
Figure 24.	Total AN/PRC-153 Amp-Hours Actual by Prediction Plot and Summary of Fit	40
Figure 25.	Total AN/PRC-153 Amp-Hours Effects Summary Shows Factor Significance.....	40
Figure 26.	ExtendSim 10 Model (Plan Phase)	47
Figure 27.	ExtendSim 10 Model (Observe Phase).....	48
Figure 28.	ExtendSim 10 Model (Attack Phase).....	49
Figure 29.	ExtendSim 10 Model (Secure Phase)	50
Figure 30.	ExtendSim 10 Model (Energy Consumption Calculations).....	51
Figure 31.	JMP Stepwise Regression Analysis of the Total AN/PRC-150 Batteries	53
Figure 32.	Total AN/PRC-150 Batteries Actual by Prediction Plot and Summary of Fit	53
Figure 33.	Total AN/PRC-150 Batteries Effects Summary Shows Factor Significance.....	54
Figure 34.	JMP Stepwise Regression Analysis of The Total AN/PRC-117 Batteries.	54
Figure 35.	Total AN/PRC-117 Batteries Actual by Prediction Plot and Summary of Fit	55
Figure 36.	Total AN/PRC-117 Batteries Effects Summary Shows Factor Significance.....	55
Figure 37.	JMP Stepwise Regression Analysis of the Total AN/PRC-152 Batteries	56
Figure 38.	Total AN/PRC-152 Batteries Actual by Prediction Plot and Summary of Fit	56

Figure 39.	Total AN/PRC-152 Batteries Effects Summary Shows Factor Significance.....	57
Figure 40.	JMP Stepwise Regression Analysis of the Total AN/PRC-148 Batteries	57
Figure 41.	Total AN/PRC-148 Batteries Actual by Prediction Plot and Summary of Fit	58
Figure 42.	Total AN/PRC-148 Batteries Effects Summary Shows Factor Significance.....	58
Figure 43.	JMP Stepwise Regression Analysis of the Total AN/PSN – 13(B) DAGR Batteries	59
Figure 44.	Total AN/PSN – 13(B) DAGR Batteries Actual by Prediction Plot and Summary of Fit	59
Figure 45.	Total AN/PSN – 13(B) DAGR Batteries Effects Summary Shows Factor Significance	60

THIS PAGE INTENTIONALLY LEFT BLANK

LIST OF TABLES

Table 1.	Infantry Battalion Equipment List. Source: Marine Corps Combat Development and Integration (2018).....	16
Table 2.	Model Equipment List	21
Table 3.	Efficiency Table.....	23
Table 4.	List of Experiment Factors.....	29
Table 5.	Prediction Model Top Significant Factors	41

THIS PAGE INTENTIONALLY LEFT BLANK

LIST OF ACRONYMS AND ABBREVIATIONS

Ah	Amp-hours
AN/PRC	Army – Navy / Portable Radio Communications
AN/PSN	Army – Navy / Portable Special Navigation Aid
AOR	area of operation
BIC	Bayesian Information Criterion
C4ISR	command, control, communications, computer, intelligence, surveillance and reconnaissance
DAGR	Defense Advanced GPS Receiver
DOE	design of experiment
E2O	Expeditionary Energy Office
EFFBD	Enhanced Functional Flow Block Diagram
EPI	energy power index
ESR	equivalent series resistance
H&S	Headquarters and services
INCOSE	The International Council on Systems Engineering
IPOWER	Intelligent Power Optimization with Environmental Reactivity
LIB	lithium-ion batteries
MAGTAF	Marine Air Ground Task Force
MBSE	model-based systems engineering
ME	mission engineering
NAI	named area of interest
NLOH	Nearly Orthogonal Latin Hypercube
NOB	Nearly Orthogonal and Balanced
NPS	Naval Postgraduate School
OCV	open interpolated circuit voltage
SoC	state of charge
USMC	United States Marine Corps

THIS PAGE INTENTIONALLY LEFT BLANK

EXECUTIVE SUMMARY

The objective of this thesis is to inform U.S. Marine Corps (USMC) operational energy policy through an analysis of battery usage in infantry operations. In support of that broader objective, this thesis conducts analysis of the USMC Expeditionary Energy Office's IPOWER tool, a deterministic program which only focused on squad level operations, by developing a scalable simulation. To achieve this objective, it was important incorporate operational/environmental variability and use a statistical method to make recommendations to inform decision-maker's understanding on what variables have the largest impact on battery usage.

The USMC developed IPOWER as a tool to aid its warfighters/mission-planners in analyzing energy consumption by varying mission equipment and mission profiles. According to Stroman (2018), the IPOWER tool allows its operators to construct mission profiles (timelines) using its pre-defined mission blocks and additionally the operator is able to vary location, temperature, unit structure, activity timeline (durations) and carried equipment. IPOWER will output a consumed energy analysis and determine the required number of batteries to complete the mission. IPOWER uses built-in equations to account for temperature's effect on battery efficiency but does not account for the batteries state of charge (SoC). IPOWER assumes all batteries are 100% full, but the SoC may depreciate as the battery ages prior to use.

The vignette developed by Alisa et al. (2019) and their results were used to develop an expanded systems architecture that can serve as the basis for an operational simulation model in ExtendSim. The vignette consists of a Marine rifle squad and platoon commander conducting a penetration maneuver against an opposing force, which can be described in two major phases consisting of the plan/intel collection phase and the attack phase. Phase one consists of two activities which include mission planning and the collection of enemy intelligence. The mission planning and activity durations are assumed by Alisa et al. Phase two of the vignette consists of the actual penetration attack and does not concluded until after OPFOR has retreated and BLUFOR clears the area.

Using the capstone teams’ vignette (Alisa et al. 2019), a high-level EFFBD was created to show the inputs and variables that will determine the output of the ExtendSim model. The objective of this model is to determine the energy consumption of the platoon squad throughout the mission. From the energy consumption the number of batteries needed by the platoon can be determined. The model tracks and outputs the energy consumption of the specific equipment used by individual type (Figure 1). The individual types consist of one platoon commander, one squad leader, three fire team leaders and nine riflemen.

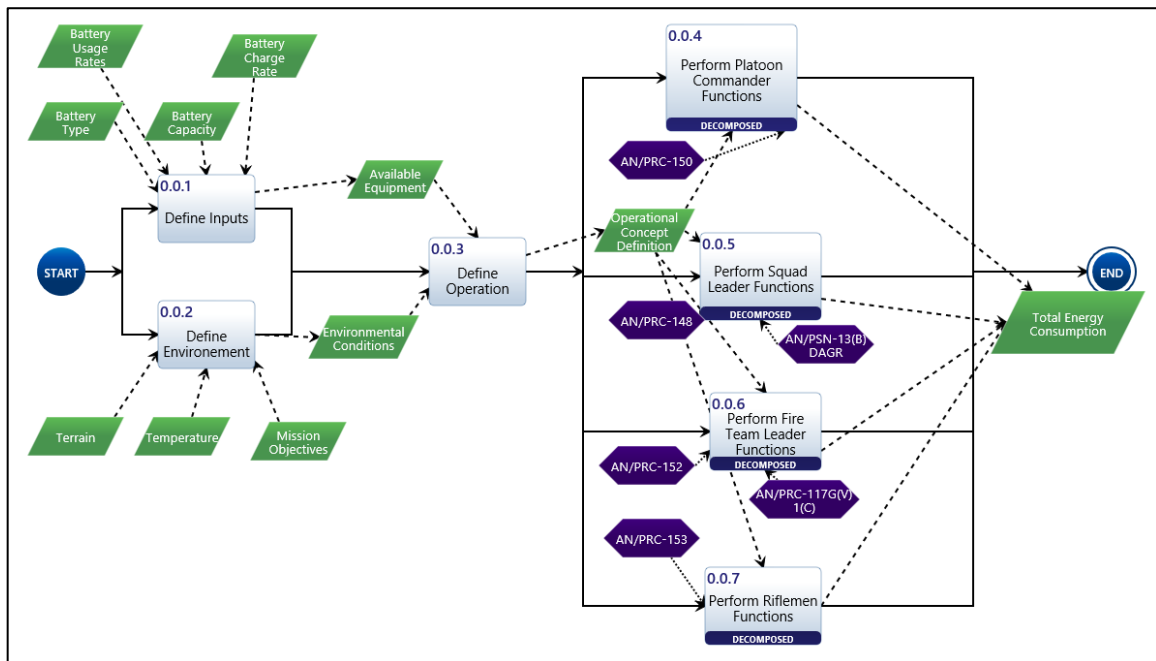

Figure 1. High-Level EFFBD

The mission described by Alisa et al. was decomposed into four essential functions (Plan, Observe, Attack and Secure Area) that the rifle squad must complete to accomplish the mission. All individual types go through the same function tasks throughout the model. The model tracks the energy consumption during each activity, accumulates the total energy consumption of each individual and equipment type at the end of the model.

Following the modeling approach described in MacCalman et al. (2016), an ExtendSim model was created incorporating the architecture and operational concepts. Figure 2 depicts the high-level functions/tasks (Plan, Observe, Attack and Secure) that must be accomplished to complete the mission.

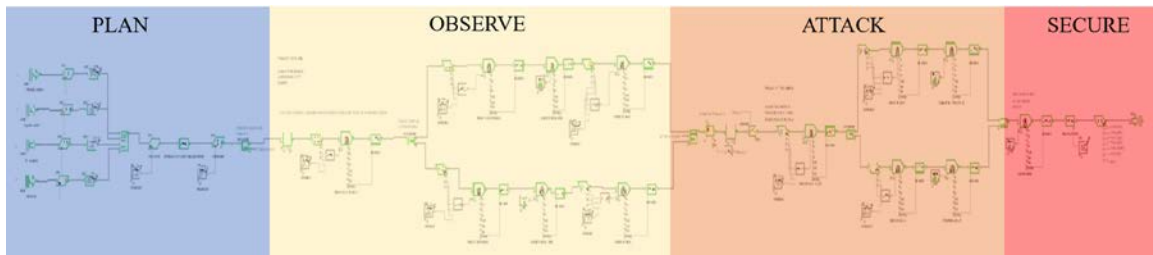

Figure 2. ExtendSim Model

The ExtendSim model produces the amp-hours used by individual type and equipment type. The number of batteries needed by equipment type is then calculated by a set of equation blocks.

A range of range environmental variables, system variables and operational variables were used in the Nearly Orthogonal and Balanced (NOB) design template, developed by Vieira et al. (2013), to create 512 design points for the design of experiment (DOE). Each of the 512 design points were replicated thirty times. Using the central limits theory, a sample size of 30 will sufficiently account for the variability associated with each individual model run. This ultimately resulted in 15,360 simulation runs.

One of the goals of this thesis is to compare the data analysis conducted by Alisa et al. (2019) with the results of this thesis ExtendSim model. The team focused on the AN/PRC-153 (handheld radio) as it had the highest usage throughout the mission. The team's analysis (Alisa et al. 2019) consisted of four simulations assessing the capability of IPOW. The NOB design provides a much broader and more robust experiment design, creating 512 design points or scenario variations versus only looking at 4 variations. Figure 3 shows the results for the total AN/PRC-153 batteries required to complete the mission. The results show the riflemen (nine total riflemen) required a mean of 22.83 battery packs to complete the mission. Since it is impractical to carry only 0.83 of a battery,

we will assume the model requires 23 batteries. The capstone teams baseline analysis, variations 1 and 2 would equate to 29.7 batteries, 40.5 batteries and 31.5 batteries required for a total of 9 riflemen.

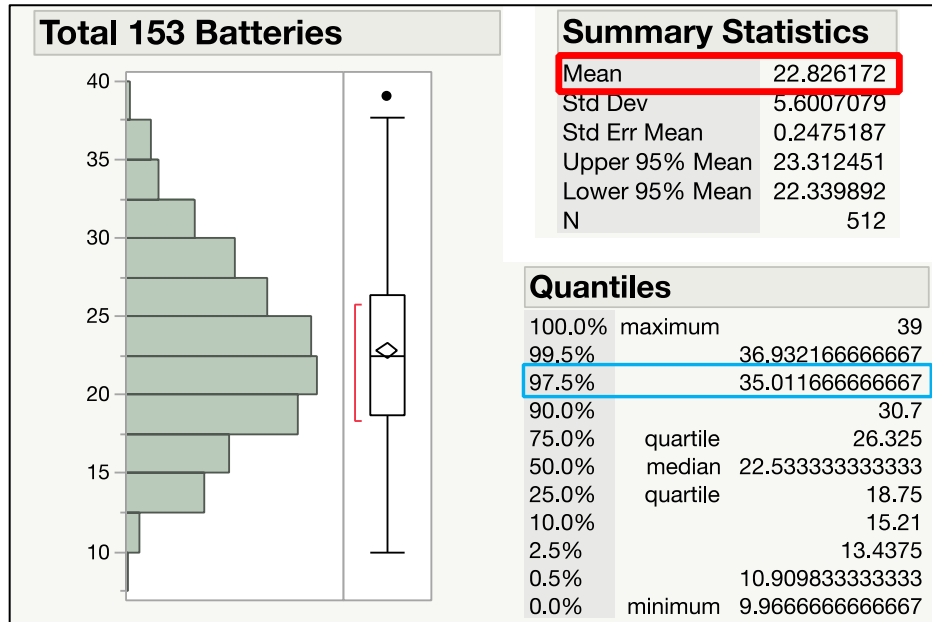

Figure 3. Total AN/PRC-153 Batteries' Histogram and Data Summary

Their results are shown to fall on the higher end of the distribution created by JMP. The capstone teams baseline model and variation 2 fall with the 97.5% quantile while variation 1 exceeds the maximum value of the distribution.

Through regression analysis, this thesis explored the other equipment used in this model to see what factors had the most impact on the batteries required. Table 1 lists the top five variables used in their respective prediction models, shown in order of significance.

Table 1. Prediction Model Top Significant Factors

	Total AN/PRC 153 Batteries	Total AN/PRC 152 Batteries	Total AN/PRC 117 Batteries	Total AN/PRC 148 Batteries	Total AN/PRC 150 Batteries
1	Attack Usage Rate	Attack Usage Rate	Attack Usage Rate	Attack Usage Rate	Battery Capacity %
2	Battery Capacity %	Battery Capacity %	Battery Capacity %	Battery Capacity %	Attack Usage Rate
3	Intel Usage Rate	Intel Usage Rate	Intel Usage Rate	Intel Usage Rate	Temperature
4	Temperature	Temperature	Battery Cap% * Attack usage rate	Battery Cap% * Attack usage rate	Intel Usage Rate
5	Battery Cap% * Attack usage rate	Battery Cap% * Attack usage rate	Troop Speed (m/s)	Battery Cap% * Intel usage rate	Troop Speed (m/s)

Radio usage during the attack/intel phase and the radio’s battery capacity were significant factors in all prediction models. In addition, those three factors had the same order of precedence in all the models except for the AN/PRC-150. Both the AN/PRC-153 and AN/PRC-152 had the same top five factors and both prediction models have extremely significant correlation to the data

This thesis shows that IPOWERS is capable of calculating energy usage and additionally this work highlights the potential limitations of IPOWERS. All models are only as reliable as the assumptions that constrain their output. Opportunities for error occur without accurate equipment databases and for operators with limited to no operational experience. Due to a lack of available information from product descriptions, some assumptions were needed to define radio set performance parameters. Additionally, IPOWERS gives significant control to the user by allowing the operator to define mission parameters, equipment usage rates, durations and equipment parameters. This thesis, through experimental design, shows there is significant variability when trying to define mission parameters in a program like IPOWERS. It is impossible to predict exact mission durations, exactly how fast forces will travel, exact environmental conditions, initial battery capacities and their usage rates. This amount of variability can significantly influence IPOWERS’s output and may give an unrealistic answer. The model developed by this this thesis incorporates variability into the user’s decision, allowing the operator to see a distribution of possible outputs. This allows the operator to assume a level of risk, how much of the distribution to include, in determining the appropriate number of batteries required.

References

- Alisa, Rasida, Mark A. Kotwicki II, and Peter J. Marbach. 2019. Assessing the Impact of Tactical Mission Profiles on The Development of Power Prediction Software. Systems Engineering Capstone Report, Naval Postgraduate School.
- MacCalman, Alex, Paul Beery, and Eugene Paulo. (2016). “A Systems Design Exploration Approach that Illuminates Tradespaces Using Statistical Experimental Designs.” *Systems Engineering* 19, no. 5(September): 409–421. <https://doi.org/10.1002/sys.21352>.
- Stroman, Richard. 2018. *IPOWER: Dismounted Soldier Energy Analysis and Mission Planning Tools*. Washington, DC: U.S. Naval Research Laboratory. <http://www.powersourceconference.com/Power%20Sources%202018%20Digest/docs?8-1.pdf>.
- Vieira, H., Susan M. Sanchez, K.H. Kienitz, and M.C.N. Belderrain. 2013. Efficient, Nearly Orthogonal-and-Balanced, Mixed Designs: An Effective Way to Conduct Trade-Off Analyses via Simulation. *Journal of Simulation* 7: 264–275. <http://hdl.handle.net/10945/44877>.

ACKNOWLEDGMENTS

I would like to sincerely thank my advisor Dr. Paul Beery. This thesis would not have been possible without his expertise, dedication and patience in guiding me through this process. I would also like to thank Dr. Alejandro Hernandez for his guidance and continuous encouragement throughout my time at NPS. The professors in the Systems Engineering Department show true dedication and continue to promote a positive learning environment.

THIS PAGE INTENTIONALLY LEFT BLANK

I. INTRODUCTION

A. BACKGROUND

In February 2011, the Commandant of the Marine Corps signed the *Expeditionary Energy Strategy and Implementation Plan*, declaring energy as one of his top priorities. Due to operational strategies that increased dependence on energy, the new plan stated:

The current and future operating environment requires an expeditionary mindset geared toward increased efficiency and reduced consumption, which will make our forces lighter and faster. We will aggressively pursue innovative solutions to reduce energy demand in our platforms and systems, to increase our self-sufficiency in our sustainment, and reduce our expeditionary footprint on the battlefield. Transforming the way we use energy is essential to rebalance our Corps and prepare it for the future. (Marine Requirements Oversight Council 2011)

Technology has increased Marine Corps capability in precision weapons strikes and in command, control, communications, computer, intelligence, surveillance and reconnaissance (C4ISR). That increase in precision strike and capability has resulted in an associated increase in sustainability and supportability challenges. Notably in “over 70 percent of logistics required to sustain Marine Corps expeditionary forces ashore is liquid, fuel and water” (Marine Requirements Oversight Council 2011, 1). Since 2001 the Marine Air Ground Task Force (MAGTAF) has seen a 250% increase in radios, and a 300% increase in computer and new system technologies (Marine Requirements Oversight Council 2011, 1). Infantry battalions have increased vehicle numbers by 200% for distributed mobility (Marine Requirements Oversight Council 2011, 1)The increased demand for fuel (energy) poses as an increased vulnerability. The Commandant of the Marine Corps 2025 Vision and Strategy states the Marine Corps will:

- achieve resource self-sufficiency in our battlefield sustainment
- reduce energy demand in our platforms and systems
- reduce our overall footprint in current and future expeditionary operations. (Marine Requirements Oversight Council 2011, 1)

This recent emphasis on resource self-sufficiency and reduced energy demand is an expansion of work over the past several decades. In 1996, the Analytical Systems

Engineering Company reviewed battery support to Marine forces. Their final report consisted of a study of the Marine Corps battery management revealing a gap due to a lack of comprehensible plan or methodology to manage battery consumption. During Desert Storm, there was evidence of excess requisitions and improper battery storage causing shorter battery lifespans which increased disposal rates and high logistic strain (Analytical Systems Engineering Corporation 1996). The final report also revealed additional key points:

- There was no complete list of Marine Corps ground equipment items which use batteries, and the type(s) of batteries each item uses.
- Most Marine Corps units do not maintain battery usage data.
- Only some technical manuals contained battery use data.
- Battery-using equipment with the Marine Corps equipment inventory changes often, but corresponding data on battery usage does not tend to keep up with the changes.
- The economically efficient ordering quantities for non-rechargeable batteries are not precisely known, but the current practice of ordering very large quantities infrequently and at uneven intervals is inefficient. (Analytical Systems Engineering Corporation 1996)

To assist with the new energy initiative, the USMC founded the Expeditionary Energy Office (E2O) in 2009 to guide expeditionary energy across all warfighting functions. E2O has supported that tasking through development of energy specific analysis tools with multiple U.S. Navy research institutions. Notably, “The U.S. Naval Research Laboratory began working with the U.S. Army Research Development and Engineering Command, Communications-Electronics Research, Development and Engineering Center in 2014 to simulate how Soldiers use energy” (Stroman 2018a, 119). The E2O has developed the Intelligent Power Optimization with Environmental Reactivity (IPOWER) software as a method to inform acquisition requirements and mission planning concerning energy management. To this point, the IPOWER software has restricted analysis to deterministic assessment of specific scenarios. This thesis seeks to expand that scope through a stochastic analysis of energy and battery usage in multiple scenarios.”

B. PROBLEM DEFINITION

The USMC relies on a propriety software program, named IPOWER, to conduct operational analysis of small unit power requirements. To expand the detail and rigor associated with that analysis, this thesis will define a USMC ground force mission profile through analysis of USMC doctrine and utilized equipment to evaluate the success of an energy-area mission. Additionally, it will examine the operational, environmental, and unit configuration decisions that have the largest impact on battery usage.

C. THESIS OBJECTIVES

Conducting an analysis of the IPOWER software will help improve the Marine Corps management of the War Reserve Materiel Program, aid in the logistics of mission planning requiring high demands of energy and aid in the analysis (war gaming) of plausible future vignettes to develop future military strategies.

This thesis uses statistical methods to further analyze E2O's IPOWER tool, which is currently focused on analysis of squad level operations and scales the simulation to the platoon level. This study will further increase decision makers ability to support Marines in tactical environments. Accordingly, the following steps will be executed to support the analysis method:

1. Define/Create an IPOWER mission profile/mission block and operating conditions and equipment applicable to current USMC operations.
2. Develop an overall systems architecture that captures the operational activities and system elements associated with USMC small unit operations.
3. Create a discrete simulation in ExtendSim of the defined IPOWER mission and outputs.
4. Provide analysis of simulation to identify key performance factors and compare results with IPOWER's outputs

D. SYSTEMS ENGINEERING APPROACH

This thesis integrates recent work in model-based systems engineering (MBSE) and mission engineering (ME) to define and develop a consistent system architecture, mission profiles, and operational simulation models. The International Council on Systems Engineering (INCOSE) defines model-based systems engineering (MBSE) as “the formalized application of modeling to support system requirements, design, analysis, verification and validation activities beginning in the conceptual design phase and continuing throughout the development and later life cycle phase” (INCOSE 2007, 15). The Office of the Deputy Assistant Secretary of Defense for Systems Engineering defines Mission Engineering (ME) as the “deliberate planning, analyzing, organizing, and integrating of current and emerging operational and system capabilities to achieve desired warfighting mission effects” (Gold 2016). According to Beery and Paulo (2019, 1), both “MBSE and ME have gained significant traction throughout the domain of systems engineering, as well as with the Department of Defense.” This thesis assumes stakeholder analysis was previously conducted, an appropriate problem and need was determined in the creation of IPOWER. This work will continue to focus on the Conceptual/Preliminary Design phase of the system life cycle.

This thesis integrates the methodology of MBSE into ME to apply a mission simulation model for further analysis and to support the creation of IPOWER’s requirements, system design and system analysis. The integration of these concepts and results of this thesis may increase the understanding of IPOWER’s capabilities and how the warfighter can further implement the system in mission planning.

II. LITERATURE REVIEW

A. IPOWER

The objective of this research is to further analyze the IPOWER software by conducting a discrete event simulation using the mission parameters defined by IPOWER. It is important to understand IPOWER's processes so analysts and decision makers are enabled in planning “energy-aware missions in the field, analyzing prospective Soldier power systems and components, quantitatively explore energy-related ‘what if’ scenarios” (Stroman 2018a, 119).

1. Energy Simulation

According to (Stroman 2018a) IPOWER is a time-based model that uses algorithms with inputs of mission equipment and mission profiles (location, unit structure, timeline, carried equipment, and power system topology) to produce its analysis. The program analysis incorporates location and a series of distinct waypoints (start and end times) where certain mission activities are defined. Figure 1 presents a high-level overview of the IPOWER workflow. Operators are able to construct mission profiles (timelines) using IPOWER's pre-defined “mission blocks” (Stroman 2018a).

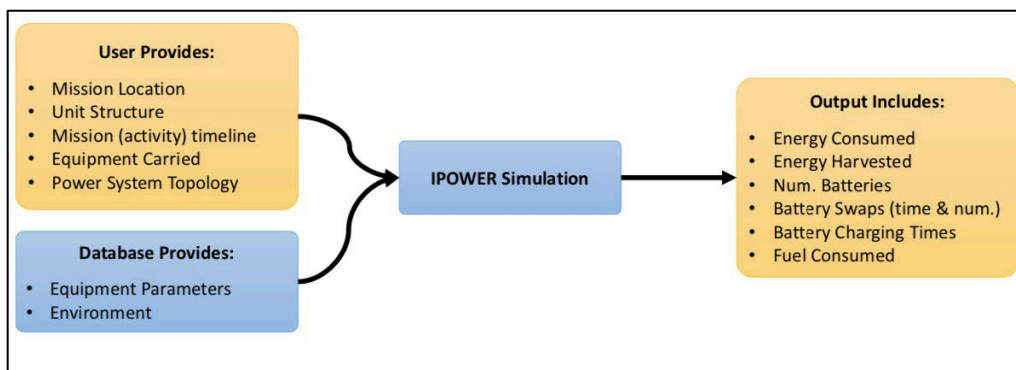

Figure 1. IPOWER User Workflow. Source: Stroman (2018b).

IPOWER operators are able to designate between three categories of equipment (loads, energy harvesters and batteries). Equipment and quantity can be assigned to specific

team members where some are using loads with batteries and/or energy harvesters. IPOWER gives the operator the option of displaying three different sets of results. Under the “selected run” option IPOWER only includes the equipment originally selected and carried during the mission. The “battery run” option identifies the minimum number of batteries that must be carried for mission success. The “optimized run” determines the lightest combination of selected equipment a soldier must carry for a successful mission. The result of each analysis is a plot of battery state of charge (SoC) throughout the mission (Stroman 2018a).

2. Equipment Models

IPOWER leverages an equipment database and parameters that dictate power consumption and production. The verified equipment database contains specifications of weight, material and performance data. Understanding IPOWER’s equipment model during active states will aid in the development of the discrete simulation. Equipment is categorized into three different types and modeled according to their type.

- Loads: Each load draws power at a rate dictated by a load model parameterized by soldier activity. IPOWER assumes most loads are consistent and correlate with soldier activity. This approach excludes loads that may vary due to frequency (network) settings topology or topographical interferences and assumes a nominal value (Stroman 2018).
- Energy Harvesters: Harvesters are separated into two classes: solar harvesters and kinetic harvesters. Solar harvesters are photovoltaic solar panels, whereas kinetic harvesters include knee-brace, rucksack, and other energy harvesters that convert soldier motion into electrical power (Stroman 2018). Kinetic energy harvesters are databased, similar to the loads, on the average power harvested solely based on soldier activity. Photovoltaic panel energy harvest is computed (equation 1) at each time increment as function irradiance (I_{ga}), the area of the solar panel (A_{panel}) and efficiency $\eta_{panel}(T)$ due to temperature. Assuming the panel is

horizontally positioned or positioned for maximum irradiance the power produce is estimated.

$$P_{Solar} = I_{ga}A_{panel}\eta_{panel}(T) \quad \text{IPOWER Eq. 1}$$

The temperature dependent efficiency (percentage) is found using equation 2.

$$\eta_{solar}(T) = \eta_{@25^{\circ}C} + 100C_T(T - 25) \quad \text{IPOWER Eq. 2}$$

IPOWER defines $\eta_{@25^{\circ}C}$ as the efficiency at $25^{\circ}C$ and C_T is the corresponding temperature coefficient (Stroman 2018a).

- Battery: Battery usage and operation is the most detailed model to capture real-world performance as accurately as possible. SoC is tracked by integrating the flow of charge into/out of the battery and comparing to the total charge capacity of the battery. Charge capacity varies with ambient temperature and SoC according to an empirical model created through battery measurements in an environmental chamber (Stroman 2018a). Using open interpolated circuit voltage (OCV) values and equivalent series resistance (ESR) values from a database the battery voltage is calculated using equation 3.

$$V_{bat}(t) = \frac{1}{2}(V_{ocv}(t) + \sqrt{V_{ocv}(t)^2 - 4P_{batt}(t)R_{esr}(t)}) \quad \text{IPOWER Eq. 3}$$

Equation 4 uses the empirical voltage to calculate current.

$$I_{bat}(t) = P_{batt}(t)/V_{batt}(t) \quad \text{IPOWER Eq. 4}$$

Equation 5 estimates the total charge removed or added to the battery.

$$Q_{bat}(t) = Q_{batt} + \int_0^t I_{bat}(t)dt \quad \text{IPOWER Eq. 5}$$

Equation 6 is then used to determine the state of charge

$$SoC(t, T) = \frac{Q_{batt}(t)}{Q_{batt, total}(T)} \quad IPOWER \text{ Eq. 6}$$

B. EFFECTS ON LITHIUM-ION BATTERIES

It is important to have a general understanding of how a battery's performance is affected by external and internal factors to implement specific characteristics into a desired model. Lithium-ion batteries (LIB) have become common power sources in numerous commercial and military electronics. A LIB's performance is dependent on the batteries state of health, discharge/charge rates and temperature (Kumar et al. 2018). The state of health of a battery is affected by age. Over time, the conductivity of the electrochemical process (reaction between anodes, cathodes caused by an electrolyte) becomes degraded causing an overall increase of internal cell resistance (Kumar et al. 2018). High discharge and charge current rates cause LIBs to approach voltage limits faster. This causes the batteries not to be able to fully charge or discharge, ultimately decreasing the total energy capacity and increasing internal resistance. Ambient temperature is also a significant factor in battery performance. Like most reactions, the rate of the chemical reaction between the cathode, anode and electrolyte (battery cell) are sensitive to temperature. In a certain range the rate of reaction will increase as the temperature increases. "In general, temperature dependence of energy has a bell shape starting with an increase up to a maximum then energy decreases with temperature" (Kumar et al. 2018, A674).

The Electrochemical Society released a report on an experiment conducted on lithium-ion cells. The cells were exothermically discharged at temperatures between -25° C to 55° C at varying C-rates (discharge current rate). The experiment produced Ragone plots showing the voltage over capacity allowing the research team to create the Energy-Power Index (EPI). Figure 2 presents an overview of EPI, emphasizing that the "EPI (in %) is defined as the ratio of the root squared integrated area under the Ragone profile achieved at temperature T vs. the same achieved at 25° C" (Kumar et al. 2018).

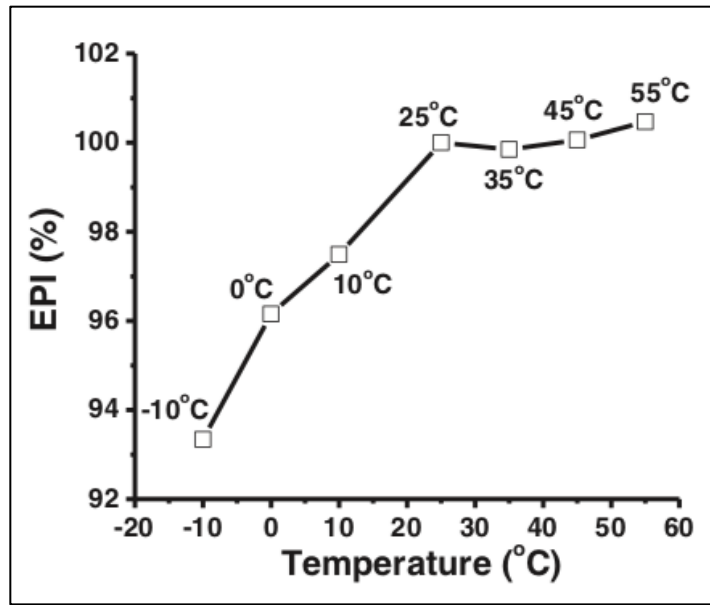

Figure 2. Energy-Power Index (EPI) Profile of Lithium-Ion Cells. Source: Kumar et al. (2018).

Figure 2 shows a near linear increase in LIB efficiency up 25° C and becoming more stable from 25° C to 55° C. The study concluded the LIBs have relatively good performance at a wide range of temperatures achieving optimal performance around 25° C.

C. USMC DOCTRINE

Conducting a discrete event simulation with the addition of variability (limited randomness) will aid in further analysis of the IPOWER software. To achieve the objectives of this research, it is important to review Marine Corps doctrine to understand the missions that IPOWER is capable of modeling and to develop separate models simulating a single mission. The Marine Corps structure, energy equipment utilized by individual Marines, and basic mission tactics are relevant to this thesis. This study will focus on a single rifle squad and their particular mission objectives within a rifle company. The goal will be to produce a scalable product than can be applied to the platoon and company levels.

1. USMC Infantry Battalion

The mission of an USMC infantry battalion as “to locate, close with, and destroy the enemy by fire and maneuver or to repel an enemy’s assault by fire and close combat” (U.S. Marine Corps 2015). An infantry battalion will generally consist of a “headquarters and services (H&S) company, a weapons company, and three rifle companies” (U.S. Marine Corps 2015, 5-5). The H&S company oversees the operations of the battalion and supporting units by providing the infantry battalion commander the necessary command and control resources. Weapons company supports the battalion’s scheme of maneuver by providing “medium mortar, antiarmor, heavy machine gun support, and fire support coordination” (U.S. Marine Corps. 2015, 5-7). An infantry battalion uses the rifle company as its basis to generate mission tasks. A rifle company generally consists of a “company headquarters, weapons platoon and three rifle platoons” (U.S. Marine Corps. 2015, 5-7). The structure of the platoon is depicted in Figure 3.

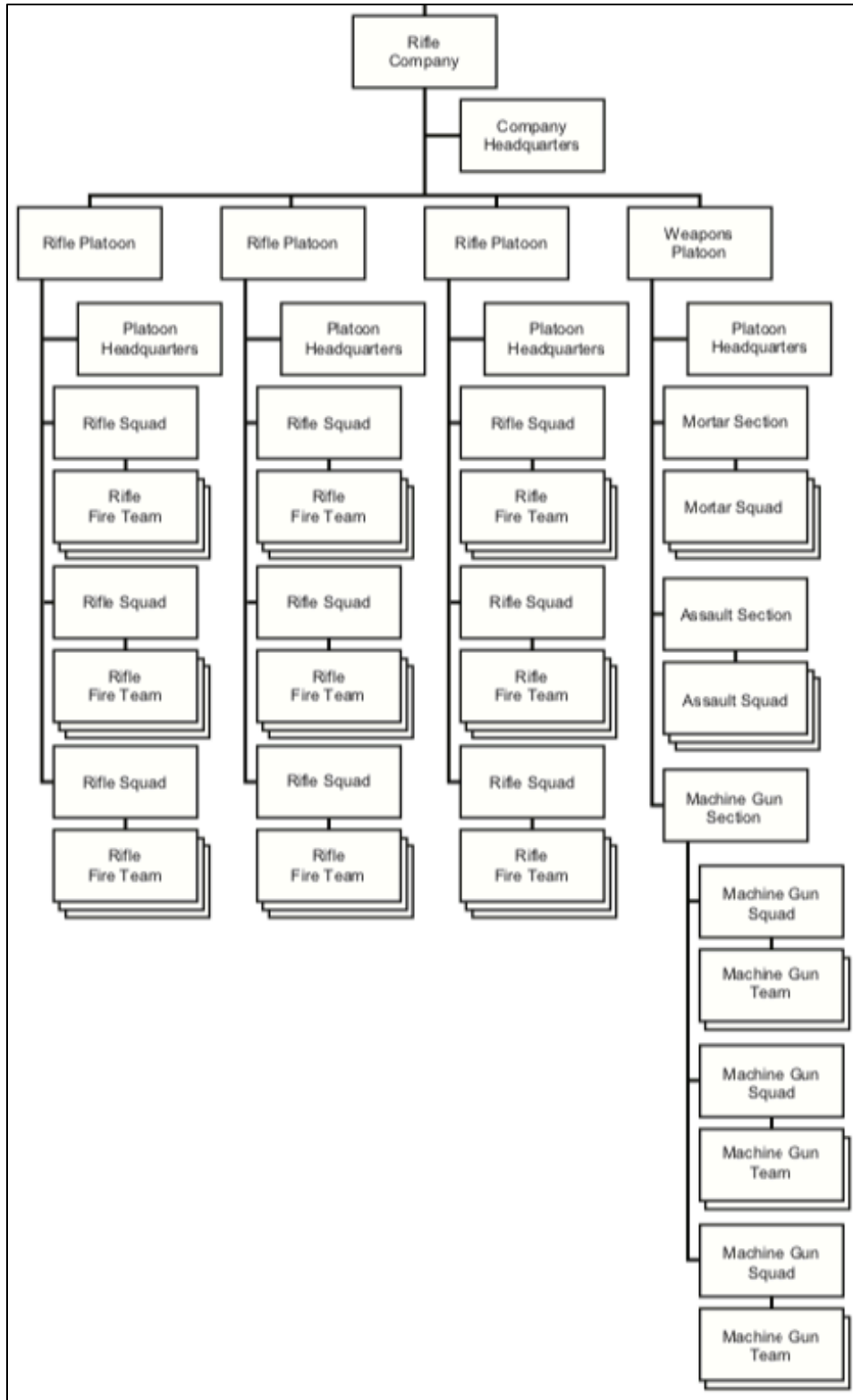

Figure 3. General Organization of a Marine Corps Rifle Company. Adapted from U.S. Marine Corps (2015).

An infantry battalion's rifle company operates as a maneuvering element for the battalion and may conduct independent operations. The Marine Corps Reference Publication 1-10.1 (U.S. Marine Corps 2015) *Organization of the United States Marine Corps* lists the general assignment of a rifle company as:

- Planning, coordinating, and directing the employment of the rifle platoon and attachments to conduct fire and maneuver.
- Planning, coordinating, and directing the employment of the weapons platoon to provide organic direct and indirect fires in support of the company's SOM (scheme of maneuver).
- Planning, coordinating, and conducting ground combat operations and type operations, as directed, across a range of military operations in any expeditionary environment. (U.S. Marine Corps 2015)

Each rifle platoon generally has a platoon headquarters and three rifle squads. Figure 4 depicts the structure of a rifle squad. Each rifle squad generally consists of 13 marines lead by a squad leader and three fire teams (U.S. Marine Corps 2019b).

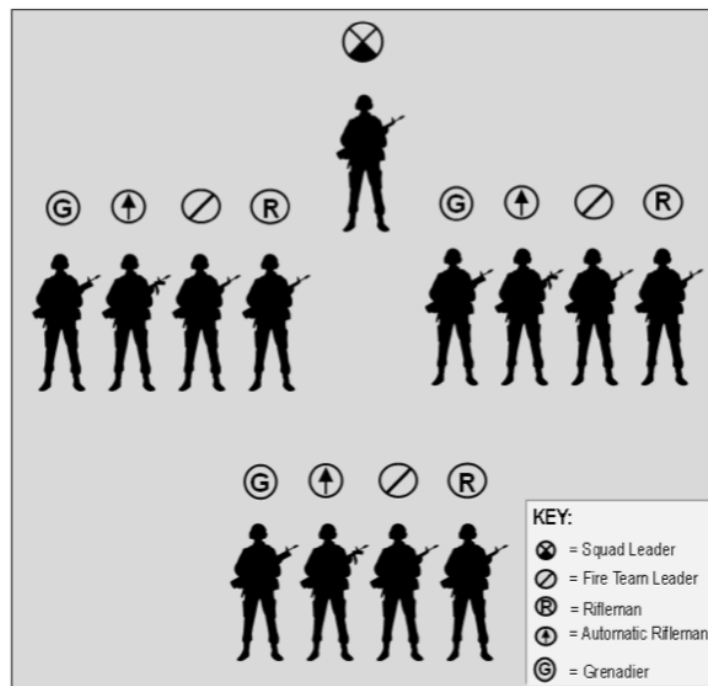

Figure 4. Marine Rifle Squad. Source: U.S. Marine Corps (2019b).

2. USMC Rifle Squad Offensive Operations

The Marine Corps Interim Publication 3-10A.4i (U.S. Marine Corps 2019b) *Marine Rifle Squad* describes tactics, techniques and procedures employed by a rifle squads and the Marine Corps Warfighting Publication (U.S. Marine Corps. 2018a) *Military Operations on Urbanized Terrain (MOUT)* gives additional doctrine guidance as today's Marines are deployed to conflict areas located in or near large urban environments. These references will be useful in understanding how Marine Corps units operate and in developing a vignette to model.

Marine Corps doctrinal publication MCDP 1 (*Warfighting*), describes maneuver warfare as “ a warfighting philosophy that seeks to shatter the enemy’s cohesion through a variety of rapid, focused and unexpected actions which create a turbulent and rapidly deteriorating situation with which the enemy cannot cope” (U.S. Marine Corps 2018c, 4-4). The (U.S. Marine Corps 2019b) divides the squad’s offensive maneuver in five steps consisting of “preparation, conduct, consolidation and reorganization, exploitation and pursuit” (U.S. Marine Corps 2019b, 48). This study will focus on the initial three for a single event as exploitation and pursuit are suited for prolonged campaigns. For the purposes of this thesis, the following definitions are used:

- Preparation: Initiates upon receiving a warning order. Actions during this step include moving to the designated assembly area, reconnaissance and rehearsals. This step concludes once forces move past the line of departure.
- Conduct: Initiates once the squad starts moving towards a designated assault position. The final assault initiates the final assault position until the final coordination line is reached. Fire is either ceased and or shifted to supporting fire.
- Consolidation and reorganization: Initiates when the squad regroups and replenishes supplies. The squad maintains knowledge of enemy location, establishes security/defensive position, self-assessment, receives additional updates/orders and prepares for follow-on tasking. (U.S. Marine Corps 2019b)

The Marine Corps uses six basic forms of offensive maneuvers to gain an advantage over its enemy. Each maneuver, “frontal attack, flanking attack, envelopment, turning movement, infiltration and penetration” (U.S. Marine Corps 2019a, 9-9), has a specific purpose and is chosen by the MAGTAF commander to accomplish a mission. This study will focus on a penetration maneuver to further develop a vignette.

The U.S. Marine Corps describes a penetration as “form of maneuver in which an attacking force seeks to rupture enemy defenses on a narrow front to disrupt the defensive system” (2019a, 9-16). The objective of a penetration maneuver, depicted in Figure 5, is to create weakened enemy flanks open for additional attack. Penetrations maneuvers concentrate overwhelming force to overrun and deeply rupture a position. The maneuver continues by widening the penetrated gap for additional units as the objective is seized.

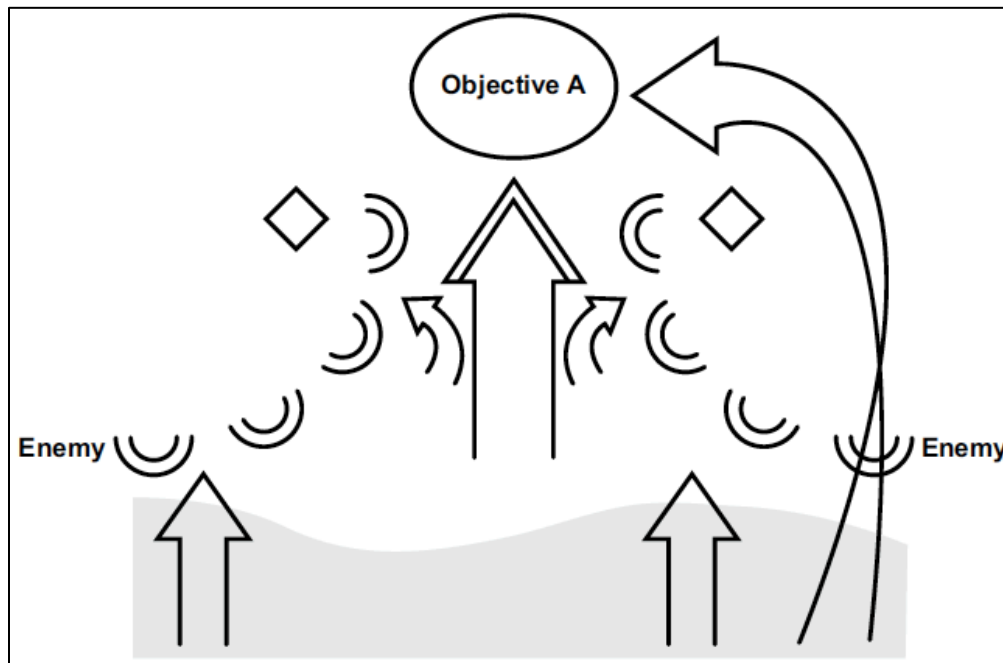

Figure 5. Penetration. Source: U.S. Marine Corps (2019a).

The rapid advancement of penetration leaves an inherent risk of the force being attacked from its flank by the enemy. Units must secure the shoulders of the penetration along with using the ability to rapidly mass fire support. Mobile mortars, mechanized units and especially aviation forces are well suited to provide fire support for a penetration maneuver.

Fire support assets aid troop movement by enhancing the effects of unit fire and a unit's ability to maneuver. The additional fire support capability increases the fighting power of a numerically inferior unit. Fire support is generally well planned and coordinated in advance of the mission. Fire support helps to mask troop advancement even prior to reaching final assault positions. Prior to a mission all unit members should know what fire support is available during the movement period and what pre-planned assaults have already occurred (U.S. Marine Corps 2019b).

3. USMC Communication

Radios are a vital to the Marines as they are often the only means of communication a squad has with friendly units. Radios aid in establish command and control, needed to conduct fire support, call for reinforcements or casualty evacuations. A USMC rifle squad may use a variety of vehicle mounted, pack or handheld radios throughout their mission. The equipment list presented in Table 1 will serve as a starting point for the definition of the physical architecture and simulation objects created in the operational model (U.S. Marine Corps 2019b).

Table 1. Infantry Battalion Equipment List. Source: Marine Corps Combat Development and Integration (2018).

TAM Number	Item	Quantity		
		Infantry Battalion (Each)	Headquarters Company Infantry Regiment (Each)	
A0662	FMF end-user computer	13	13	
A0815	Heliport lighting set	1	1	
A1530	Radar transponder beacon, AN/PPN-19	2	4	
A1815	Radio set, AN/GRC 160	21	43	
A1930	Radio set, AN/MRC 110A	5	5	
A1935	Radio set, AN/MRC 138A	3	5	
A1957	Radio set, AN/MRC 145	5	7	
A2030	Radio set, AN/PRC 68A	94	6	
A2050	Radio set, AN/PRC 119	72	21	
A2051	Radio set, position location reporting system (PLRS)	15	6	
A2065	Radio set, AN/PRC 104(B)	5	5	
A2069	Radio set, VHF, AN/PRC 113	5	2	
A2070	Radio set, PRC 119	58	11	
B0730	Generator set, 3 kW, 60 Hz, MEP 016B	1	2	
B1650	Refrigeration unit, 100 ft ³	2	2	
D1002	Truck, ambulance, two litter, 1/4 ton, HMMWV, M1035	2	1	
D1016	Truck, cargo, 1 1/4 ton, diesel, 4 x 4, M1008	4	3	
D1158	Truck, utility, cargo troop carrier, 1 1/4 ton, M998	27	12	
D1159	Truck, utility, armament carrier, M1043	10		
E0892	Launcher, grenade, 40 mm, M203	107	0	
E0310	Dragon day/night tracker	12	0	
E0915	Launcher, assault rocket, 83 mm, MK153 (SMAW)	18	0	
E0935	TOW launcher	8		
E0960	Machine gun, light squad, M249	81	6	
E0980	Machine gun, .50 cal	6	0	
E0980	Machine gun, 7.62 mm, 240G		29	2
E0994	Machine gun, 40 mm, MK14	11	8	
E1065	Mortar, 60 mm, M224	9	0	
E1090	Mortar, infantry, 81 mm, M252 B	0		
H2045	Antenna, RC292	12	15	
H2442	Telephone set, TA-1/PT	44	12	
H2443	Telephone set, TA-312/PT	35	36	

III. SCENARIO AND MODEL ARCHITECTURE

This chapter begins with a general overview of the vignette developed by Alisa et al. (2019). The results of that study are used to develop an expanded systems architecture that can serve as the basis for an operational simulation model in ExtendSim.

A. MODEL VIGNETTE

IPOWER is dependent on the user's ability to build an input mission blocks into the program. Vignettes are brief illustrations that describe the operational concept of a mission and help define models. Alisa et al. (2019) created a generic vignette that consisted of a marine rifle squad (BLUFOR) conducting a penetration maneuver against an opposing force (OPFOR). BLUFOR consists of a USMC rifle squad and a platoon commander. The OPFOR was assumed to be a similarly outfitted opponent, at least in numbers. The penetration operation can be interpreted in two major phases consisting of the plan/intel collection phase (Figure 6) and the attack phase.

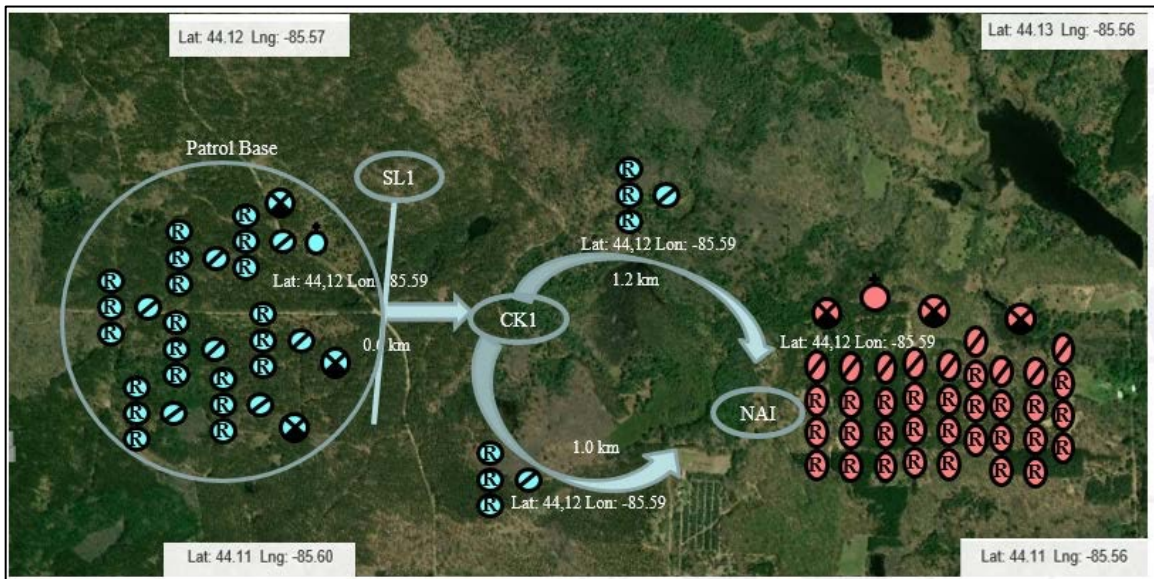

Figure 6. Vignette Phase 1 (Intel Collection). Source: Alisa et al. (2019).

Phase one consists of initial mission planning and intel collection. Initial planning consists of the Marine Air-Ground Task Force Commander deciding on the mission type, location, mission start time and theoretical task durations. The second phase-one activity is to collect area intelligence to gain information on the enemy's activities or terrain. Phase 1 starts when the two fire teams depart the patrol base (Start line 1) and move toward checkpoint one (CK1). Once at CK1, the fire teams separate by taking different paths to a named area of interest (NAI). Once intelligence has been collected, both teams return to base taking the same route. Figure 6 illustrates BLUFOR's movements and gives specific distances.

Phase two (Figure 7) begins with the entire platoon squad (three fire teams and platoon commander) moving from base (SL1) to checkpoint one. From checkpoint one two fire teams move to checkpoint 3 in preparation to conduct fire support from a defensive position. The remaining fire team moves to checkpoint two to conduct the penetration and seize the objective. The penetration attack concludes after OPFOR has retreated and BLUFOR clears the area (Alisa et al. 2019).

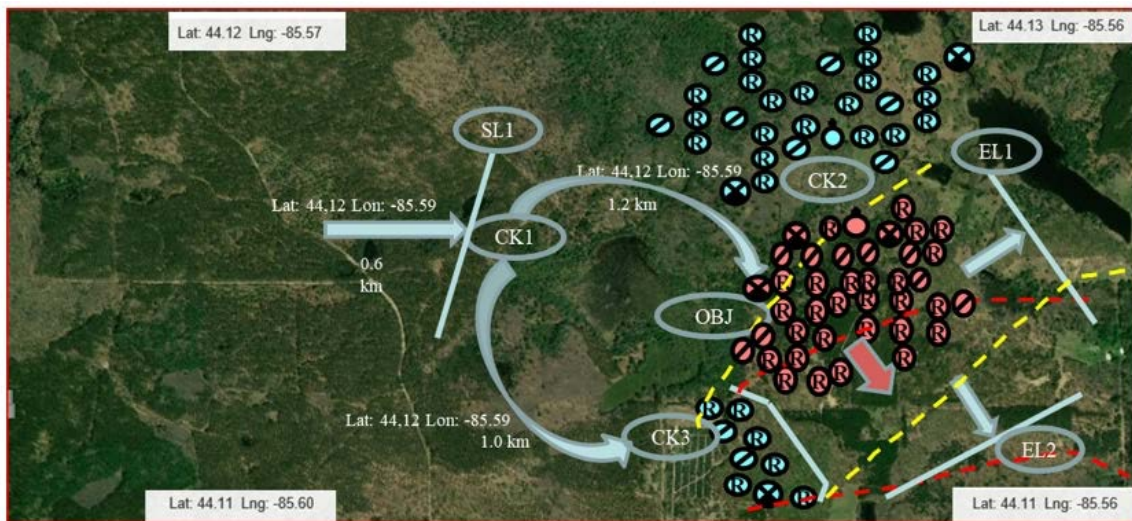

Figure 7. Vignette Phase 2. Source: Alisa et al (2019).

B. MODEL ARCHITECTURE

Using the capstone team's vignette (Alisa et al. 2019), a high-level input-output diagram was created to show the controllable and semi-controllable inputs that will determine the outputs of the ExtendSim model (Figure 8). The objective of this model is to determine the energy consumption of the platoon squad throughout the mission. From the energy consumption the number of batteries needed by the platoon can be determined. How the equipment is used and duration of use is determined by mission objectives, temperature, and the terrain.

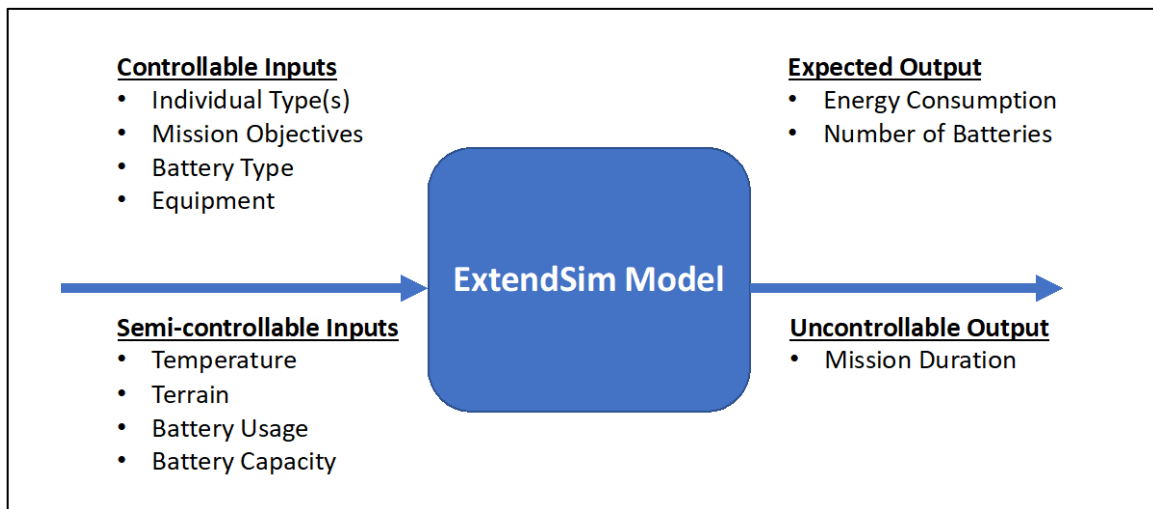

Figure 8. High-Level Input-Output Diagram

The temperature and terrain will also affect the durations of the mission by affecting the platoon's ability to move between locations and as seen in the literature review temperature will affect the perceived battery capacity. The battery type, capacity, charge rate, and usage rates will be controlled/semi-controlled inputs. The model tracks and outputs the energy consumption of the specific equipment used by individual type (Figure 9). The individual types consist of one platoon commander, one squad leader, three fire team leaders and nine riflemen.

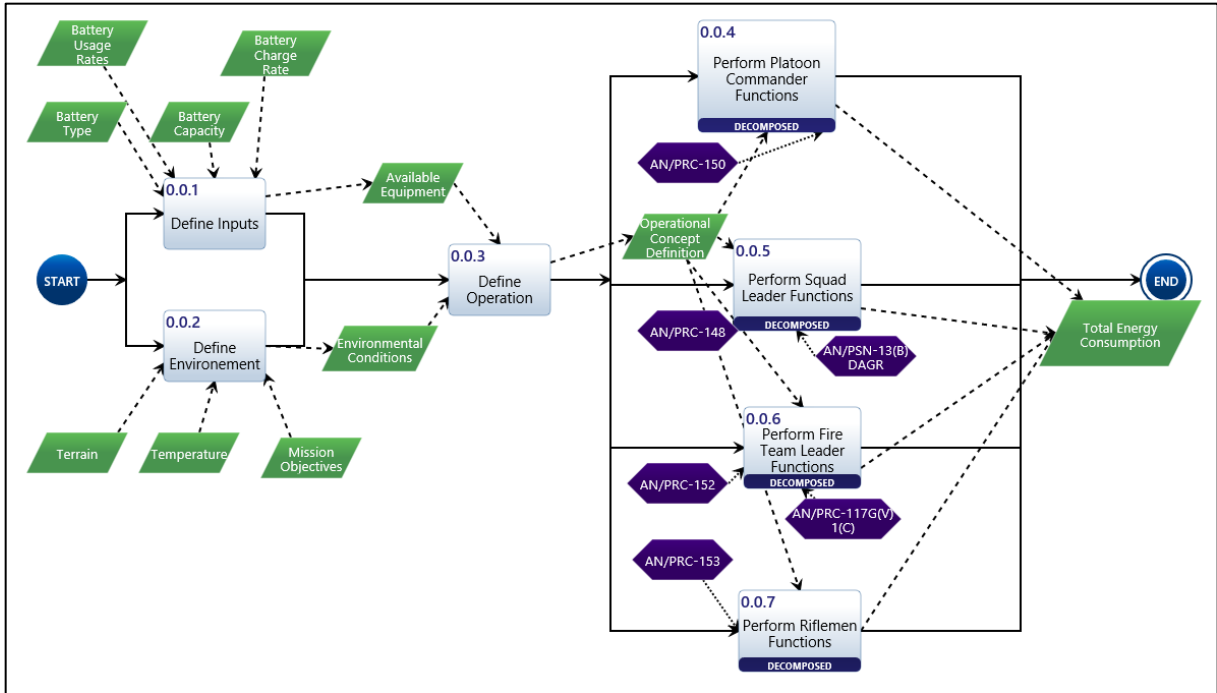

Figure 9. High-Level EFFBD

The (Marine Corps Combat Development and Integration 2018) infantry battalion equipment list, Table 1, shows the apportion of the equipment that an infantry battalion may use. It does not list the specific equipment to individuals within the unit. Assumptions were made in assigning equipment to individual types for the model based on the radio type and intended purpose. Table 2 shows the equipment assigned to each individual type. Radios with long range transmitting and receiving capabilities were assigned to the platoon commander and squad leader. Smaller portable radios were given to the squad team members assuming all members would be equipped with a radio. This model mainly focuses on radio usage throughout the mission, but the model can also be used to determine energy usage of different battery-operated equipment. To demonstrate the versatility the AN/PSN-13 Defense Advanced GPS Receiver (DAGR) was assigned to the squad leader.

Table 2. Model Equipment List

Operator	Equipment Type	Equipment Name
Platoon CMDR	Portable Radio(s)	AN/PRC-150C Radio Set
Squad Leader	Portable Radio(s)	AN/PRC-148
	Navigation	AN/PSN-13(B) DAGR
Fire Team Leaders	Portable Radio(s)	AN/PRC-152
		AN/PRC-117(V)1C Radio Set
Riflemen	Portable Radio(s)	AN/PRC-153 (Motorola)

The mission described by (Alisa et al. 2019) was decomposed into four essential functions (Execute Planning, Execute Observation, Execute Attack and Secure Area) that the rifle squad must complete to accomplish the mission (Figure 10). All individual types go through the same function tasks throughout the model. The model tracks the energy consumption during each activity, accumulates the total energy consumption of each individual and equipment type at the end of the model. The energy consumption is then used to determine the quantity of battery packs required for each individual type. The subsequent sections provide additional detail regarding each phase of the operation.

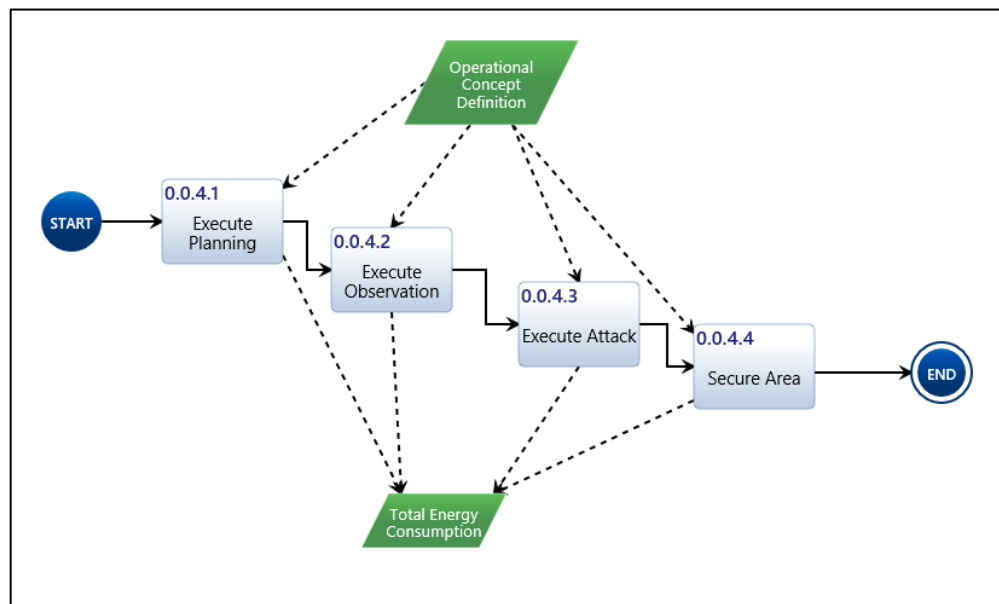

Figure 10. Platoon Commander EFFBD

1. Plan

Three essential sub-functions occur at time zero of the model. The plan phase (Figure 11) is defined as: Select the area of operation (AOR), make operational decisions, select equipment functions determine the operational, system and environmental variables that will affect the output of total energy consumption.

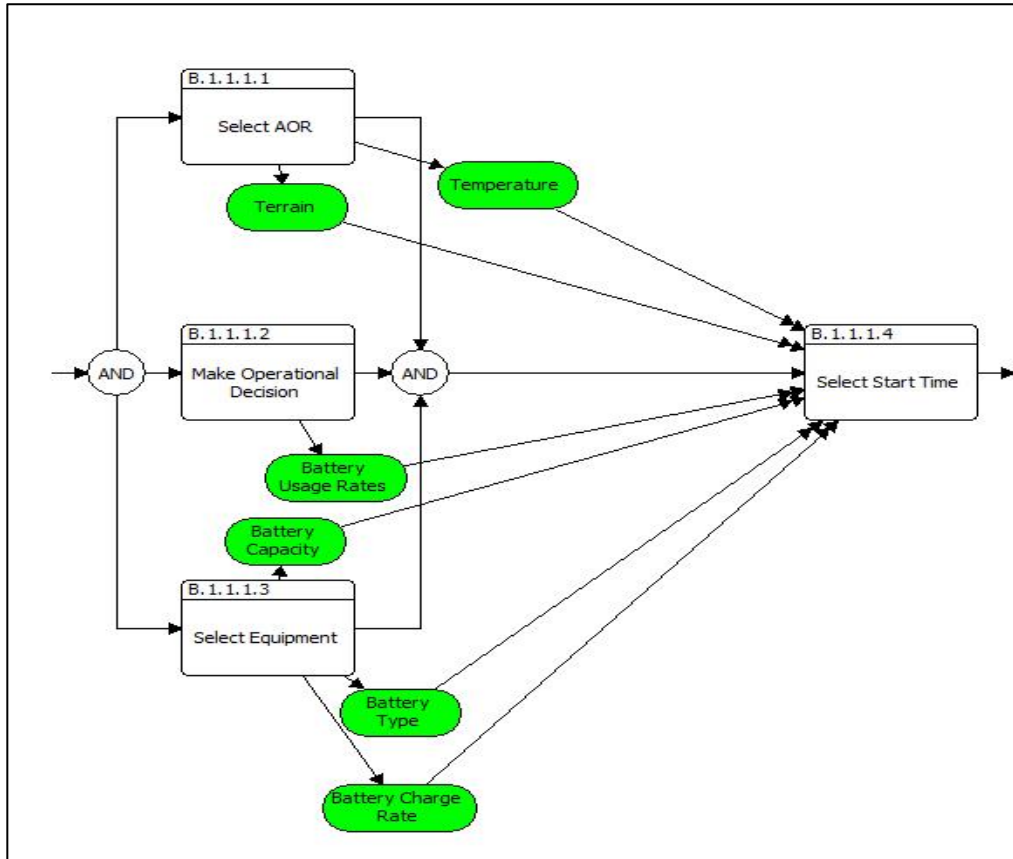

Figure 11. Plan Functional Flow Block Decomposition

IPOWER incorporates geographical location to determine a temperature to incorporate into its energy consumption calculations. This model assumes temperature and terrain are two significant environmental factors that will affect the duration of the mission and battery performance. It is not unreasonable to assume the terrain will also affect the efficiency a rifle platoon is able to move. This model applies a terrain multiple to simulate the rifle squad encountering various terrains. It is assumed this effect is minimal as the

model uses random number generator using a triangular distribution. The triangular distribution has a base range between 0.6 and 1.0. The peak (most likely value) of the distribution is assumed to be 0.9 . The model generates a value and applies it to each individual type's speed at time zero.

Temperature, as shown in the literature review, affects the batteries ability discharge and in addition this model assumes temperature will affect the speed the rifle squad will be able to traverse the terrain. An efficiency table (Table 3) was created for a range of temperatures recording the data points from the Energy-Power Index (EPI) profile and assumes values for the movement speed efficiency.

Table 3. Efficiency Table

Temp (F)	Battery Capacity Multiplier (EPI)	Movement Multiplier
5	0.75	0.60
14	0.933	0.70
32	0.96	0.80
50	0.971	1.00
77	1.00	1.00
95	0.998	1.00
113	1.002	1.00
131	1.005	0.95

JMP statistical software was used to fit regression plots and determine prediction expressions.

- $EPI = 0.908342846 + 0.0014342955 * Temp + (Temp - 64.625) * ((Temp - 64.625) * -0.00002558)$
- $Movement\ Mult. = 0.7971007054 + 0.0029863941 * Temp + (Temp - 64.625) * ((Temp - 64.625) * -0.00005722)$

The model takes a temperature input, random or controlled, and assigns each individual type a multiplier that affects the battery capacity and squad speed throughout the model.

Operational decisions are made in the planning phase that determine the type of mission, specific tasks the rifle squad will perform through the mission and determines the needed equipment (system variables). The decisions determine how the platoon operates and will affect the usage rates (operational variables) of their equipment. The usage rates for each individual type and equipment are unique to individual type and equipment. Usages rates are further defined into active and standby categories as radios consume higher currents when transmitting. It is assumed the radios are powered on throughout the entire model. The specific tasks that are performed are defined in the vignette and will be covered in the observe, attack, and secure area phases.

2. Observe

The observe phase directly follows the vignette moving the platoon commander, squad leader and two fire teams from base to the initial starting line in preparation to collect intelligence. Figure 12 shows the tasks each fire team will conduct during this phase.

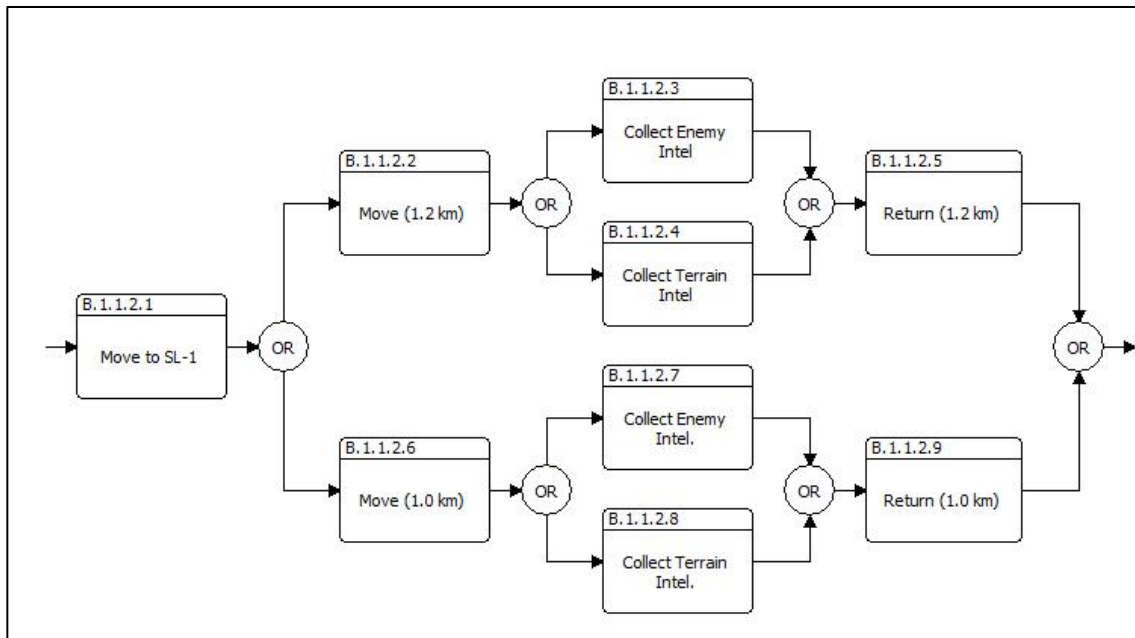

Figure 12. Observe Functional Flow Block Decomposition

The duration of all the move activities are based on speed and distance calculations. The initial move activity block assumes the fire teams are traveling via Humvees. Once the teams reach check point one, the teams split up and are assumed to travel on foot to the named area of interest (NIA). Each team collects intelligence, on the terrain or enemy, based on a duration between two to four hours. A random number generator using a triangular distribution determines the actual duration and is set at time zero of the model. The most likely value for the triangular distribution was set to three hours the values used in Alisa et al. (2019). Once a team has completed collecting intelligence they return to base camp and wait for all platoon squad members before proceeding to the attack phase.

3. Attack and Secure Area

The attack phase begins once all members have returned to base. At this point, the model sends the entire platoon squad (three fire teams) to checkpoint one (Figure 13). All move activity blocks in this phase assume the platoon is moving on foot. The attack is coordinated as depicted in the vignette the model that sends two teams in preparation to conduct support fire and one team moves to conduct the penetration maneuver.

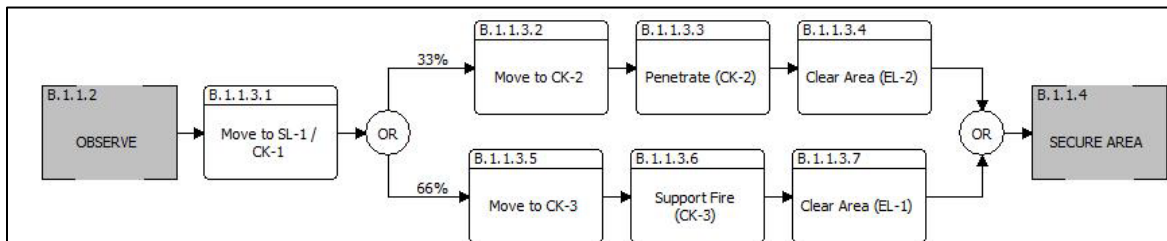

Figure 13. Attack Functional Flow Block Decomposition

The durations of the attack and secure area phases are determined by random number generators using a triangular distribution. Based off Alisa et al. (2019) the most likely value the most likely value was set to two hours, and the model assumes a range of one to three hours. Once the secure area duration has concluded, all final power consumption calculations are conducted as the items (platoon squad members) leave the model.

THIS PAGE INTENTIONALLY LEFT BLANK

IV. MODEL SIMULATION AND ANALYSIS

This chapter begins with a high-level overview of the ExtendSim model and a description of the design of experiment (DOE) created to randomize and replicate controlled model inputs (factors) to make a statistical inference of the behavior of the ExtendSim model. This chapter will continue with brief review of the 2019 system engineering capstone team's experiment (Alisa et al. 2019) and compare their IPOWPER analysis with the results of the ExtendSim DOE. This chapter will also explore, through regression analysis, the factors that contribute the most to the battery usage in the model.

A. DESCRIPTION OF EXTENDSIM MODEL

Following the modeling approach described in MacCalman et al. (2016), this ExtendSim model incorporated the architecture and concepts developed in Chapter III. Figure 14 depicts the high-level functions/tasks (plan, observe, attack and secure) that must be accomplished to complete the mission correlating to what developed in Figure 10. Detailed descriptions of each phase are included in Appendix A.

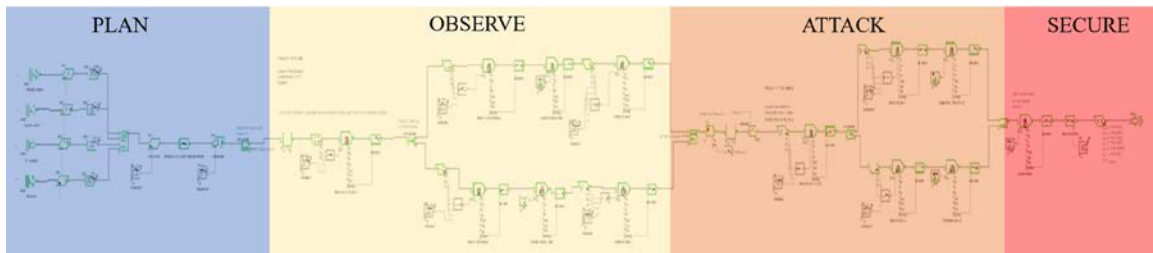

Figure 14. ExtendSim 10 Model

This ExtendSim model's plan phase (highlighted in blue) creates four different item types to represent the members of the rifle squad. The create-blocks produce one platoon commander, one squad leader, three fire team leaders and nine riflemen. The individual types are set using a numeric value to determine which tasks they will perform later in the model. In this phase equipment databases are assigned by individual. The temperature and

terrain effects were modified from random number generators to read from a database to support an experiment design.

The items move through the rest of the model grouped by individual type. It was necessary to represent different fire teams to conform with the vignette established by the capstone team. Select-in-and-out blocks were used to separate the items by individual type allowing only two fire teams, the squad leader and platoon commander to go through the observe phase (highlighted in tan) before the entire squad moved through the attack (highlighted in orange) and secure phases (highlighted in red).

Energy consumption is tracked as an item's attribute and is calculated after each activity-block throughout the model. The Amp-hours used by equipment type is pulled before the items exit the model. The ExtendSim model produces the amp-hours used by individual type and equipment type. The number of batteries needed by equipment type is then calculated by a set of equation blocks shown in Appendix A.

B. EXPERIMENT FACTORS AND RANGES

One of the goals for this thesis was to expand on the analysis that was done by Alisa et al. (2019). The capstone team recommend three IPOWER capability improvements to increase the accuracy of the data reported. The capstone team recommended that IPOWER have a capability to simulate parallel activities, account for environmental factors and account for equipment efficiency. The ability to account for parallel activities was achieved through the model architecture seen in the “observe” and “attack” function flow blocks (Figure 13 and 14). The model also intends to capture the environmental effects of temperature and terrain type. The full list of factors and their ranges used in the DOE are shown in Table 4.

Table 4. List of Experiment Factors

Type	Factor (DOE Input)	Min	Max	Unit
Environmental Variable	Temperature	20.00	120.00	F
	Terrain Multiple	0.60	1.00	%
System Variable	Battery Capacity	1.00	0.70	%
	Humvee Speed	13.40	24.60	m/s
	Troop Speed (Foot)	0.89	2.68	m/s
Operational Variable	Radio Transmission Use			
	Move Phase	0.00	0.20	%
	Intel Collect Phase	0.01	0.40	%
	Attack Phase	0.20	0.60	%

The temperature and terrain are environmental factors that have multiple effects on the model. Temperature affects the battery capacity and will have an effect on the duration of the movement blocks by applying the movement speed multiple discussed in chapter three. A wide experimental temperature range was used to capture temperatures seen by troops in common areas of operation. It is safe to assume that different operational area terrains affect the speed ground forces are able to traverse. The range of terrain multiple will affect the duration of the movement blocks in the model as it simulates different terrain types. The higher the multiple the flatter or smoother the terrain is assumed to limit the effect on the troop/Humvee speed. The reverse affect is assumed with a lower multiple.

The DOE also varies the troop speed (on foot), Humvee speed and battery capacity. Troop speed will directly impact the duration items (squad members) spend in the move activity blocks which may impact the overall energy consumption in the model. Troop foot speed is based off a walking/jog speed between 2 mph and 6 mph. Humvee speed in this operation was assumed to be between 30 mph and 55 mph. From the literature review, the age of a battery is a factor in the battery’s performance. The DOE will vary the battery capacity to show how this affects the number of batteries need to complete the mission. It is assumed that there are no dead batteries and all batteries will be at least 70% of their original capacity.

Different phases of this mission require different amounts of communication. This will vary how often squad members are transmitting on the radios. Radio transmission is defined by the three major activities performed in the model, shown in Table 4. Their maximum and minimum values are estimates of the amount of time they will be used during those phases. It is assumed that radio transmission is significantly higher during the attack phase than during intel collection and troop movement. The radio transmission usage rates defined by (Alisa et al 2019) are inclusive in the ranges for this DOE.

C. DESIGN OF EXPERIMENT

A well-designed DOE is a benefit to any simulation as it allows for the exploration of trade-offs. Rather than using an unknown software algorithm to generate a DOE a design was chosen that was developed at the Naval Postgraduate School (NPS). A Nearly Orthogonal and Balanced (NOB) design was developed by Vieira et al. (2013). The design was built in continuation to the Nearly Orthogonal Latin Hypercube (NLOH) design to decrease pairwise correlation caused by rounding of discrete or categorical factors. Since most of the chosen factors are relatively small numbers, the NOB will help maintain a near-orthogonal design. The NOB design template can be found on the NPS SEED Center website, available at <https://nps.edu/web/seed/software-downloads> (Vieira et al. 2013).

The NOB of was used to build the DOE for this thesis. The template takes the minimum and maximum values of the eight factors listed in Table 4 and defines 512 design points. Figure 15 shows an excerpt of the 512 design points that were imported into the ExtendSim model. Each of the 512 design points were replicated thirty times. Using the central limits theory, a sample size of 30 will sufficiently account for the variability associated with each individual model run. This ultimately resulted in 15,360 simulation runs.

	20	0.6	0.7	0.2	0.01	0	13.4	0.89
	120	1	1	0.6	0.4	0.2	24.6	2.68
	2	4	4	4	4	4	4	4
Record#	Temperature	Terrain Mult	Battery Capacity %	Attack usage Rate	Intel Usage Rate	Move Usage Rate	Humvee Speed (m/s)	Troop Speed (m/s)
1	27.24	0.9773	0.7511	0.5773	0.3222	0.011	23.263	1.2648
2	69.32	0.744	0.9519	0.2697	0.1504	0.0446	19.3616	1.1737
3	56.01	0.9491	0.7123	0.2955	0.0382	0.137	17.3671	1.7342
4	64.81	0.6133	0.9865	0.517	0.2802	0.0477	17.4329	1.5521
5	99.45	0.9937	0.7523	0.2493	0.1222	0.092	20.7863	2.5889
6	120	0.7198	0.9712	0.5859	0.2145	0.065	17.7178	1.6992
7	108.65	0.7753	0.7399	0.2243	0.2619	0.1479	21.0712	1.4785
8	67.16	0.9851	0.7863	0.2822	0.1321	0.0783	21.4438	2.6345
9	33.11	0.69	0.9748	0.5366	0.384	0.1468	21.2466	0.9671
10	63.25	0.6861	0.9871	0.5616	0.1741	0.1112	14.2329	2.1125
11	26.65	0.6039	0.7029	0.2814	0.3023	0.1636	16.6658	1.8883
12	74.21	0.9342	0.754	0.5804	0.3008	0.0239	17.1699	1.7762
13	61.49	0.7511	0.9131	0.5155	0.3428	0.0376	20.3699	1.7307
14	110.8	0.7315	0.8409	0.5413	0.065	0.1104	17.9808	1.7272
15	100.82	0.8834	0.9759	0.3182	0.181	0.0215	21.1151	2.2211
16	97.5	0.9969	0.8521	0.2744	0.1077	0.1847	21.4219	0.89
17	109.82	0.7675	0.7382	0.211	0.258	0.0544	17.6521	1.6396
18	50.72	0.8802	0.9695	0.4575	0.2435	0.1973	21.1808	1.2613
19	39.18	0.9249	0.9049	0.4027	0.0138	0.1538	13.6192	1.0161
20	20	0.6712	0.8016	0.2282	0.097	0.1366	20.6767	2.5679
21	83.21	0.9906	0.9654	0.5796	0.0596	0.0716	17.6959	1.6957
22	29.78	0.672	0.7687	0.4951	0.2725	0.0548	14.4959	2.6625
23	26.07	0.6102	0.9055	0.2689	0.3603	0.1483	21.2247	1.5065
24	78.51	0.7299	0.8838	0.5914	0.4	0.0153	17.7397	1.7622
25	70.49	0.6838	0.7434	0.4364	0.1619	0.0137	20.4137	1.4575
26	87.51	0.874	0.7552	0.2039	0.313	0.0008	16.6	1.1597
27	92.02	0.7769	0.9483	0.4701	0.3527	0.0779	21.9479	2.0915
28	76.16	0.7534	0.902	0.3025	0.1764	0.1084	20.2384	0.9986
29	77.73	0.6642	0.717	0.5115	0.3115	0.0975	20.8521	1.6782

Figure 15. NOB Design (First 29 Design Points)

D. DATA ANALYSIS (1-TO-1 COMPARISON)

One of the goals of this thesis is to compare the data analysis conducted by Alisa et al. (2019) with the results of this thesis ExtendSim model. The team focused on the AN/PRC-153 (handheld radio) as it had the highest usage throughout the mission. The team’s analysis consisted of four simulations assessing the capability of IPOWER. The baseline model consisted of 15 IPOWER activity blocks, each with a defined transmit usage percentage set by the operator (capstone team). In their baseline simulation a single AN/PRC-153 required 3.3 batteries. Their first variation increased the transmit usage by 50% for each activity block. This resulted in the AN/PRC-153 requiring 4.5 batteries. Variation two increased the battery capacity of the radios by 50% in addition to the increased usage rate. This resulted in the AN/PRC-153 needing 3.5 batteries to complete the mission. Variation 3 adjusted the durations of multiple activities, none uniformly, causing there to be no change to the batteries needed from the baseline scenario (Alisa et al. 2019).

The NOB design provides a much broader and more robust experiment design, creating 512 design points or scenario variations versus only looking at 4 variations. JMP statistical software was used as means to conduct analysis, provide visuals of the data and provide a means to analyze data through regression. JMP was used to create a histogram and show a statistical summary (Figure 16) of the number of batteries required for the AN/PRC-153 over the 512 design points. This ExtendSim model groups the total number of batteries needed by equipment instead of by individual unit. Over the 512 design points the riflemen (nine total riflemen) required a mean of 22.83 battery packs to complete the mission. Since it is impractical to carry only 0.83 of a battery, we will assume the model requires 23 batteries. This would equate to 2.55 packs per radio/person or rounded to 3 battery packs per radio/person.

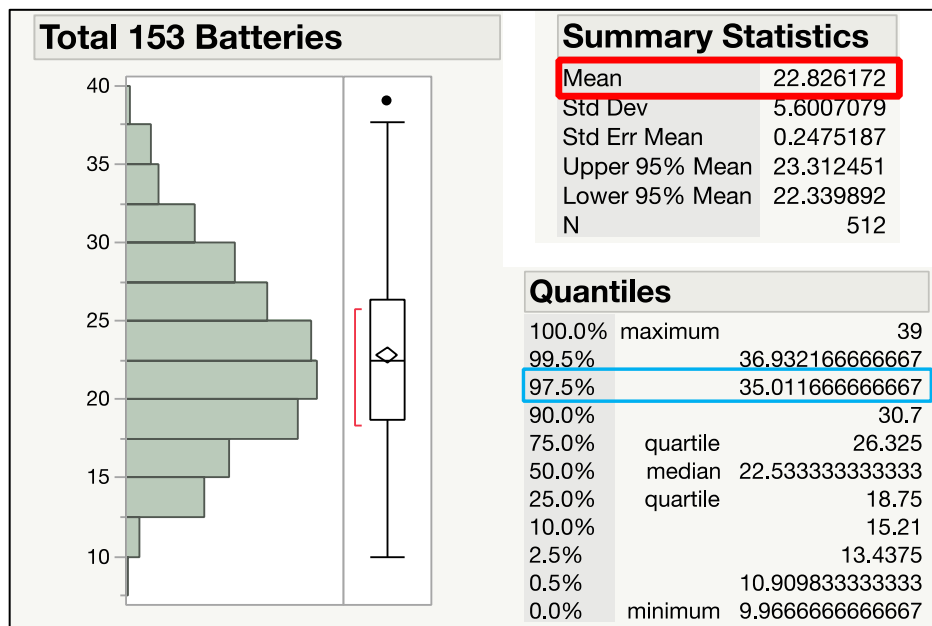

Figure 16. Total AN/PRC-153 Batteries Histogram and Data Summary

The capstone team's baseline analysis, variations 1 and 2 would equate to 29.7 batteries, 40.5 batteries and 31.5 batteries required for a total of 9 riflemen. Their results are shown to fall on the higher end of the distribution created by JMP. The capstone teams baseline model and variation 2 fall within the 97.5% quantile while variation 1 exceeds the

maximum value of the distribution. This could be due to the specific variation from increasing usage rates of all activities by 50% may be considered unlikely to occur. The model gives a median value of 22.5 batteries or a rounded value of 3 per riflemen. Rounding the capstone teams result this is a reduction of 1 whole battery and reduction of 2 batteries from their variation 1. Even though this seems like a minimal reduction, it prevents ground soldiers from caring extra weight. This also would also result in fewer batteries required to outfit platoons which inevitably save the USMC money and help maintain their war reserve stock.

E. REGRESSION ANALYSIS

An advantage of building a stochastic simulation model, explored using an efficient experimental design, is the ability to identify the design decisions that have the largest impact on model results. Regression analysis will explore the effects of independent variables (factors from Table 4) and their interactions on the dependent variables (model outputs). This regression analysis can be used to find trends in the data, allowing for future prediction models and possibly provide better capability to IPOWER's prediction software.

1. Total AN/PRC-153 Batteries

Instead of conducting an overall least squares regression including all factors and 2nd order interactions, it is possible that a model with fewer variables will be able to provide an adequate prediction while using fewer variables. JMP's stepwise regression was used to evaluate the data. The software evaluates multiple models by incrementally adding variable terms in the model. JMP uses the minimum Bayesian Information Criterion (BIC) to choose the best model with a limited set of parameters. A stepwise regression was conducted to find an appropriate model for the total AN/PRC-153 batteries needed. The results are shown in Figure 17.

Step History									
Step	Parameter	Action	"Sig Prob"	Seq SS	RSquare	Cp	p	AICc	BIC
1	Attack usage Rate	Entered	0.0000	10232.92	0.6384	11671	2	2701.47	2714.13
2	Battery Capacity %	Entered	0.0000	2677.302	0.8054	6047.2	3	2386.19	2403.07
3	Intel Usage Rate	Entered	0.0000	2380.947	0.9540	1046.4	4	1650.2	1671.27
4	Temperature	Entered	0.0000	289.9184	0.9721	439.18	5	1396.71	1421.97
5	(Battery Capacity %-0.85)*(Attack usage Rate-0.4)	Entered	0.0000	115.0991	0.9792	199.34	6	1246.7	1276.14
6	Move Usage Rate	Entered	0.0000	31.25354	0.9812	135.67	7	1198.27	1231.89
7	(Temperature-70)*(Attack usage Rate-0.4)	Entered	0.0000	17.93683	0.9823	99.978	8	1168.95	1206.73
8	(Battery Capacity %-0.85)*(Intel Usage Rate-0.205)	Entered	0.0000	12.4136	0.9831	75.894	9	1148.12	1190.06
9	Troop Speed (m/s)	Entered	0.0000	12.56453	0.9839	51.494	10	1125.92	1172.01
10	Terrain Mult	Entered	0.0003	6.837619	0.9843	39.126	11	1114.3	1164.53
11	(Temperature-70)*(Intel Usage Rate-0.205)	Entered	0.0012	5.220664	0.9846	30.157	12	1105.68	1160.05
12	(Move Usage Rate-0.1)*(Troop Speed (m/s)-1.785)	Entered	0.0010	5.279559	0.9849	21.063	13	1096.71	1155.2
13	(Battery Capacity %-0.85)*(Move Usage Rate-0.1)	Entered	0.0125	3.010456	0.9851	16.738	14	1092.41	1155.01
14	(Terrain Mult-0.8)*(Humvee Speed (m/s)-19)	Entered	0.0230	3.598863	0.9854	13.176	16	1088.89	1159.7
15	(Attack usage Rate-0.4)*(Humvee Speed (m/s)-19)	Entered	0.1014	1.270128	0.9854	12.507	17	1088.26	1163.16
16	(Attack usage Rate-0.4)*(Intel Usage Rate-0.205)	Entered	0.1154	1.169531	0.9855	12.05	18	1087.84	1166.83
17	(Battery Capacity %-0.85)*(Humvee Speed (m/s)-19)	Entered	0.1357	1.047555	0.9856	11.848	19	1087.7	1170.75
18	(Battery Capacity %-0.85)*(Troop Speed (m/s)-1.785)	Entered	0.1499	0.973364	0.9856	11.803	20	1087.71	1174.83
19	(Terrain Mult-0.8)*(Move Usage Rate-0.1)	Entered	0.2248	0.690591	0.9857	12.352	21	1088.36	1179.53
20	(Intel Usage Rate-0.205)*(Troop Speed (m/s)-1.785)	Entered	0.2924	0.519235	0.9857	13.261	22	1089.39	1184.61
21	(Temperature-70)*(Humvee Speed (m/s)-19)	Entered	0.3241	0.455515	0.9857	14.304	23	1090.57	1189.83
22	(Attack usage Rate-0.4)*(Move Usage Rate-0.1)	Entered	0.3298	0.444936	0.9858	15.369	24	1091.79	1195.07
23	(Terrain Mult-0.8)*(Intel Usage Rate-0.205)	Entered	0.3887	0.348183	0.9858	16.637	25	1093.22	1200.53
24	Best	Specific	.	.	0.9851	16.738	14	1092.41	1155.01

Figure 17. JMP Stepwise Regression Analysis of the Total AN/PRC-153 Batteries

The results of stepwise regression present 23 candidate regression models with an increasing number of variables. Based on the BIC criteria, step 24 is identified as the preferred model (13 total factors, highlighted in blue). The RSquare values of subsequent models show little increase in their RSquare values. Based on the results of the stepwise regression, least squares regression was conducted and evaluated using an actual by predicted plot. This plot offers a graphical assessment of how well the raw data fits the prediction expression, shown in Figure 18. If the prediction expression was a perfect fit to the actual data, the plot would show a perfect linear line of data points.

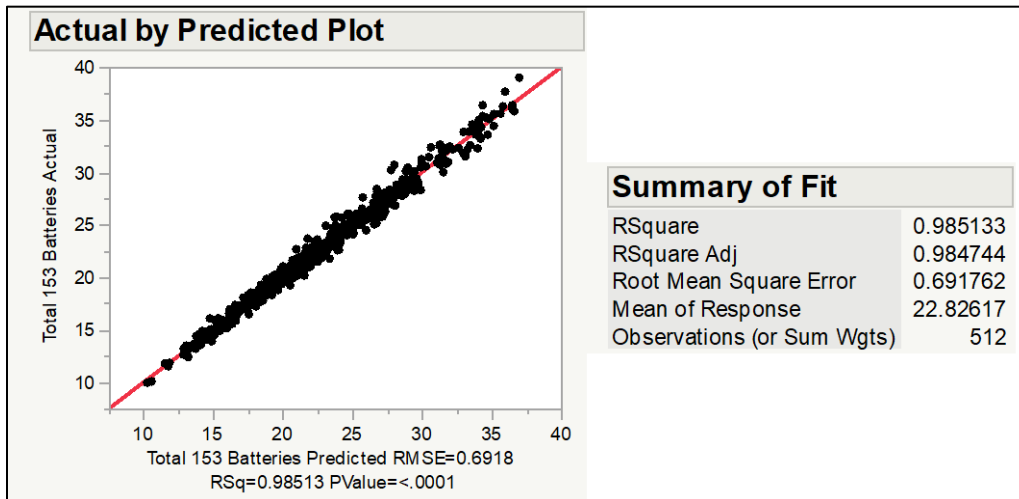

Figure 18. Total AN/PRC-153 Batteries Actual by Prediction Plot and Summary of Fit

The prediction plot shows that the regression model is an excellent fit for the data. The effects summary (Figure 19) shows the significant independent factors and interactions that formed the model. The summary lists the variables in descending order of impact on the model and illustrated using the histogram. Notice only seven out of the eight independent factors from Table 4 are used in this model. The speed the rifle squad travel by Humvee was not a significant factor in this model. The Humvee speed variable does not appear until the 14th step (Figure 17) as an interaction with the terrain multiple.

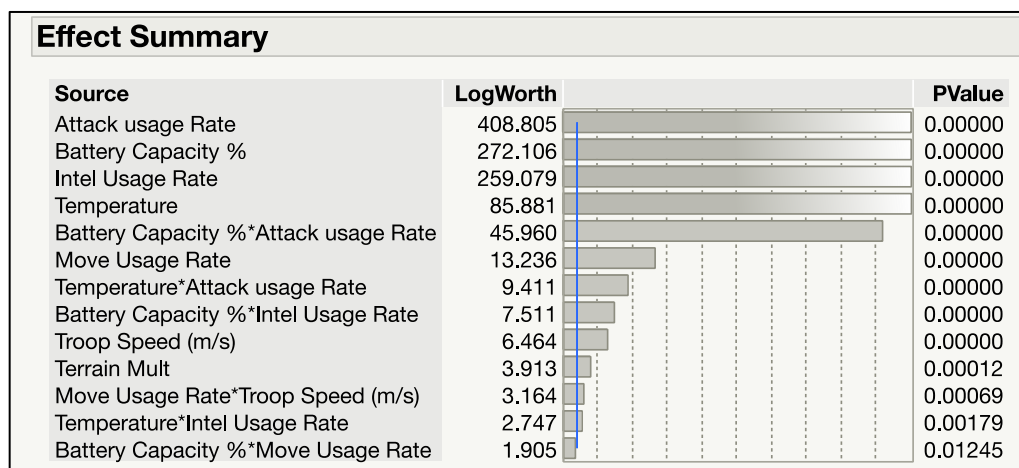

Figure 19. Total AN/PRC-153 Batteries Effects Summary Shows Factor Significance

2. Partition for Total AN/PRC-153 Batteries

JMP's ability to partition the data can be used as another method to evaluate variation due to independent variables. JMP's partitioning segments data categorically by factor creating a hierarchal breakdown of factors that can be used to explain the model. The hierarchy can then function as a decision tree based of the factors from Table 4. By default, JMP will optimize the partitioning of the data to increase the model's RSquare value. JMP's default initial analysis (Figure 20) consisted of the attack usage rate being decomposed by the intel usage rate and battery capacity on the next level.

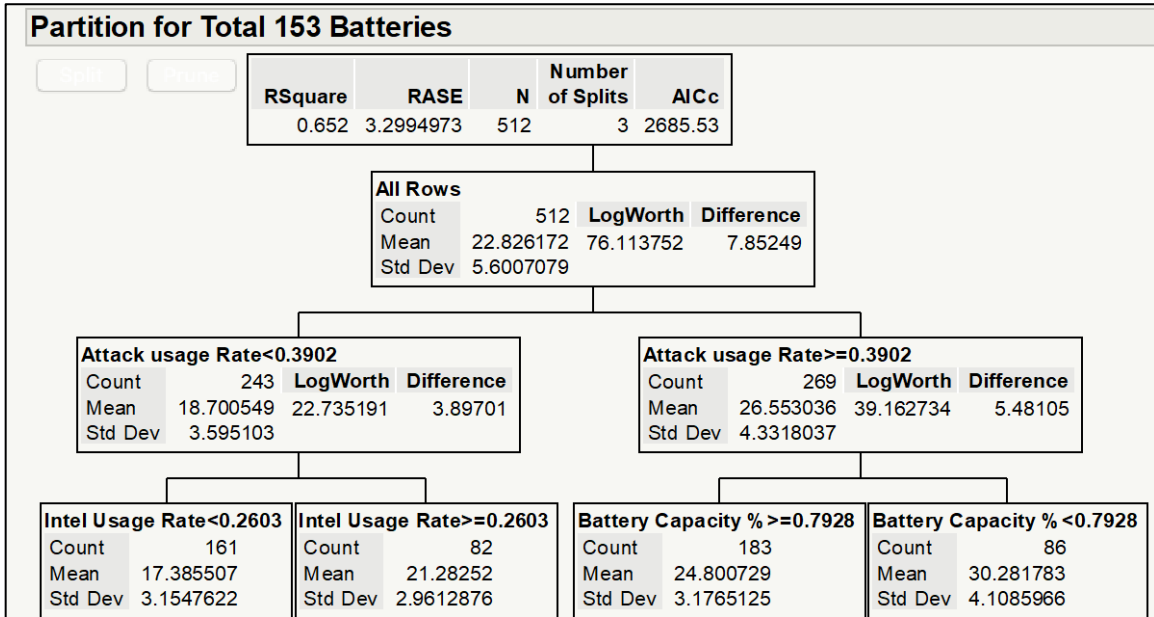

Figure 20. JMP Optimal (default) Partition of the Total AN/PRC-153 Batteries

This optimized partition was used as reference to compare how well subsequent models explain the data. It should be intuitive to the reader that the frequency of radio usage will affect how many batteries are needed for the mission. Since the attack usage rate is the most significant variable in the model, shown in Figure 20, it is an appropriate factor for the first level of decomposition. By default, JMP decomposes the attack usage rate with the intel usage rate and battery capacity which provides the best representation of the

data but offers little actionable guidance when making a comparative decision of the same level. It is beneficial to see how the battery capacity percentage affects the number of batteries needed when the attack usage rate is above and below 0.39. Changing JMP's default partition reduces the RSquare value to 0.623, shown in Figure 21.

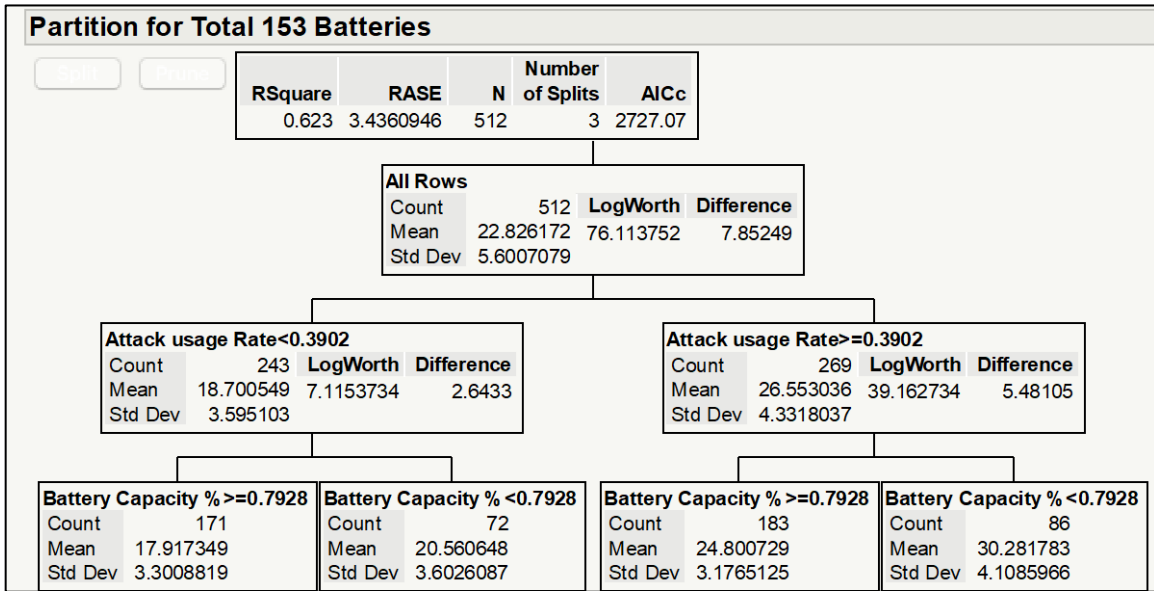

Figure 21. Partition of Total AN/PRC-153 Batteries Using the Attack Usage Rate and Battery Capacity

Setting the battery capacity partition at 0.79 % shows an equal comparison of the number of batteries required when attack usage rate is above and below 39%. The hierarchy shows a mean of 26.5 batteries required when usage is greater than or equal to 39% of the phase duration. Additionally, variation in initial battery capacity affects this outcome. When usage is greater than or equal to 39% and initial battery capacity is greater than or equal to 79.3% the mean for batteries required is equal to 24.8. The mean increases to 30.3 when the initial battery capacity is less than or equal to 79.3%. When the attack usage rate is less than or equal to 39% the mean decreases to 18.7 batteries required. Variation in the initial battery capacity also affects this outcome. When usage is less than or equal to 39% and initial battery capacity is greater than or equal to 79.3% the mean for batteries required is equal to 17.9. The mean increases to 20.5 when the initial battery capacity is less than or

equal to 79.3%. In summary, here we see an increase of two to five batteries required when the initial battery capacity is less than 79.3%.

It may be hard for mission planners to estimate usage rates during a mission, as it is shown by this model that they are primary factors in predicting the number of batteries required. It is most likely the predicted environmental temperature will be known prior to an engagement. From the literature review, temperature and age of the battery affects its state of charge. Figure 22 was created show how only battery capacity and temperature affect the model.

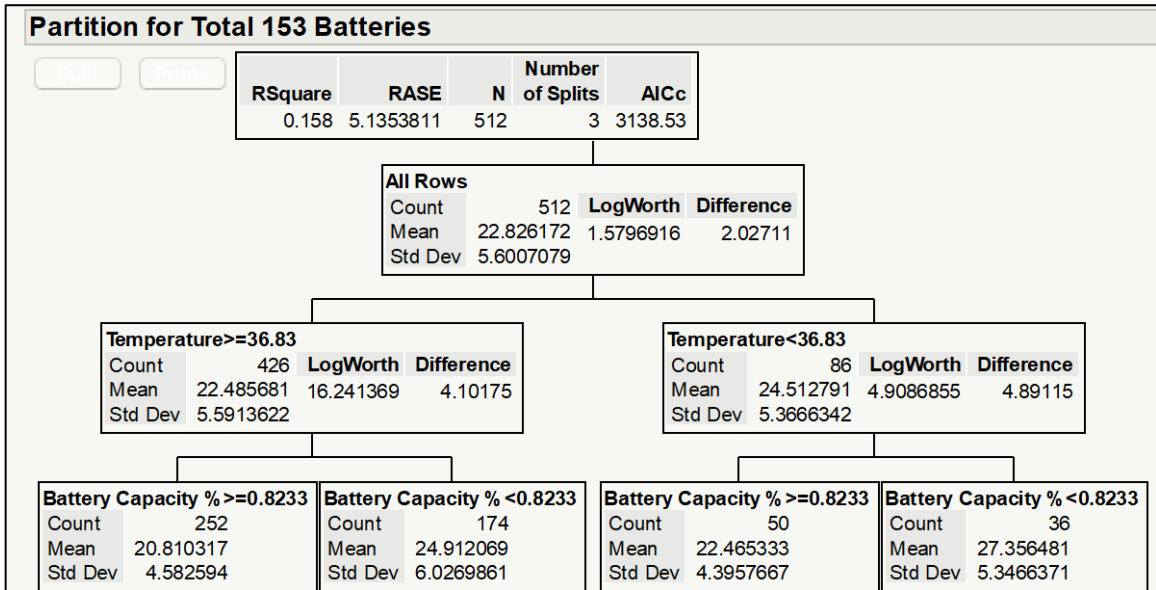

Figure 22. Partition of Total AN/PRC-153 Batteries Using Battery Capacity

This partition only has an RSquare of 0.158, accordingly decision makers should also consider the potential impact of other factors. However, insights can be gained regarding initial planning decisions. It shows an increase in the number of batteries required when temperatures drop below 36.83 degrees Fahrenheit. In these low temperature situations, when the battery capacity is less than 82% the mean increases to 27.4 compared to 22.5 batteries required with a battery capacity greater than 82%. If mission planning included cold weather operations, this hierarchy would show the need to bring extra batteries especially if their state of charge is not verified. A similar insight exists for high

temperature (above 36.83 degrees Fahrenheit) situations. When the battery capacity is less than 82% the mean increases to 24.9 compared to 20.8 batteries required with a battery capacity greater than 82%. Note that in the high and low temperature situation, batteries expected to have less than 82% of their total capacity necessitate an additional four or five batteries, respectively, to complete the operation.

3. Total AN/PRC-153 Amp-Hours

It is worth exploring if the same factors have an effect on the total Amp-hours consumed by the nine riflemen. A stepwise regression was conducted, using the minimum Bayesian Information Criterion, to find the best model for the total AN/PRC-153 Amp-hours consumed, shown in Figure 23.

Step History									
Step	Parameter	Action	"Sig Prob"	Seq SS	RSquare	Cp	p	AICc	BIC
1	Attack usage Rate	Entered	0.0000	32629.28	0.7980	12972	2	2882.7	2895.37
2	Intel Usage Rate	Entered	0.0000	7754.695	0.9877	315.27	3	1452.12	1469
3	Move Usage Rate	Entered	0.0000	99.81285	0.9901	154.34	4	1340.94	1362.02
4	Troop Speed (m/s)	Entered	0.0000	42.90274	0.9912	86.313	5	1285.41	1310.67
5	Terrain Mult	Entered	0.0000	19.77074	0.9917	56.04	6	1258.58	1288.02
6	(Terrain Mult-0.8)*(Move Usage Rate-0.1)	Entered	0.0000	18.14612	0.9921	28.419	7	1232.61	1266.23
7	(Move Usage Rate-0.1)*(Troop Speed (m/s)-1.785)	Entered	0.0005	7.629423	0.9923	17.966	8	1222.43	1260.21
8	(Battery Capacity %-0.85)*(Intel Usage Rate-0.205)	Entered	0.0256	4.565373	0.9924	14.513	10	1219.12	1265.21
9	(Terrain Mult-0.8)*(Humvee Speed (m/s)-19)	Entered	0.0537	3.608228	0.9925	12.624	12	1217.33	1271.7
10	Temperature	Entered	0.0626	2.126361	0.9926	11.153	13	1215.89	1274.38
11	(Move Usage Rate-0.1)*(Humvee Speed (m/s)-19)	Entered	0.0666	2.052506	0.9926	9.8024	14	1214.55	1277.15
12	(Temperature-70)*(Humvee Speed (m/s)-19)	Entered	0.0751	1.923559	0.9926	8.6625	15	1213.41	1280.13
13	(Attack usage Rate-0.4)*(Humvee Speed (m/s)-19)	Entered	0.0808	1.843314	0.9927	7.6536	16	1212.4	1283.21
14	(Temperature-70)*(Attack usage Rate-0.4)	Entered	0.1164	1.485161	0.9927	7.2293	17	1212	1286.9
15	(Terrain Mult-0.8)*(Intel Usage Rate-0.205)	Entered	0.1784	1.088687	0.9928	7.4522	18	1212.28	1291.26
16	(Temperature-70)*(Move Usage Rate-0.1)	Entered	0.1954	1.006533	0.9928	7.8092	19	1212.7	1295.76
17	(Temperature-70)*(Terrain Mult-0.8)	Entered	0.2141	0.925349	0.9928	8.2987	20	1213.27	1300.39
18	Best	Specific	.	.	0.9923	17.966	8	1222.43	1260.21

Figure 23. JMP Stepwise Regression Analysis of the Total AN/PRC-153 Amp-Hours

The results of this stepwise regression presented 17 candidate regression models. Based on the BIC criteria, step 18 is identified as the preferred model (seven total factors, highlighted in blue). Based on the results of the stepwise regression, least squares regression was conducted and evaluated using an actual by predicted plot. The graphical assessment of how well the raw data fits the prediction expression is shown in Figure 24.

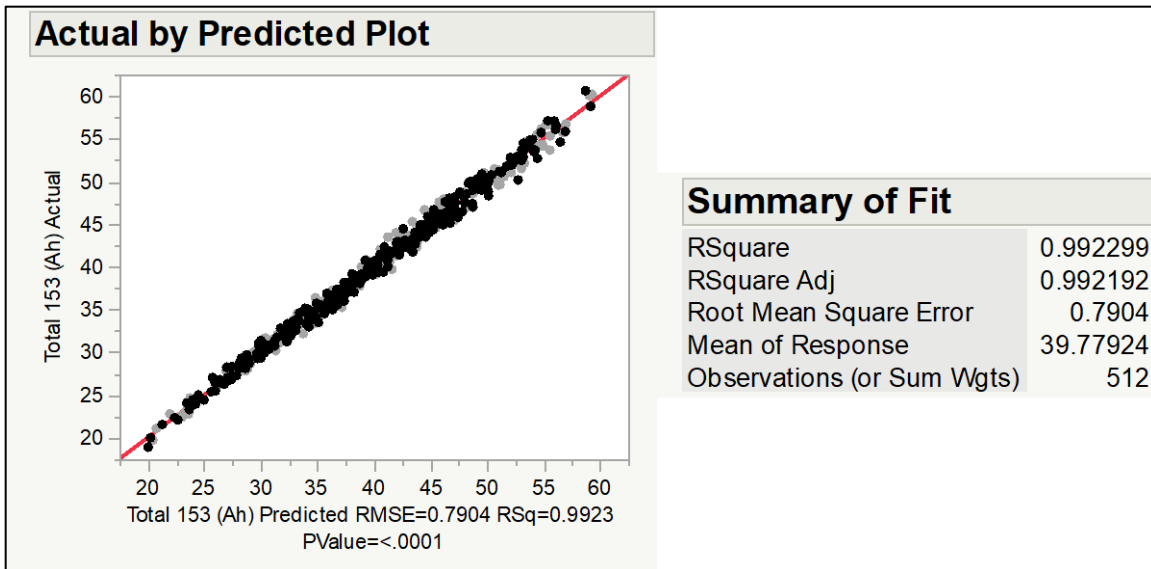

Figure 24. Total AN/PRC-153 Amp-Hours Actual by Prediction Plot and Summary of Fit

The prediction plot shows that the regression model is an excellent fit to the data and has a slightly higher RSquare value than the prediction model for the total batteries required. The summary of fit shows the riflemen consumed a collective mean of 39.78 Ah or approximately 4.42 Ah per riflemen. The variables and their impact on the model are shown in the effect summary (Figure 25).

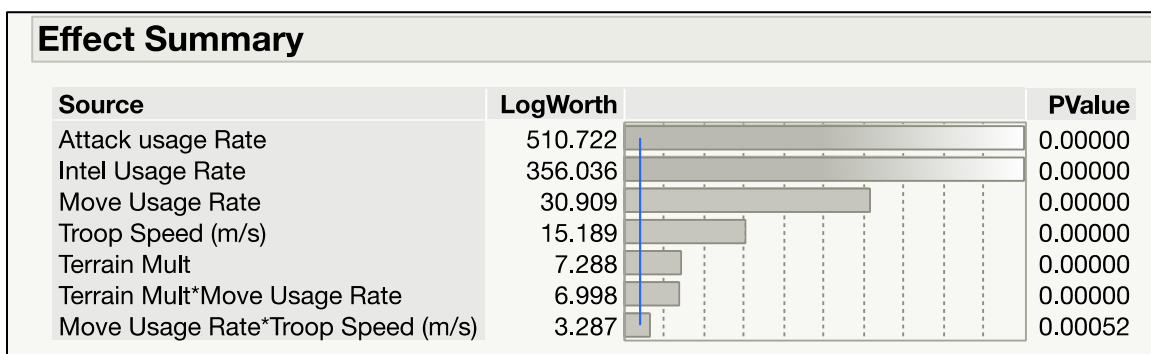

Figure 25. Total AN/PRC-153 Amp-Hours Effects Summary Shows Factor Significance

Here we see that the usage rates, for each phase, have the most impact on this model. Unlike the effect summary for the total AN/PRC-153 batteries (Figure 19), this model does not include the battery capacity or temperature in its prediction model. This is most likely the result of ExtendSim collecting the total Amp-hours consumed before calculating the required number of batteries based on the battery capacity and selected temperature. Even though this model has a slightly higher RSquare value, the variables that are responsible for the majority of the variation are not controllable by a decision maker. There can be many unexpected factors that can cause the usage rates to increase or affect how fast troops move. While not within the scope of this study, there would be interest in examining how substantially the results change when the planned operation is executed with minimal communication, i.e. radio silence during operations.

4. Top Five Significant Factors

It is worth exploring the other equipment used in this model to see what factors had the most impact on the batteries required. Additional regression analysis was conducted for all the radio used and is shown in Appendix B. Table 5 lists the top five variables used in their respective prediction models, shown in order of significance.

Table 5. Prediction Model Top Significant Factors

	Total AN/PRC 153 Batteries	Total AN/PRC 152 Batteries	Total AN/PRC 117 Batteries	Total AN/PRC 148 Batteries	Total AN/PRC 150 Batteries
1	Attack Usage Rate	Attack Usage Rate	Attack Usage Rate	Attack Usage Rate	Battery Capacity %
2	Battery Capacity %	Battery Capacity %	Battery Capacity %	Battery Capacity %	Attack Usage Rate
3	Intel Usage Rate	Intel Usage Rate	Intel Usage Rate	Intel Usage Rate	Temperature
4	Temperature	Temperature	Battery Cap% * Attack usage rate	Battery Cap% * Attack usage rate	Intel Usage Rate
5	Battery Cap% * Attack usage rate	Battery Cap% * Attack usage rate	Troop Speed (m/s)	Battery Cap% * Intel usage rate	Troop Speed (m/s)

There was an expectation that the radio usage during the attack/intel phase and the radio's battery capacity would be significant factors in all prediction models. Table 5 summarizes the previous analyses and confirms our expectations. In addition, those three factors had the same order of precedence in all the models except for the AN/PRC-150. Both the AN/PRC-153 and AN/PRC-152 had the same top five factors and both prediction models have extremely significant correlation to the data.

The regression analysis for the AN/PSN – 13(B) DAGR is also shown in Appendix B. Its factors were not included in Table 5 because the prediction model only had a RSquare value of 0.12. This is because the DAGR does not vary its usage by phase and is assumed to be on for the entire duration of the model. The DAGR's battery capacity, temperature, troop speed and the battery capacities interactions between troop speed and temperature were the only factors used in the regression model. After 512 design simulations the only had a mean of one battery required for the mission.

V. CONCLUSIONS AND RECOMMENDATIONS

A. SUMMARY

The objective of this thesis was to inform USMC operational energy policy through an analysis of battery usage in infantry operations. In support of that broader objective, this thesis conducted analysis of the USMC Expeditionary Energy Office's IPOWER tool, a deterministic program a deterministic program which only focused on squad level operations, by developing a scalable simulation. To achieve this objective it was important incorporate operational/environmental variability and use a statistical method to make recommendations that increases the decision-maker's understanding on what variables have the largest impact on battery usage.

Chapter II introduced the program IPOWER to gain an understanding of how it uses the operator's inputs of mission equipment and mission profiles to produce outputs of the energy consumption analysis. The discussion continues with a review of how IPOWER categorizes/defines different types equipment and reviews recent studies to learn what factors affect and to what magnitude of affect they have on the performance of lithium-ion batteries. This section concludes with a review of current Marine Corps infantry battalion structure and relevant offensive operational doctrine to help form a model.

Chapter III used the IPOWER mission profile, operating conditions and equipment defined by Alisa et al. (2019) to create a model architecture. This architecture captured the operational activities and systems associated with energy consumption of USMC radio equipment for a small unit operation. Chapter IV then used the developed architecture to create a discrete event simulation in ExtendSim. A nearly orthogonal and balanced design of experiments was created, which allowed for an analysis of the simulation, using JPM's statistical software, to identify key performance variables and a comparison to the analysis of Alisa et al. It was concluded that the radios' transmit usage rates and initial battery capacity have the most statistically significant impact to the number of batteries required to complete the mission. It was shown that the initial battery capacity and temperature were useful controllable or known factors that can allow the operator to gain additional insight

in the model's behavior. The data distributions produced from the NOB experimental design showed the most likely number of batteries required to complete the mission. It was concluded that the analysis conducted by Alisa et al. fell within the higher quantiles of these distributions and may overestimate the number of batteries required to complete the mission.

B. CONCLUSION

The goal of this thesis was to further increase the decision-maker's ability to support Marines in tactical environments, by using statistical methods to further analyze E2O's IPOWER tool. This goal was accomplished by defining an IPOWER mission profile, developing an overall systems architecture capturing operational activities, and by creating a discrete simulation in ExtendSim of the defined IPOWER mission and its outputs. Accomplishing those three objects allowed for the analysis of the simulation to identify key performance factors and compare its results with IPOWER's outputs. The analysis concluded that the initial battery capacity, attack and intel radio usage rates were the most significant variables for the warfighter to consider in his or her mission planning. The analysis also showed a mean of fewer required batteries to complete the mission than what was found by Alisa et al. (2019). Additionally, this work accomplished a higher-level goal which will help improve the Marine Corps management of the War Reserve Materiel Program, aid in the logistics of mission planning requiring high demands of energy and aid in the analysis (war gaming) of plausible future vignettes to develop future military strategies.

This thesis shows that IPOWER is capable of calculating energy usage and additionally this work highlights the potential limitations of IPOWER. All models are only as reliable as the assumptions that constrain their output. Opportunities for error occur without accurate equipment databases and for operators with limited to no operational experience. Due to a lack of available information from product descriptions, some assumptions were needed to define radio set performance parameters. Additionally, IPOWER gives significant control to the user by allowing the operator to define mission parameters, equipment usage rates, durations and equipment parameters. This thesis,

through experimental design, shows there is significant variability when trying to define mission parameters in a program like IPOWER. It is impossible to predict exact mission durations, exactly how fast forces will travel, exact environmental conditions, initial battery capacities and their usage rates. This amount of variability can significantly influence IPOWER's output and may give an unrealistic answer. The model developed by this this thesis incorporates variability into the user's decision, allowing the operator to see a distribution of possible outputs. This allows the operator to assume a level of risk, how much of the distribution to include, in determining the appropriate number of batteries required.

C. FUTURE WORK

One of the initial goals of this thesis was to determine how different methods of battery charging affected the total number of batteries required to complete the mission. Like many of the different types of batteries found on the commercial market the lithium-ion battery packs used by the USMC also have the capability of recharging. The USMC is capable of Humvee and pack mounted recharging units to possibly decrease the number of batteries needed for missions, but there is little readily available information on the charging rates achieved from their equipment. The vignette defined by Alisa et al. (2019) also did not support adding this capability at any phase to the model. To have a relevant 1 to 1 comparison, this capability was excluded but can be easily implemented into an ExtendSim model. It is my belief the capability would benefit a campaign, where there are a series of missions without returning to base to resupply. It would be worth studying how much of an impact this capability has on the number of batteries required to complete different types of missions or a campaign.

THIS PAGE INTENTIONALLY LEFT BLANK

APPENDIX A. EXTENDSIM MODEL

This appendix shows detailed, zoomed in pictures, descriptions of each phase.

A. PLAN PHASE

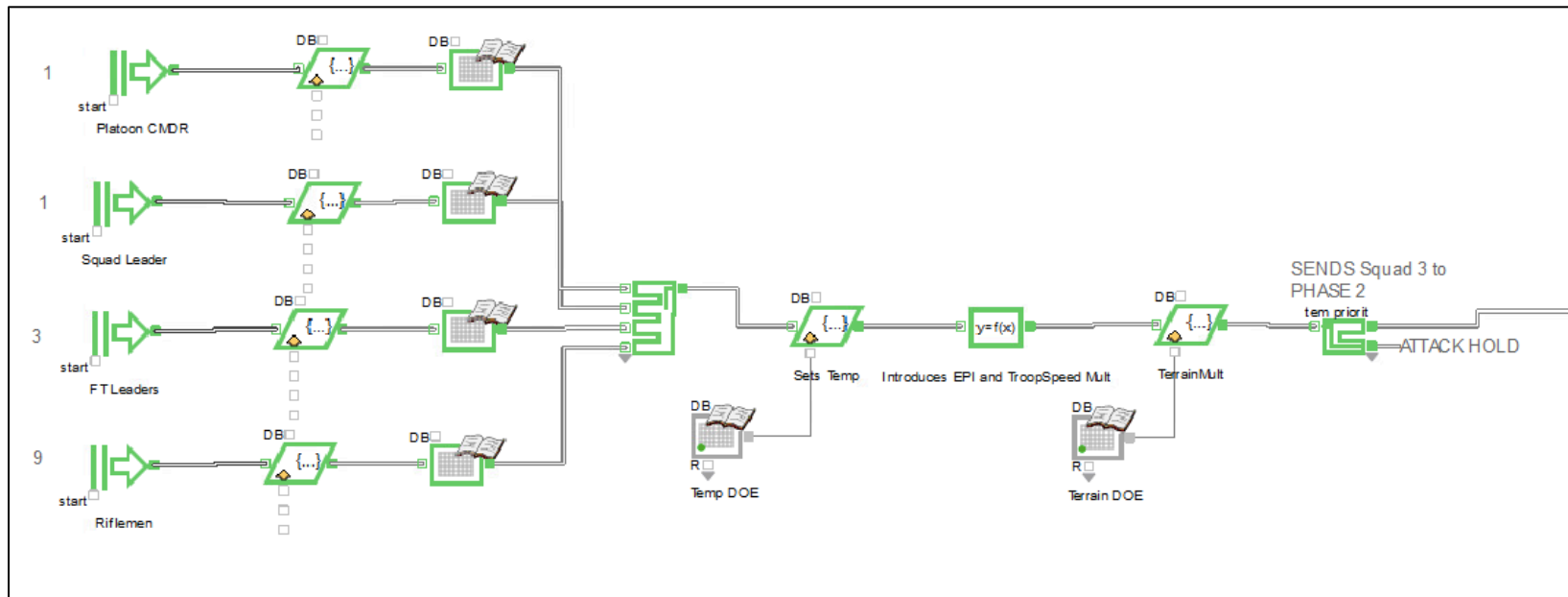

Figure 26. ExtendSim 10 Model (Plan Phase)

B. OBSERVE PHASE

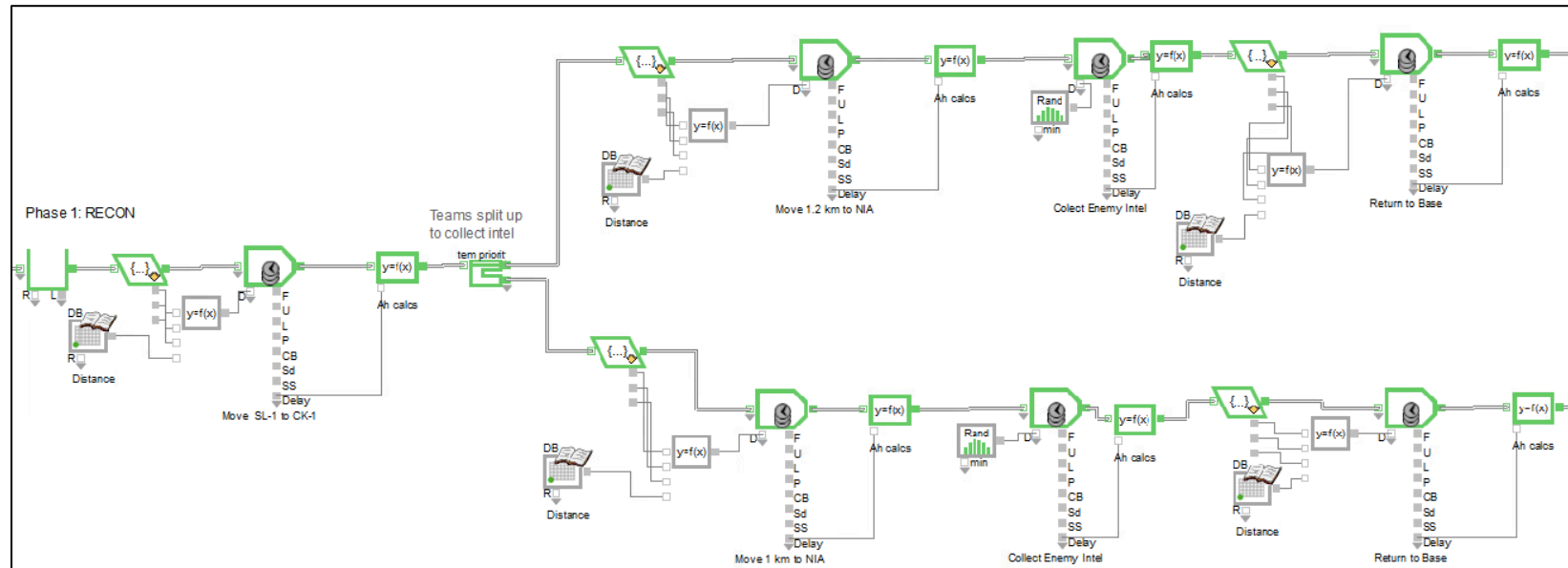

Figure 27. ExtendSim 10 Model (Observe Phase)

D. SECURE PHASE

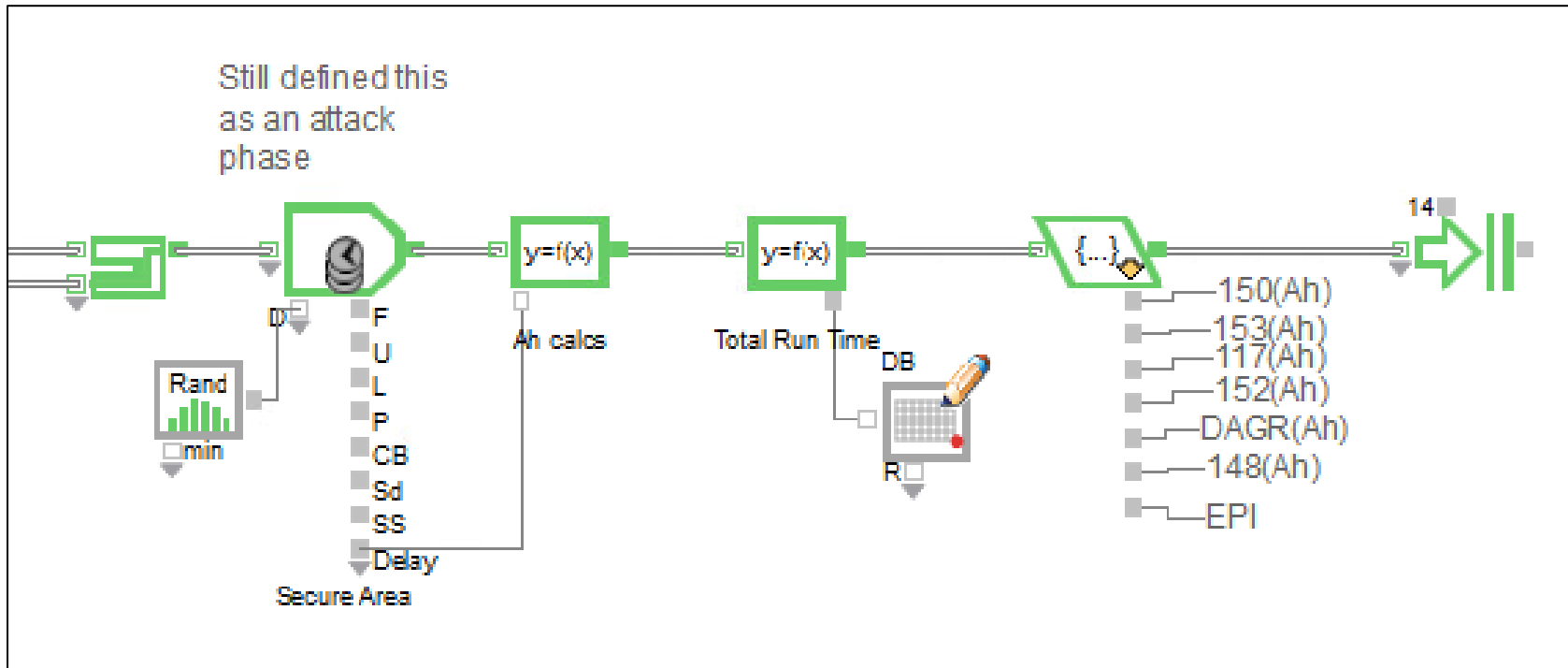

Figure 29. ExtendSim 10 Model (Secure Phase)

E. ENERGY CONSUMPTION CALCULATIONS

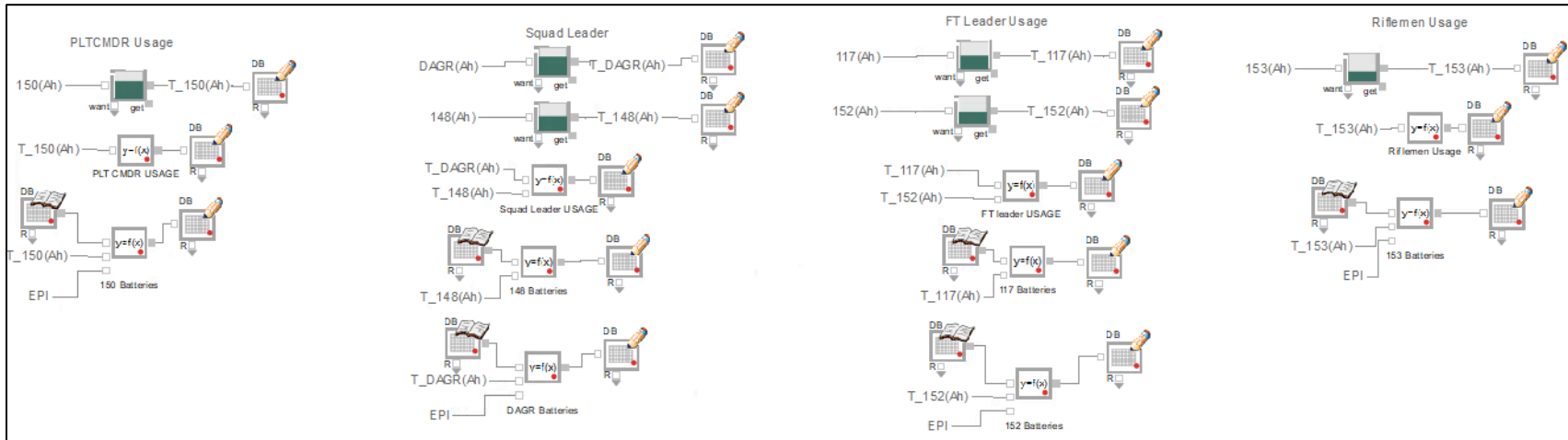

Figure 30. ExtendSim 10 Model (Energy Consumption Calculations)

THIS PAGE INTENTIONALLY LEFT BLANK

APPENDIX B. ADDITIONAL REGRESSION ANALYSIS

A. TOTAL AN/PRC—150 BATTERIES

1. Stepwise Regression

Step History									
Step	Parameter	Action	"Sig Prob"	Seq SS	RSquare	Cp	p	AICc	BIC
1	Battery Capacity %	Entered	0.0000	22.90863	0.5874	1058.8	2	-312.53	-299.86
2	Attack usage Rate	Entered	0.0000	4.389871	0.7000	633.37	3	-473.61	-456.74
3	Temperature	Entered	0.0000	2.681331	0.7687	374.27	4	-604.84	-583.76
4	Intel Usage Rate	Entered	0.0000	2.233238	0.8260	158.81	5	-748.45	-723.19
5	Troop Speed (m/s)	Entered	0.0000	1.054945	0.8530	58.08	6	-832.9	-803.46
6	Terrain Mult	Entered	0.0000	0.4718	0.8651	14.137	7	-874.82	-841.2
7	(Battery Capacity %-0.85)*(Intel Usage Rate-0.205)	Entered	0.0229	0.053821	0.8665	10.896	8	-878.02	-840.23
8	Move Usage Rate	Entered	0.0339	0.046384	0.8677	8.3792	9	-880.52	-838.58
9	(Battery Capacity %-0.85)*(Attack usage Rate-0.4)	Entered	0.0433	0.041832	0.8688	6.3057	10	-882.6	-836.51
10	(Temperature-70)*(Battery Capacity %-0.85)	Entered	0.0928	0.028812	0.8695	5.5001	11	-883.39	-833.16
11	(Attack usage Rate-0.4)*(Intel Usage Rate-0.205)	Entered	0.0948	0.028351	0.8703	4.7393	12	-884.15	-829.78
12	(Terrain Mult-0.8)*(Intel Usage Rate-0.205)	Entered	0.1755	0.018593	0.8707	4.9287	13	-883.92	-825.43
13	(Attack usage Rate-0.4)*(Humvee Speed (m/s)-19)	Entered	0.2131	0.031265	0.8715	5.8842	15	-882.85	-816.14
14	(Terrain Mult-0.8)*(Troop Speed (m/s)-1.785)	Entered	0.2067	0.016096	0.8719	6.3169	16	-882.36	-811.54
15	(Move Usage Rate-0.1)*(Troop Speed (m/s)-1.785)	Entered	0.2245	0.014877	0.8723	6.8682	17	-881.74	-806.83
16	(Terrain Mult-0.8)*(Battery Capacity %-0.85)	Entered	0.2397	0.013931	0.8727	7.5117	18	-881.01	-802.03
17	Best	Specific	.	.	0.8651	14.137	7	-874.82	-841.2

Figure 31. JMP Stepwise Regression Analysis of the Total AN/PRC-150 Batteries

2. Prediction Plot and Summary of Fit

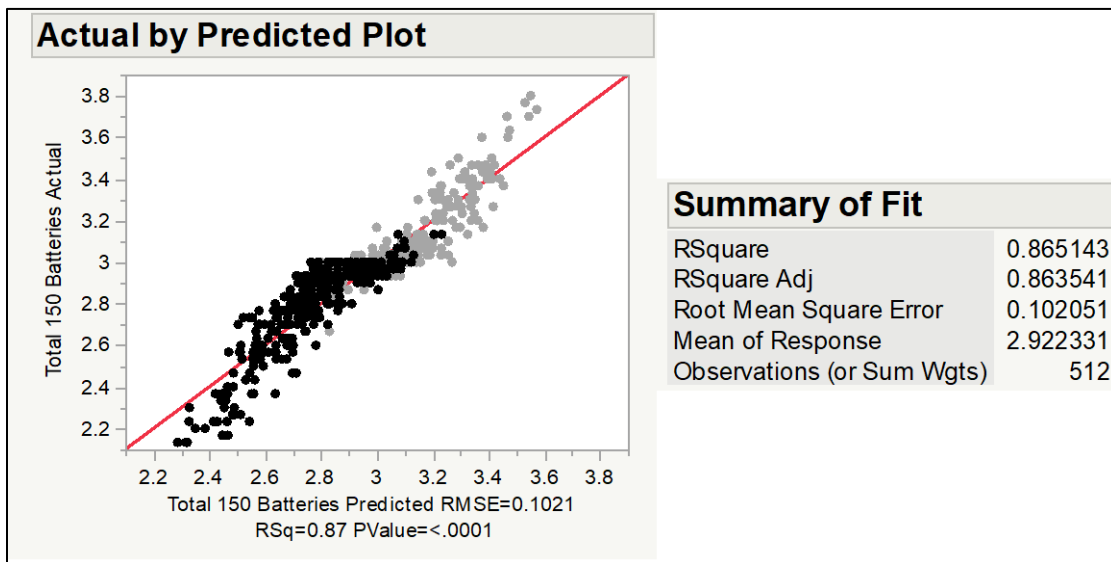

Figure 32. Total AN/PRC-150 Batteries Actual by Prediction Plot and Summary of Fit

3. Model Variables

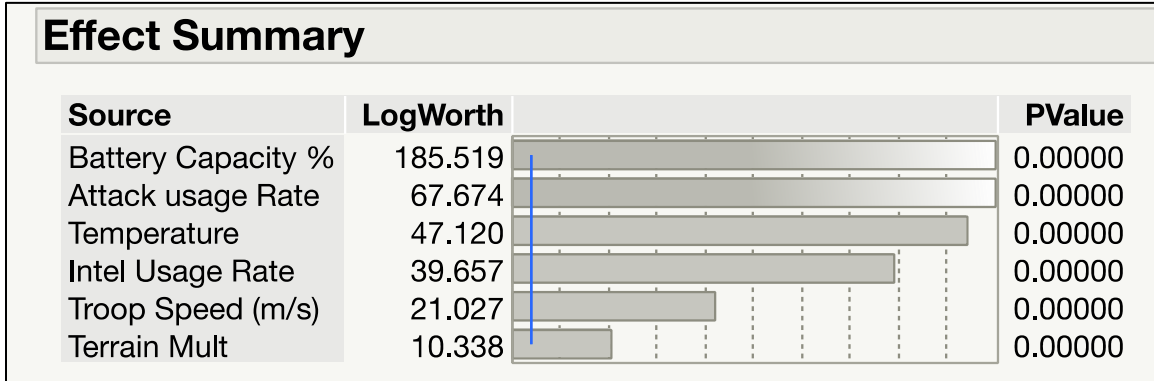

Figure 33. Total AN/PRC-150 Batteries Effects Summary Shows Factor Significance

B. TOTAL AN/PRC—117 BATTERIES

1. Stepwise Regression

Step History									
Step	Parameter	Action	"Sig Prob"	Seq SS	RSquare	Cp	p	AICc	BIC
1	Attack usage Rate	Entered	0.0000	101.8022	0.5015	9264.7	2	628.989	641.657
2	Battery Capacity %	Entered	0.0000	68.06139	0.8367	2694.4	3	59.4571	76.3315
3	Intel Usage Rate	Entered	0.0000	25.13533	0.9606	269.15	4	-665.82	-644.75
4	(Battery Capacity % -0.85)*(Attack usage Rate-0.4)	Entered	0.0000	0.958665	0.9653	178.57	5	-729.07	-703.81
5	Troop Speed (m/s)	Entered	0.0000	0.899581	0.9697	93.706	6	-796.93	-767.48
6	Terrain Mult	Entered	0.0000	0.314804	0.9713	65.307	7	-821.78	-788.16
7	Move Usage Rate	Entered	0.0000	0.276045	0.9726	40.651	8	-844.53	-806.74
8	(Terrain Mult-0.8)*(Move Usage Rate-0.1)	Entered	0.0007	0.125938	0.9732	30.489	9	-854.18	-812.24
9	(Battery Capacity % -0.85)*(Intel Usage Rate-0.205)	Entered	0.0014	0.109695	0.9738	21.897	10	-862.54	-816.44
10	Temperature	Entered	0.0069	0.076931	0.9742	16.468	11	-867.9	-817.66
11	(Temperature-70)*(Attack usage Rate-0.4)	Entered	0.0136	0.06353	0.9745	12.333	12	-872.03	-817.66
12	(Intel Usage Rate-0.205)*(Troop Speed (m/s)-1.785)	Entered	0.0221	0.054119	0.9747	9.107	13	-875.29	-816.8
13	(Terrain Mult-0.8)*(Troop Speed (m/s)-1.785)	Entered	0.0565	0.037336	0.9749	7.5017	14	-876.91	-814.3
14	(Move Usage Rate-0.1)*(Troop Speed (m/s)-1.785)	Entered	0.0615	0.035708	0.9751	6.0536	15	-878.39	-811.67
15	(Temperature-70)*(Battery Capacity % -0.85)	Entered	0.0900	0.029232	0.9752	5.2308	16	-879.22	-808.4
16	(Move Usage Rate-0.1)*(Humvee Speed (m/s)-19)	Entered	0.2672	0.026776	0.9754	6.6452	18	-877.64	-798.66
17	(Terrain Mult-0.8)*(Humvee Speed (m/s)-19)	Entered	0.2018	0.016506	0.9755	7.0513	19	-877.17	-794.12
18	(Battery Capacity % -0.85)*(Move Usage Rate-0.1)	Entered	0.3302	0.009599	0.9755	8.1243	20	-875.99	-788.87
19	(Battery Capacity % -0.85)*(Troop Speed (m/s)-1.785)	Entered	0.3677	0.008219	0.9755	9.3307	21	-874.65	-783.47
20	(Terrain Mult-0.8)*(Intel Usage Rate-0.205)	Entered	0.4298	0.006317	0.9756	10.721	22	-873.11	-777.89
21	(Attack usage Rate-0.4)*(Humvee Speed (m/s)-19)	Entered	0.4188	0.00663	0.9756	12.08	23	-871.59	-772.34
22	Best	Specific	.	.	0.9745	12.333	12	-872.03	-817.66

Figure 34. JMP Stepwise Regression Analysis of The Total AN/PRC-117 Batteries.

2. Prediction Plot and Summary of Fit

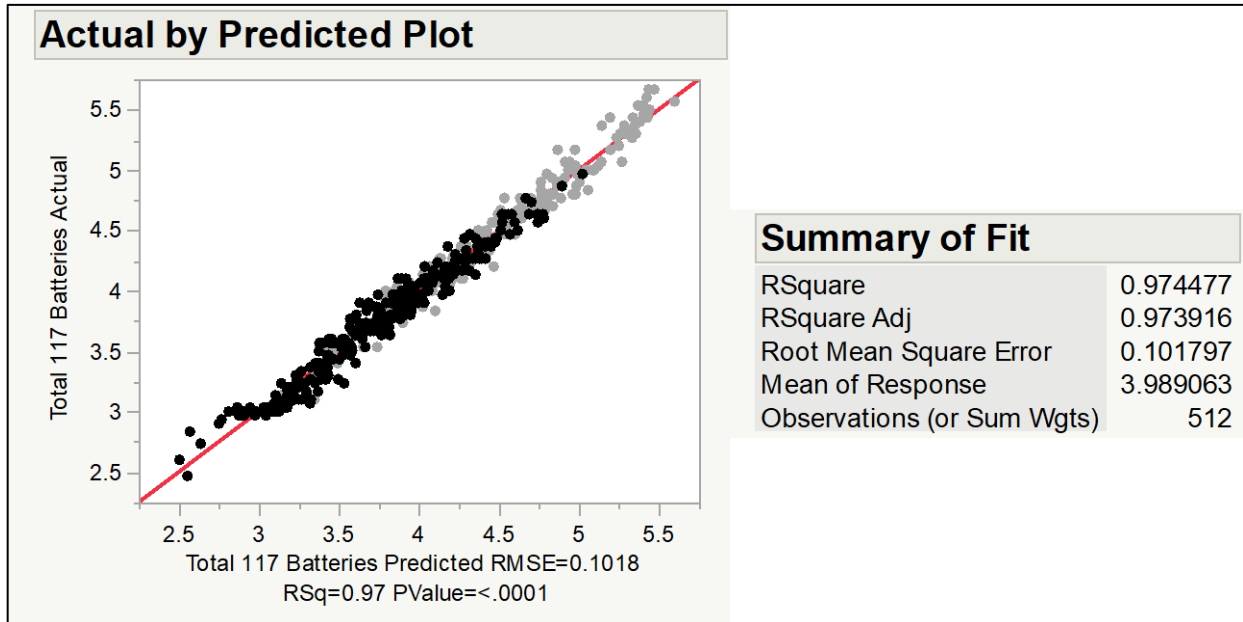

Figure 35. Total AN/PRC-117 Batteries Actual by Prediction Plot and Summary of Fit

3. Model Variables

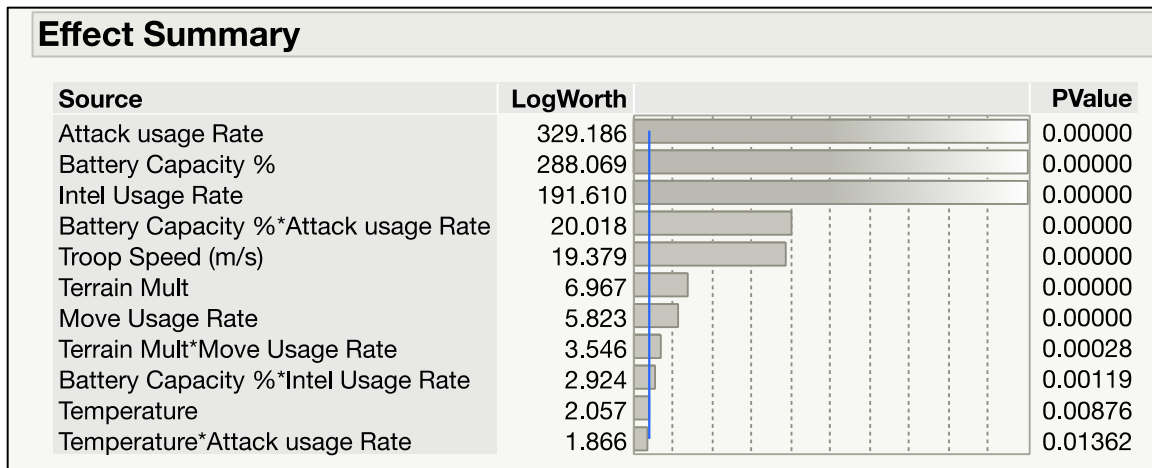

Figure 36. Total AN/PRC-117 Batteries Effects Summary Shows Factor Significance

C. TOTAL AN/PRC—152 BATTERIES

1. Stepwise Regression

Step History									
Step	Parameter	Action	"Sig Prob"	Seq SS	RSquare	Cp	p	AICc	BIC
1	Attack usage Rate	Entered	0.0000	353.0714	0.5604	9468.1	2	1144.34	1157.01
2	Battery Capacity %	Entered	0.0000	155.2537	0.8069	3876.8	3	725.255	742.129
3	Intel Usage Rate	Entered	0.0000	82.68135	0.9381	900.06	4	144.475	165.549
4	Temperature	Entered	0.0000	16.37495	0.9641	312.13	5	-132.52	-107.26
5	(Battery Capacity %-0.85)*(Attack usage Rate-0.4)	Entered	0.0000	3.800569	0.9702	177.2	6	-224.75	-195.3
6	Troop Speed (m/s)	Entered	0.0000	1.541879	0.9726	123.65	7	-266.5	-232.88
7	Move Usage Rate	Entered	0.0000	1.087626	0.9743	86.471	8	-297.76	-259.98
8	(Temperature-70)*(Attack usage Rate-0.4)	Entered	0.0000	0.683684	0.9754	63.84	9	-317.81	-275.86
9	Terrain Mult	Entered	0.0000	0.617485	0.9764	43.595	10	-336.55	-290.46
10	(Battery Capacity %-0.85)*(Intel Usage Rate-0.205)	Entered	0.0000	0.527652	0.9772	26.585	11	-352.96	-302.72
11	(Terrain Mult-0.8)*(Humvee Speed (m/s)-19)	Entered	0.0066	0.286016	0.9777	20.281	13	-359.06	-300.56
12	(Move Usage Rate-0.1)*(Troop Speed (m/s)-1.785)	Entered	0.0228	0.145766	0.9779	17.029	14	-362.27	-299.66
13	(Temperature-70)*(Intel Usage Rate-0.205)	Entered	0.0316	0.128819	0.9781	14.388	15	-364.9	-298.19
14	(Battery Capacity %-0.85)*(Move Usage Rate-0.1)	Entered	0.0609	0.09734	0.9783	12.881	16	-366.39	-295.58
15	(Attack usage Rate-0.4)*(Humvee Speed (m/s)-19)	Entered	0.0821	0.083382	0.9784	11.878	17	-367.38	-292.47
16	(Battery Capacity %-0.85)*(Humvee Speed (m/s)-19)	Entered	0.1182	0.067106	0.9785	11.46	18	-367.75	-288.77
17	(Attack usage Rate-0.4)*(Intel Usage Rate-0.205)	Entered	0.1270	0.063822	0.9786	11.161	19	-368.01	-284.95
18	(Battery Capacity %-0.85)*(Troop Speed (m/s)-1.785)	Entered	0.1802	0.049121	0.9787	11.391	20	-367.7	-280.58
19	(Temperature-70)*(Humvee Speed (m/s)-19)	Entered	0.2906	0.030516	0.9788	12.292	21	-366.68	-275.51
20	(Move Usage Rate-0.1)*(Humvee Speed (m/s)-19)	Entered	0.2656	0.033845	0.9788	13.072	22	-365.79	-270.57
21	Best	Specific	.	.	0.9772	26.585	11	-352.96	-302.72

Figure 37. JMP Stepwise Regression Analysis of the Total AN/PRC-152 Batteries

2. Prediction Plot and Summary of Fit

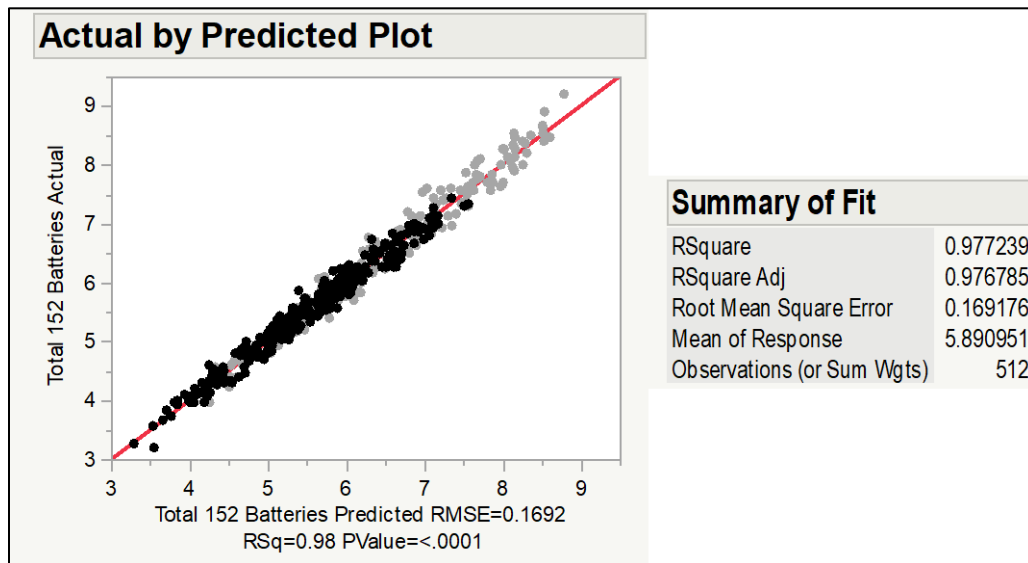

Figure 38. Total AN/PRC-152 Batteries Actual by Prediction Plot and Summary of Fit

3. Model Variables

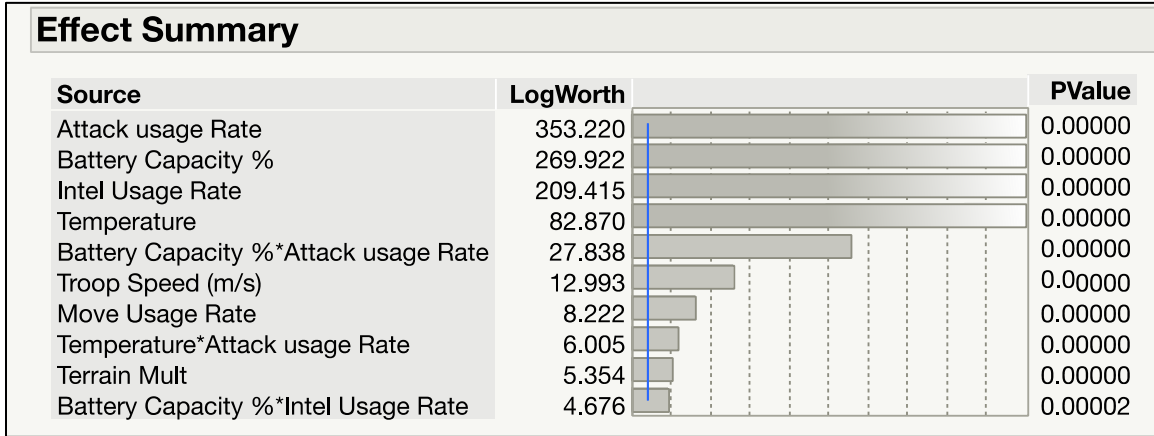

Figure 39. Total AN/PRC-152 Batteries Effects Summary Shows Factor Significance

D. TOTAL AN/PRC—148 BATTERIES

1. Stepwise Regression

Step History									
Step	Parameter	Action	"Sig Prob"	Seq SS	RSquare	Cp	p	AICc	BIC
1	Attack usage Rate	Entered	0.0000	40.93483	0.4446	3165.8	2	279.442	292.11
2	Battery Capacity %	Entered	0.0000	22.5479	0.6895	1547.8	3	-16.28	0.59421
3	Intel Usage Rate	Entered	0.0000	19.86789	0.9053	122.29	4	-622.3	-601.23
4	(Battery Capacity %-0.85)*(Attack usage Rate-0.4)	Entered	0.0000	0.544255	0.9112	85.186	5	-653.26	-628
5	(Battery Capacity %-0.85)*(Intel Usage Rate-0.205)	Entered	0.0000	0.310601	0.9146	64.87	6	-671.05	-641.6
6	Troop Speed (m/s)	Entered	0.0000	0.281466	0.9177	46.647	7	-687.65	-654.03
7	(Attack usage Rate-0.4)*(Intel Usage Rate-0.205)	Entered	0.0002	0.206104	0.9199	33.839	8	-699.69	-661.9
8	Move Usage Rate	Entered	0.0036	0.123541	0.9212	26.963	9	-706.26	-664.31
9	Terrain Mult	Entered	0.0062	0.10734	0.9224	21.25	10	-711.81	-665.71
10	(Terrain Mult-0.8)*(Move Usage Rate-0.1)	Entered	0.0110	0.091603	0.9234	16.669	11	-716.32	-666.08
11	(Move Usage Rate-0.1)*(Humvee Speed (m/s)-19)	Entered	0.0248	0.103703	0.9245	13.218	13	-719.68	-661.19
12	(Move Usage Rate-0.1)*(Troop Speed (m/s)-1.785)	Entered	0.0809	0.042411	0.9250	12.171	14	-720.69	-658.09
13	(Terrain Mult-0.8)*(Battery Capacity %-0.85)	Entered	0.0756	0.043772	0.9255	11.026	15	-721.82	-655.1
14	(Terrain Mult-0.8)*(Humvee Speed (m/s)-19)	Entered	0.0966	0.038132	0.9259	10.286	16	-722.53	-651.72
15	(Attack usage Rate-0.4)*(Troop Speed (m/s)-1.785)	Entered	0.1592	0.027288	0.9262	10.325	17	-722.43	-647.53
16	(Terrain Mult-0.8)*(Attack usage Rate-0.4)	Entered	0.1600	0.02714	0.9265	10.375	18	-722.33	-643.34
17	(Battery Capacity %-0.85)*(Move Usage Rate-0.1)	Entered	0.2015	0.022392	0.9267	10.767	19	-721.86	-638.8
18	(Attack usage Rate-0.4)*(Move Usage Rate-0.1)	Entered	0.2701	0.016676	0.9269	11.569	20	-720.95	-633.83
19	(Attack usage Rate-0.4)*(Humvee Speed (m/s)-19)	Entered	0.3218	0.013453	0.9270	12.602	21	-719.79	-628.62
20	(Intel Usage Rate-0.205)*(Troop Speed (m/s)-1.785)	Entered	0.3305	0.012981	0.9272	13.669	22	-718.59	-623.37
21	Best	Specific	.	.	0.9234	16.669	11	-716.32	-666.08

Figure 40. JMP Stepwise Regression Analysis of the Total AN/PRC-148 Batteries

2. Prediction Plot and Summary of Fit

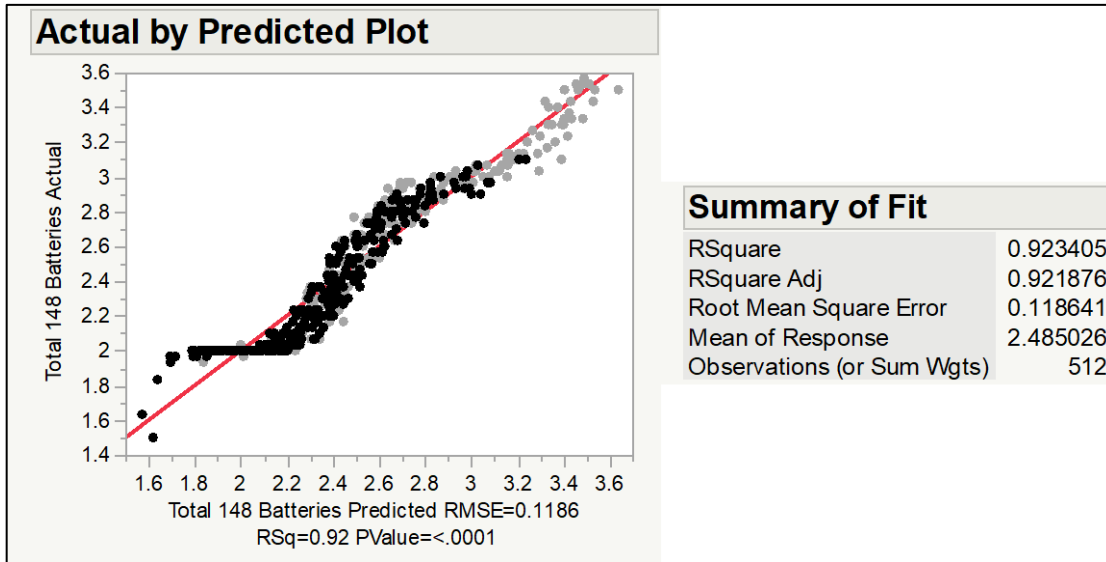

Figure 41. Total AN/PRC-148 Batteries Actual by Prediction Plot and Summary of Fit

3. Model Variables

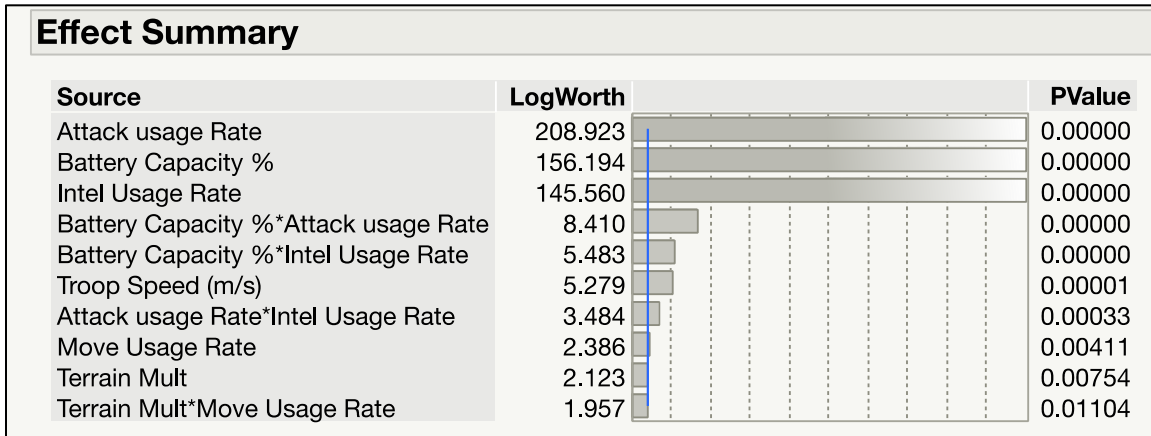

Figure 42. Total AN/PRC-148 Batteries Effects Summary Shows Factor Significance

E. TOTAL AN/PSN—13(B) DAGR BATTERIES

1. Stepwise Regression

Step History									
Step	Parameter	Action	"Sig Prob"	Seq SS	RSquare	Cp	p	AICc	BIC
1	(Battery Capacity %-0.85)*(Troop Speed (m/s)-1.785)	Entered	0.0000	0.000731	0.0953	18.068	4	-4275.7	-4254.7
2	(Temperature-70)*(Battery Capacity %-0.85)	Entered	0.0015	0.000192	0.1203	7.6209	6	-4286	-4256.6
3	(Temperature-70)*(Troop Speed (m/s)-1.785)	Entered	0.0421	0.000055	0.1275	5.4801	7	-4288.1	-4254.5
4	Terrain Mult	Entered	0.1138	3.315e-5	0.1318	4.9864	8	-4288.6	-4250.8
5	(Terrain Mult-0.8)*(Battery Capacity %-0.85)	Entered	0.1564	2.658e-5	0.1353	4.9873	9	-4288.6	-4246.6
6	(Temperature-70)*(Humvee Speed (m/s)-19)	Entered	0.1380	5.224e-5	0.1421	5.0579	11	-4288.4	-4238.2
7	(Attack usage Rate-0.4)*(Humvee Speed (m/s)-19)	Entered	0.1233	0.000055	0.1492	4.9213	13	-4288.5	-4230
8	(Battery Capacity %-0.85)*(Attack usage Rate-0.4)	Entered	0.1493	2.723e-5	0.1528	4.8734	14	-4288.5	-4225.9
9	(Temperature-70)*(Terrain Mult-0.8)	Entered	0.1418	2.819e-5	0.1565	4.7526	15	-4288.6	-4221.9
10	(Temperature-70)*(Attack usage Rate-0.4)	Entered	0.3163	1.31e-5	0.1582	5.767	16	-4287.5	-4216.7
11	(Move Usage Rate-0.1)*(Troop Speed (m/s)-1.785)	Entered	0.3615	2.655e-5	0.1616	7.7698	18	-4285.3	-4206.3
12	(Terrain Mult-0.8)*(Move Usage Rate-0.1)	Entered	0.2414	1.79e-5	0.1640	8.4235	19	-4284.6	-4201.5
13	Best	Specific	.	.	0.1203	7.6209	6	-4286	-4256.6

Figure 43. JMP Stepwise Regression Analysis of the Total AN/PSN – 13(B) DAGR Batteries

2. Prediction Plot and Summary of Fit

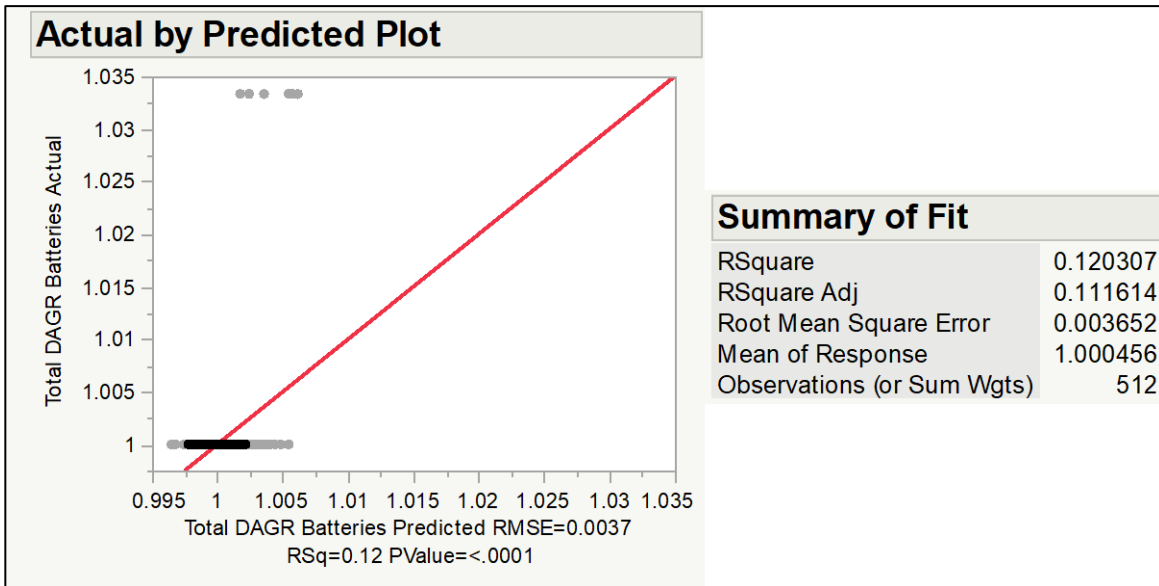

Figure 44. Total AN/PSN – 13(B) DAGR Batteries Actual by Prediction Plot and Summary of Fit

3. Model Variables

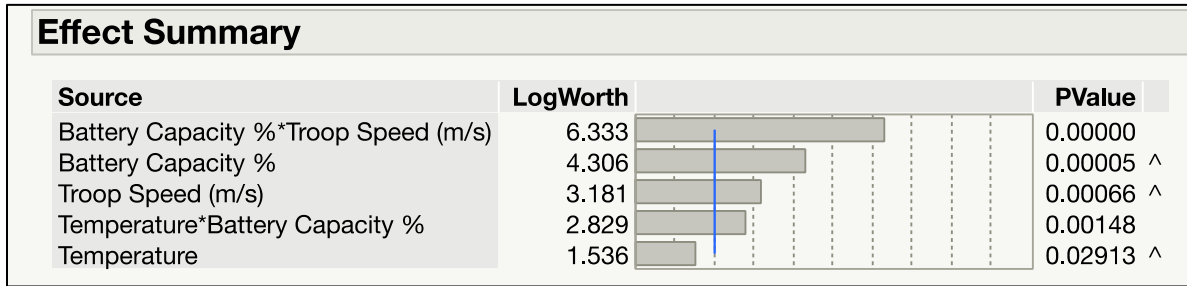

Figure 45. Total AN/PSN – 13(B) DAGR Batteries Effects Summary Shows Factor Significance

LIST OF REFERENCES

- Alisa, Rasida, Mark A. Kotwicki II, and Peter J. Marbach. 2019. "Assessing the Impact of Tactical Mission Profiles on The Development of Power Prediction Software." Systems Engineering Capstone Report, Naval Postgraduate School.
- Analytical Systems Engineering Corporation. 1996. *Battery Support to the Fleet Marine Force Study: Final Report*. Contract No. M00027-95-D-0008/D.O. 0001. Dumfries, VA: Analytical Systems Engineering Corporation
- Beery, Paul, and Eugene Paulo. 2019. "Application of Model-Based Systems Engineering Concepts to Support Mission Engineering." *Systems* 7, no. 3, 44. <https://doi.org/10.3390/systems7030044>.
- Gold, Robert. 2016. "Mission Engineering." Paper presented at the 119th Annual NDIA Systems Engineering Conference, Springfield, VA. https://ndiastorage.blob.core.usgovcloudapi.net/ndia/2016/systems/18950_RobertGold.pdf.
- INCOSE. 2007. *Systems Engineering Vision 2020*. TP-2004-004-02. San Diego, CA: INCOSE.
- Kumar, S. Krishna, Audy A. B. M. Abduh, Othmane Sabih, and Rachid Yazami. 2018. "Temperature Effect on 'Ragone Plots' of Lithium-Ion Batteries." *Journal of The Electrochemical Society* 165, no. 3 (March): A674–A679. <https://doi.org/10.1149/2.0591803jes>.
- MacCalman, Alex, Paul Beery, and Eugene Paulo. (2016). "A Systems Design Exploration Approach that Illuminates Tradespaces Using Statistical Experimental Designs." *Systems Engineering* 19, no. 5(September): 409–421. <https://doi.org/10.1002/sys.21352>.
- Marine Corps Combat Development and Integration. 2018. "Publication of Fiscal Years 2019 through 2039 Tables of Organization and Equipment." <https://www.marines.mil/News/Messages/Messages-Display/Article/1626876/publication-of-fiscal-years-2019-through-2039-tables-of-organization-and-equipm/>.
- Marine Corps Expeditionary Energy Office. 2011. *Marine Corps Expeditionary Energy Strategy and Implementation Plan*. Washington, DC: Expeditionary Energy Office. <https://www.hqmc.marines.mil/Portals/160/Docs/USMC%20Expeditionary%20Energy%20Strategy%20%20Implementation%20Planning%20Guidance.pdf>

- Marine Requirements Oversight Council. 2011. *Initial Capabilities Document for United States Marine Corps Expeditionary Energy, Water, and Waste*. CDTM Document Number: 11110808578-v2. Washington, DC: Marine Requirements Oversight Council. <https://www.hqmc.marines.mil/Portals/160/Docs/USMC%20E2W2%20ICD.pdf>
- Stroman, Richard. 2018a. *IPOWER: Dismounted Soldier Energy Analysis and Mission Planning Tools*. Washington, DC: U.S. Naval Research Laboratory. <http://www.powersourceconference.com/Power%20Sources%202018%20Digest/docs?8-1.pdf>.
- . 2018b. “Overview of IPOWER: An energy simulation tool for dismounted warfighters.” Presentation at Naval Postgraduate School, Monterey, CA, November 8, 2018.
- U.S. Marine Corps. 2015. *Organization of the USMC*. MCRP 1-10.1. Washington, DC: Department the Navy. <https://www.marines.mil/portals/1/Publications/MCRP%201-10.1.pdf?ver=2019-04-02-130622-890>.
- . 2018a. *Military Operations on Urbanized Terrain (MOUT)*. MCRP 12-10B.1 Washington, DC: Department of the Navy. <https://www.marines.mil/Portals/1/Publications/MCRP%2012-10B.1%20GN.pdf?ver=2020-02-12-121429-267>
- . 2018b. *Scouting and Patrolling*. MCTP 3–01A. Washington, DC: Department of the Navy. <https://www.marines.mil/Portals/1/Publications/MCTP%203-01A%20gn.pdf?ver=2019-08-14-081809-713>
- . 2018c. *Warfighting*. MCDP 1. Washington, DC: Department of the Navy. <https://www.marines.mil/portals/1/Publications/MCDP%201%20Warfighting%20GN.pdf?ver=2019-01-31-110543-300>
- . 2019a. *Marine Corps Operations*. MCDP 1-0 W/ CH1-3. Washington, DC: Department of the Navy. <https://www.marines.mil/Portals/1/Publications/MCDP%201-0%20Marine%20Corps%20Operations.pdf>.
- . 2019b. *Marine Rifle Squad*. MCIP 3-10A.4i. Washington, DC: Department of the Navy. <https://www.marines.mil/portals/1/Publications/MCIP%203-10A.4i.pdf?ver=2019-06-20-081543-327>.
- Vieira, H., Susan M. Sanchez, K.H. Kienitz, and M.C.N. Belderrain. 2013. “Efficient, Nearly Orthogonal-and-Balanced, Mixed Designs: An Effective Way to Conduct Trade-Off Analyses via Simulation.” *Journal of Simulation*, vol. 7, 264–275. <http://hdl.handle.net/10945/44877>.

INITIAL DISTRIBUTION LIST

1. Defense Technical Information Center
Ft. Belvoir, Virginia
2. Dudley Knox Library
Naval Postgraduate School
Monterey, California