

# REPORT DOCUMENTATION PAGE

*Form Approved*  
*OMB No. 0704-0188*

The public reporting burden for this collection of information is estimated to average 1 hour per response, including the time for reviewing instructions, searching existing data sources, gathering and maintaining the data needed, and completing and reviewing the collection of information. Send comments regarding this burden estimate or any other aspect of this collection of information, including suggestions for reducing this burden, to Department of Defense, Washington Headquarters Services, Directorate for Information on Operations and Reports (0704-0188), 1215 Jefferson Davis Highway, Suite 1204, Arlington, VA 22202-4302. Respondents should be aware that notwithstanding any other provision of law, no person shall be subject to any penalty for failing to comply with a collection of information if it does not display a currently valid OMB control number.  
**PLEASE DO NOT RETURN YOUR FORM TO THE ABOVE ADDRESS.**

<b>1. REPORT DATE</b> ( <i>DD-MM-YYYY</i> ) 11-03-2021			<b>2. REPORT TYPE</b> Final			<b>3. DATES COVERED</b> ( <i>From - To</i> )		
<b>4. TITLE AND SUBTITLE</b> Test Operations Procedure (TOP) 3-2-040 Boresight Retention					<b>5a. CONTRACT NUMBER</b>			
					<b>5b. GRANT NUMBER</b>			
					<b>5c. PROGRAM ELEMENT NUMBER</b>			
<b>6. AUTHORS</b>					<b>5d. PROJECT NUMBER</b>			
					<b>5e. TASK NUMBER</b>			
					<b>5f. WORK UNIT NUMBER</b>			
<b>7. PERFORMING ORGANIZATION NAME(S) AND ADDRESS(ES)</b> Small Arms Systems Division (CSTE-DTC-AT-FP-S) US Army Aberdeen Test Center 6943 Collieran Road Aberdeen Proving Ground, MD 21005-5059					<b>8. PERFORMING ORGANIZATION REPORT NUMBER</b> TOP 03-2-040			
<b>9. SPONSORING/MONITORING AGENCY NAME(S) AND ADDRESS(ES)</b> Policy and Standardization Division (CSTE-CI-P) U.S. Army Test and Evaluation Command 6617 Aberdeen Boulevard Aberdeen Proving Ground, MD 21005-5001					<b>10. SPONSOR/MONITOR'S ACRONYM(S)</b>			
					<b>11. SPONSOR/MONITOR'S REPORT NUMBER(S)</b> Same as item 8			
<b>12. DISTRIBUTION/AVAILABILITY STATEMENT</b> Approved for public release; distribution unlimited.								
<b>13. SUPPLEMENTARY NOTES</b> Defense Technical Information Center (DTIC), AD No.:								
<b>14. ABSTRACT</b> This TOP contains one procedure for testing boresight retention of hand and shoulder fired weapons and machine guns including crew served weapons and light automatic cannons up to 50 millimeters in caliber. This method uses a parabolic mirror with a laser boresight to track changes over the test period of the weapon system.								
<b>15. SUBJECT TERMS</b> boresight retention, weapon sights, laser bore sight								
<b>16. SECURITY CLASSIFICATION OF:</b>			<b>17. LIMITATION OF ABSTRACT</b>	<b>18. NUMBER OF PAGES</b>	<b>19a. NAME OF RESPONSIBLE PERSON</b>			
<b>a. REPORT</b> Unclassified	<b>b. ABSTRACT</b> Unclassified	<b>c. THIS PAGE</b> Unclassified			<b>19b. TELEPHONE NUMBER</b> ( <i>include area code</i> )			
			SAR	19				

(This page is intentionally blank.)

US ARMY DEVELOPMENTAL TEST COMMAND  
TEST OPERATIONS PROCEDURE

\*Test Operations Procedure 03-2-040  
DTIC AD No.

11 March 2021

BORESIGHT RETENTION

		<u>Page</u>
Paragraph	1. SCOPE.....	2
	2. FACILITIES AND INSTRUMENTATION.....	2
	2.1 Facilities .....	2
	2.2 Instrumentation.....	2
	3. REQUIRED TEST CONDITIONS.....	3
	4. TEST PROCEDURES .....	3
	4.1 Background .....	3
	4.2 Method.....	3
	5. DATA REQUIRED.....	5
	6. PRESENTATION OF DATA.....	5
	APPENDIX	A. ABBREVIATIONS.....
	B. REFERENCES.....	B-1
	C. APPROVAL AUTHORITY.....	C-1

1. SCOPE.

a. This Test Operations Procedure (TOP) outlines a procedure to test boresight retention on hand and shoulder fired weapons and machine guns, including crew served weapons and light automatic cannons up to 50 millimeters (mm) in caliber. Over the course of a weapon's life cycle, it is desirable for a weapon to maintain a consistent zero through the proper alignment between the weapon's bore and the sighting system. However, during testing the weapon sights and bore often become misaligned. The purpose of this TOP is to present a technique for measuring boresight retention for weapons that are not mounted on a vehicle/mobile platform, or that have been removed from a vehicle for isolated testing. This method of measuring boresight retention can be utilized on vehicle mounted weapon systems to isolate possible causes of boresight retention issues.

b. This test procedure is meant to help standardize testing and to aid the development of Detailed Test Plans (DTPs), Test and Evaluation Master Plans (TEMPs), and similar planning documents. This TOP does not constitute a requirement to do any of the specific tests nor does it serve to set performance or safety criteria for Army materiel. Actual requirements and criteria must come from requirements documents, contractual obligations, Army Regulations (ARs), etc.

2. FACILITIES AND INSTRUMENTATION.

2.1 Facilities.

<u>Item</u>	<u>Requirement</u>
Indoor testing facility	Protected environment for sensitive equipment.

2.2 Instrumentation.

<u>Item</u>	<u>Requirement</u>
Laser Bore Sight (LBS)	To locate the bore center (L3 Insight Borelight System AN/PEM-1).
Neutral density filter	To attenuate the laser (F-stop 4-8 typically used visible spectrum response).
Parabolic mirror	To redirect the laser to the imager (larger is better, 12 inch (in.) minimum, Focal Length (FL) 75 in. $\pm$ 1.5%, Reflectance 95% @ 450-600 nanometer, Backsurface - Ground, Coating - Enhanced Aluminum.
Mirror mount	Must allow for horizontal and vertical translation, and rotation of 0.03 in. per turn.

<u>Item</u>	<u>Requirement</u>
Goniometer stage	Must allow for horizontal and vertical translation and rotation, 0.5 mm per turn.
Neutral Density (ND) filter mount	To fix the neutral density filters.
Aiming Insert (fiducial)	To align optic crosshairs for reference and measurements. Insert is custom made. Consider multiple inserts to compliment specific test item. Fiducials should be sufficient in number to allow synchronization with the system under test (SUT) and resolvable with the SUT optic system (for instance visible versus Infrared (IR) spectrums).
Imager	Monochrome large format sensor camera. Minimum 1280 vs. 1024 pixels, 2/3 in. sensor, with global shutter.
Color camera with wide view lens	To view and capture optic crosshairs on fiducial (also known as see through) camera.

### 3. REQUIRED TEST CONDITIONS.

#### 3.1 Inspection and Servicing.

a. Ensure that all required system maintenance is performed in accordance with applicable Technical Manuals, Lubrication Orders, or other guidance documents.

b. Ensure that:

(1) All operating systems are up to proper speeds, and all systems are at normal operating temperatures (electro-optical and mechanical).

(2) All sensitive equipment is protected from harsh environments.

### 4. TEST PROCEDURES.

#### 4.1 Background.

The boresight retention test is performed over the life of a test article. Initially, the test article is baselined and then subjected to a test event. After the test event, the test article is tested for boresight retention and compared against the baseline.

#### 4.2 Method.

a. Setup instrumentation:

- (1) Ensure instrumentation is setup in a protected environment (indoors).
- (2) Ensure ND filters and Imager are in place to capture LBS light.
- (3) Ensure LBS is used in accordance with operating instructions. Utilize LBS in low power mode (class 1).
- (4) A depiction of the boresight retention setup is provided in Figure 1.

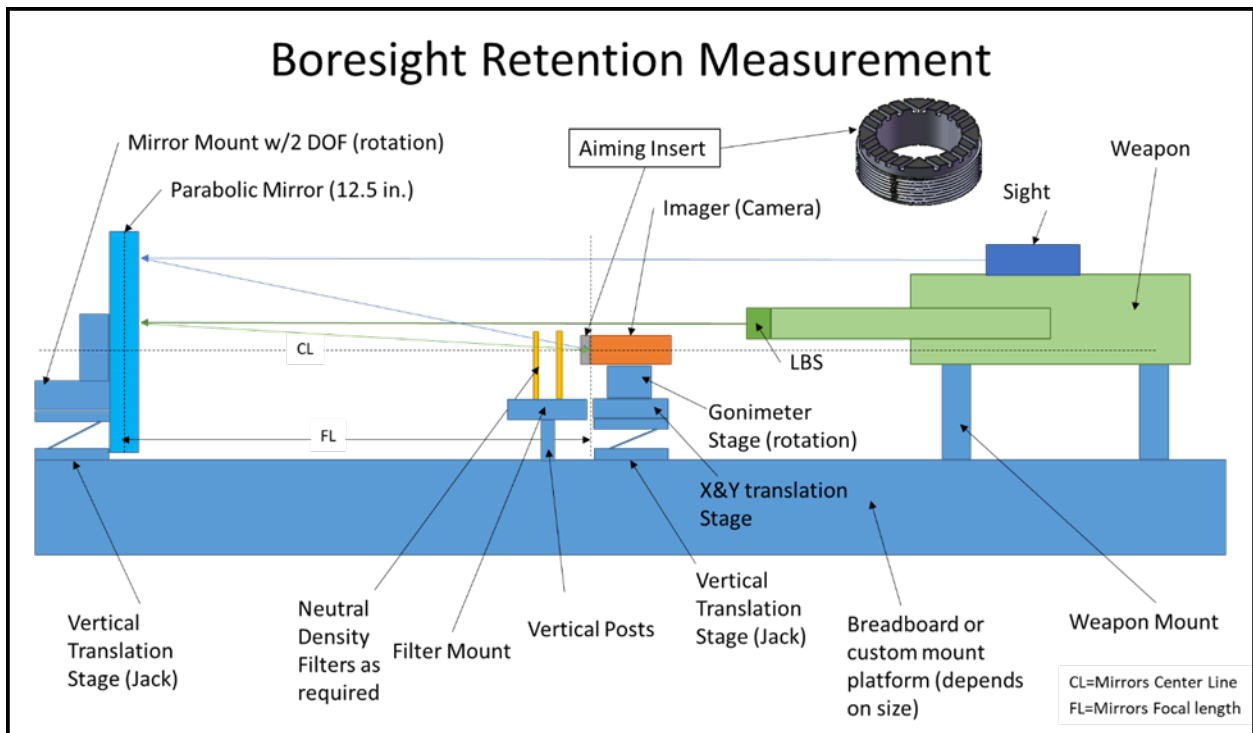

Figure 1. The boresight retention method.

b. Adjusting setup for test item:

- (1) Attach appropriate weapon mount.
- (2) Attach weapon with day optical sight with barrel perpendicular to mirror.
- (3) Insert LBS with appropriate mandrel and position at "0 degrees".

- (4) Attach ND filter to attenuate LBS beam energy if needed.
  - (5) Adjust mirror vertically until day optical sight and LBS trajectories are captured by parabola.
  - (6) Ensure LBS and day optical sight trajectories are perpendicular to parabola centerline (adjust rotation if need be).
  - (7) Adjust camera vertically until it is at centerline of parabola.
  - (8) Ensure camera is angled axially to centerline (adjust rotation if need be).
  - (9) Ensure camera is at focal length of parabola (FL) using X and Y translation controls.
- c. Collecting reference measurement:
- (1) Adjust LBS trajectory until beam is centered on camera detector.
  - (2) Capture image of LBS beam on camera detector (to determine X and Y coordinates).
  - (3) Without moving anything else, using viewfinder, wireless controls or see through camera (not pictured) adjust day optical sight (fixed reticle) until lines match up with aiming insert (note how it lines up. e.g. which line, which edge). See Figure 2.

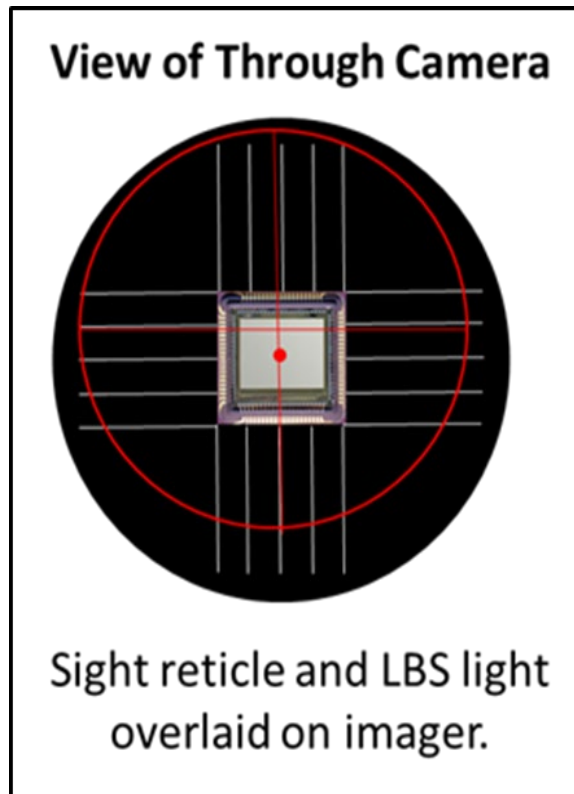

Figure 2. Image showing alignment of optical sight and aiming insert with respect to the LBS and image sensor.

- (4) Rotate LBS 90 degrees and take two images. Repeat for each of the four locations (0, 90, 180, 270 degrees) for a total of eight images.
  - (5) Test item is ready to undergo event.
- d. Collecting event measurement and calculating boresight retention value:
- (1) Event ends.
  - (2) Replace weapon system in test apparatus.
  - (3) Insert LBS.
  - (4) Ensure the optical sight's trajectory is aligned perpendicular to the mirror and imager after adjusting the focal length.
  - (5) Insert LBS w/appropriate mandrel and position at "0 degrees".

- (6) Capture image of LBS beam on camera detector (to determine X and Y coordinates).
- (7) Rotate LBS 90 degrees and take two images. Repeat for each of the four locations (0, 90, 180, 270 degrees) for a total of eight images.
- (8) Calculate centroids of divergence and reference measurement, as shown in Figure 3.

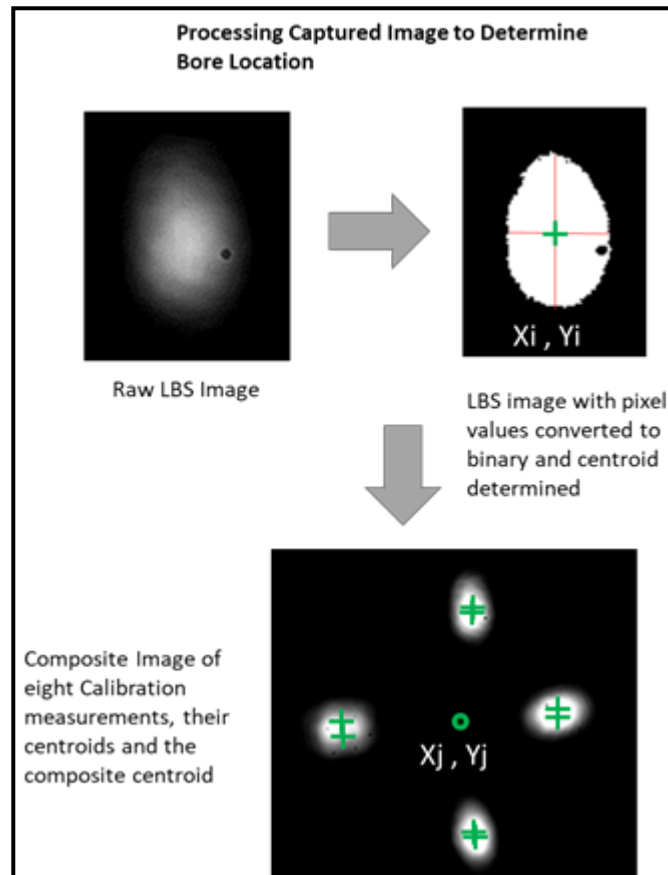

Figure 3. Diagram outlining how composite centroid is calculated from eight LBS images.

NOTES:

1. Calculate centroid of individual LBS images,  $X_i, Y_i$  using geometric decomposition.
2. The general formulas for geometric decomposition where  $X_i = C_x$  and  $Y_i = C_y$  are shown in Equation 1 and Equation 2.

$$C_x = \frac{\sum C_{ix} A_{ix}}{\sum A_{ix}} \quad (\text{Equation 1})$$

$$C_y = \frac{\sum C_{iy} A_{iy}}{\sum A_{iy}} \quad (\text{Equation 2})$$

where:

- $C_{ix}$  and  $C_{iy}$  are common shape centroids for X and Y dimensions (respectively).
- $A_{ix}$  and  $A_{iy}$  are the common shape areas for the X and Y dimensions (respectively).

NOTE: A mathematical solver and data collection suite such as National Instrument Corporation's LabVIEW software\*\* will provide more repeatable and timely solutions to the centroid calculations.

3. Use geometric decomposition again to solve for the composite centroid (all eight images).
- (9) Calculate boresight retention value, as shown in Figure 4.

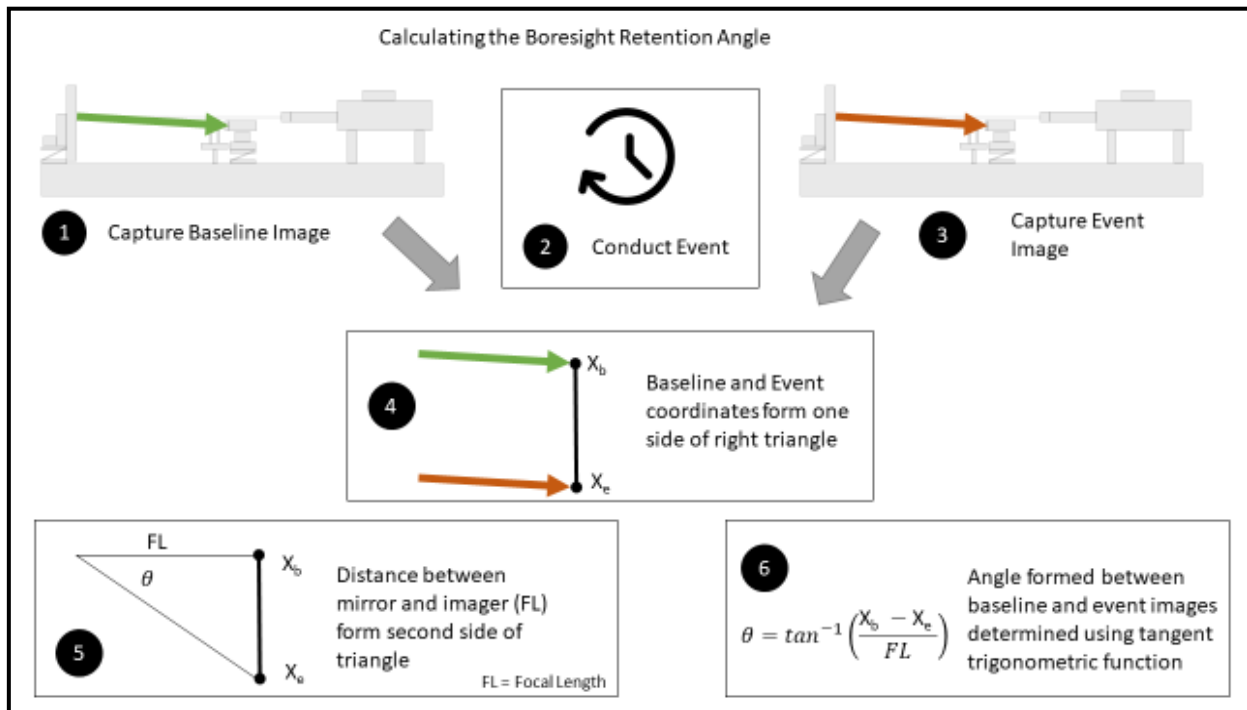

Figure 4. Overview of Boresight Retention Calculation Components.

\*\* The use of brand names does not constitute endorsement by the Army or any other agency of the Federal Government, nor does it imply that it is best suited for its intended application.

NOTES:

1. Calculate Boresight Retention angle in the X axis dimension using Equation 3.

$$\theta = \tan^{-1} \left( \frac{X_b - X_e}{FL} \right) \quad (\text{Equation 3})$$

where :

$\theta$  = Angle formed between baseline and event images.

$X_b$ =baseline X value.

$X_e$ =Event X value.

FL = Focal Length of Mirror used in measurement.

2. Calculate Boresight Retention angle in the Y axis dimension.

5. DATA REQUIRED.

- a. Image captures.
- b. Centroids of divergence and reference measurements.
- c. Weapon identification number.
- d. Ammunition lot number.
- e. Total number of rounds fired.
- f. Boresight retention data and values.
- g. All test incidents, categorized by class.
- h. Test setup photographs.
- i. LBS calibration date.
- j. LBS mandrel check date, if applicable.
- k. Weapon mount identification and details.

6. DATA PRESENTATION.

a. Present data in formats that is factual, comprehensive, and easy to understand. General guidance on presentation of data in reports is given in U.S. Army Test and Evaluation Command (ATEC) Pamphlet 73-1<sup>\*\*\*1</sup>; use this guidance for both printed and electronic presentations.

b. A table may be included to summarize test results showing reference measurements, calculations of centroids of divergences for each periodic test across the life of the test item. An example is provided in Table 1.

TABLE 1. EXAMPLE SUMMARY TABLE

System Under Test:				
Date:			Time:	
Baseline				
lb Measurement	X value	Y value	Centroid - X	Centroid - Y
1				
2				
3				
4				
5				
6				
7				
8				
Composite Centroid - X				
Composite Centroid - Y				
Event				
lb Measurement	X value	Y value	Centroid - X	Centroid - Y
1				
2				
3				
4				
5				
6				
7				
8				
Composite Centroid - X				
Composite Centroid - Y				
Mirror focal Length (FL):				
$\theta$ x:				
$\theta$ y:				

\*\*\* Superscript numbers correspond to Appendix B, References.

c. A graph may be included to illustrate visually how the boresight retention value changes over the life of the test item. An example is shown in Figure 5.

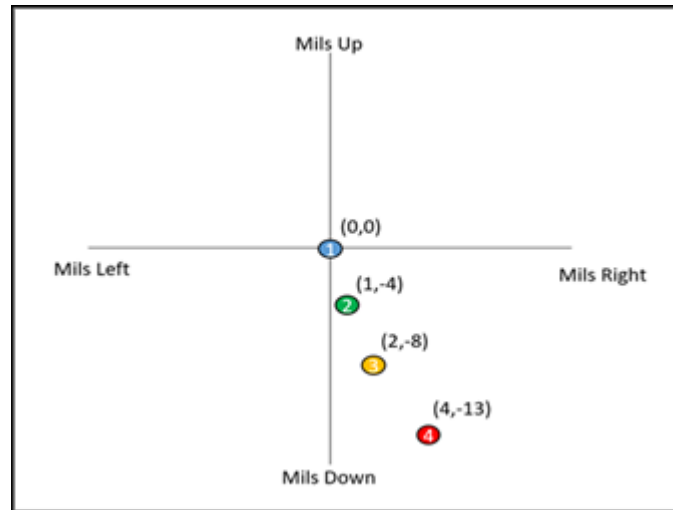

Figure 5. Example Summary Graph.

d. When applicable, test results shall be analyzed by suitable statistical procedures for comparing samples, for obtaining point or interval estimates of a parameter, and for determining from test results whether specific requirements have been satisfied. International Test Operations Procedure (ITOP) 03-1-005<sup>2</sup>, provides guidance on analyzing and presenting test results.

(This page is intentionally blank.)

APPENDIX A. ABBREVIATIONS.

AR	Army Regulation
ATEC	U.S. Army Test and Evaluation Command
DTP	Detailed Test Plan
FL	Focal Length
in.	inch
IR	infrared
ITOP	International Test Operations Procedure
LBS	Laser Bore Sight
mm	millimeter
ND	Neutral Density
SUT	system under test
TEMP	Test and Evaluation Master Plan
TOP	Test Operations Procedure

(This page is intentionally blank.)

APPENDIX B. REFERENCES.

1. ATEC Pamphlet 73-1, Test and Evaluation, System Test and Evaluation Procedures, 13 May 2019.
2. ITOP 03-1-005, Statistics for Test Assessment, 23 October 2003.

(This page is intentionally blank.)

APPENDIX C. APPROVAL AUTHORITY.

CSTE-CI

11 March 2021

MEMORANDUM FOR

Commander, U.S. Army Operational Test Command  
Director, U.S. Army Evaluation Center  
Commanders, ATEC Test Centers  
Technical Directors, ATEC Test Centers

SUBJECT: Test Operations Procedure 03-2-040, Boresight Retention, Approved for Publication

1. Test Operations Procedure (TOP) 03-2-040, Boresight Retention, has been reviewed by the U.S. Army Test and Evaluation Command (ATEC) Test Centers, the U.S. Army Operational Test Command, and the U.S. Army Evaluation Center. All comments received during the formal coordination period have been adjudicated by the preparing agency.
2. Scope of the document. This TOP contains one procedure for testing boresight retention of hand and shoulder fired weapons and machine guns including crew served weapons and light automatic cannons up to 50 millimeters in caliber. This method uses a parabolic mirror with a laser boresight to track changes over the test period of the weapon system.
3. This document is approved for publication and has been posted to the Reference Library of the ATEC Vision Digital Library System (VDLS). The VDLS website can be accessed at <https://vdls.atc.army.mil/>.
4. Comments, suggestions, or questions on this document should be addressed to U.S. Army Test and Evaluation Command (CSTE-CI), 6617 Aberdeen Boulevard-Third Floor, Aberdeen Proving Ground, MD 21005-5001; or e-mailed to [usarmy.apg.atec.mbx.atec-standards@mail.mil](mailto:usarmy.apg.atec.mbx.atec-standards@mail.mil).

ZWIEBEL, MICHAEL J.  
EL J. 1229197289

MICHAEL J. ZWIEBEL  
Director, Directorate for Capabilities  
Integration (DCI)

(This page is intentionally blank.)

Forward comments, recommended changes, or any pertinent data, which may be of use in improving this publication to the following address: Policy and Standardization Division (CSTE-CI-P), U.S. Army Test and Evaluation Command, 6617 Aberdeen Boulevard, Aberdeen Proving Ground, Maryland 21005-5001. Technical information may be obtained from the preparing activity: Small Arms Systems Division (TEDT-AT-FP-S), U.S. Army Aberdeen Test Center, 400 Colleran Road, Aberdeen Proving Ground, MD 21005-5059. Additional copies can be requested through the following website: <https://www.atec.army.mil/publications/documents.html>, or through the Defense Technical Information Center, 8725 John J. Kingman Rd., STE 0944, Fort Belvoir, VA 22060-6218. This document is identified by the accession number (AD No.) printed on the first page.