

REPORT DOCUMENTATION PAGE			Form Approved OMB No. 0704-0188		
Public reporting burden for this collection of information is estimated to average 1 hour per response, including the time for reviewing instructions, searching existing data sources, gathering and maintaining the data needed, and completing and reviewing this collection of information. Send comments regarding this burden estimate or any other aspect of this collection of information, including suggestions for reducing this burden to Department of Defense, Washington Headquarters Services, Directorate for Information Operations and Reports (0704-0188), 1215 Jefferson Davis Highway, Suite 1204, Arlington, VA 22202-4302. Respondents should be aware that notwithstanding any other provision of law, no person shall be subject to any penalty for failing to comply with a collection of information if it does not display a currently valid OMB control number. PLEASE DO NOT RETURN YOUR FORM TO THE ABOVE ADDRESS.					
1. REPORT DATE (DD-MM-YYYY) 15-11-2019		2. REPORT TYPE Technical		3. DATES COVERED (From - To) 15-11-2019	
4. TITLE AND SUBTITLE GVR Autonomy Payload Design Description Version A13			5a. CONTRACT NUMBER		
			5b. GRANT NUMBER		
			5c. PROGRAM ELEMENT NUMBER		
6. AUTHOR(S) Tyrus Valascho			5d. PROJECT NUMBER		
			5e. TASK NUMBER		
			5f. WORK UNIT NUMBER		
7. PERFORMING ORGANIZATION NAME(S) AND ADDRESS(ES) US Army, Ground Vehicle System Center (GVSC) Warren, MI 48397			8. PERFORMING ORGANIZATION REPORT		
9. SPONSORING / MONITORING AGENCY NAME(S) AND ADDRESS(ES) US Army, Ground Vehicle System Center (GVSC) Warren, MI 48397			10. SPONSOR/MONITOR'S ACRONYM(S)		
			11. SPONSOR/MONITOR'S REPORT NUMBER(S)		
12. DISTRIBUTION / AVAILABILITY STATEMENT DISTRIBUTION A. Approved for public release; distribution unlimited. OPSEC# OPSEC5011					
13. SUPPLEMENTARY NOTES The views, opinions, and/or findings contained in this report are those of the authors and should not be construed as an Official Department of the Army position, policy, or decision, unless so designated by other documents.					
14. ABSTRACT GVR Autonomy Payload is a sealed enclosure that houses processing and sensing devices intended for autonomous navigation, localization, and mapping. Design specifications, mounting pattern, troubleshooting, and related information is provided in this document.					
15. SUBJECT TERMS Autonomy, dismounted system, unmanned ground vehicle					
16. SECURITY CLASSIFICATION OF: Distr A			17. LIMITATION OF ABSTRACT None	18. NUMBER OF PAGES 17	19a. NAME OF RESPONSIBLE PERSON Tyrus Valascho
a. REPORT Distr A	b. ABSTRACT Distr A	c. THIS PAGE Distr A			19b. TELEPHONE NUMBER (include area code) (586) 459-7485



US Army - GVSC

GVR Autonomy Payload Design Description

Version A13



Tyrus Valascho
11-15-2019

Table of Contents

Description	3
Specifications	3
Sensors	3
Enclosure.....	3
Mounting.....	6
Basic Electrical Architecture.....	9
Software details	11
Network Addresses	12
IOP Connector	13
Troubleshooting.....	14

Description

The GVR Autonomy Payload is a sealed enclosure that houses processing and sensing devices intended for autonomous navigation, localization, and mapping.

This device is intended for Research and Development of autonomous behaviors for small and medium sized Unmanned Ground Vehicles (UGVs).

Specifications

The GVR Autonomy Payload designed to be sealed against moisture and dust to an IP67 (Ingress Protection 67) level. It has an expected ambient temperature operating range between -10 and +50 C.

The GVR Autonomy Payload will accept between 6 and 36 Volts Direct Current (VDC) as input. It will consume a maximum of 115 W of power. The IOP Connector is a MIL-DTL-38999 Series III Connector with Normal Orientation / Normal Key Rotation. This keying is for 24 VDC according to IOP v3.

Sensors

The GVR Autonomy Payload provides physical mounting, electrical power, and processing for one 3-D Lidar (16 line) and can optionally include a second Lidar. Additionally, it has provisions for physical mounting, electrical power, and processing for a visible light or depth camera.

An integrated Inertial Measurement Unit (IMU) is also included which provides 3 axes of acceleration data, 3 axes of gyroscopic data, and 3 axes of magnetometer data.

Enclosure

The enclosure of the GVR Autonomy Payload is designed as aluminum with either powder coat or paint for finish.

It consists of two parts - the upper enclosure and lower enclosure - as seen in Figure 1.

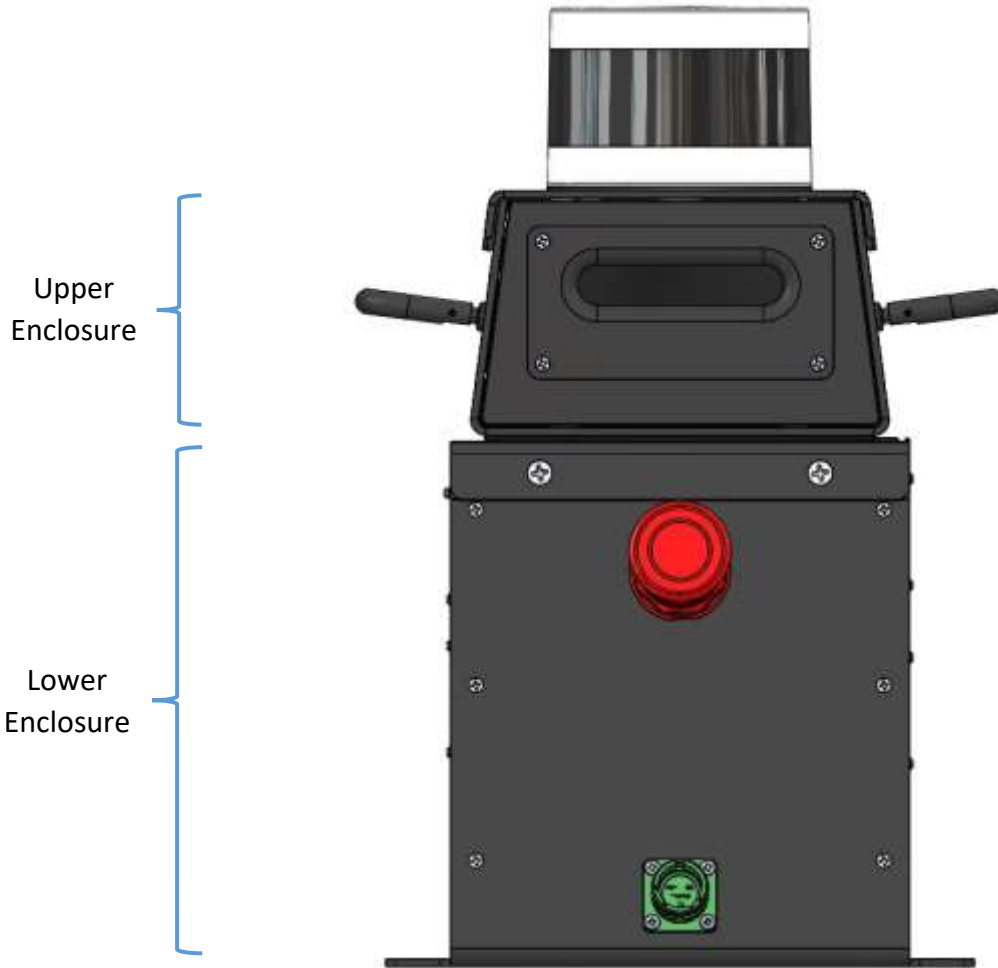

Figure 1 - Main parts of the GVR Autonomy Payload Enclosure

The lower enclosure holds most of the electrical components as well as the Emergency Stop and the IOP Connector. The Camera and Top Lidar are mounted to the upper enclosure but otherwise the wiring just passes through this part of the design.

The design is intended to be modular and the upper enclosure can be completely removed and replaced with a flat adapter plate if only the lower enclosure is needed. Contact the GVR Autonomy Payload team if this is desired.

The main mechanical components of the enclosure as seen from the front side are labelled in Figure 2.

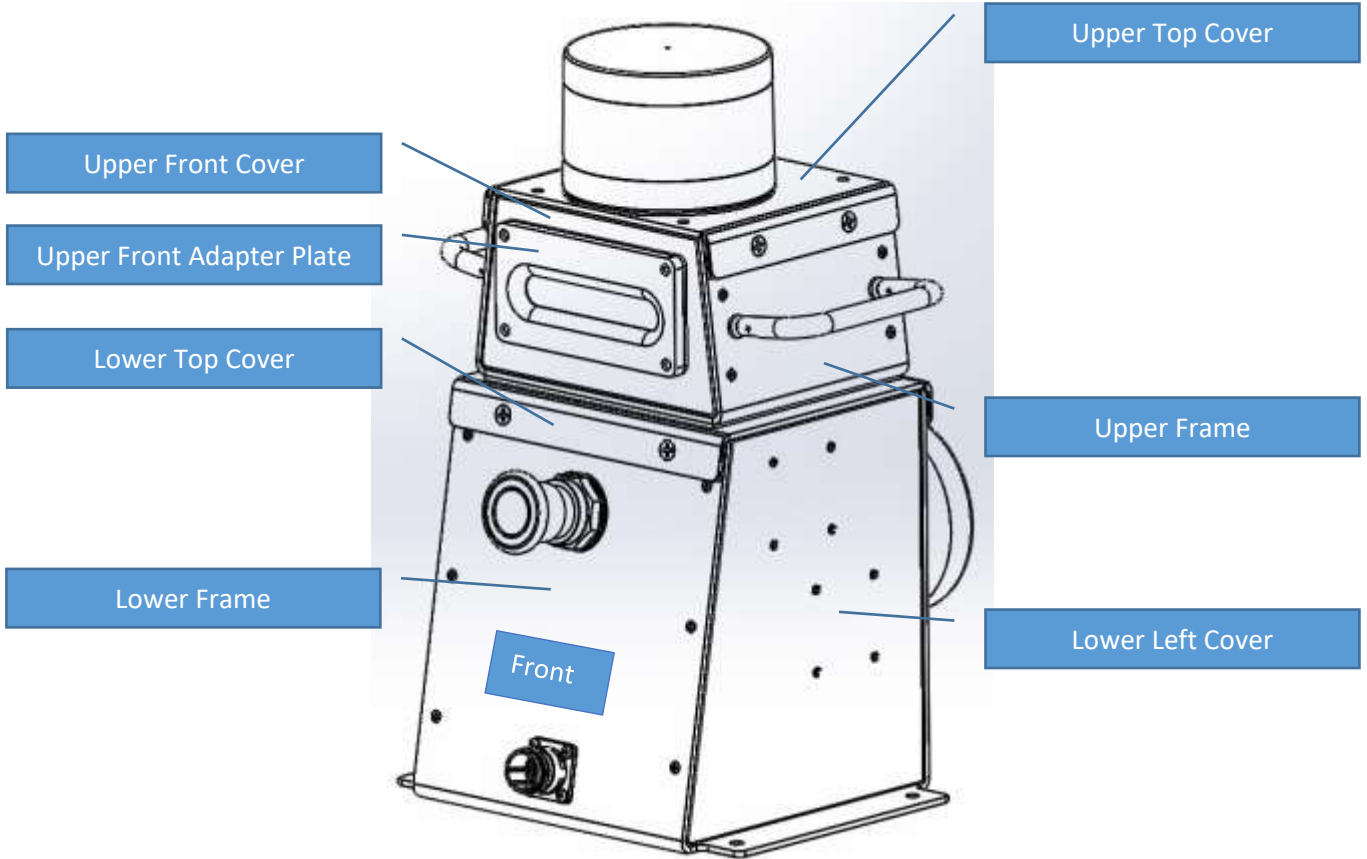

Figure 2 - Labelled Front Side of Enclosure

The rear of the enclosure with labelled mechanical components is shown in Figure 3.

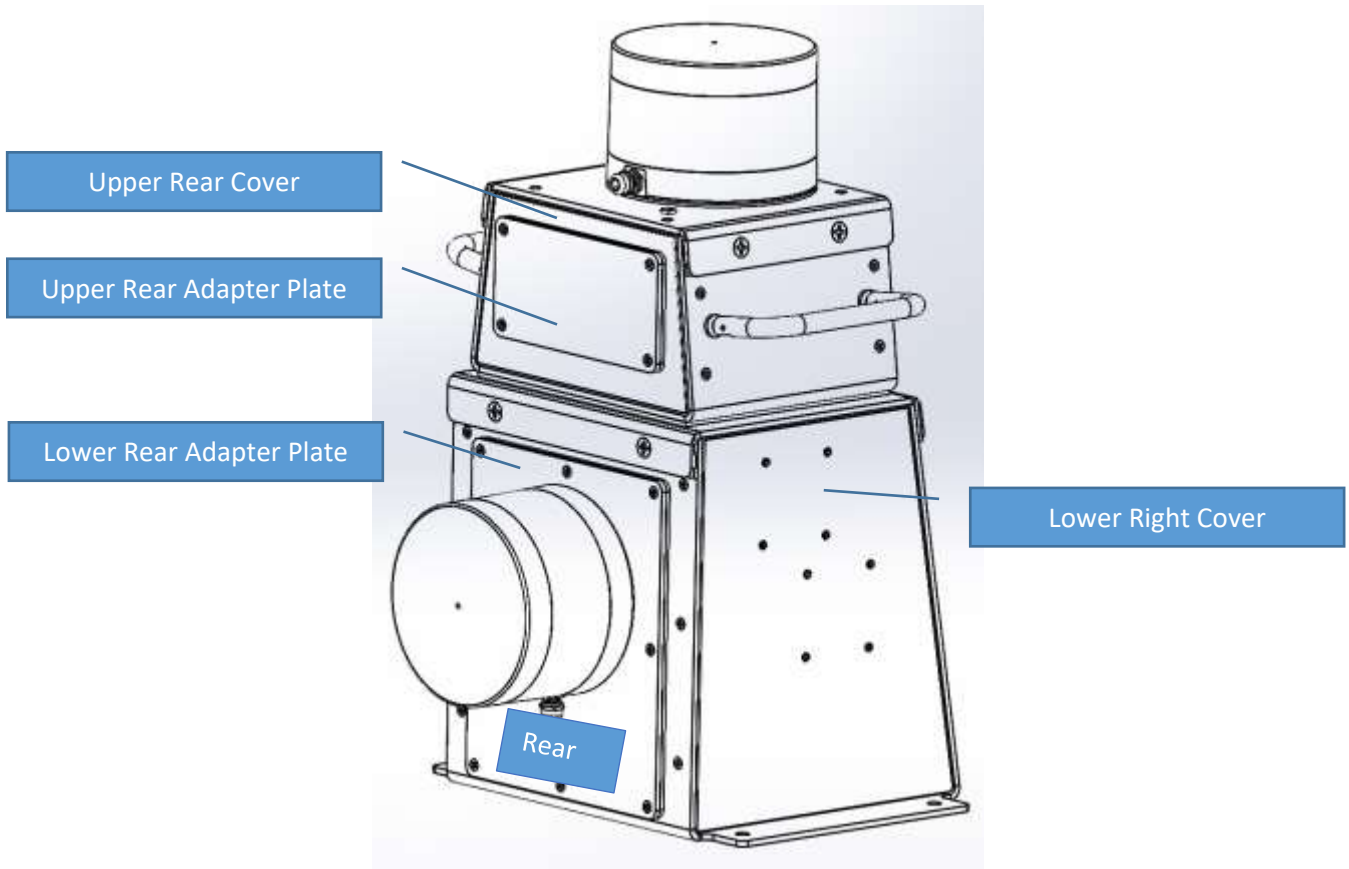

Figure 3 - Labelled Rear Side of Enclosure

Mounting

The GVR Autonomy Payload can be mounted using four $\frac{1}{4}$ -20 mounting screws, at least $\frac{1}{2}$ inch long (depending on depth of receiving threaded hole). It is intended to mount to an IOP-compliant mounting location, but could also mount to an appropriate optical bench as well.

The mounting pattern for the enclosure is provided in a “bottom up” view with dimensions in Figure 4.

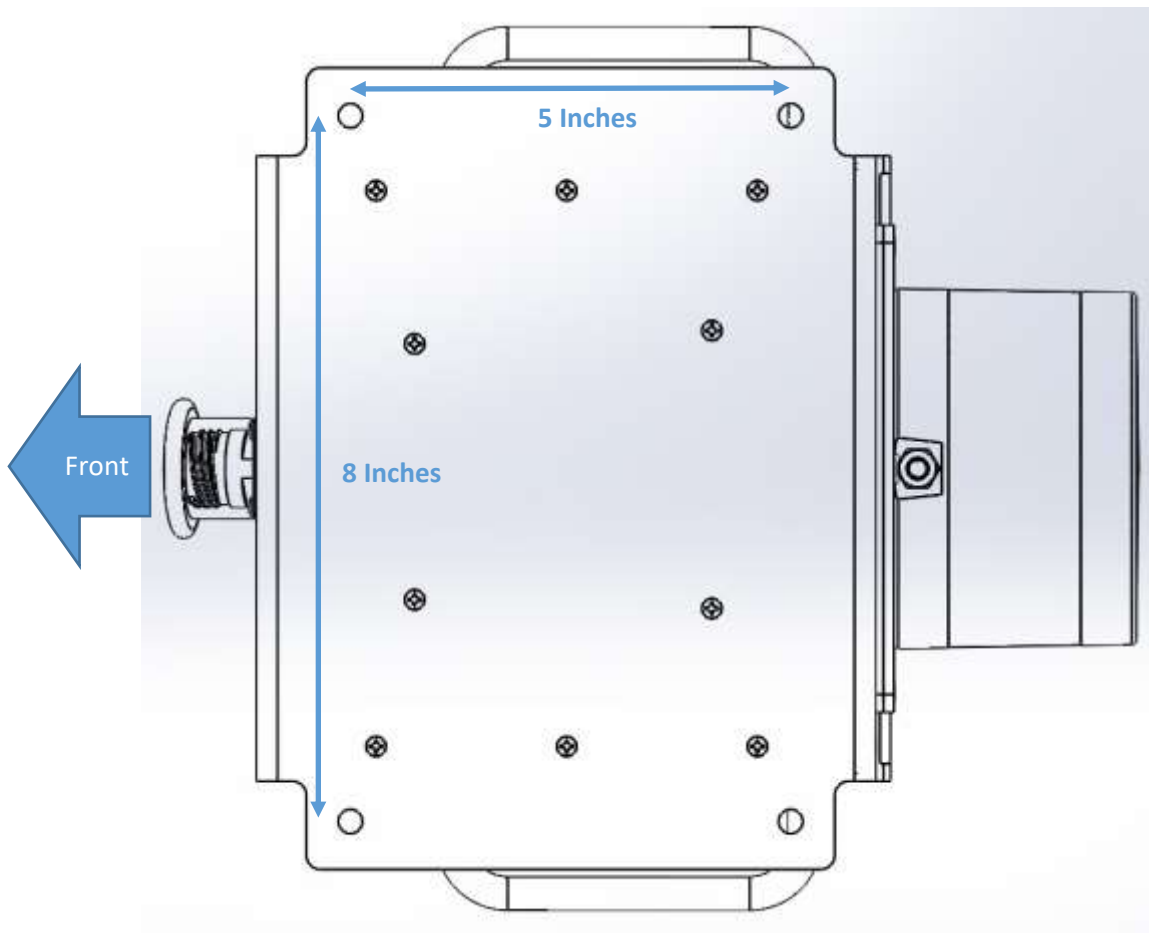

Figure 4 - View from Bottom of Enclosure

This mounting pattern is an 8 by 5 inch square with a ¼-20 through-hole mounting point centered at each corner. A typical integration configuration is provided in Figure 5, where four socket head screws are being used for mounting. Washers are recommended but not shown.

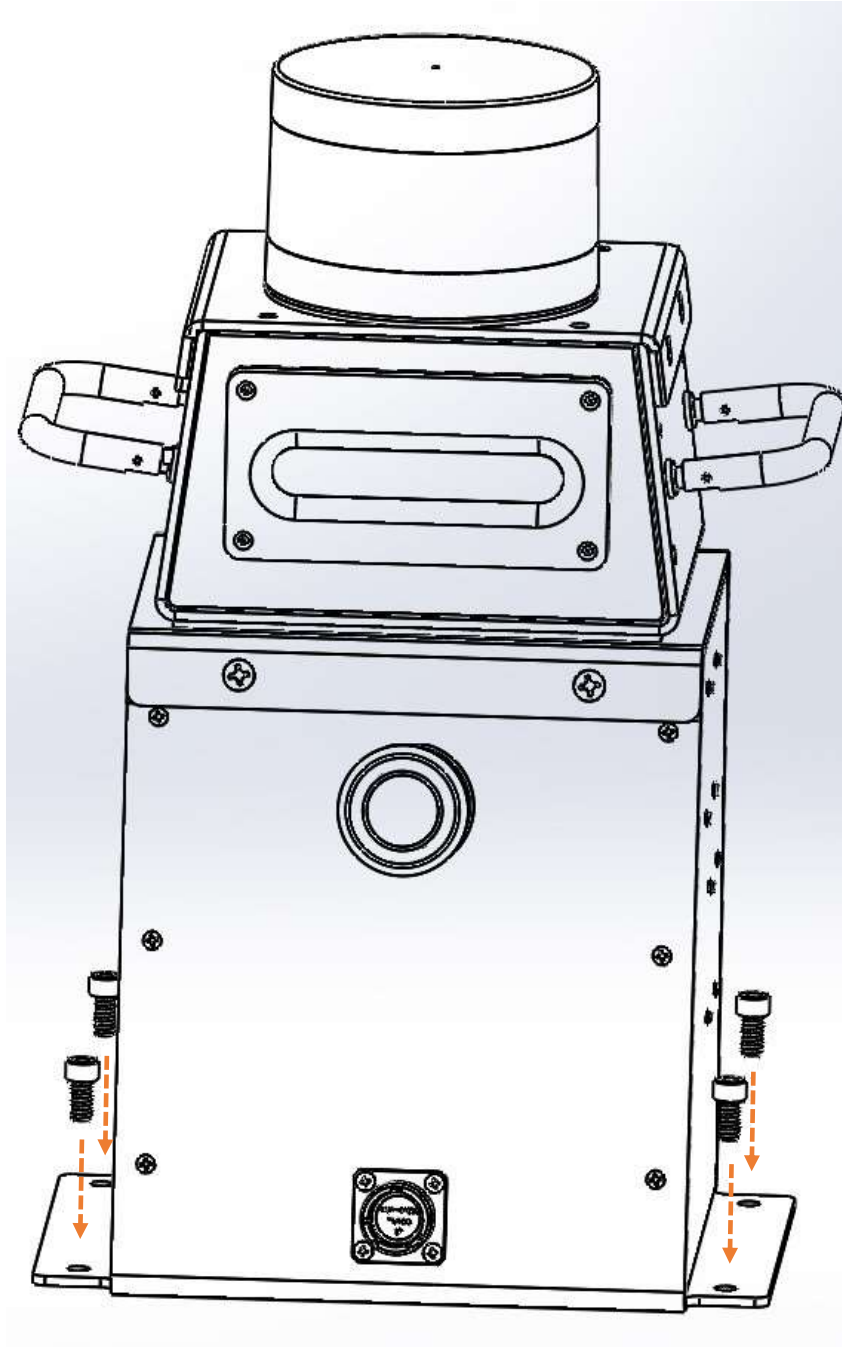

Figure 5 - Mounting a GVR Autonomy Payload with 4 Screws

Basic Electrical Architecture

Figure 6 is a block diagram of the connections between the main electrical components of the system.

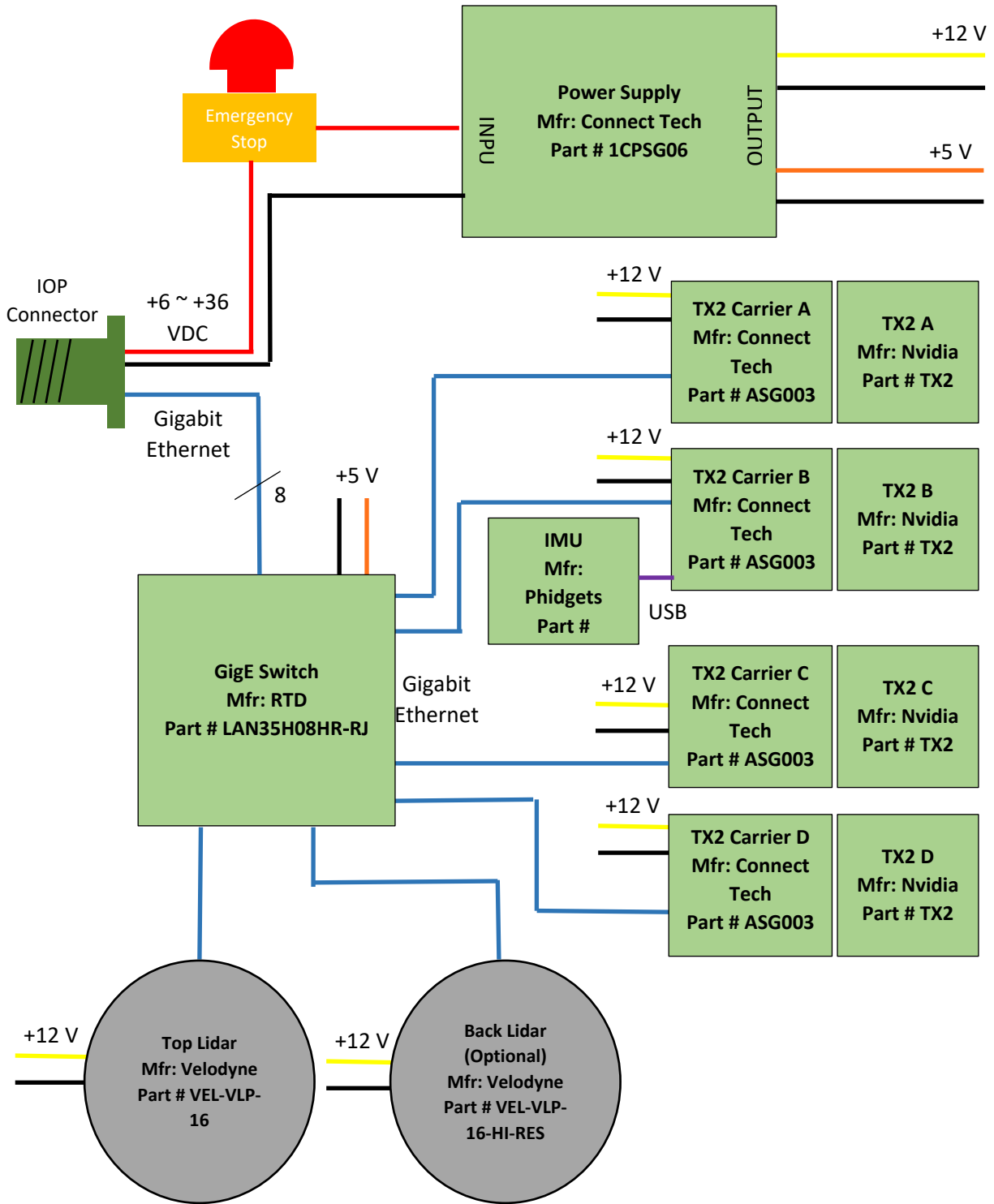

Figure 6 - Block Diagram of the Electrical System

Note that the GigE Switch has eight ports, 7 of which are occupied in this configuration. The 8th port can be used for a camera input or anything else that maybe needed.

The locations of the main electrical components of the enclosure are provided in Figure 7.

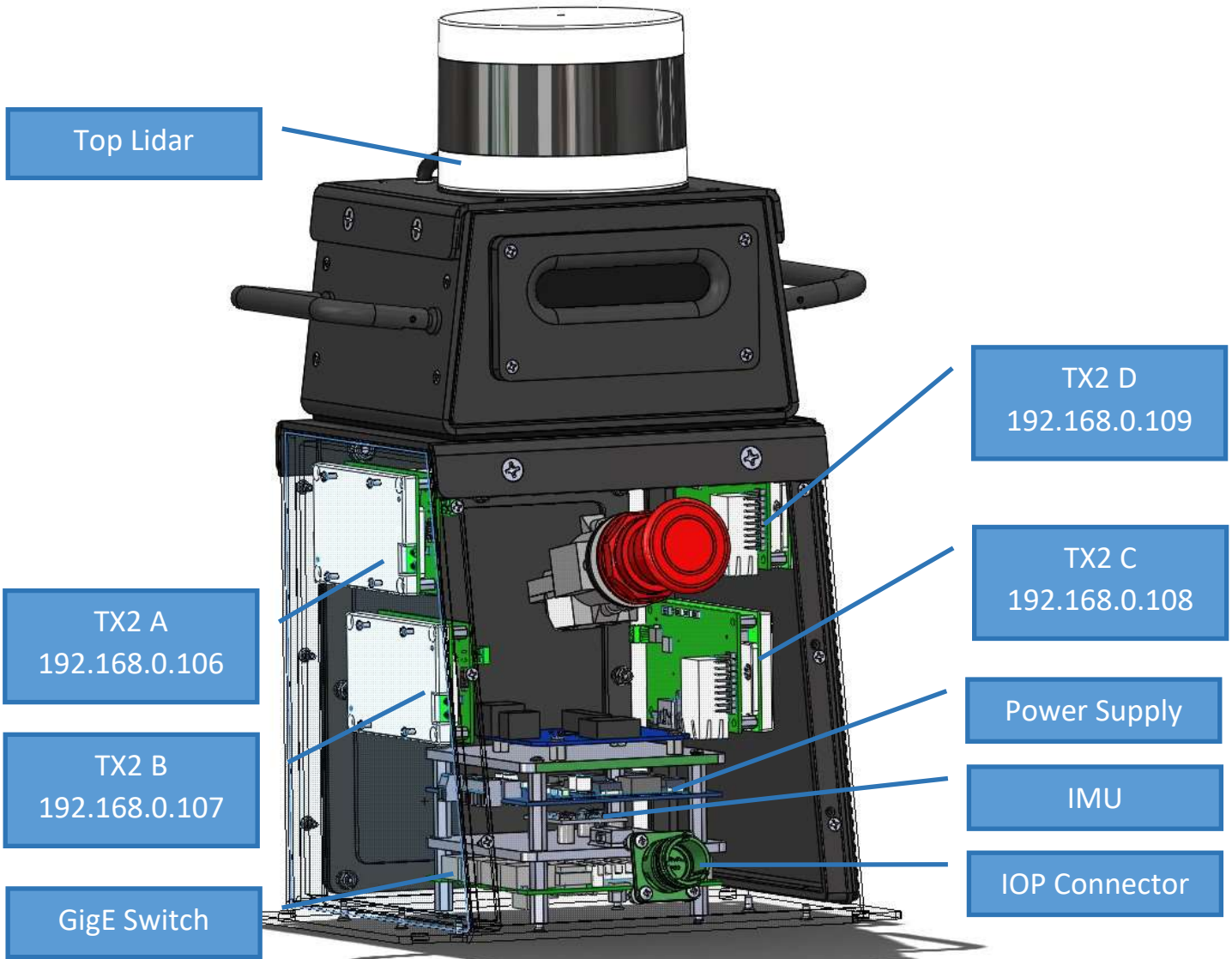

Figure 7 - Location of Main Components

Software details

Details

Linux: Ubuntu 18.04 LTS

Ros 1 Melodic

Login info for all TX2s:

Username: nvidia

Password: Random\$tring0505

Network Addresses

The IP addresses of the endpoints within the GVR Autonomy Payload are presented in Table 1.

Table 1 - IP Endpoint Addresses

Module	IP Address	Notes
TX2 A	192.168.0.106	
TX2 B	192.168.0.107	
TX2 C	192.168.0.108	
TX2 D	192.168.0.109	
Top (Horizontal) Lidar	192.168.0.20	
Back (Vertical) Lidar, if installed	192.168.0.21	
IP Camera, if installed	192.168.0.200	
IMU	N/A	Attached to TX2 B
Front USB Camera, if installed	N/A	Attached to TX2 C

The IMU is a Phidget 1044_0 sensor and connects to TX2 B via USB port. The IMU board is located equidistant from all three of the four ¼-20 mounting holes, with X, Y, and Z defined in Figure 8.

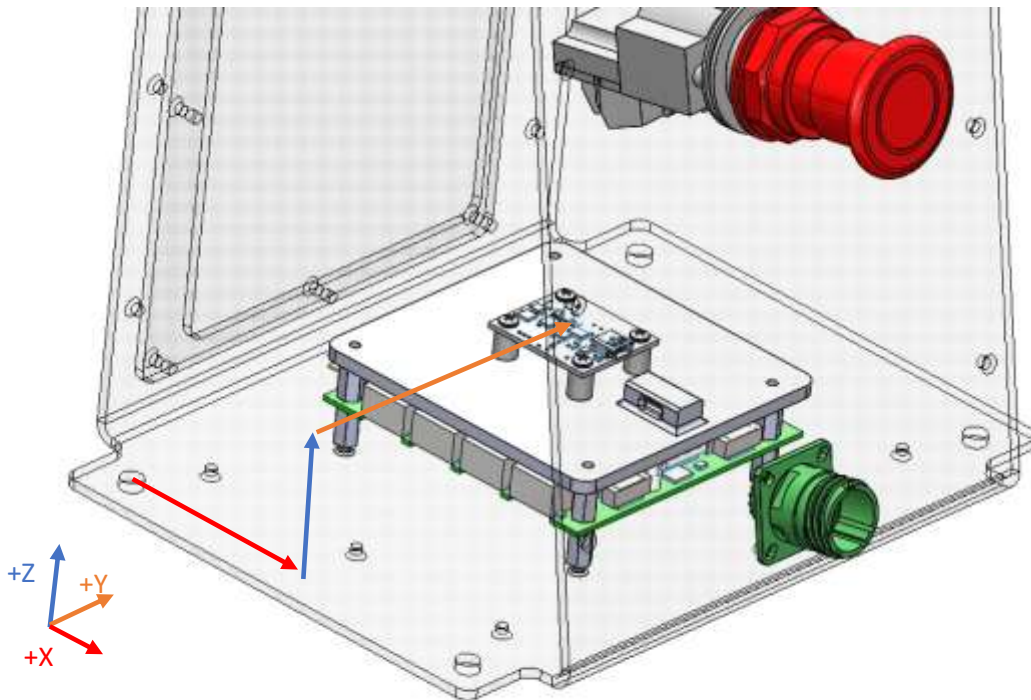

Figure 8 – Relative Location of IMU within the Enclosure

The location of the center of the IMU board from the right rear mounting point of the enclosure is:

X: 63.5 mm

Y: 101.6 mm

Z: 40.6 mm

Using the same reference point, the relative locations of all sensors are provided in Table 2.

Table 2 - Relative Sensor Locations from Right Rear Mounting Hole, in millimeters

Sensor	X location	Y location	Z location
Top (Horizontal) Lidar	62.2	101.6	338.3
Back (Vertical) Lidar, if installed	-64.7	101.6	110.0
IMU	63.5	101.6	40.6
Front Camera, if installed	103.9	101.6	264.4
Rear Camera, if installed	-12.5	101.6	264.4

IOP Connector

The input connector for the GVR Autonomy Payload is an IOP v3 Connector Interface B. The pinout of the connector is provided in Table 3.

Table 3 - IOP V3 Connector Interface B Pinout

Pin #	Signal	Pin #	Signal
1	A-	12	B+
2	C+	13	B-
3	C-	14	A+
4	Reserved	15	D-
5	PWR	16	Reserved
6	PWR	17	GND
7	PWR	18	GND
8	PWR	19	GND
9	PWR	20	Reserved
10	PWR	21	D+
11	Reserved	22	GND

Troubleshooting

Issue: Having a hard time communicating with any of the processors on the system.

Possible root cause: Velodyne Lidar sensor is set to broadcast its data

It could be the Velodyne VLP-16 Lidar is broadcasting data. Because this sensor is sending a lot of data continuously, it must not broadcast that data to the entire system. It could overwhelm the various processors and Ethernet endpoints on the system. For example, the Router on the GVR-BOT will become almost unresponsive if the Lidar is broadcasting.

Solution: Log into the sensor through a web browser and type in 192.168.0.20 in its navigation bar. The sensor screen will appear, which looks like this:

The screenshot shows the Velodyne LiDAR web interface. At the top, the sensor model is VLP-16, S/N is AE30112346, and MAC is 60-76-88-10-30-3a. Below this is the 'VLP-16 USER INTERFACE' with tabs for Configuration, System, Info, and Diagnostics. The Configuration tab is active, showing various settings:

- Laser: On Off
- Return Type: Dual (dropdown)
- Motor RPM: 300 (input) with +/- buttons and a Set button
- FOV Start: 0 (input) with +/- buttons and End: 359 (input) with +/- buttons and a Set button
- Phase Lock: On Off Offset: 0 (input) with +/- buttons and a Set button
- Host (Destination) IP: 255.255.255.255 Data Port: 2368 Telemetry Port: 8308 (input) with a Set button
- Network (Sensor) IP: 192.168.2.201 Mask: 255.255.255.0 Gateway: 192.168.2.1 DHCP: On Off (input) with a Set button

Buttons for 'Save Configuration' and 'Download Snapshot' are visible. At the bottom, there are status fields: GPS Position: [] PPS: Absent (input), Motor State: On (input) RPM: 300 (input) Lock: Off (input) Phase: 0 (input), and Laser State: On (input). The Velodyne LiDAR logo is in the bottom right corner.

Verify that the Host (Destination) IP is set to the endpoint for the Lidar data (192.168.0.107 in the base configuration). Also verify the Mask is set to 255.255.255.0.

Issue: None of the processors are responding.

Possible root cause: Broken or unplugged wire – either power or power ground

If none of the four processors respond to a ping, the most likely cause is something with the power system.

Solution:

The GVR Autonomy Payload should be plugged into a power source. A multimeter will be needed that can measure DC voltage and electrical continuity. Refer to trical components of the system for a block diagram of the electrical connections. An image of the various parts referred to in the following steps is provided in Figure 9.

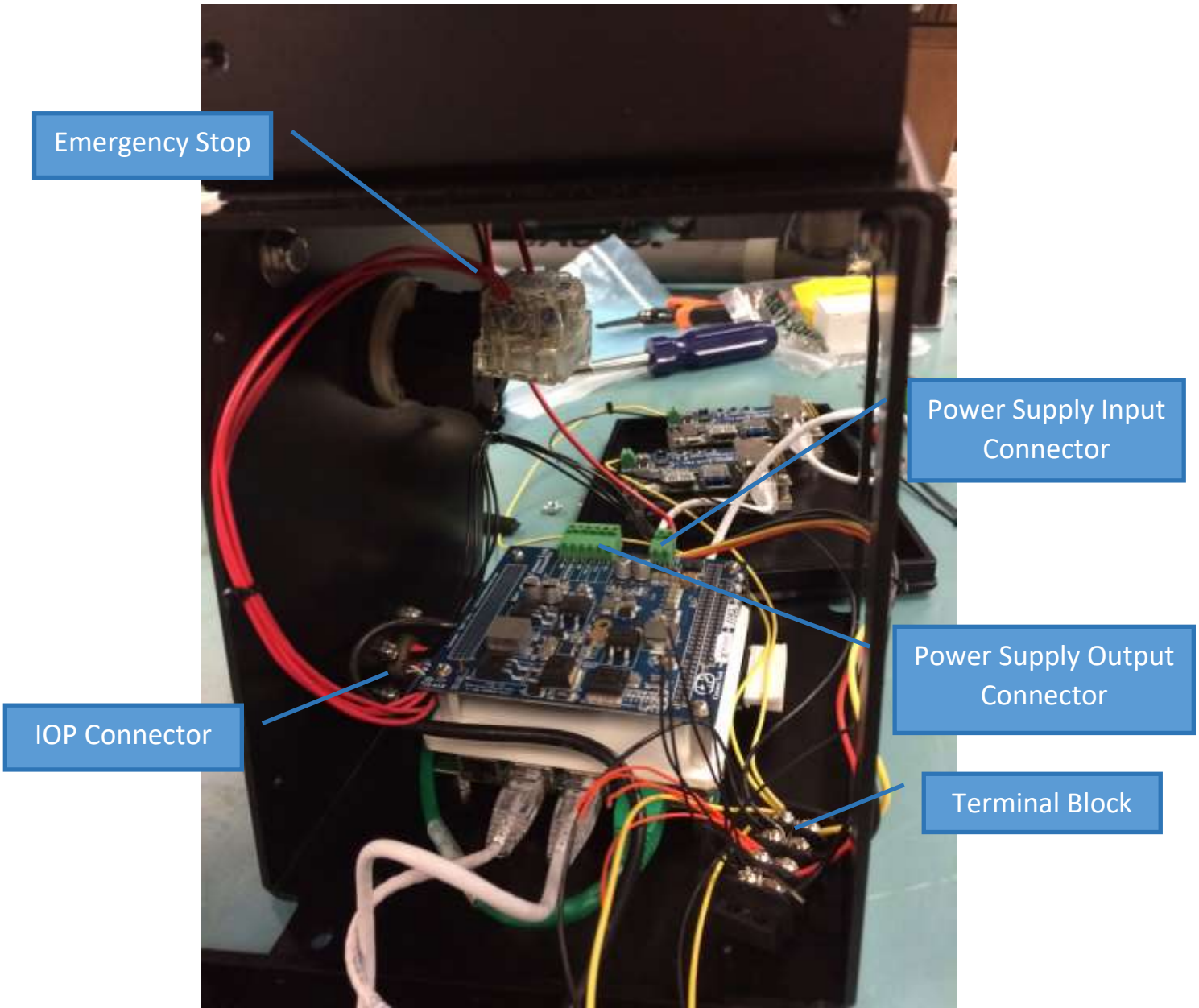

Figure 9 - Components to Troubleshoot Power Issues

1. Verify the input power to the system is correct. If connected to a GVR-BOT, it should be between 24 and 34 Volts VDC at the IOP Connector to the GVR Autonomy Payload. Measure the voltage between any 2 ground and power pins. Refer to Table 3 for the pinout. If no voltage is measured at this point, the system is not getting external power. If proper voltage is measured, proceed to the next step.
2. Open one or both of the two side plates of the enclosure. Verify the input power at the Emergency Stop. Press the mushroom button in until it locks. This opens the switch inside the Emergency Stop. The input side is terminal 1 and will have three red wires going into it. The output side should be terminal 2 and will have one red wire going into it. There should be between 24 and 34 VDC at the input side of the Emergency Stop when the switch is opened and

0 volts on the output side. If no voltage is present at the input side, the problem lies between the IOP Connector and the Emergency Stop. Examine the pins and connectors and measure the continuity at each point along the connection. If voltage is present at the input side of the Emergency Stop, proceed to the next step.

3. Release the Emergency Stop by twisting it clockwise and pulling the mushroom button out. This will close the switch. Between 24 and 34 VDC should be measured at the input and output side of the Emergency Stop when the switch is closed. If no voltage is measured at the output side of the Emergency Stop, the problem is a faulty Emergency Stop switch which must be replaced. If the correct voltage is present at the output side of the Emergency Stop, proceed to the next step.
4. Trace the red wire from the Emergency Stop to the Power Supply and measure the voltage across the two terminals at the 2-pin Power Supply Input Connector. If voltage between 24 and 34 VDC is not present at this connection, examine the black (ground) and red (power) wires from the Power Supply to their sources. Measure continuity and look at the connections to find the issue. If voltage is present at the Power Supply, but the lights of the Power Supply are not illuminated, replace the Power Supply. If voltage is present and the lights are illuminated, proceed to the next step.
5. The green 6-pin connector near the Input Connector of the Power Supply is the Output Connector. This connector provides 5 VDC regulated power (Orange wire) and 12 VDC regulated power (Yellow wire) to the rest of the system. Measure the 5 and 12 outputs (you may use either of the black (Ground) wires at the output as the ground) and verify the voltages are correct and stable with the output connector plugged into the Power Supply. If no voltage is present on either or both of the outputs, remove the Output Connector and measure these same voltages at the Power Supply. If the output voltages are correct at the Power Supply with the Output Connector removed, something connected to the output is shorting or grounding the output. This problem will need further troubleshooting – contact the GVR Autonomy Team. If the voltage is not present with output connector disconnected, the Power Supply itself has failed and should be replaced. If both voltages are correct at the output connector, proceed to the next step.
6. The two outputs of the Power Supply can be traced to a Terminal Block. Measure the input (the wires from the Power Supply) and output sides (the wires to the rest of the system) of the Terminal Block. If the output side of the Terminal Block does not show the correct voltages, the Terminal Block may have failed or there is another, unforeseen issue. Contact the GVR Autonomy Team.