



**NAVAL
POSTGRADUATE
SCHOOL**

MONTEREY, CALIFORNIA

**SYSTEMS ENGINEERING
CAPSTONE REPORT**

**ELECTROMAGNETIC RAILGUN CAPABILITIES
ON AMPHIBIOUS SHIPS**

by

Nelson S. Ciron, Adam J. Drake, Allan P. Guess,
and Caleb Schulte

September 2020

Advisor:

Co-Advisor:

Co-Advisor:

Eugene P. Paulo

Paul T. Beery

Wayne Porter

Approved for public release. Distribution is unlimited.

THIS PAGE INTENTIONALLY LEFT BLANK

REPORT DOCUMENTATION PAGE			<i>Form Approved OMB No. 0704-0188</i>
Public reporting burden for this collection of information is estimated to average 1 hour per response, including the time for reviewing instruction, searching existing data sources, gathering and maintaining the data needed, and completing and reviewing the collection of information. Send comments regarding this burden estimate or any other aspect of this collection of information, including suggestions for reducing this burden, to Washington headquarters Services, Directorate for Information Operations and Reports, 1215 Jefferson Davis Highway, Suite 1204, Arlington, VA 22202-4302, and to the Office of Management and Budget, Paperwork Reduction Project (0704-0188) Washington, DC 20503.			
1. AGENCY USE ONLY (Leave blank)	2. REPORT DATE September 2020	3. REPORT TYPE AND DATES COVERED Systems Engineering Capstone Report	
4. TITLE AND SUBTITLE ELECTROMAGNETIC RAILGUN CAPABILITIES ON AMPHIBIOUS SHIPS			5. FUNDING NUMBERS
6. AUTHOR(S) Nelson S. Ciron, Adam J. Drake, Allan P. Guess, and Caleb Schulte			
7. PERFORMING ORGANIZATION NAME(S) AND ADDRESS(ES) Naval Postgraduate School Monterey, CA 93943-5000			8. PERFORMING ORGANIZATION REPORT NUMBER
9. SPONSORING / MONITORING AGENCY NAME(S) AND ADDRESS(ES) N/A			10. SPONSORING / MONITORING AGENCY REPORT NUMBER
11. SUPPLEMENTARY NOTES The views expressed in this thesis are those of the author and do not reflect the official policy or position of the Department of Defense or the U.S. Government.			
12a. DISTRIBUTION / AVAILABILITY STATEMENT Approved for public release. Distribution is unlimited.			12b. DISTRIBUTION CODE A
13. ABSTRACT (maximum 200 words) An electromagnetic railgun (EMRG) is a developmental weapon that utilizes electromagnetic propulsion to launch kinetic projectile attacks against air, sea, and land targets. This new propulsion technology differs from the current arsenal of naval weapons that utilize chemical missile propulsion and are limited in magazine depth. This study explores the feasibility of using an EMRG in an amphibious assault mission to retake control of a captured island's military base. A naval scenario was simulated in a force-on-force skirmish with various amphibious task force options that included the EMRG weapon in unique configurations. The addition of this weapon showed a significant increase in operational performance over established force compositions based on determined measures of effectiveness and performance. Regression analysis of the results provided high repeatability and reliability factors that verified the operational benefits of the EMRG. Magazine depth, cycle time between rounds, and hit probability proved to be the most important characteristics of the EMRG weapon when conducting an amphibious assault mission. Further technology maturation and naval ship integration are recommended to deploy the EMRG weapon as a capability improvement for future naval missions.			
14. SUBJECT TERMS electromagnetic railgun, EMRG, littoral operations in a contested environment, expeditionary advanced base operations			15. NUMBER OF PAGES 105
			16. PRICE CODE
17. SECURITY CLASSIFICATION OF REPORT Unclassified	18. SECURITY CLASSIFICATION OF THIS PAGE Unclassified	19. SECURITY CLASSIFICATION OF ABSTRACT Unclassified	20. LIMITATION OF ABSTRACT UU

THIS PAGE INTENTIONALLY LEFT BLANK

Approved for public release. Distribution is unlimited.

ELECTROMAGNETIC RAILGUN CAPABILITIES ON AMPHIBIOUS SHIPS

Nelson S. Ciron, Adam J. Drake, Allan P. Guess, and Caleb Schulte

Submitted in partial fulfillment of the
requirements for the degrees of

MASTER OF SCIENCE IN SYSTEMS ENGINEERING

and

MASTER OF SCIENCE IN ENGINEERING SYSTEMS

from the

**NAVAL POSTGRADUATE SCHOOL
September 2020**

Lead Editor: Adam J. Drake

Reviewed by:
Eugene P. Paulo
Advisor

Paul T. Beery
Co-Advisor

Wayne Porter
Co-Advisor

Accepted by:
Ronald E. Giachetti
Chair, Department of Systems Engineering

THIS PAGE INTENTIONALLY LEFT BLANK

ABSTRACT

An electromagnetic railgun (EMRG) is a developmental weapon that utilizes electromagnetic propulsion to launch kinetic projectile attacks against air, sea, and land targets. This new propulsion technology differs from the current arsenal of naval weapons that utilize chemical missile propulsion and are limited in magazine depth. This study explores the feasibility of using an EMRG in an amphibious assault mission to retake control of a captured island's military base. A naval scenario was simulated in a force-on-force skirmish with various amphibious task force options that included the EMRG weapon in unique configurations. The addition of this weapon showed a significant increase in operational performance over established force compositions based on determined measures of effectiveness and performance. Regression analysis of the results provided high repeatability and reliability factors that verified the operational benefits of the EMRG. Magazine depth, cycle time between rounds, and hit probability proved to be the most important characteristics of the EMRG weapon when conducting an amphibious assault mission. Further technology maturation and naval ship integration are recommended to deploy the EMRG weapon as a capability improvement for future naval missions.

THIS PAGE INTENTIONALLY LEFT BLANK

TABLE OF CONTENTS

I.	INTRODUCTION.....	1
A.	BACKGROUND	1
B.	RELATED RESEARCH	2
1.	A2 / AD.....	2
2.	EABO	2
3.	CURRENT NAVAL WEAPON SYSTEMS.....	3
4.	DEVELOPMENTAL WEAPONS	3
C.	PROBLEM STATEMENT	5
D.	SYSTEMS ENGINEERING PROCESS.....	6
E.	RESEARCH OBJECTIVES	8
F.	INTRODUCTION SUMMARY	9
II.	CAPABILITIES ANALYSIS.....	11
A.	STAKEHOLDER ANALYSIS	11
B.	FUNCTIONAL ANALYSIS	13
C.	OPERATIONAL ANALYSIS.....	17
III.	MODELING AND SIMULATION	21
A.	INTRODUCTION.....	21
B.	ASSUMPTIONS AND CONSTRAINTS	24
C.	COURSE OF ACTION DEFINITION	27
D.	SIMULATION INPUTS.....	30
E.	ATF COMPOSITIONS AND SIMULATION VARIATIONS	34
1.	COURSE OF ACTION 1—CONCEPTUAL EABO	35
2.	COURSE OF ACTION 2—GAME CHANGER	35
3.	COURSE OF ACTION 3—NO ESCORT	36
4.	COURSE OF ACTION 4—COMMAND AND CONTROL	36
5.	COURSE OF ACTION 5—C2-E2	37
6.	MISSION PLANNING SUMMARY.....	37
IV.	RESULTS	39
A.	DESIGN OF EXPERIMENTS	39
B.	REGRESSION ANALYSIS	45
C.	COA1 BASELINE SIMULATION	48
D.	COA3 MISSION DESIGN AND ANALYSIS	50

V.	CONCLUSIONS	57
A.	PROJECT FINDINGS	57
B.	RECOMMENDATIONS.....	58
C.	FUTURE RESEARCH TOPICS	60
	1. EMRG INTEGRATION	60
	2. EMRG LIMITATIONS WITH SUBSYSTEMS.....	61
	3. MODELING AND SIMULATION IMPROVEMENTS	61
	4. FUTURE RESEARCH SUMMARY.....	62
	APPENDIX A. EXTENSIM 10 MODEL.....	63
	A. PHASE A—INITIAL FIRING MISSION OR PREPERATION OF THE LANDING AREA BY SUPPORTING ARMS.....	63
	B. PHASE B—ATF ARRIVAL AT THE OUTER AND INNER TRANSPORT AREA AND BUILDUP OF LANDING FORCE	69
	C. PHASE C—DISABLING HARDENED MISSILE SITES AND OBTAINING THE OBJECTIVE.....	72
	APPENDIX B. REGRESSION ANALYSIS SIGNIFICANT FACTORS	75
	LIST OF REFERENCES.....	79
	INITIAL DISTRIBUTION LIST	81

LIST OF FIGURES

Figure 1.	Core EMRG Components and Science. Source: Bennett (2016).	4
Figure 2.	Systems Engineering Method, Modified Vee Adapted from Beery and Paulo (2019).	7
Figure 3.	Functional Hierarchy of EABO Mission	13
Figure 4.	System Input-Output Diagram	16
Figure 5.	High-Level Operational Concept of an ATF Assault Launched from an EAB	19
Figure 6.	Amphibious Assault Mission Phases	22
Figure 7.	Sea Areas (JP3-02).....	23
Figure 8.	Modeling and Simulation Context Chart	25
Figure 9.	Phase A—Prepare Landing Location.....	28
Figure 10.	Phase B—Launch Landing Forces.....	29
Figure 11.	Phase C—Landing Force Secures Location	30
Figure 12.	LPD-E Operational Sequence in Phase B	36
Figure 13.	Mean Values for Observed Responses at Low Enemy Concentration	42
Figure 14.	Mean Values for Observed Responses at Medium Enemy Concentration	43
Figure 15.	Mean Values for Observed Responses at High Enemy Concentration.....	44
Figure 16.	COA4 (High Enemy Concentration) Predicted versus Actual Response for % Missiles Destroyed	46
Figure 17.	COA4 (High Enemy Concentration) Residual Plot for % Missiles Destroyed	47
Figure 18.	COA3 (High Enemy Concentration) Predicted and Residual Plots for # Targets Destroyed	48
Figure 19.	COA5 (High Enemy Concentration) Predicted and Residual Plots for # Targets Destroyed	48

Figure 20.	COA1 (Medium Enemy Concentration) Input Factor Prediction Profiler for Desired Responses	49
Figure 21.	COA1 (High Enemy Concentration) Input Factor Prediction Profiler for Desired Responses.....	50
Figure 22.	COA3 (Medium Enemy Concentration) Significant Factors for # Targets Destroyed	51
Figure 23.	COA3 (Medium Enemy Concentration) Input Factor Prediction Profiler for Desired Responses	53
Figure 24.	COA3 (High Enemy Concentration) Input Factor Prediction Profiler for Desired Responses.....	54
Figure 25.	Creation of Initial Firing Mission with Ability to Output time of Completion.....	63
Figure 26.	Enemy Targets Initialized and the COA or ATF Configuration Applied.....	64
Figure 27.	Determines Ship or Weapon Availability for Engaging Enemy Targets.....	64
Figure 28.	Enemy Missiles Created and Fired Upon the ATF.....	65
Figure 29.	Targeting Queue Delay Time and Rounds Checked for the LPD-E and the LPD-E-C2.....	65
Figure 30.	LPD-E-C2 Engagement with Ground and Missile Targets	66
Figure 31.	LPD-E-C2 Firing and Missed Shot Process.....	66
Figure 32.	LPD-E-C2 Target Hits Sorted by Type with Calculations for Response Time and Disable Time from Initial Response.....	67
Figure 33.	ATF Checked for Hit or Miss by Leaked Enemy Missiles.....	68
Figure 34.	Start Time Calculated for Phase B or Landing Force Deployment	69
Figure 35.	AAV Deployment Process	69
Figure 36.	LCAC Deployment Process	70
Figure 37.	MV-22 Deployment Process.....	71
Figure 38.	Buildup of Friendly Landing Force	72

Figure 39.	Calls for Fire to Assist with Disabling Enemy Hardened Missile or Coastal Defense Sites.....	73
Figure 40.	Calls for Fire against Hardened Objectives	74
Figure 41.	COA3 (Medium Enemy Concentration) Significant Factors for # Targets Destroyed	75
Figure 42.	COA3 (Medium Enemy Concentration) Significant Factors for % Missiles Destroyed.....	75
Figure 43.	COA3 (Medium Enemy Concentration) Significant Factors for # ATF Ships Sunk.....	76
Figure 44.	COA3 (High Enemy Concentration) Significant Factors for # Targets Destroyed	76
Figure 45.	COA3 (High Enemy Concentration) Significant Factors for % Missiles Destroyed.....	76
Figure 46.	COA3 (High Enemy Concentration) Significant Factors for # ATF Ships Sunk	77

THIS PAGE INTENTIONALLY LEFT BLANK

LIST OF TABLES

Table 1.	LPD Capability Gaps and EMRG Benefits and Projected Results.....	8
Table 2.	Stakeholder Analysis Matrix.....	12
Table 3.	Measures of Effectiveness (MOEs) and Measures of Performance (MOPs).....	16
Table 4.	Simulation Assumptions.....	25
Table 5.	ATF Model and Simulation Inputs.....	31
Table 6.	Enemy Strength Parameters.....	33
Table 7.	Simulation Amphibious Task Force Loadouts.....	34
Table 8.	Comparison Points between Simulated COAs.....	37
Table 9.	DOE Input Factors.....	40
Table 10.	DOE Observed Responses.....	40
Table 11.	Mean Values for Observed Responses.....	41
Table 12.	R ² values for observed responses.....	45
Table 13.	COA1 Mean Values for Observed Responses for Large Multirun Simulations.....	50
Table 14.	R ² Values for COA3 Refined Regression Models.....	52
Table 15.	COA3 (Medium Enemy Concentration) Input Factor Values for Large Multirun Simulation.....	53
Table 16.	COA3 (High Enemy Concentration) Input Factor Values for Large Multirun Simulation.....	54
Table 17.	COA3 Mean Values for Observed Responses for Large Multirun Simulations.....	55
Table 18.	Results for Measures of Effectiveness.....	55

THIS PAGE INTENTIONALLY LEFT BLANK

LIST OF ACRONYMS AND ABBREVIATIONS

A2/AD	anti-access/area denial
AAV	assault amphibious vehicles
AA-W	anti-air warfare
AGS	advanced gun system
AOA	amphibious objective area
ATF	amphibious task force
BIC	Bayesian information criteria
C2	command and control
CIWS	close-in weapon systems
CL	confidence level
CLA	cushion launch area
CLZ	cushion landing zone
COA	course of action
CONOPS	concept of operations
DDG	guided missile destroyer
DL	distributed lethality
DOE	design of experiments
EAB	expeditionary advanced bases
EABO	expeditionary advanced base operations
EMRG	electromagnetic railgun
ISR	intelligence, surveillance, and reconnaissance
LCAC	landing craft air cushions
LF	landing force
LHA	landing helicopter assault
LOCE	littoral operations in a contested environment
LOD	line of departure
LPD	landing platform dock
LPD-E	landing platform dock equipped with electromagnetic railgun

LSD	landing ship dock
MAGTF	marine air ground task force
MBSE	model-based systems engineering
MCM	mine countermeasures
MEU	military expeditionary unit
MOE	measures of effectiveness
MOP	measures of performance
NECC	Naval Expeditionary Combat Command
NOB	nearly orthogonal nearly balanced
NSFS	naval surface fire support
O&M	operators and maintainers
ONR	Office of Naval Research
PMP	project management plan
SAG	surface action group
SAM	surface-to-air missiles
SSM	surface-to-surface missiles
TLAM	Tomahawk land attack missiles
UAV	unmanned aerial vehicles
VLS	vertical launch system

EXECUTIVE SUMMARY

This capstone report focuses on the operational benefits of an electromagnetic railgun (EMRG) by applying this weapon in an amphibious task force (ATF) mission to retake a partner nation's island. The EMRG is a developmental weapon that utilizes electromagnetic propulsion to launch projectiles for long-range attacks against air, sea, and land targets. This new propulsion technology differs from the current arsenal of naval weapons that utilize volatile chemical rocket propulsion that are expensive with a limited number of carried missiles per ship. While the EMRG is still considered a developmental weapon, recent prototypes and initial testing results indicate that a 32 mega-joule EMRG could launch projectiles at a rate of ten rounds per minute for an approximate maximum distance of 100 nautical miles (O'Rourke 2019). This new weapon could greatly extend the capability of amphibious naval ships by adding a multi-mission armament that can engage a wide array of targets with precise and rapid attacks.

The primary objectives of this capstone project were to analyze the following concepts:

- Does the increased range and firing rate of the EMRG provide an operational advantage over current ship-board weapon systems?
- Will the increased magazine depth of the EMRG provide an operational advantage over current ship-board weapon systems?
- What are the most important characteristics of the EMRG for improving the operational performance of the ATF in the amphibious assault mission?

Team Longshot explored these questions by creating a force on force simulation of an amphibious assault based on the operational concept shown in Figure 1.

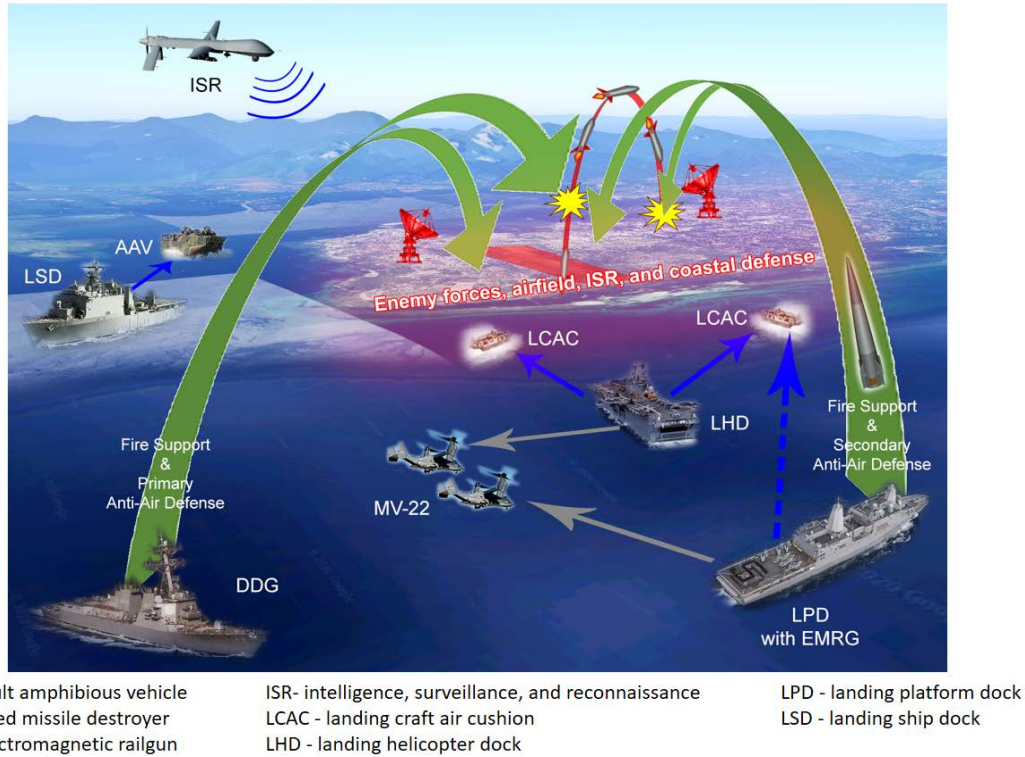

Figure 1. Operational Concept Using an EMRG

The measures of effectiveness and performance of the ATF were based on the probability of regaining control of the objective area (defined as the sufficient incapacitation of enemy targets to allow for friendly control of the objective area), percentage of intercepted enemy missiles, and survivability of the ATF. Joint Publication 3-02 was the guiding document used to create a sequence of events for the simulated mission. Five courses of action (COAs) were simulated to demonstrate the possible force structures available to naval commanders, including one COA without an integrated EMRG (COA 1 requires an escort destroyer) and four conceptual COAs that utilize the EMRG in various ways. Table 1 lists the simulated COAs along with a short description and reasoning. The five COAs vary in ATF configuration to explore the performance of the EMRG in achieving the objective focus areas by calculating the results based on the effectiveness and performance measures when conducting the amphibious assault mission.

Table 1. Simulation Amphibious Task Force Loadouts

Course of Action	Ship 1	Ship 2	Ship 3	Ship 4	Colloquialism	Description
1	LPD	LSD	LHD	DDG	Conceptual EABO	Planned capability, no EMRG, DDG provides NSFS and AA-W
2	LPD-E ¹	LSD	LHD	DDG	Game Changer	EMRG added to LPD to assist in NSFS and AA-W
3	LPD-E	LSD	LHD	N/A	No Escort	DDG removed, EMRG provides all NSFS and AA-W
4	LPD	LSD	LHD	LPD-E-C2	Command and Control (C2)	EMRG C2 flagship coordinates mission and provides all NSFS and AA-W
5	LPD-E	LSD	LHD	LPD-E-C2	C2-E2 ²	All ATF LPDs equipped with EMRG. Secondary LPD-E assists with NSFS and AA-W

¹ LPD ship equipped with EMRG

² One command and control (C2) ship and two EMRG equipped ships (E2)

Three levels of enemy force strength were designed (low, medium, high) to produce a spectrum of ATF performance outcomes for each COA. Results from COA 3 were the most repeatable and reliable results based on regression analysis; therefore, COA3 was further explored and analyzed in more detail. Table 2 shows a side-by-side comparison of the COA1 and COA3 simulation results in relation to the measures of effectiveness, supporting the potential performance benefits of an EMRG.

Table 2. Results for Measures of Effectiveness

	Medium Enemy Concentration			High Enemy Concentration		
	Control of Objective Area (%)	Enemy Missiles Defeated (%)	ATF Survivability (%)	Control of Objective Area (%)	Enemy Missiles Defeated (%)	ATF Survivability (%)
COA1	0%	46.82%	3.21%	0%	33.60%	0%
COA3	98.06%	89.94%	95.72%	82.16%	83.60%	75.19%

Analysis of the simulation results showed that cycle time, various probabilities of hit, number of EMRGs, firing scheme, and initial ATF standoff distance are the most significant factors that influence the performance of the EMRG against medium and high enemy concentrations in the objective area. The addition of the EMRG improved the performance and survivability of the ATF when conducting the amphibious assault mission. The capstone team recommends continued development and integration of the technology targeting, cooling, power generation, and autoloading subsystems to extend the significant EMRG characteristics beyond what was simulated in this study.

References

O'Rourke, Ronald. 2019. *Navy Lasers, Railgun, and Gun-Launched Guided Projectile: Background and Issues for Congress*. CRS Report No. R44175. Washington, DC: Congressional Research Service.
<https://crsreports.congress.gov/product/details?prodcode=R44175>.

ACKNOWLEDGMENTS

The members of Team Longshot would first like to thank our significant others, friends, and family members for their patience and understanding. Your encouragement and support in our educational endeavors made this possible. The staff of the Naval Postgraduate School Systems Engineering Department provided us with the tools and experience needed to lay the foundation of this systems engineering project. Special thanks to Abby McConnell and the entire staff at the NPS Graduate Writing Center and Thesis Processing Office for reviewing and editing this report. Lastly, the entire team would like to extend many thanks and appreciation to our NPS capstone advisors, Dr. Eugene Paulo, Dr. Wayne Porter, and Dr. Paul Beery. Your experience, advice, and simulation assistance were invaluable in the completion of this capstone report.

THIS PAGE INTENTIONALLY LEFT BLANK

I. INTRODUCTION

A. BACKGROUND

Amphibious assaults are sea-launched military attacks that involve a combination of ships, military expeditionary unit (MEU) land forces, and aerial systems within the littorals. This collective force, the amphibious task force (ATF), can include a variety of ships and escort systems, but the most prominently included ships are landing helicopter assault (LHA), landing ship dock (LSD), or landing platform dock (LPD) ships (U.S. Navy n.d.). This group also usually consists of a fire support asset, like the Arleigh Burke class guided missile destroyer (DDG). The DDG provides fire support primarily with missiles and short-range five-inch guns that can reach thirteen to twenty nautical miles. The amphibious ships within the ATF utilize a limited number of on-board weapons and aerial systems to defend against threats, while also confronting the opposing force with assault capabilities to transport land forces to the adversary's shore. This complex task can be challenging for even the most competently trained, organized, and equipped force.

While conducting littoral operations in a contested environment (LOCE), an amphibious assault on an enemy's shore or territory poses a significant challenge due to the numerous and well-supported opposing faction's naval, aerial, missile, and land forces (Department of the Navy [DON] 2017). The fighting and defense from the opposing force's land base grants them an inherent advantage against ATF assault missions. The ATF does not benefit from similar infrastructural and logistical advantages, because the operational environment requires the force to be detached and self-sufficient. Naval and joint force planners have proposed a range of modern solutions that would change how the ATF is equipped and structured. The future of successful LOCE may depend largely on the warfighting capability and capacity of the expeditionary advanced base operations (EABO) (DON 2017). Weapon modernization holds tremendous potential in increasing the warfighting capabilities of amphibious ships that engage in LOCE by providing long range over-the-horizon strikes from expeditionary bases. One of the most promising energy-based weapons developed by the Navy is the electromagnetic railgun (EMRG) which has

been projected to be able to provide sustained long-range attacks approximately 100 nm away at a rate of fire of ten rounds per minute (O'Rourke 2019).

B. RELATED RESEARCH

A literary search and discovery process revealed some of the future naval complications and adversities that will require new approaches or systems to overcome potential threats. Team Longshot gathered publicly available information on enemy capabilities, force planning, current capabilities, and weapons research to gain a more holistic view of the challenges and the evolving naval environment.

1. A2 / AD

The arrangement of global and regional sensing networks and both long-range and coastal defense missile systems have increased adversaries' defensive capabilities against amphibious operations. This capability pairing is known as anti-access/area denial (A2/AD) and it is becoming more widely adopted by defense departments across the world (U.S. Marine Corps 2017). This manual explains that the overall concept of an A2/AD strategy relies on gathering information through intelligence, surveillance, and reconnaissance (ISR) systems to pinpoint targets for guided surface-to-air missiles (SAM) and surface-to-surface missiles (SSM). It goes on to state that this effectively establishes exclusion zones in which naval operations are severely limited, due to the threat of incoming enemy missile salvos. In addition, sea mines, unmanned aerial vehicles (UAVs), and long-range missiles can even further extend the range and lethality of enemy A2/AD. Lastly, the manual notes that the A2/AD strategy serves as an effective deterrent against amphibious operations by establishing a blockade that constrains amphibious ship movements to distances outside an operationally effective range from the shore. This reduces the amphibious ships' operational availability to supply MEU land forces with supplies or to provide naval surface fire support (NSFS) (U.S. Marine Corps 2017).

2. EABO

In conjunction with the LOCE concept, the U.S. Navy and Marine Corps are in the process of developing the concept of EABO (Berger 2019). This conceptual operation

schema will give Marines the ability to conduct mobile and distributed operations to provide fires, ISR with targeting, electronic warfare, and ground support in a contested environment (Clark and Walton 2019). The expeditionary advanced bases (EABs) can be sea-based command ships or forward operating bases on shore or inland. To set up an EAB within a contested environment, some form of external fire support is needed as the bases are being established, since their capabilities will be limited and vulnerable during base establishment. The EABs will also need to have a sufficient defensive capability to withstand the fires that could be employed against them. The EABs will be crucial in the development of the EAB operational concepts for amphibious operations and the utilization of current and future weapon technologies may influence future naval and joint operation force planning.

3. CURRENT NAVAL WEAPON SYSTEMS

The current naval fleet has shifted from large guns to missiles when needing to provide long-range NSFS; this transition to increase accuracy and lethality came with its own trade-offs, including higher costs and decreased magazine depths for NSFS missions. In addition to missiles, Arleigh Burke class destroyers also have five-inch guns that allow them to fire from up to 13 nautical miles away at 16–20 rounds per minute (U.S. Navy n.d.). The missile capabilities of Arleigh Burke destroyer can reach approximately 700 nm for long-range surface attacks using Tomahawk land attack missiles (TLAM). The high cost and limited storage capacity for the TLAM have driven the U.S. Navy to seek new artillery solutions. The U.S. Navy installed the advanced gun system (AGS) on a few destroyers, but due to the artillery round having to be specially designed for the AGS, the cost per round was extremely high (~\$800k) compared to other guns (Duplessis 2018). A technological solution to provide long-range NSFS is needed to retain the U.S. Navy's overmatch capabilities.

4. DEVELOPMENTAL WEAPONS

Currently, the weapons aboard standard amphibious ships range from close-in weapon systems (CIWS) to expensive missiles that have effective ranges of less than 50 nm. Naval and joint operations have been investigating the technology and scientific

principles of an EMRG since 2005 as a promising materiel solution that can launch low-cost GPS aided projectiles at great distances and speed (O'Rourke 2019). The electromagnetic propulsion requires tremendous amounts of electrical energy to generate enough magnetic force to propel the center armature carrying the projectile, as seen in Figure 1. Power generation in this new device can vary, and several weapon development physicist and systems engineers within the U.S. Navy have explored various energy ratings. The most common 32 and 64 MJ concept devices are the primary contenders for future weapons development and integration onto naval ships in the future. Power levels translate into multiple weapon characteristics including weapon range, firing cycle rates, and projectile velocity. In the last decade, the Navy has overseen the construction of two EMRG prototypes and their successful ground testing (O'Rourke 2019). The EMRG is expected to provide a multi-mission aerial defense and NSFS capability by the 2030 timeline.

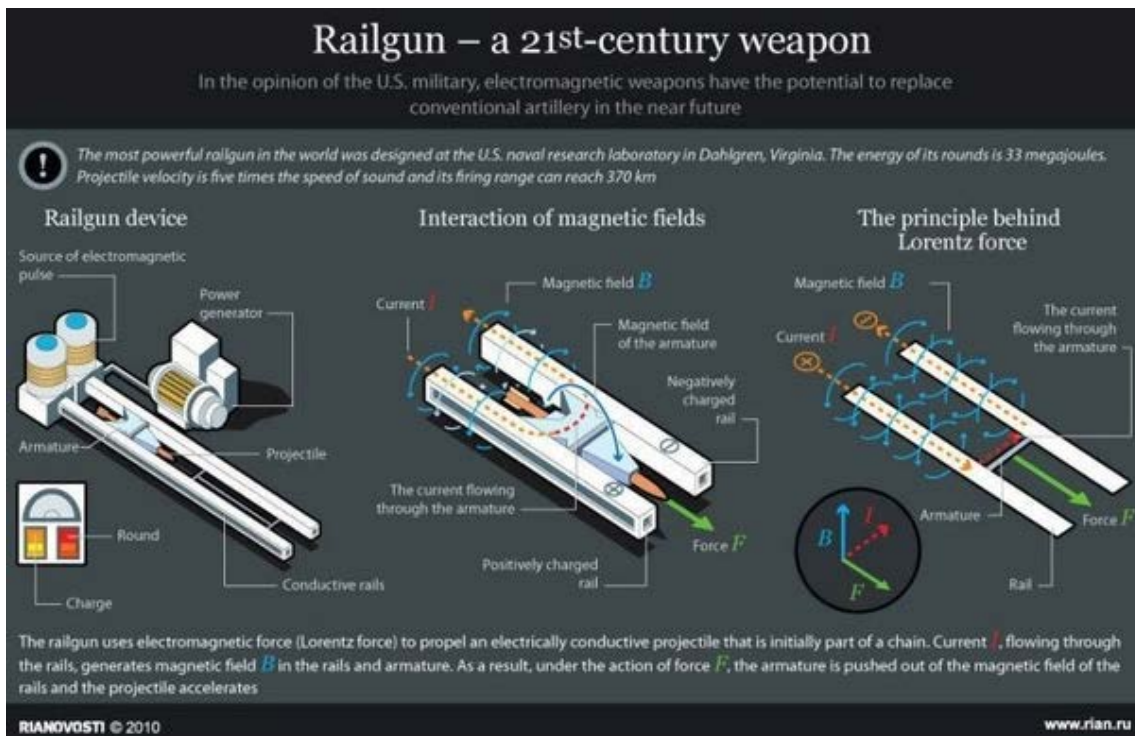

Figure 1. Core EMRG Components and Science. Source: Bennett (2016).

C. PROBLEM STATEMENT

Amphibious ships must maneuver within close proximity of the shore to support landing force operations, which puts them within range of enemy counterattacks. While most amphibious ships have CIWS and limited missiles for providing a defensive capability to the ATF, these systems are ill-equipped to provide the required sustained long-range NSFS or substantial defense against near-peer aerial or surface attacks. Currently, force planning requires that one or more surface action group ships like the Arleigh Burke-class destroyer be added for NSFS and long-range anti-air defense during amphibious operations (Joint Chiefs of Staff 2019). This reliance on escort ships exposes the long-range capability gap of amphibious ships like the LPD and LSD class amphibious ships. The insufficient self-reliance reduces ship survivability in defensive engagements and lethality in offensive attacks. The elimination of the most susceptible target can be catastrophic to the entire ATF and the mission. The limited storage of high explosive guided missiles is another limiting factor that presents the issue of premature ammunition runout. In a highly contested environment, the numerous targets and redundant firing procedures can quickly expend available stockpiles of ammunition. The inability to resupply vertical launch system (VLS) cells at sea forces individual ships to disengage from the scenario, causing significant weakening of the remaining ATF.

In addition, auto-loading capability, space capacity, and weight allocation of missiles are a few contributing factors that limit the number of missiles allowed upon an LPD ship, and the perilous cargo of highly explosive missiles that the amphibious ships carry to each destination should be considered. Given these factors, an accurate strike on the ship could result in an unforeseen chain of events that would render the ship inoperable, and this susceptibility reduces the overall survivability of ships carrying large stockpiles of highly explosive missiles. The capstone team has acknowledged these capability gaps and has devised a systems engineering approach to analyze how the EMRG weapon system is more operationally effective than conventional missile weapons in an amphibious assault mission.

D. SYSTEMS ENGINEERING PROCESS

The focus of this project centers on an amphibious assault on an enemy's shore and as such, Team Longshot tailored the engineering process to closely follow the principles of mission engineering where the overall mission objectives drive the design process. The Systems Engineering Body of Knowledge describes mission engineering as a subset of systems engineering that emphasizes an individual mission as the system of interest which drives all system development activities (Giachetti 2020). In this method, all of the design, planning, and integration activities of the individual system capabilities will be directly related to the overall performance the mission. A recent article highlighted the use of Model-Based Systems Engineering (MBSE) concepts as a modern approach to the mission engineering process that could be applied to architecting and design of a system in relation to the overall mission (Beery and Paulo 2019). In order to formally merge mission engineering and MBSE into a systems engineering process, Team Longshot decided on a tailored Vee model, as seen in Figure 2. In this context, the left side of the Vee was modified to include systems engineering process elements that are centered on the development of a "mission system" (to include both operational and system modeling) which addresses the potential capability that an EMRG-equipped LPD may add to the execution of that mission.

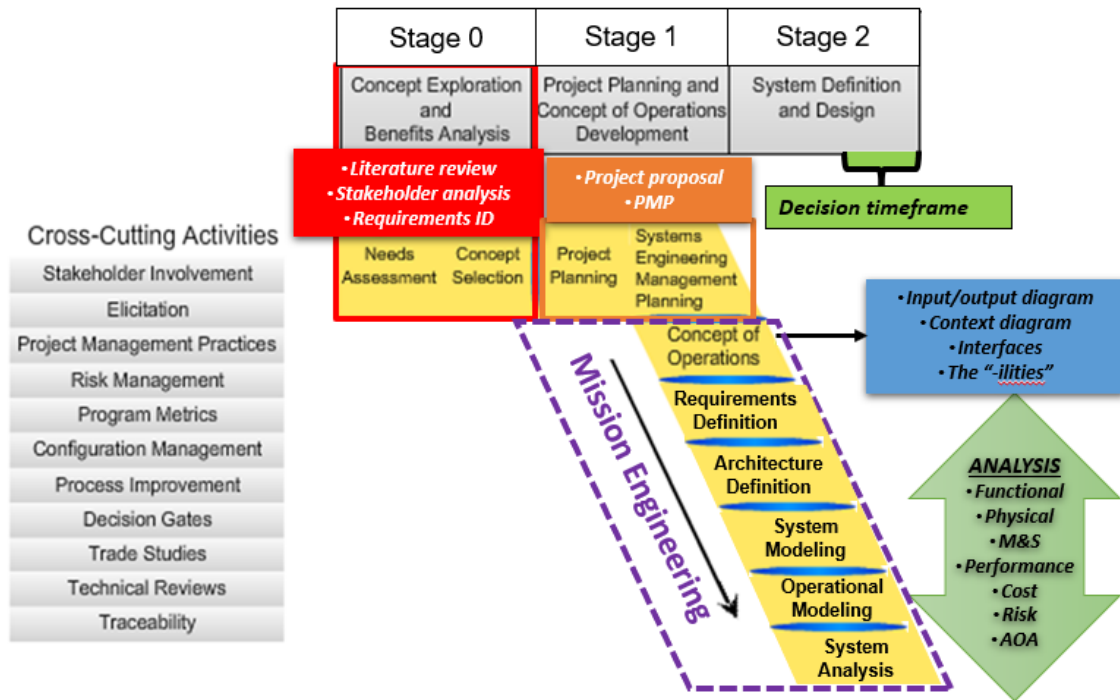

Figure 2. Systems Engineering Method, Modified Vee
Adapted from Beery and Paulo (2019).

The portions of the Vee utilized were broken into three distinct stages: Systems Engineering Stage 0, Stage 1 and Stage 2. Systems Engineering Stage 0 explored the concept of a naval EMRG aboard an LPD class ship and evaluated the potential operational effectiveness benefits. Important activities in this stage included: the literature review, stakeholder analysis, a needs assessment, and requirements identification. Systems Engineering Stage 1 further defined the project plans with the delivery of the project proposal and the project management plan (PMP). The main activities in Stage 1 included project planning, the creation of a management strategy that set the pace for the bulk of the project, and the tail end of Stage 1 also included the start of mission engineering. Systems Engineering Stage 2 continued mission engineering throughout its entirety, which consisted of the following: defining a concept of operations for the EMRG, further developing the needs identified in Stage 0 into an authoritative set of requirements, and then translating those into a system architecture. Lastly, modeling and simulation of

various EMRG and Amphibious Task Force (ATF) configurations were conducted, and the results were analyzed in order to support a decision and recommendation for a solution that offers the most beneficial operational effectiveness.

E. RESEARCH OBJECTIVES

Team Longshot sought to model and evaluate the operational benefits and mission effectiveness of an EMRG-equipped LPD ship while it performs an amphibious assault. The long-range capability of an EMRG was investigated for use in landing site preparation support, deep-strike NSFS to expeditionary land forces, and anti-air defense. The EMRG has the potential to engage and eliminate enemy targets from a much greater distance than traditional artillery pieces offering the potential benefit of increased ship survivability. Multiple configurations of the EMRG and ATF composition were compared and analyzed to determine the benefit (if any) of using an EMRG-equipped LPD San Antonio class ship.

Table 1 shows an overview of the capability gaps of the current LPD amphibious ship and the corresponding potential improvements an EMRG could provide in successfully executing EABO. The primary objective of the EMRG study and simulation is to determine if there is an improvement in the operational effectiveness of a ship that utilizes EMRG weapons in support of expeditionary fighting forces, and to quantify the potential areas of effectiveness an EMRG could provide in defensive and offensive capabilities during expeditionary campaigns.

Table 1. LPD Capability Gaps and EMRG Benefits and Projected Results

LPD¹ Capability Gap	EMRG² Benefit	Potential Result
Most shipboard weapons range < 30 nm	Increased range	<ul style="list-style-type: none"> • Improved assault distance • Improved NSFS³ effectiveness • Improved LPD-17 survivability
Limited missile magazine and reload capability	Increased magazine depth	<ul style="list-style-type: none"> • Improved lethality • Increased dwell time for NSFS
Long range firing rate	Decreased response time	<ul style="list-style-type: none"> • Improved NSFS effectiveness
Expensive guided missiles	Lower cost projectiles	<ul style="list-style-type: none"> • Improved cost exchange ratio

LPD¹ Capability Gap	EMRG² Benefit	Potential Result
Storage of reactive munitions decrease survivability	No propellant storage requirement	<ul style="list-style-type: none"> • Improved LPD-17 survivability • Decreased logistical requirements
Reliance on high explosive projectiles	Kinetic energy kill	<ul style="list-style-type: none"> • Decreased munition cost • LPD-17 survivability improvement

¹LPD – landing platform dock

²EMRG – electromagnetic railgun

³NSFS – naval surface fire support

F. INTRODUCTION SUMMARY

This system concept study project analyzes the potential benefits and improvements in operational effectiveness in ATF missions that support EABO by integrating an EMRG on an LPD San Antonio class ship. In Section B, the capstone team reviewed relevant documentation including force planning, enemy capabilities, technology, and developmental weapons reports to identify a focused opportunity area where the long-range energy-based EMRG could be paired with existing naval ships to create improved operational envelopes. This current armament loadout of amphibious ships requires the addition of external escort ships from the carrier strike group which highlights the capability gap of sustainable long-range fire support in Section C. Team Longshot modified a system engineering process to focus on the amphibious assault mission as a way to investigate the potential benefits of the EMRG. The structured mission engineering approach was adopted to create a list of system study objectives that would be researched in later chapters. Chapter II begins the research into the addition of an EMRG to amphibious ships by ascertaining the stakeholder needs, establishing system functions, and mapping operational functions to establish an operational concept Chapters III and IV build upon the operational concept by creating system models that will interact in a simulation of the ATF assault mission to produce measurable results. The results will be used to evaluate the EMRG effectiveness in the constructed ATF simulation that supports EABO.

THIS PAGE INTENTIONALLY LEFT BLANK

II. CAPABILITIES ANALYSIS

A. STAKEHOLDER ANALYSIS

In order to evaluate the EMRG as a potential naval weapon, it was essential to perform a stakeholder analysis to establish a prioritized list of needs from the organizations that may have a vested interest in an EMRG-equipped LPD San Antonio class ship. The complex task of integrating and using a technologically advanced EMRG weapon system involves many stakeholders. The majority of the analysis and stakeholder identification for this project came from a comprehensive review of openly available publications related to expeditionary force organization, amphibious operations, distributed lethality (DL), littoral operations in a contested environment, and the current state of ship capabilities. Next, a stakeholder prioritization ranking was established to address any overlap or potentially conflicting needs and desires among the stakeholders, and a scale from one to three was assigned to determine the priority of the stakeholder with one being the highest and three being the lowest.

The majority of the stakeholders' needs were centered on the EMRG capability, including how it could be integrated and utilized as an improvement to long-range attack, and its defensive capabilities when performing expeditionary and amphibious operations. The highest priority stakeholders include the expeditionary forces at the Naval Expeditionary Combat Command (NECC) and the EMRG developers at Office of Naval Research (ONR) because of their direct influence on the key requirements as end users and system designers. This research could also be used to assist the top stakeholders at NECC and ONR by justifying future investment into EMRG technology and implementation. The second priority group includes joint development groups within the United States Army and the broader groups of EMRG operators and maintainers (O&M). While it is beneficial that the needs and goals of these groups be considered, they should not override or detract from the needs of the primary stakeholders for this project. The last priority group includes stakeholders that have limited influence over the core principles and requirements imposed on the acquisition and implementation of the EMRG in EABO. The needs and goals from priority group three are important to consider but must not supplant the needs and goals of

priority groups one and two. Table 2 provides a summary of the needs, goals, and areas of concern for each stakeholder.

Table 2. Stakeholder Analysis Matrix

Stakeholder	Priority	Needs & Wants	Goal	Concerns
Navy Expeditionary Combat Command	1	Utilize long range attack and defense EMRG capabilities aboard LPD ships	Succeed in completing amphibious missions Minimize force loss and risk	Enemy force and weapon capabilities Disruption of established naval practices
Office of Naval Research – Railgun Development	1	Integration of the EMRG on LPD ships Mature the EMRG technology	Fill weapon capability gaps in naval expeditionary operations	Auto-load capability Size, power generation, and cooling for EMRG
U.S. Army – CCDC Armaments Center	2	Leverage EMRG technology in the development of future weapon platforms	Joint collaboration with the Navy in developing and fielding EMRGs	Divergent priorities Integration and commonality barriers
EMRG operators	2	Operational training and manuals Targeting and launch interface Troubleshooting procedures	Effectively operate the EMRG to complete EABO	Ease of use Safety and launch protocols
EMRG maintainers	2	Maintenance training and manuals Reduced need for special tools Consideration for human factors	Maintain EMRG system to maximize operational availability	Component seaworthiness Task frequency Spare part availability & reliability
Defense Industrial Base	3	Specific government development, integration, and testing requirements	Provide a capable weapon that can be integrated aboard naval ships to increase company profits	Shifting and unrealistic requirements Allocated ship weight and size for system
Shipwrights	3	Implementation strategy to incorporate EMRG Fully developed EMRG and subsystems delivered	Build and overhaul LPD ships to include EMRG and associated subsystems	Allocated ship weight and size for system Interferences when overhauling legacy LPDs
Allied Nations	3	Show of force from expeditionary forces Foreign military sales	Support from U.S. Navy in defending their nation	Vulnerability of remote naval areas and territories
Congress	3	Detailed EMRG acquisition strategy Periodic progress updates	Fill current capability gaps in a cost-effective acquisition program	Budget and schedule overruns

Important integration and operational sustainment considerations from stakeholder groups one and two were considered early in the acquisition phase; however, the primary stakeholders hold operational performance and force capability as a higher need. Consequently, the focus of this project will center on the functional capabilities of the

EMRG as a long-range offensive and defensive asset in an EABO. The interoperability with joint services and integration tasks of shipbuilders and original equipment manufacturers will be omitted due to the priority of primary stakeholders. For this project, it is assumed that interoperability and integration of the EMRG are achieved by the 2030 timeframe.

B. FUNCTIONAL ANALYSIS

The scope of this project examines and analyzes the added defensive and offensive multi-mission capabilities that an EMRG could provide when integrated onto an LPD ship and employed during EABO. The team conducted an initial functional analysis in order to determine how the EMRG will operate within the context of a mission scenario course of action (COA) and to narrow the focus of the project to functions that directly affect and relate to employment of the EMRG. The broad functional decomposition of the EABO mission is shown in Figure 3.

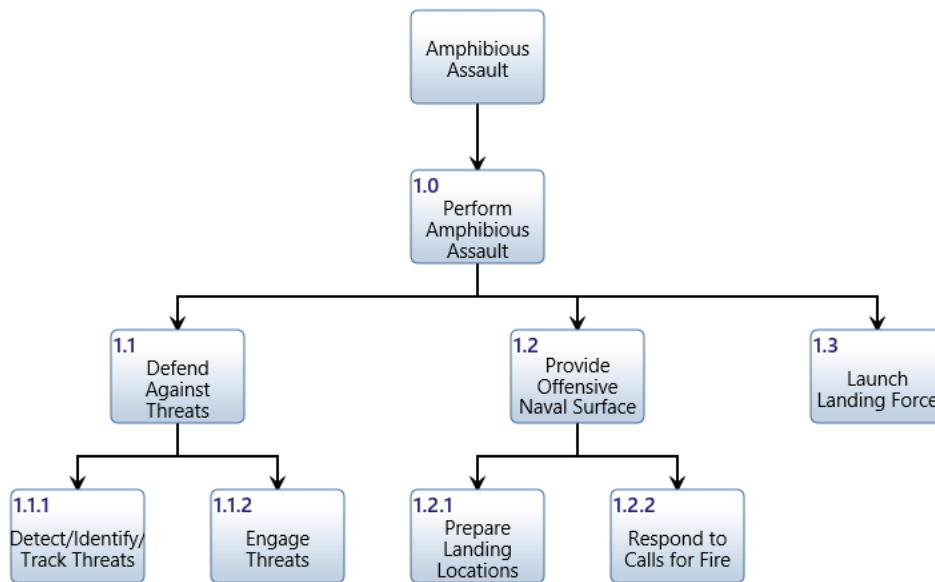

Figure 3. Functional Hierarchy of EABO Mission

The following provides additional details for these functions that Team Longshot has identified based on stakeholder requirements:

1.0 Perform EABO Mission: This function represents the high-level process whereby the collective ATF executes the EABO mission.

1.1 Defend Against Threats: This function represents the process whereby the EMRG integrated on an LPD class ship is employed to defend against enemy aerial threats to the ATF.

1.1.1 Detect/Identify/Track Threats: This function represents the process whereby enemy aerial threats are detected, positively identified, and targeted using onboard and remote ISR systems.

1.1.2 Engage Threats: This function represents the process whereby the EMRG is fired using the information gathered in function 1.1.1 to engage and defeat enemy aerial threats.

1.2 Provide Offensive Naval Surface Fire Support: This function represents the process whereby the EMRG integrated on an LPD class ship is employed to provide fire support against enemy surface vessels and on-shore threats and facilities.

1.2.1 Execute Scheduled Fire Support: This function represents the process whereby the EMRG integrated on an LPD class ship is employed to execute a coordinated fire support plan against strategic enemy locations in order to facilitate the first wave landing force assault, as well as subsequent waves.

1.2.2 Respond to Calls for Fire: This function represents the process whereby the EMRG integrated on an LPD class ship is employed to respond to calls for fire received from landing forces approaching shore or already on shore. The calls for fire provide more specific targeting coordinates in response to the enemy's tactics against the allied assault.

1.3 Launch Landing Force: This function represents the process whereby the landing force, including infantry and armored vehicles, disembark head to shore, and conduct an amphibious assault on the enemy.

The functional hierarchy shown in Figure 3 is representative of the Navy's vision for EABO; however, the functions themselves are not significantly different from those that comprise current amphibious assault operations. The discerning factors of interest and focus points for this project are:

1) How the functions are performed specifically with an EMRG integrated on an LPD San Antonio class ship, and,

2) How the employment of an EMRG affects other aspects of the system context, such as the ATF composition and ship standoff distances.

Table 3 lists the Measures of Effectiveness (MOEs) and Measures of Performance (MOPs) that will be used to quantify these factors and the operational effectiveness of the EMRG, as well as their function traceability. Likewise, Figure 4 identifies these MOEs as major outputs of the mission system of interest.

Table 3. Measures of Effectiveness (MOEs) and Measures of Performance (MOPs)

Measures of Effectiveness	Measures of Performance	Function Traceability
Control of Objective Area (%)	Total number of targets destroyed (excluding missiles)	1.1 Defend Against Threats 1.2 Provide Offensive Naval Fire Support 1.3 Launch Landing Force
Enemy Missiles Defeated (%)	Accuracy of DDG Weapons (Missiles Destroyed to Missiles Engaged)	1.1 Defend Against Threats
	Accuracy of EMRG (Missiles Destroyed to Missiles Engaged)	
ATF Survivability (%)	Number of ATF ships remaining	1.1 Defend Against Threats

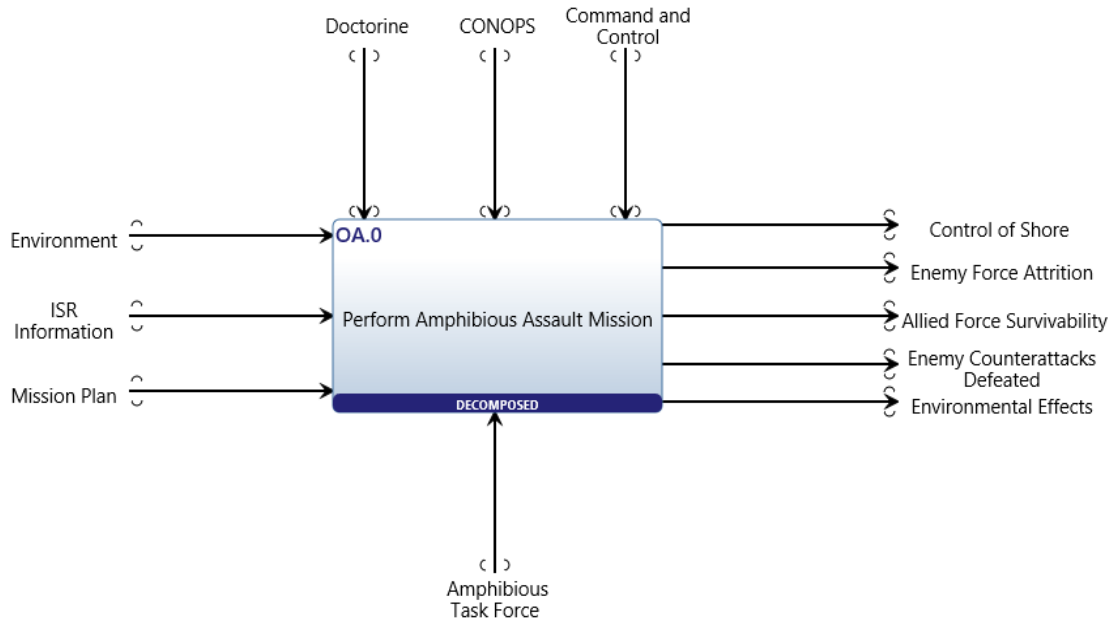

Figure 4. System Input-Output Diagram

C. OPERATIONAL ANALYSIS

This report evaluates the operational effectiveness of an ATF when conducting an amphibious assault. The design of the scenario will utilize the concept of EABO and establishment of EABs both offshore and/or on shore, as shown in Figure 5. Operationally, an LPD is not likely to conduct amphibious assault missions alone and would likely have other amphibious ships with it from an ATF, such as the LHA, LHD, LCS, or LSD (Joint Chiefs of Staff 2019). The ATF will also require sufficient defensive fire support, particularly for anti-air warfare (AA-W). This defensive support will likely come from at least one surface action group (SAG) ship, which would also provide additional NSFS. For the scenario concept of operations (CONOPS), Team Longshot modeled one Arleigh Burke class DDG detached from its SAG to support the amphibious ships.

In addition, a number of assumptions and constraints were created to help establish a context boundary for the ATF when conducting the amphibious assault mission. For example, a large-scale invasion into a theater of operations would involve many naval, land, and air systems but this individual mission CONOPS does not consider systems that provide the same force strength with or without the EMRG. Likewise, mine countermeasures (MCM) performed by the LCS were not included in the model since it had no bearing on the performance and operational benefits of the EMRG weapon. The ATF composed of a DDG, amphibious ship, and the landing force (LF), and amphibious and aerial transportation vehicles will be the focus throughout the project for determining success of the amphibious assault mission. Anti-submarine, mine countermeasures, and anti-ship operations will not be considered, as the threat of these attacks occurs outside the scope of the amphibious assault. The ATF will break off from the nearby offshore EAB to conduct the amphibious assault mission. The regionally positioning of the EAB greatly reduces the response and travel time of the ATF. The LCS will travel with the ATF as an escort to assist with clearing the mines for establishing the boat lanes required for the landing craft air cushions (LCACs) and assault amphibious vehicles (AAVs) to traverse from ship to shore, but as noted above, the LCS is not modeled. The approach lanes are assumed to be clear from mines but may still be hindered by opposing forces or system failures.

After the EAB has been established, the ATF will need to defend itself against numerous enemy threats, including anti-ship cruise missiles, medium- range ballistic missiles, drones and drone swarms, small boats, small-arms fire, aircraft, and ground artillery (stationary and mobile). It is believed the DDG will be able to handle most of the longer-range air threats, though any leakers that get past it will have to be intercepted by the amphibious ships. The ATF will also need to provide naval surface fire against critical targets, such as enemy ISR systems, airfields, and coastal defense units. Attacking these targets will be critical to the success of the overall amphibious assault mission and gaining control of the operational area. The goal of the ATF is to successfully deploy the LF with minimal loss. It is critical to the mission that these boats and the vertical lift platforms can reach the shore multiple times without being destroyed by the enemy's established littoral and land denial capabilities.

Likewise, in order to meet the previously stated mission objectives, the ATF will be equipped with weapons systems able to engage the enemy forces at various distances. The DDG provides long-range fire support using Tomahawk missiles for NSFS. This limited, long-range capability makes it difficult for the DDG to provide landing site preparation attacks and sustained surface fire support after landing forces arrive ashore. A majority of the DDGs VLS cells are loaded with short to medium-range missiles for air defense of the amphibious ships (Clark, Commanding the Seas, The U.S. Navy and the Future of Surface Warfare 2017). The primary function of the DDG for this mission will be to provide a majority of the air defense for the escorted amphibious ships. It is believed that the integration of the EMRG capability on the LPD San Antonio class ship will allow sustained and high operational-tempo fire support at targets that are positioned over the horizon. This added capability will also allow for the LPD to have a larger range of potential stand-off distances from the enemy, helping to decrease its vulnerability to shore fires.

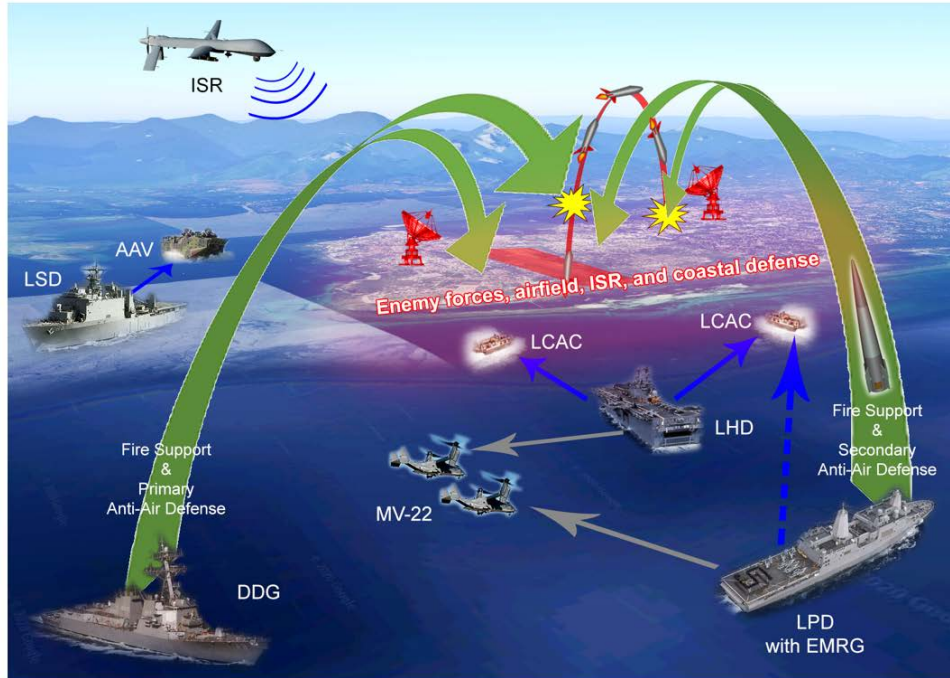

AAV - assault amphibious vehicle
 DDG - guided missile destroyer
 EMRG - electromagnetic railgun

ISR- intelligence, surveillance, and reconnaissance
 LCAC - landing craft air cushion
 LHD - landing helicopter dock

LPD - landing platform dock
 LSD - landing ship dock

Figure 5. High-Level Operational Concept of an ATF Assault Launched from an EAB

THIS PAGE INTENTIONALLY LEFT BLANK

III. MODELING AND SIMULATION

A. INTRODUCTION

A model of the EMRG and the ATF was created with the inputs listed below to test the performance and effectiveness in an amphibious assault mission; the design of the model and course of action for amphibious assault utilized the concepts of EABO, LOCE, and the Marine Corps functional concept for marine air ground task force (MAGTF) fires. It also utilized the joint publication documents of amphibious operations (JP 3-02) and joint forcible entry operations (JP 3-18 Ch1) for the planning and sequencing of events that were simulated for the amphibious assault mission. The assumptions, inputs, and COAs were important factors in creating a discrete event simulation in the commercial simulation software package ExtendSim 10. Team Longshot's hypothesis is that the addition of an EMRG to an LPD San Antonio class ship may provide greater defense of the ATF with its long-range and quick-firing rates against incoming threats. The shipboard EMRG may also enhance assault capabilities with landing site preparation with over the horizon attacks and NSFS during the landing and infantry engagements ashore.

As outlined in the operational concept from Chapter II, an enemy force has seized control of a partner nation's remote island shoreline. In addition, the enemy force has established control of the surrounding air, sea, and land environments with various ISR, cruise missile, aerial, ground vehicle, and infantry assets. Next, a contingent of amphibious ships with escorts breaks off from a regionally positioned EAB to form an ATF with the clear purpose of conducting an amphibious assault on the captured shoreline to regain control. Then, after the formation of the ATF and departure from the EAB, the ATF conducts a three-phase amphibious assault mission, as shown in Figure 6. The following graphics were created by Team Longshot in the web-based MBSE tool Innoslate as a representation of each ship's role during the large-scale assault mission.

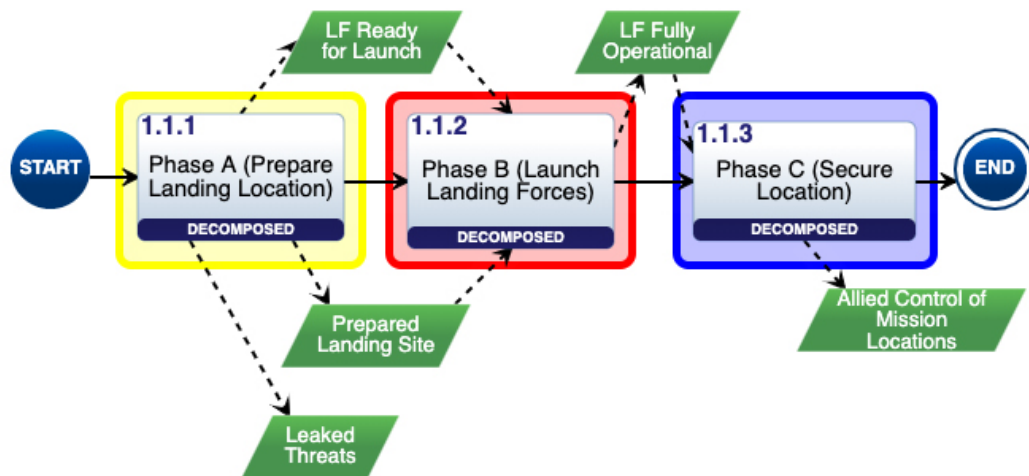

Figure 6. Amphibious Assault Mission Phases

Phase A is the initial phase of the mission and includes landing site preparation and commencing transit to the transport area at a designated distance from shore. Phase B continues the ATF movement to the Transport Area and Landing Craft, Air cushion launch area (CLA), as well as the line of departure (LOD) for AAVs. This is in accordance with the sea areas defined in JP 3-02 and is shown in Figure 7. The role for the ATF ships during phase B centers on the deployment and protection of the LF.

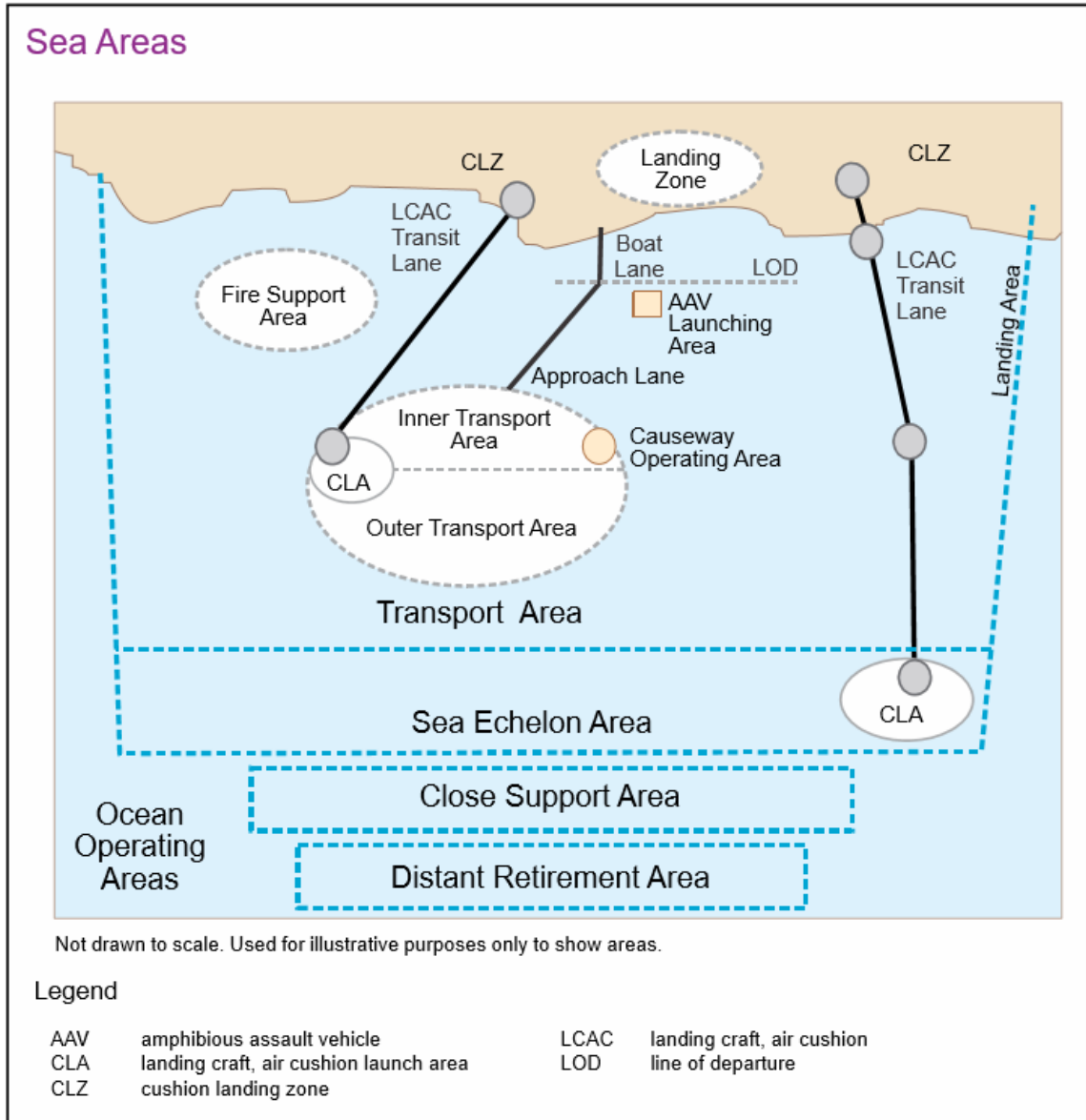

Figure 7. Sea Areas (JP3-02)

Phase C follows the actions of the LF after they assemble on the shore and retake control of the island with continued support from the ATF ships. The simulation ends when enough of the enemy force has reduced to manageable levels to signify that strategic locations have been secured by the landing force.

Figures 9–11 in Section C illustrate the relationships between the ships that occur during the assault, including various high-level activities and functional flows. This

architecture sequence was then recreated and modeled in ExtendSim to build the simulation Team Longshot used to produce results based on the amphibious assault mission. Color-coded boxes are used to link the functional flow block diagram (Figure 6) with the sections of the simulation (Figures 9–11) to help distinguish between the individual phases of the mission. Appendix A shows the ExtendSim images with the color-coded portions.

B. ASSUMPTIONS AND CONSTRAINTS

A list of assumptions and constraints was developed to focus the scope of the simulation and what could be considered external, as the number of systems, interactions, and reactions involved in an amphibious assault can vary when considering a large-scale operation. To reiterate the focus of this capstone report, simulation efforts were designed to emphasize the operational effectiveness of the EMRG in performing offensive and defensive actions. Many external systems and associated inputs that were not included in the model could influence the COA. Some of those systems and inputs include additional allied naval forces, allied long-range missile capabilities, enemy naval forces, hydrographic and meteorological considerations, civilian involvement, surrounding tactical landscapes, and geopolitical environments. The context diagram in Figure 8 uses grayed-out boxes to show an overview of what was considered external to the modeling and simulation efforts.

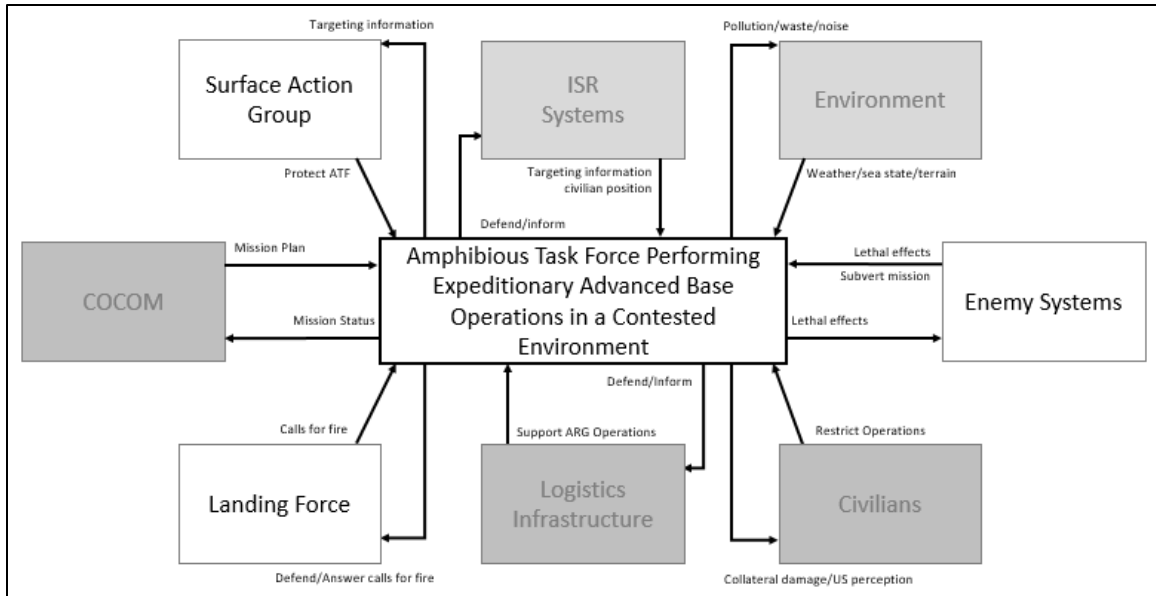

Figure 8. Modeling and Simulation Context Chart

Team Longshot considered these abstract influences of lower impact to the operational performance of a weapon system, so a number of assumptions and constraints were applied to the modeling and simulation efforts for this analysis of the EMRG. Table 4 documents major factors that Team Longshot analyzed and addressed as assumptions that would bound the modeling and simulation efforts:

Table 4. Simulation Assumptions

Assumption	Description	Reason
DDG dedicated to AA-W	DDG will provide a majority of the long-range missile defense. The LPD-E will handle remaining missile defense.	Current amphibious ships are not capable to providing sufficient AA-W defense.
No resupply	Logistics and resupply of ATF were not included	ATF ships are operating remotely from the EAB and allied docks
ATF ships answer calls for fire	ATF aircraft and LF ground-based systems do not to answer calls for fire	Calls for fire directed only to the ATF ships are simulated
Variable EMRG ranges	EMRG can vary energy levels to fire projectiles between the minimum and maximum range	Targets will vary in distance from the EMRG
EMRG multi-target capability	EMRG can swap between air or surface targets with a time delay	EMRG will be capable of switching between various target types
EMRG auto loads projectiles	EMRG has an auto load capability based on projectile capacity	The time delay to reload will vary stochastically to

Assumption	Description	Reason
		account for variation in reloads
EMRG retargeting time delay	Retargeting process incurs a stochastic time delay in firing projectiles	This accounts for target acquisition and EMRG turret movements
EMRG immune to environmental conditions	Environmental conditions and sea-state will not affect accuracy of the EMRG	Advanced targeting computer and compensation accounts for sea-state
Independent EMRG power consumption	The power required to fire the EMRG is independent of the previously installed power plants used to transport the ship.	Integration of the EMRG will have its own power generation and storage subsystems
No EMRG maintenance during mission	The EMRG is highly reliable and will not need maintenance during the assault mission	The weapon system has been thoroughly tested and improved
LPD and LHD launch distance	The LPD and LHD launches LF via LCACs from 15 nm off-shore	LCACs require a 15 nm from shore launch distance
LSD launch distance	The LSD launches LF via AAVs from 2 nm off-shore and then moves to approximately 20 nm off-shore	AAVs require a 2 nm from shore launch distance
MV-22 troop transport	MV-22 Ospreys are used to carry additional LF from all three of the amphibious ships	Aerial transports will be utilized to deploy landing forces
ISR Availability	ISR will not be interrupted for the duration of the mission	ISR is considered external to the ATF
Prioritized target list generated prior to mission	A list of priority targets was generated before the start of the mission using stealth ISR systems	Advanced planning would uncover the enemy locations
Anti-ship engagements, Anti-submarine countermeasures, and Mine countermeasures	Enemy forces external to those on or near the enemy shoreline (including air, sea, and land systems) were not encountered by the ATF.	Mine countermeasures, anti-ship engagements, and anti-submarine countermeasures are provided by naval forces external to the ATF. This may be considered to include external allied forces including the SAG, LCS escorting the ATF, or other friendly ships

To follow the flow of events established with the Phase architecture from Figure 6, operational requirements such as the launch distance of LCACs and AAVs, utilization of MV-22 Ospreys for troop transport, and reliance on ATF ships for calls for fire were added to the assumption list. Additionally, EMRG assumptions were necessary to build the model of a weapon that is still being developed. Currently, the performance characteristics, system

features, numerical values are unknown, which required a number of EMRG focused assumptions. The external context boundaries, operational limitations, and EMRG constraints made the modeling and simulation efforts possible by regulating the inputs to include only the most influential factors. Chapter V, Section B, reexamines a number of these assumptions that could be added to increase the level of realism in future studies.

C. COURSE OF ACTION DEFINITION

Establishing a generalized COA definition required a sequencing of events, including maneuvering ships, defense against incoming threats, deployment of land forces to secure objectives ashore, and protection of the land forces through calls for fire. To assist with the modeling and simulation of this COA the team has utilized MBSE to graphically express the progression of the mission using the Innoslate web-based software. The series of events begins with the initial decision to execute the mission and leads into the following three phases: Phase A – Landing Site Preparation, Phase B - Launch Landing Forces, and Phase C – LF Secures Location.

Phase A of the mission includes the initialization of ATF travel to the Area of Operations from the EAB starting point, the transport of the LF and pre-positioning of designated amphibious ships, the protection of the ATF by the DDG or EMRG equipped LPD (LPD-E), and the amphibious objective area (AOA) preparation by the DDG Tomahawk missiles or GPS assisted EMRG projectiles. Figure 9 shows the individual sequences for each ship in Phase A, and shows loops that illustrate how the DDG is modeled to intercept aerial and missile threats coming towards the ATF. In this manner, the DDG acts as a defensive umbrella for the ships as they transit to the Area of Operations and Transport Area. When the LPD-E replaces the current model LPD, the EMRG will be modeled to perform similar protection and site preparation loops. The transparent yellow grouping box corresponds to the higher-level phase sequence shown in Figure 6 and in the ExtendSim source diagrams in Appendix A.

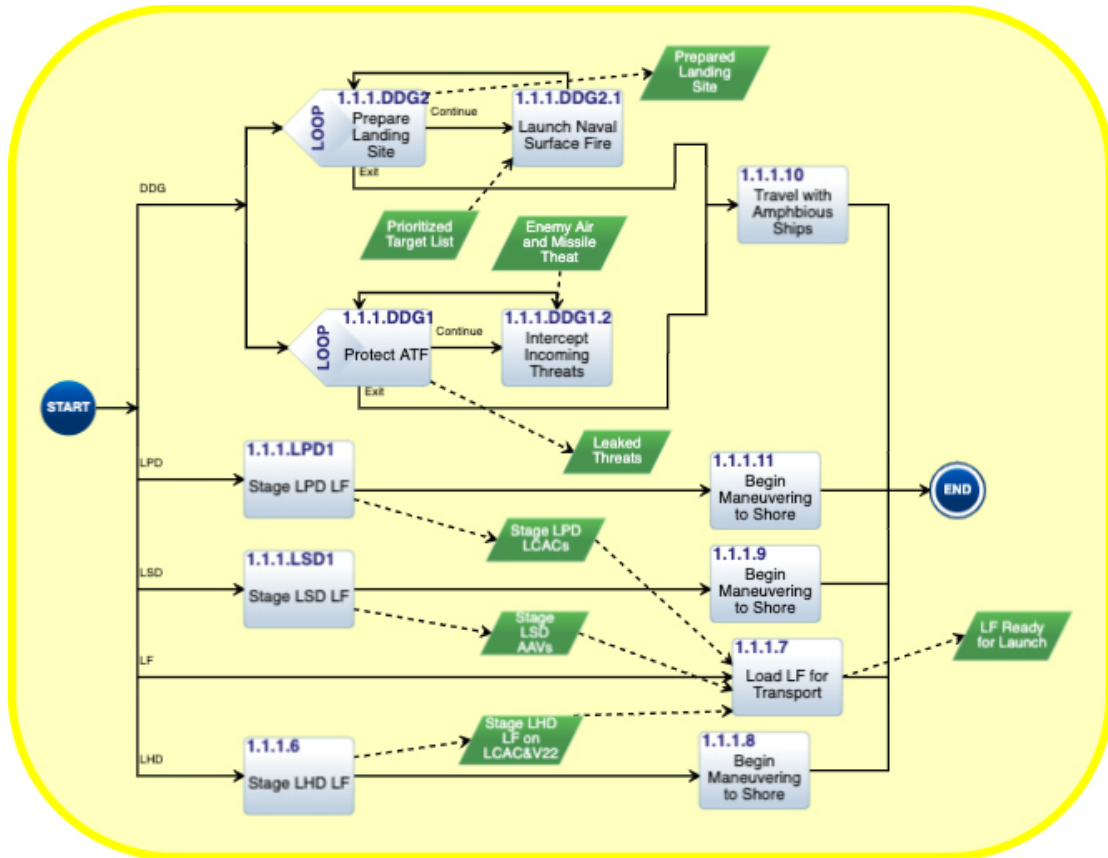

Figure 9. Phase A—Prepare Landing Location

At the start of Phase B, the ATF ships continue traveling to the Transit Area, the CLA, and the LOD, to launch the first wave of landing forces aboard LCACs and AAVs. Notably, an input characteristic for this phase is the preparation of the AOA from Phase A, and the staging of the landing force for rapid deployment to LZ and landing craft/air cushion landing zone (CLZ). In relation, Figure 10 shows that the DDG continues to provide AA-W and NSFS throughout Phase B using its remaining stockpile of missile munitions. As shown, the LHD and LPD (as well as the LPD-E in future COAs) position for LCAC launches approximately 15 nm off-shore, although the ships patrol the area with some variation in distance (staying within 20 to 25 nm) to allow for multiple LCAC and V-22 transportation cycles. Next, the LSD performs a button-hook maneuver to launch the AAV from the 2 nm LOD location before withdrawing back to the ATF location approximately 15 to 20 nm off-shore. After landing, the LF will begin to conduct its mission of reclaiming the shoreline and surrounding areas, which will conclude Phase B

and lead to the final phase of the amphibious assault. The transparent red grouping box corresponds to the higher-level phase sequence shown in Figure 6 and in the ExtendSim source diagrams in Appendix A.

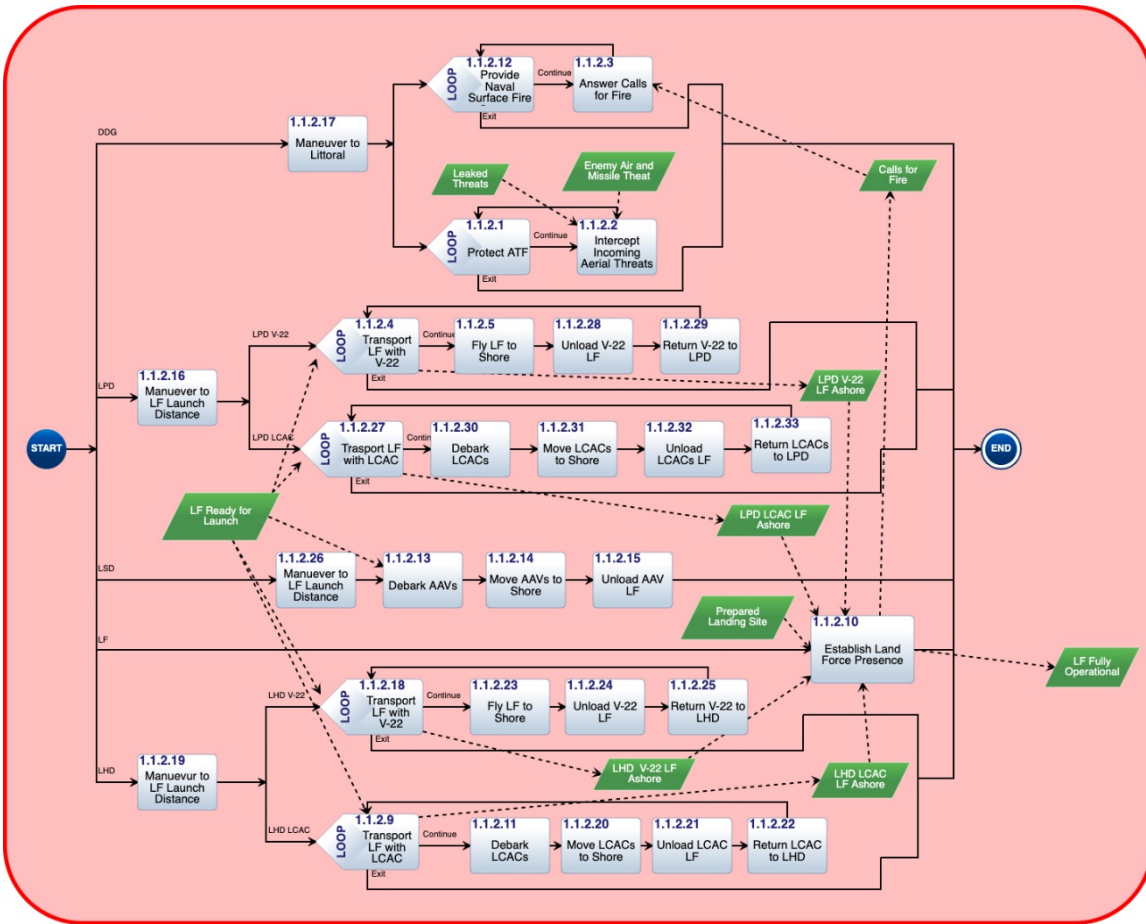

Figure 10. Phase B—Launch Landing Forces

Once a majority of the LF has reached the shore, Phase C commences as the infantry and ground vehicles begin to establish control of the AOA including the airfield, the port, communication towers, civilian centers, and various other locations. Figure 11 shows the sequential functional flow of activities in Phase C. In this phase, an EAB is eventually established ashore that can coordinate land, sea, and air operations to regain control of the island. The simulation of the skirmishes ends after the ATF has secured control of the AOA. The EAB that has been established is in position to support Phase IV (stability) and

phase V (enable civil authority) operations in the AO. The transparent blue grouping box corresponds to the higher-level phase sequence shown in Figure 6 and in the ExtendSim source diagrams in Appendix A.

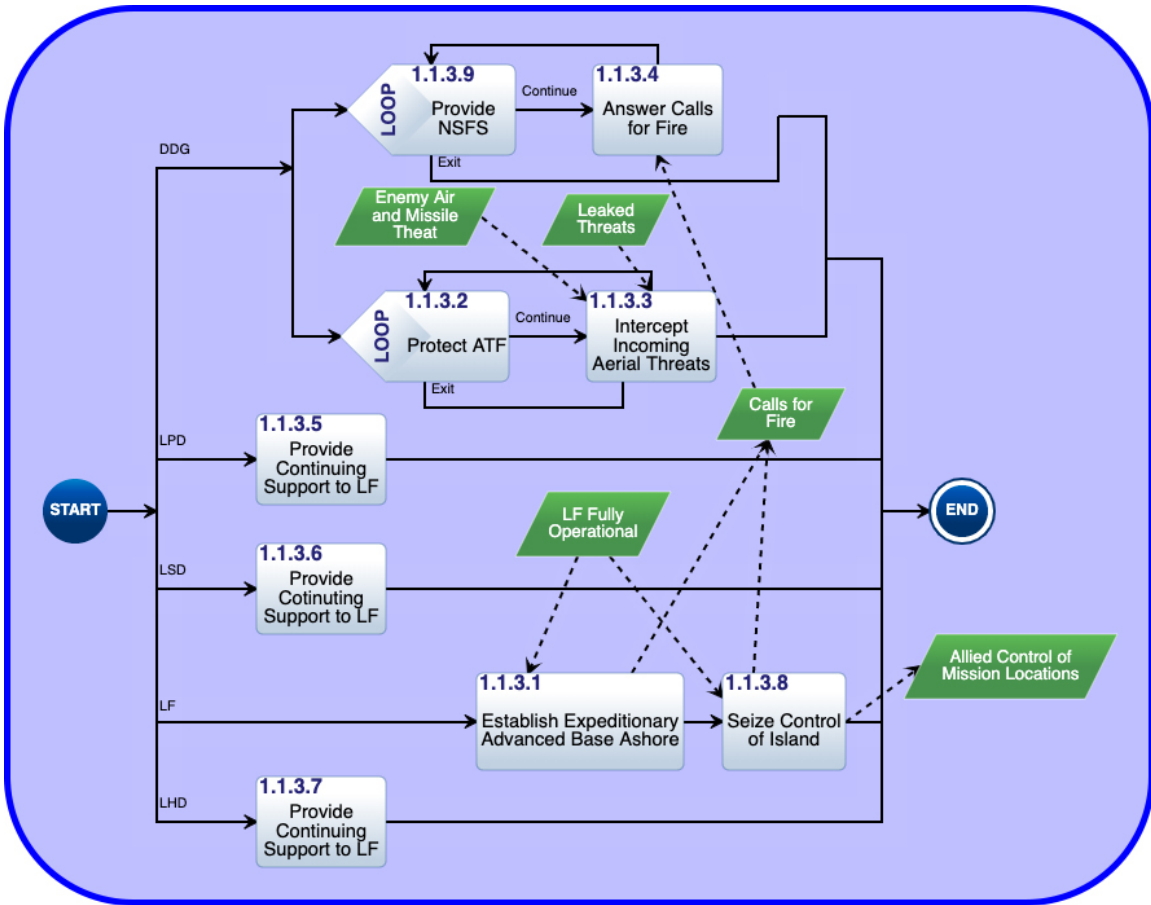

Figure 11. Phase C—Landing Force Secures Location

D. SIMULATION INPUTS

Building the simulation in ExtendSim 10 from the phase architectures required the creation of inputs and data tables that would be manipulated in the discrete model with queues and calculations. Input values for existing weapon systems, amphibious ships, and the escort DDG were gathered from public sources and were then input into their respective property tables. Table 5 lists the grouped input values and ranges used to create the simulation; minimum and maximum values indicate a range of possible values for each run

of the simulation. In turn, the values that contain the same minimum and maximum values are fixed values that were gathered from available research or have no bearing on the performance of the EMRG. Since the EMRG is still in the technology maturation and development phase, ranges and values were assumed or determined based on literary research of the weapon’s technical documents. Inputs that had quantifiable units were maintained while immeasurable percentages and large-scale counts of troop transports were left without simulated units. Table 5 shows the grouped properties that were used in the simulation to create the EABO assault mission.

Table 5. ATF Model and Simulation Inputs

EMRG Properties			
Variable	Min	Max	Units
Cycle Time	3	6	sec
Retargeting Delay	3	5	sec
Range	15	100	nm
Velocity	5.8	7.3	Mach
P-hit for Moving Aircraft	0.4	0.9	-
P-hit for Stationary Ground Targets	0.4	0.98	-
P-hit for Mobile Ground Targets	0.4	0.9	-
P-hit for Incoming Missiles	0.4	0.8	-
Missile Engagement Range	2	22	-
TLAM Properties			
Variable	Min	Max	Units
Velocity	0.62	0.62	Mach
Range	869.3	869.3	nm
P-hit for Stationary Ground Targets	0.98	0.98	-
P-hit for Mobile Ground Targets	0.95	0.95	-
Quantity	30	30	-
ESSM Properties			
Variable	Min	Max	Units
Velocity	4	4	Mach
Range	2	40	nm
P-hit for Moving Aircraft	0.95	0.95	-
P-hit for Incoming Missiles	0.95	0.95	-
Quantity	264	264	-

ATF Properties			
Variable	Min	Max	Units
ATF Initial Standoff Distance	60	80	nm
LCAC / MV-22 Deployment Distance	15	15	nm
Number of LCACs Deployed			
From LPD	2	2	-
From LHD	3	3	-
Number of LCAC Trips			
From LPD	8	8	-
From LHD	9	9	-
Number of MV-22s Deployed			
From LPD	2	2	-
From LHD	6	6	-
From LSD	2	2	-
Number of MV-22 Trips			
From LPD	21	21	-
From LHD	70	70	-
From LSD	4	4	-
AAV Deployment Distance	2	2	nm
Number of AAVs Deployed	15	15	-
Probability of Sink			
LPD	0.1	0.1	-
LHD	0.1	0.1	-
LSD	0.1	0.1	-
DDG	0.1	0.1	-
DDG Support Distance	10	10	nm
Number of DDG VLS Cells	96	96	-
VLS Cycle Time	2	2	sec
VLS Retargeting Delay	10	15	sec
Landing Force Properties			
Variable	Min	Max	Units
Force per LCAC	75	75	-
Force per MV-22	25	25	-
Force per AAV	25	25	-

After creating the inputs for the ATF, the simulation required enemy forces to be added that would oppose the ATF transportation. The enemy forces that established a base of operations on the partner nation's island are listed in Table 6 and include mobile and stationary targets on the ground or in the air. Each of the enemy forces includes

corresponding input factors such as missile velocities, attrition rates, and equipped armaments, which were entered into the simulation using data tables. The last column indicates the number of EMRG hits required to completely disable or destroy the target. The simulation accounts for kinetic energy weapon’s lethality compared to current high explosive missiles used by naval forces and the difference in the area of effect was accounted for with target hit points when engaged by the EMRG. The approach to quantifying the number of enemy forces stationed at the enemy location required an assumption that split the simulation into three enemy strength concentrations that increased in intensity to stress blue force in the simulation. This approach sought to account for situations where enemy presence is unknown or obscured from advanced ISR mapping. Table 6 shows the low, medium, and high concentrations of each of the enemy force categories, and include enemy force inputs used to counteract the ATF amphibious assault.

Table 6. Enemy Strength Parameters

Name	Description	Low Concentration	Medium Concentration	High Concentration	Hit Points per Target
Air Installations	Airfield, hangars, parked aircraft	12	18	24	3
Air Mobile Targets	Airborne aircraft	12	30	48	1
Ground Stationary	Radar/comms sites, parked vehicles, bunkers, other structures	100	150	200	2
Ground Mobile	Vehicles in motion	25	75	125	2
Anti-Air Defense Sites	Anti-aircraft missile launch sites and platforms	10	15	20	3
Coastal Defense Sites	Coastal missile launch sites and platforms	10	15	20	4

Name	Description	Low Concentration	Medium Concentration	High Concentration	Hit Points per Target
Hardened Missile Sites	Missile launch sites and platforms that can only be engaged by blue force infantry, not long-range projectiles	5	10	15	2
Objective Targets	Targets that must be destroyed in order to secure the final objective (i.e., airfield)	12	24	36	2

E. ATF COMPOSITIONS AND SIMULATION VARIATIONS

The planned EABO simulation represented by the phase diagrams illustrates an example of an amphibious assault with existing capabilities. Simulation results from the initial runs of the assault mission established a data point that was used to compare the amphibious assault mission results with and without an EMRG installed on the LPD. The LPD-E would perform the same functions as a standard LPD but would have the added long-range capability to engage air and surface targets. Four additional COAs were created to test various ATF configurations with the EMRG weapon system employed. Table 7 shows an overview of the COAs that altered the ship combinations used in each ship selection of the ATF. A more detailed description of the five COAs and the reason for the variation is included below in the COA sub-sections.

Table 7. Simulation Amphibious Task Force Loadouts

Course of Action	Ship 1	Ship 2	Ship 3	Ship 4	Colloquialism	Description
1	LPD	LSD	LHD	DDG	Conceptual EABO	Planned capability, no EMRG, DDG provides NSFS and AA-W

Course of Action	Ship 1	Ship 2	Ship 3	Ship 4	Colloquialism	Description
2	LPD-E ¹	LSD	LHD	DDG	Game Changer	EMRG added to LPD to assist in NSFS and AA-W
3	LPD-E	LSD	LHD	N/A	No Escort	DDG removed, EMRG provides all NSFS and AA-W
4	LPD	LSD	LHD	LPD-E-C2	Command and Control (C2)	EMRG C2 flagship coordinates mission and provides all NSFS and AA-W
5	LPD-E	LSD	LHD	LPD-E-C2	C2-E2 ²	All ATF LPDs equipped with EMRG. Secondary LPD-E assists with NSFS and AA-W

¹ LPD ship equipped with EMRG

² One command and control (C2) ship and two EMRG equipped ships (E2)

1. COURSE OF ACTION 1—CONCEPTUAL EABO

As previously described, the initial COA includes three amphibious ships (LPD, LSD, and LHD) with a DDG escort capable of providing all of the long-range NSFS and AA-W. This COA would be the ATF composition if an amphibious assault was required before an EMRG could be retrofitted to an LPD ship, and it creates a comparison point for the remaining four COAs. This comparison point is intended to show the difference in ATF performance and effectiveness during the amphibious assault without an EMRG and situations that include an EMRG.

2. COURSE OF ACTION 2—GAME CHANGER

COA 2 replaces the LPD with the EMRG-equipped LPD-E to provide additional offensive and defensive capabilities. Summarily, the new LPD-E in COA 2 adds the Protect ATF and Provide NSFS action loops in the sequence of events as simultaneous functions. Realistically, the ship would not fire when deploying LCACs or MV-22s and the timing of the simulation was modeled to avoid this. Figure 12 shows how the LPD-E performs multi-role operations to launch landing forces via LCACs and MV-22s while providing AA-W protection and NSFS for initial calls for fire from the landing force in Phase B.

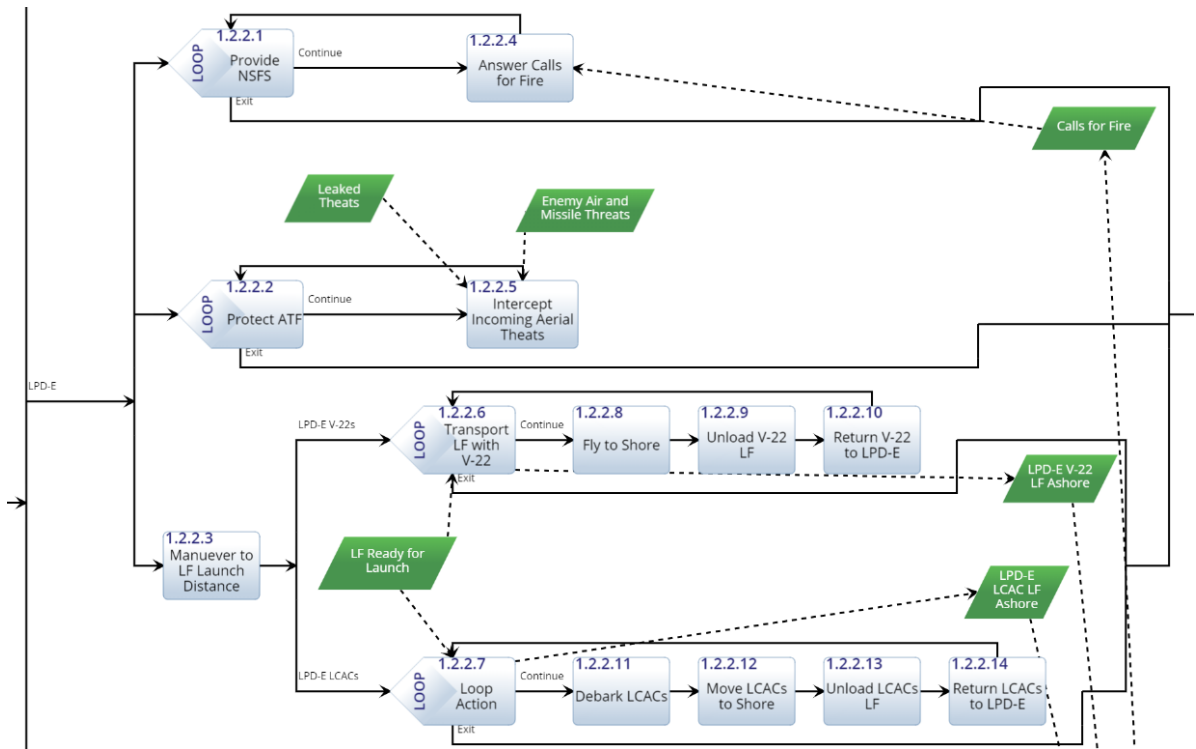

Figure 12. LPD-E Operational Sequence in Phase B

3. COURSE OF ACTION 3—NO ESCORT

COA 3 builds upon the merits of the LPD-E by removing the DDG as an escort ship from the simulation. The elimination of the former primary defensive umbrella and attack ship tests the capacity of the EMRG as a primary defensive and offensive weapon system in the absence of conventional VLS missiles. This COA was built to assess whether the EMRG can be a force multiplier that would overcome the need for SAG destroyer or cruiser escort ships.

4. COURSE OF ACTION 4—COMMAND AND CONTROL

The composition, usage, and load out of the LPD take a drastically different role in COA 4, to include command and control functionality. The ship configuration and sequence mimic the first COA ATF configuration, with the exception that the DDG is replaced with an LPD-E-C2. The LPD-E-C2 is a multi-functional ship that can perform long-range NSFS, defensive AA-W, and serve as the ATF flagship to maintain command

and control center of operations for the amphibious assault. This amphibious command ship becomes a mobile expeditionary base of operations with weapons capable of defending the ATF and attacking critical land-based priority targets.

5. COURSE OF ACTION 5—C2-E2

In COA 5, the LPD-E-C2 replaces the DDG as the primary ship in both surface fires support and air threat defense roles. A secondary LPD-E is also utilized because this COA assumes that most LPD ships have been retrofitted with an EMRG. The remaining two amphibious ships remain the same. The intention of this COA and ATF composition is to examine the effects of two EMRG capable ships.

6. MISSION PLANNING SUMMARY

The five COAs provide a unique mix of different ATF arrangements with varying levels of EMRG capable ships and DDG presence or absence. The primary and secondary roles of AA-W defense and NSFS offense switch between the planned COAs. By creating five COAs, the comparisons Team Longshot intended to focus on the EMRG and its potential effectiveness in completing the amphibious assault mission and are summarized in Table 8.

Table 8. Comparison Points between Simulated COAs

COA Comparisons	Description
2 to 1	Effect of integrating an EMRG on an LPD while still performing traditional LPD role
3 to 2	Effect of no DDG surface/air support, multirole LPD-E
4 to 1	Effect of LPD-E as C2 and supplanting DDG as surface/air support role
5 to 4	Effect of “all LPD retrofit with EMRG”

THIS PAGE INTENTIONALLY LEFT BLANK

IV. RESULTS

A. DESIGN OF EXPERIMENTS

A design of experiments (DOE) was created in order to determine the relationships between the input factors that affect the functionality of the EMRG, and the outputs that directly relate to the MOEs. Table 9 lists the input factors that were varied, as well as their associated value ranges. Table 10 lists the responses, or MOPs, that were observed, as well as their traceability to the MOEs. It should be noted that the MOEs are ranked in order of importance: 1) Control of the Objective Area, 2) Enemy Missiles Defeated, and 3) ATF Survivability. Consequently, the “# Targets Destroyed” response and associated regression models are considered to be the most important, as “Control of the Objective Area” is defined as the sufficient incapacitation of enemy targets to allow for friendly control of the objective area. Additionally, the total number of enemy missiles fired varied from run to run, so the observed responses of enemy missiles fired and enemy missiles destroyed were used to normalize the results into a percentage of missiles destroyed, which also corresponds to the MOE.

Table 9. DOE Input Factors

EMRG Properties ¹				
Factor	Min	Max	Units	ExtendSim Label
Cycle Time ⁵	3	6	sec	EMRG_Cyc_Time
Velocity ⁶	5	8	Mach	EMRG_Velocity
P-hit for Moving Aircraft	0.4	0.9	-	EMRG_Phhit_AirMob
P-hit for Stationary Ground Targets	0.4	0.98	-	EMRG_Phhit_GroSta
P-hit for Mobile Ground Targets	0.4	0.9	-	EMRG_Phhit_GroMob
P-hit for Incoming Missiles	0.4	0.8	-	EMRG_Phhit_Missile
# EMRGs per LPD-E ²	1	2	-	Qty_LPDE_EMRG
# EMRGs per LPD-E-C2 ³	1	2	-	Qty_LPDE_C2EMRG
Firing Scheme ⁴	1	2	-	Number_Fired
ATF Properties				
Factor	Min	Max	Units	ExtendSim Label
ATF Initial Standoff Distance	60	80	nm	Start_Dist
DDG / LPD-E-C2 Support Distance	10	10	nm	Support_Dist

¹ Applies only to COA2, COA3, COA4, and COA5

² Applies only to COA2, COA3, and COA5

³ Applies only to COA4 and COA5

⁴ Value of “1” translates to “shoot-look” firing scheme; value of “2” translates to “shoot-shoot-look”

⁵ Four-level discrete factor

⁶ Two-level discrete factor

Table 10. DOE Observed Responses

Responses (Measure of Performance)	Measure of Effectiveness
Total Number of Enemy Targets Destroyed	Control of Objective Area (%)
Total Number of Enemy Missiles Destroyed	Enemy Missiles Defeated (%)
Total Number of Enemy Missiles Fired	
Total Number of ATF Ships Sunk	ATF Survivability (%)

Using the selected input factors listed in Table 9, a 512-point space-filling DOE matrix was constructed using the nearly orthogonal nearly balanced (NOB) Mixed Design Worksheet (Vieira 2012). The worksheet allowed the matrix to be created using both continuous and discrete values, facilitating an analysis approach for exploring alternative

system configurations per (MacCalman, Beery and Paulo 2016). JMP Pro was used to perform a multivariate analysis of the input factors to look at the correlation, which returned a maximum value of 0.0337. This indicated that there was minimal correlation between input variables and that the DOE matrix was acceptable.

The same DOE matrix was used for each of the five COAs; however, not all input factors were applicable across the COAs. For example, COA1 does not include an EMRG as part of the ATF, so none of the EMRG properties were incorporated into the DOE matrix. Additionally, each COA was run at low, medium, and high enemy concentrations, as defined in Table 6 in Chapter III. This resulted in a total of 15 DOE simulation runs.

Table 11 shows the mean values for the observed responses, and Figures 13–15 show graphical representations of these values for the purpose of visualizing the differences. Observations indicate that 1) COA1 does poorly at all levels of enemy concentrations; 2) the addition of an EMRG in COA2 through COA4, and two EMRGs in COA5, shows an increase in effectiveness against all responses; 3) COA3 is the most effective against missiles; and 4) COA5 is the most effective at destroying targets.

Table 11. Mean Values for Observed Responses

	Low Enemy Concentration			Medium Enemy Concentration			High Enemy Concentration		
	# Targets Destroyed (221 max)	% Missiles Destroyed	# ATF Ships Sunk	# Targets Destroyed (409 max)	% Missiles Destroyed	# ATF Ships Sunk	# Targets Destroyed (593 max)	% Missiles Destroyed	# ATF Ships Sunk
COA1	39.26	23.49%	0.85	39.26	26.22%	3.77	51.04	20.90%	4.00
COA2	212.26	29.78%	0.74	336.67	32.96%	2.39	395.50	30.58%	3.65
COA3	220.38	78.91%	0.05	339.83	70.67%	0.80	357.60	51.37%	2.37
COA4	213.16	35.44%	0.56	311.74	34.22%	2.56	341.94	30.95%	3.82
COA5	220.44	41.96%	0.35	378.20	45.14%	1.58	477.60	46.55%	2.86

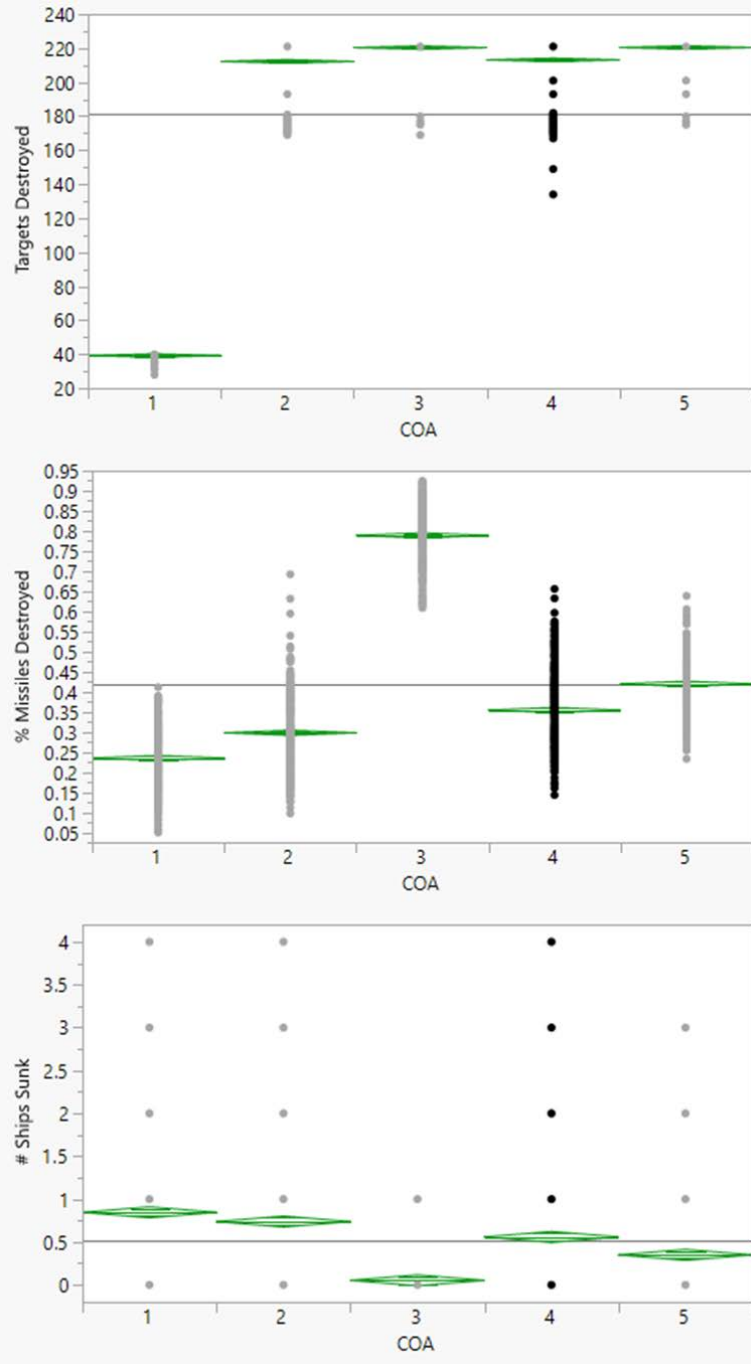

Figure 13. Mean Values for Observed Responses at Low Enemy Concentration

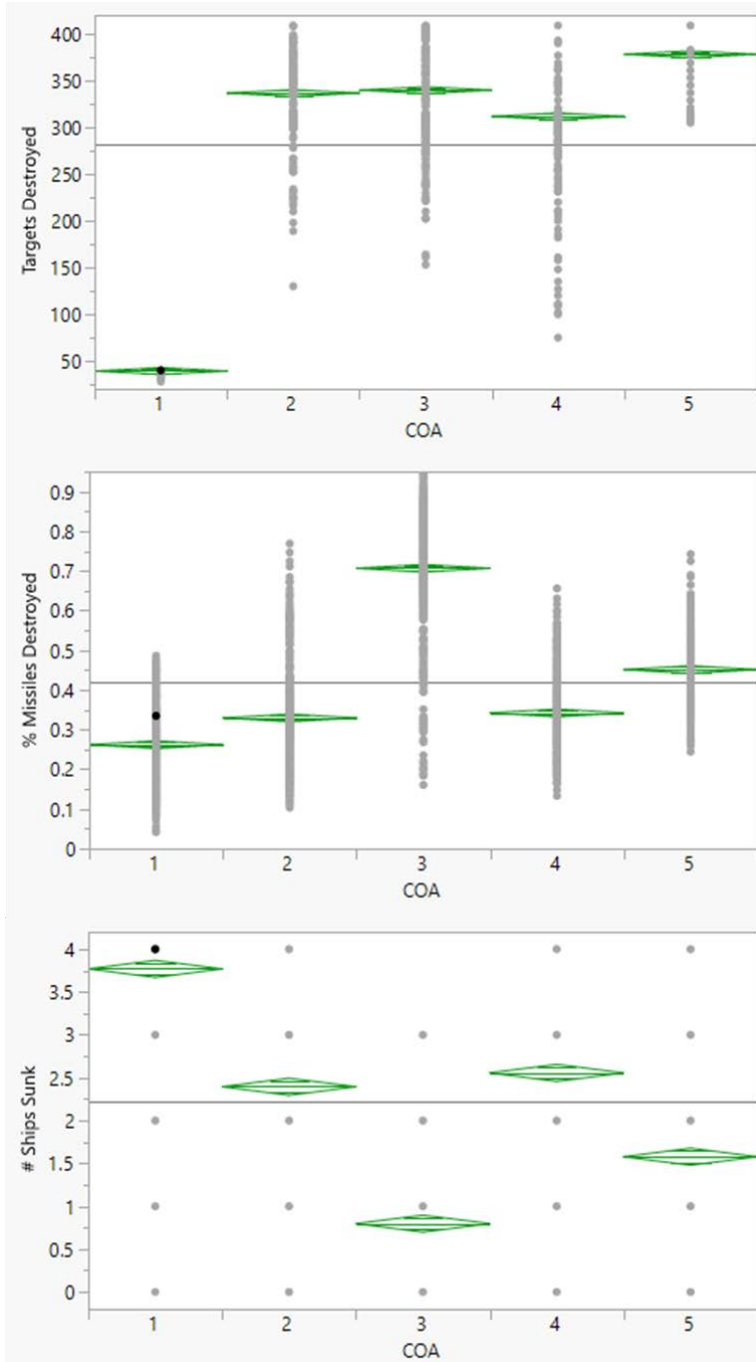

Figure 14. Mean Values for Observed Responses at Medium Enemy Concentration

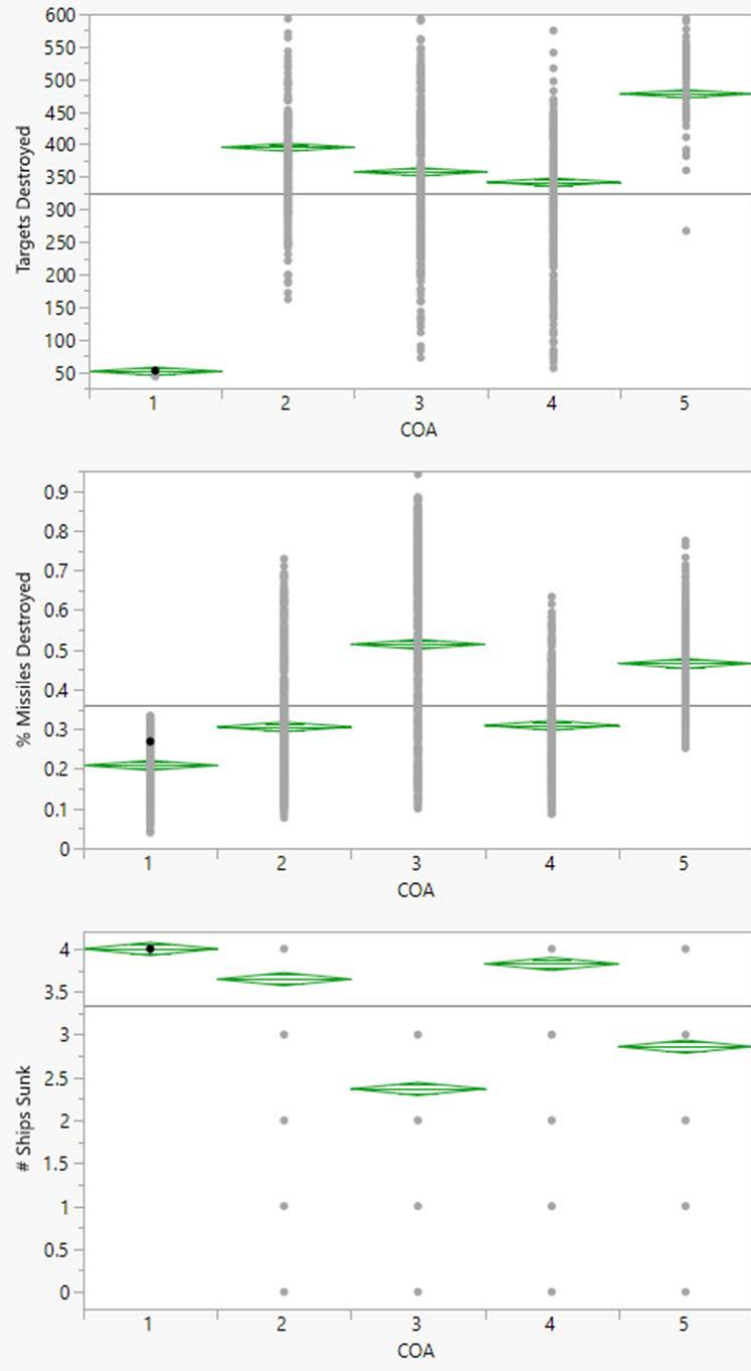

Figure 15. Mean Values for Observed Responses at High Enemy Concentration

B. REGRESSION ANALYSIS

Using the data produced by the 15 DOE simulation runs, regression models were created using JMP Pro in order to determine the impact of the input factors on the observed responses. The least squares method was applied to each COA and enemy concentration level data set, and included second order factorial and polynomial interactions to capture any potential non-linear effects.

The coefficient of determination, or R^2 , values were recorded for each regression model, as seen in Table 12. R^2 is the statistical measure of the “amount of variability in the data explained or accounted for by the regression model” (Montgomery and Runger 2014, 454). Generally, the greater the R^2 value, the better.

Table 12. R^2 values for observed responses

	Low Enemy Concentration			Medium Enemy Concentration			High Enemy Concentration		
	# Targets Destroyed	% Missiles Destroyed	# ATF Ships Sunk	# Targets Destroyed	% Missiles Destroyed	# ATF Ships Sunk	# Targets Destroyed	% Missiles Destroyed	# ATF Ships Sunk
COA1	0.019	0.83	0.03	0.013	0.93	0.12	0.009	0.93	-
COA2	0.12	0.57	0.11	0.28	0.33	0.18	0.72	0.55	0.22
COA3	0.14	0.71	0.16	0.87	0.83	0.44	0.93	0.87	0.48
COA4	0.13	0.80	0.14	0.52	0.85	0.24	0.89	0.86	0.18
COA5	0.12	0.58	0.14	0.25	0.59	0.23	0.20	0.48	0.17

Based on the R^2 values, the following observations were made:

1) The regression models for “# Targets Destroyed” for COA1 at all enemy concentrations have very low R^2 values. Since COA1 does not include an EMRG, there are only two input factors (“ATF Initial Standoff Distance” and “DDG Support Distance”). Based on the data, any variability of those two factors always results in failure to incapacitate the majority of enemy targets, and thus failure to control the objective area. The DDG weapons loadout and quantity available are the limiting factors, which places an upper bound on the number of targets that could be destroyed, thus driving the response toward a single value. Despite this, COA1 serves as a baseline for analyzing the effectiveness of the EMRG, as intended.

2) The regression models for “# Targets Destroyed” for COA2 through COA5 at the low enemy concentration have very low R^2 values. Based on the data, any variability in the input factors nearly always results in all targets being destroyed, or successfully controlling the objective area, hence driving the response toward a single value.

3) The regression models for “% Missiles destroyed” for all COAs and enemy concentrations generally have moderate to high R^2 values. For example, Figure 16 shows the predicted responses of the regression model for COA4 at the high enemy concentration versus the actual responses output by the DOE simulation. As can be seen, there is a strong linear relationship, indicating that the model fit is appropriate. The residual plot for the same regression model, as shown in Figure 17, also displays a good random pattern of error for the predicted responses within $\pm 10\%$ of the actual responses. Similar results were observed for all other cases.

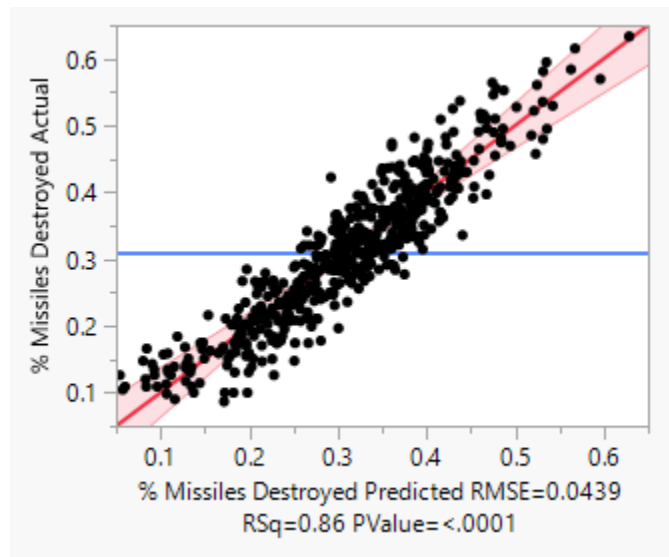

Figure 16. COA4 (High Enemy Concentration) Predicted versus Actual Response for % Missiles Destroyed

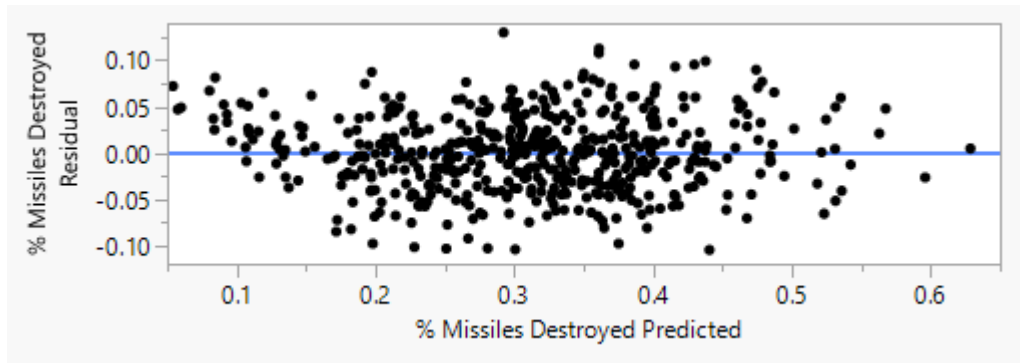

Figure 17. COA4 (High Enemy Concentration) Residual Plot for % Missiles Destroyed

4) The regression models for “# ATF Ships Sunk” for all COAs and enemy concentrations generally have low R^2 values. However, it was observed that all input factors that affect “% Missiles Destroyed” also affect “# Ships Sunk,” and that the two responses are inversely related. In other words, as “% Missiles Destroyed” increases, “# ATF Ships Sunk” decreases.

5) Although the results in Table 11 indicate that COA5 is the most effective at destroying targets, the R^2 values for those regression models are low. Examination of the residual plots displayed patterns of error in the regression, meaning that there may be factors within the ExtendSim model other than those selected for the DOE matrix that are affecting the observed responses. As an example for comparison, Figure 18 shows the predicted and residual plots for COA3 at the high enemy concentration, which has an R^2 value of 0.93. A linear relationship between the predicted and actual values is evident, as is the randomness in residual error. In contrast, COA5 at the high enemy concentration, which has an R^2 value of 0.20, shows a lack of relationship between the predicted and actual values and a pattern of residual error, as seen in Figure 19.

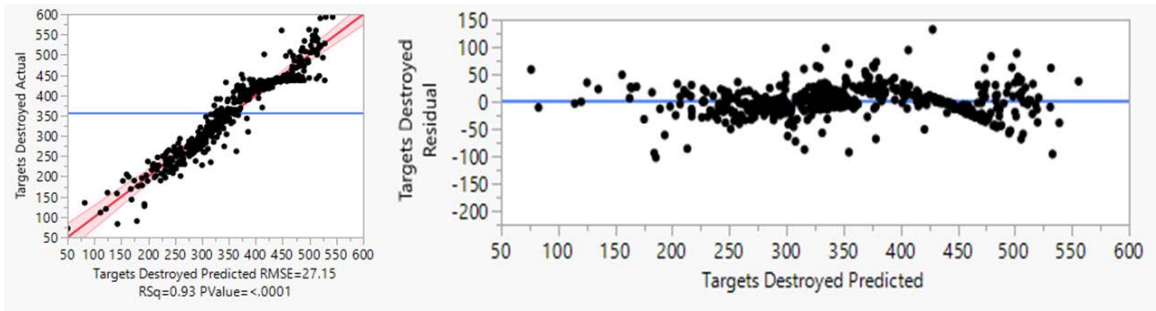

Figure 18. COA3 (High Enemy Concentration) Predicted and Residual Plots for # Targets Destroyed

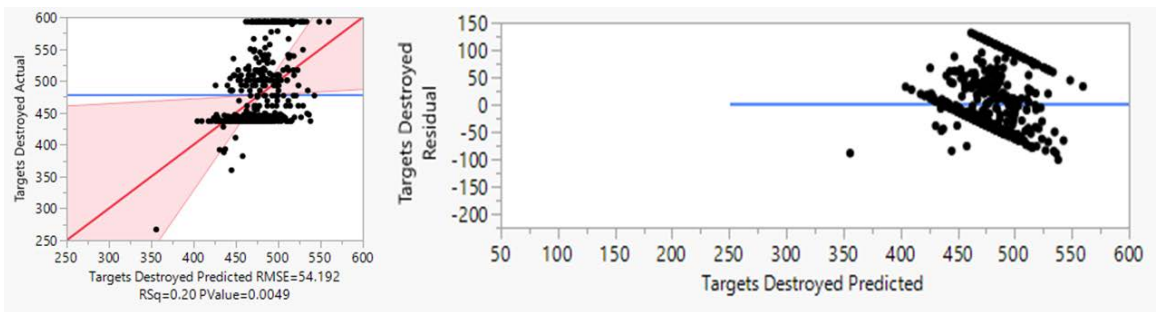

Figure 19. COA5 (High Enemy Concentration) Predicted and Residual Plots for # Targets Destroyed

6) COA3 showed the best R^2 values for both medium and high enemy concentrations; therefore, the confidence in the ExtendSim model’s ability to produce useful results is high. For that reason, in addition to its generally good mission performance, the decision was made to conduct further analysis of COA3, which will be discussed in the next section.

C. COA1 BASELINE SIMULATION

In order to establish a baseline with which to compare the mission performance of an EMRG-equipped ATF, 20,000 simulation runs of COA1 were completed at the medium and high enemy concentration levels. As noted in the DOE results, COA1, which does not include an EMRG, performs poorly at all levels of enemy concentration, and the regression analysis identified issues with the models associated with the “# Targets Destroyed” and “# Ships Sunk” responses. The regression models for “% Missiles Destroyed,” however,

showed a strong relationship to the only two input factors—“ATF Initial Standoff Distance” and “DDG Support Distance”—for COA1. Using the prediction profiler in JMP Pro to observe the effects of those input factors, their values were set for the simulations to 10nm and 80nm, respectively, in order to maximize “% Missiles Destroyed.” These values were used for both the low and high enemy concentration levels, as shown in Figure 20 and 21. The simulation results are shown in Table 13, and were used to compare to the COA3 simulation results in Section D.

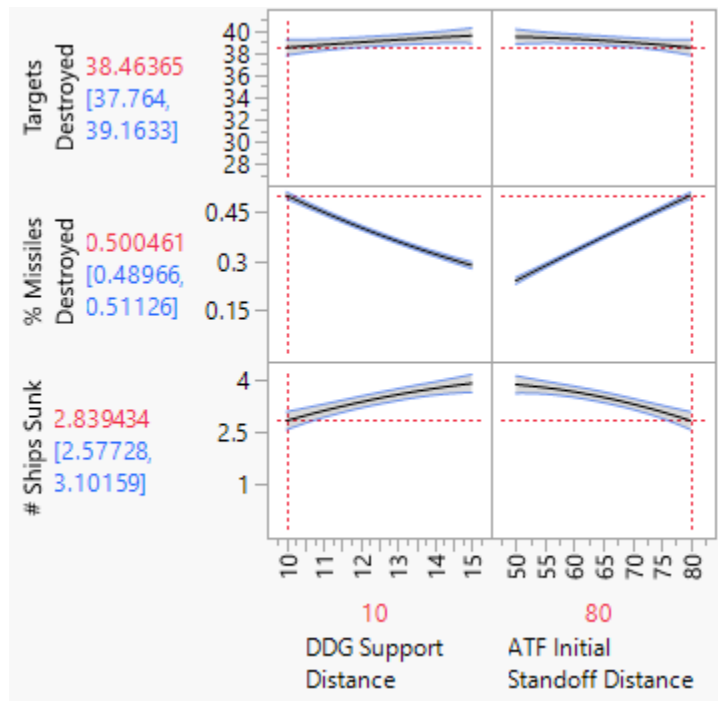

Figure 20. COA1 (Medium Enemy Concentration) Input Factor Prediction Profiler for Desired Responses

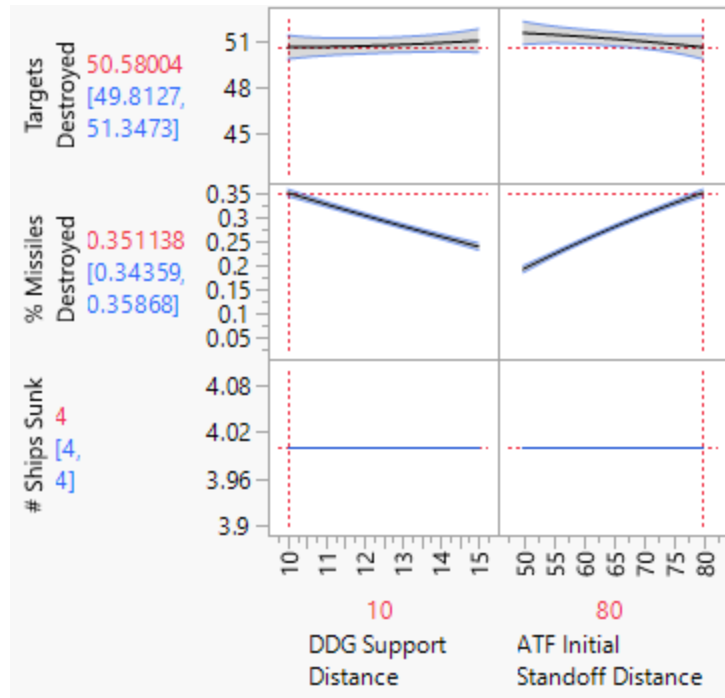

Figure 21. COA1 (High Enemy Concentration) Input Factor Prediction Profiler for Desired Responses

Table 13. COA1 Mean Values for Observed Responses for Large Multirun Simulations

	Medium Enemy Concentration			High Enemy Concentration		
	# Targets Destroyed (out of 409 possible targets)	% Missiles Destroyed	# Ships Sunk	# Targets Destroyed (out of 593 possible targets)	% Missiles Destroyed	# Ships Sunk
Mean	39.23	46.82%	3.05	50.98	32.60%	4.00
Standard Deviation	1.61	1.73%	1.17	1.94	0.70%	0.02

D. COA3 MISSION DESIGN AND ANALYSIS

Initial regression analysis of the DOE simulations showed that COA3 exhibited the best R^2 values for both medium and high enemy concentrations; therefore, COA3 was further explored and analyzed and its results were used to compare against the COA1 baseline results. Since the number of factors (including second order interactions) for COA3 totaled 54, stepwise regression using the minimum Bayesian information criteria (BIC) method was performed. This was done in order to narrow the complete list down to

the factors and interactions that had the largest impact on the observed responses, and to create refined regression models based on those significant factors. The selected significant factors included those within the desired 90% confidence level (CL), or alpha of 0.1 (where alpha = 1 – CL). The stepwise regression showed that cycle time, various probabilities of hit, number of EMRGs, firing scheme, and initial ATF standoff distance are the factors that have the largest influence on the performance of the EMRG. As an example, Figure 22 shows the significant factors and interactions for the “# Targets Destroyed” response at the medium enemy concentration level, as well as their p-values, where a p-value that is less than alpha denotes that it has a significant impact on the response. Since all p-values are below the standard of 0.1, the LogWorth for each factor is also shown, which further differentiates the relative impact of each factor and their influence on the observed responses. Appendix B contains the complete list of significant factors for all observed responses at both the medium and high enemy concentration levels. Once the significant factors were determined, refined regression models for the observed responses were created. Because the number of factors was reduced, the R² values for those models were also reduced, as shown in Table 14. The differences are not substantial, but worth noting.

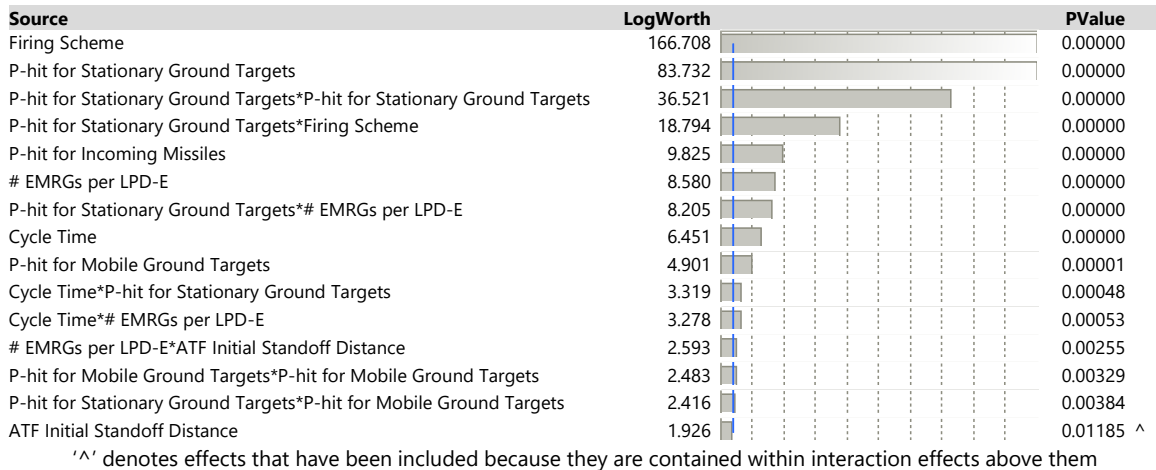

Figure 22. COA3 (Medium Enemy Concentration) Significant Factors for # Targets Destroyed

Table 14. R² Values for COA3 Refined Regression Models

	Medium Enemy Concentration			High Enemy Concentration		
	# Targets Destroyed	% Missiles Destroyed	# Ships Sunk	# Targets Destroyed	% Missiles Destroyed	# Ships Sunk
COA3	0.85	0.80	0.40	0.90	0.83	0.38

Figures 23 and 24 show snapshots of the prediction profiler tool in JMP Pro for the medium and high enemy concentrations, respectively. These graphically represent the effects that the factors have on the responses as their values are adjusted up or down. This tool was used to determine suitable input factor values for the 20,000-run simulations in order to maximize the response values. The predicted values are shown on the y-axes, along with the 95% confidence interval values. Tables 15 and 16 show the selected input values for the medium and high simulations, respectively. Note that “Velocity” was not a significant factor and was set to a value of Mach 5.8, which is the equivalent of a 32MJ EMRG as opposed to a higher velocity 64MJ EMRG. Likewise, “P-hit for Moving Aircraft” was also insignificant and was set to the median of the explored range of values in the DOE. These decisions were made based on the potential cost benefit of designing the EMRG to lesser requirements. It is also notable to highlight that the p-hit values at the medium concentration do not need to be maximized in order to achieve the predicted values, as indicated by the vertical red dashed lines in Figure 23. Lastly, the predicted value for “# Ships Sunk” is less than zero, which is obviously not possible. Based on the interactions and relationships between the factors and responses, attempting to set this response to zero results in a tradeoff of reduced “# Targets Destroyed” and “% Missiles Destroyed.” Therefore, the negative predicted value was accepted.

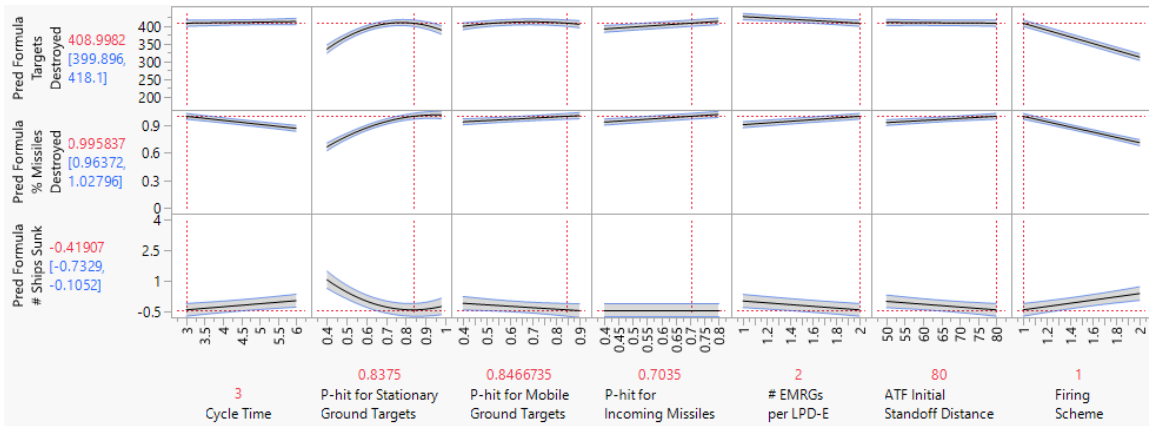

Figure 23. COA3 (Medium Enemy Concentration) Input Factor Prediction Profiler for Desired Responses

Table 15. COA3 (Medium Enemy Concentration) Input Factor Values for Large Multirun Simulation

EMRG Properties		
Factor	Min	Units
Cycle Time	3	sec
Velocity ¹	5.8	Mach
P-hit for Moving Aircraft ²	0.65	-
P-hit for Stationary Ground Targets	0.8375	-
P-hit for Mobile Ground Targets	0.8467	-
P-hit for Incoming Missiles	0.7035	-
# EMRGs per LPD-E	2	-
Firing Scheme	1	-
ATF Properties		
Factor	Min	Units
ATF Initial Standoff Distance	80	nm

¹ Not a significant factor; set to the minimum value explored in the DOE

² Not a significant factor; set to the median of explored values in the DOE

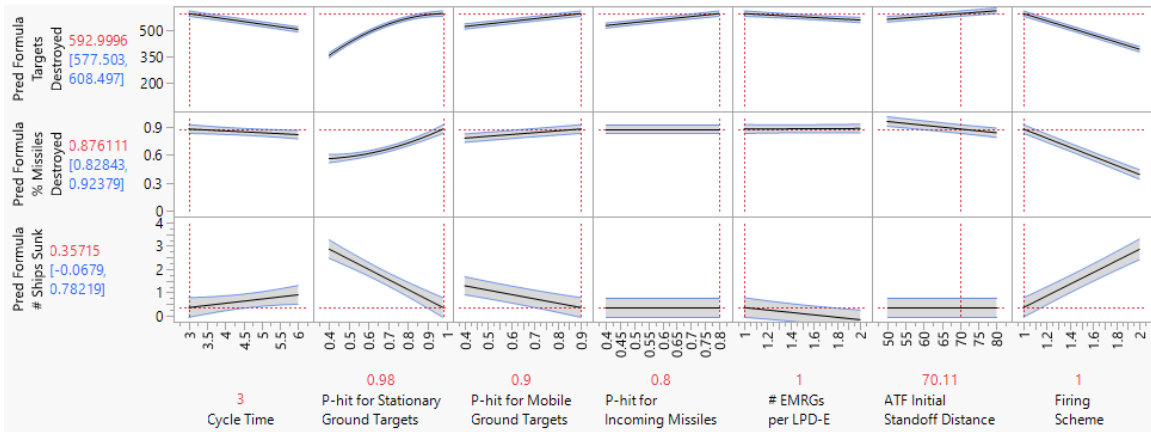

Figure 24. COA3 (High Enemy Concentration) Input Factor Prediction Profiler for Desired Responses

Table 16. COA3 (High Enemy Concentration) Input Factor Values for Large Multirun Simulation

EMRG Properties		
Factor	Min	Units
Cycle Time	3	sec
Velocity ¹	5.8	Mach
P-hit for Moving Aircraft ²	0.65	-
P-hit for Stationary Ground Targets	0.98	-
P-hit for Mobile Ground Targets	0.90	-
P-hit for Incoming Missiles	0.80	-
# EMRGs per LPD-E	1	-
Firing Scheme	1	-
ATF Properties		
Factor	Min	Units
ATF Initial Standoff Distance	70.11	nm

¹ Not a significant factor; set to the minimum value explored in the DOE

² Not a significant factor; set to the median of explored values in the DOE

As an experiment, 20,000-run simulations were also completed for COA3 at medium and high enemy concentration levels using the set factor values. The mean values and standard deviations of the responses were recorded, as shown in Table 17. The mean values for all responses (except for “% Missiles Destroyed” for the medium enemy concentration) fall within the 95% confidence interval of the predicted values.

The observed responses of the simulations for COA1 and COA3 were interpreted against the established MOEs, as shown in Table 18. “Control of Objective Area” is the probability of success based on the number of times that all targets were destroyed across all 20,000 simulation runs. “Enemy Missiles Defeated” is a direct carryover of the mean response of “% Missiles Destroyed.” “ATF Survivability” is the probability that the entire ATF survives and remains intact at the end of the amphibious assault mission, based on the number of times that no ships were sunk across all 20,000 simulation runs. As can be seen, the integration of an EMRG onto an amphibious ship provides a substantial improvement in the capability of conceptual expeditionary advanced base operations over current weapons.

Table 17. COA3 Mean Values for Observed Responses for Large Multirun Simulations

	Medium Enemy Concentration			High Enemy Concentration		
	# Targets Destroyed (409 max)	% Missiles Destroyed	# ATF Ships Sunk	# Targets Destroyed (593 max)	% Missiles Destroyed	# ATF Ships Sunk
Mean	407.43	89.94%	0.05	572.03	83.60%	0.33
Standard Deviation	11.85	2.47%	0.22	47.31	3.84%	0.64

Table 18. Results for Measures of Effectiveness

	Medium Enemy Concentration			High Enemy Concentration		
	Control of Objective Area (%)	Enemy Missiles Defeated (%)	ATF Survivability (%)	Control of Objective Area (%)	Enemy Missiles Defeated (%)	ATF Survivability (%)
COA1	0%	46.82%	3.21%	0%	33.60%	0%
COA3	98.06%	89.94%	95.72%	82.16%	83.60%	75.19%

THIS PAGE INTENTIONALLY LEFT BLANK

V. CONCLUSIONS

A. PROJECT FINDINGS

The goal of this capstone report was to investigate the potential operational effectiveness of an amphibious ship equipped with an EMRG when conducting an amphibious assault mission. This developmental weapon differs from the current arsenal of naval weaponry by utilizing electromagnetic propulsion to launch kinetic rounds at great distance as opposed to the use of chemically propelled missiles. There is currently interest in developing a non-missile guided long-range defensive protection against threats and sustainable ship-to-shore fire support from distances greater than 30nm. In order to measure the potential benefits that this weapon system could have, Team Longshot began by conducting research of current naval planning doctrine, weapon development reports, existing capabilities, and the possible emergent threats the future naval fleet may face. The decision to implement the EMRG aboard an LPD San Antonio class ship was intended to help strengthen the multi-mission capability of the already versatile ship. In order to help structure the efforts, Team Longshot created a tailored engineering process to establish a CONOPS using mission engineering. This singular focus on the mission would reveal the operational performance of an amphibious task force using EABO concepts and test the theoretical capabilities of the EMRG. The mission engineering process tailored for this capstone led to the creation of an amphibious assault simulation using naval, air, and land force models for the opposing forces in the simulated battle.

After establishing the capstone process, objectives, and operational concept, Team Longshot evaluated the stakeholder needs in relation to the EMRG weapon to generate a prioritized list of needs that were translated into a structured list of functional requirements. The architecture hierarchy was decomposed and related to the ships, aircraft, and landing force in Innoslate to define and organize the simultaneous actions each model performs for the duration of the assault mission. Five possible ATF compositions were proposed to highlight the different courses of action available to force planners to create a wide spectrum of possible inputs. Each of these COAs were simulated against various enemy strengths to test the EMRG capabilities and to determine the appropriate course of action

for an amphibious assault given the assumptions and inputs shown in Chapter III. The outputs of these five COAs were measured against the effectiveness and performance objectives shown in Table 3. Many of the inputs were assigned ranges that could vary between the thousands of simulations to generate numerous data points used in the analysis of alternative inputs and COAs to determine the most influential parameters contributing to the ATF completing the assault mission. The results of the input value sensitivity analysis revealed the most important factors for each course of action and the best performing ATF selections were ones that included one or more EMRGs. Figures 23 and 24 show that the most influential factors of the EMRG were the cycle time, various probabilities of hit, number of EMRGs, firing scheme, and initial ATF standoff distance.

The new weapon capability, as simulated, resulted in improved success of the mission, and with additional EMRGs in the ATF the results showed operational performance increased with the addition of the EMRG. COA3 removed the use of the escort DDG which showed highest mission control of objective percentages, elimination of missile rates, and ATF survivability in the 512 simulation runs. The results of COA1 and COA3 in Table 18 shows that the addition of the EMRG with no DDG escort had increased ATF survivability, missile elimination, and control of objective areas percentages by at least 50 percent on all factors. The simulation indicated the increased range, high firing rate, and lethality of the EMRG may provide a technological edge over future enemy weapons by eliminating threats before they can engage the ATF. The range of the EMRG allowed it to engage targets from distances that permitted reengagements in when necessary and decreased ships' vulnerabilities to enemy fire. The large munitions capacity, low cost-exchange ratio, and electromagnetic propulsion pairs well with the EABO concept by preventing potentially affording the ATF with an increased weapons load-out, expanding the target selection to a wider range of prioritized targets, and increasing survivability by limiting the number of reactive munitions aboard the ship.

B. RECOMMENDATIONS

Team Longshot recommends the further exploration of electromagnetic railguns in future naval operations such as the scenario described in this report. While the widespread

use of this weapon system might provide more sweeping benefits to the naval fleet, this hypothesis was not tested by the capstone team. The recommendation to further investigate the value of the EMRG in amphibious assaults was based upon the simulation results that indicated benefits of the EMRG weapon in engagement ranges, firing rate, and magazine depth. The kinetically propelled EMRG projectile provides a new option that could hit targets with over-the-horizon attacks using rapid firing profiles by shooting multiple times before confirming target elimination. The theoretical rates of fire for the EMRG used in the simulation outmatched currently available weapons. The ATF composition that included two EMRGs was able to successfully complete 300 out of 500 of the mission simulations against the highest enemy force strengths. ATFs that contained one EMRG only successfully completed the mission in 150 out of 500 simulations.

One of the most influential factors in the simulation was the accuracy and precision of the EMRG weapon against various target types such as enemy missiles, ground targets, and aircraft. The EMRG fires a GPS-aided projectile that can adjust mid-flight to guide the round more accurately to land targets by using control fins. The complexities in engaging missiles and moving aircraft limit the engagement window, and EMRG rounds used in missile defense are not GPS guided. This factor was included in the simulation with the engagement ranges and hit percentages per each enemy target for the EMRG. The advancement of this technology may greatly increase the performance of the weapon and its operational effectiveness.

Another contributing factor in the success of the mission simulation is the cycle time of the EMRG when firing rounds. The cycle time input for this simulation ranged between 3 and 6 seconds which is directly linked to the power generation capability of the EMRG weapon system and the firing range required. Shorter ranges expend less energy in the storage capacitors which allows for more rapid firing of the EMRG. Higher power generation of 64 MJ for the EMRG would further reduce the cycle time and increase engagement ranges. Integration of the support components for a high power rated EMRG may not be possible for retro-fitting amphibious ships, but Team Longshot recommends further research and development into the possibility of utilizing different energy ratings for EMRGs to be used aboard other naval ships including the SAG and submarines.

C. FUTURE RESEARCH TOPICS

The EMRG weapon system is a developmental weapon that entered preliminary testing of prototypes in 2015 (O'Rourke 2019). Electrically powered weapons fall into a new class of armaments that break from the traditional chemically propelled artillery and launched missile projectiles. So far, a weapon that uses electromagnetic propulsion has not been implemented in a large scale battle which caps the technology readiness level, but prototypes, advanced theories, and modeling and simulation efforts (including this report) are needed to advance the technology to a point in which it can be implemented aboard naval fleets, fixed land sites, mobile ground vehicles, and other possible applications not previously considered.

1. EMRG INTEGRATION

A significant limiting factor to the wide-spread use of this weapon is the power generation requirement, energy storage, cooling, munition auto-loading, rail reliability, and maintenance required to operate the weapon system. Likewise, the number of rounds available on the ship and the ability to replenish at sea will increase the value of the EMRG by ensuring sufficient availability for mission loadout. The simulation logged the number of EMRG shots expended during successful missions and they ranged from 1117 to 1570 depending on the enemy force concentration. If ship integration does not allow for a minimum of 1600 EMRG rounds, then the ATF may be faced with a situation where the ATF must be resupplied. The eventual employment of the EMRG extends beyond considerations of the performance of the system to the complexities of design and implementation required to integrate the weapon into already existing naval platforms. While space and weight allocation information for the EMRG and its necessary sub-systems were not available at the time of writing, these potential limitations are important when considering the integration of the weapon system. These considerations are significant when pounds and cubic feet are limited and when weight and space allocations must be carefully assigned to naval ships, aircraft, and ground vehicles. Additional research should be performed to determine the appropriate EMRG integration scheme for each host platform.

2. EMRG LIMITATIONS WITH SUBSYSTEMS

The support component of EMRG autoloading and munitions handling was not considered in this simulation and could be another limiting factor in the firing rate of the new weapon. Increases in energy production/storage and rail cooling technologies can allow for higher firing rates but if the munitions-handling or autoloading assembly are unable to match other weapons capabilities then the weapon will remain limited in its capacity to maintain high rates of fire. The simulation and design of experiments show that firing rate was one of the top factors that determined the overall operational effectiveness of the EMRG weapon. Additional research should be performed to determine the limiting factors of EMRG performance to ensure future efforts are focused appropriately on subsystem technology advancements.

3. MODELING AND SIMULATION IMPROVEMENTS

Several assumptions were applied in the capstone effort to bound the simulation to the most influential factors in the amphibious assault mission. The context diagram from Figure 8 outlines some of the external systems that should be considered in future naval operations but were not included in this amphibious assault simulation. Likewise, the simulation does not include enemy naval or air forces such as ships, sea-based mines, or long-range missiles. The simulation assumes that an LCS equipped with mine countermeasures and allied forces have cleared the way for the ATF to establish control of the enemy shoreline which eliminates many outside influences. A larger scale simulation supported by sufficient server processing for calculations should be performed to simulate the entire naval campaign instead of the singular assault mission.

Since the EMRG is considered a developmental weapon, many of the actual values were assumed based on unclassified sources gathered by Team Longshot. The inputs to the simulation are just as important as the outputs because inaccurate entry data can skew the results of the simulation by providing false outcomes. The EMRG input parameters are based on the projected possible performance measures after EMRG technology maturation, but EMRG performance characteristics are highly speculative. Likewise, enemy parameters of force concentration and system performance are based upon open sources

that estimated capabilities in the 2030 timeframe. More realistic, mission specific inputs are needed to provide accurate and precise results for the performance of the ATF. It is recognized that this would require the simulation to access and unused classified data and would limit distribution. For this study, subject matter experts in the field of naval combat and the EMRG provided Team Longshot insight and guidance that was incorporated into the models and simulation.

The input values and simulation relationships were reviewed by stakeholders and naval experts to create a close approximation of the theoretical values for the EMRG. More accurate values may be revealed as the EMRG continues along its technology maturation cycle which would require future revisions to the simulation. Additional modeling and simulation should be performed as EMRG technology matures.

4. FUTURE RESEARCH SUMMARY

The efforts of this report suggest that the addition of one or more EMRGs to an EAB launched task force might achieve amphibious assault objectives with swifter, cost-effective, and sustainable attacks from a weapon capable of over the horizon attacks against a range of enemy targets. Although the EMRG is still under development, this new technology may introduce a new long-range capability that is precise, lethal, and capable of sustainable rapid fire against enemy targets. More accurate entry data and enemy profiles can improve the simulation by replicating projected naval scenarios. Integration of the EMRG into existing naval ships will require thorough design planning that considers space and weight allocations of the EMRG and all of its subsystems including autoloading, rail cooling, munitions storage, and energy generation and storage. These developmental concepts and technology requirements are necessary for the maturation of a promising naval EMRG weapon.

APPENDIX A. EXTENSIM 10 MODEL

A. PHASE A—INITIAL FIRING MISSION OR PREPERATION OF THE LANDING AREA BY SUPPORTING ARMS

The ATF's initial firing mission or preparation of the landing area by supporting arms is created for softening targets within the landing zone and the objective area. This firing mission starts a set distance from the objective area within the distant retirement or close support area (see Figure 6). In this creation portion of the model low, medium, or high concentrations of targets are available for the mission and are predefined within the model's database (see Figure 25).

Initial Firing Mission Creation

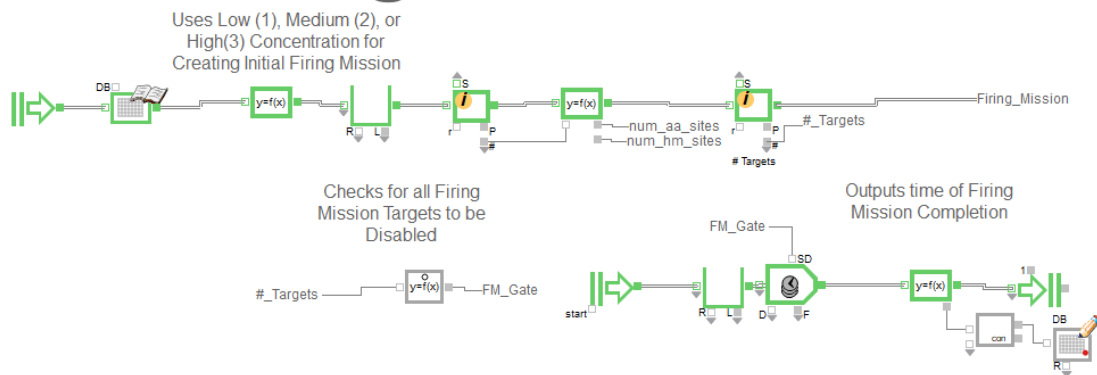

Figure 25. Creation of Initial Firing Mission with Ability to Output time of Completion

Enemy targets are initialized a random distance from the blue force ATF within the objective area and landing zone. These targets are then fired upon based on availability of round or missiles and wait time in the targeting queues for both the firing mission targets and missiles. Missiles receive the highest priority and are ranked further based on time to ATF, which allows them to enter the top of the target queue with the firing mission targets (see Figure 26 and Figure 27).

Initializing Targets and Configuring COAs

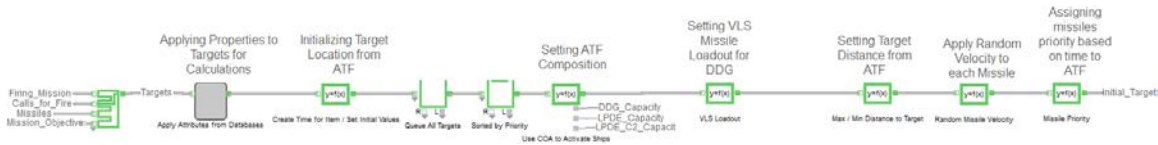

Figure 26. Enemy Targets Initialized and the COA or ATF Configuration Applied

Determining which Ship Engages the Targets Based on Distance and Missile Limits



Figure 27. Determines Ship or Weapon Availability for Engaging Enemy Targets

The enemy then responds after 60 seconds of the engagement beginning with anti-ship missiles targeting the ATF. These missiles are fired from available coastal defense sites that are created within the initial firing mission (see Figure 12). These missiles are then limited to 12 per site and fired in intervals of every 10 minutes. The missiles then have a uniform random delay applied to them of 0 to 100 seconds and uniform random velocities ranging from Mach 5 to Mach 18 to give variability in timing and ATF engagement opportunities to the fires (see Figure 28).

Enemy Response with Missiles Fired

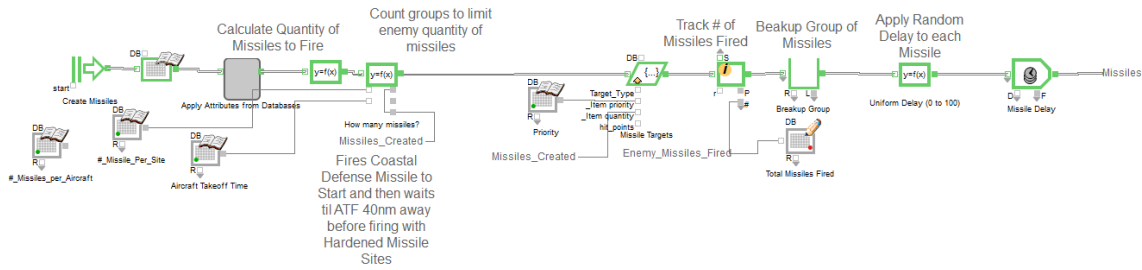

Figure 28. Enemy Missiles Created and Fired Upon the ATF

As the ATF continues to move towards the transport area, the enemy will begin to fire missiles in the same configuration as above. This missile availability will be determined by the available hardened missile or coastal defense sites that are unable to be engaged by long-range fires and must be engaged by the landing force to be disabled, which occurs during Phase B. This allows for enemy to have the capability of disabling the ATF ships when they are at a closer distance to the landing zone (anti-ship missile sites not known to the ATF) and limits engagement time further with the enemy missiles.

An example of the engagement of targets by the LPD-E-C2 can be seen in Figures 29–31. This same process occurs for the LPD-E and the DDG when available. Figure 29 shows how the ships are checked for where the targets will be the most quickly engaged. It includes the amount ground or missile targets engaged with each of the capable ships and limits in round quantity available for each ship, which is assumed to be 1600 rounds.

LPDE_C2 Checks for Moving Target to LPDE

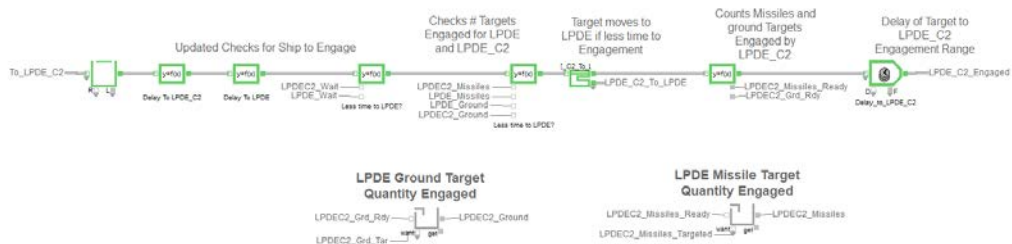

Figure 29. Targeting Queue Delay Time and Rounds Checked for the LPD-E and the LPD-E-C2

The target is then routed from here for either ship to engage (see Figure 30). During this engagement, if there is a change in target types from ground to missiles, then a slight delay of 2 to 5 seconds is added to the cycle time to assume for targeting system changes on the ship. After this targeting is complete, the initial fire time is then saved for calculation of response time for the target based on the target’s creation time. Distances to the target are rechecked to account for delays before completing the targeting process and a recheck of the time to missile engagement is completed. If the recheck to missile engagement is considered too close (2 miles plus the support distance if considered a support ship) then the missile is considered a leaker and routed to the ATF for hit or miss calculations (see Figure 33). Other targets are then applied a time to target if not too close for engagement, which is applied to the final fire delay time after completing the firing sequence (see Figure 31).

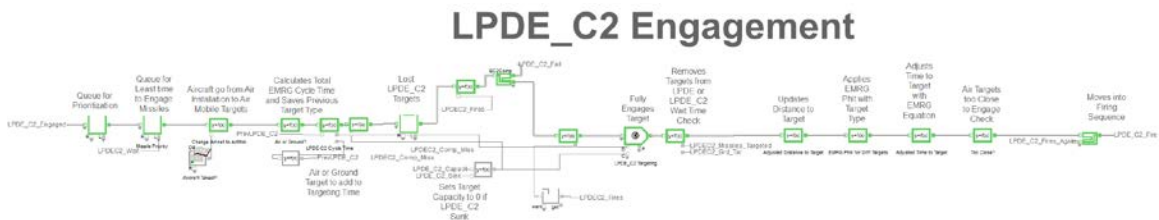

Figure 30. LPD-E-C2 Engagement with Ground and Missile Targets

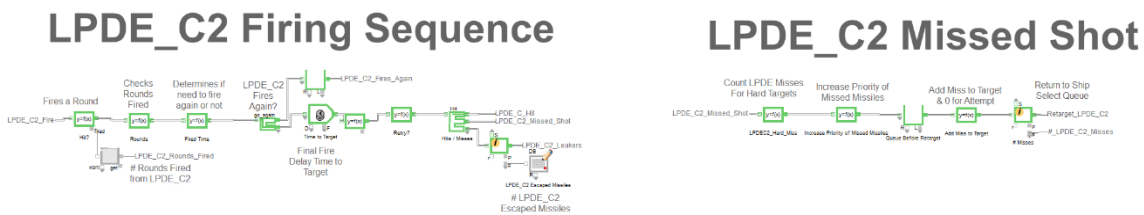

Figure 31. LPD-E-C2 Firing and Missed Shot Process

Within the firing sequence, the target is checked for hits or misses and fired upon a set number of times based on established hit points of the target and the CONOPS situation

of either shoot, shoot, look or shoot, look. If the total number of actual hits is equal to or greater than the amount of hit points, then target is considered disabled and moved to the count for hits (see Figure 32). If the target is not disabled, then it is moved to the missed shot process of the model and if a missile, has an increased priority applied to it, else priority is the same (see Figure 31). From here, the target or missile is then sent back through the queuing and engagement process (see Figure 27).

LPDE_C2 Hits

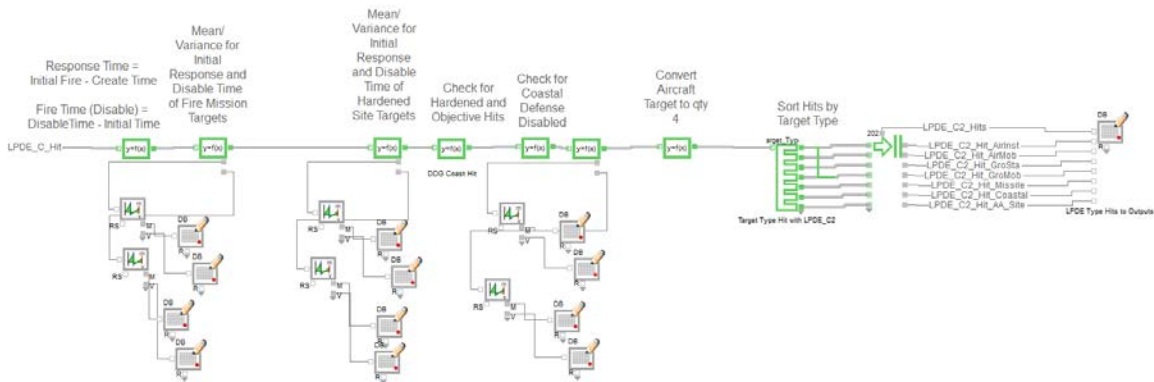

Figure 32. LPD-E-C2 Target Hits Sorted by Type with Calculations for Response Time and Disable Time from Initial Response

Leakers for Ship Sink or Miss

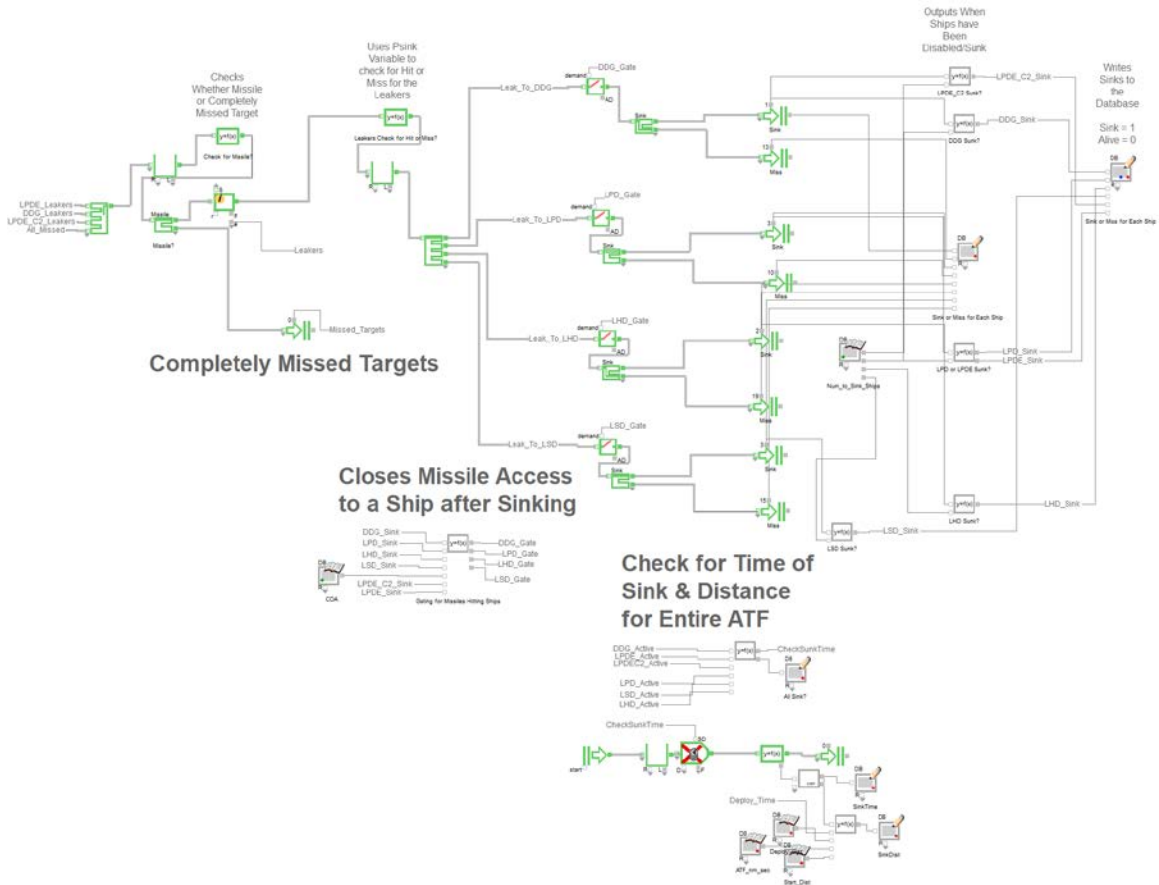

Figure 33. ATF Checked for Hit or Miss by Leaked Enemy Missiles

The leakers that escape the ships are calculated to be either a hit or miss against an ATF ship (see Figure 34). During this process, it is assumed that the ATF has the ability to engage the missiles when they are too close and there is a 90% chance of effectively disabling the missile. When a missile gets past this last line of defense it is then considered a hit against an ATF ship. The ATF ships all have equal probabilities of the enemy missiles being routed to them and all ships can only take 3 hits before being considered disabled. After a ship is disabled it is unable to accept any further enemy missiles and instead those enemy missiles are routed to the available ships, allowing for the enemy to have an advantage against the ATF.

B. PHASE B—ATF ARRIVAL AT THE OUTER AND INNER TRANSPORT AREA AND BUILDUP OF LANDING FORCE

As the model simulation reaches the deployment time, which is based on start distance of the ATF from the landing zone, its average movement speed of 22 knots or 0.0061 nautical miles per second, and the required deployment distance from the landing zone depending on the method of transportation being used (see Figure 34). AAVs have a separate required deployment distance of 2 nautical miles required in order to be most effective and for that reason do not deploy until sometime after the LCACs are available to deploy (see Figure 35). AAVs will not deploy if the LSD has been disabled. There is also a 95% reliability given to the AAVs to account for any factors that may prevent arrival of an AAV to the landing zone.

Start Time for Phase B

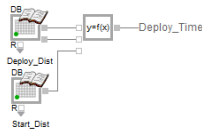

Figure 34. Start Time Calculated for Phase B or Landing Force Deployment

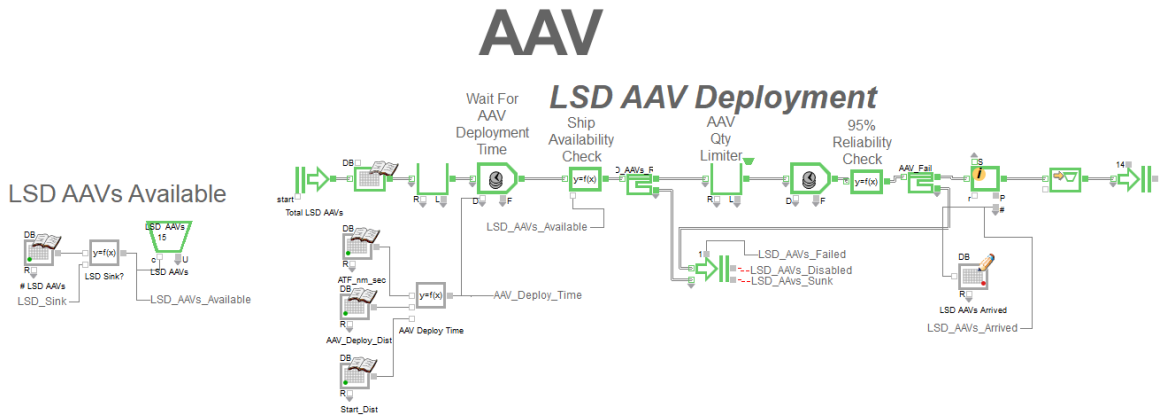

Figure 35. AAV Deployment Process

LCACs will deploy only if the LPD or LHD ships have not been disabled and are given a 90% reliability to account for any issues again with arriving at the landing zone (see Figure 36). LCACs account for a sizable buildup of the landing force with the capability to transport larger vehicles and weapons. The MV-22s will then also transport troops and smaller vehicles at the same time as the LCACs if the enemy anti-air targets have all been disabled (see Figure 37). The MV-22s deploy from all the ships to help with rapid buildup of troops at the landing zone.

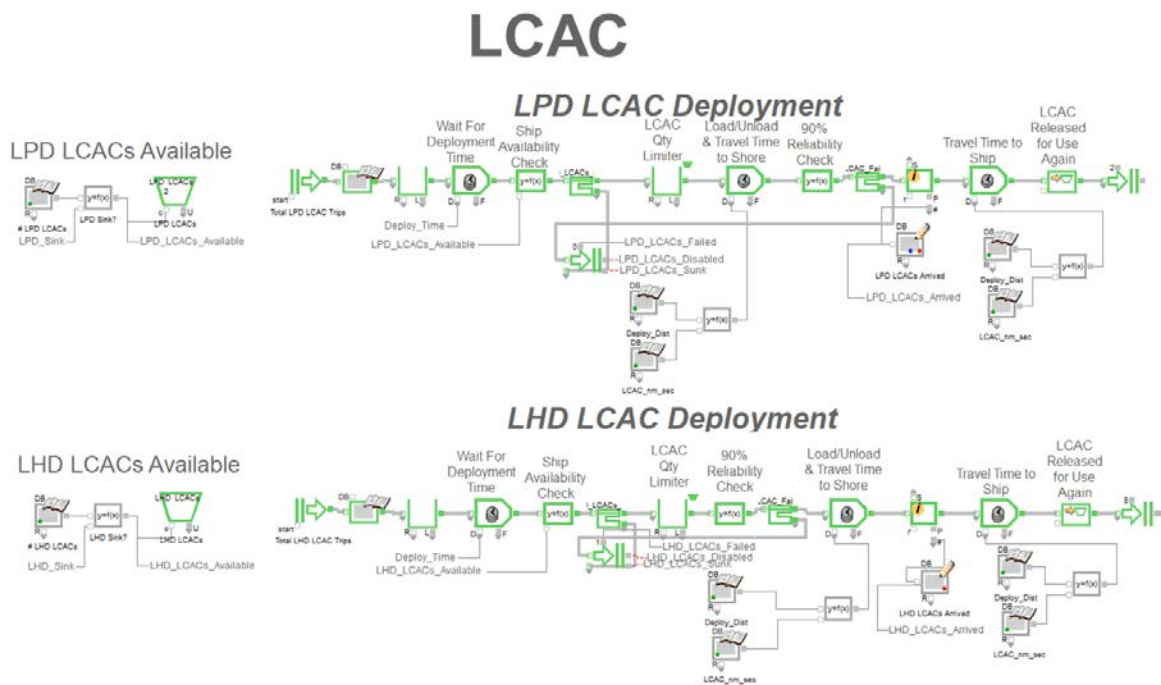

Figure 36. LCAC Deployment Process

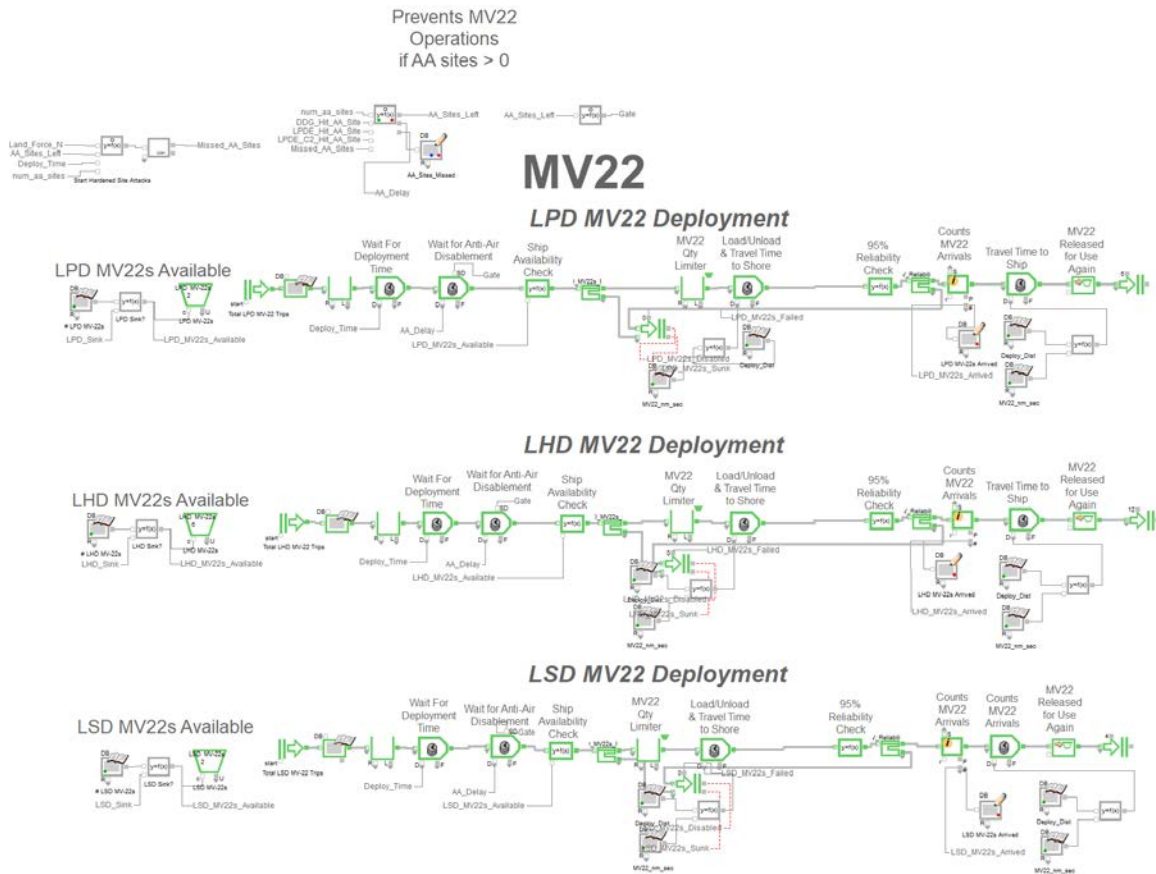

Figure 37. MV-22 Deployment Process

Buildup of the friendly landing force continues as available and is calculated with landing force number points applied to each of the methods of transportation. LCACs get 75 pts each for arrival, AAVs get 25 pts each for arrival, and MV-22s get 25 pts for each arrival (see Figure 38). This buildup of the landing force is then used for removing any anti-air assets that were not able to be engaged due to disablement of any ATF capable ships. The required landing force number to remove anti-air assets is calculated at 25 pts per anti-air target still available. For example, if 5 anti-air targets are still available for engagement, then a landing force of 125 pts is required with a delay of 30 minutes added before MV-22s can deploy and assist with building up the landing force. The buildup of the landing force for Phase B continues during Phase C and for that reason landing force buildup normally ends after Phase C.

Buildup of Friendly Landing Force

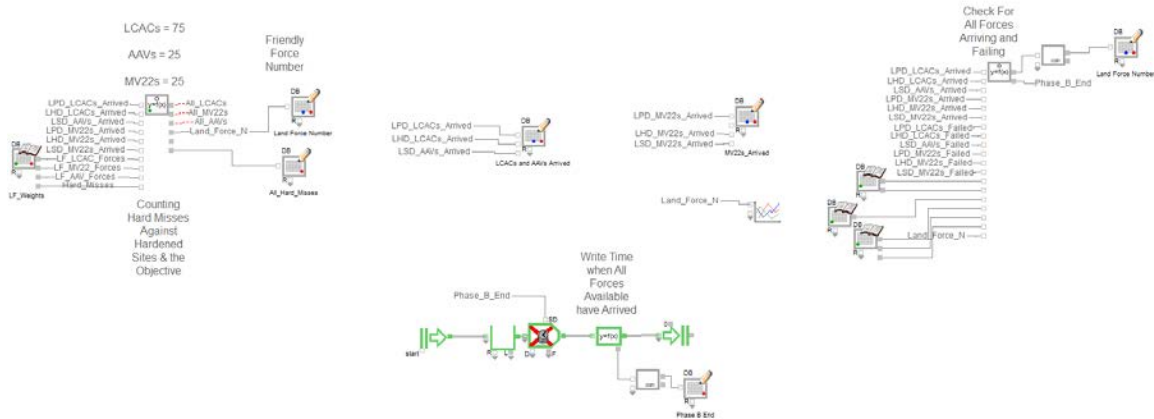

Figure 38. Buildup of Friendly Landing Force

C. PHASE C—DISABLING HARDENED MISSILE SITES AND OBTAINING THE OBJECTIVE

As the landing force number builds up, the hardened missile or coastal defense sites that were unable to be engaged by the ATF, are now engaged by the landing force. With the arrival of at least a force number of 200, the first hardened missile site is able to be engaged (see Figure 39). Every consecutively available hardened site then requires increments of another 200 for the landing force number. For example, to engage 3 hardened missile sites, requires a landing force number of at least 600. Total number of hardened sites available for engagement are based on enemy concentration chosen before beginning the simulation. They range from 5 at the low concentration, 10 at the medium concentration, and 15 at the high concentration. As each hardened missile site is engaged, 8 targets are released into the engagement process with a uniform random delay between 0 and 1800 seconds. Those 8 targets are given a uniform random target type of ground mobile or ground stationary. This allows for full engagement of the hardened missile site within 30 minutes. These targets must then be disabled by the capable ATF ships before the hardened missile site is considered disabled and removed from the enemy capability for firing missiles at the ATF.

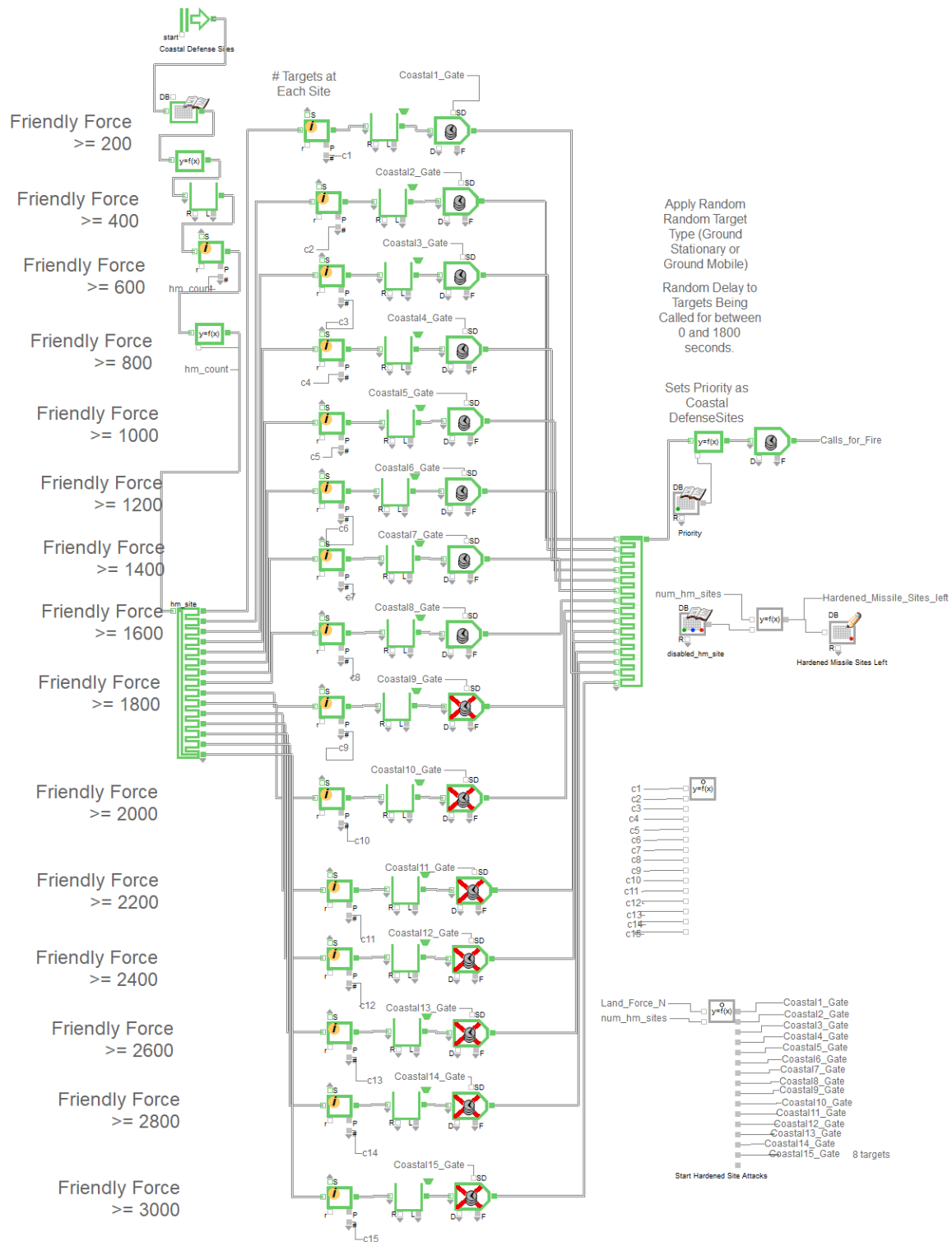

Figure 39. Calls for Fire to Assist with Disabling Enemy Hardened Missile or Coastal Defense Sites

After all hardened missile or coastal defense sites have been disabled the landing force may now start to take the objective. The initialization of the objective creates either 12, 24, or 36 targets if either a low, medium, or high enemy concentration was input within the database before the start of the simulation (see Figure 40). These targets are given again a uniform random distribution of either ground mobile or ground stationary for target type and are uniform randomly distributed within 1 hour of the initialization for taking the objective. With the taking of the objective, if all targets have been defeated by the ATF, the mission is considered a success, else it is considered a failure due to targets being left that the ATF was unable to engage due to the ATF NSFS capability being unavailable.

Calls for Fire Against the Objective



Figure 40. Calls for Fire against Hardened Objectives

APPENDIX B. REGRESSION ANALYSIS SIGNIFICANT FACTORS

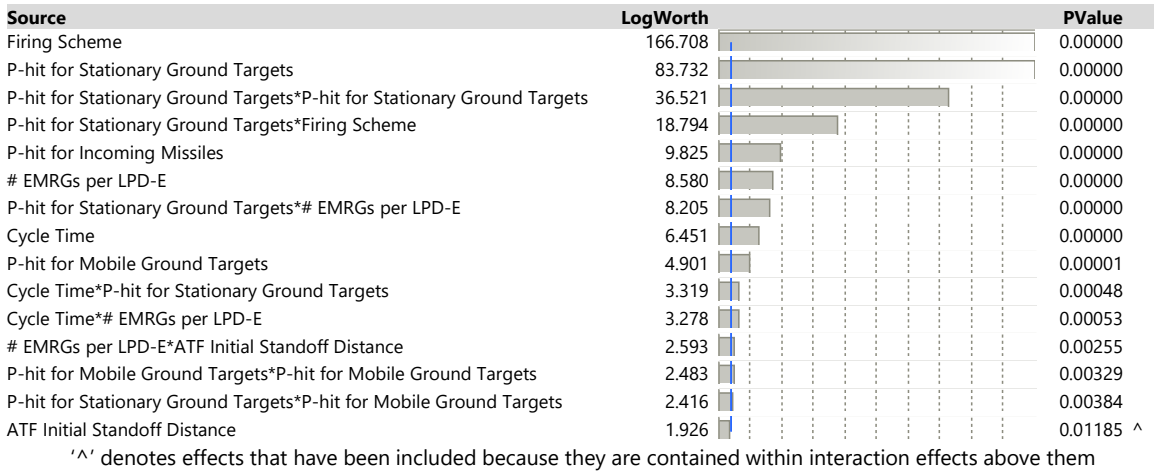

Figure 41. COA3 (Medium Enemy Concentration) Significant Factors for # Targets Destroyed

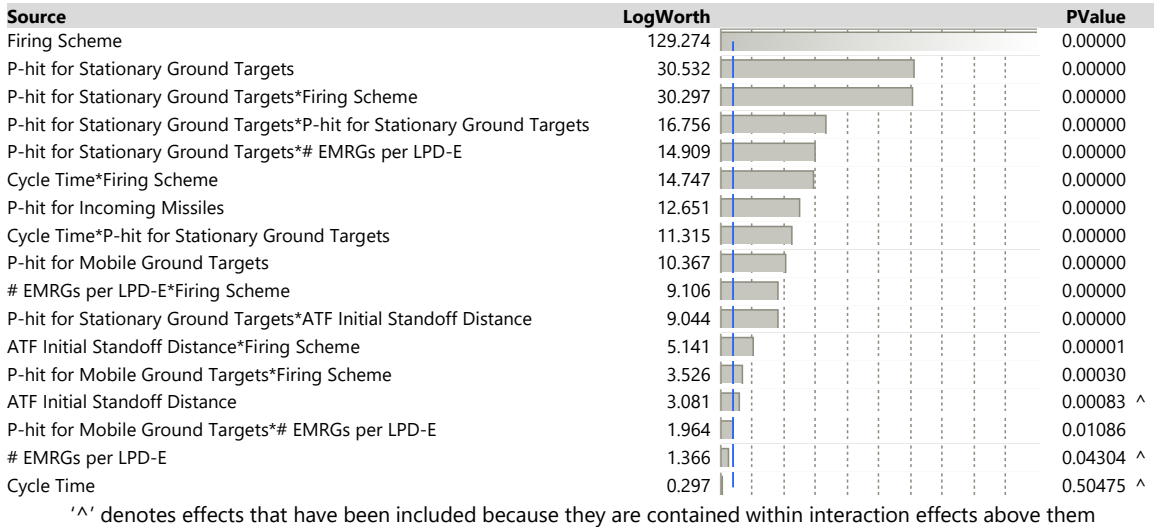

Figure 42. COA3 (Medium Enemy Concentration) Significant Factors for % Missiles Destroyed

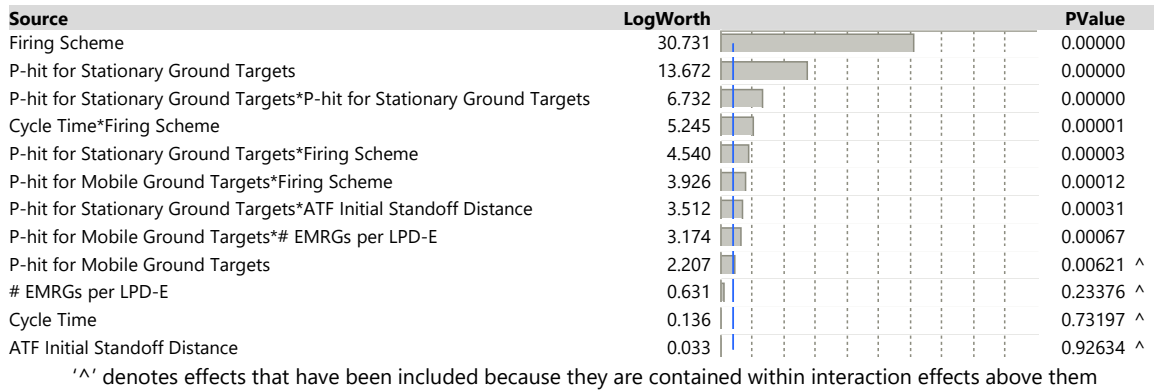

Figure 43. COA3 (Medium Enemy Concentration) Significant Factors for # ATF Ships Sunk

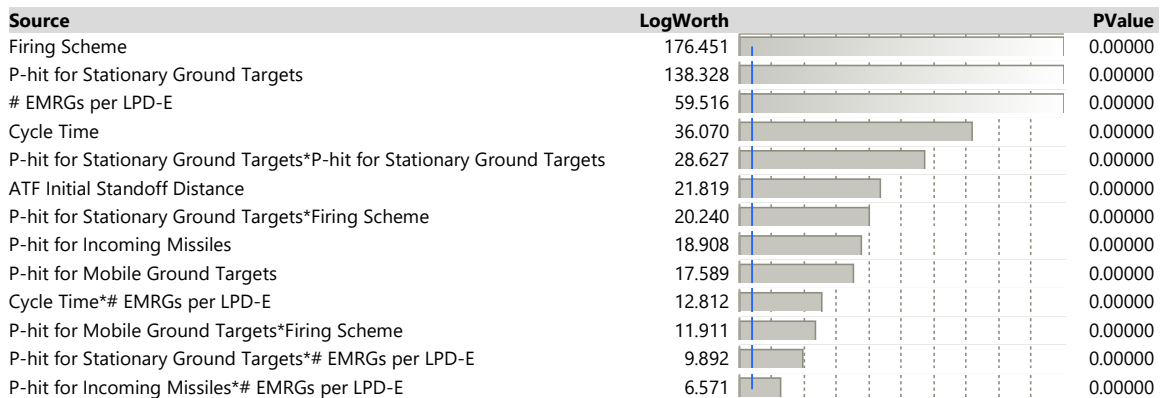

Figure 44. COA3 (High Enemy Concentration) Significant Factors for # Targets Destroyed

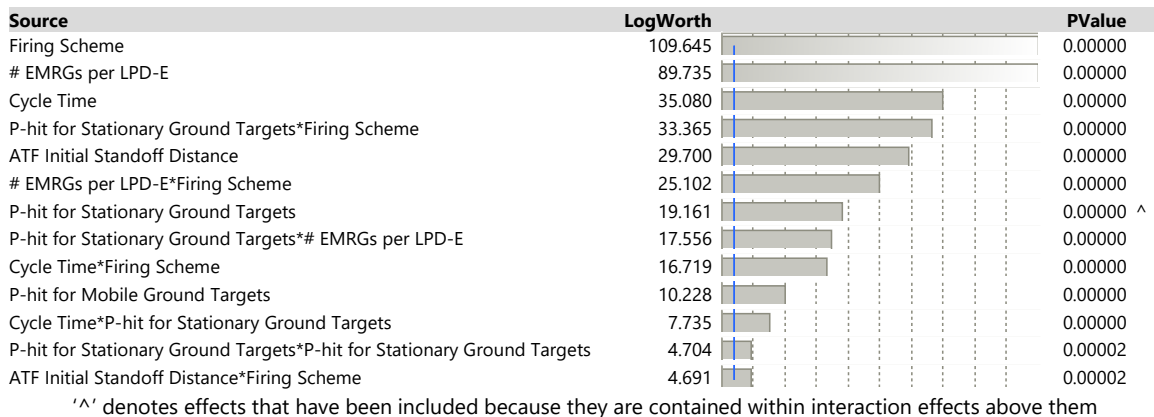

Figure 45. COA3 (High Enemy Concentration) Significant Factors for % Missiles Destroyed

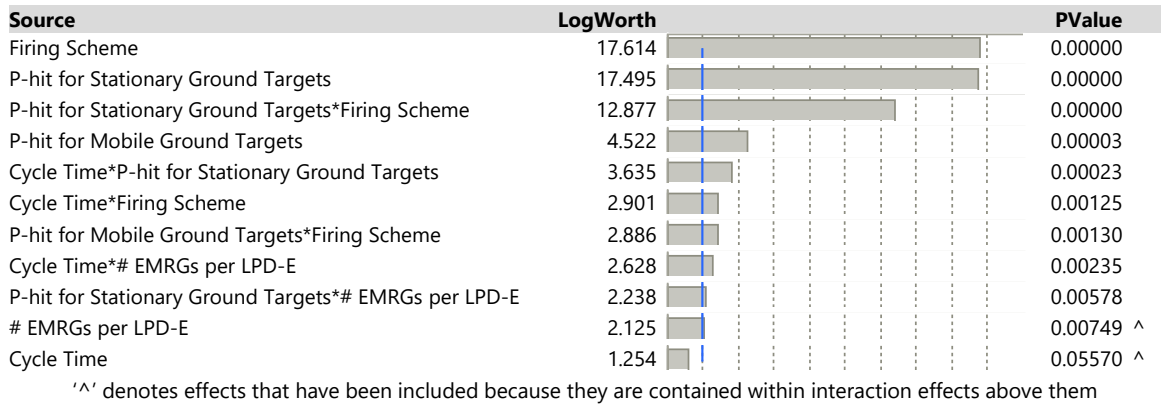

Figure 46. COA3 (High Enemy Concentration) Significant Factors for # ATF Ships Sunk

THIS PAGE INTENTIONALLY LEFT BLANK

LIST OF REFERENCES

- Beery, Paul, and Eugene Paulo. 2019. "Application of Model-Based Systems Engineering Concepts to Support Mission Engineering." *Systems* 7, no. 3: 44–58.
<https://doi.org/10.3390/systems7030044>.
- Bennett, Jay. 2016. "The Future of the Navy's Electromagnetic Railgun Could Be a Big Step Backwards." *Popular Mechanics*.
<https://www.popularmechanics.com/military/weapons/a21174/navy-electromagnetic-railgun/>.
- Berger, David H. 2019. "38th Commandant's Planning Guidance." <https://www.marines.mil/News/Publications/MCPEL/Electronic-Library-Display/Article/1907265/38th-commandants-planning-guidance/>. Quantico, VA: U.S. Marine Corps, July 17.
- Clark, Bryan. 2017. "Commanding the Seas, The U.S. Navy and the Future of Surface Warfare." Center for Strategic and Budgetary Assessments Online.
https://csbaonline.org/uploads/documents/CSBA6292-Surface_Warfare_REPRINT_WEB.pdf.
- Clark, Bryan, and Timothy A. Walton. 2019. "Taking Back the Seas—Transforming the U.S. Surface Fleet for Decision-Centric Warfare." Center for Strategic and Budgetary Assessments Online.
https://csbaonline.org/uploads/documents/Taking_Back_the_Seas_WEB.pdf
- Department of the Navy (DON). 2017. "Littoral Operations in a Contested Environment Unclassified Edition." <https://www.hsdl.org/?view&did=804776>. Washington, DC: Department of the Navy & Marine Corps.
- Duplessis, Brian. 2018. "Thunder from the Sea: Naval Surface Fire Support." *Fires*, May, 49–55.
- Giachetti, Ron. 2020. Systems Engineering Body of Knowledge—Mission Engineering. SEBOK. https://www.sebokwiki.org/wiki/Mission_Engineering.
- Joint Chiefs of Staff. 2019. *Joint Publication 3-02 Amphibious Operations*. Washington, DC: Department of Defense, Jan 04.
- MacCalman, Alex, Paul Beery, and Eugene Paulo. 2016. "A Systems Design Exploration Approach that Illuminates Tradespaces Using Statistical Experimental Designs." *Systems Engineering* 19, no. 5(September): 409–421.
<https://doi.org/10.1002/sys.21352>.
- Montgomery, Douglas C, and George C Runger. 2014. *Applied Statistics and Probability for Engineers* 6th ed. Hoboken, NJ: John Wiley and Sons.

- O'Rourke, Ronald. 2019. *Navy Lasers, Railgun, and Gun-Launched Guided Projectile: Background and Issues for Congress*. CRS Report No. R44175. Washington, DC: Congressional Research Service.
<https://crsreports.congress.gov/product/details?prodcode=R44175>.
- U.S. Marine Corps. 2017. "Marine Corps Functional Concept for Marine Air Ground Task Force Fires." Quantico, VA, September 28.
- U.S. Navy. n.d. The Amphibious Ready Group. Accessed February 2020.
<https://www.navy.mil/navydata/news/.www/arg.html>.
- . n.d. United States Navy Fact File - MK 45 5-Inch 54/62 Caliber Guns. Accessed 2020. https://www.navy.mil/navydata/fact_display.asp?cid=2100&tid=575&ct=2.
- . n.d. USS Missouri (BB 63). Accessed February 2020.
https://www.navy.mil/navydata/nav_legacy.asp?id=131.
- Vieira, Helcio. 2012. "NOB Mixed Design Worksheet."
<https://nps.edu/web/seed/software-downloads>.

INITIAL DISTRIBUTION LIST

1. Defense Technical Information Center
Ft. Belvoir, Virginia
2. Dudley Knox Library
Naval Postgraduate School
Monterey, California