

REPORT DOCUMENTATION PAGE

Form Approved
OMB No. 0704-0188

The public reporting burden for this collection of information is estimated to average 1 hour per response, including the time for reviewing instructions, searching existing data sources, gathering and maintaining the data needed, and completing and reviewing the collection of information. Send comments regarding this burden estimate or any other aspect of this collection of information, including suggestions for reducing the burden, to Department of Defense, Washington Headquarters Services, Directorate for Information Operations and Reports (0704-0188), 1215 Jefferson Davis Highway, Suite 1204, Arlington, VA 22202-4302. Respondents should be aware that notwithstanding any other provision of law, no person shall be subject to any penalty for failing to comply with a collection of information if it does not display a currently valid OMB control number. **PLEASE DO NOT RETURN YOUR FORM TO THE ABOVE ADDRESS.**

1. REPORT DATE 16 October 2020		2. REPORT TYPE Briefing Charts		3. DATES COVERED (From - To) 23 September 2020 - 30 October 2020	
4. TITLE AND SUBTITLE Advanced Power Electric Propulsion (APEP)				5a. CONTRACT NUMBER	
				5b. GRANT NUMBER	
				5c. PROGRAM ELEMENT NUMBER	
6. AUTHOR(S) Michael R Holmes, Stephanie Leathers				5d. PROJECT NUMBER	
				5e. TASK NUMBER	
				5f. WORK UNIT NUMBER Q18B	
7. PERFORMING ORGANIZATION NAME(S) AND ADDRESS(ES) Air Force Research Laboratory (AFMC) AFRL/RQRS 1 Ara Drive Edwards AFB, CA 93524-7013				8. PERFORMING ORGANIZATION REPORT NUMBER	
9. SPONSORING/MONITORING AGENCY NAME(S) AND ADDRESS(ES) Air Force Research Laboratory (AFMC) AFRL/RQR 5 Pollux Drive Edwards AFB, CA 93524-7048				10. SPONSOR/MONITOR'S ACRONYM(S) 11. SPONSOR/MONITOR'S REPORT NUMBER(S) AFRL-RQ-ED-VG-2020-208	
12. DISTRIBUTION/AVAILABILITY STATEMENT Distribution Statement A: Approved for Public Release; Distribution is Unlimited. PA Clearance Number: 20479; Clearance Date: 16 October 2020.					
13. SUPPLEMENTARY NOTES The U.S. Government is joint author of the work and has the right to use, modify, reproduce, release, perform, display, or disclose the work.					
14. ABSTRACT Viewgraph/Briefing Charts					
15. SUBJECT TERMS N/A					
16. SECURITY CLASSIFICATION OF:			17. LIMITATION OF ABSTRACT	18. NUMBER OF PAGES	19a. NAME OF RESPONSIBLE PERSON
a. REPORT	b. ABSTRACT	c. THIS PAGE			19b. TELEPHONE NUMBER (Include area code)
Unclassified	Unclassified	Unclassified	SAR	27	Stephanie Leathers N/A



Advanced Power Electric Propulsion (APEP)

Dr. Michael R Holmes, Senior Scientist

Stephanie Leathers, Project Engineer

Aerospace Systems

Advanced Power Electric Propulsion (APEP)

Problem:

Conventional in-space propulsion has reached the limit of chemical performance

- Large propellant mass fraction required for orbit transfers and plane changes because of chemical propulsions low Isp
- Delivered spacecraft mass is small
- Remaining propellant will not support many maneuvers with either a chemical or Electric Propulsion (EP) system

Solution:

Combine advanced power technologies with high efficiency EP to replace chemical upper stages

- Reduce propellant fraction and increase spacecraft mass by using high Isp EP
- Capitalize on new energy technology to increase power available to EP thrusters
- Increase acceleration by increasing EP power
- Increase EP efficiency by increasing EP power
- Increase thruster life by increasing EP power
- Increase transfer efficiency by using high thrust impulsive transfer strategies
- Increase mission life by delivering more propellant to mission orbit

APEP Description

- APEP system highlighted in blue box.
 - Lightweight PV systems approaching 200 W/kg
 - Battery systems approaching 250 Whr/kg
- Dramatically scale up power using lightweight energy dense PV arrays and batteries
- Higher power gives higher acceleration
- Higher acceleration enables impulsive EP maneuvers
- Impulsive EP increases orbit transfer efficiency
- Higher power EP systems more efficient, lower specific mass
- EP Systems provide longer mission life by conserving propellant for the mission

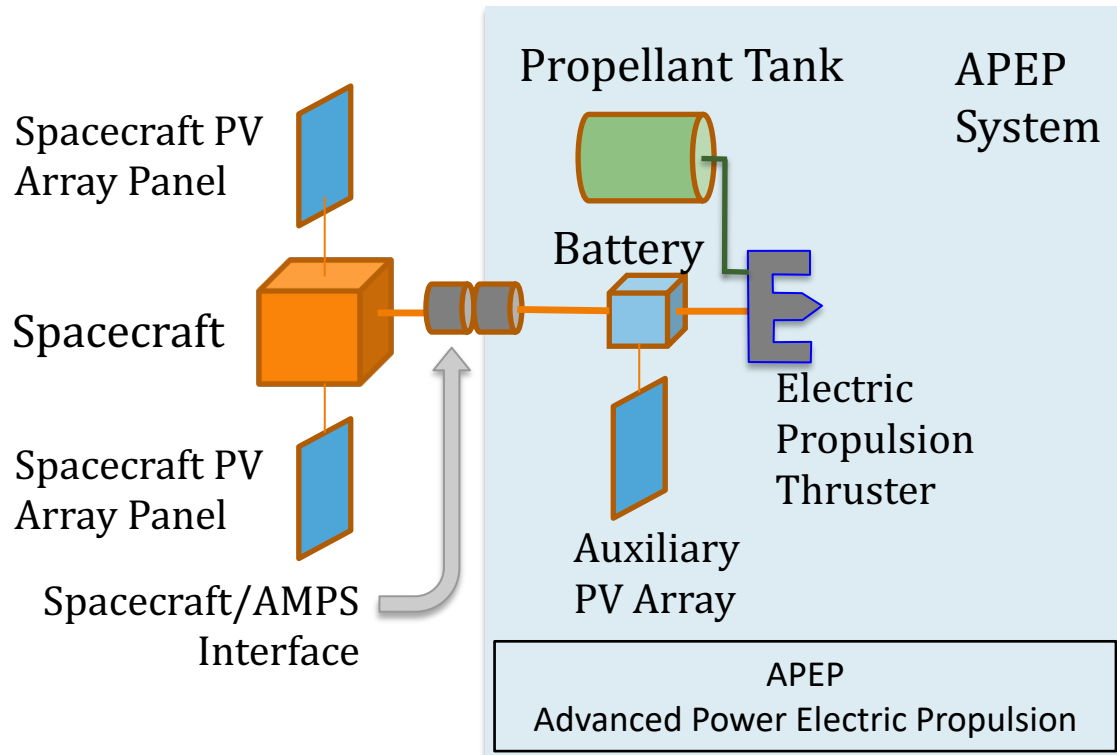

APEP Changes Upper Stage Architecture to Take Advantage of New Energy Technologies

APEP LEO to GEO Mission Comparison

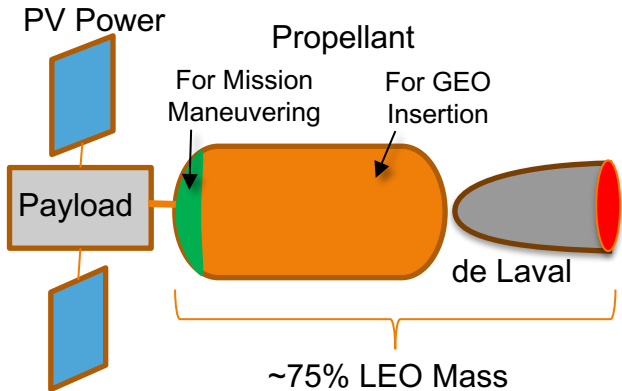

Conventional Chemical

- Hohmann transfer is efficient & fast
- Large propellant mass required
- PV designed for payload
- PV provides limited power for EP low thrust station-keeping
- Chemical is fast but propellant hog, short mission life
- Conventional propulsion at limit

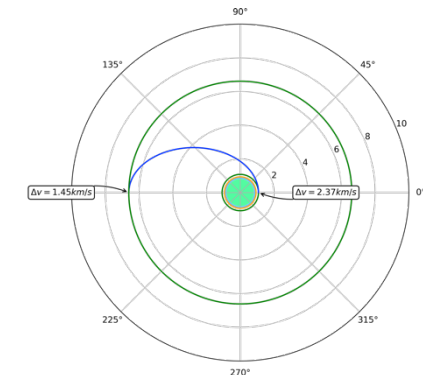

Hohmann Transfer

- Single LEO burn to transfer orbit
- Single Apogee burn to GEO

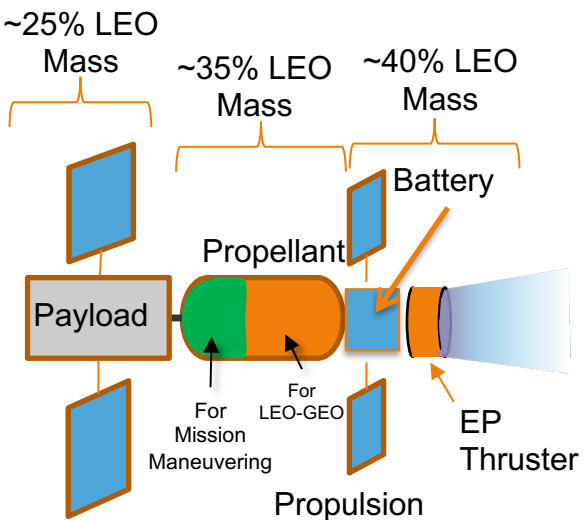

High Power Agile Electric Propulsion

- Replace chemical propulsion with higher Isp EP propulsion
- Less propellant mass required for transfer leaving more mass for payload and APEP system
- Multi-orbit Hohmann transfer more efficient than low thrust spiral
- New energy dense battery technology enables high thrust impulses using energy stored over an orbit
- Higher power EP is more efficient and specific mass is lower
- Greater overall agility and life at mission orbit

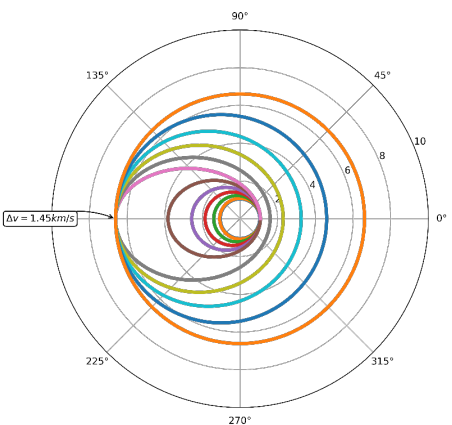

Multi-Orbit Hohmann Transfer

- Multiple LEO burns to transfer orbit
- Multiple Apogee burns to GEO

GEO Missions are Common, Good Choice for APEP Performance Comparison

APEP Anatomy of a Transfer

- Illustrative Example:
 - Circular LEO starting orbit
 - Circular GEO ending orbit
 - Many confocal elliptical trajectories shown
- Trajectory solution to Newton's 2nd Law
- Hohmann strategy with thrusting (colored red) centered about perigee (green trajectories) or apogee (blue trajectories)
- Battery 7% of full size ($\beta=0.07$) for clearer illustration of thrusting, charging, and coasting regions
- Gravity loss due to extended thrust interval calculated (large in this figure for $\beta=0.07$)
- Spacecraft coasts in Keplerian trajectories while not thrusting.
 - Battery charges in bright green or blue trajectories
 - Battery full in dark green or blue trajectories
- Solar panel energy is lost when battery is full, energy loss is calculated
- Calculated losses used to evaluate mission performance metrics

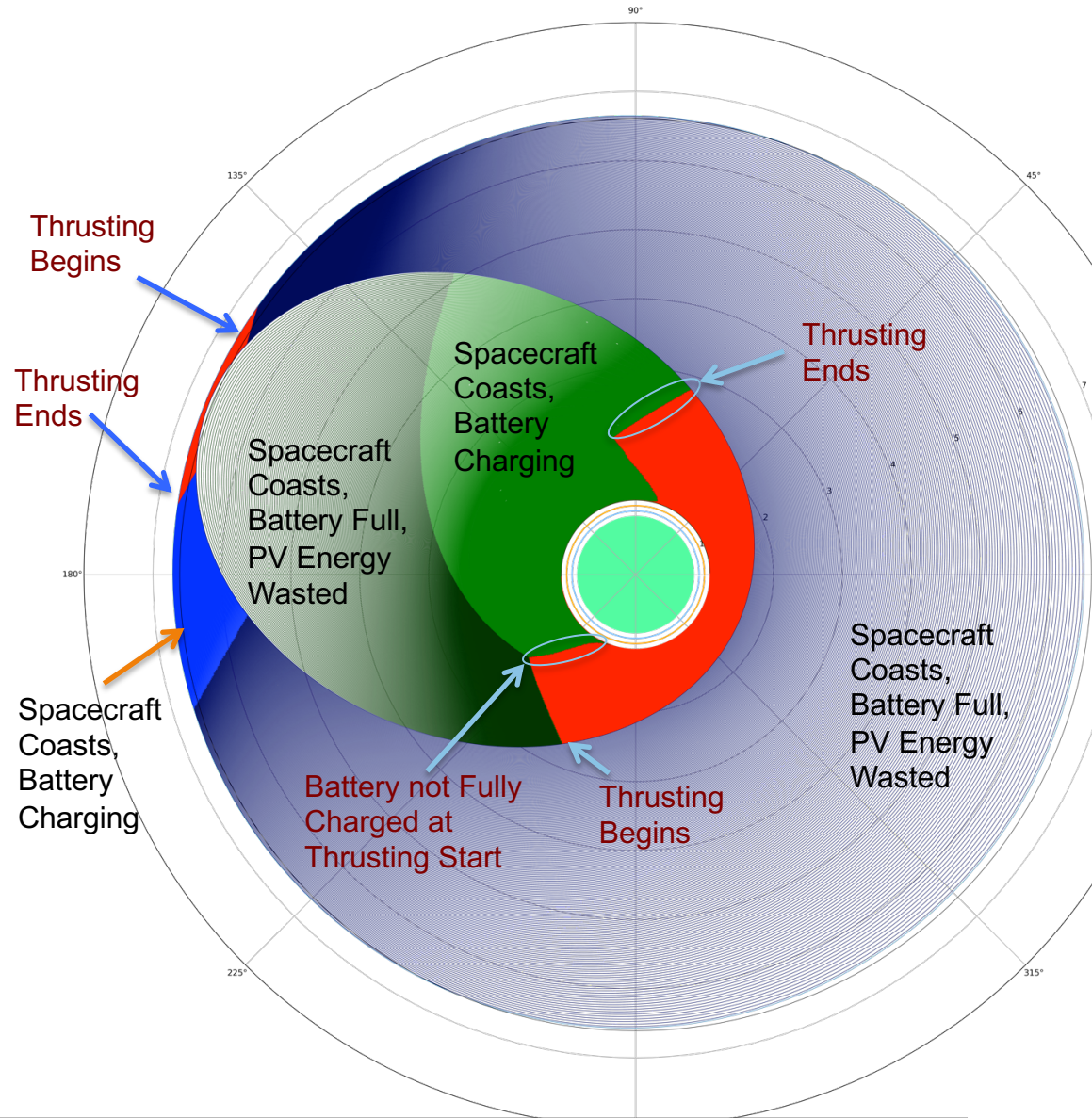

APEP 2020 Thruster & Power SOA

- Battery size is limited by specific power = 5 kWhr/kg for this example
 - To reduce dry mass, Battery is sized to collect and store only 40% of all solar PV energy in longest GEO orbit
 - Nearly 100% of PV energy stored in shorter orbits for perigee burns
- Time loss due to insufficient storage is about 15% making trip time comparable to equivalent low thrust spiral transfer
- Propellant loss due to insufficient storage is negligible making required propellant mass 15% less than for spiral transfer
- Gravity loss due to extended thrust arc is negligible for discharge rate of 0.5C

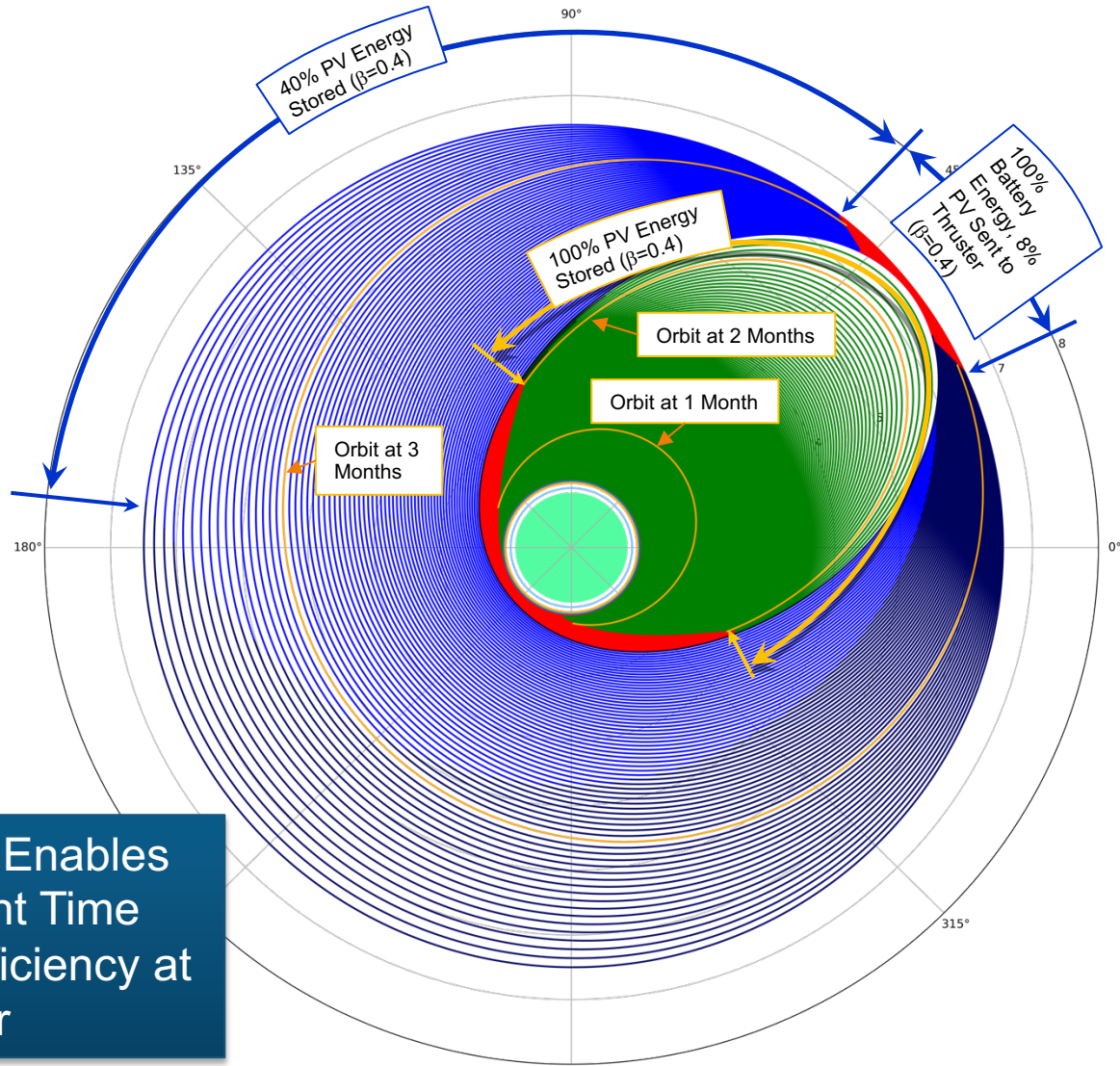

APEP Use of Energy Storage Enables Thrusting at the Most Efficient Time Taking Advantage of Higher Efficiency at Higher Thruster Power



APEP Future Performance

Future Thruster and Power Advances Will Enable 100% Energy Utilization and Reasonable Transfer Times Using EP

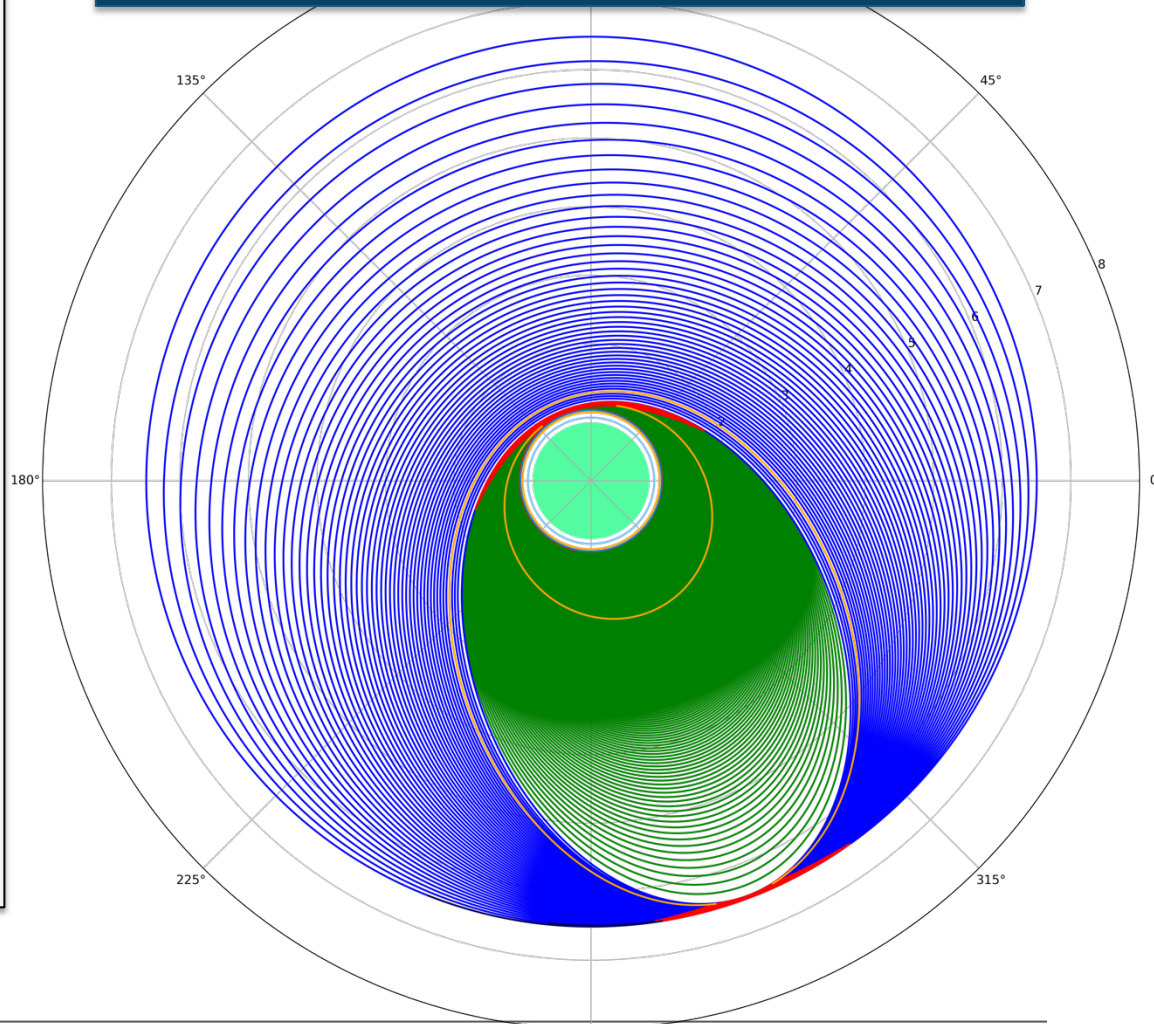
- Lighter Batteries would allow 100% power utilization ($\beta=1.0$)
- Transfer time is about 15% shorter than equivalent low thrust spiral transfer
- Propellant mass needed is about 15% less than for spiral transfer
- Gravity loss negligible as evidenced by overlapping burn arcs
 - Perigee does not increase significantly during perigee burns
 - Apogee does not increase significantly during apogee burns
 - 0.5C burns are sufficiently short
- As spacecraft climbs, period increases and depth of discharge of battery increases
 - First burn depth of discharge = 2.6%
 - Depth of discharge at 1 month = 55%
 - Last burn depth of discharge = 100%
- 100% PV usage can be achieved by,
 - Decreasing battery specific mass
 - Decreasing discharge rate (Reduces thruster size and mass)
 - Decreasing thruster specific mass
 - Optimizing thrust vector

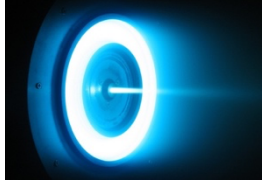
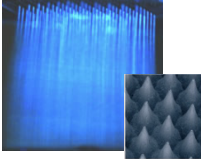

APEP Thruster Comparison

	Thrust Mechanism	Propellant	Max Isp, Min Thrust/Power	Min Isp, Max Thrust/Power	T R L	
Electro-thermal	Isentropic Expansion	Any Gas or Liquid	1100 s, 72mN/kW	200 s, 450 mN/kW	4	
Hall	Electric Field	Noble Gases, Some Metals	3000 s, 45 mN/kW	800 s, 90 mN/kW	6	
Electro-spray	Electric Field	Conductive Liquids	3000 s, 20 mN/kW (estimate)	1100 s, 90 mN/kW (estimate)	3	
Electro-magnetic	Electric and Magnetic Fields	Any Gas or Liquid	3000 s, 35 mN/kW (estimate)	500 s, 120 mN/kW (estimate)	3	

**Thrust/Power Important for Quick Maneuvering
Isp Important for High Delta-V**

APEP Thruster Concepts

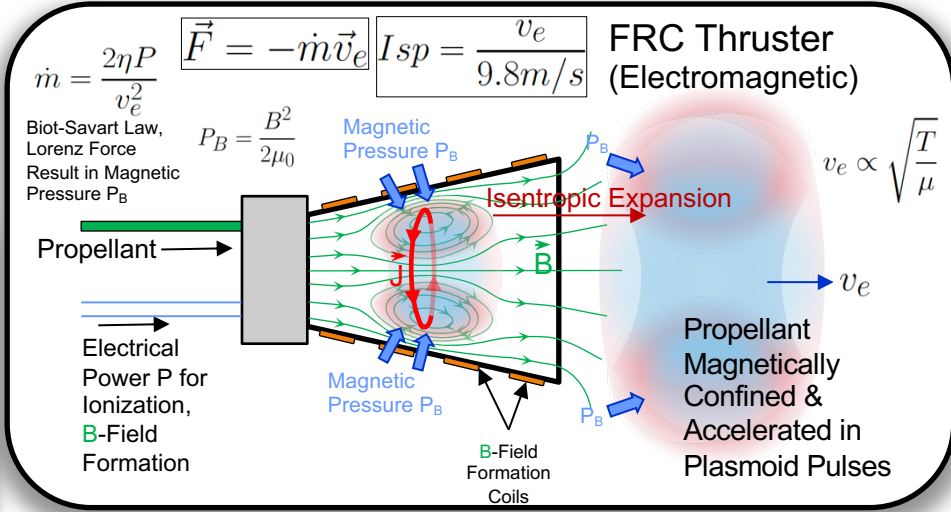
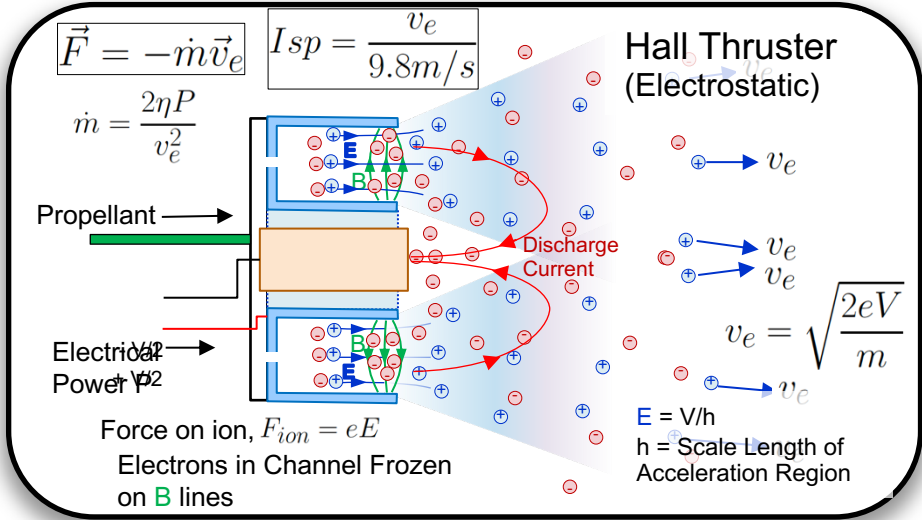
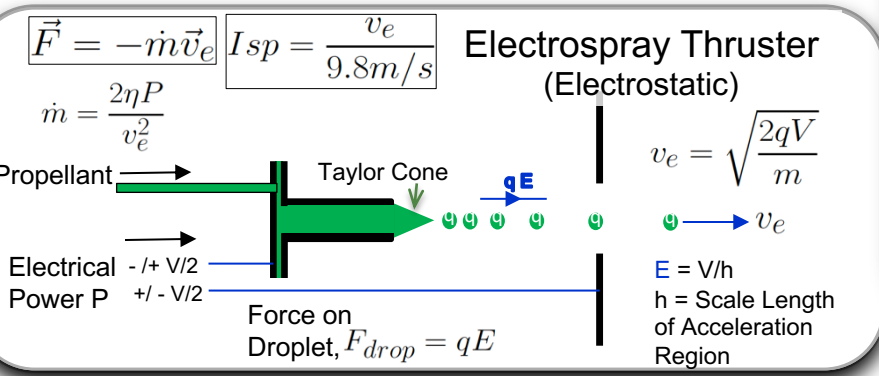
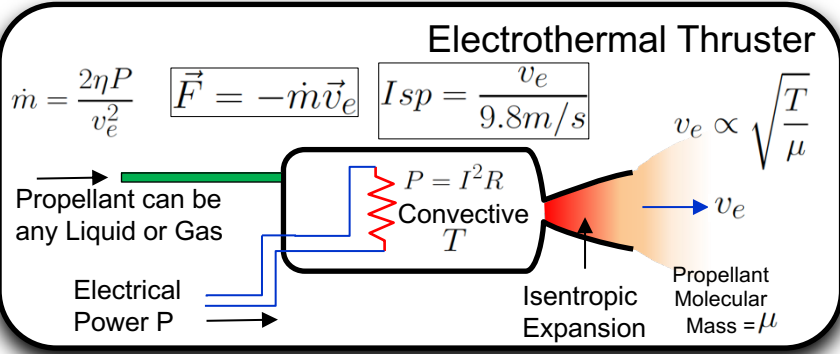
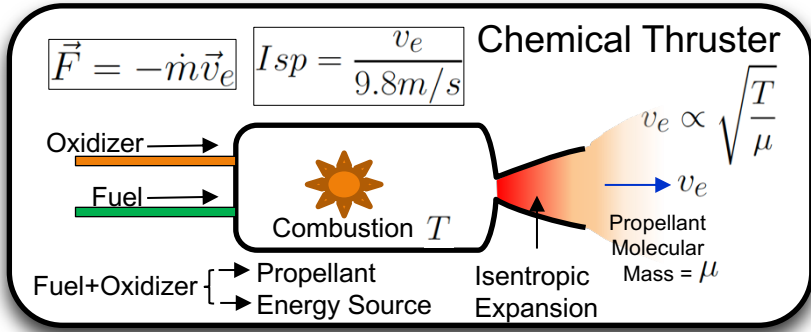

APEP Model Generation

- Four Metrics are used to characterize APEP performance
 - LEO-GEO trip time
 - Maximum acceleration at GEO mission orbit
 - Delta-V delivered with battery discharge
 - Total Delta-V available after LEO-GEO transfer
- Trajectories calculated for a matrix of battery sizes and Isp, metric performance is plotted as symbols
 - Integration of Newton's 2nd Law
 - Thruster efficiency is constant 62%
 - Spacecraft mass is 25% of LEO wet mass
 - Solar PV panel is 2 Watts per kg of LEO wet mass
 - 0.5C discharge rate is easy for Li-ion batteries and high enough for efficient transfer
- An APEP Model is fit to trajectory integration symbols and plotted as curves
 - Includes gravity loss model for non-impulsive burns
 - Includes loss model for undersized battery
 - Includes specific masses of power and thruster technologies
 - Different transfer maneuvers will require recalculating fit
- Graphs like those at right are used to validate APEP Model over a wide range of thruster and power parameters
- APEP Model is then used to evaluate the performance of specific thruster and power technologies

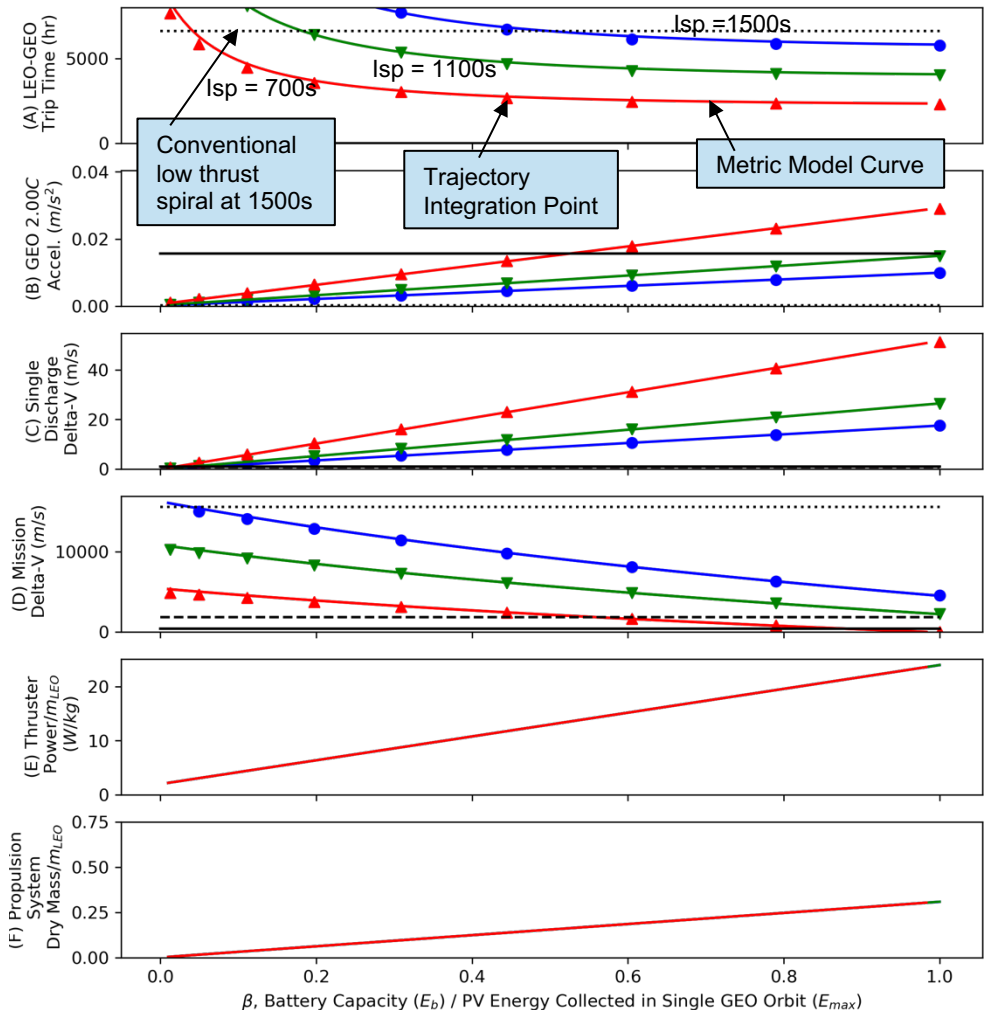

APEP Performance Calculations are Based on Newton's Law Integration

APEP Thruster Technologies

- Thrust to Power Ratio T/P:
 - High T/P reduces trip time
 - Proportional to efficiency
 - Inversely Proportional to Isp
 - High efficiency over a wide Isp range is desirable to provide maximum propulsion flexibility
- T/P curves are thruster model fits to Hall, Electro spray, Electrothermal performance data points
- Electromagnetic performance expected close to Electro spray curve
- T/P thruster models used in APEP Model to calculate and compare APEP performance on 4 metrics

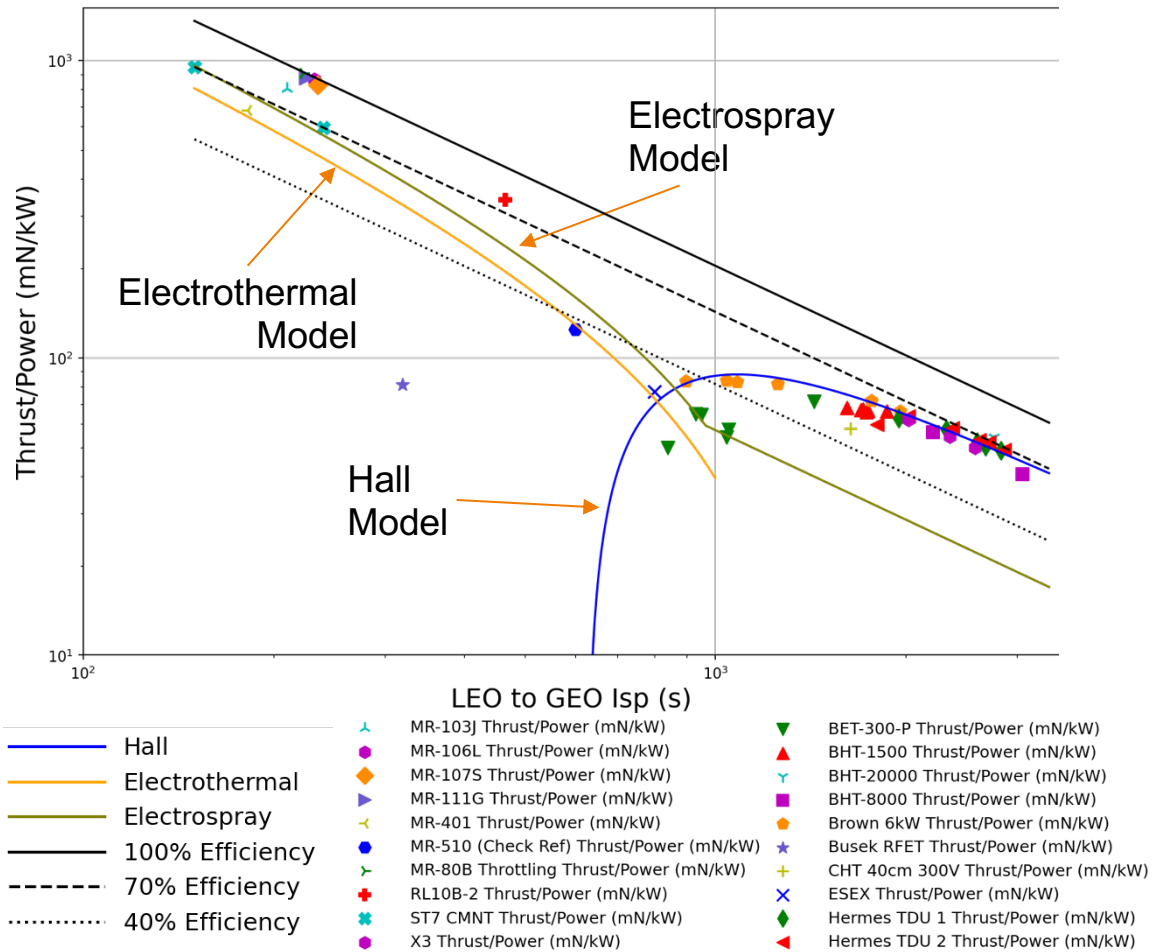

APEP Performance Calculations Include Historical EP Thruster Performance Data

APEP Metric: Acceleration

- T/P thruster models are combined with APEP Model to calculate acceleration as a function of Isp
- Chemical curve shown for comparison
- Hall thrusters give highest acceleration for Isp > 900s because of high efficiency of mature Hall technology
- Electro spray in droplet mode provides highest acceleration for Isp < 900s because of anticipated high efficiency
- Electrothermal acceleration is slightly less than electro spray because of lower efficiency
- Electromagnetic not shown because of lack of data, curve expected to be between electro spray and electrothermal
- Low thrust Hall refers to a conventional architecture where power is limited to spacecraft PV power

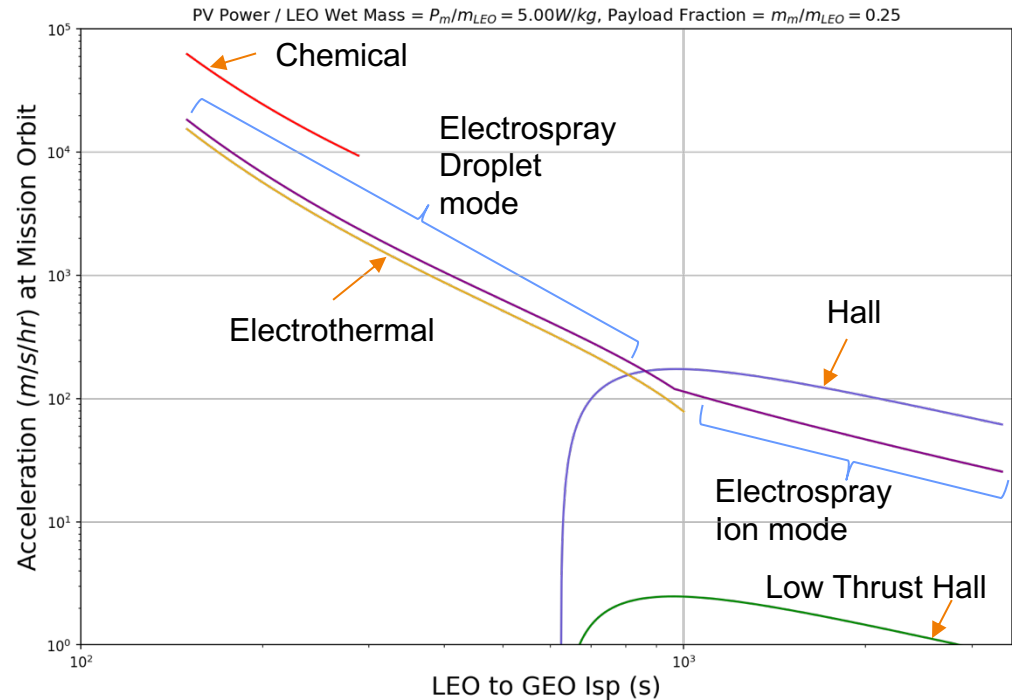

APEP Acceleration Much Higher Than Conventional Hall Thruster Implementations and Approaches Chemical Performance

APEP Metric: Delta-V at Mission Orbit

- T/P thruster models are combined with APEP Model to calculate Delta-V as a function of Isp
- For electrothermal, electro spray, and Hall thrusters, top curve is for using highest Isp at mission orbit, middle curve is for mission Isp = LEO-GEO Isp, bottom curve is Delta-V available from full battery discharge.
- Propellant available for mission balanced with battery and thruster size (battery sized to 40% of optimal for these curves)
- Impulsive Hohmann approach reduces propellant requirement and offsets much of Battery mass
- All EP thruster types outperform chemical by at least an order of magnitude
- Hall thruster performance is lower than electro spray because electro spray thruster mass is assumed lower

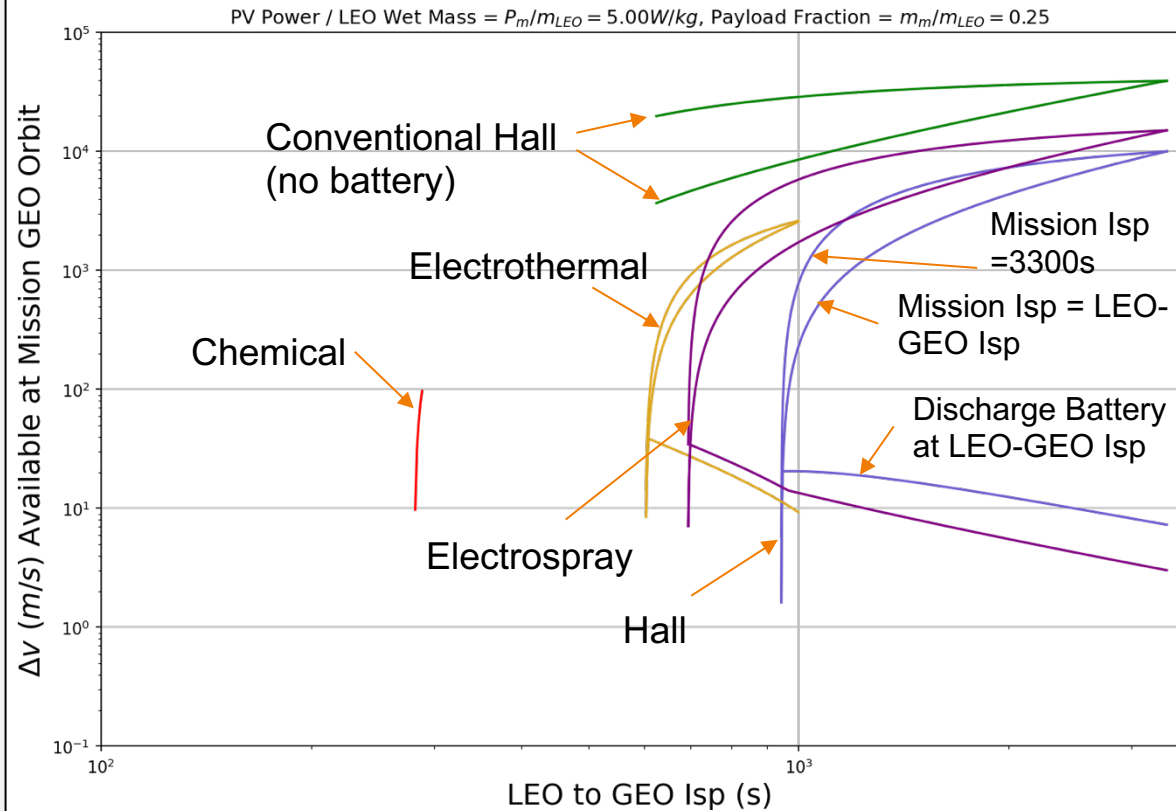

All APEP Thruster Implementations Give Much Higher Delta-V Performance Than Chemical

APEP Metric: LEO to GEO Trip Time

- T/P thruster models are combined with APEP Model to calculate trip time
- Historically, trip times greater than 100 days have been unacceptable to customers
- Curves are truncated for low Isp where propellant mass insufficient for transfer
- Hall thrusters much quicker than electrospays above 1000s because of high Hall efficiency
- Conventional Hall slightly faster than APEP Hall
 - Battery size limited to 40% of optimal because of mass
 - LEO-GEO Delta-V requirement still 15% less than low thrust Hall
- Hall Isp between 1000s and 1200s is attractive option given the high Delta-V in this range (see previous slide)
- Electrothermal, Electrospay, Electromagnetic thrusters perform well between 600s and 800s

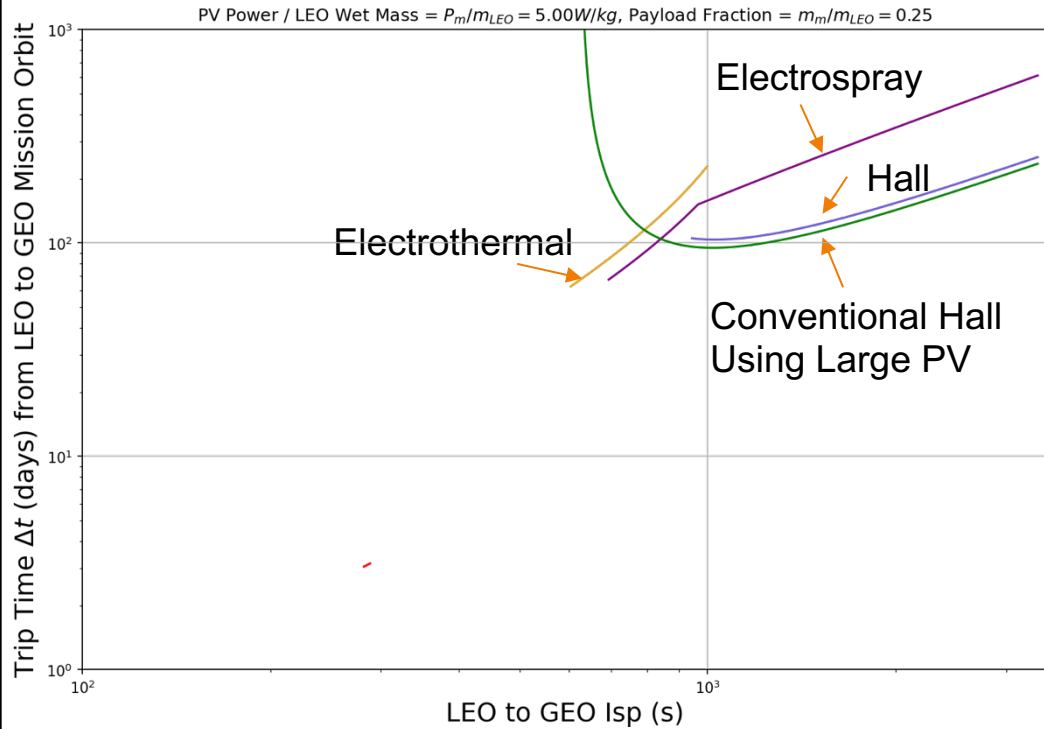

Trip Time With APEP SOA Power Technology is About 4x Faster Than Conventional EP Transfers at Lower Power

APEP Adding PV Power

- T/P thruster models are combined with APEP Model to calculate trip time
- All curves are for a Hall thruster based APEP system
- Battery size is decreased as Aux power increased to maintain thruster power and system mass
- Acceleration also decreases slightly with additional aux. power because battery size reduced
- Trip time can be reduced by adding auxiliary PV array

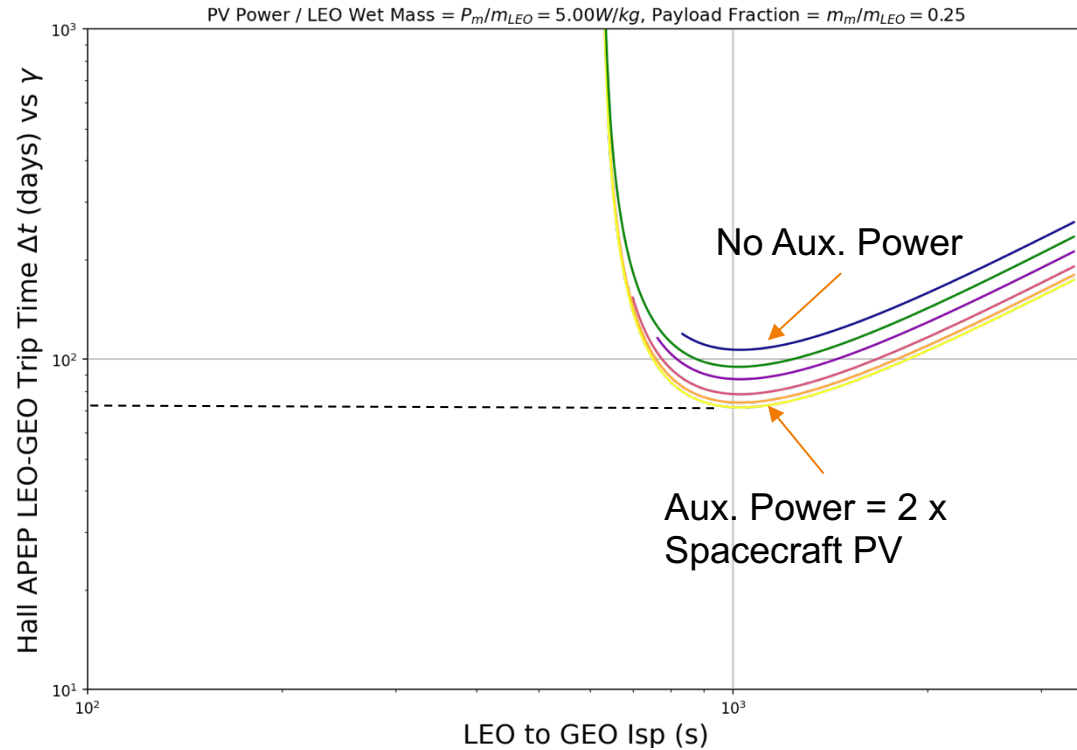

Trip Time Reduced Further by Using Propulsion-Specific PV Power

APEP Battery Specific Mass

- Curves are for Hall based APEP (except for red chemical curve and green low thrust Hall)
- Terrestrial Li-Ion SOA ~ 5kg/kWhr (200W/kg)
- Thruster specific mass = 2.0kg/kW
- Reducing battery mass increases propellant mass and mission Delta-V
- Battery size is only 40% of optimal for trip time
- Future improvements in energy density can be used to increase delta-V, decrease trip time, or both

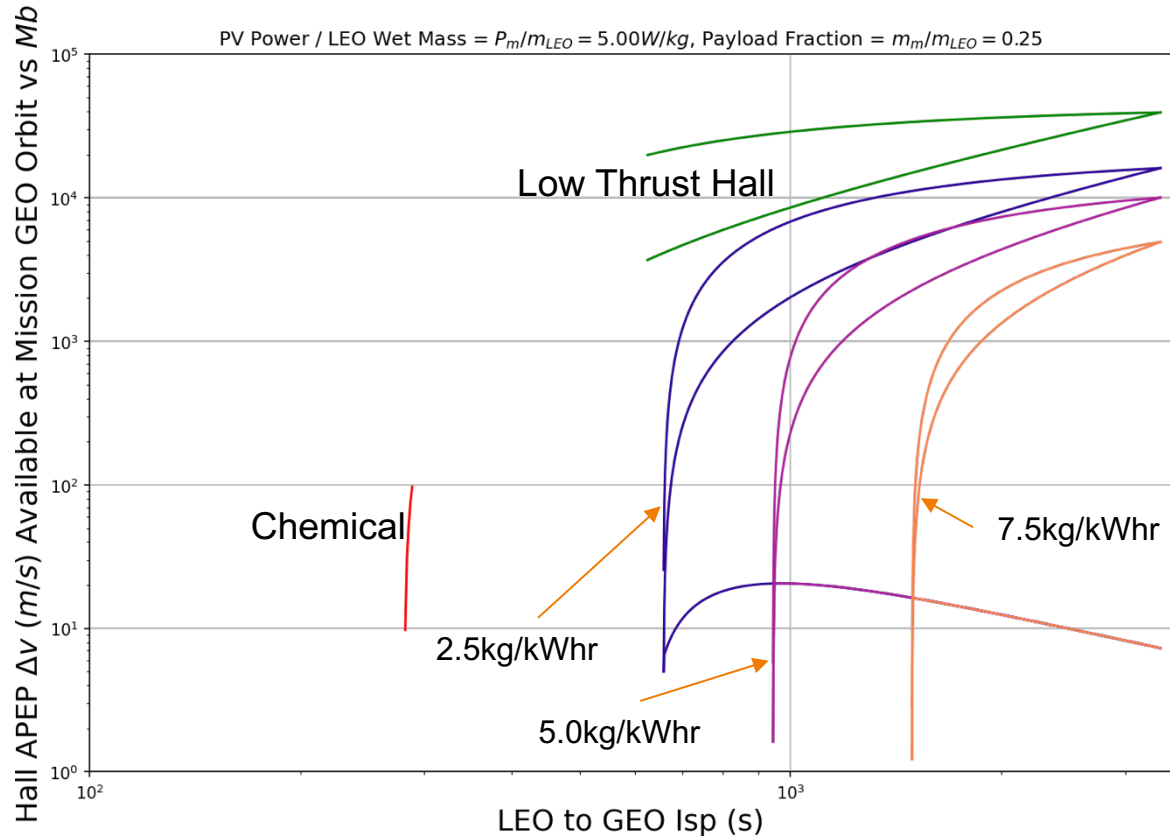

Delta-V Increased, Trip Time Reduced by Future Battery Mass Reduction

APEP Thruster Specific Mass

- Curves are for Hall based APEP (except for red chemical curve and green low thrust Hall)
- Battery specific mass is 5kg/kW (200W/kg)
- Less massive thrusters leave more room for propellant and mission Delta-V is increased
- Reducing thruster specific mass allows for excellent Delta-V at 1000s where trip time is at a minimum (2 slides previous)

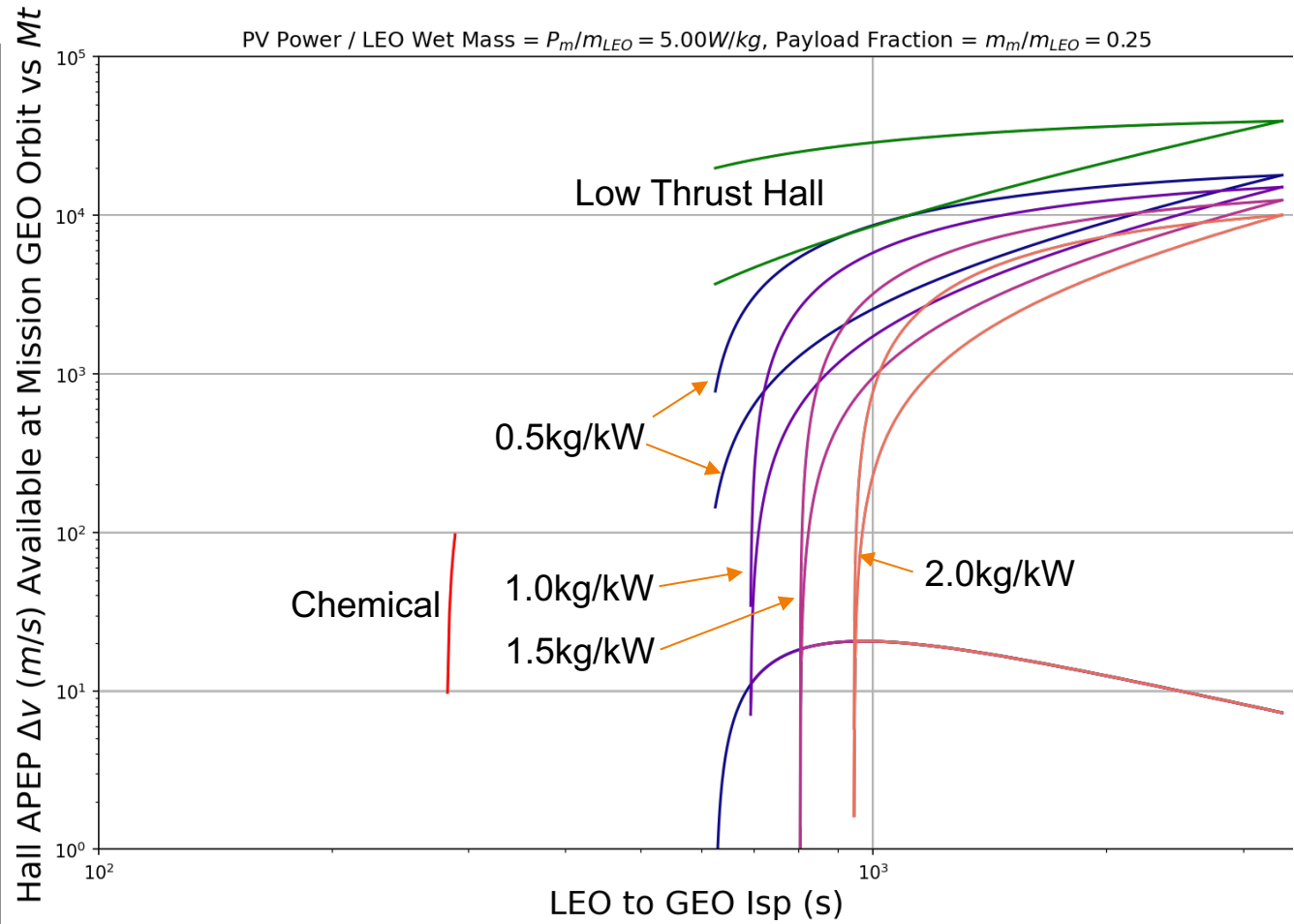

Delta-V Increased, Trip Time Reduced by Thruster Mass Reduction

APEP EP Technology Limits

- **Hall thrusters: good overall performance for power > 5kW on xenon**

- Thruster power for highest efficiency is greater than about 5kW
- Efficiency at 200W is about 20% lower than efficiency at 10kW
- Propellant is constrained to noble gases for high efficiency
- Hall thrusters running on chemical propellants would have very low efficiency
- Mass is relatively high because of need for dense materials to generate magnetic fields
- Specific mass trends lower for increasing thruster power
- APEP analysis operates thruster at higher power than needed for LEO-GEO transfer; this is an advantage for transfer trip time because Hall thrusters have higher efficiency and T/P when operated at lower power and low Isp
- **Development needed:** Lower specific mass and higher efficiency at low Isp

- **Electrothermal thrusters: good trip time and acceleration for power > 5kW on any propellant, Delta-V capability is sufficient**

- Thruster power for highest efficiency is greater than about 10kW (nozzle and radiation losses smaller at high power)
- Efficiency at 1kW is anticipated about 50% lower than efficiency at 10kW
- Any propellant can be used for most electrothermal concepts, good for MMP
- Electrothermal thrusters running on chemical propellants is expected to have similar efficiency characteristic to conventional chemical thrusters
- Mass is relatively low because magnetic fields are small or not required
- Specific mass anticipated to trend lower for increasing thruster power
- **Development needed:** >10kW power thruster development at 600 to 1000s Isp

Hall Thrusters and Electrothermal Thrusters are
Excellent and Complementary APEP Candidates

APEP EP Technology Limits

- **Electrospray thrusters: good overall performance at very low power**

- Highest thruster power tested is only a few watts, not useful for payloads greater than a few kg mass
- Efficiency appears to be flat over different power levels, greater in droplet mode, lower in ion mode
- Wide operational Isp range allows high acceleration and Delta-V by changing mode in flight
- Propellant is constrained to ionic liquids but these could be energetic ionic liquids for MMP
- Specific Mass is unknown but possibly lower than that of Hall thrusters because of no need for magnetic fields
- Specific mass trend is unknown
- Lifetime is unknown
- **Development needed:** Higher efficiency in ion mode, demonstration of long lifetime, and scale-up to much higher powers

- **Electromagnetic thrusters: good trip time, Delta-V, and acceleration for power > 20kW on any propellant, however, relatively unproven**

- Thruster power for highest efficiency is greater than about 20kW (ionization and plasma magnetization energy thresholds)
- Efficiency below 20kW expected to be a few percent
- Any propellant can be used because of minimal propellant contact with thruster components
- Electromagnetic thrusters running on chemical propellants would have similar efficiency characteristic to conventional chemical thrusters because thrust is generated by isentropic expansion of plasmoid magnetic structures
- Mass is relatively low because magnetic fields are generated by lightweight conductors
- Specific mass anticipated to trend lower for increasing thruster power
- Electromagnetic thrusters have not had sufficient development though performance predictions are informed by the fusion research community which uses many plasma acceleration devices
- **Development needed:** > 20kW power, much more testing with different propellants and over a range of Isp

Electrospray and Electromagnetic Propulsion Concepts Could Outperform Hall and Electrothermal With Additional Development

APEP Conclusions

- Results consistent with previous mission analysis
 - High Isp means longer mission life and higher total Delta-V
 - High efficiency and T/P gives faster trip times
- Energy storage allows for a big step-up in thruster power which results in several advantages
 - Time and propellant mass savings by using multi-Hohmann transfer (15% for LEO-GEO, ~25% with plane change)
 - Efficiency increase from scaling to higher power (0% for big spacecraft, 20% for small)
 - Thruster lifetime constraints lessened because bigger thruster will operate for less time for a given Delta-V (on order of 10x reduction of firing time)
 - Tens of m/s Delta-V on short notice with 15 minutes of thrust (Energy storage gives option for 100x rapid acceleration over conventional EP)
- Hall thruster performance at higher T/P for lower power is good fit to the APEP concept
 - Operation at lower power 0.5C discharge for LEO to GEO allows for operating thruster at highest T/P to minimize trip time
 - Operation at battery discharge limit (>2C) at mission orbit to increase acceleration and conserve propellant
- Greater spacecraft mass and Delta-V capability delivered to destination orbit than with chemical
 - Larger Delta-V missions give larger advantage
 - Also true for plane changes
- APEP could carry a small chemical thruster system for use at a destination orbit
 - Enable very high acceleration for emergency situations
 - Chemical's low Isp is less of an issue if not needed for large orbit maneuvers for insertion
- Trip time between initial and final orbit is the biggest concern for APEP
 - Current technology can perform LEO-GEO transfer in about 100 days
 - Near term technology development and improvements will bring trip time down to around 80 days
 - Future reduction of energy storage mass, PV array mass, thruster mass will decrease trip time and increase Delta-V capability
- Modest improvements in PV, Battery, and thruster technologies will improve performance significantly
- Results point to specific EP development priorities

Emerging Power Tech., Lower Mass, Higher Efficiency can
Increase Spacecraft Delta-V and Agility Greatly

APEP Development Priorities

1. Push development of high T/P Hall thrusters operating at low Isp (1-5 years)
 - Decreases trip time, increases acceleration
2. Decrease Hall thruster specific mass
 - Decreases trip time, increases acceleration, increases Delta-V
3. Develop electrothermal thrusters at powers greater than 10kW to overcome nozzle losses (1-5 years)
 - Decreases trip time, increases acceleration
4. Decrease energy storage specific mass
 - Decreases trip time, increases acceleration, increases Delta-V
5. Push dramatic power scale-up of electrospray thrusters (5-10 years)
 - Decreases trip time, increases acceleration, increases Delta-V
6. Develop high efficiency droplet mode electrospray thrusters (5-10 years)
 - Decreases trip time, increases acceleration
7. Develop dual mode electrospray thruster that can operate in either droplet or ion mode at high power (5-20 years)
 - Decreases trip time, increases acceleration, increases Delta-V
8. Develop electromagnetic propulsion concepts (10-20 years)
 - Decreases trip time, increases acceleration, increases Delta-V

**Note: Development time estimates based
on development start time of today**

Questions?

APEP Backup Slides

APEP Missions, Current Propulsion Options

Missions and Options		
Mission	Explanation	Likely Best Propulsion Option
Change rise time	Catch adversary in the open	Chemical for shift in single orbit Electrothermal, Electromagnetic
Continually shift spacecraft orbit	Deny predictability to adversary; Avoid overflight	Electrostatic or Electromagnetic Chemical if >10-min shift within single orbit required
Maintain orbits at low altitude against drag	Get closer to the ground for better observation	Electrothermal or Electromagnetic
Maintain non-Keplerian orbit	Maintain parallel path to asset or adversary (Hovering orbit) for observation or blocking view	Ion, Electrostatic, or Electromagnetic
Avoid Collisions	Rapid change in orbit to avoid collision; return when done	Chemical for shift; EP to return
Maneuver to New Orbit	Move spacecraft from insertion orbit to desired orbit	EP in most cases; Chemical or combination of Chemical and EP to transition radiation belts quickly

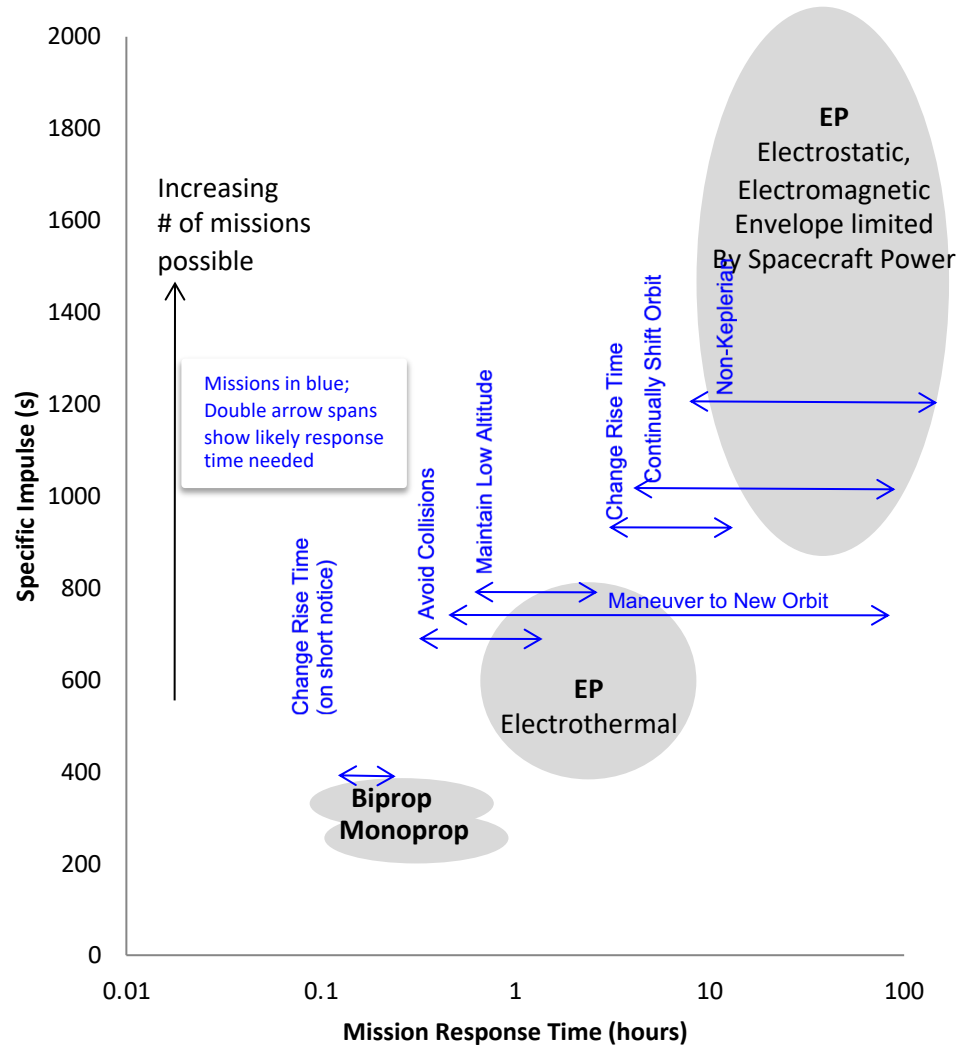

APEP Missions & Near Term Payoff

- Combining Hall or Ion thruster technology with battery expands envelope to cover much of mission space.
- Technical Barriers are minimal, Hall technology is TRL 6+.

Lightweight Energy Storage and Photovoltaics expand EP envelope

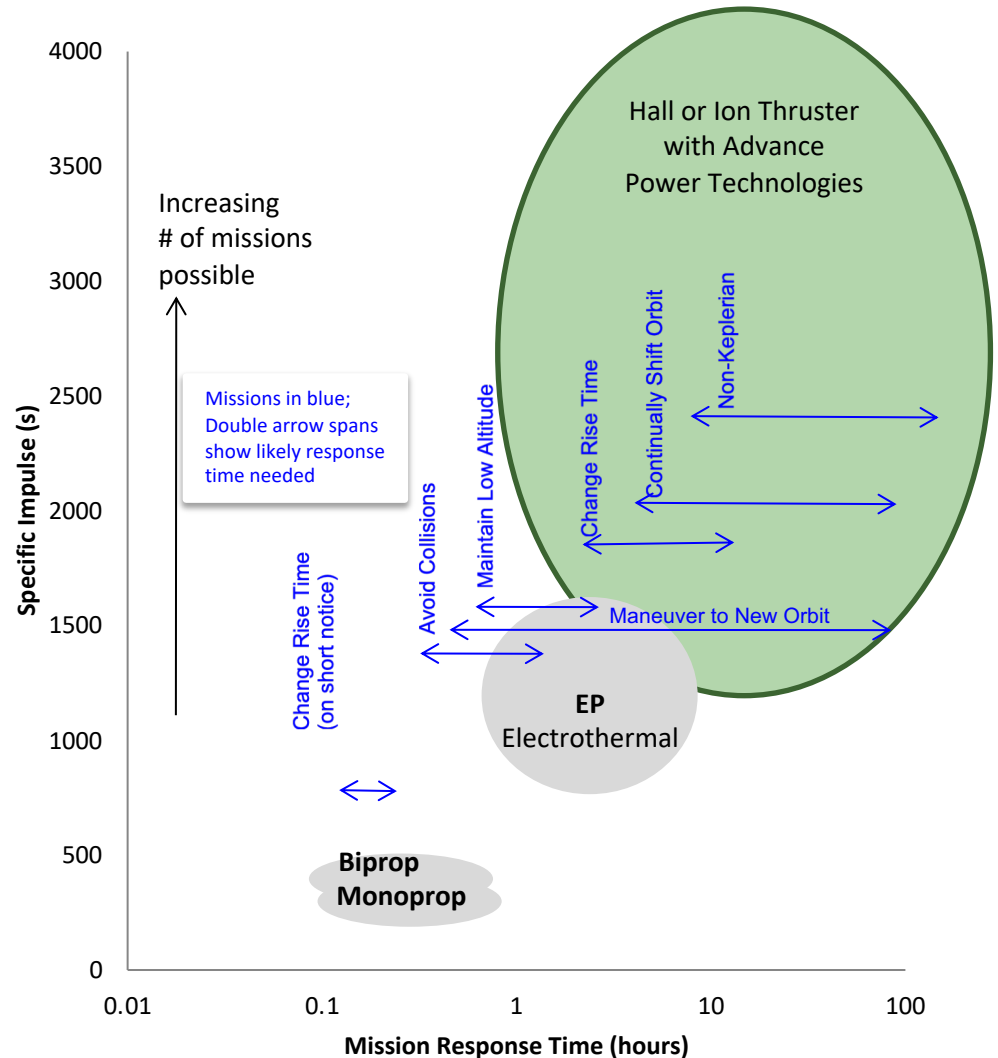

APEP Electrothermal, Electrospray, Electromagnetic

- Combining Electrothermal, Electrospray, or Electromagnetic thruster technology with Advanced Power expands envelope further.
- Common propellant allows chemical mode in addition to EP mode.
- Mission Space nearly covered with these propulsion options.
- Electrothermal is lowest risk technology and could be implemented soonest.
- Electrospray TRL is ~3 for very low thrust modules.
- Electromagnetic TRL is ~3 for high power concept, which is a good match for battery powered systems.
- Electric Thruster performance for chemical propellants is still an unknown for Electrosprays and Electromagnetic concepts.

APEP with future EP technologies maximizes Mission Space coverage

