



DEPARTMENT OF THE NAVY
OFFICE OF COUNSEL
NAVAL UNDERSEA WARFARE CENTER DIVISION
1176 HOWELL STREET NEWPORT RI 02841-1708

IN REPLY REFER TO

Attorney Docket No. 112564
21 April 2021

The below identified patent application is available for licensing. Requests for information should be addressed to:

TECHNOLOGY PARTNERSHIP OFFICE
NAVAL UNDERSEA WARFARE CENTER
1176 HOWELL ST.
CODE 00T2, BLDG. 102T
NEWPORT, RI 02841

Serial Number 17/089,811
Filing Date 5 November 2020
Inventor Thomas J. Gieseke

Address any questions concerning this matter to the Technology Partnership Office at (401) 832-3339.

DISTRIBUTION STATEMENT
Approved for Public Release
Distribution is unlimited

RAYLEIGH WAVE ELECTROMAGNETIC PUMP

STATEMENT OF GOVERNMENT INTEREST

[0001] The invention described herein may be manufactured and used by or for the Government of the United States of America for governmental purposes without the payment of any royalties thereon or therefor.

CROSS REFERENCE TO OTHER PATENT APPLICATIONS

[0002] None.

BACKGROUND OF THE INVENTION

(1) Field of the Invention

[0003] The present invention relates to a fluid pump, and more particularly to a peristaltic pump.

(2) Description of the Prior Art

[0004] Within the much larger field of fluid pumps is a class of pumps that employ mechanical pinching of flexible tubing to move fluid through the tube. Termed peristaltic pumps, these pumps are commonly used to move fluids that require isolation from the mechanisms of pumping because those fluids are toxic, corrosive, or are subject to contamination or damage by pumping equipment.

[0005] Although biological peristaltic pumps, such as the human digestive system, are mechanically simple, the mechanical analogues are typically complex. The associated mechanical equipment necessary to drive these pumps is large and involves a variety of sliding or rolling cams and pistons. Other designs involve pneumatic systems that employ a multitude of pistons to create the peristaltic effect on a tube. These systems are prone to wear and mechanical failure. These systems are also heavy and costly. Electromagnetic linear actuators are well known. These devices can be employed in peristaltic pumps in place of pneumatic actuators or rollers.

[0006] Electromagnets can be used to apply body forces to ferromagnetic materials over short distances. Movement of those materials under the action of the electromagnetic forces can be employed to perform work.

[0007] A related technology is ferro-fluids. Ferro-fluids are a suspension of magnetic or ferromagnetic particles in a fluid. Typically, the suspension fluid is an oil with low surface tension. These ferro-fluids respond to magnetic fields by deforming in a response to the local magnetic field lines. A similar effect can be achieved by suspending ferromagnetic or magnetic particles in an elastic material such as rubber. Flexible magnets used in self-adhesive automobile signage and refrigerator magnets are constructed of magnetic particles

suspended in a rubber polymer matrix binder. The concept can be applied to a wide range of particles and matrix binders. Various ratios of particle to matrix binders can be used to realize desired material properties, including permeability, Young's Modulus, and density.

[0008] Travelling surface waves in solids have various forms. These wave types include body compression waves, where particle motion is in the direction of wave travel, body shear waves, where particle motion is perpendicular to wave travel, and Raleigh waves, which is a propagating surface undulation wave. A similarity exists in the characteristics of a Raleigh wave and the peristaltic wave associated with peristaltic pumps.

[0009] It is known in the prior art that a peristaltic pump can be formed employing an array of electromagnets to apply a constrictive force on a tube that has imbedded magnetic materials. In the prior art, constriction is applied through repulsive forces of electro magnets acting on materials of the tube. For the necessary repulsive forces to be realized, as described in the prior art, the imbedded material must have magnetic properties with the polarity aligned to oppose the external applied magnetic field, must be a diamagnetic material, or must include electrical conductors and a current on which to be acted upon by the externally imposed magnetic field.

[0010] A superior apparatus is needed with reduced mechanical complexity for improved reliability.

SUMMARY OF THE INVENTION

[0011] It is therefore an object of the present invention to provide a peristaltic fluid pump. Other objects and advantages of the present invention will be apparent from the ensuing description.

[0012] Thus, the present invention is directed to a pump employing electromagnetically generated Rayleigh waves in an elastomeric structure with embedded ferromagnetic materials to create a peristaltic pumping action. The first embodiment of the present invention includes a frame having a base and two side walls defining a channel. The base has a plurality of apertures extending therethrough from a bottom surface of the base to the channel at a top surface of the base. A backing plate is joined to the frame side walls and defines a top of the channel. A composite elastomeric material is disposed in the channel at the base. The composite elastomeric material has an elastomeric matrix binder with ferromagnetic particles disposed in the binder. Electromagnets are provided in each frame aperture and positioned to interact electromagnetically with the composite elastomeric material. A controller is joined electrically to

each of the electromagnets. The controller is capable of independently activating each electromagnet.

[0013] It is therefore a general purpose and primary object of the present invention to provide a pump employing electromagnetically generated Rayleigh waves in an elastomeric structure with embedded ferromagnetic materials. Motion of these waves along one surface of a closed channel create a squeezing effect on a tube contained within this channel, thus forcing fluid along the tube length.

BRIEF DESCRIPTION OF THE DRAWINGS

[0014] A more complete understanding of the invention and many of the attendant advantages thereto will be readily appreciated as the same becomes better understood by reference to the following detailed description when considered in conjunction with the accompanying drawings wherein:

[0015] **FIG. 1** depicts a partially cut-away perspective view of a first embodiment of the invention;

[0016] **FIG. 2** depicts a longitudinal cross-sectional view of a first embodiment of the invention;

[0017] **FIG. 3** depicts a lateral cross-sectional view of a first embodiment of the invention in an undeformed state;

[0018] **FIG. 4** depicts a longitudinal cross-sectional view of a first embodiment of the invention in a first deformed state;

[0019] **FIG. 5** depicts a lateral cross-sectional view of a first embodiment of the invention in a first deformed state at a first longitudinal location;

[0020] **FIG. 6** depicts a lateral cross-sectional view of a first embodiment of the invention in a first deformed state at a second longitudinal location;

[0021] **FIG. 7** depicts a longitudinal cross-sectional view of a first embodiment of the invention in a second deformed state;

[0022] **FIG. 8** depicts a first embodiment of the invention with the tube clamping mechanism open and a tubing prepared for insertion in a perspective view; and

[0023] **FIG. 9** depicts a lateral cross-sectional view of a second embodiment of the invention in an undeformed state.

DETAILED DESCRIPTION OF THE INVENTION

[0024] **FIG. 1** depicts a pump system **10** in an isometric view. A flexible tube **100** is clamped between a curved backing plate **20** and a composite material **30**.

[0025] Electromagnetic fields do not impart forces on non-ferromagnetic materials, such as synthetic and natural rubbers, unless those materials are modified or augmented. Once such modification is to suspend ferromagnetic particles into those materials during their manufacture.

[0026] As depicted in **FIG. 1**, the composite material **30**, termed a ferromagnetic particle infused elastomer, can be an elastomeric material **32**, acting as a matrix binder, with ferromagnetic particles **34** suspended in the elastomeric material. Elastomeric materials include natural rubber, neoprene, silicone, and the like. Ferromagnetic particles include iron, nickel, cobalt, and the like.

[0027] Material properties, including permeability, Young's modulus, and density of the composite material, can be realized by adjusting the ratios of particle to matrix binder material. Once such property is the propagation speed of Rayleigh waves. The propagation speed of Rayleigh waves in a solid material is approximately the square root of the ratio between stiffness and density. The propagation speed in rubber is approximately 55 m/s. The suspension of heavy ferromagnetic particles in a rubber matrix binder will yield a ferromagnetic particle infused elastomer material with high magnetic permeability and low wave speed relative to unmodified rubber material.

[0028] A layer of ferromagnetic particle infused elastomer may be deformed through the action of magnetic forces. If a layer of ferromagnetic particle infused elastomer is placed on a solid substrate and a magnetic field is passed through it from beneath the substrate, magnetic forces will be applied to the ferromagnetic particles inside the ferromagnetic particle

infused elastomer and the ferromagnetic particle infused elastomer will be compressed against the substrate in the vicinity of the magnetic field and a local depression will be formed. If the center of the magnetic field is moved, the center of the associated depression in the ferromagnetic particle infused elastomer will move accordingly.

[0029] Although a moving surface deformation in a ferromagnetic particle infused elastomer layer can be formed by mechanically moving a source of magnetic field beneath it, a superior approach is to place an array of electromagnets beneath the surface and move the center of the applied force by dynamically adjusting the energization level and pattern of the electromagnet array. The center of the magnetic field can thus be translated across the surface of ferromagnetic particle infused elastomer at any desired rate and or movement pattern.

[0030] Like any structure, surface waves will naturally propagate across the surface of a ferromagnetic particle infused elastomer layer if that layer is perturbed. For example, a linear wave initiated along one edge of a ferromagnetic particle infused elastomer will naturally travel across the ferromagnetic particle infused elastomer surface, while being gradually damped as it travels, until it reaches the opposite edge of the layer. It will travel at the natural Rayleigh wave speed of the surface. Wave motion dampening can be mitigated and the wave

propagation enhanced by applying phased forces to the ferromagnetic particle infused elastomer as the wave propagates. An array of electromagnets placed beneath the substrate of the ferromagnetic particle infused elastomer can be used to apply this phased forcing.

[0031] In the two dimensional instantiation of the concept outlined above is a linear array of electro magnets that can each be individually energized, the surfaces of which form a substrate on which a uniform layer of ferromagnetic particle infused elastomer is overlaid. Sequential actuation of the electromagnets forms a depression (and associated elevations preceding and following the center of the forcing) in the ferromagnetic particle infused elastomer that translates linearly across the ferromagnetic particle infused elastomer surface. This wave propagates most efficiently if the translation speed of the actuation matches the natural wave propagation speed (Rayleigh wave speed) of the ferromagnetic particle infused elastomer material.

[0032] Addition of a secondary surface parallel to the ferromagnetic particle infused elastomer substrate and offset from the upper surface of the ferromagnetic particle infused elastomer forms a gap above the ferromagnetic particle infused elastomer layer. Actuation of the ferromagnetic particle infused elastomer by the electromagnets creates void at the center of

force application and a constriction ahead of and behind the depression. As the depression translates, fluid trapped in the void is carried with the motion of the depression.

[0033] Fluid can be further separated from the peristaltic forcing mechanism by insertion of a tube in the gap between the ferromagnetic particle infused elastomer material and the secondary surface. Employing tubing in this manner effectively separates the peristaltic pump from the fluid flow circuit. Fluid flow can be driven in any compliant tube that can be inserted into the electromagnetically actuated ferromagnetic particle infused elastomer peristaltic pump.

[0034] Returning to **FIG. 1**, the first embodiment of the electromagnetically actuated ferromagnetic particle infused elastomer peristaltic pump is depicted. The curved backing plate **20** is connected to a frame **40** by a hinge **36**, on a first edge, and a clamping mechanism **38** on a second edge. Possible clamping mechanisms include thumb screws, wing nuts, latches, removable pins, and the like.

[0035] The frame **40** has a rectangular cross section with material removed from its upper surface forming a rectangular channel centered between a first side wall **44** and a second side wall **46** and extending along the length of frame **40**. First side wall **44** has tapped holes (not shown) uniformly spaced along its upper edge and extending downward into the side wall. Second

side wall **46** has a hinge **36** along its upper edge. Frame **40** has a linear array of cylindrical holes **42** through the bottom of the frame, each hole **42** centered along the frame width, and all of the holes spaced uniformly along the length of frame **40**. For illustrative purposes, eight holes **42** are used; however, any number of holes may be employed greater than two.

[0036] At least three electromagnets **50** are placed in the holes **42** in the frame **40**. Each of the electromagnets **50** is individually connected to a controller **60** via powering wires **62**. For illustrative purposes, eight holes **42** and eight electromagnets **50** are shown and described here. However, any number of electromagnets exceeding two may be employed to achieve the desired pumping effect.

[0037] FIG. 2 depicts a longitudinal cross section of the pump **10** taken along plane **2-2** of FIG. 1 with the flexible tubing **100** (not shown) removed. Electromagnets **51, 52, 53, 54, 55, 56, 57, and 58** are not energized in this figure. The composite material **30** is unperturbed due to the absences of electromagnetic forces imposed on the ferromagnetic particles **34**. A gap **70** exists between the composite material **30** and the backing plate **20**. A flexible tubing **100** (not show) could be placed in the gap **70** if physical separation between a working fluid **80** in the gap and the pump is required.

[0038] **FIG. 3** depicts a horizontal cross section of the pump **10** at a station where the electromagnet **54** is not energized. The flexible tubing **100** is shown in the gap **70** between the backing plate **20** and the composite material **30**. The flexible tubing **100** is partially compressed in this nominal state to allow expansion and compression as the composite material **30** deforms under the action of electromagnetic forces produced by the electromagnets (including electromagnet **54**).

[0039] **FIG. 4** depicts a longitudinal cross section of the pump **10** with the flexible tubing **100** (not shown) removed. The first three electromagnets **51**, **52**, and **53** and the last two electromagnets **57** and **58** are energized in this figure. The composite material **30** is deformed due to the forces imposed on the ferromagnetic particles **34** by the electromagnetic field caused by energization of electromagnets **51**, **52**, **53**, **57** and **58**. The depiction "N" and "S" indicate the polarity of the electromagnetic field. In the depicted energization pattern, the first electromagnet **51** is partially energized, the second electromagnet **52** is fully energized, and the third electromagnet **53** is partially energized. The electromagnetic field created by the electromagnets produces a compressive body force **59**, indicated by arrows on the composite material **30**. In the proximity of the body force **59**, a depression **37** in the composite material is created, thus increasing the size of the gap **70**

between the composite material **30** and the backing plate **20** in that area.

[0040] **FIG. 5** depicts a horizontal cross section of the pump **10** taken along line **5-5** of **FIG. 1** and **FIG. 4** at a station where the electromagnet **52** is energized. The flexible tubing **100** is shown in the gap **70** between the backing plate **20** and the composite material **30**. Due to the compression of the composite material **30**, the flexible tubing **100** is allowed to expand.

[0041] Returning to **FIG. 4**, it is shown that due to compression of the composite material **30** in the vicinity of the electromagnetic forces **59**, elastomeric material is forced ahead of and behind the area of compression forming wave crests **38**.

[0042] **FIG. 6** depicts a horizontal cross section of the pump **10** taken along line **6-6** of **FIG. 4** at a station to the right of where the electromagnets **50** are energized. The flexible tubing **100** is shown in the gap **70** between the backing plate **20** and the composite material **30**. Due to the presence of the wave crest **38** in the composite material **30**, the gap **70** is reduced in size at that location and the flexible tubing **100** is compressed accordingly.

[0043] To create a peristaltic pumping action, the axial location of the body force **59** is translated longitudinally by sequentially energizing and de-energizing electromagnets from left to right. The sequenced energization of an 8 electromagnet

pump is given in **TAB. 1**. The steps 1 through 6 are repeated at a desired frequency. A frequency equal to that associated with travelling Rayleigh waves will optimize system efficiency.

TABLE 1								
ELECTROMAGNET ENERGIZATION SEQUENCE (REPEATED)								
STEP	Magnet 51	Magnet 52	Magnet 53	Magnet 54	Magnet 55	Magnet 56	Magnet 57	Magnet 58
1	LOW				LOW	HIGH	LOW	
2	HIGH	LOW				LOW	HIGH	LOW
3	LOW	HIGH	LOW				LOW	HIGH
4		LOW	HIGH	LOW				LOW
5			LOW	HIGH	LOW			
6				LOW	HIGH	LOW		

[0044] The actuation pattern represented in **TAB. 1** may be modified to achieve equivalent compression effects in the composite material. The "LOW" and "HIGH" actuation states may be replaced by continuous analogue actuation states. Alternately the "LOW" and "HIGH" actuation states may be replaced by pure binary "ON" and "OFF" states.

[0045] **FIG. 7** depicts a longitudinal cross section of the pump **10** with the flexible tubing **100** (not shown) removed. Three electromagnets **53**, **54**, and **55** are energized in this figure. The composite material **30** is deformed due to the forces imposed on

the ferromagnetic particles **34** by the electromagnetic field caused by energization of electromagnets **53**, **54**, and **55**. If these three magnets are energized immediately after magnets **52**, **53**, and **54** are energized (which had followed magnets **51**, **52**, and **53**), translation of the depression **37** (relative to the location indicated in **FIG. 4**) will carry fluid **80** along the channel. The pumping action is enhanced by the translation of the wave crests **38**.

[0046] Formation and translation of wave crests **38** and depression **37** will occur through static action of the electromagnetic field. These effects are enhanced by matching the translation speed of the energization pattern with natural propagation speed of Rayleigh waves in the composite material **30**.

[0047] An electromagnetically actuated ferromagnetic particle infused elastomer peristaltic pump **10** will properly function without inclusion of a tube **100**. The channel formed between the composite material **30** and the backing plate **20**. However, employment of the electromagnetically actuated ferromagnetic particle infused elastomer peristaltic pump as a means to pump fluid through an independent flow circuit that includes the flexible tubing **100** is the primary object of this invention. As illustrated in **FIG. 8**, the electromagnetically actuated ferromagnetic particle infused elastomer peristaltic pump **10** is

opened by removing the clamping mechanism **38** and opening the backing plate **20** using hinges **36** attached to the frame **40**. Once the electromagnetically actuated ferromagnetic particle infused elastomer peristaltic pump **10** is opened, the flexible tube **100** can be inserted, the backing plate **20** closed, and the clamping mechanism **38** secured, the electromagnetically actuated ferromagnetic particle infused elastomer peristaltic pump is ready to be operated to pump fluid through the flexible tubing.

[0048] A second embodiment of the invention is depicted in **FIG. 9**. In this embodiment, the backing plate **20** (shown in **FIG. 3**) is replaced with a second frame **41**, a second composite elastomeric material **31**, and a second set of electromagnets **150**. The actuation of the second set of electromagnets **150** are activated to create deformations in the second composite elastomeric material **31** that mirror activation and deformations of the first elastomeric material **30**. The second frame **41** is joined to the first frame **40** by hinges **36** and latching means **38**. This second embodiment produces an improved peristaltic pumping action over the first embodiment, by creating larger volumetric changes in the gap **70** through the combined action of two composite elastomeric material **30** and **31** deformations as opposed to a single composite elastomeric material **30** deformation as described in the first embodiment. Although improved performance

Attorney Docket No. 112564

will be realized, the mechanical complexity of the system will be increased.

[0049] In light of the above, it is therefore understood that within the scope of the appended claims, the invention may be practiced otherwise than as specifically described.

RAYLEIGH WAVE ELECTROMAGNETIC PUMP

ABSTRACT OF THE DISCLOSURE

A pump employs electromagnetically generated Rayleigh waves in an elastomeric structure with embedded ferromagnetic materials to create a peristaltic pumping action. A frame has a base and two side walls defining a channel. Apertures extend through the base to the channel. A backing plate is joined to the frame side walls and defines a top of the channel. A composite elastomeric material with ferromagnetic particles in a binder is disposed in the channel. Electromagnets are provided in each aperture to interact electromagnetically with the elastomeric material. A controller is joined electrically to the electromagnets to independently activate each electromagnet. Activation of the electromagnets causes contraction of the elastomeric material to provide the pumping action.

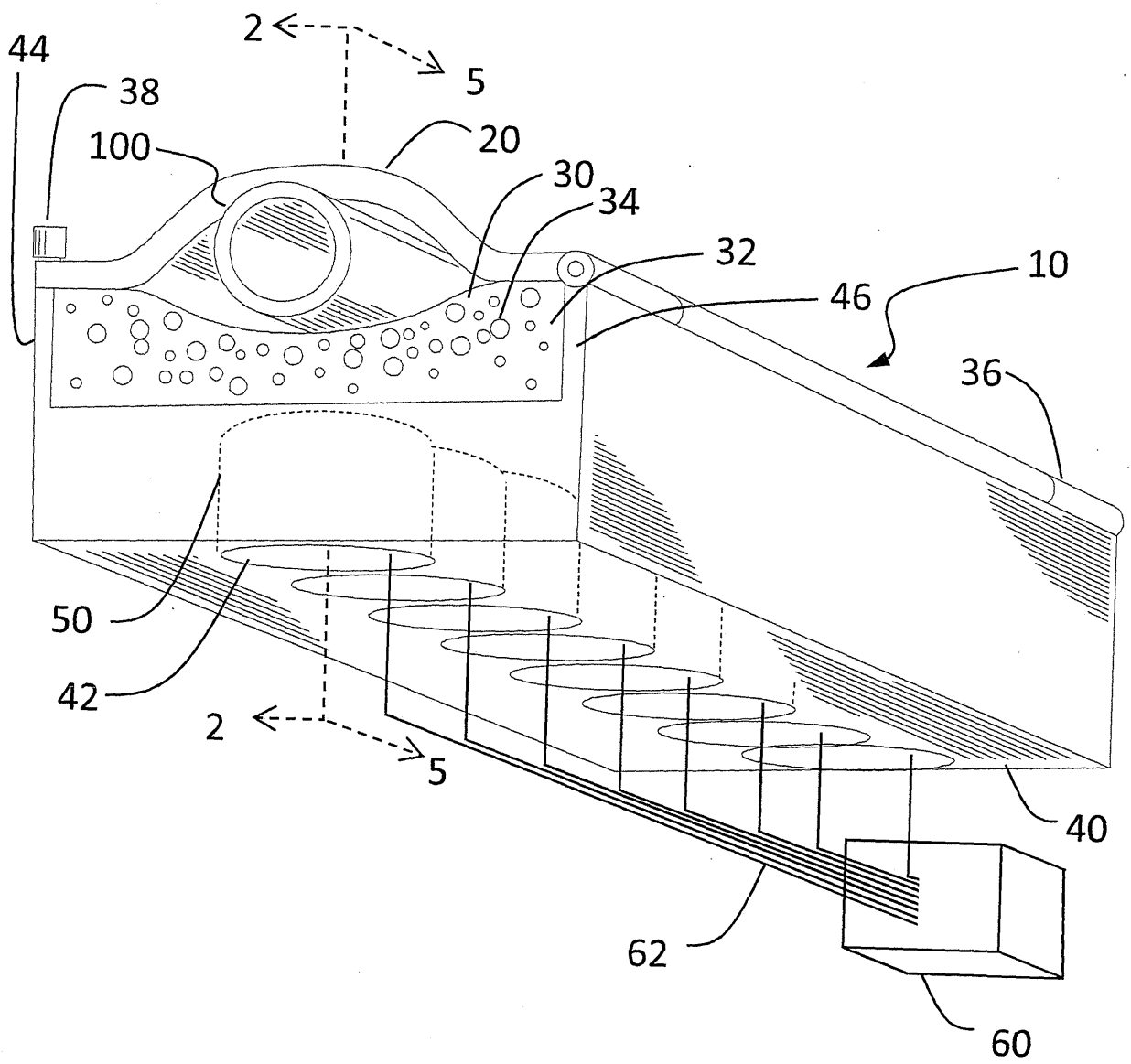

FIG. 1

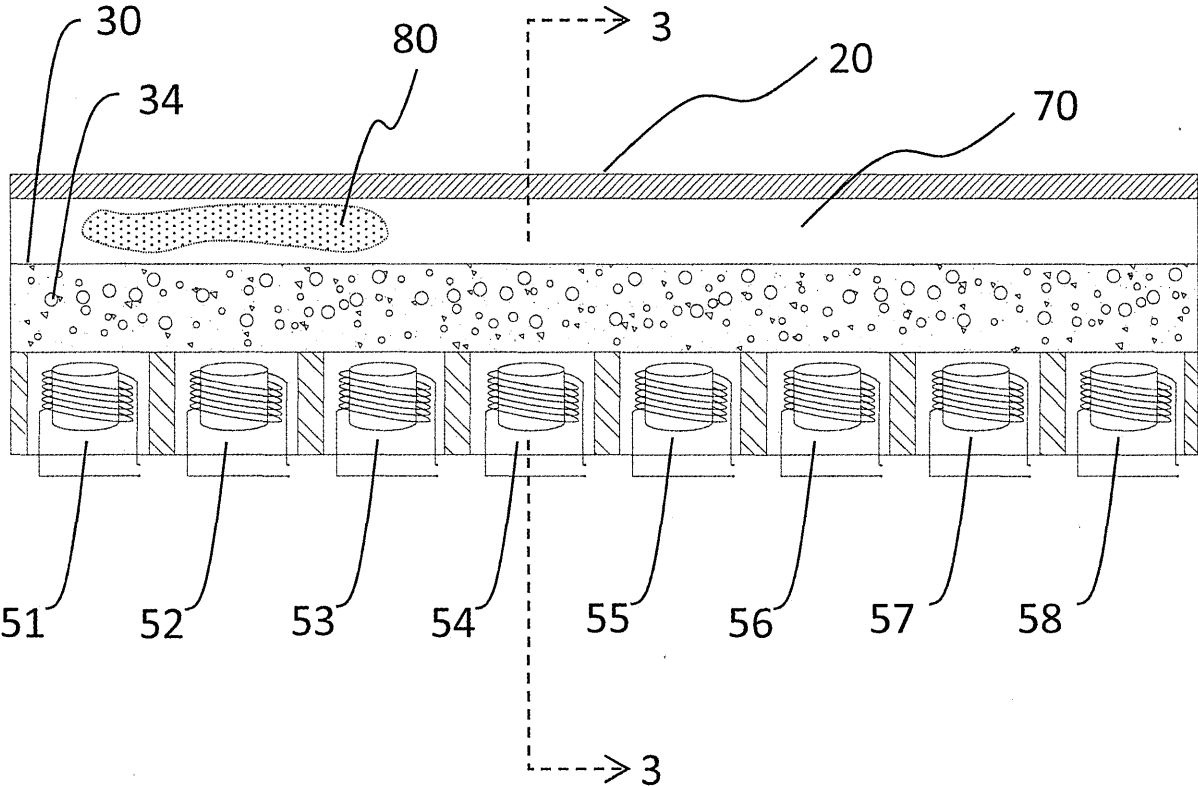

FIG. 2

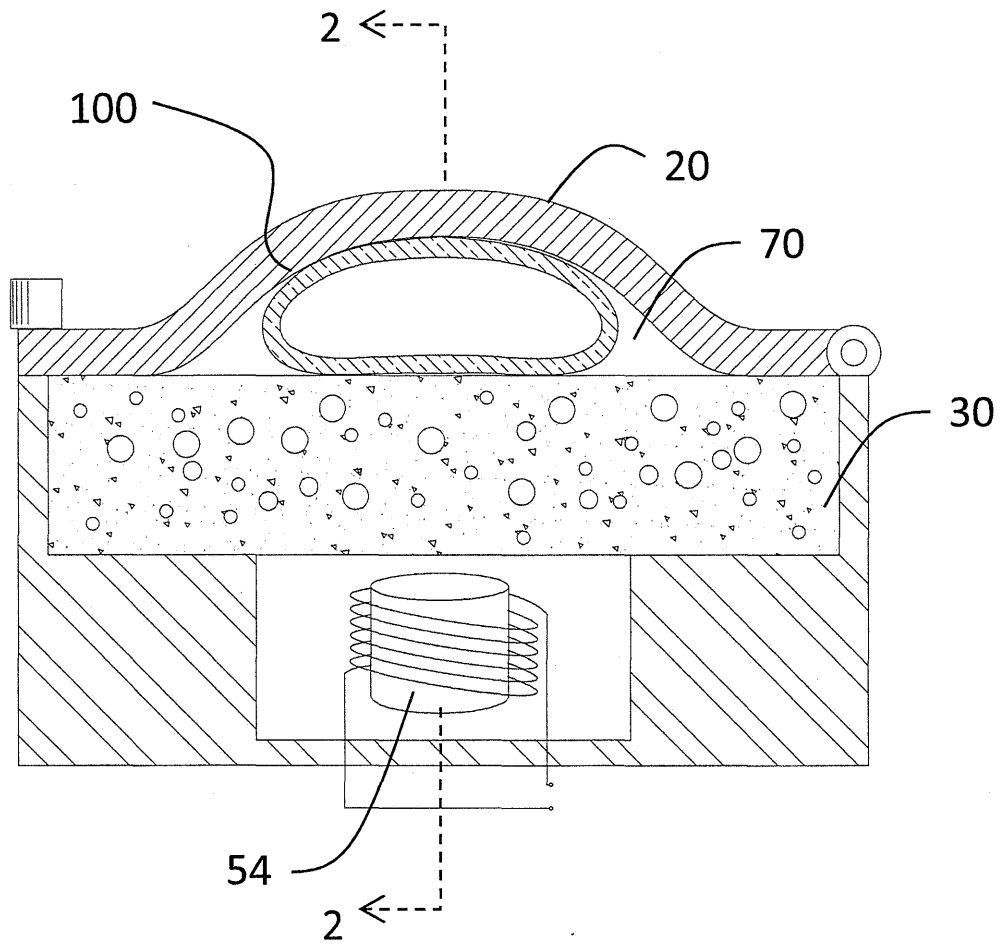

FIG. 3

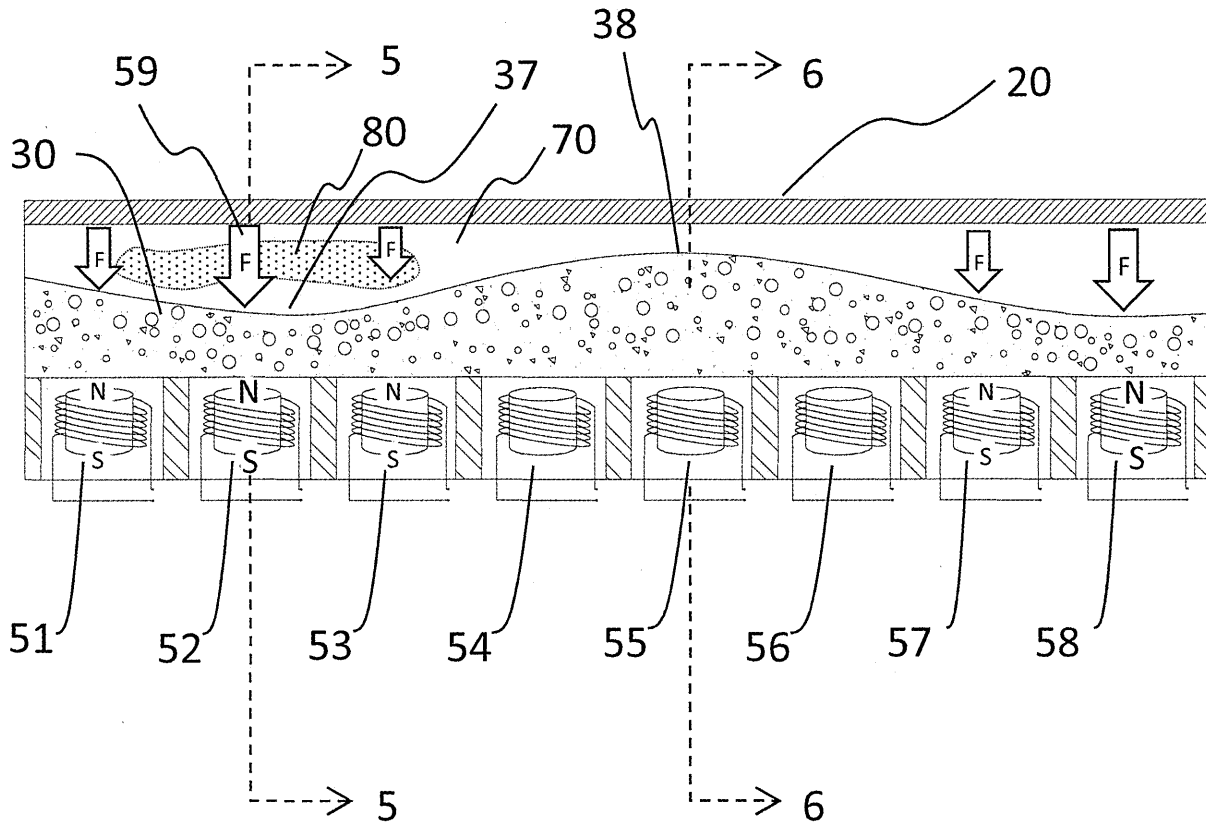

FIG. 4

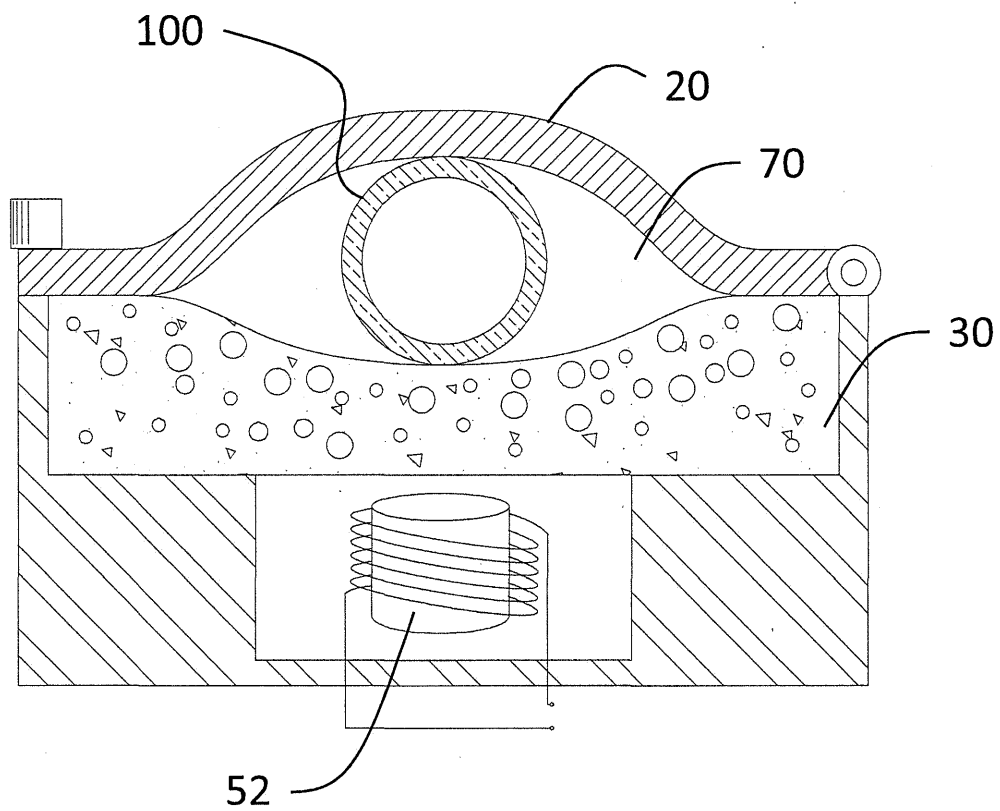

FIG. 5

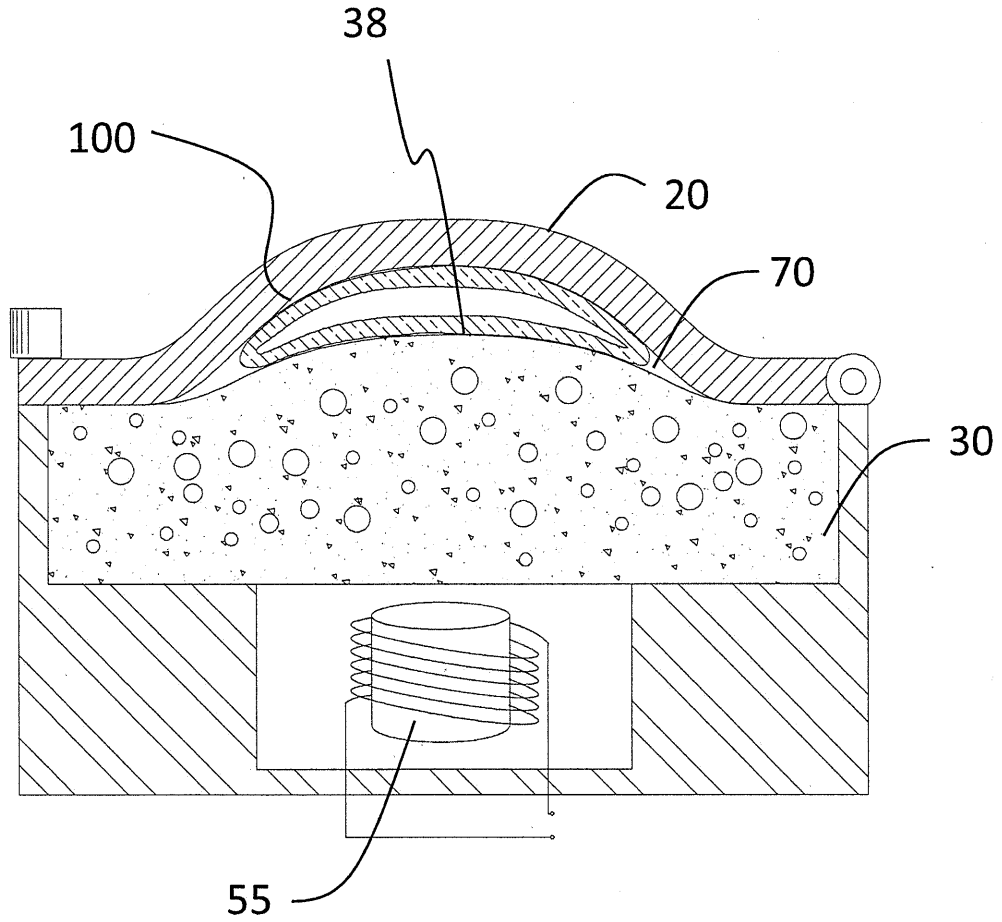

FIG. 6

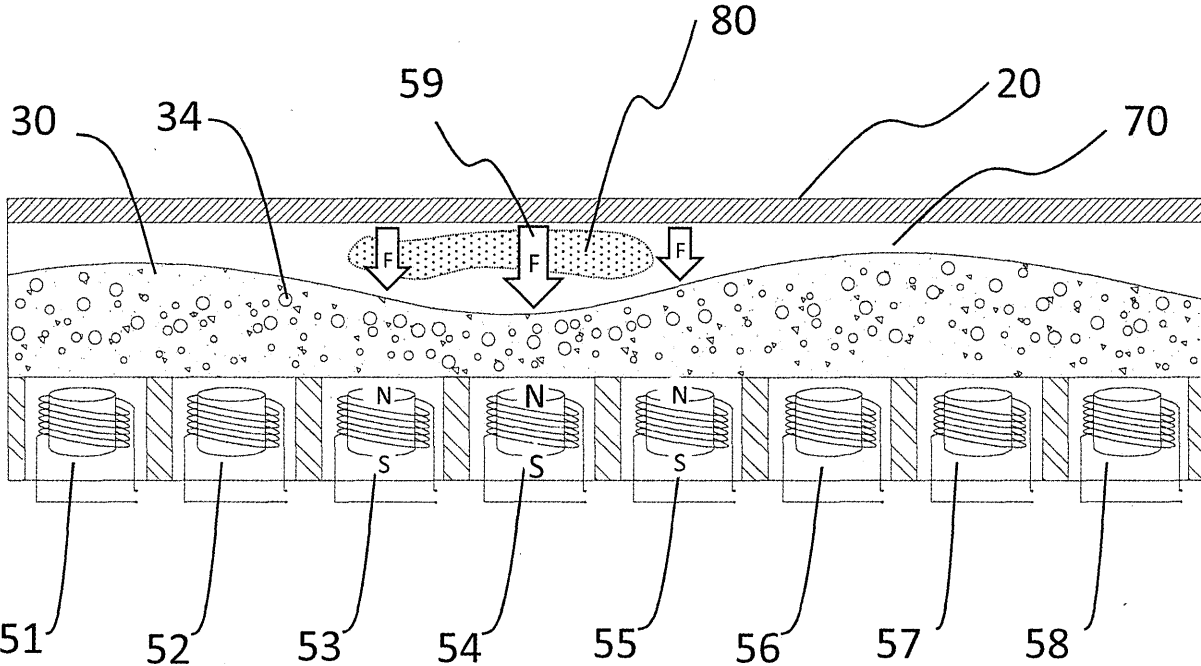

FIG. 7

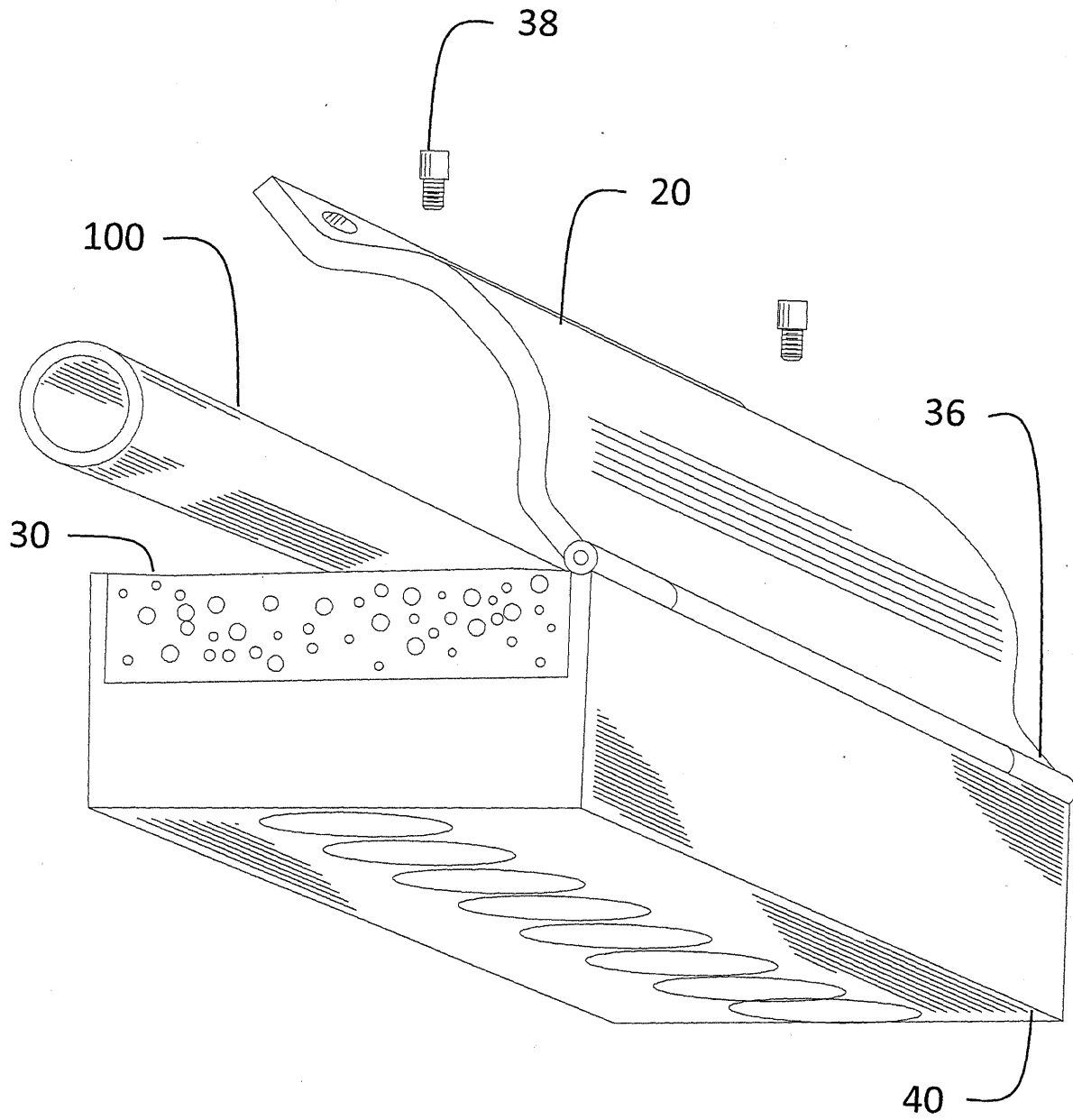

FIG. 8

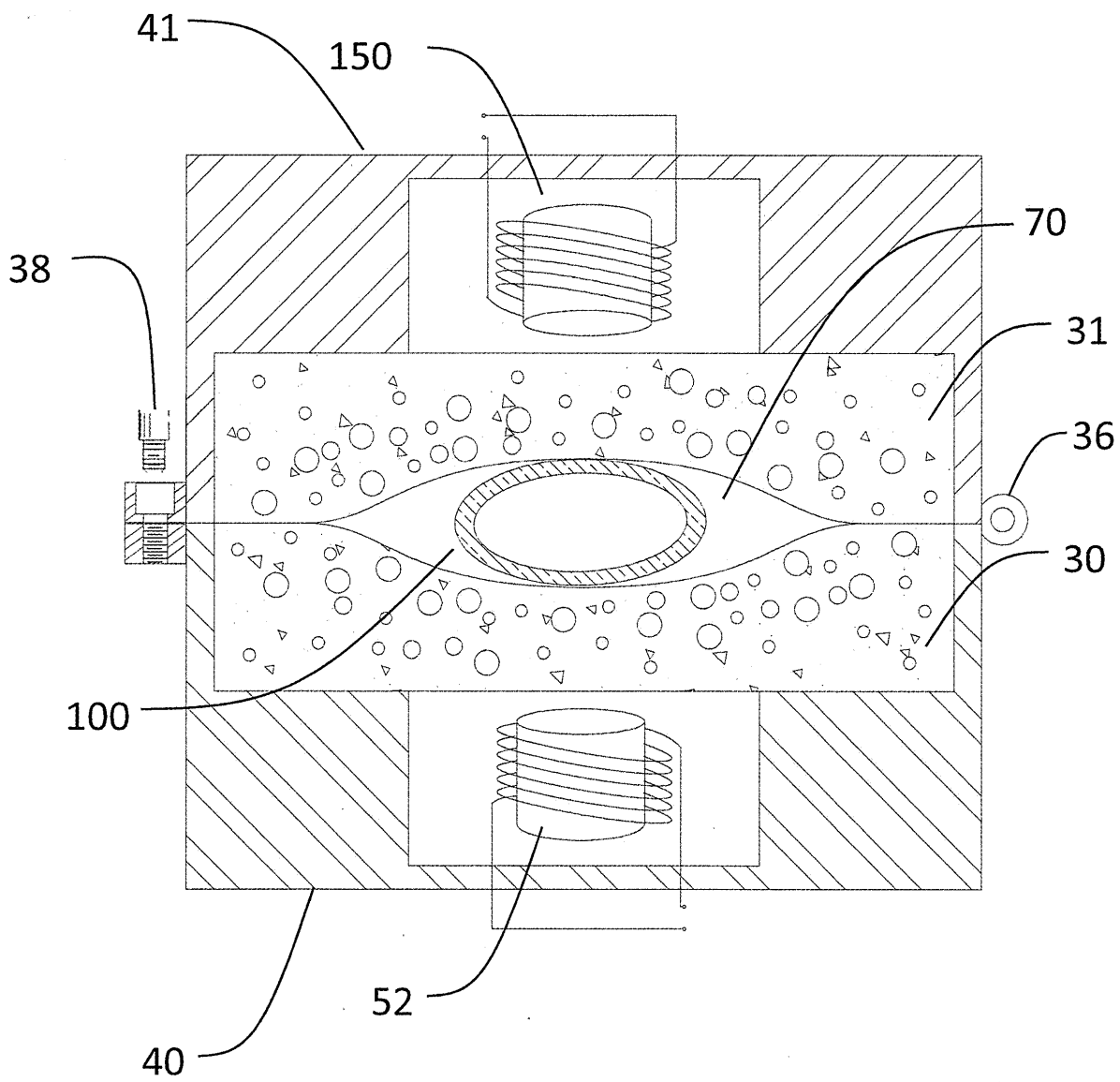

FIG. 9