



**US Army Corps
of Engineers®**
Engineer Research and
Development Center



Lock Operation Improvements

Stuart D. Foltz and Daniel E. Hooks

April 2021



The U.S. Army Engineer Research and Development Center (ERDC) solves the nation's toughest engineering and environmental challenges. ERDC develops innovative solutions in civil and military engineering, geospatial sciences, water resources, and environmental sciences for the Army, the Department of Defense, civilian agencies, and our nation's public good. Find out more at www.erdclibrary.on.worldcat.org/discovery.

To search for other technical reports published by ERDC, visit the ERDC online library at <http://www.erdclibrary.on.worldcat.org/discovery>.

Lock Operation Improvements

Stuart D. Foltz

*Construction Engineering Research Laboratory
U.S. Army Engineer Research and Development Center
2902 Newmark Drive
Champaign, IL 61822*

Daniel E. Hooks

*Chicago District, Lockport Lock
US Army Corps of Engineers
2502 Channel Dr.
Lockport, IL. 60441*

Final Technical Report

Approved for public release; distribution unlimited.

Prepared for Headquarters, U.S. Army Corps of Engineers
Washington, DC 20314-1000

Under Work Units L93CJ7 and 4B1176

Abstract

The U.S. Army Corps of Engineers (USACE) owns or operates 236 locks at 191 sites (HQUSACE 2016). Although the locks at these sites generally perform reliably, more than half of these structures have surpassed their 50-year economic design life, and as such, there are increasing concerns about their continued safe, reliable operation. This work was undertaken to review lock operating equipment, maintenance practices, records pertaining to accidents and equipment failures, and lighting systems; to identify alternative improvements to equipment and equipment maintenance practices; and to analyze and compare those alternatives to determine and recommend optimal solutions. This report documents some lessons learned, primarily to share information that others might find useful. Note that the recommendations in this report should *not* be viewed as policy, although some might be considered by those creating policy.

Contents

Abstract	ii
Figures	v
Preface	vii
1 Introduction	1
1.1 Background.....	1
1.2 Objective.....	1
1.3 Approach	1
2 Lock Operating Equipment	3
2.1 Encoders and resolvers.....	3
2.2 Gear box covers	4
2.3 Magnetic proximity switches and mitering cameras.....	5
2.4 Redundant closed switches	7
2.5 Cam-operated limit switch gearboxes.....	8
2.6 Overhead monitors	10
2.7 Lockport Lock valve hydraulic pumps	13
2.8 Gate solid-state timers (Starved Rock Lock).....	14
2.9 Surge protectors	16
3 Maintenance Improvements	17
3.1 Bumpers and fenders.....	17
3.2 Floating mooring bit cathodic protection.....	19
3.3 Hardened steel.....	19
3.4 Corrosion	20
3.5 Mooring bits	22
3.6 Reusable lock nuts	23
3.7 High grade premixed coolant and synthetic oil.....	23
4 Accident and Failure Prevention	25
4.1 Limit switch failure.....	25
4.2 Flushing accidents.....	26
4.3 Miter gate hammering.....	29
4.4 Improper interlock settings	29
4.5 Improper attendance of tow haulage units	30
4.6 Lack of security cameras	32
4.7 Improper generator starting: use solid-state time-delay relay.....	33
4.8 Improper input module selection.....	34
4.9 Misuse of master override keyswitch	35
5 Lighting	36
5.1 High mast lighting	36
5.2 LED lighting fixture replacements.....	38

5.3	Traffic lighting on river.....	42
5.4	Light poles.....	43
6	Conclusions and Recommendations	45
6.1	Conclusions.....	45
6.2	Recommendations.....	45
6.2.1	<i>Lock operating equipment</i>	<i>45</i>
6.2.2	<i>Maintenance improvements.....</i>	<i>46</i>
6.2.3	<i>Accident and failure prevention.....</i>	<i>46</i>
6.2.4	<i>Lighting.....</i>	<i>48</i>
	References.....	49
	Acronyms and Abbreviations.....	50
	Report Documentation Page (SF 298).....	51

Figures

Figures

1	Resolver at Lockport Lock	4
2	Resolver at Marseilles Dam.....	4
3	Gearbox cover at Lockport Lock	5
4	Magnetic proximity switch Lockport Lock	5
5	Magnetic proximity switch location in Nashville District.....	6
6	Magnetic proximity switch and mitering camera - New Orleans District.....	7
7	Close-up of redundant closed switch at Starved Rock Lock	8
8	Cam-roller arms on redundant closed switch at Starved Rock Lock.....	8
9	Old cam-operated limit switch gearbox at Brandon Road Lock.....	9
10	Gearbox with two vertical shafts, one horizontal shaft, and six total bearings.....	10
11	Overhead monitors control room Port Allen.....	11
12	Pre-renovation Port Allen control room.....	11
13	Post-renovation control room Port Allen.....	12
14	Brandon Road control panels	12
15	Newer model Vickers valve pump.....	13
16	Older model Vickers valve pump.....	14
17	Panel box with solid-state timer	15
18	Enlarged solid-state timer.....	16
19	Wood bumpers attached to miter gate.....	17
20	Plastic bumpers attached to miter gate	18
21	Different fender framing systems	18
22	Lower valve wear tracks at Lockport Lock	20
23	Hydraulic system on emergency gate.....	21
24	Lockport Lock emergency gate corrosion photos	22
25	Old mooring bit	22
26	New mooring bit.....	22
27	Non-reusable and reusable lock nuts	23
28	High grade premixed coolant	24
29	High grade synthetic oil.....	24
30	Brandon Road Lock CLOSED limit switch failure.....	28
31	Minimum fix done at New Orleans District Locks after the 2009 Markland Lock miter gate calamity (fix protects lower miter gates in “interlock bypass” and normal modes)	28
32	Debris at unknown lock gate.....	28
33	Crack caused by flushing accident at Lockport Lock.....	28
34	Lockport Lock emergency gate bent beam damage	32

35	Hydraulic tow haulage unit at Peoria Lock.....	33
36	Hydraulic tow haulage unit at Lockport Lock.....	34
37	Bridge security gate damage at 16 th Street.....	33
38	Generator solid-state time-delay relay at Lockport Lock	38
39	High mast LED lighting at Winfield Locks and Dam.....	39
40	Before (left) and after (right) LED replacement at Starved Rock.....	39
41	LED lighting used at Lockport Lock	39
42	480w LED retrofits at Lockport Lock.....	39
43	LED lighting upgrade at Lockport Lock	41
44	Tow haulage unit lighting at Lockport Lock.....	41
45	Lower miter gates lighting improvement at Lockport Lock.....	42
46	LEDtronics LED retrofit at Lockport Lock	42
47	Lumark Lockport cable building lighting	43
48	Traditional signal at upstream lock gate	44
49	New LED light style fixture	42
50	Light pole at Lockport Lock	43

Preface

This study was conducted for Headquarters, U.S. Army Corps of Engineers (USACE) under Project Structural Monitoring System for Lock Structures to Prevent Failure (Work Items L93CJ7 and 4B1176). The technical monitor was Charles (Eddie) Wiggins, Technical Director, Navigation.

The work was performed under the direction of the Materials and Structures Branch, of the Facilities Division, U.S. Army Engineer Research and Development Center, Construction Engineering Research Laboratory (ERDC-CERL). At the time of publication, Vicki VanBlaricum was Chief of the Materials and Structures Branch; Ms. Giselle Rodriguez was Chief of the Facilities Division; and Mr. Kurt Kinnevan was the Technical Director for Installations. The Acting Deputy Director of ERDC-CERL was Dr. George Calfas and the Interim Director was Dr. Kumar Topudurti.

COL Teresa A. Schlosser was Commander of ERDC, and Dr. David W. Pittman was the Director.

THIS PAGE INTENTIONALLY LEFT BLANK

1 Introduction

1.1 Background

The U.S. Army Corps of Engineers (USACE) owns or operates 236 locks at 191 sites (HQUSACE 2016). Although the locks at these sites generally perform reliably, more than half of these structures have surpassed their 50-year economic design life, and as such, there are increasing concerns about their continued safe, reliable operation. Various components of these systems that are out of date can be replaced for long term reliability and cost efficiency. This work was undertaken to review lock operating equipment, maintenance practices, records pertaining to accidents and equipment failures, and lighting systems; to identify alternative improvements to equipment and equipment maintenance practices; and to analyze and compare those alternatives to determine and recommend optimal solutions.

1.2 Objective

The objective of this study was to

- review lock operating equipment (including lighting systems), maintenance practices, and related accidents and equipment failures
- identify, analyze, and compare potential improvements that will help with simple lock operations
- recommend optimal solutions.

1.3 Approach

The following lock operating (and lighting) equipment was reviewed:

- Operating equipment:
 - encoders and resolvers
 - gear box covers
 - magnetic proximity switches and mitering cameras
 - redundant closed switches
 - cam-operated limit switch gearboxes
 - overhead monitors
 - pumps
 - gate solid-state timers
 - surge protectors

- Lighting equipment
 - high mast lighting
 - Light emitting diode (LED) lighting fixture replacements
 - traffic lighting on river
 - light poles.

Improvements to the following maintenance practices were reviewed:

- Bumpers and fenders
- Floating mooring bit cathodic protection
- Hardened steel
- Corrosion
- Mooring bits
- Reusable lock nuts
- High grade anti-freeze and synthetic oil.

The following types of accidents and equipment failures were reviewed:

- Limit switch failure
- Flushing accidents
- Miter gate hammering
- Improper interlock settings
- Improper attendance of tow haulage units
- Lack of security cameras
- Improper generator starting: use solid-state time-delay relay
- Improper input module selection
- Misuse of master override keyswitch.

Recommendations were made to improve equipment operation and equipment maintenance practices.

2 Lock Operating Equipment

There are many different components of equipment and machinery at a lock gate. They will be analyzed and compared to some possible alternatives.

2.1 Encoders and resolvers

When discussing RESOLVERS, people often interchange terms such as: encoders, rotary position sensors, motion feedback sensors, and transducer sensors. On occasion, synchros (cousin to the resolver) are also mentioned when explaining devices of this nature. Regardless of the names people choose to describe resolvers, their role in the world of automation remains unparalleled.

Referenced as an analog sensor that is absolute over a single-turn, the resolver was originally developed for military applications and has benefited from more than 50 years of continuous use and development. It was not long before numerous industrial segments recognized the benefits of this rotary position sensor, engineered to withstand the punishment of a military application. Product packaging plants and stamping press lines are perfect examples of where you might find resolver based systems at work. In typical applications, the resolver sensor feeds rotary position data to a decoder stationed in a Programmable Logic Controller (PLC) that interprets this information and executes commands based on the machines' position (AMCI Undated).

Many locks use encoders to convert the angular motion of the gate to a digital signal. Although resolvers (Figure 1) work similarly to encoders, they convert the motion to an analog signal. It has become apparent that resolvers are much better for this purpose. Resolvers have only one moving part, which significantly decreases their chances of premature failure. Resolvers are rated to -40°F , the highest standard. Overall, resolvers are more accurate, more reliable, and much longer lasting than encoders.

In 2005, single-turn, stainless steel resolvers were installed at the Marseilles Dam (Figure 2) in place of optical encoders. These units proved to be very reliable; so far there have been no failures. Resolvers also installed at the Lockport Lock in 2005 have demonstrated much higher reliability than the encoders used before the switch. This field experience helps confirm the

observation that resolvers are more reliable and better suited to this purpose than optical encoders. Reason for the excellent resolver reliability, is because resolvers do not have optics that can become contaminated like optical encoders do. Encoders are not recommended in humid environments.

Figure 1. Resolver at Lockport Lock.



Figure 2. Resolver at Marseilles Dam.

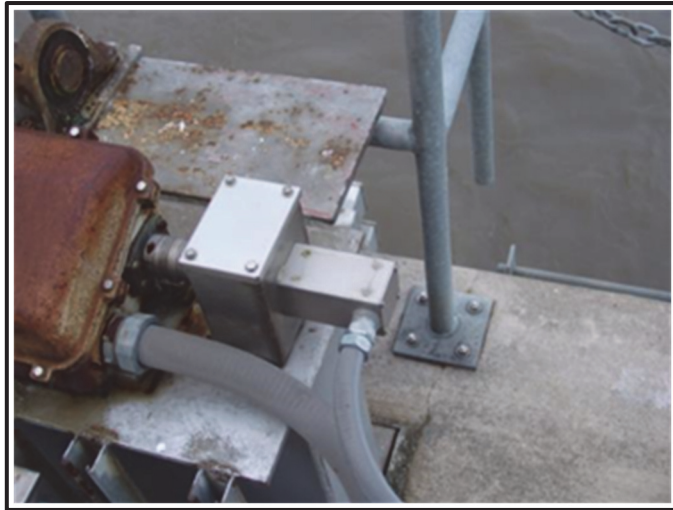

Keep in mind that “for existing and new installations, resolvers can only replace encoders if the input device can accept resolver sine/cosine input signals as an alternative to encoder pulse input” (Nidec Avtron). Lockport Lock uses PLC 5 series resolver input modules, which are very reliable if properly grounded and protected with quality surge protection, and which are also compatible with A/B Rockwell PLCs. Typically, new resolver input device will be required, and new cable.

2.2 Gear box covers

Gear box covers are essential to keep water and snow out of the gear box. Since the upper shaft seal of the gear box does not provide a perfect seal, water will inevitably end up in the machinery if the gear box is not provided with a cover. Gear box covers also protect gear oil against contamination. Although some lock locations filter their gear oil to remove water, this additional step could be avoided entirely by simply installing a gear box cover. Gear box covers are simple and reliable; in over 20 years of service, the gear box cover at Lockport Lock (Figure 3) has only blown off one time due to a microburst in a bad wind storm.

Locks that use encoders sometimes find it difficult to use gear box covers since covers for encoders are twice as high as covers for resolvers. This

meant that the locks with the old mechanical gate position controls would also need taller covers. Lockport Lock used to have taller covers with old mechanical gate position controls, which were cut in half for the resolvers.

Figure 3. Gearbox cover at Lockport Lock.



2.3 Magnetic proximity switches and mitering cameras

Magnetic proximity switches are used to detect when the gate is properly mitered (Figures 4 and 5). Equipment has a preset distance and an adjustable mount. Biggest magnet size is best, as it allows for largest gap between proximity switch and magnet. Magnetic proximity switches are more dependable than contact switches since they make less physical contact and thereby incur a lesser chance for damage. One of the primary advantages to using magnetic proximity switches is that they help to avoid icing problems. Also, proximity switches are rated at -40°F , the highest standard.

Figure 4. Magnetic proximity switch Lockport Lock.



Figure 5. Magnetic proximity switch location in Nashville District.

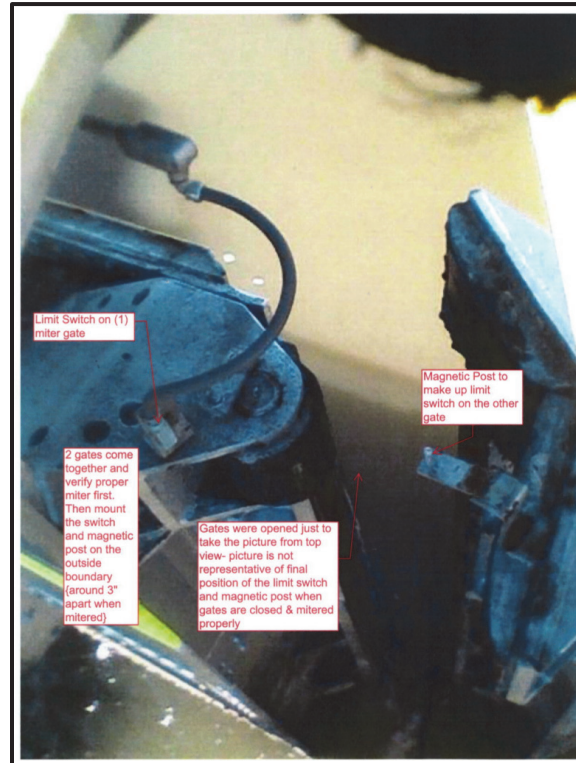

Not all proximity switch manufacturers offer extended-range magnets. When the magnets are not properly accounted for, problems will arise that are difficult to correct. It is recommended that there should be a universal requirement to use a manufacturer that offers the extended-range magnets to avoid this potential miscommunication. Suggest minimum gap of 3.5". Disqualify if manufacturer does not offer extended-range magnet that can meet specifications.

It has been noted that the proximity switch location on the lower miter gates downstream would not work on any upper miter gates, as the proximity switch and magnet would be exposed to damage from barge impact when the upper miter gates are open. Switches have been damaged in the past at Mobile District, because of this reason. Figure 6 shows the proximity switch location used at New Orleans District. This location may be more suitable for low-lift locks because the proximity switch is not placed on the downstream side of the miter gates. In other words, when the chamber is empty and the upper or lower gates are open, the proximity switch is recessed and high enough, so that it cannot be damaged by barge impact as the barge enters and exits the lock chamber. As a practice, it is best to locate the mitering proximity switch and magnet at top/midpoint

like Nashville District and New Orleans District do. Damage can be prevented.

Mitering camera (Figure 6) allows operators to verify mitering on a human machine interface (HMI) PC.

Figure 6. Magnetic proximity switch and mitering camera - New Orleans District.

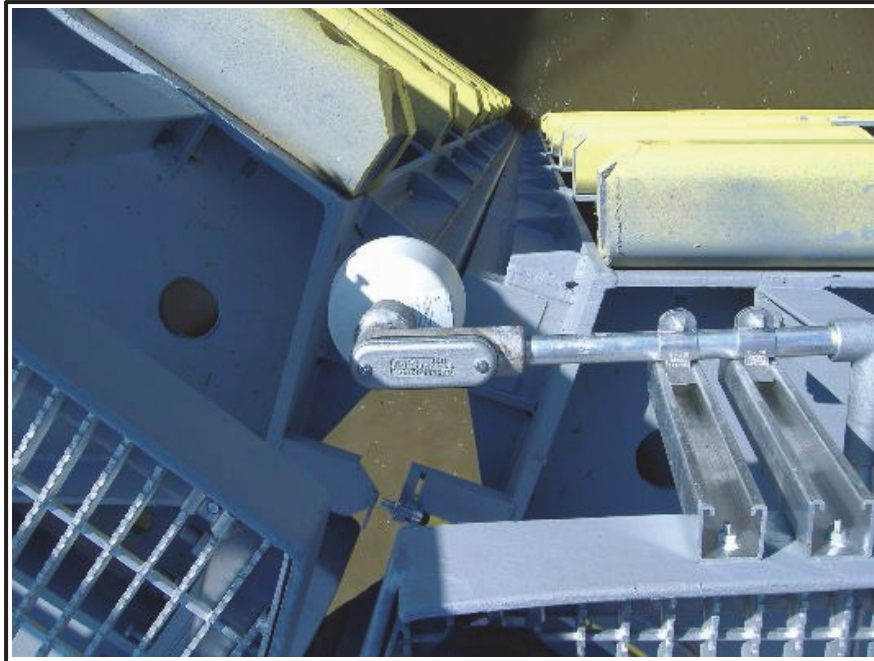

2.4 Redundant closed switches

The purpose of redundant closed switches (Figures 7 and 8) is to stop the valve machinery from pushing-up of the concrete if one switch fails, which oftentimes results in the breaking of the anchors. If anchors are broken, a host of problems can result. There have been various accidents in the past at the Illinois Waterway (IWW), where the valve machinery anchors have broken due to a single closed switch failure. To avoid this occurrence, both of the valve closed switches should be set at the same point.

The open switch, however, is not required to be redundant, as there would not be enough over-travel in the up direction to do any damage; the valve would just go into relief pressure. Most of the switches at Lockport Lock are A/B. Brandon Road Lock has converted valves to proximity switches.

Figure 7. Close-up of redundant closed switch at Starved Rock Lock.



Figure 8. Cam-roller arms on redundant closed switch at Starved Rock Lock.



2.5 Cam-operated limit switch gearboxes

The cam switches replaced at Lockport Lock have rubber rollers that, over time, became grooved by wear. This wear causes them to roll faster than they were originally calibrated to do. As the rollers become grooved, they lose some of their accuracy. The cam switches rotate and accumulate dust and moisture, which causes the switches to sometimes move incorrectly and to lose some of their ability to properly hold their position and to correctly connect with the switch they are supposed to trip. Historically, this has shown itself to be the cause of many disasters and “near-misses” at such sites as Mel Price Lock and Brandon Road Lock. Note that gearbox covers at the Lockport Lock gate used to be twice as tall when the old cam-operated limit switches were in use (See, for example, Figure 9).

Figure 9. Old cam-operated limit switch gearbox at Brandon Road Lock.



Figure 10, for example, depends on a total of six bearings. These failures usually cause the bull-gear to drive off the drive gear, due to the gear teeth skip, throwing the cam-operated limit switches out of calibration. This can result in catastrophe. A forensic analysis done after a failure at Lockport Lock revealed that the gearbox bearings had been manufactured in Taiwan. Even before this failure, records showed that the gearbox had a high failure rate of these replacement bearings. All locks need good, quality metering proximity switches. This will not prevent cam switch failures but will prevent associated accidents. Based on this experience, it is recommended that bearings from Japan be ordered, as they are more reliable and will make the gearboxes for the cam switches last much longer.

Figure 10. Gearbox with two vertical shafts, one horizontal shaft, and six total bearings.

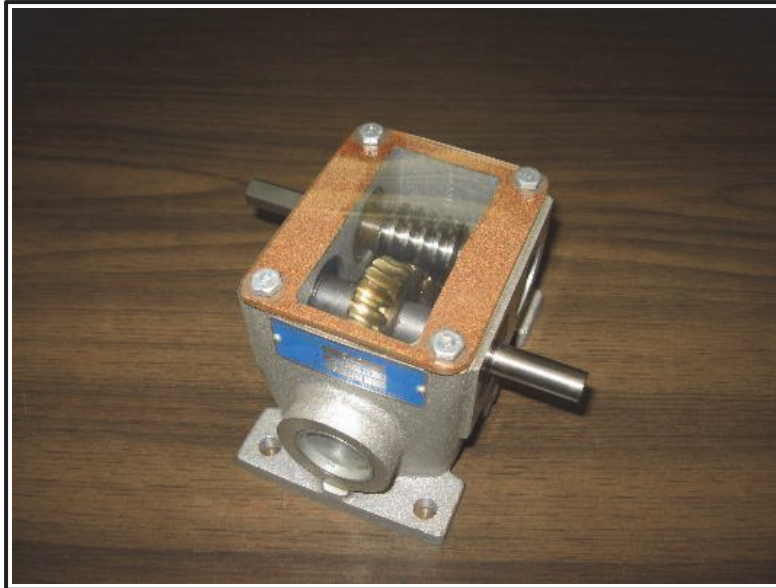

2.6 Overhead monitors

Control panel rooms for many gates may benefit greatly from renovation. For example, a remodel of the control room at Port Allen consisted of installing the system, gutting the control room, adding custom consoles, installing new wall tiles, adding architectural ceiling, and installing overhead consoles (Figure 11) for various cameras that allow operators to view the quality of the miter. Figures 12 and 13 show the Port Allen control room before and after renovation.

Brandon Road Lock still has its original 1930s vintage control panels (Figure 14). The old obsolete mechanical gate position controls still remain. Modernized control panels may be able to fit small PLC Input/Output (I/O) racks into the new control panels when the lock gets PLC/resolver upgrades. Proximity switches and extended-range magnets can be installed before that. Proximity switches will prevent damage resulting from mechanical gate positions controls failure and operator not checking mitering.

Figure 11. Overhead monitors control room Port Allen.



Figure 12. Pre-renovation Port Allen control room.



Figure 13. Post-renovation control room Port Allen.

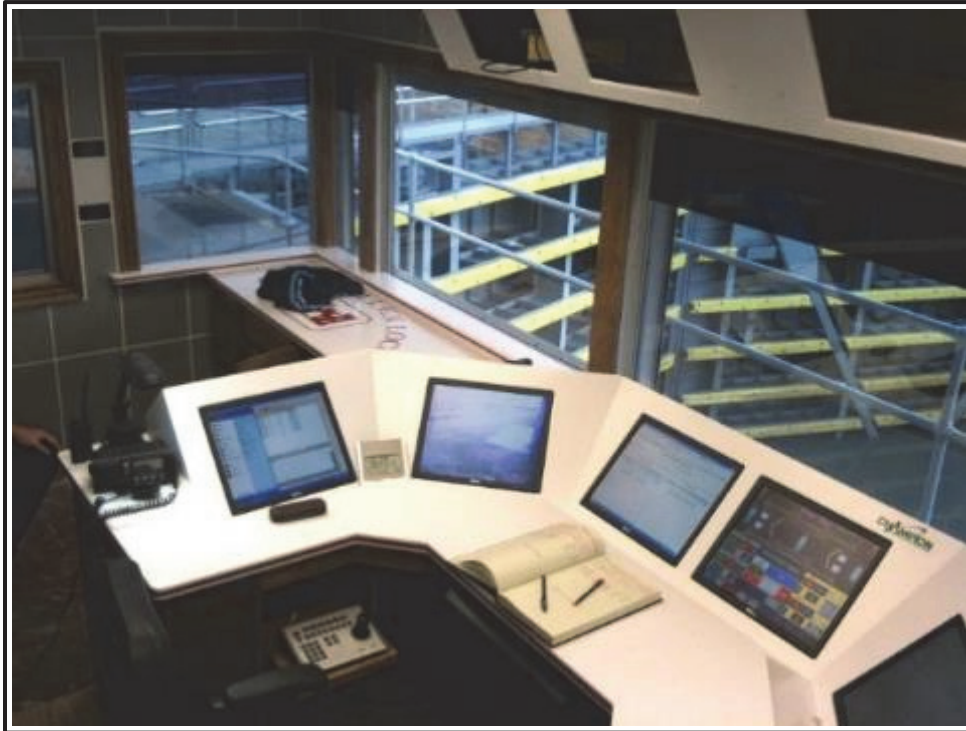

Figure 14. Brandon Road control panels.



2.7 Lockport Lock valve hydraulic pumps

Smaller pumps, as shown in Figure 15, are a cheaper option, with a similar expected life compared to older pumps seen in Figure 16. They are easier to install and less expensive to rebuild (use cartridges).

Always use a good-quality S/S pump suction filter in hydraulic reservoirs.

Figure 15. Newer model Vickers valve pump.



Figure 16. Older model Vickers valve pump.

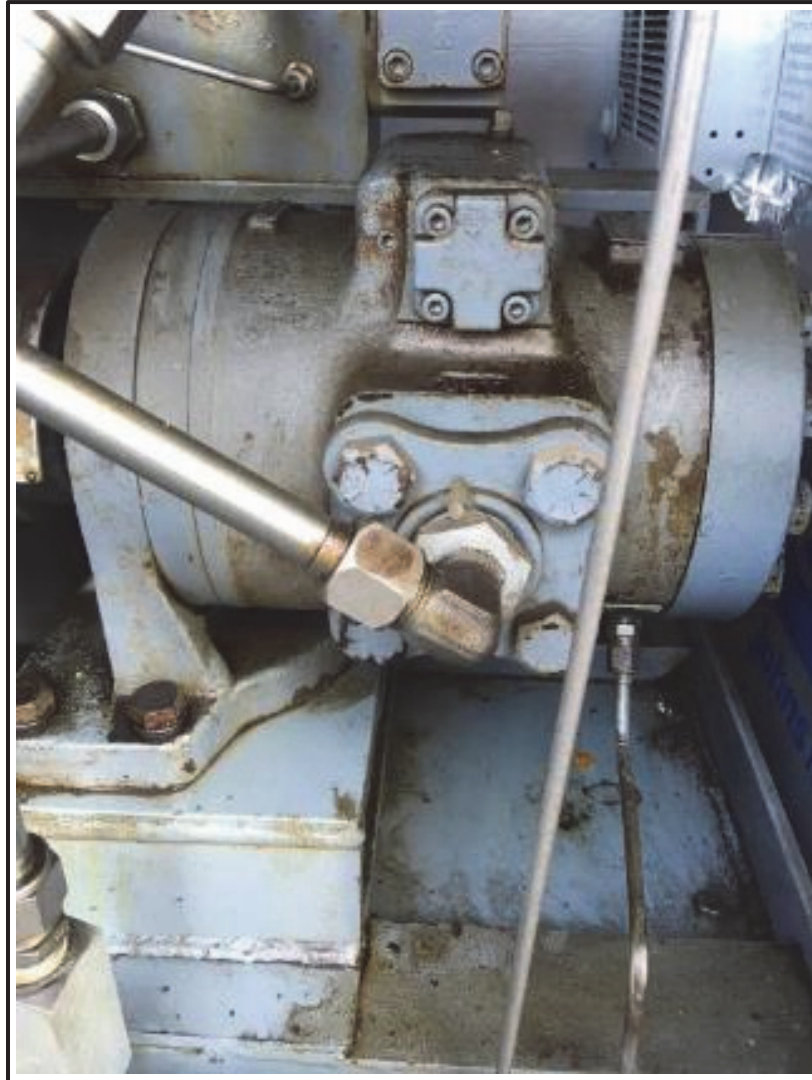

2.8 Gate solid-state timers (Starved Rock Lock)

Gate solid-state timers, which have minimal moving parts, replaced old mechanical timers. Figure 17 shows a gloved hand holding an old mechanical timer next to a new solid-state timer (shown in Figure 18 and is preferable compared to mechanical timers). Lockport Lock uses PLC (software) timers, which are ideal for this application (nothing will wear out in the PLC program).

Figure 17. Panel box with solid-state timer.

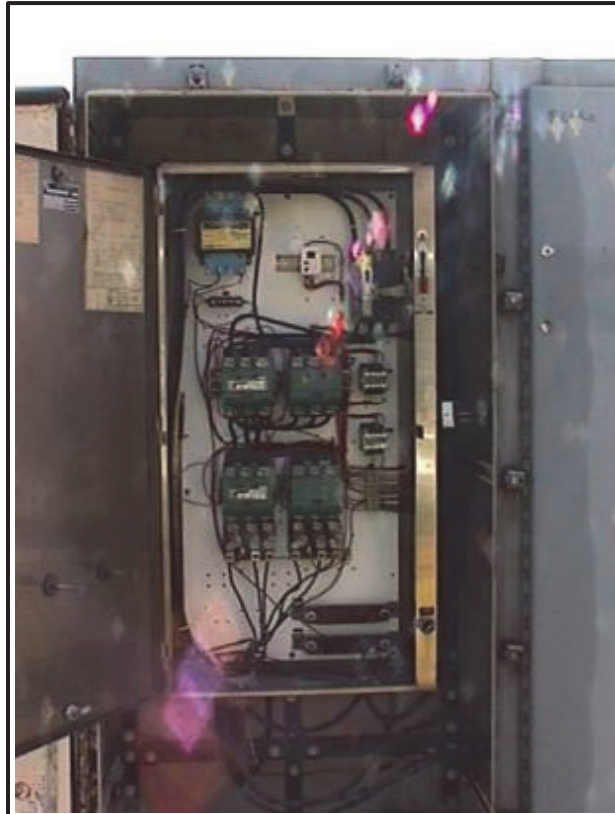
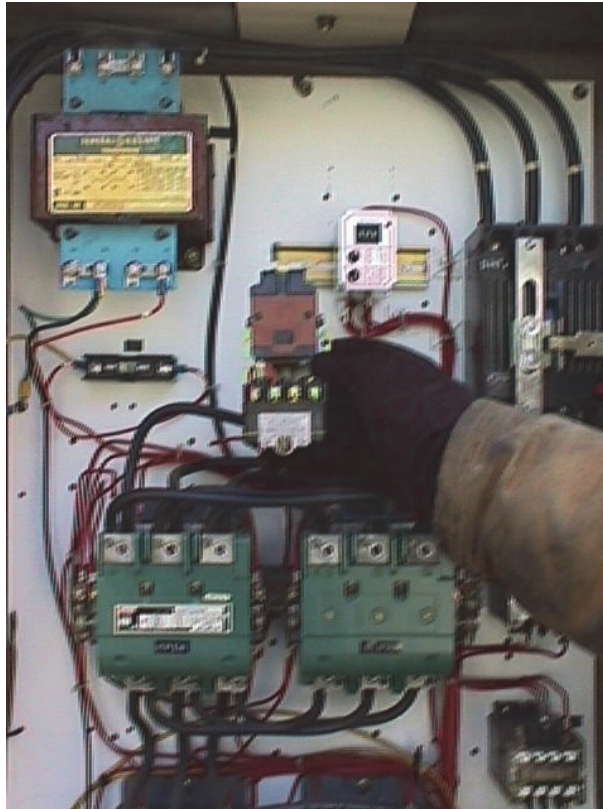

Figure 18. Enlarged solid-state timer.



2.9 Surge protectors

Since lock sites are prone to get a large amount of lightning strikes, it is important to include surge protection as part of the installation of any electronic instruments. For example, electronic tow haulage units, which are used on some locks on the Mississippi River, use surge protectors.

3 Maintenance Improvements

3.1 Bumpers and fenders

One maintenance strategy is to use bumpers to protect the miter gate from damage due to a barge impact. Some districts have great success with wood bumpers (Figure 19). Based on unit cost, wood is relatively cheap compared to alternative materials. However, if bumpers must be frequently replaced, the cost of wood bumpers over time can become more expensive than the cost of alternative, more durable materials. (Even more importantly, frequent replacements may interfere with lock operation.)

For example, plastic lumber (Figure 20) is more durable and far more abrasion resistant than wood. One drawback to the use of plastic lumber is that it sometimes gets pulled off by the bolts. The center cores of the timbers are softer, making it more prone to pulling off. This is especially the case if the bolt holes are slotted for differential thermal expansion.

Figure 21 (left) shows a “Cadillac” composite system. It is plastic for abrasion, rubber for light energy absorption, and steel for heavy impacts. Figure 21 (right) shows a custom-welded shape, which is a more expensive option compared to standard steel shapes.

Figure 19. Wood bumpers attached to miter gate.

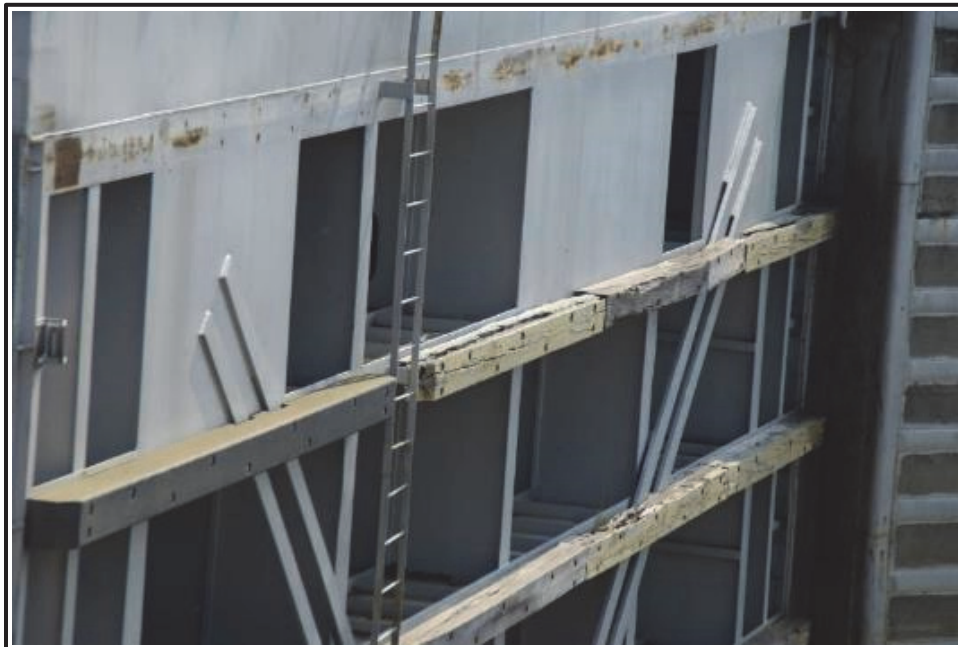
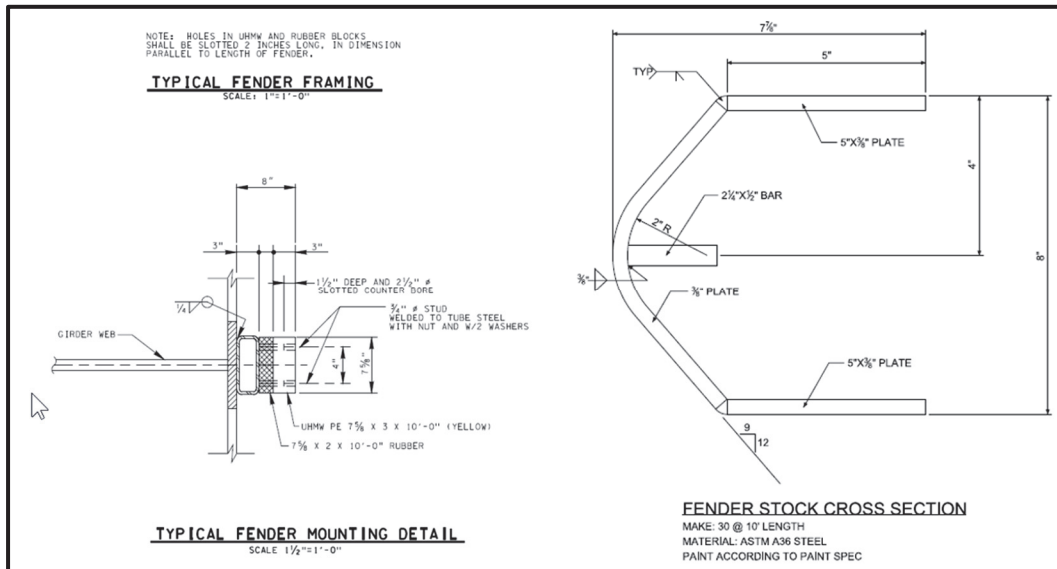

Figure 20. Plastic bumpers attached to miter gate.



Figure 21. Different fender framing systems.



3.2 Floating mooring bit cathodic protection

Floating mooring bits with cathodic protection were installed at Lockport Lock. The improvement has not worked very well, as it did not follow the model Jamie Whitten Lock provided, which implemented this for many years without any safety issues. Jamie Whitten uses anode bands, which work better than anode blocks. Passive cathodic protection uses sacrificial anodes, while active cathodic protection uses alternating current (AC) that is converted to direct current (DC) at multiple locations on the structure.

3.3 Hardened steel

Hardened steel is an effective way to address the problem of valve wear tracks becoming worn (as seen in Figure 22), which ultimately puts valves out of service. The upper valves at Lockport Lock have used hardened steel for 10 years now, and they are still working well with no valve problems or high hydraulic pressures noted. The hardened steel, often called “Australian Steel,” has deep-hardening. It is special ordered and takes 3 months to obtain. Deep-hardening is preferable to layered hardening as it lasts longer. Upper valve wear tracks were finally replaced, but deep-hardening work best.

Figure 22. Lower valve wear tracks at Lockport Lock.



3.4 Corrosion

Corrosion is an issue that may occur on many different components or parts at lock sites. Any part that is exposed to humidity or water may become corroded. If not addressed, corrosion can become a very costly problem. The emergency gate at Lockport Lock shows significantly more corrosion than does the service gate, as the service gate was converted to S/S pipes. Figure 23 shows the emergency gate piping, which was in critical condition due to the large amount of corrosion. This has now been converted to S/S also.

It is better to use S/S pipe in original installations in locations close to water.

Figure 23. Hydraulic system on emergency gate.



Corrosion is common on submerged strong back connections. An alternative to consider would be to use stainless epoxy spelter sockets on the submerged ends, which would not corrode. Figure 24 shows Lockport Lock emergency gate corrosion on the spelter sockets. Note cables are 304 S/S.

Figure 24. Lockport Lock emergency gate corrosion photos.

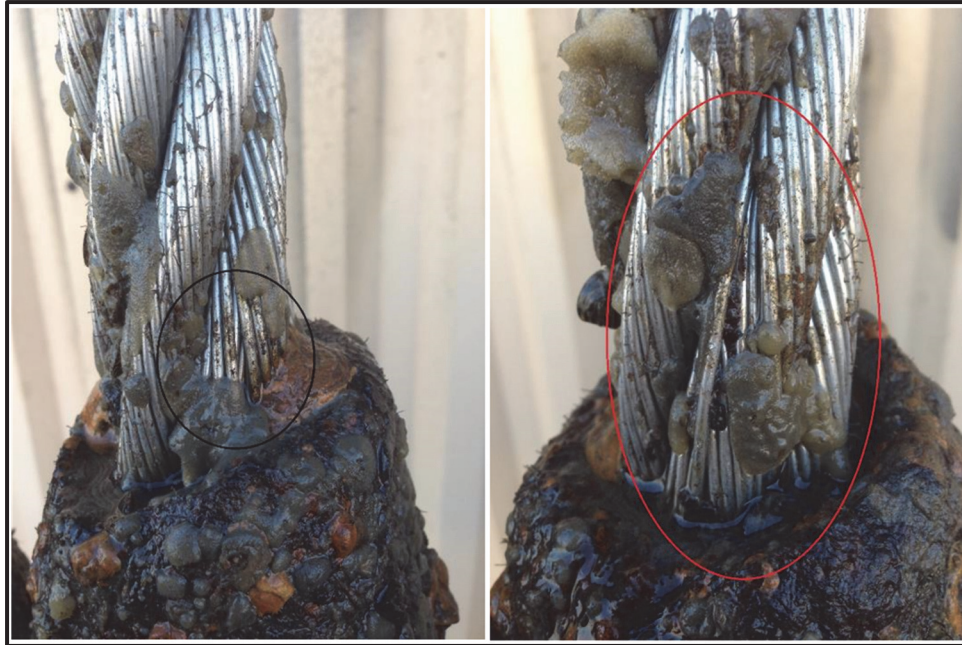

3.5 Mooring bits

In the past, lines would occasionally slip off the pin (especially lines from empty barges, which sit much higher in the water than loaded barges). Figure 25 shows the old mooring bit design. Figure 26 shows a new type of mooring bit that fixes these problems, but sharp edges were cutting lines. A key consideration when installing mooring bits is to specify contracts requiring manufacturer to grind-down sharp edges.

Figure 25. Old mooring bit.



Figure 26. New mooring bit.



3.6 Reusable lock nuts

Reusable lock nuts (Figure 27) are commonly used for couplings between the miter gate gearboxes and the drive gears. Alternatives include (1) single use locknuts grade 8, with a reduced head grade 8 bolt which is custom made, and (2) grade 8 nylock nuts with the longer Allen head grade 9 bolts. Nylock nuts require longer bolts because locking happens in extended top.

The problem with the use of non-reusable locknuts at Lockport Lock was that they would not stay secure when reused. This can become a critical item if too many of the old type of nuts become loose and the bolts drop out of the coupling. Lockport Lock decided to use the Nylock nuts instead and suggested to make Nylock nuts mandatory because they are reusable.

Figure 27. Non-reusable and reusable lock nuts.



3.7 High grade premixed coolant and synthetic oil

High grade premixed coolant (Figure 28) is good for 6 years. Premixed is recommended (mixing with well water can damage the radiator or engine).

Using high grade synthetic oil (Figure 29) for the generator may be better for the engine and only needs to be changed every 3-6 years instead of annually.

Figure 28. High grade premixed coolant.



Figure 29. High grade synthetic oil.



4 Accident and Failure Prevention

4.1 Limit switch failure

In 2014, the upper-left valve at Brandon Road Lock pushed out of the concrete (Figure 30). (This also happened twice at the Marseilles Lock in the summer of 2012.) This happens when a single closed limit switch fails, so that the valve travels too far in the downward (closing) direction until it hits bottom. The hydraulics' continued downward push turns into upward force that breaks the concrete anchors. To resolve the problem, the installation of second (or, redundant) closed limit switches were mandated at all the IWW locks. Starved Rock was the first lock gate site to implement the redundant switches. It is recommended that second redundant closed limit switches be mandated at all locks that have similar culvert valves.

Figure 30. Brandon Road Lock CLOSED limit switch failure.



4.2 Flushing accidents

There have been numerous incidents of flushing accidents damaging lock gates that have resulted in high costs for repairs. The following are the recommended steps to follow to avoid this type of accident from occurring:

1. Disallow flushing (opening upper valves to flush 1st cuts, debris, or ice), until all the conditions in step 2 are met. This should be Inland Marine Transportation System (IMTS)-mandated.
2. Note that PLC interlocks will not allow flushing unless lower gates are full-open and lower valves are full-closed. The interlocks force an operator to setup the flushing procedure correctly.
3. When finished, upper valves must be closed 5 minutes before PLC interlocks will allow downstream miter gates to be closed. This ensures that the water flow does not push the miter gates downstream. PLC programming is not included this extra “flushing protection” in the current IMTS interlock standards, but it should be considered for addition since almost all locks do periodic flushing.

Interlocks and 5-minute timers are intended to protect the lower gates from damage from the closing lower gates while the upper valves are still open or closing the lower gates before the flushing water has cleared the chamber. Before the upper “valve override” keyswitches will work, both lower gates must be full-open and in the recess, and both lower valves must be closed. Flushing does not work properly if the lower valves are open. Note that these should be called “flushing override” keyswitches. After flushing the first cut out and closing the upper valves, a 5-minute timer will “lock-out” the lower gates for 5 minutes. When the lower control stand “control power” light comes back on, the lower miter gates can be closed.

It is recommended that the content regarding the PLC programming be incorporated into the contracts. Contractors will be unwilling to do extra PLC programming without a contract modification. The flushing protection PLC programming should be in the IMTS interlock standards. Most Locks are currently flushing using their master override to bypass all of their interlocks. This should only be done by a supervisor. Some Locks still do not have keyswitches on their master override and should immediately install the keyswitches. Keys should be kept in the Lockmaster office key-box. At a very minimum, the master override keyswitch should still have G-V interlocks so lower gates cannot be closed while upper valves are still open.

This *minimum* fix (Figure 31) was done by John Pellerin at New Orleans District Locks after the 2009 Markland Lock miter gate calamity happened.

Figure 31. Minimum fix done at New Orleans District Locks after the 2009 Markland Lock miter gate calamity (fix protects lower miter gates in “interlock bypass” and normal modes).

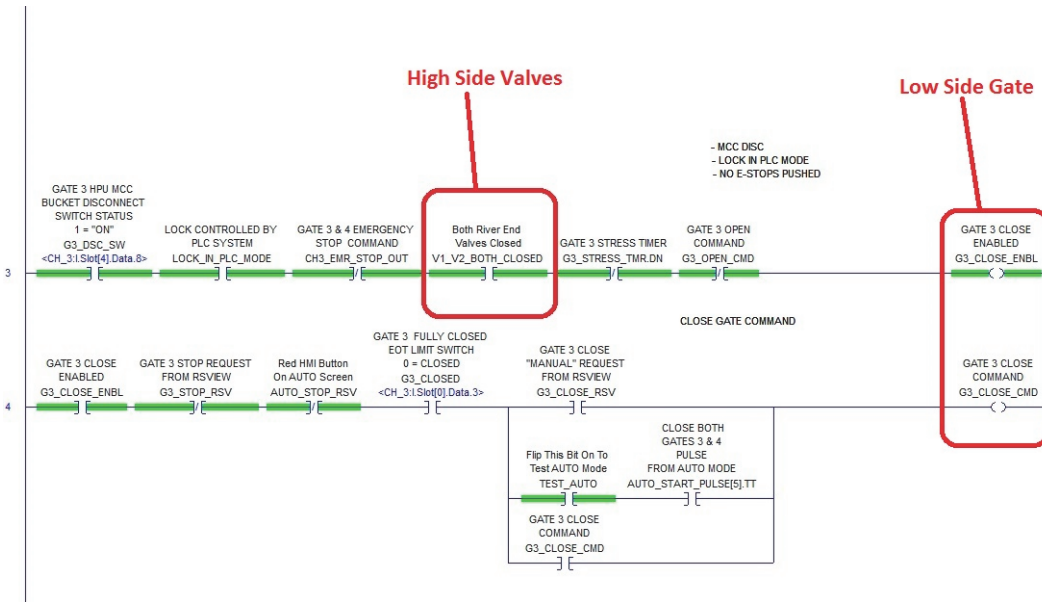

The 2009 Markland Lock miter gate calamity appears to have been a flushing accident. If the operator used master override to flush and forgot to return the master override to off/normal before closing the lower miter gates, that would be considered a flushing accident. Even if the operator was unaware one of the upper valves was still open, the normal G-V interlocks would have prevented closing the lower miter gates in that scenario.

According to Jeff Ross (Nashville District), the normal G-V interlocks that would have prevented the accident did not exist at the time of the accident. Therefore, there is an urgent need to make sure normal G-V interlocks are working to safely allow flushing and prevent excessive debris in lock chambers, such as that shown in Figure 32.

Figure 32. Debris at unknown lock gate.



Figure 33 shows a crack caused by a flushing accident at Lockport Lock. The repair crew had to replace the stem-bolt on the lower-right gate. The cracked plate on the lower-right gate was replaced by the repair crew in 2019.

Figure 33. Crack caused by flushing accident at Lockport Lock.



4.3 Miter gate hammering

Miter gate hammering results from chamber/tail water not being equalized. This problem is often caused by inattentive lock operators who open the gates against the lock chamber head pressure. The solution to this problem is:

1. PLC Programming – “three strikes and you’re out”
2. Engagement of limit switches in buffer box
3. When the green “Miter gate running” light blinks three times, the miter gates will be disabled for 3 minutes. This will force the operator to wait until the chamber/tail is equalized.

Note that gates without buffer boxes may have other hammering issues.

Alternate method: Redundant laser level gauges prevent opening miter gates under head pressure. This is used successfully in the New Orleans District.

4.4 Improper interlock settings

Interlocks should be set to prevent inadvertent errors in normal conditions. Temporary override of interlocks in unusual situation is to be expected. All lock operators should be informed when an interlock override is occurring; the override should be documented; and district personnel outside of the lock (at least) should be informed. A longer-term interlock override should be reviewed and approved by chain of command outside of lock personnel. This comes from lessons learned after the 2004 Mel Price Lock accident. The mitering proximity switch was left Forced (bypassed/overridden) in its PLC. Interlocks should be clearly documented and functionally tested on a recurring basis, possibly with periodic inspection. Accidents related to interlock overrides have the potential to be VERY serious.

The horn interlock is also something that should be mandatory at locks with vertical lift gates. The horn interlock disallows horn operation from upper control stands if either upper gate is not fully open or not closed. The problem is that there is no way to visually verify if either upper gate is full-open unless the operator looks at the status lights. While there are gate position indicators, these do not verify to the operator the full-open

position if he/she does not look at them. Horn being disabled is a clue to the operator that a gate is not full-open.

In March 2005, the Shift Chief on duty at Lockport Lock forgot to lower (open) the emergency gate the rest of the way after filling over it and pulled a first cut of barges into the emergency gate at full speed. After investigation, it was discovered that the gate was not full-open. Figure 34 shows the bent beam damage.

Figure 34. Lockport Lock emergency gate bent beam damage.



4.5 Improper attendance of tow haulage units

The old electronic tow haulage units had a problematic design flaw, which allowed operators to walk-away from the controls while the cable drum was still turning. This was the cause of many accidents, including an operator losing his thumb. The IWW decided to go with hydraulic tow haulage units (Figures 35 and 36), which have a spring-return “dead-man” safety feature. There have been multiple costly accidents due to operators leaving

controls unattended. A possible risk mitigation method would be to incorporate a motion switch that would time out if an operator walked away. Unsupervised operators have sometimes adopted this unsafe practice (Figure 36) that could also damage equipment (rope is used for bypassing spring-return “dead-man” safety feature).

Bungee-cords were used at Lockport Lock, and now all bypassings are prohibited.

Lock supervisors should not allow “dead-man” safety feature to be bypassed.

Figure 35. Hydraulic tow haulage unit at Peoria Lock.



Figure 36. Hydraulic tow haulage unit at Lockport Lock.



4.6 Lack of security cameras

There are currently cameras on the New Orleans District PLC network, which is a closed restricted network. Live video may be streamed using an ActiveX web browser built into the HMI screen. While these cameras have been used to assure a proper miter at a gate, their use obviously does not enhance security.

Nevertheless, it is important to have security cameras on site, both to monitor the work site and to help with accident investigation.

In 2007, a drunk driver at Lockport Lock damaged the keypads at a security gate (Figure 37). Camera footage would have helped the investigation of this accident. However, the use of wireless cameras is prohibited, and it would be expensive to run an optic fiber across the entirety of the bridge. A workable compromise might be to install a more economical standalone camera system, which would satisfactorily meet these basic needs. It may be beneficial to include a camera Digital Video Recorder recording of the gate mitering images in future contracts. A standalone camera system was

later installed, although wireless would be better for lock operators when towboat crew changes arrive during the night shift.

Figure 37. Bridge security gate damage at 16th Street.



4.7 Improper generator starting: use solid-state time-delay relay

It is important to have start-delay relays on generators to avoid the multitude of problems caused when the generator starts too soon, specifically, when the generator creates so much vacuum that the louvers cannot open. By starting early, the generator could overheat when the louvers are not able to open, which could potentially lead to serious problems. The timer at Lockport Lock is set to 10 seconds. The reader should avoid mechanical time-delay relays and use solid-state relays.

At Lockport Lock, the vacuum created during the incident prevented persons from leaving the building as the room filled with exhaust fumes. The generator would not shut down, even after using the emergency stop. The generator failed due to a circuit board failure, causing the run-away generator problem. Emergency fuel shutoff was identified.

At Winfield Locks and Dam, a similar incident occurred. The doors could not be opened due to the vacuum created. In this incident, water in the air

lines prevented the louvers from opening. This resulted in the generator overheating and blowing the head gasket on the generator. A serious issue.

It is recommended that a solid-state generator starting/cranking time-delay relay (Figure 38) be specified in U.S. Army Corps contracts to prevent this problem from happening. Specifically, mechanical time-delay relays should be avoided, as they wear out.

Figure 38. Generator solid-state time-delay relay at Lockport Lock.



4.8 Improper input module selection

Lockport Lock uses the PLC 5 series Advanced Micro Controls, Inc. (AMCI) resolver input modules. They are very reliable if properly grounded and protected with quality surge protection. Note that these input modules are also compatible with A/B Rockwell PLCs. It is recommended that contractors not be allowed to achieve false economies by sacrificing quality in this area in future upgrades.

At Marseilles Dam, local racks are used with the AMCI resolver input modules for each dam gate. This methodology is not very maintenance friendly when problems arise. This could be avoided by running the resolver cables into the building, but there are limitations on the distance resolver cables can be run. It varies according to the manufacturer model of the input module.

4.9 Misuse of master override keyswitch

In the past, incidents have occurred involving the misuse of the master override key switch. In 2010, a former Lockmaster at Lockport Lock turned the master override key switch and left it engaged without notifying anyone. Lock operators should be informed whenever something is bypassed.

It is suggested that, whenever used, all lock and dam master override key switches should log on to the PLC data logging system. The resulting collected data could be used for accident investigation. Lockport Lock later installed flashing amber warning lights in multiple locations, alerting operators when any key switch is selected to "OVERRIDE".

Note that, while the use of an override keyswitch may be a way to solve current problems in the short run, the overuse (or misuse) of the override keyswitch is likely to cause further problems in the long run. If not handled properly, unwise use of the override key switch could be a major safety concern. Keys should be kept securely in Lockmaster office keybox.

5 Lighting

Many of the installed light fixtures at lock gate sites provide inadequate lighting to various areas throughout the site. These lighting systems could benefit from upgrades.

5.1 High mast lighting

The most common lighting used to illuminate lock gate sites is high mast lighting (Figure 39). Two characteristics that determine the effectiveness of a lighting system are lighting distribution and brightness. Light distribution is just as important as the actual brightness (lumens) of the lights. Still, it has been noted that 1000W HID equivalent lumens are significantly better than 700W HID equivalent lumens. There needs to be a balance between the lighting fixture's distribution and brightness lumens.

Recommend doing a lighting study before LED lights are purchased or installed.

Note: Lockport Lock and Starved Rock Lock do not have high mast lighting.

At Lockport Lock upper guidewall, an LEDtronics cobra head was used to replace a broken Holophane cobra head. While the LEDtronics cobra head was brighter than the replaced light, its light distribution was not as good as that of the Holophane cobra head. Note that Lockport Lock had the same LEDtronic 400W High Pressure Sodium (HPS) fixture fail completely on the lower guide wall. This failure created a considerably more dangerous working area than did the failure of the Holophane cobra head on the upper guide wall because only half of the LED light bars stopped working on Holophane cobra head (had dual drivers).

Although the use of a Holophane #LEDGo84534KASG at Lockport Lock was found to provide excellent light distribution, the light was not bright enough for its application. It was determined that the LED lighting specification should be upgraded to require 5000K, which would provide a better and brighter type of LED light for this application. However, not all manufacturers provide a 5000K LED lighting fixture, as it is considered optional.

Fixtures were replaced with brighter 5000K and more lumens Holophane# ATB2 60BLEDE10 MVOLT R2 5K NR AO. Lighting is much better now.

Starved Rock Lock converted its light pole lighting to LED with impressive results. Light readings from the new LED lighting were 4-5 times higher than readings from the old light pole lighting. Six LEDtronics wall packs were installed on the Lockport Lock pump houses and cable buildings. They are friendly to navigation, as it is not too bright to look at. Figure 40 shows lighting at Starved Rock Lock before and after LED replacement.

Figure 39. High mast LED lighting at Winfield Locks and Dam.



Figure 40. Before (left) and after (right) LED replacement at Starved Rock.

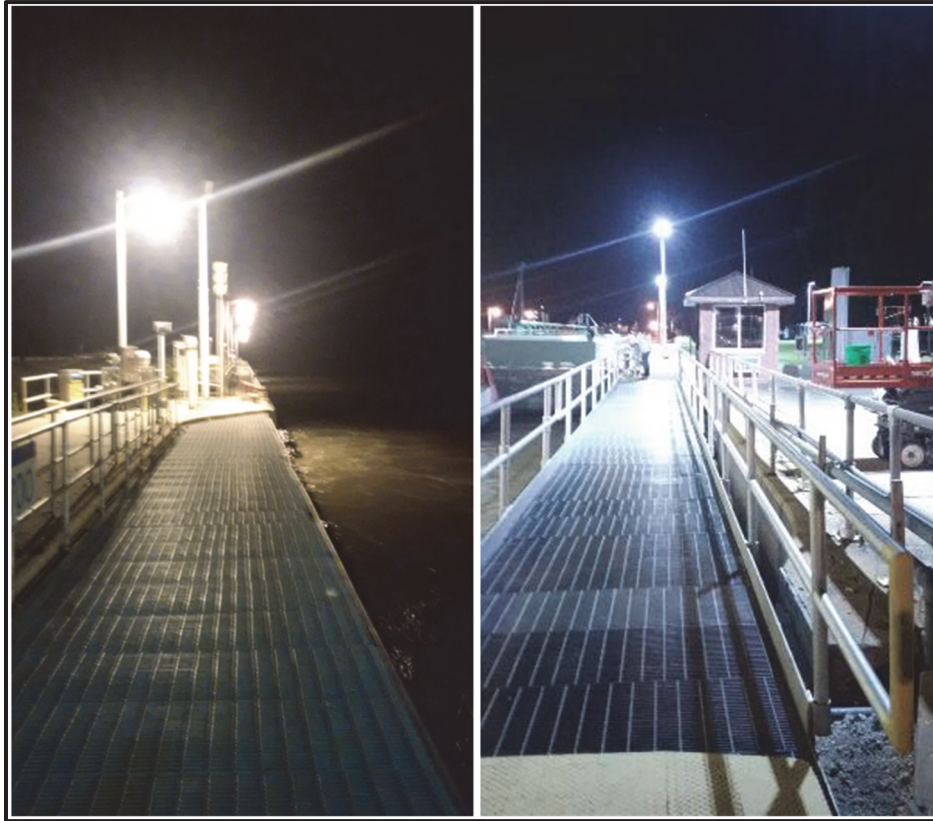

5.2 LED lighting fixture replacements

Lockport Lock had good results with the LEDtronics LED lighting product, except in the guide wall area, which used Holophane & LEDtronics cobra head lighting. LEDtronics light distribution determined to be insufficient at that location, so Holophane cobra head lighting was still the more preferred option for that application. Nevertheless, LEDtronics retrofits on the lock wall, provide a much higher light output, and use much less energy than HPS alternative. Figures 41 (LEDtronics floater light and wall pack) and 42 (LEDtronics retrofits) show LED lighting used at Lockport Lock.

Figure 41. LED lighting used at Lockport Lock.

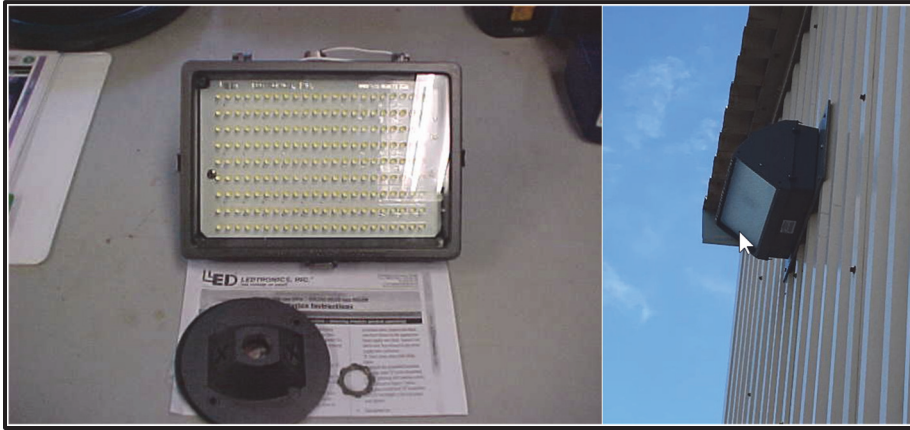

Figure 42. 480w LED retrofits at Lockport Lock.

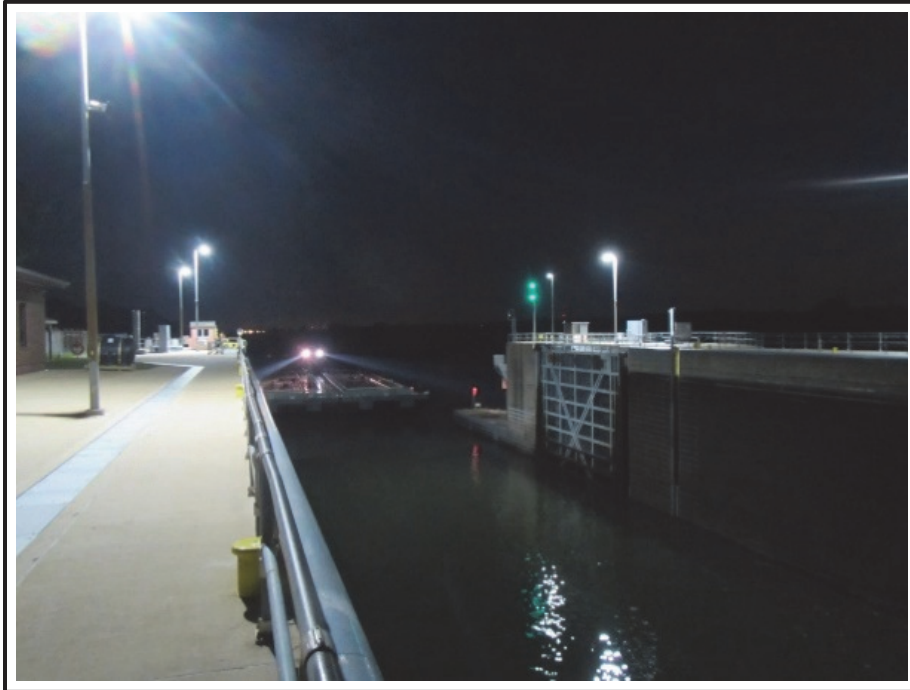
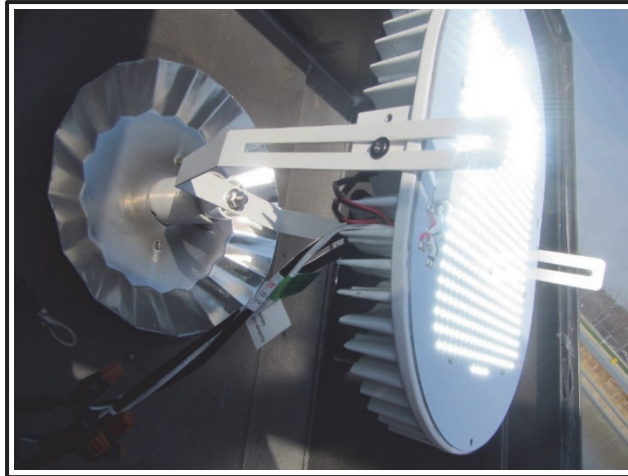

Figure 43 shows the installation of an LED lighting upgrade. The installation took about 3 weeks, and the total contract for supply and materials was just under \$8,900.

Figure 43. LED lighting upgrade at Lockport Lock.



The LED upgrade at Lockport Lock yielded greatest improvements in such critical areas as the tow haulage units (Figure 44). New LED fixtures also dramatically improved lighting at the lower miter gates, miter gate recesses, and operating machinery (Figures 45 and 46).

Figure 44. Tow haulage unit lighting at Lockport Lock.



Figure 45. Lower miter gates lighting improvement at Lockport Lock.



Figure 46. LEDtronics LED retrofit at Lockport Lock.



For building wall packs that do not face the river, Lockport Lock uses Lumark crosstour LED fixtures (Figure 47), which are less expensive than

LEDtronics units. LEDtronics wall packs face the river and are easier on eyes for tows.

Figure 47. Lumark Lockport cable building lighting.



5.3 Traffic lighting on river

Replacement LED traffic signals are brighter than the old incandescent signals. The conversion from incandescent to LED fixtures is easy and (so far) has caused no problems. The new LED fixtures are easy to install since they are designed to fit in the old light socket. Figures 48 and 49 show the traditional incandescent signals and the new LED lighting fixtures, respectively.

Figure 48. Traditional signal at upstream lock gate.



Figure 49. New LED light style fixture.

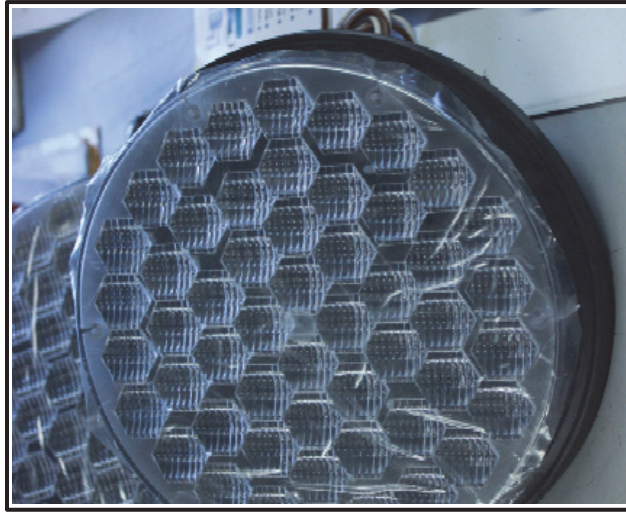

Control Panel LED light modules: Note that problems have been reported regarding the LED light modules in that the lights stay dimly lit when they are in the “off” state. This can confuse operators, who cannot always determine the status at a glance. Further investigation revealed that the problem can be fixed by using 6VAC transformer light modules and A/B 800T-N377x LED lamps. “X” is the color, (W, G, R, etc.). Specify color desired.

5.4 Light poles

At Lockport Lock, poles upgraded to LED (Figure 50) cannot be accessed for maintenance, except for one tip-down pole. Another issue that surfaced after the upgrade was that the 8-in. curb that previously protected the poles was not reinstalled as part of the levee rebuild. Since the pole was no longer well-protected, a visitor backed into the pole, knocked it down, and damaged the new LED light. As a result, the light pole, the light pole base, and the LED light had to be replaced.

Note that Lockport Lock engaged Holophane to perform a lighting study based on the height and spacing of the light poles to calculate the amount of light needed and to then choose an appropriate model for the situation. It is recommended that such studies be performed before installing LED fixtures.

Figure 50. Light pole at Lockport Lock.



6 Conclusions and Recommendations

6.1 Conclusions

There are many small things that can be done to significantly improve reliability of lock operating equipment. There are many lock sites around the country that are operating with equipment that is old and subject to upgrades. There should be national standards for many of the different equipment used at lock sites.

Operation safety can also be improved by making minor changes. Safety should be a priority at lock sites, and in order to minimize the risk of injury, different safety precautions may be taken to assure all machinery and equipment are up to proper standard.

6.2 Recommendations

6.2.1 Lock operating equipment

- *Encoders and Resolvers.* The use of resolvers, which are more reliable and better suited to convert the angular motion of the gate to an analog signal than optical encoders is recommended.
- *Gear Box Covers.* The use of gear box covers, which are essential to keep water and snow out of the gear box, is recommended.
- *Magnetic Proximity Switches and Mitering Cameras.* The use of magnetic proximity switches, which are more dependable than contact switches, is recommended. It is also recommended that a universal requirement be established to use magnetic proximity switches made by a manufacturer that offers the extended-range magnets. Use of mitering cameras (allows operator to verify mitering) is also recommended.
- *Redundant Closed Switches.* The use of redundant closed switches to stop the valve machinery from pushing-up out of the concrete if one switch fails, which oftentimes results in the breaking of the anchors, is recommended.
- *Cam-Operated Limit Switch Gearboxes.* After considering field experience with cam-operated limit switch gearboxes, it is recommended that bearings from Japan be ordered for use in these unit, as they are more reliable.
- *Overhead Monitors.* It is recommended that locations with control panel rooms in need of renovation consider installing overhead monitors as part of their control room renovation.

- *Pumps.* It is recommended that the smaller model hydraulic pumps (which use cartridges) are used on culvert valves.
- *Gate Mechanical Timers.* It is recommended that gate mechanical timers be replaced with solid-state timers.
- *Surge Protectors.* It is recommended that surge protection be included in the installation of any electronic instruments.

6.2.2 Maintenance improvements

- *Bumpers and Fenders.* It is recommended that bumpers and fenders be selected based on three prime considerations: frequency of replacement, cost of materials, and the costs and operational considerations associated with lock operation stoppage caused during periodic replacement.
- *Floating Mooring Bit Cathodic Protection.* Use of floating mooring bits with anode band cathodic protection, as appropriate, is recommended.
- *Hardened Steel.* The use of deep-hardened steel to replace worn valve wear tracks is recommended.
- *Corrosion.* The use of stainless steel connections (S/S epoxy spelter sockets) on submerged strong back connections is recommended.
- *Mooring Bits.* The use of improved mooring bit designs that prevent damage to towing industry lines and slippage off the pins is recommended. Sharp edges should be prohibited because they cut lines.
- *Reusable Lock Nuts.* It is recommended that use of reusable Nylock nuts be made mandatory for couplings between the miter gate gearboxes and the drive gears.
- *High Grade Anti-Freeze and Synthetic Oil.* Use of premixed extended-life coolant is recommended (lasts 6 years) and use of high-grade synthetic oil is recommended, since it reduces wear on engines and reduces oil change intervals dramatically.

6.2.3 Accident and failure prevention

- *Limit Switch Failure.* It is recommended that redundant closed limit switches be mandated at all locks that have culvert valves similar to those at Starved Rock Lock.
- *Flushing Accidents.* It is recommended that the content regarding the PLC programming be incorporated into the contracts so contractors can do extra PLC programming to prevent flushing accidents at lock gates. It is also recommended that flushing protection PLC programming be incorporated into IMTS interlock standards.

- *Miter Gate Hammering.* It is recommended that PLC programming be implemented to prevent conditions that result in miter gate hammering. An alternate method is to use redundant laser water level interlocks for opening miter gates. Displayed on HMI PC is also recommended.
- *Improper Interlock Settings.* It is recommended that all lock operators be informed whenever an interlock override is occurring, that all overrides be documented, and district personnel outside of the lock (at least) be informed. It is further recommended that all longer-term interlock overrides be reviewed and approved by chain of command outside of lock personnel, and that interlocks be clearly documented and functionally tested on a recurring basis, possibly with periodic inspection.
- *Improper Attendance of Tow Haulage Units.* It is recommended that motion switches be incorporated into electronic tow haulage units so the units will time out if the operator walks away from the controls. If operators insist on using ropes or bungee-cords to bypass spring-return safety on hydraulic tow haulage units, motion switches should be used. A “dead-man” safety feature should be mandatory on tow haulage units.
- *Lack of security cameras.* It is recommended that security cameras be installed onsite to monitor the work site and to help with accident investigation.
- *Improper Generator Starting: Use Solid-State Time-Delay Relay.* It is recommended that generator starting/cranking solid-state time-delay relay be specified in U.S. Army Corps contracts to prevent the problem of improper generator starting (starting too soon before vent louvers open). It is further recommended that mechanical time-delay relays be avoided, as they wear out.
- *Improper Input Module Selection.* It is recommended that, where they are used, PLC 5 resolver input modules be properly grounded and protected with quality surge protection.
- *Misuse of Master Override Keyswitch.* It is recommended that all lock and dam master override keyswitches be logged onto the PLC data logging system to allow resulting collected data to be used for accident investigation. Recommend keys be kept in Lockmaster office keybox.

6.2.4 Lighting

- *High Mast Lighting; LED Lighting Fixture Replacements; Traffic Lighting on River.* It is recommended that LED lighting be incorporated in Lock & Dam sites where lighting meets combined requirement for lighting distribution and brightness. Recommend dual drivers. Dual drivers offer safety advantages. Should be mandated for LED lighting.
- *Light Poles.* It is recommended that lighting studies based on the height and spacing of the light poles to calculate the amount of light (lumens) needed and to choose an appropriate model for the application be performed BEFORE purchasing/installing LED fixtures. **All** guidewall LED lighting should be minimum of 400w HPS equivalent.

References

AMCI (Advanced Micro controls, Inc.). Undated. *What is a Resolver?* Webpage. Terryville, CT: AMCI. <https://www.amci.com/industrial-automation-resources/plc-automation-tutorials/what-resolver/>

Headquarters, U.S. Army Corps of Engineers (HQUSACE). 2016. *Navigation*. Web page, <http://www.usace.army.mil/Missions/CivilWorks/Navigation.aspx>

Acronyms and Abbreviations

Term	Definition
AC	Alternating Current
AMCI	Advanced Micro Controls, Inc.
ANSI	American National Standards Institute
CERL	Construction Engineering Research Laboratory
DC	Direct Current
ERDC	U.S. Army Engineer Research and Development Center
ERDC-CERL	Engineer Research and Development Center, Construction Engineering Research Laboratory
HMI	Human Machine Interface
HPS	High Pressure Sodium
I/O	Input/Output
IMTS	Inland Marine Transportation System
IWW	Illinois Waterway
LED	Light Emitting Diode
NSN	National Supply Number
OMB	Office of Management and Budget
PLC	Programmable Logic Controller
SAR	Same As Report
TR	Technical Report
USACE	U.S. Army Corps of Engineers

REPORT DOCUMENTATION PAGE

Form Approved
OMB No. 0704-0188

Public reporting burden for this collection of information is estimated to average 1 hour per response, including the time for reviewing instructions, searching existing data sources, gathering and maintaining the data needed, and completing and reviewing this collection of information. Send comments regarding this burden estimate or any other aspect of this collection of information, including suggestions for reducing this burden to Department of Defense, Washington Headquarters Services, Directorate for Information Operations and Reports (0704-0188), 1215 Jefferson Davis Highway, Suite 1204, Arlington, VA 22202-4302. Respondents should be aware that notwithstanding any other provision of law, no person shall be subject to any penalty for failing to comply with a collection of information if it does not display a currently valid OMB control number. PLEASE DO NOT RETURN YOUR FORM TO THE ABOVE ADDRESS.

1. REPORT DATE (DD-MM-YYYY) April 2021			2. REPORT TYPE Technical Report		3. DATES COVERED (From - To)	
4. TITLE AND SUBTITLE Lock Operation Improvements					5a. CONTRACT NUMBER	
					5b. GRANT NUMBER	
					5c. PROGRAM ELEMENT	
6. AUTHOR(S) Stuart D. Foltz and Daniel E. Hooks					5d. PROJECT NUMBER 611102AH68	
					5e. TASK NUMBER	
					5f. WORK UNIT NUMBER	
7. PERFORMING ORGANIZATION NAME(S) AND ADDRESS(ES) U.S. Army Engineer Research and Development Center (ERDC) Construction Engineering Research Laboratory (CERL) PO Box 9005, Champaign, IL 61826-9005					8. PERFORMING ORGANIZATION REPORT NUMBER ERDC/CERL TR-21-14	
9. SPONSORING / MONITORING AGENCY NAME(S) AND ADDRESS(ES) Headquarters, U.S. Army Corps of Engineers (HQUSACE) 441 G St., NW Washington, DC 20314-1000					10. SPONSOR/MONITOR'S ACRONYM(S) CEERD-HT	
					11. SPONSOR/MONITOR'S REPORT NUMBER(S)	
12. DISTRIBUTION / AVAILABILITY STATEMENT Approved for public release; distribution unlimited.						
13. SUPPLEMENTARY NOTES Under Work Units L93CJ7 and 4B1176						
14. ABSTRACT The U.S. Army Corps of Engineers (USACE) owns or operates 236 locks at 191 sites (HQUSACE 2016). Although the locks at these sites generally perform reliably, more than half of these structures have surpassed their 50-year economic design life and as such, there are increasing concerns about their continued safe, reliable operation. This work was undertaken to review lock operating equipment, maintenance practices, records pertaining to accidents and equipment failures, and lighting systems; to identify alternative improvements to equipment and equipment maintenance practices; and to analyze and compare those alternatives to determine and recommend optimal solutions. This report documents some lessons learned, primarily to share information that others might find useful. Note that the recommendations in this report should not be viewed as policy, although some might be considered by those creating policy.						
15. SUBJECT TERMS Locks (Hydraulic engineering)--Maintenance and repair, Locks (Hydraulic engineering)--Equipment and supplies, Dams--Construction Hydraulic structures--Design and construction.						
16. SECURITY CLASSIFICATION OF:			17. LIMITATION OF ABSTRACT SAR	18. NUMBER OF PAGES 61	19a. NAME OF RESPONSIBLE PERSON	
a. REPORT Unclassified	b. ABSTRACT Unclassified	c. THIS PAGE Unclassified			19b. TELEPHONE NUMBER (include area code)	