



DEPARTMENT OF THE NAVY

OFFICE OF COUNSEL
NAVAL UNDERSEA WARFARE CENTER DIVISION
1176 HOWELL STREET NEWPORT RI 02841-1708

IN REPLY REFER TO

Attorney Docket No. 112193
19 July 2021

The below identified patent application is available for licensing. Requests for information should be addressed to:

TECHNOLOGY PARTNERSHIP OFFICE
NAVAL UNDERSEA WARFARE CENTER
1176 HOWELL ST.
CODE 00T2, BLDG. 102T
NEWPORT, RI 02841

Serial Number 17/313,218
Filing Date 6 May 2021
Inventor Paul V. Cavallaro

Address any questions concerning this matter to the Technology Partnership Office at (401) 832-3339.

DISTRIBUTION STATEMENT
Approved for Public Release
Distribution is unlimited

SOFT-TO-HARD GOODS CONNECTIONS WITH DYNAMIC ENERGY DISSIPATION

STATEMENT OF GOVERNMENT INTEREST

[0001] The invention described herein was made in the performance of official duties by employees of the U.S. Department of the Navy and may be manufactured, used, or licensed by or for the Government of the United States for any governmental purpose without payment of any royalties thereon.

CROSS REFERENCE TO OTHER PATENT APPLICATIONS

[0002] None.

BACKGROUND OF THE INVENTION

1) Field of the Invention

[0003] The present invention is directed to connections for joining inflatable structures to rigid structures.

2) Description of the Prior Art

[0004] Known as soft-to-hard goods connections to those skilled in the art; these load-carrying structural joints require consideration of the elastic stiffness imbalances that exist between soft and rigid components as well as their relative motions when assembled. Furthermore, rigid components can transfer bending moments while inflatable components are made from thin flexible skins such as fabrics or sheet films that

behave as membranes. Membranes do not possess bending and in-plane compression stiffnesses and therefore cannot transfer bending moments or in-plane compressive stresses.

[0005] Present connections operate with viscoelastic behaviors with an operational strain range of 0.01%-50.0% and a frequency range of 0.0 Hz to 5.0 KHz. Strains from externally applied loads are typically fully recoverable after removing the loads.

[0006] The skins of inflatable fabric structures are often made from textiles containing yarns spun from high performance fibers such as polyesters, aramids, liquid crystal polymers and hybridized yarns. The yarns are arranged in specific fabric architectures depending on the form factor of the inflatable component and the desired mechanical behavior when the component is inflated and subjected to external loads.

[0007] If the inflatable component does not contain a separate internal bladder; the fabrics are laminated with one or more layers of elastomeric material to provide an impermeable membrane. The membrane contains the internal pressurization media in a closed volume while preserving the ability of the inflatable components to achieve compact form factors when deflated. If internal bladders are required and depending upon the desired mechanical behaviors of the inflatable components; the fabrics may still be laminated for environmental protection

(i.e., wear, abrasion, puncture, ultra-violet light etc.) to the fibers. The pressurization media can be gas or a liquid.

[0008] The fiber and lamination layers are generally polymers that provide material damping. However, energy dissipation capacities beyond those attainable with polymer skin materials alone is generally insufficient for attenuating dynamic energies when the soft-to-hard goods connections are subjected to sea-state motions, wave slap, wind, mechanical shock and blast loading events. Additional energy dissipation sources are necessary and require additional localized devices or mechanisms (referred to as system damping) to minimize peak dynamic reaction forces to acceptable ranges in order to avoid the failure of the soft-to-hard goods connections.

SUMMARY OF THE INVENTION

[0009] The present invention discloses a structurally robust, deployable, and removable connection for mechanically joining inflatable soft structures to rigid host structures by using receivers having path geometries configured to accept and physically secure one or more chorded elements extending from the inflatable structure.

[0010] Further advantages of the present invention are peel stress mitigation and the positive locking benefits achieved by the nested designs, the shock isolation, damping, and friction

dissipation performances of the viscoelastic receivers for mitigating reaction forces from dynamic and cyclic loading events. The inventive connection enables the removal of the inflatable structure from the rigid host structure.

[0011] The soft-to-hard goods connector includes an elastomeric bladder with a preform layer and an outer textile layer enclosing the preform layer. The outer textile layer includes skin extension layers extending beyond a periphery of the elastomeric bladder. The connector includes a rigid host structure having a receiving component.

[0012] The skin extension layers have a chord attached at a distal end of the extension layers. The receiving component has a mounting track with the chord mounted in the mounting track. The receiving component permits the chord to rotate about a longitudinal axis with a limited range of motion.

[0013] According to another embodiment of the invention, a mechanical locking device for soft-to-hard connections includes a rigid structure and a receiving component connected to the structure. The receiving component includes a mounting track in the receiving component. The chord is removably engaged with the mounting track. The diameter of the chord is oversized with respect to the opening of the mounting track.

[0014] The present invention provides novel connections: for use in joining inflatable structures to rigid structures; to

optimize stiffnesses and load transfer paths across the connections; and includes energy dissipation and shock mitigation mechanisms necessary to support a variety of dynamic loading conditions.

BRIEF DESCRIPTION OF THE DRAWINGS

[0015] Other objects, features and advantages of the present invention will become apparent upon reference to the following description of the preferred embodiments and to the drawings, wherein corresponding reference characters indicate corresponding parts throughout the several views of the drawings and wherein:

[0016] **FIG. 1** is a cut-away view of a soft body package of the present invention;

[0017] **FIG. 2** is a cut-away view of a chord with a fabric skin extension layer of the soft body package;

[0018] **FIG. 3** is a cut-away view of a preform layer of the soft body package;

[0019] **FIG. 4** is a cut-away view of a hard body portion of the present invention;

[0020] **FIG. 5** is a side view of a single-chorded connection;

[0021] **FIG. 6** is a side view of a double-chorded connection;

[0022] **FIG. 7** is a side view of the single-chorded connection under load;

[0023] **FIG. 8** is a side view of a double-chorded connection under load;

[0024] **FIG. 9** is a side view of a nested single-chorded connection;

[0025] **FIG. 10** is a side view of a nested double-chorded connection;

[0026] **FIG. 11** is a side view of a double-chorded connection in a viscoelastic receiver;

[0027] **FIG. 12** is a side view of a nested double-chorded connection in a viscoelastic receiver; and

[0028] **FIG. 13** is a graph of reaction force.

DETAILED DESCRIPTION OF THE INVENTION

[0029] Referring to the drawings, **FIG. 1** depicts an elastomeric bladder **100**. The elastomeric bladder **100** includes a preform layer **102** having an outer textile strength layer **104**. A plurality of skin extension layers **106** extend beyond a periphery of the elastomeric bladder **100**. The skin extension layers **106** have a chord **108** attached at a distal end of the skin extension layers. The chord **108** is perpendicular to the skin extension layers **106**.

[0030] **FIG. 2** depicts an enlarged view of the skin extension layer **106**. The skin extension layer **106** is made from fabrics, composites, or other structural materials. Typically, the skin

extension layer **106** is a fabric piece attached to the outer textile strength layer **104**. The chord **108** is constructed of polymer cordage, but the chord can also be a metal wire cable, polymer rod, or other material. In use, the skin extension layer **106** wraps around the chord **108** and an overlap region **110** is stitched, bonded, RF-welded, riveted or otherwise fastened back to the skin extension layer.

[0031] Referring to **FIG. 3**, the preform layer **102** may be made of a drop stitch fabric that is woven with a complex weaving process. For example, the preform layer **102** includes a top panel **112** and a bottom panel **114**. Each of the top panel **112** and the bottom panel **114** is made of a woven fabric with a plurality of drop yarns **116** periodically and alternately dropped between the top panel and the bottom panel; thereby, creating an offset distance " h " between the top panel and the bottom panel. The preform layer **102** has the outer textile strength layer **104** laminated external to the top panel **112** and the bottom panel **114**. As shown in **FIG. 1**, the preform layer **102** is sealed along the edges and configured to enclose a pressurized medium such as air to create flat planar shapes upon inflation. Such a preform layer **102** behaves as a structural sandwich panel subject to bending loads.

[0032] **FIG. 4** depicts a cut-away view of a rigid structure **118**. The rigid structure **118** includes a receiving component **120**. The

receiving component **120** provides a rigid interface to join the elastomeric bladder **100** to the rigid structure **118**. The rigid structure **118** and the receiving component **120** allow for installation and removal of the elastomeric bladder **100** when not inflated to/from the structure.

[0033] The receiving component **120** has a mounting track **122**. The mounting track **122** is a hollow channel within the receiving component **120** and is substantially circular in cross-section. For complex 3-D geometries of the rigid structure **118**, the cross section of the receiving component **120** may be swept along a straight or curvilinear path depending upon the shape and orientation requirements of the rigid structure. The receiving component **120** has an opening or locking groove **124** that extends to the mounting track **122**. The chord **108** is removably engaged with the mounting track **122**. The opening **124** permits the chord **108** to rotate about a longitudinal axis of the chord with a limited range of motion. The diameter of the chord **108** is oversized with respect to the opening **124** that extends into the mounting track **122** such that an interference fit is formed against an open side **126** of the mounting track.

[0034] **FIG. 5** depicts a side view of a single-chorded connection of an elastomeric bladder **100** to the rigid structure **118**. In the figure, the upper and lower skin extension layers **106** connect to a single chord **108** on each end of the elastomeric

bladder **100**. The chord **108** is secured within the mounting track **122** by the interference fit against the side **126** of the mounting track but can rotate with a limited range of angular motion.

[0035] FIG. 6 depicts a double-chorded connection of the elastomeric bladder **100** to a host rigid structure **127**. In the figure, first and second skin extension layers each connect to separate chords. A first chord **128** attaches at a distal end of a first skin extension layer **130** extending from a top **132** of the elastomeric bladder **100**. A second chord **134** attaches at a distal end of a second skin extension layer **136** extending from a bottom **138** of the elastomeric bladder.

[0036] The host rigid structure **127** includes a receiving component **139**. The receiving component **139** is a rigid interface to join the elastomeric bladder **100** to the rigid structure **127**. The receiving component **139** has a first mounting track **140** and a second mounting track **142**. The first mounting track **140** is vertically aligned with the second mounting track **142**. As in **FIG. 5**, both the first mounting track **140** and the second mounting track **142** are hollow channels within the receiving component **139** and are substantially circular in cross-section. Each of the first chord **128** and the second chord **134** can be removably engaged with the respective first mounting track **140** and second mounting track **142**. The receiving component **139** has gap openings **144**, **146** that extend to the first mounting track

140 and the second mounting track **142**, respectively. The gap openings **144**, **146** permit the first chord **128** and the second chord **134** to rotate about a longitudinal axis with a limited range of motion.

[0037] The diameter of the first chord **128** and the second chord **134** may be the same. Each diameter is oversized with respect to the openings **144**, **146** such that an interference fit forms for the first chord **128** and the second chord **134** against the open side **126** of the respective first mounting track **140** and second mounting track **142**. The first chord **128** and the second chord **134** secure within the first mounting track **140** and second mounting track **142**, respectively, of the receiving component **139** but are free to rotate within the respective first mounting track **140** and second mounting track **142** with a limited range of angular motion.

[0038] The receiving component **139** may be machined, 3-D printed, extruded, pultruded, cast, etc. from a variety of materials including metals, plastics, composites, etc. For complex 3-D geometries, the X-Y cross sections of the receiving component **139** may be swept along straight or curvilinear paths depending upon the shape and orientation requirements of the host rigid structure **127** to form mounting tracks that can be continuous or discontinuous.

[0039] Referring again to **FIG. 3**, the woven top panel **112** and the bottom panel **114** of the preform layer **102** complete the same function as the metal skins of a sandwich panel by providing resistance to bending and in-plane tension loads. The air-inflated volume of the preform layer **102** using such a drop stitch panel together with the transverse fibers (i.e., the drop yarns **116**) positioned between the top panel **112** and the bottom panel **114** behave as the core of a rigid sandwich panel to resist transverse shear loads while maintaining the separation distance, h , between the mid-planes of the layers of the top panel and the bottom panel.

[0040] The bending and shearing stiffnesses of the inflated preform layer **102** are functions of internal pressure " P_i ", separation distance " h ", and the elastic modulus of the fabric skins " E_{fabric} ". The E_{fabric} corresponds to the elastic modulus of the fabric about the pretensioned (inflated) state and is generally nonlinear with pressure. The fabric skins can only support in-plane tension stresses. However, the fabric skins have the capacity to support externally applied in-plane compression loads if the pretensions developed in the fabric skins are sufficient to offset the applied in-plane compression loads. Once the superposition of the externally applied compression loads and pretensions from inflation results in a net zero stress state; the onset of wrinkling has occurred and

the inflatable structure begins to lose stiffness upon further loading.

[0041] The effective transverse shear stiffness " G_t ", of an inflated preform layer **102** subject to bending loads is dependent on P_i but is not a material property. The effective transverse shear stiffness is a system property resulting from the thermodynamic behavior of the enclosed air. A fixed mass of air in the presence of transverse shearing deformations will experience a reduction in volume leading to an increase in P_i . This leads to thermodynamic work done on the air known as " PV work" as calculated by Equation **(1)**. Prior research has shown that for air-inflated drop stitch panels subjected to bending and transverse shear stresses; G_t is an order of magnitude greater than P_i .

$$PV_{work} = \int_1^2 PdV + \int_1^2 VdP \quad (1)$$

where subscript 1 and superscript 2 represent the inflated and externally loaded states, respectively. P is the internal pressure of the air and V is the volume of air.

[0042] The energy balance that must be satisfied for the air-inflated drop stitch panel (preform layer **102**) going from the inflated state-1 to an externally loaded static bending state-2 is given by Equation **(2)**:

$$Work_{Done} = \int_1^2 F \delta = \Delta E_{internal} = \Delta E_{strain} + \int_1^2 PdV + \int_1^2 VdP + \Delta E_{dissipation} \quad (2)$$

where " $Work_{Done}$ " is the total work done on the drop stitch panel; " δ " is the displacement along the direction of an applied force " F "; " $\Delta E_{internal}$ " is the change in internal energy from inflated state-1 to the loaded state-2; " ΔE_{strain} " is the change in strain energy from inflated state-1 to the loaded state-2; and " $\Delta E_{dissipation}$ " is the energy dissipated from inflated state-1 to the loaded state-2.

[0043] Increasing the separation distance h between midplanes of the top panel **112** and the bottom panel **114** is effective for increasing the bending stiffness of the drop stitch panel, noted as " $E_{fabric}I$ " and is achieved by the third term in the brackets of Equation (3). This term results from the Parallel Axis Theorem which computes the second area moment of inertia " I " of the separated arrangement of the drop stitch panel skins according to the bracketed term:

$$E_{fabric} I = E_{fabric} \left[\frac{b t_{upper_skin}^3}{12} + \frac{b t_{lower_skin}^3}{12} + A h^2 \right] \quad (3)$$

where " $E_{fabric} I$ " is the bending stiffness (product of E_{fabric} and I) of the panel; " b " is the width of the panel; " t_{upper_skin} " and " t_{lower_skin} " are the upper and lower fabric skin thicknesses,

respectively; and "A" is the sum of the upper and lower fabric skin cross sectional areas.

[0044] It is important to note that E_{fabric} is often nonlinear with inflation pressure and is a function of the ratio of biaxial tensions along the warp and weft axes of the top panel **112** and the bottom panel **114**.

[0045] Load-carrying connections between a drop stitch panel and a rigid structure are ideally constructed when the skin mid-plane separation distance h , is preserved across the connections. This maximizes the load transferred from the panel to the rigid structure and minimizes the bending deflection of the drop stitch panel.

[0046] **FIG. 7** and **FIG. 8** depict soft-to-hard goods connections for the inflated elastomeric bladder **100** subject to a distributed bending load " $P(x)$ ". In **FIG. 7**, both connections are configured with chords **108** attached to skin extension layers **106** affixed to the top panel **112** and the bottom panel **114** and receiving components **120** attached to the host rigid structure **118**. The receiving components **120** are rigid interfaces that join the inflated elastomeric bladder **100** to the rigid structure **118** (not shown to avoid clutter). The receiving components **120** allow for installation and removal of the elastomeric bladder **100** when not inflated to/from the rigid structure **118**. The receiving components **120** permit the chords **108** to rotate about

the longitudinal axes of the chords with a limited range of motion.

[0047] The chords **108** are secured within the mounting tracks **122** of the receiving component **120** but are free to rotate within the mounting tracks with a limited range of angular motion. The chords **108** can only transfer tensile forces between the elastomeric bladder **100** and the host rigid structure **118** (i.e., bending moments cannot be transferred) if the skin extension layers **106** are membranes. Otherwise, compression and bending loads can also transfer from the skin extension layers **106** to the receiving components **120**.

[0048] The diameter of the chord **108** is oversized with respect to the opening of the mounting track **122** such that an interference fit is formed. In **FIG. 7**, a single chord design is shown whereby skin extension layers **106** from both the top panel **112** and the bottom panel **114** connect to a single chord **108** on each end of the elastomeric bladder **100** that is connected to a host rigid structure **118**.

[0049] In **FIG. 8**, a double-chord design has a skin extension layer **106** from the top panel **112** and the bottom panel **114** connected to separate chords at each end of the elastomeric bladder **100**. The double-chord arrangement maintains the mid-plane separation distance, h , across the connection. The top panel **112** of the single-chord arrangement shown in **FIG. 7** does

not develop tension until after the elastomeric bladder **100** deflects below the elevation of the single-chord connection while the bottom panel **114** develops tension immediately upon loading. This results in a nonlinear load-deflection behavior of the elastomeric bladder **100**. The lower skin tension T_L always exceeds the upper skin tension T_U provided both skin extension layers **106** are of the same material and thickness.

[0050] **FIG. 9** and **FIG. 10** depict alternative designs of the single-chord and double-chord connections to provide additional securing performance against transverse loadings. The receiving component **120** in **FIG. 9** and the receiving component **139** in **FIG. 10** include a concave surface **148**. At least a portion of the periphery of the elastomeric bladder **100** (i.e., the outer edges) can nest within the concave surface **148** of the receiving components **120**, **139**.

[0051] Nesting is a simple mechanism that offers additional positive-locking performance which increases with increasing inflation pressure. However, care must be taken to ensure that the spacing " L_s " between opposite connections does not restrict the lateral extensibility of the elastomeric bladder **100** during inflation; otherwise, the elastomeric bladder may not fully develop the maximum skin tensions achievable for the desired inflation pressure. The nested connection shown in **FIG. 9** and **FIG. 10** reduces the rotation and deflections of the elastomeric

bladder **100** and eliminates the possibility for delamination failures resulting from peel stress effects.

[0052] In another embodiment, the material of the receiving components **120**, **139** can be selected to create additional damping beyond that achieved by the inflatable fabric structure material. For example, the receiving components **120**, **139** can be made using viscoelastic materials (i.e., rubber, thermoplastic urethane (TPU), polyurea, etc.) having appreciable damping and rate-dependent and frequency-dependent mechanical properties.

[0053] The receiving components **120**, **139** can be tuned to provide additional energy dissipation sources as needed to reduce peak reaction forces at the connections; the benefits of which will be of foremost value for inflatable structures subject to dynamic and cyclic loads. The frequency-dependent viscoelastic properties of the receiving component **120** can be leveraged to alter the dynamic modal behaviors of the elastomeric bladder **100**. For a viscoelastic solid subjected to the harmonic shearing function of Equation **(4)**; the material stiffness properties are governed by the storage modulus in shear, G' , and the damping performance is governed by the loss modulus in shear, G'' .

$$\gamma(t) = \gamma_0 \sin \omega t \quad (4)$$

where: " $\gamma(t)$ " is the shearing strain at time t ; " γ_0 " is the amplitude of the shearing strain; and " ω " is the frequency of loading in radians/sec.

[0054] The storage and loss moduli are related by the linear viscoelastic stress-strain law of Equation (5).

$$\sigma(t) = \gamma_0 [G'(\omega) \sin(\omega t) + G''(\omega) \cos(\omega t)] \quad (5)$$

where " $\sigma(t)$ " is the stress at time " t ".

[0055] The loss angle is defined by $\phi = \tan^{-1} (G'' / G')$. The complex modulus, G^* combines the storage and loss moduli in shear as shown by Equation (6):

$$G^* = G' + i G'' \quad (6)$$

[0056] When subject to dynamic and fatigue loads, the work done on the system is converted to a combination of strain energy and heat with the latter being a form of energy dissipation through hysteresis. The energy dissipated per loading cycle and unit volume of material is equal to the area in the hysteresis loop.

[0057] For a viscoelastic material subject to cyclic pure shear, the energy dissipated per unit volume per cycle is given by Equation (7):

$$D = \int_0^{2\pi\omega} \sigma \left(\frac{d\gamma}{dt} \right) dt \quad (7)$$

[0058] Using Equation (4) and Equation (5); the dissipated energy "D" can be expressed as shown by Equation (8):

$$D = \int_0^{2\pi\omega} \gamma_0^2 \omega (G' \sin \omega t + G'' \cos \omega t) \cos \omega t dt \quad (8)$$

which reduces to Equation (9):

$$D = \pi \gamma_0^2 G''(\omega) \quad (9)$$

[0059] FIG. 11 shows an offset double-chorded connection incorporating a viscoelastic receiver 150 partially encased in the rigid enclosure 127 and FIG. 12 shows a nested double-chorded connection incorporating a viscoelastic receiver 150 partially encased in the rigid enclosure 127. The viscoelastic receivers 150 are partially encased in a rigid enclosure (structural shell) 127 to contain the viscoelastic material. This permits finite relative motions of the chords 130, 136 and the viscoelastic receivers 150 contained within the rigid enclosures 127. A further energy dissipation source may be included by adding cutout features, such as slotted apertures 152 or holes (slots) in the viscoelastic receivers 150. The slotted apertures 152 serve to selectively control the stiffness of the receiver 150; to promote finite relative motions; and to produce contacting surfaces within the viscoelastic material in order to maximize energy dissipation through friction.

[0060] Consider the behavior of a viscoelastic receiver connection with material softening subject to a mechanical shock loading event. **FIG. 13** is a graph showing a comparison of reaction forces for rigid and viscoelastic receivers subject to mechanical shock load. The relative compliance and viscoelastic softening of the receiver **150** reduces the peak reaction force by extending the time duration of loading.

[0061] The advantages and new features achieved by the present invention include structurally robust, deployable and removable connection designs for mechanically joining inflatable soft structures such as drop stitch fabric panels to rigid host structures using continuous or discontinuous rigid or viscoelastic receivers having linear or curvilinear longitudinal path geometries configured to accept and physically secure one or more chorded elements extending from the inflatable structure. Further advantages of these designs are the peel stress mitigation and positive locking benefits achieved by the nested designs, the shock isolation, damping, and friction dissipation performances of the viscoelastic receivers for mitigating reaction forces from dynamic and cyclic loading events including sea state motions, wave slap, wind, vibration, mechanical shock, blast overpressure, etc. The inventive connection designs enable the removal of the inflatable

structure from the rigid host structure and allow the inflatable structure to be stowed in a compact form factor when not in use.

[0062] It will be understood that many additional changes in the details, materials, steps and arrangement of parts, which have been herein described and illustrated in order to explain the nature of the invention, may be made by those skilled in the art within the principle and scope of the invention as expressed in the appended claims.

SOFT-TO-HARD GOODS CONNECTIONS WITH DYNAMIC ENERGY DISSIPATION

ABSTRACT OF THE DISCLOSURE

A soft-to-hard goods connector is provided which includes an elastomeric bladder having a preform layer and an outer textile layer enclosing the preform layer. The outer textile layer has at least one skin extension layer extending beyond a periphery of the elastomeric bladder. The skin extension layer has a chord attached at a distal end with the chord being perpendicular to the skin extension layer. The connector includes a host rigid structure with a receiving component. The receiving component has a mounting track with the chord mounted in the mounting track. The receiving component permits the chord to rotate about a longitudinal axis of the chord with a limited range of motion.

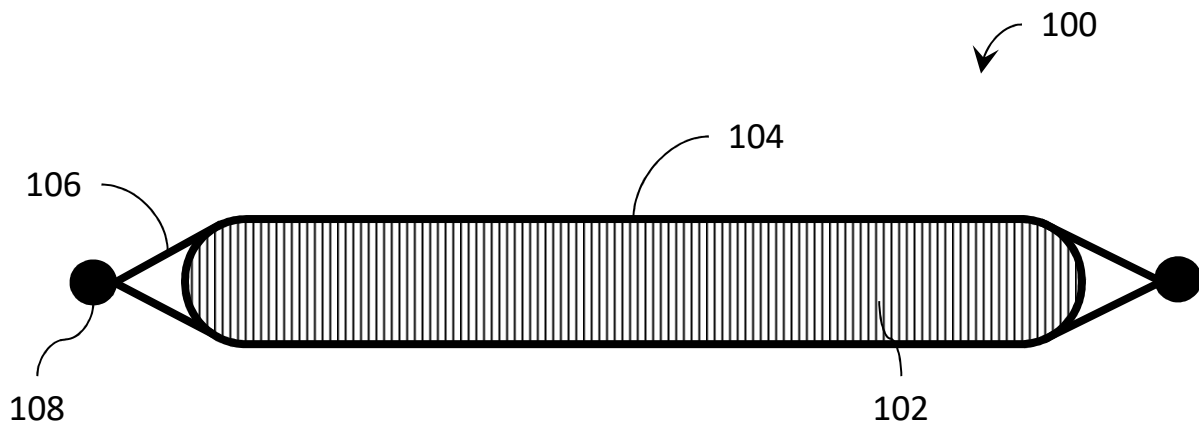

FIG. 1

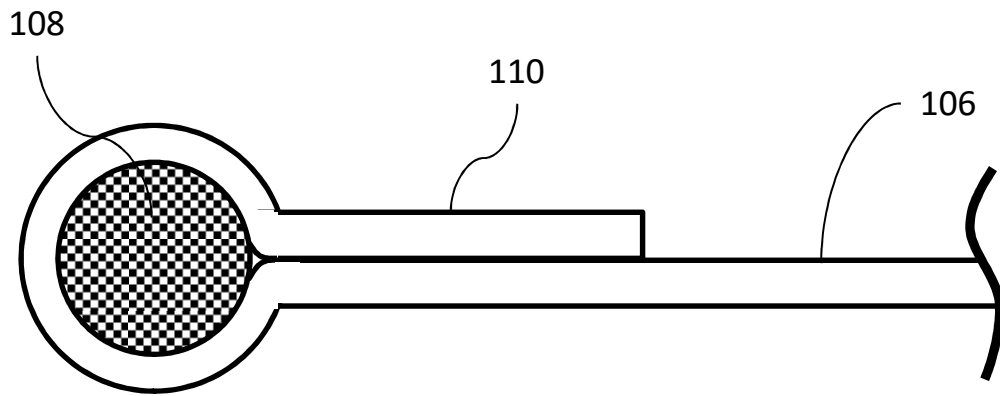

FIG. 2

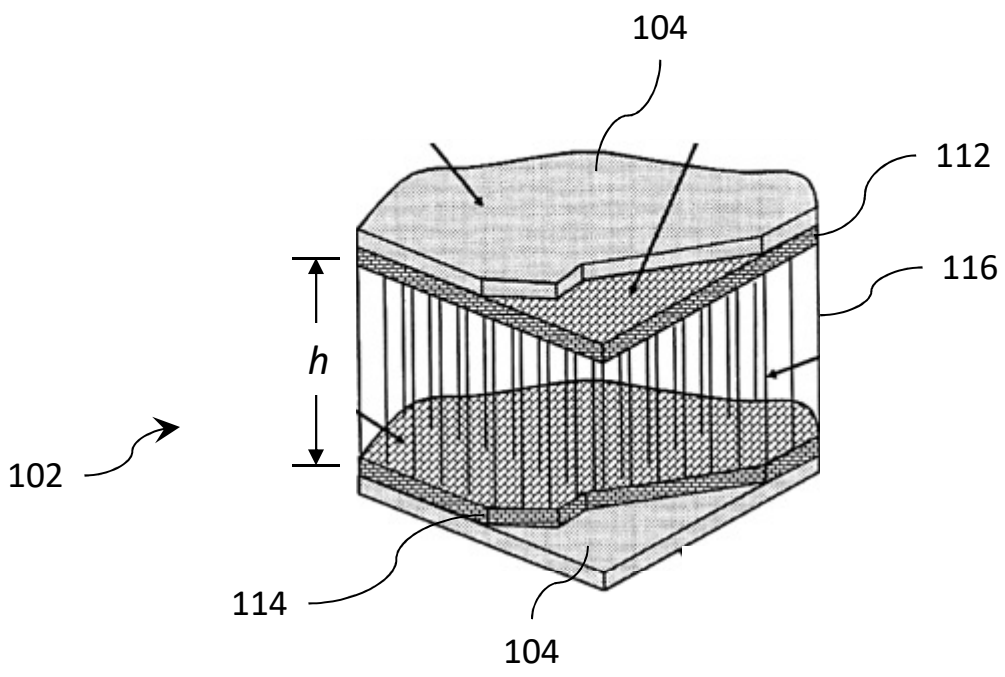

FIG. 3

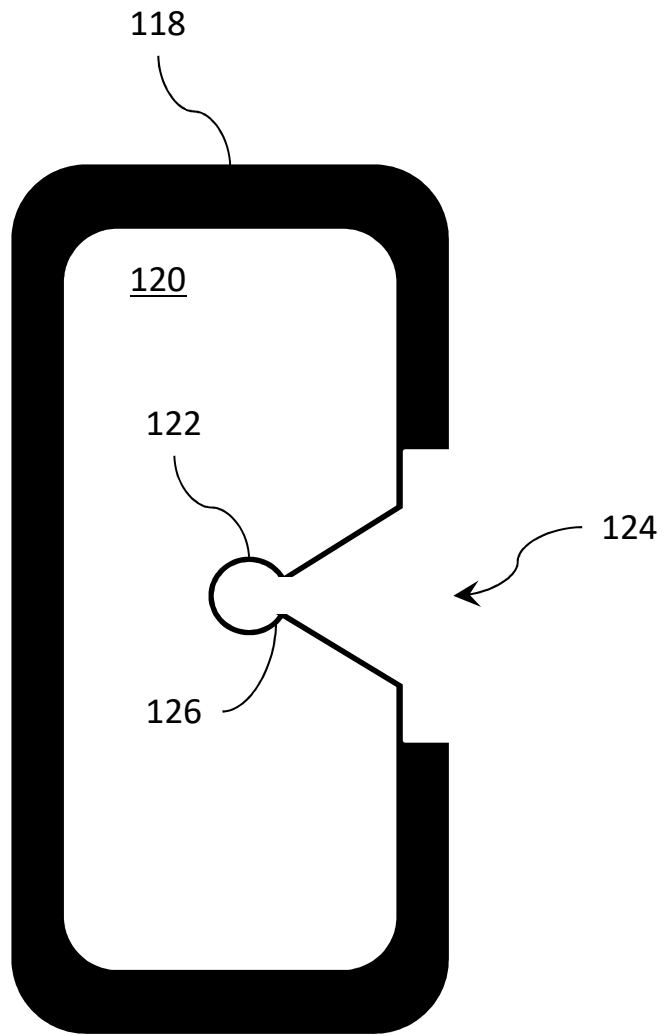

FIG. 4

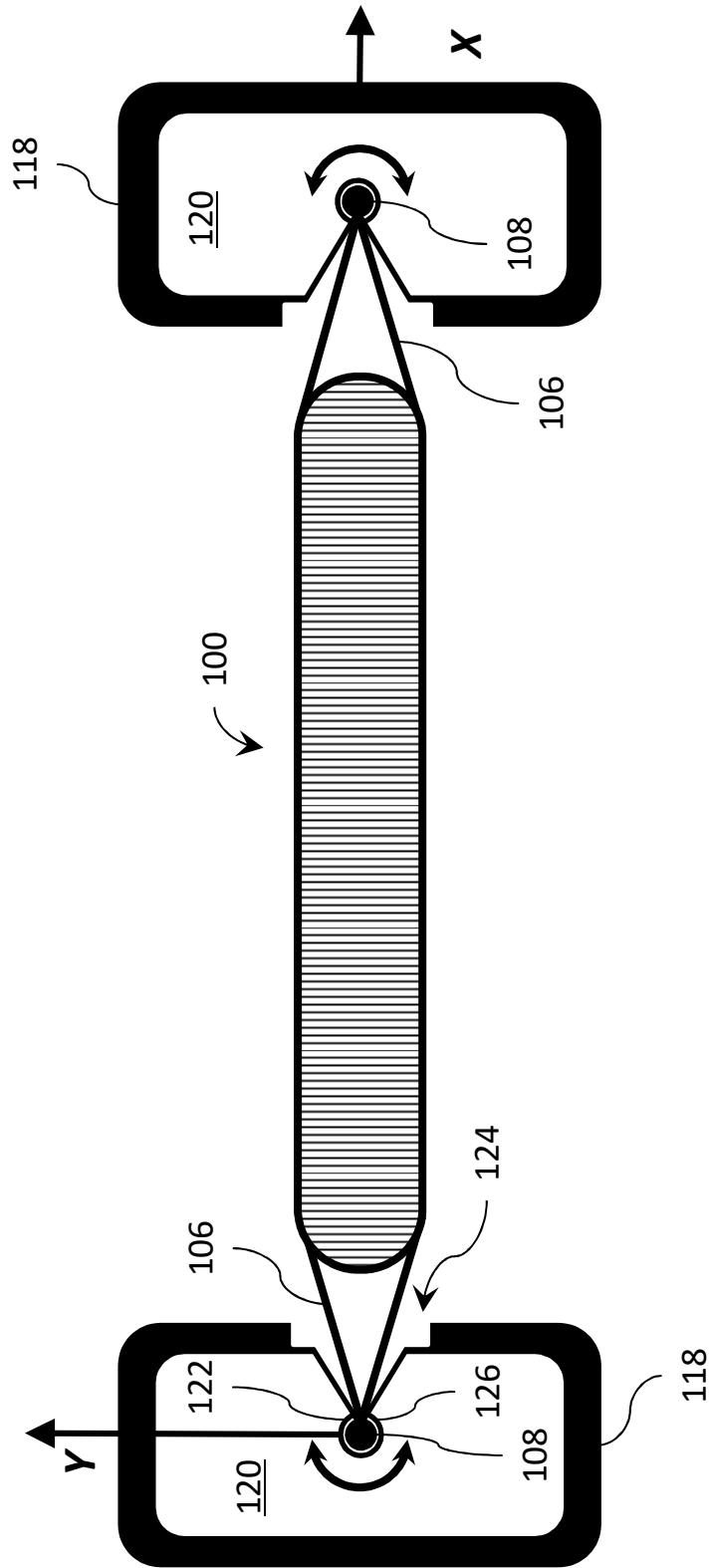

FIG. 5

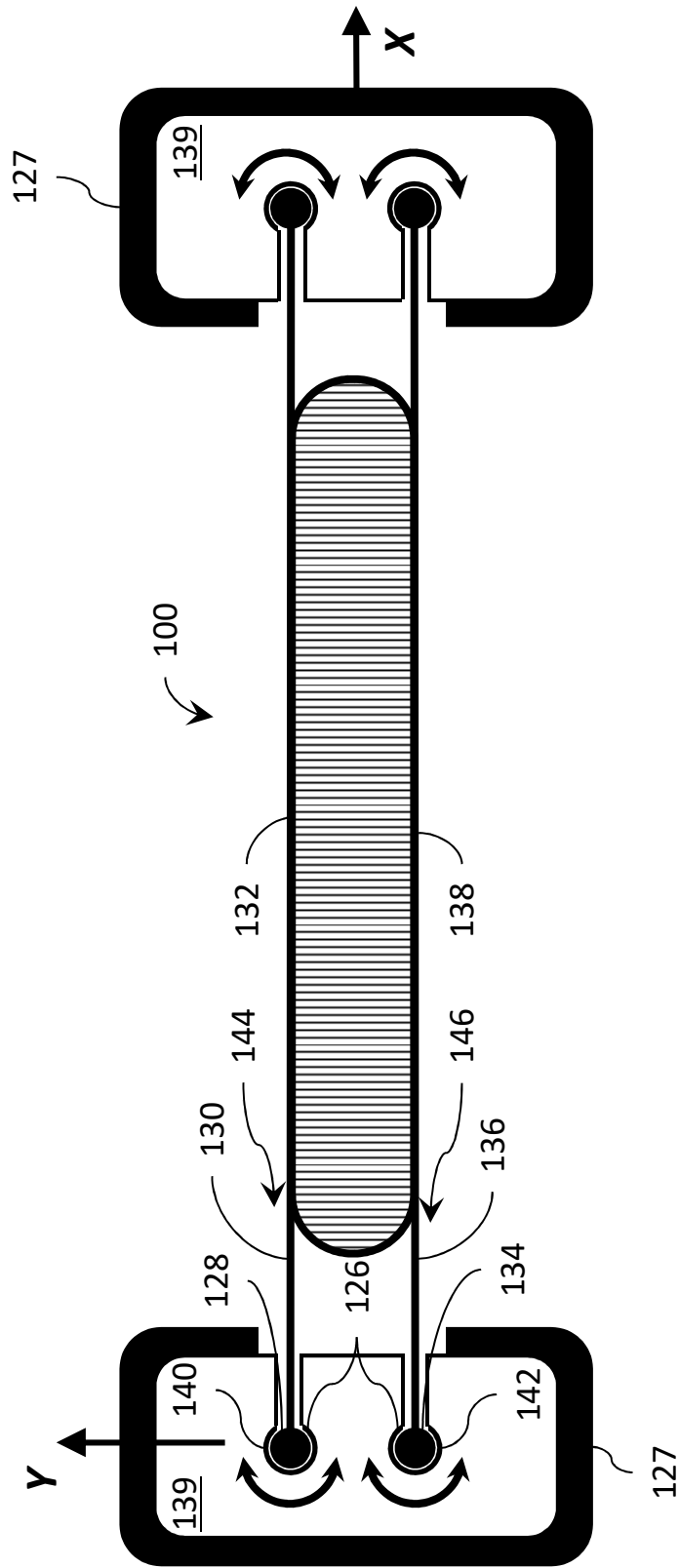

FIG. 6

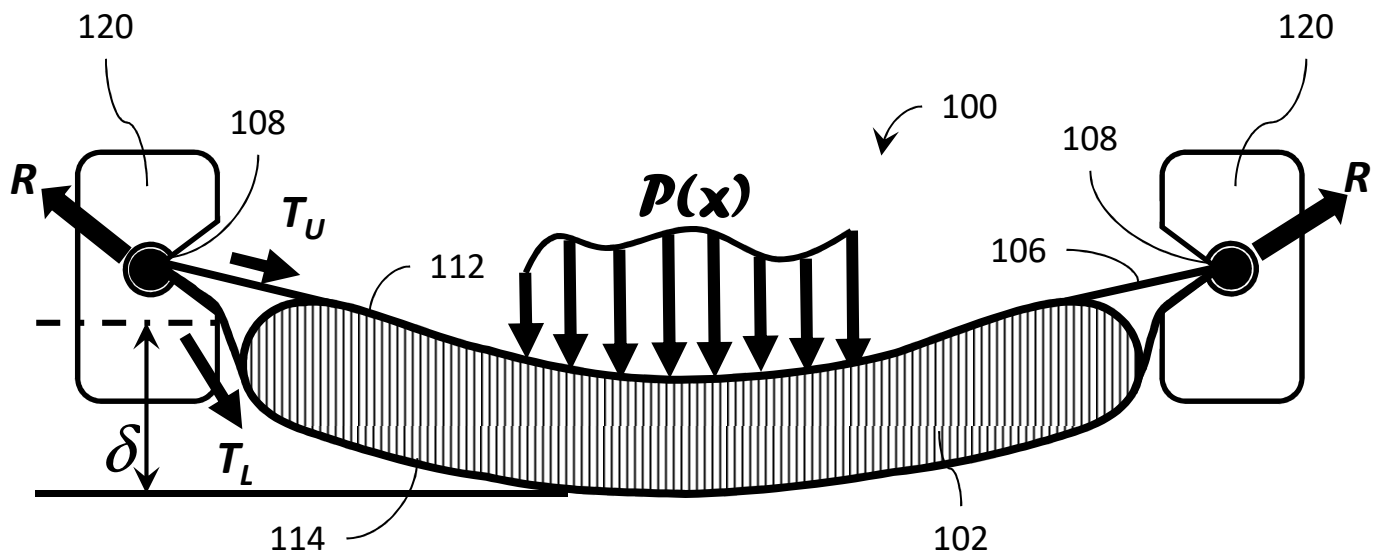

FIG. 7

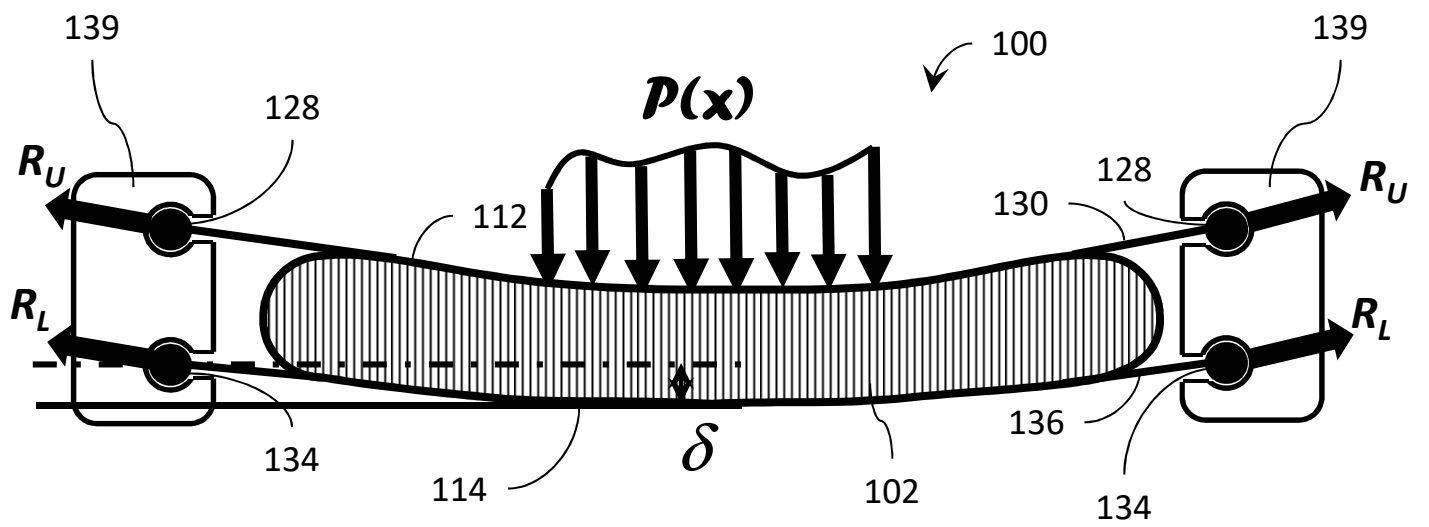

FIG. 8

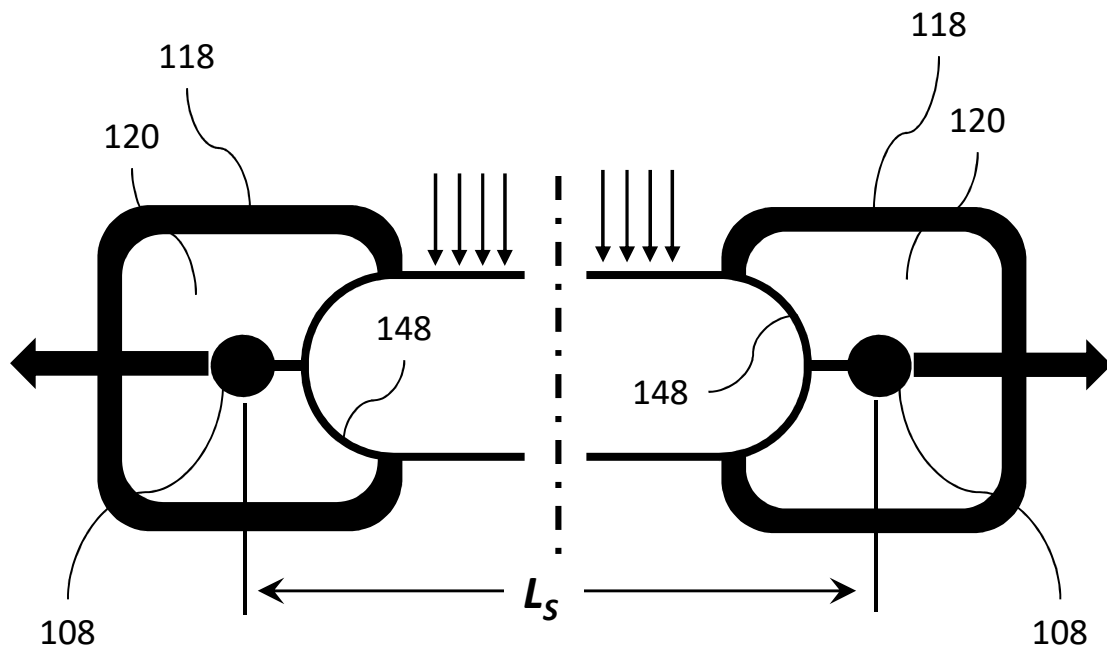

FIG. 9

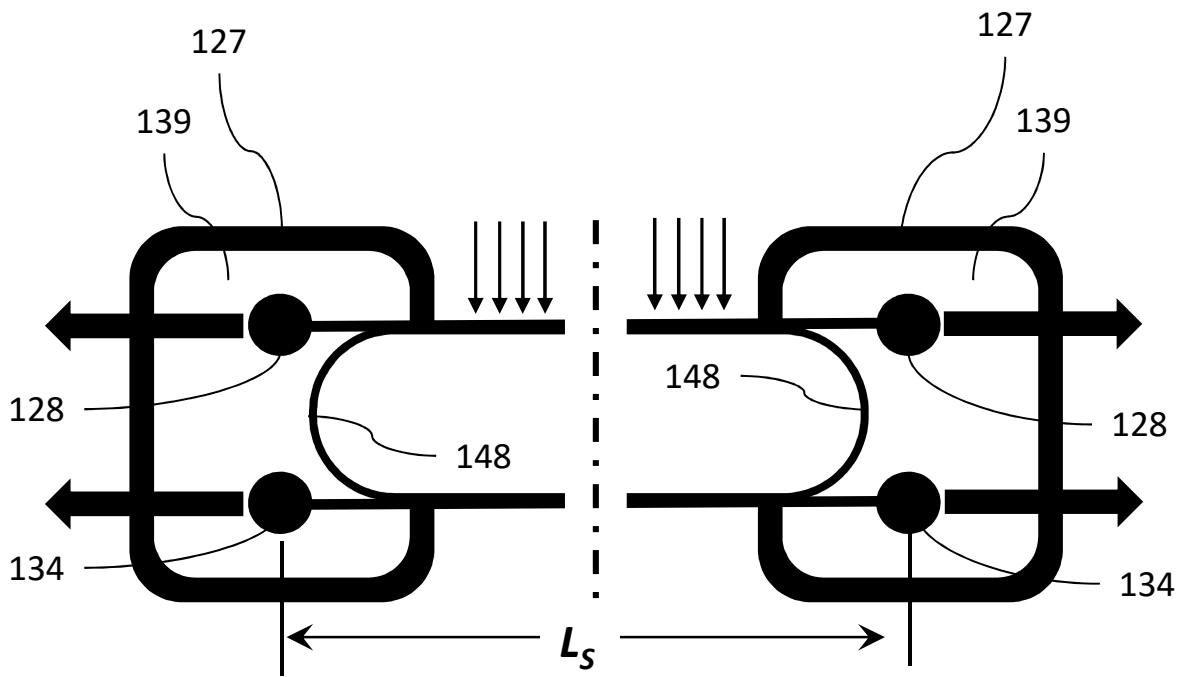

FIG. 10

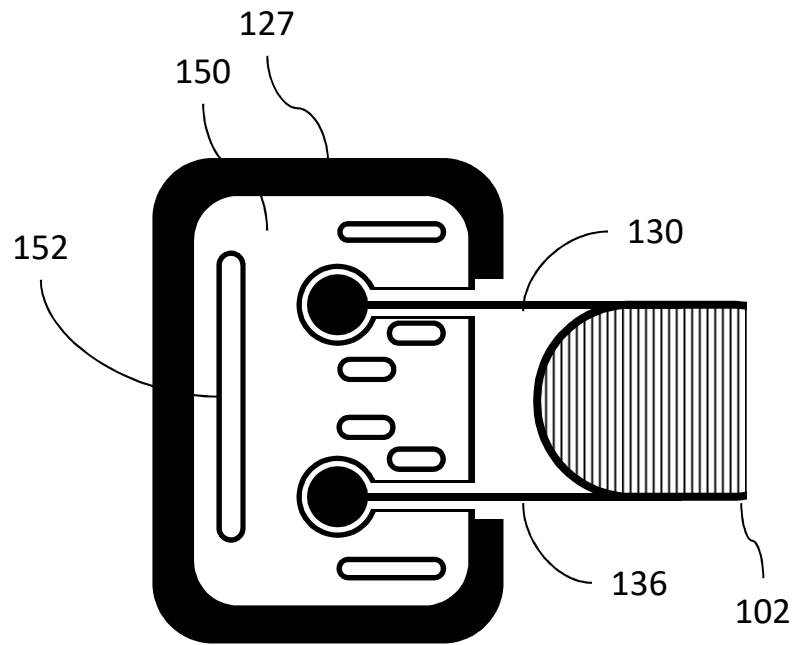

FIG. 11

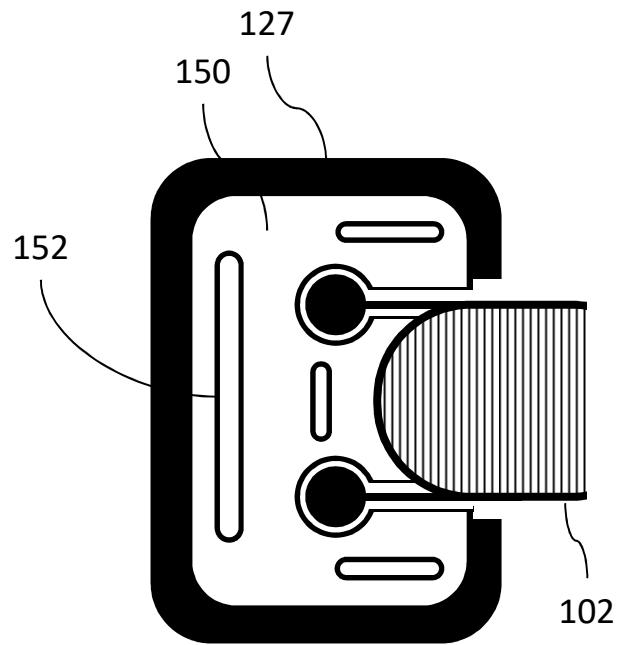

FIG. 12

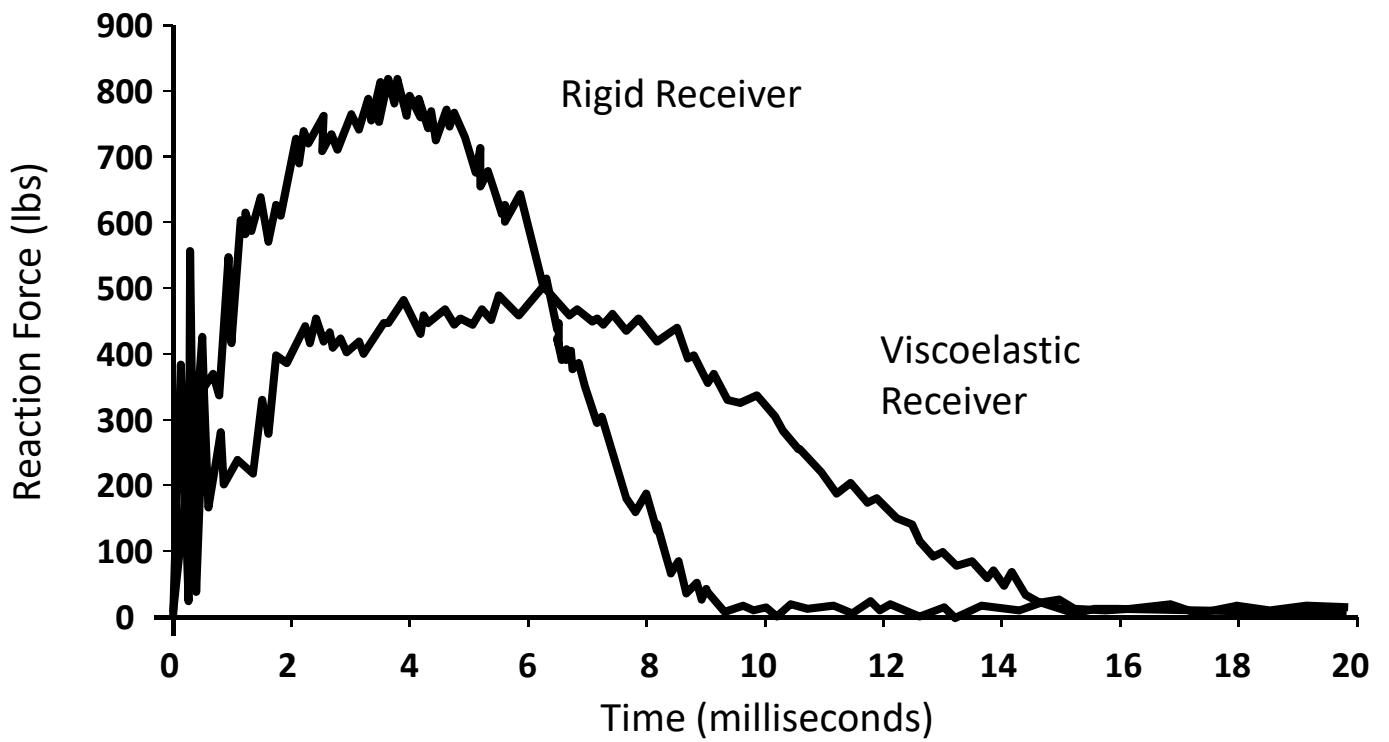

FIG. 13