



**US Army Corps
of Engineers®**
Engineer Research and
Development Center



Autonomous Transport Innovation (ATI)

Integration of Autonomous Electric Vehicles into a Tactical Microgrid

Angela Rolufs, Amelia Trout, Kevin Palmer, Clark Boriack,
Bryan Brillhart and Annette L. Stumpf

September 2021

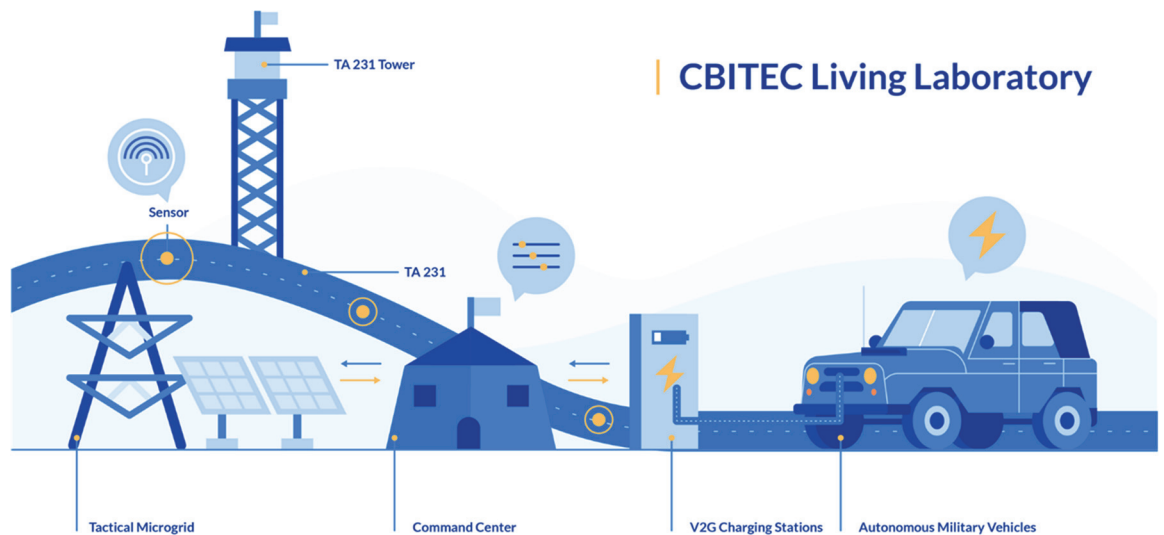

The U.S. Army Engineer Research and Development Center (ERDC) solves the nation's toughest engineering and environmental challenges. ERDC develops innovative solutions in civil and military engineering, geospatial sciences, water resources, and environmental sciences for the Army, the Department of Defense, civilian agencies, and our nation's public good. Find out more at www.erdclibrary.on.worldcat.org/discovery.

To search for other technical reports published by ERDC, visit the ERDC online library at www.erdclibrary.on.worldcat.org/discovery.

Autonomous Transport Innovation (ATI)

Integration of Autonomous Electric Vehicles into a Tactical Microgrid

Annette L. Stumpf

*U.S. Army Engineer Research and Development Center (ERDC)
Construction Engineering Research Laboratory (CERL)
2902 Newmark Dr.
Champaign, IL 61824*

Angela Rolufs and Amelia Trout

*Paragon Business Solutions, Inc.
610 N. Olive Street
Rolla, MO 65401*

Kevin Palmer

*CS2 (Center for Sustainable Solutions)
2700 Vinton Ct.
Charlottesville, VA 22901*

Clark Boriack

*TechFlow
9889 Willow Creek Road; Suite 100
San Diego, CA 92131*

Bryan Brillhart

*Robotic Research
555 Quince Orchard Road, Suite 300
Gaithersburg, MD 20878*

Final Technical Report (TR)

Approved for public release; distribution is unlimited.

Prepared for Headquarters, U.S. Army Corps of Engineers (HQUSACE)
Washington, DC 20314-1000

Under Project 6LKD1G “FY19 Program Increase: Autonomous Transport Innovation”;
and Contract Number W9132T19C0003, “Autonomous Transport Innovation:
Integration of Autonomous Electric Transport Vehicles into a Tactical Microgrid.”

Abstract

The objective of the Autonomous Transport Innovation (ATI) technical research program is to investigate current gaps and challenges then develop solutions to integrate emerging electric transport vehicles, vehicle autonomy, vehicle-to-grid (V2G) charging and microgrid technologies with military legacy equipment. The ATI research area objectives are to: identify unique military requirements for autonomous transportation technologies; identify currently available technologies that can be adopted for military applications and validate the suitability of these technologies to close need gaps; identify research and operational tests for autonomous transport vehicles; investigate requirements for testing and demonstrating of bidirectional vehicle charging within a tactical environment; develop requirements for a sensed, living laboratory that will be used to assess the performance of autonomous innovations; and integrate open standards to promote interoperability and broad-platform compatibility. The research performed resulted in an approach to develop a sensed, living laboratory with operational testing capability to assess the safety, utility, interoperability, and resiliency of autonomous electric transport and V2G technologies in a tactical microgrid. The living laboratory will support research and assessment of emerging technologies and determine the prospect for implementation in defense transport operations and contingency base energy resilience.

DISCLAIMER: The contents of this report are not to be used for advertising, publication, or promotional purposes. Citation of trade names does not constitute an official endorsement or approval of the use of such commercial products. All product names and trademarks cited are the property of their respective owners. The findings of this report are not to be construed as an official Department of the Army position unless so designated by other authorized documents.

DESTROY THIS REPORT WHEN NO LONGER NEEDED. DO NOT RETURN IT TO THE ORIGINATOR.

Contents

Abstract	ii
Figures and Tables	v
Preface	vi
1 Introduction	1
1.1 Background.....	1
1.2 Objectives.....	2
1.3 Technical Roadmap – Sensored Living Laboratory	2
2 Need and Value of Research	4
2.1 Policy Drivers.....	4
2.1.1 <i>Energy Independence and Security Act of 2007</i>	4
2.1.2 <i>Department of Defense operational energy strategy</i>	4
2.1.3 <i>U.S. Army’s Energy Security and Sustainability Policy</i>	5
2.1.4 <i>The CERL mission</i>	5
2.2 Electric transportation as a distributed energy resource	6
2.3 Military Vehicle Autonomy	6
2.4 Interoperability Between Devices	7
2.4.1 <i>Tactical microgrid standard</i>	8
3 Research Team	9
3.1 Paragon Business Solutions, Inc. – Prime Contractor.....	9
3.2 Robotic Research, LLC.....	10
3.3 TechFlow, Inc.....	10
3.4 The Center for Sustainable Solutions (CS2).....	10
3.5 Paul Brubaker, LLC	11
4 CBITEC Living Laboratory Roadmap – Sensored Living Laboratory to Assess Autonomous Transport Vehicles	12
4.1 Military requirements for autonomous transport and EV platforms that can support the identified requirements.....	12
4.2 EV platforms for military applications.....	14
4.3 Operational tests for autonomous transport vehicles and requirements for a Sensored Living laboratory to assess autonomous vehicle performance.....	18
4.3.1 <i>Example test plans</i>	21
4.3.2 <i>Recommended sensor suites</i>	25
5 CBITEC Living Laboratory Roadmap – Interoperable Living Laboratory to Assess V2G Charging in a Tactical Microgrid.	29
5.1 Catalog of CBITEC assets and identification of V2G evaluation capability requirements.....	29
5.1.1 <i>CBITEC system components</i>	29
5.1.2 <i>CBITEC V2G evaluation capability requirements</i>	30

5.1.3 V2G equipment information.....	31
5.2 Conceptual design of CBITEC Microgrid	32
5.3 Computer simulation platform – simulate V2G charging in the tactical Microgrid	33
5.3.1 Recommended V2G voltage and frequency ride-through.....	35
5.4 Test plan to evaluate V2G performance	36
5.5 Tactical microgrid model with Coritech V2G charger	40
5.6 Interoperability and standards gap analysis	41
6 CBITEC Living Laboratory Roadmap Summary.....	43
Bibliography.....	46
Report Documentation Page.....	47

Figures and Tables

Figures

1-1	Technical roadmap “sensored, living laboratory”	2
3-1	Paragon research team	9
4-1	CBITEC Living Laboratory roadmap	12
4-2	DANNAR Mobile Power System (MPS).....	16
4-3	New Flyer Xcelsior Charge Bus.....	17
4-4	Nikola Reckless	17
4-5	Orange Motors Yard Hauler	18
4-6	Operational Tests for Autonomous Transport Vehicles and Requirements for a Sensored Living Laboratory to Assess Autonomous Vehicle Performance	18
4-7	Test diagram	22
4-8	DGPS architecture	26
4-9	Node and distributed sensing setup	27
4-10	Sensor coverage maps	27
5-1	CBITEC Living Laboratory Roadmap	29
5-2	Coritech V2G charger	32
5-3	Tactical microgrid initial conceptual design	33
5-4	System model of the tactical microgrid	34
5-5	Site load/billet model.....	35
5-6	Test plan configuration.....	40
6-1	Roadmap for the sensor plan for CBITEC and TA231	43
6-2	Roadmap for the Coritech V2G charging station.....	43
6-3	Roadmap for the autonomous electric & tactical microgrid technologies.....	44
6-4	Roadmap for autonomous transport innovation.....	44

Tables

4-1	Prioritized military support activities	13
4-2	Baseline requirements to prioritize candidate technologies.....	14
4-3	Site requirements	20
5-1	System Components for Tactical Microgrid at CBITEC,.....	29
5-2	PV and V2G Ride-through % Base Setpoints	36
5-3	PV and V2G Ride-through Hz Setpoints	36
5-4	Generator Ride-through % Base Setpoints	36
5-5	Generator Ride-through Hz Setpoints.....	36
5-6	Test plan	37
5-7	Test plan conditions	39

Preface

This study was conducted for Headquarters, U.S. Army Corps of Engineers (HQUSACE) under Project 6LKD1G “FY19 Program Increase: Autonomous Transport Innovation,” Work Unit 6LKD1G, “Autonomous Transport Innovation”; and was executed under Contract Number W9132T19C0003 to Paragon Business Solutions, Inc. for the Broad Agency Announcement (BAA) proposal entitled “Autonomous Transport Innovation: Integration of Autonomous Electric Transport Vehicles into a Tactical Microgrid.”

The work was performed by the Engineering Processes Branch of the Facilities Division, U.S. Army Engineer Research and Development Center, Construction Engineering Research Laboratory (ERDC-CERL). At the time of publication, Mr. James Allen was Acting Chief of the Engineering Processes Branch; Ms. Giselle Rodriguez was Chief of the Facilities Division; and Mr. Kurt Kinnevan was the Technical Director for Installations. The Acting Deputy Director of ERDC-CERL was Ms. Michelle Hanson and the Director was Dr. Andrew Nelson.

Special thanks go to the entire ERDC-CERL project team for this effort. Ms. Susan J. Bevelheimer was Contracting Officer’s Technical Representative (COTR). Mr. Marcus Ferguson was Contingency Basing Integration Technology Evaluation Center (CBITEC) Site Integration Manager. Mr. Jonathan Goebel and Mr. Thomas Decker worked on CBITEC Electrification. Mr. Thomas Bozada worked on the Charging Station Development. Ms. Heather FitzHenry, Ms. Julie L. Webster, Mr. Matthew Gross, and Ms. Emma Smith worked on the Autonomy Innovation and Implementation Lab. Ms. Heather FitzHenry also served as co-project manager and was invaluable to envisioning the big picture for this project.

COL Teresa A. Schlosser was Commander of ERDC, and Dr. David W. Pittman was the Director.

1 Introduction

1.1 Background

This research project is the result of a successful proposal submitted by Paragon Business Solutions, Inc. (Paragon) to the Engineer Research and Development Center (ERDC) under the 2018 Broad Agency Announcement (BAA), Construction Engineering Research Laboratory (CERL): Innovative Energy Efficiency and Energy Security Initiatives (CERL-4) and Contingency Basecamp Operational Energy (CERL-6).

The project was developed in support of CERL's effort to accelerate the integration of autonomous vehicle technologies into defense transport operations. The goal of the project was to provide the Army with the capability to test and evaluate autonomous technologies in a realistic Army environment. This ability will allow the Army to test autonomous technologies, evaluate their performance, and identify issues, deficiencies, and safety risks before the autonomous technologies are implemented at a larger scale.

The research outcomes will contribute to the integration of autonomous vehicle technologies into defense transport operations with the development of operational testing capability for autonomous technologies at an ERDC asset on Fort Leonard Wood, the Contingency Basing Integration and Training Evaluation Center (CBITEC).

Through this year-long research effort, the Paragon team developed the roadmap for a novel sensed, living laboratory that can evaluate emerging electric transport vehicles, vehicle autonomy, vehicle to grid (V2G) charging, and microgrid technologies. The living laboratory will serve as a testbed to facilitate joint research and evaluation of autonomous electric vehicles (EVs) and bi-directional vehicle charging in a real-world, non-hostile environment. It will leverage government and industry technical expertise to accelerate technological advancement and innovation. The collaborative environment under which this research was conducted resulted in open innovation across technology borders that might otherwise be siloed. The living laboratory is, therefore, also a platform for collaborative innovation by leaders in these fields.

1.2 Objectives

The Autonomous Transport Innovation (ATI) project objectives were to:

- Identify military unique requirements for autonomous transport technologies
- Identify existing technologies that can be adapted for military applications, conduct technology gap analysis, and identify need gaps
- Identify research and operational tests for autonomous transport vehicles
- Investigate requirements for testing and demonstrating vehicle charging within tactical microgrid environment
- Develop requirements for a sensed living laboratory to assess performance of autonomous innovations
- Integrate open standards to promote interoperability.

1.3 Technical roadmap – Sensed Living Laboratory

This report describes the research program and provides a technical roadmap (Figure 1-1) to assist CERL in creating a sensed, living laboratory to demonstrate, monitor, and analyze performance of autonomous EVs and bi-directional charging in a tactical environment at the Fort Leonard Wood CBITEC.

Figure 1-1. Technical roadmap “sensed, living laboratory.”



The roadmap can be broken into two separate areas of research that can converge into the unique CBITEC Living Laboratory:

1. A sensed living laboratory to assess the performance of autonomous transport vehicles, including:
 - a. Recommendations for commercially-available EV platforms particularly well-suited for military missions that could be automated to the benefit of the government
 - b. Operational tests and sensor equipment that can be used to assess the effectiveness of autonomous vehicles under a variety of operating environments
 - c. A sensor plan for CBITEC and Training Area (TA) 231 that will provide capacity to assess autonomous vehicle performance data, as well as compare autonomous system performance to human driving behavior.
2. An interoperable living laboratory to assess V2G charging in a tactical microgrid including:
 - a. Conceptual design of a tactical microgrid at CBITEC that incorporates existing CBITEC assets
 - b. A software model of the conceptual design to simulate system performance with “what-if” scenarios
 - c. Individual software models with control logic to support control algorithm development
 - d. A test plan to evaluate V2G performance within a tactical microgrid
 - e. An analysis of gaps in interoperability standards and recommended solutions to bridge the standards gap at CBITEC.

2 Need and Value of Research

Policy drivers; rapidly emerging EV technologies, including the potential for EVs to provide a distributed energy resource; the Army's investment into autonomous vehicles; and the recognized need for interoperability between devices all demonstrate the need and value of the research conducted under this program. The development of a living laboratory to evaluate and demonstrate emerging autonomous EVs and distributed energy technologies will advance the military mission and foster innovation across government and industry sectors where no similar capabilities exist.

2.1 Policy drivers

2.1.1 Energy Independence and Security Act of 2007

The Energy Independence and Security Act of 2007 (EISA) codified “the policy of the U.S. to modernize the nation’s electricity transmission and distribution system to maintain a reliable and secure electricity infrastructure that can meet future demand growth and to achieve” prescribed characteristics of a modern grid.* Characteristics of a modern grid—through research, development, and demonstration of technologies—are actively deployed to advance the nation’s energy critical infrastructure and to fortify against cyber and physical attacks. The movement to a modernized grid, as outlined by the U.S. Department of Energy (DOE) Grid Modernization Initiative (GMI), is to develop a modern grid of the future that boasts “greater resilience, improved reliability, enhanced security, additional affordability, superior flexibility, and increased sustainability.”†

2.1.2 Department of Defense operational energy strategy

The U.S. Department of Defense (DoD) 2016 Operational Energy Strategy identifies three objectives to ensure consistent delivery of energy in support of the warfighter:

* 110th Congress. “TITLE XIII—SMART GRID.” Energy Independence and Security Act of 2007 [Public Law No: 110-140], 19 Dec. 2007, pp. 293–294., <https://www.congress.gov/110/plaws/publ140/PLAW-110publ140.pdf>.

† “Critical Infrastructure Sectors.” Cyber & Infrastructure Security Agency, U.S. Department of Homeland Security, 3 Mar. 2019, www.cisa.gov/critical-infrastructure-sectors.

1. Increase future warfighting capability by including energy throughout future force development
2. Identify and reduce logistics and operational risks from operational energy vulnerabilities
3. Enhance the mission effectiveness of the current force through updated equipment and improvements in training, exercises and operations.*

2.1.3 U.S. Army's Energy Security and Sustainability (ES2) Policy

Pursuant to the DoD Operational Energy Strategy, the U.S. Army's Energy Security and Sustainability (ES2) Policy defines a vision of "A ready and resilient Army, strengthened by secure access to the energy, water and land resources in order to preserve future choice in a rapidly changing world."[†] To achieve this vision, the ES2 Policy identifies five strategic goals in an effort to provide broad direction for the integration of improved energy and water use into the Army capabilities:

1. Inform decisions
2. Optimize use
3. Assure access
4. Build resiliency
5. Drive innovation.

Numerous Army initiatives and programs are underway that focus on supporting this vision. They include net-zero, large-scale renewable energy, and developing energy resilient power systems for forward operating bases.

2.1.4 The CERL mission

The CERL mission is to "develop and infuse innovative technologies to provide excellent facilities and realistic training lands for DoD, the U.S. Army and many other customers while also supporting ERDC's research and development mission in geospatial research and engineering, military engineering, and civil works."[‡]

* U.S. Department of Defense 2016 Operational Energy Strategy, February 2016

† U.S. Army Energy Security & Sustainability (ES2) Strategy, May 2015

‡ "Mission Statement." CERL Missions, U.S. Army Corps of Engineers Engineer Research & Development Center Construction Engineering Research Lab, www.erd.c.usace.army.mil/Locations/CERL/Missions.aspx.

2.2 Electric transportation as a distributed energy resource

The shift from fossil fuel-reliant transportation to electric transportation presents a new paradigm in the transportation and energy sectors. The onboard energy storage that electric transport vehicles provide introduces the potential to access an additional and distributed electric power supply through bi-directional power flow. V2G charging equipment, an emerging technology, is essential in enabling a bi-directional flow of electric power between electric transport and energy systems. It is this connection that allows electric transportation to provide ancillary energy and assurance to local energy generation, resulting in improved reliability, flexibility, and resilience.

2.3 Military vehicle autonomy

DoD has invested in technologies designed to reduce risks to the warfighter and decrease reliance on vulnerable resupply operations. Our research demonstrates that the integration of autonomous technologies with EVs transport is an important and developing technology worthy of future investment.

This commentary from the Army website demonstrates the future opportunities for autonomous vehicles and the potential advantages they can provide to the military mission:

The Department of Defense has been researching the use of autonomous vehicles since 2004, when the Defense Advanced Research Projects Agency (DARPA) funded specific research and technology and sponsored its first autonomous vehicle competition. While the most recent technical emphasis has undoubtedly been on front-line functions such as unmanned tactical vehicles or light maneuver capabilities such as bomb disarmament, those assets are not technically autonomous vehicles. Autonomous vehicles present opportunities to improve logistics, security, base operation and maintenance, transport and eventually warfighting. As such, they represent a significant advancement in how we conduct all phases of the military mission.*

* Henry, Capt. Matthew P. "Autonomous Transportation: Combat Power in the 21st Century." U.S. Army, 1 Nov. 2018, [army.mil/article/213078/autonomous_transportation_combat_power_in_the_21st_century](https://www.army.mil/article/213078/autonomous_transportation_combat_power_in_the_21st_century).

To achieve the Army’s vision for 2028, it has identified equipment modernization as a key objective with efforts focused on “... experimenting with and developing autonomous systems, artificial intelligence, and robotics to make our Soldiers more effective and our units less logistically dependent.”*

The number of applications and potential benefits for autonomous vehicles in forward operating areas include:

- Autonomous logistics operations could reduce the number of casualties associated with transport. According to the DoD, “Fifty-two percent of battlefield casualties occur when sustainers are delivering needed supplies to and from the battlefield.”†
- Supporting continuous (24 hours a day, 7 days a week) supply operations in theatre, efficiently creating and improving overall supply and resupply operations
- Support security for convoys and forward operating bases (FOBs) through increased reconnaissance capacity and, eventually, warfighting capability.

2.4 Interoperability between devices

Interoperability, as defined by the GridWise™ Architecture Council, is the

capability of two or more networks, systems, devices, applications, or components to work together, and to exchange and readily use information—securely, effectively, and with little or no inconvenience to the user. The modern grid will be a system of interoperable systems, which are different systems able to exchange meaningful, actionable information in support of the safe, secure, efficient, and reliable operations of electric systems. The systems will share a common meaning of the exchanged information, and this information will elicit agreed-upon types of response. The reliability, fidelity, and security of information exchanges between and among modernized systems must achieve requisite performance levels.‡

* General Mark Milley, Army Chief of Staff, Honorable Mark Esper, Secretary of the Army. “Army 2028 Mission and Vision Statement.” 26 March 2019, pp. 7.

† Henry, Capt. Matthew P. “Autonomous Transportation: Combat Power in the 21st Century.” U.S. Army, 1 Nov. 2018, army.mil/article/213078/autonomous_transportation_combat_power_in_the_21st_century.

‡ GridWise™ Architecture Council, “GridWise Architecture Council Interoperability Constitution Whitepaper,” October 2005 https://www.gridwiseac.org/pdfs/interoperability_path_whitepaper_v1_0.pdf

Federal and state agencies, utilities, stakeholders, and industry leaders are actively working to develop policies, protocols, and standards to promote system interoperability. California Public Utilities Commission (CPUC), California Energy Commission (CEC), California Air Resources Board (CARB), and California Independent System Operator (CAISO) make up a vehicle-grid integration working group to develop policies and align EV charging with the needs of the electric grid. The working group is tasked with assessing communication protocols necessary to enable EVs with capabilities to support bi-directional charging while economically participating in electricity markets at scale.*

2.5 Tactical microgrid standard

The Tactical Microgrid Standards Consortium (TMSC) is actively developing a standard to establish requirements for tactical microgrids (TM), including the interoperability and interfaces of the hardware and software relevant to tactical microgrid design as well as considerations of intelligent control, stability and performance, safety of personnel, security, and protection. The standard defines an open architecture to facilitate tactical microgrid source ability to communicate, provide, and use services and information between systems, regardless of manufacturer or version, without the need for operator intervention. Progress is slated “to establish open standards supporting a modular, highly cohesive system structure with full-design disclosure in order to leverage the collaborative innovation of industry, academia, and government participants and stakeholders.”† The tactical microgrid standard supports the development of advanced power systems that can bring energy resiliency to the warfighter through a tactical microgrid that:

- Consists of interoperable devices
- Uses a resilient, open architecture that is modular and scalable
- Accommodates mission-based equipment configurations
- Enables single-component upgrades and interactions instead of forcing system upgrades
- Utilizes multi-level cybersecurity.

* “DRIVE OIR Vehicle-Grid Integration Working Group.” Vehicle-Grid Integration Communications Protocol Working Group, California Public Utilities Commission, www.cpuc.ca.gov/vgi/.

† “Army takes key step in enabling interoperability of multinational power systems.” Dan Lafontaine, CCDC C5iSR Center Public Affairs, https://www.army.mil/article/223713/army_takes_key_step_in_enabling_interoperability_of_multinational_power_systems.

3 Research Team

Paragon’s unique research team (Figure 3-1) was key to the successful delivery of this multi-faceted project. Each team member brought recognized industry experience in one or more of the specific areas of research, while also bringing broad experience to support the entire team in the delivery of the program. The diagram below demonstrates the expertise and experience provided by each team member.

Figure 3-1. Paragon research team.



3.1 Paragon Business Solutions, Inc. – Prime Contractor

Paragon Business Solutions, Inc. provides project management, quality systems, and strategic energy expertise to improve the success and resilience of our customers. Paragon’s processes create a framework that is repeatable and proven to reduce risk, improve efficiency, and deliver desired results. Founded in 1997, Paragon is a U.S. Small Business Administration (SBA) Women-Owned Small Business (WOSB).

Angela Rolufs, Vice President for Strategic Energy Initiatives and the project proponent for the ATI Project, led the Paragon team by providing program management and overall project delivery.

3.2 Robotic Research, LLC

Robotic Research, LLC focuses on ground robotics, especially in localization, sensor processing, and intelligent command and control. Robotic Research has extensive experience with developing robotic systems for various vehicle types, ranging from the man-portable Talon to small electric shuttles and large Army Palletized Load System (PLS) trucks.

Bryan Brillhart, Senior Program Manager at Robotic Research, led the Research and Development (R&D) efforts for evaluating autonomous transport technologies in a tactical environment.

3.3 TechFlow, Inc.

Founded in 1995, TechFlow applies innovative engineering, technology, and integration solutions to the government's most demanding mission and business challenges. TechFlow's Energy and Mobility Solutions business unit employs subject matter experts with decades of proven performance in the areas of program management, engineering, energy effectiveness, V2G and microgrid applications/demonstrations, energy storage, technology transition, and resilience.

Clark Boriack, Director of Engineering for Energy and Mobility at TechFlow, led the research and demonstration efforts for the integration of V2G charging into a tactical microgrid.

3.4 The Center for Sustainable Solutions (CS2)

The Center for Sustainable Solutions (CS2) is a non-profit organization that works to advance sustainable practices throughout society by conducting education and outreach efforts on sustainable technologies, community systems development, long-term planning, and sustainable approaches to problem-solving within communities. CS2 works primarily with military installations and their surrounding communities to coordinate and promote sustainable technology demonstrations and validations.

Kevin Palmer, Founder and Director of CS2, leveraged his knowledge of military installations and emerging technologies to lead the identification of military transport operations that can be improved through automation. He engaged with military and civilian stakeholders to define requirements and identify need gaps.

3.5 Paul Brubaker, LLC

Paul Brubaker, Chief Executive Officer (CEO) and President of Paul Brubaker, LLC, supported the Paragon team by engaging Autonomous Vehicle (AV) subject matter experts (SMEs) to advise and provide input into the latest AV technologies that the team considered for tactical operations. He acted as a technical reviewer of the reports prepared by Paragon team members to ensure high standards are met as Paragon requires and ERDC-CERL expects.

4 CBITEC Living Laboratory Roadmap – Sensored Living Laboratory to Assess Autonomous Transport Vehicles

4.1 Military requirements for autonomous transport and EV platforms that can support the identified requirements



This section of the roadmap provides recommendations for commercially-available EV platforms that are well-suited for military missions and that could be automated to the benefit of the government. Figure 4-1 shows the CBITEC Living Laboratory roadmap.

Figure 4-1. CBITEC Living Laboratory roadmap.

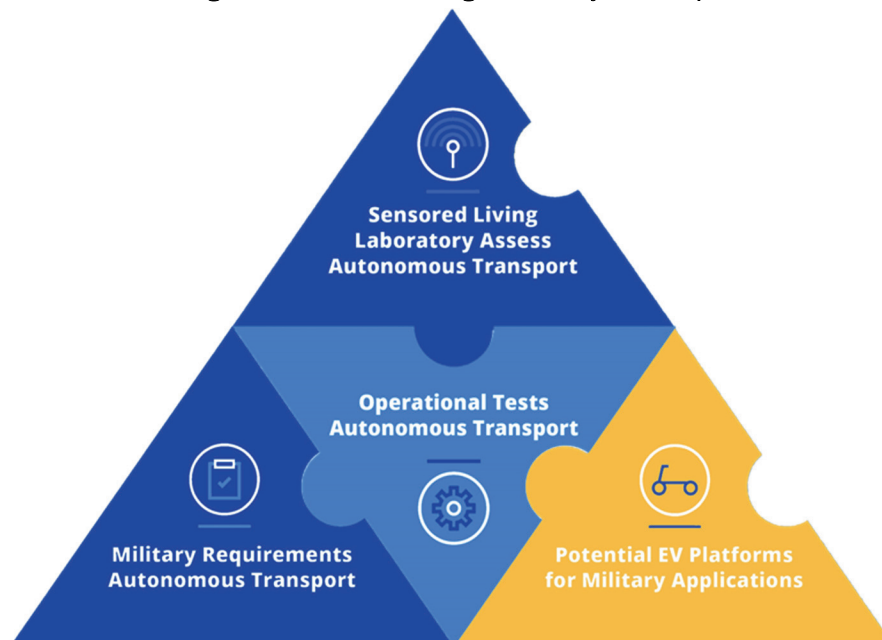

The Paragon team engaged with stakeholders and conducted research to identify transport-dependent military support activities (MSAs), the mission supported by the activity, and the type of vehicle used.

Table 4-1 lists the prioritized list of activities.

Table 4-1. Prioritized military support activities.

MSA #	MSA Type	Mission Supported	Vehicles
1	Personnel Transport: transport (1–4 people)	Installation Management Command (IMCOM)/Army Materiel Command (AMC) missions for logistics in support of installation operation – personnel transport supports all Continental United States (CONUS) housing, training and deployment functions. Mass transit is more common at basic training installations. Fort Leonard Wood provides 2.5 million round trips annually to move Soldiers to training areas, ranges, and dining facilities.	Automobile
	Personnel transport (5–20 people)		Shuttle
	Troop transport for training (platoon to company size—up to 250 Soldiers)		Buses (40–80) and tractor with personnel trailer (125)
2	Land Management: grounds maintenance—beautification and security cutting	IMCOM/AMC installation operation—grounds maintenance can include grass cutting, snow removal, dirt removal, wood clearing (with workers), tree removal (with workers), etc. Two types of ground maintenance are common: grass cutting in cantonment areas and less frequent grass cutting in range and training areas. This effort would be focused on large-scale mowers and earth movers that can be used to maintain CONUS range areas (and possibly cantonment areas).	Tractors and mowers
	Land Management: range maintenance		Large/farm tractors with cutting decks, plowing
3	Logistics: materiel transport—food, water, munitions, fuel, municipal solid waste	IMCOM/AMC Installation Operations directly supporting training (TRADOC), Garrison (FORSCOM) missions, and deployment (all installations that deploy personnel). Convoys used to support all forward operating areas.	Delivery trucks and vans, tractors with trailers, specialty trucks (tankers, refrigeration unit, waste hauler, bucket truck), secure trucks (munitions)
	Logistics: materiel management and warehousing—delivery, storage, and distribution		Forklifts, indoor and outdoor tugs, material handling equipment
	Logistics: airfield activities—US Army Ground System Vehicles (GSVs)		Various GSVs—fuelers, pallet loaders, aircraft tugs, small loaders, munitions movers and loaders (security), deicers, plows
3	Logistics: vehicle and equipment hauling	Vehicle and equipment recovery and delivery—supports IMCOM/AMC operations.	Tow trucks, vehicle lifts and haulers, tractors with trailers
4	Security monitoring	Reconnaissance in forward areas, as well as installation security monitoring.	Drones, reconnaissance vehicles
5	Land Preparation: earth moving, plowing, digging	IMCOM/AMC grounds maintenance, as well as combat engineering operations and training.	Engineering equipment—scraper, crane, dozer, plow, hauler, dump truck, grader, loader, backhoe, crawler, HYEX (Hydraulic Excavator)

MSA #	MSA Type	Mission Supported	Vehicles
6	Road Maintenance: maintenance, repair, snow removal	IMCOM/AMC installation maintenance and clearing, development, and maintenance of new and existing roads in forward areas.	Grader, sweeper, dump truck, asphalt paver, compactor, roller, snowplow

4.2 EV platforms for military applications

The research team evaluated candidate electric transport technologies for suitability against the prioritized military transport activities and for compatibility with future research requirements. Candidate technologies were prioritized by the number of criteria thresholds met. Screening criteria thresholds were Technology Readiness Level (TRL), target cost, location of assembly (within or outside the U.S.), battery capacity, complementary research, MSA requirements supported, and General Services Administration (GSA) availability. Screening criteria thresholds set baseline requirements to prioritize candidate technologies and enabled the development of the list provided below in Table 4-2.

Table 4-2. Baseline requirements to prioritize candidate technologies.

Priority	Total # of Y	TRL (7-9)	Cost ≤ \$450,000	Assembled in U.S.	Battery Capacity ≥50 kWh	MSAs Supported	Related Research	Available through GSA?
1	7	DANNAR Mobile Power System (MPS)						
		Y	Y	Y	Y	Y	Y	Y
		9	\$200-400K	IN	125-630 kWh	2, 4, 5, 6	DHS	GSA
2	6	Zenith Motors Cargo, Shuttle, & Step Van; Chassis & Cutaway Cab						
		Y	Y	Y	Y	Y	N	Y
		9	\$100K	CA	52-100 kWh	1, 3		GSA
3	6	Zero Truck Medium-duty Trucks, Shuttles and Buses						
		Y	Y	Y	Y	Y	N	N
		9	\$60-100K	CA	53-80 kWh	1, 3		
4	6	Phoenix Motorcars Zeus shuttle bus, utility vehicle, flatbed truck						
		Y	Y	Y	Y	Y	Y	N
		9	\$240,000+	CA	105 kWh	1, 3	EPA, CA	
5	5	Orange Motors T-Series Yard Hustler						
		Y	Y	Y	Y	Y	N	N
		9	\$200-300K	MO	80-160 kWh	1, 3		
6	5	Nikola Reckless						
		Y	N	Y	Y	Y	Y	N
		9	\$480K/year Lease	CA	52-100 kWh	4	USMC	
7	5	eBus electric shuttle						
		Y	Y	Y	Y	Y	N	N
		9	\$400K	CA	130 kWh	1		
8	5	New Flyer Xcelsior Charge Bus (multiple versions)						

Priority	Total # of Y	TRL (7-9)	Cost ≤ \$450,000	Assembled in U.S.	Battery Capacity ≥50 kWh	MSAs Supported	Related Research	Available through GSA?
		Y	N	Y	Y	Y	Y	N
		9	\$700-1,200K	AL	160-466 kWh	1, 3	Industry	
9	5	Rivian R1T Electric Pick-up						
		Y	Y	Y	Y	Y	N	N
		8	\$70-100K	Y	105-180 kWh	3, 4		
10	5	Thomas Built Saf-T-Liner C2 Jouley Electric School Bus						
		Y	Y	Y	Y	Y	N	N
		8	\$450K	NC	220 kWh	1		
11	5	ATC E-Drive Tractor						
		Y	Y	Y	Y	Y	N	N
		9	\$250K	MN	250 kW	2, 5, 6		
12	4	US Hybrid eCargo, eTruck drayage – Class 8 Tractor						
		N	Y	Y	Y	Y	N	N
		6	\$250K	CA	240 kWh	1, 3		
13	4	Nova Bus LFSe						
		Y	N	Y	Y	Y	N	N
		8	\$700K+	NY	152 kWh	1		

To validate the published vehicle information and determine the prospect for future research, Paragon team members contacted each priority technology manufacturer. Manufacturers who did not respond to repeated requests for engagement were removed from the list. Those who did agree to engage with the Paragon team were provided with a standard set of discussion topics as outlined below:

- Manufacturer and vehicle description
- V2G charging readiness and effort to implement
- Vehicle functions and capabilities
- Testing and demonstrations
- Autonomy readiness and effort to implement
- Safety assessments
- Pricing and warranties.

Based on the results of the engagement and collaborative team member evaluation, the following electric transport technologies are identified as holding great value for future military autonomy applications:

The DANNAR MPS is an off-road energy platform with unique versatility in application that could support a wide range of military activities with a

platform base that can be converted to a multitude of transportation systems (Figure 4-2).

- It meets the key operational and programmatic ATI testing and demonstration criteria to include autonomous and V2G capabilities with minimal implementation effort/cost
- The System has full remote capability, operating by onboard cab, x-box style remote control or wireless supervision.
- Currently working to develop follow-the-leader autonomous function.

Figure 4-2. DANNAR Mobile Power System (MPS).



The DANNAR system has maturity and commercial availability, pricing is in line with project parameters and the company is interested in participating in future research opportunities.

New Flyer manufactures the Xcelsior Charge electric bus and has experience in the electric transport system industry making manufactured zero-emissions buses for more than 50 years (Figure 5-3).

- Zero-emissions bus with a battery energy storage system ranging from 160 kWh to 460 kWh
- Does not have bi-directional charging capability
- Interoperable with all heavy-duty vehicle charging equipment.

Figure 4-3. New Flyer Xcelsior Charge Bus.



New Flyer has partnered with Robotic Research, LLC to develop a proof-of-concept autonomous bus. New Flyer has committed to additional autonomous bus programs with the Xcelsior Charge.

The Nikola Reckless is a fully electric side-by-side utility vehicle that offers flexibility with the design of its open chassis (Figure 4-4).

- Offers off-road performance, estimated to have a range of more than 150 miles and top speed of 75 mph
- Available with powertrains ranging from 266–590hp and is powered by a 400VDC battery system with 75–125kWh of energy storage
- Interoperable with a Remote Weapon Station and military drones
- Has steer and throttle by wire capabilities, and Nikola is working to develop more autonomous capabilities
- The vehicle's onboard energy storage is large for the size of the vehicle and would be beneficial for bi-directional charging; the company has expressed interest in working toward this capability.

Figure 4-4. Nikola Reckless.



Orange Motors builds, sells and services industrial EVs and is the leading original equipment manufacturer (OEM) providing industrial fleets with heavy duty electric trucks (Figure 4-5).

- Electric hauler that could serve low-speed purposes at an installation
- Purpose-built to site requirements and have heavy hauling capacity (81,000 lbs.)
- DoD certified for on- and off-road use, maximum speed is currently 25 mph
- Utilizes a web-based telematics system that provides instant feedback, real time performance statistics, and hard data, enabling fleets to understand system status, fuel efficiency, and cost savings
- Located in Riverside, Missouri.

Figure 4-5. Orange Motors Yard Hauler.



4.3 Operational tests for autonomous transport vehicles and requirements for a sensed living laboratory to assess autonomous vehicle performance

This section of the roadmap identifies operational tests that can be used to assess the effectiveness of autonomous vehicles under a variety of operating environments. These recommendations ensure that the living laboratory will have the capacity to assess relevant vehicle performance data as well as compare autonomous system performance to human driving behavior (Figure 4-6).

Figure 4-6. Operational tests for sensed living laboratory to assess autonomous vehicle performance.

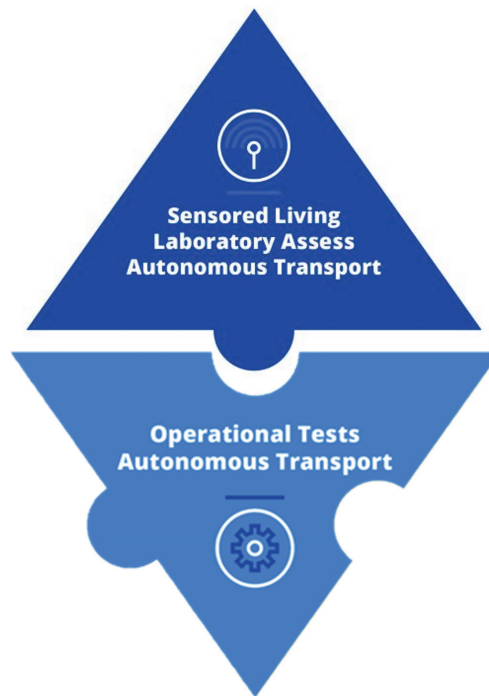

The Paragon research team, led by Robotic Research, researched and identified appropriate sensors and methods to measure performance of autonomous systems within the CBITEC site. The team provided high-level test plans that defined the scope, objective, key personnel, and approach for the following tests: traffic interaction, sensor degradation, terrain identification, and charging station docking.

Robotic Research's team of engineers are subject matter experts in autonomous software and hardware development and integration. The following list of requirements developed by the Robotic Research engineering team define the high-level infrastructure, sensors, and data necessary to measure autonomous system performance within the living laboratory at CBITEC. These requirements (Table 4-3) are meant to evolve, or be further derived, as more details about the test site are defined.

Table 4-3. Site requirements.

Operation	Site Requirement
Infrastructure	<ul style="list-style-type: none"> Requirement 1: The living laboratory will have provisions to charge an EV. Requirement 2: The living laboratory will have electrical power connections for sensors. Requirement 3: The living laboratory shall have semi-permanent mounting points for sensors. (Semi-permanent mounts can be removed from the site without causing damage or disturbing the site). Requirement 4: The living laboratory will have wireless communication capabilities.
Sensors	<ul style="list-style-type: none"> Requirement 5: The living laboratory will be able to detect autonomous systems at the site. Requirement 6: The living laboratory will be able to measure the relative position of autonomous systems at the site. Requirement 7: The living laboratory will be able to measure absolute position of autonomous systems within 0.1 meters. Requirement 8: The living laboratory will be able to communicate absolute position of the autonomous systems at the site. Requirement 9: The living laboratory autonomous detection system will be able to operate in varying lighting conditions, such as full daylight, dusk, and night.
Data Collection	<ul style="list-style-type: none"> Requirement 10: The living laboratory will be able to collect and store time data. Requirement 11: The living laboratory will be able to collect and store weather data. Requirement 12: The living laboratory will be able to collect and store autonomous system position data. Requirement 13: The living laboratory will be able to collect and store autonomous system attitude data. Requirement 14: The living laboratory will be able to collect and store autonomous system velocity data. Requirement 15: The living laboratory will be able to collect and store autonomous system sensor health data.

Paragon's team researched autonomous system data, state-of-the-art capture and storage technologies, and recommended solutions to facilitate autonomous technology operation and performance testing. The nSight suite, developed by Robotic Research, was recommended as an end-to-end data collection and analysis solution. The nSight captures multiple streams of data with a single data-logging device, which timestamps and performs post processing operations and analytics all in one location. The nSight suite is composed of the nSight Recorder (onboard data recorder), nSight Upload (data disseminator to servers), nSight AAR (server and analysis tool).

Paragon's research team developed test plans to verify autonomous system safety, operation, and performance. The operational test plans are designed to assess baseline system performance, traffic safety and interaction, sensor degradation, terrain identification, and V2G station docking. These test plans are applicable to the FLW test areas, specifically CBITEC and the TA-231 Driving Course. The test plans are also scalable and can be tailored to suit technology and test cases as needed.

4.3.1 Example test plans

4.3.1.1 Traffic interaction test plan

The purpose of this test plan is to describe operational tests that can be used to quantify an AV's performance in an on-road environment when interacting with pedestrians and other vehicles. It is expected that the autonomous systems will be bound to a single lane of travel and not allowed to drive in the oncoming traffic lane or on the shoulder.

The following data should be collected during this test:

- Time of test (local and global position system (GPS))
- Location of test
- Autonomous system under test
- Autonomous system telemetry data (position, attitude, velocity, acceleration)
- Autonomous system vision sensor data (Lidar, radar, camera)
- Environmental and ambient conditions (temperature, humidity, pressure, light)
- Living laboratory sensor data (GPS, Lidar, radar, camera).

Entrance criteria consist of:

- Required test personnel are present
- Autonomous system has been baselined
- Autonomous system sensors have been verified functional
- Differential Global Positioning System (DGPS) base station and non-vehicle-mounted sensor data collection system verified functional
- Maximum speed for autonomous under-test system defined
- Temporary infrastructure (stop signs, lane markers, crosswalks) have been placed, and locations have been recorded.

The following tests should be conducted on the road surface of the TA-231 Driving Course (Figure 4-7):

- Place a child-sized mannequin beyond the maximum range of the Lidar. Drive the AV toward the mannequin at 5 mph. Process the data to determine the range of the first detection.

- Park a car beyond the maximum range of the Lidar. Drive the AV toward the car at 5 mph. Process the data to determine the range of the first detection.
- Position a child-sized mannequin beyond the maximum detection range of the Lidar. Autonomously drive the vehicle toward the mannequin until the vehicle autonomously stops. Measure the distance between the vehicle and mannequin with a tape measure.
- Drive a compact car at 10 mph across the route of the autonomous system. Autonomously drive the autonomous system toward the compact car until the autonomous system stops. Measure the distance between the autonomous system and compact car with a tape measure. Conduct multiple trials increasing the compact car starting location by 10 meters until the maximum range of Lidar is achieved.

Figure 4-7. Test diagram.

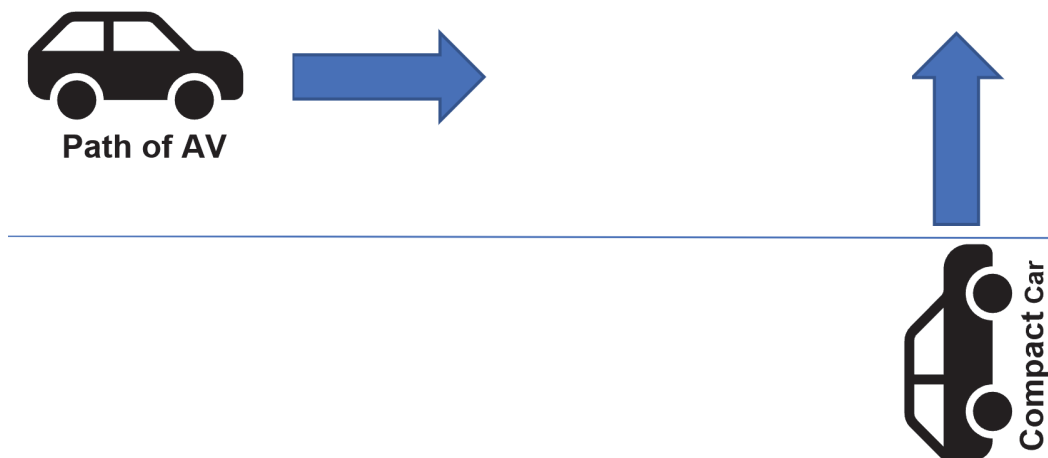

Exit criteria consist of:

- Route completed either autonomously or with safety operator's intervention
- Test data collected
- Living laboratory sensor data collected.

4.3.1.2 Terrain identification test plan

The purpose of this test plan is to describe operational tests that can be used to measure an autonomous system's ability to identify terrain.

The following data should be collected during this test:

- Time of test (local and GPS)
- Location of test
- Autonomous system under test
- Autonomous system telemetry data (position, attitude, velocity, acceleration)
- Autonomous system vision sensor data (Lidar, radar, camera)
- Environmental and ambient conditions (temperature, humidity, pressure, light)
- Living laboratory sensor data (GPS, Lidar, radar, camera).

Entrance criteria consist of:

- Required test personnel are present
- Autonomous system has been baselined
- Autonomous system sensors have been verified functional
- TA-231 Driving Course has been mapped by the autonomous system
- DGPS base station and non-vehicle-mounted sensor data collection system verified functional
- Maximum speed for autonomous under test system defined.

The following tests should be conducted at TA-231 Driving Course:

- Start with the autonomous system on the test loop of the driving course where the foliage is high on either side of the course.
- Command the system to navigate to a point on the other side of the course. The direct line path between the autonomous system and the end point should go through foliage and overgrowth.
- Verify that the autonomous system plans a route that stays on the driving course surface as it navigates to the commanded endpoint.
- Return the autonomous system to the starting point above. Place barricades, or barrels, in front of the vehicle to block the path it took above.
- Command the system to navigate to a point on the other side of the course and verify that the system plans a route that goes the opposite direction around the course.

Exit criteria consist of:

- Route completed either autonomously or with intervention

- Test data collected.

4.3.1.3 Charging station docking test plan

The purpose of this test plan is to describe operational tests that can be used to measure an autonomous system's ability to dock with a charging station.

The following data should be collected during this test:

- Time of test (local and GPS)
- Location of test
- Autonomous system under test
- Autonomous system telemetry data (position, attitude, velocity, acceleration)
- Autonomous system vision sensor data (Lidar, radar, camera)
- Environmental and ambient conditions (temperature, humidity, pressure, light)
- Living laboratory sensor data (GPS, Lidar, radar, camera).

Entrance criteria consist of:

- Required test personnel are present
- Autonomous system has been baselined
- Autonomous system sensors have been verified functional
- Charging station functional
- DGPS base station and non-vehicle-mounted sensor data collection system verified functional
- Maximum speed for autonomous under test system defined.

The following tests should be conducted at CBITEC:

- Start with the autonomous system on the entrance to the autonomous test site, and command autonomous system to navigate to charging station.
- Verify that the autonomous system is able to navigate to the charging station test pad and measure the position and attitude of the AV relative to the docking station.
- Verify and record if the autonomous system was able to connect to the charging station.

Exit criteria consist of:

- Route completed either autonomously or with intervention
- Test data collected.

To operationalize the test plans, the research team recommends outfitting test areas with sensor suites as detailed below.

4.3.2 Recommended sensor suites

In order to characterize the performance of an autonomous system, the absolute and relative position of the system must be accurately and repeatedly measured. There are a variety of ways to measure the position of the systems. Some include sensors mounted on the autonomous system, and some include sensors mounted at the test site.

The Robotic Research team of engineers are SMEs in sensor testing and integration. The following sections will describe the different types of sensors and their benefits. Additionally, data collected from a variety of sensors tested by Robotic Research will be presented.

4.3.2.1 Vehicle-mounted measurement sensors – differential global positioning system DGPS enhances traditional GPS solutions by supplying position corrections from a fixed location. DGPS uses two GPS receivers and a communication mechanism between the two.

One is at a fixed location where the exact position is known, either by survey or by measuring the GPS position for long periods of time (24–48 hours). The other receiver is mounted on the autonomous system. The fixed-location receiver, called a base station, computes the real time GPS solution and compares that to its known location. The comparison is used to compute a correction factor between the real time GPS solution and the known location. The correction factor is then sent to the GPS receiver on the autonomous system and applied to the GPS solution of the autonomous system. DGPS can improve the position solution of the autonomous system from over 1 meter of accuracy to less than 0.1 meter of accuracy (Figure 4-8).

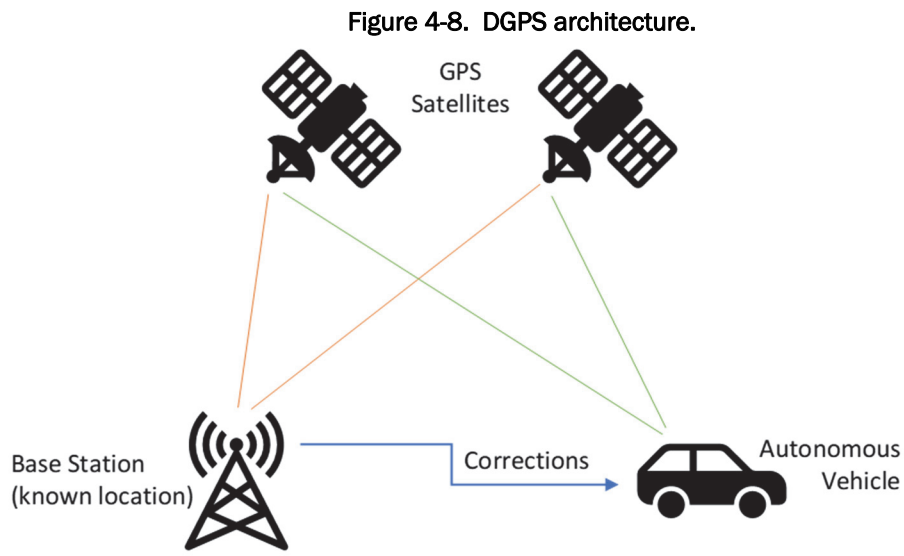

4.3.2.2 Site-mounted vehicle sensors

In addition to vehicle-mounted measurement sensors, another option to track and measure autonomous system performance is with sensors mounted at fixed positions within the test site. In this scenario, vision-based sensors (Lidar, radar and cameras) would be mounted at locations that provide optimal viewing of the test area, and the data from each sensor would be collected in a central repository via a physical connection.

Just as the Lidars, radars, and cameras mounted on autonomous systems classify and track different objects that interact with the vehicle, the fixed-location sensors can classify and track the different autonomous systems operating within the test site. This type of system would be more beneficial when testing in areas with poor GPS coverage or when testing indoors. The Safe Autonomous Unmanned Vehicles for Installations (SAUVI) surveillance tool suite was originally developed to allow autonomous systems to have greater situational awareness by providing data to the system from sensors that were mounted along the autonomous system's route. The SAUVI system is composed of the sensor node and distributed sensors. An example of the node and distributed sensing setup is shown below in Figure 4-9:

Figure 4-9. Node and distributed sensing setup.

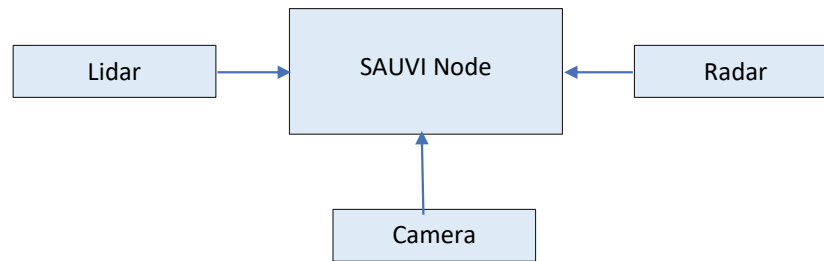

A hybrid approach of DGPS and visual sensors would provide the best results for outfitting the CBITEC and TA 231 site, as demonstrated in the below sensor coverage maps (Figure 4-10):

Figure 4-10. Sensor coverage maps.



Test areas with larger road networks become economically infeasible to outfit with vision-type sensors. The number of sensors required to cover the area and the additional infrastructure needed to power the sensors makes using a differential base station a more cost-effective option. In smaller test areas, such as CBITEC, both vision-type sensors and DGPS could accurately measure the autonomous system's position and attitude. Additionally, a hybrid approach could be used with both DGPS and a single set of vision-type sensors. The hybrid approach would allow for the vision sensors to cover areas that might have degraded GPS.

CBITEC and TA 231 provide unique capabilities to test autonomous system behaviors:

- Simulated FOB environment

- Availability of both on and off-road driving areas
- A variety of weather conditions provided by Fort Leonard Wood's climate
- Tactical microgrid interface
- Proximity of two sites would allow for shared use of sensors between the sites.

5 CBITEC Living Laboratory Roadmap – Interoperable Living Laboratory to Assess V2G Charging in a Tactical Microgrid

5.1 Catalog of CBITEC assets and identification of V2G evaluation capability requirements

This area of the roadmap (Figure 5-1) provides a catalog of CBITEC tactical microgrid assets and identifies what would be required to add V2G evaluation capability to microgrid.

Figure 5-1. CBITEC Living Laboratory Roadmap.

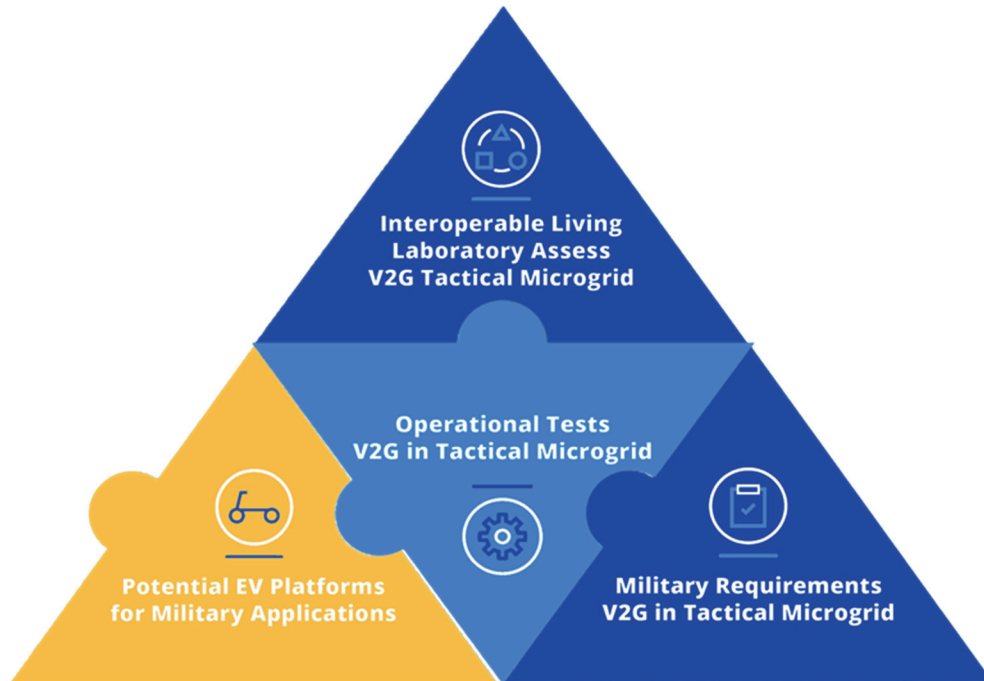

5.1.1 CBITEC system components (Table 5-1)

Table 5-1. System Components for Tactical Microgrid at CBITEC.

No.	Component Description	Operational Status	Notes
1	PDISE distribution center (100A)	Available	PDISE power distribution box
2	PDISE distribution center (200A)	Available	PDISE power distribution box
3	M100 distribution cables (100A)	Available	PDISE power distribution cables
4	M200 distribution cables (100A)	Available	PDISE power distribution cables
5	Site electrical loads	Available	ECUs, lighting, laundry on site
6	Test loads	Available	60-kW (minimum) three-phase resistive and reactive load banks to be provided as needed

No.	Component Description	Operational Status	Notes
7	Advanced Medium Mobile Power Sources (AMMPS) generation (60 W)	Available	Cummins generator
8	Lithium ion energy storage system (ESS) (40 kWh)	Not operational	Might be removed
9	Flow battery energy storage (300 kWh)	Not operational	Might be removed
10	Lead acid energy storage	Not operational	Will be removed
11	PhotoVoltaic (PV) array (100 kW)	Not operational	(4) 25-kW inverters need to be upgraded
12	IPD box (200A)	Available	Test units made by HG Engineers
13	IPD box (800A)	Available	Test units made by HG Engineers
14	Metering stations	Available	Existing deployable metering and monitoring system (DMMS)
15	Microgrid controller	In development	Being developed by C5ISR
16	Dashboard	Multiple	Investigating each for applicability/capability for a living laboratory

5.1.2 CBITEC V2G evaluation capability requirements

To add evaluation capability to the CBITEC microgrid, the following approach would be used:

- Develop performance requirements for the Equipment Under Test (EUT)
- Implement a sensor and metering system to measure performance
- Provide a test plan that will validate the equipment can meet performance requirements
- Conduct applicable test use cases.

A high-level roadmap to implement V2G operations in the tactical microgrid consists of:

- Hardware installation
 - Install V2G charger, step-down transformer, reference generators, loads, integrated power device (IPD), and interconnecting cables to form microgrid
 - Commission installed equipment
- V2G charger configuration
 - Configure voltage and frequency settings to avoid nuisance trips
- Establish charger communications
 - Install and configure wireless access points for data collection
 - Install wired communications per microgrid communications design
 - Update dashboard for data collection

- IPD configuration
 - Configure protective per connected equipment ratings and planned operation
 - Configure communications for data collection
- Microgrid controller development
 - Identify desired control capabilities
 - Develop control scheme and algorithms
 - Develop communications strategy to meet monitoring and control requirements
 - Install and commission microgrid controller
- System commissioning
 - Verify communications
 - Verify safety mechanisms and e-stops
 - Develop and conduct test plans to test equipment operation and control
 - Develop and conduct test plans to test system operation and control.

5.1.3 V2G equipment information

Chargers that are rated near 50 kW are referred to as “fast chargers” and are specifically designed to quickly charge an EV. To quickly charge an EV, fast chargers use direct current (DC) to charge the vehicle’s battery. By permanently installing power conversion equipment off-board of the EV, DC charging reduces both the weight and space burdens power conversation equipment place on an EV. DC fast chargers are designed to operate at much greater power levels—typically 30–100 kW compared to 1.4–19 kW for alternating current (AC) “standard” charging. In the U.S. there are three fast charging-standards that specify the communications and control between an EV and a fast charger:

- Tesla
- The Combined Charging System (CCS)
- CHAdeMO.

Tesla fast chargers utilize closed and proprietary protocols and only work with Tesla EVs; they do not provide V2G capability. The only supplier providing Commercial Off the Shelf (COTS) V2G chargers in the United States is Coritech Services, Inc. Coritech offers V2G with the option of either a Society of Automotive Engineers (SAE) CCS or CHAdeMO communication standard. Until SAE updates the CCS standard to include V2G

operations, a V2G charger ordered to operate according to the SAE CCS standard requires additional engineering services to develop and implement additional communications messaging for the selected vehicle. Therefore, a Coritech V2G charger with the CHAdeMO communication standard is the selected V2G equipment for this research effort (Figure 5-2).

Figure 5-2. Coritech V2G charger.



5.2 Conceptual design of CBITEC microgrid

A conceptual design of the CBITEC microgrid provides a representative model from which a plan to simulate performance can be developed. The conceptual design consists of six 60-kW AMMPS generators, three 50-kW V2G systems, and three critical loads connected in a bus formation using IPD-style distribution boxes. The tactical microgrid initial conceptual design is shown below in Figure 5-3:

Figure 5-3. Tactical microgrid initial conceptual design.

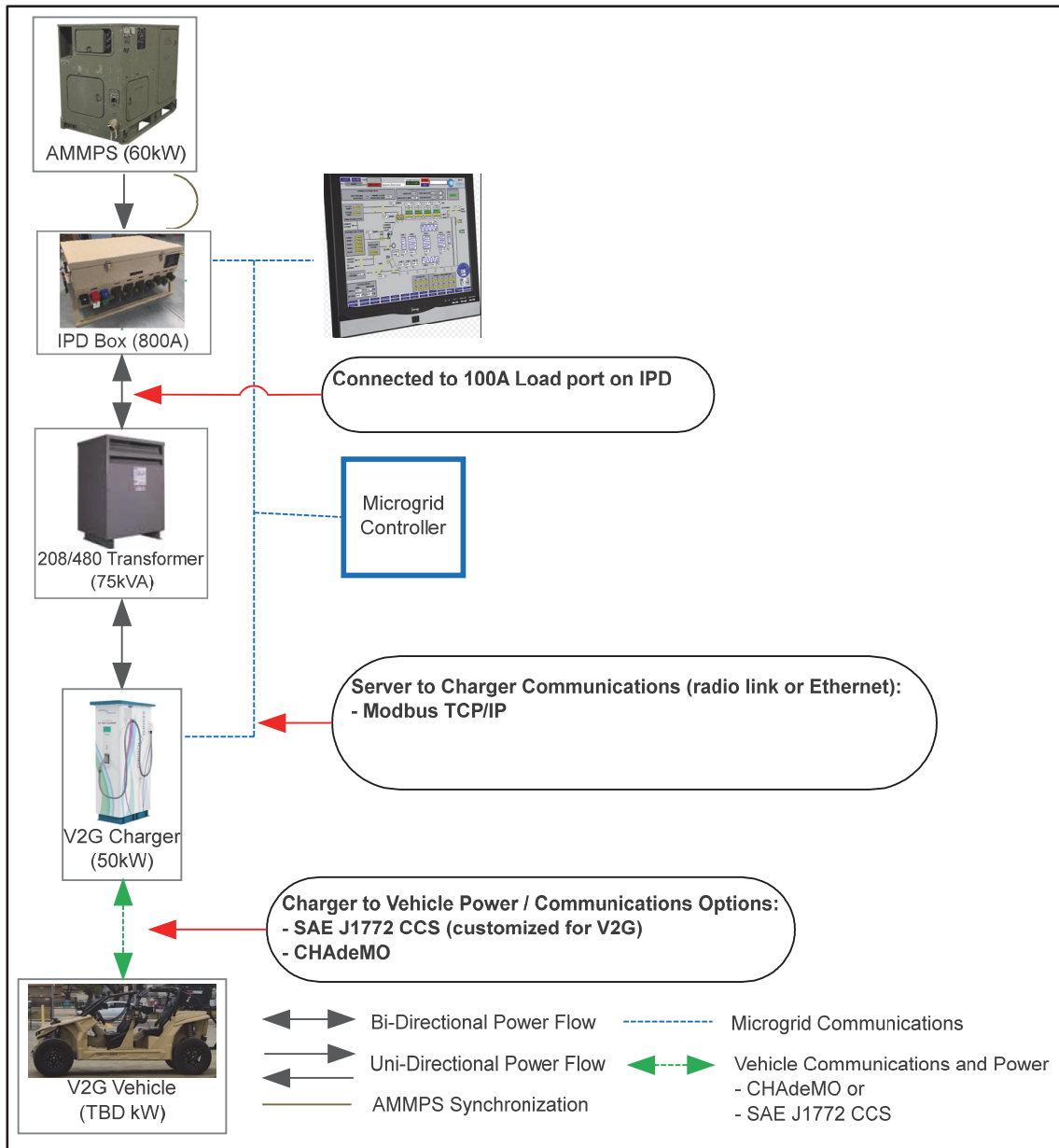

5.3 Computer simulation platform – simulate V2G charging in the tactical microgrid

5.3.1 Software models

A software model of the conceptual design using MATLAB/Simulink software provides the ability to simulate system performance with “what-if” scenarios. The MATLAB/Simulink microgrid model is scalable and includes model components that are designed to enable or disable “on-the-fly” reconfiguration. Each modeled component was selected to be

manufacturer agnostic to evaluate a technology’s energy resiliency support while avoiding the unnecessary complexity of specific manufacturer intricacies. Like the tactical microgrid it represents, the model is flexible, easy to configure, modular, and scalable.

The model expanded the initial conceptual design to include alternative-energy assets and is a key component of the living laboratory at CBITEC. The site includes a 100-kW PV Array, a 40-kWh energy storage system (ESS), a three-phase load bank, and billeting loads. Incorporating an ESS and a solar PV system into the model, with matching power and energy capabilities, enables representative model simulations to guide tactical microgrid integration and control design at CBITEC. In addition, the model can easily incorporate a utility connection to tactical microgrid simulations, which provides options to connect to host nation power or local generation stations. Model components can be enabled or disabled to accommodate numerous configurations and “what-if” scenarios tactical microgrids will inevitably encounter. A system model of the tactical microgrid is shown below in Figure 5-4.

Figure 5-4. System model of the tactical microgrid.

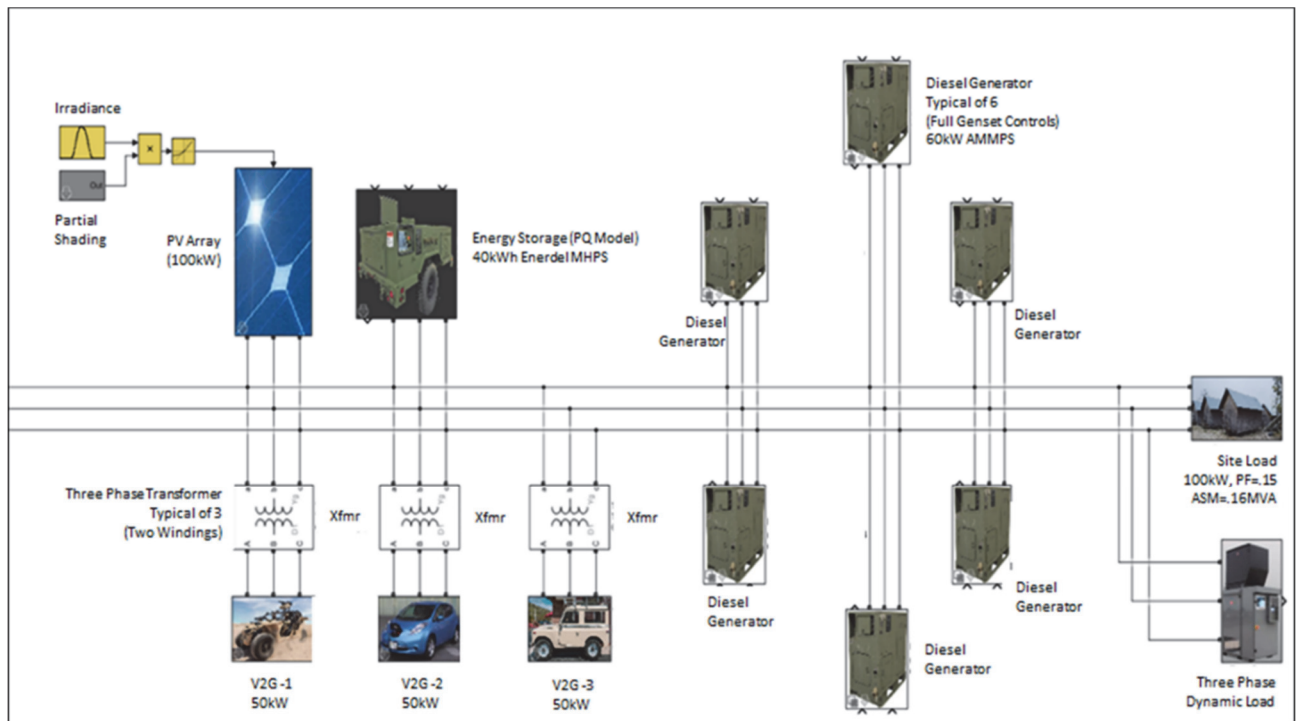

Individual software models of each microgrid component were developed with control logic to support control algorithm development. The individual models developed include:

- 60 kW AMMPS Generator
- 100 kW PV Array
- V2G fleet model with five vehicle types
- Lithium Ion Energy Storage
- Billet Load
- Dynamic Three-Phase Load Bank.

CBITEC site loads include the B-Huts and laundry facilities. The load model contains both resistive loads and motor loads to represent the motors starting and heating operation of the environmental control units feeding the B-Huts. The model is scalable and easily duplicated to reflect the billet load as a whole or to disable individual huts for load shedding schemes. The site load model is shown below in Figure 5-5.

Figure 5-5. Site load/billet model.

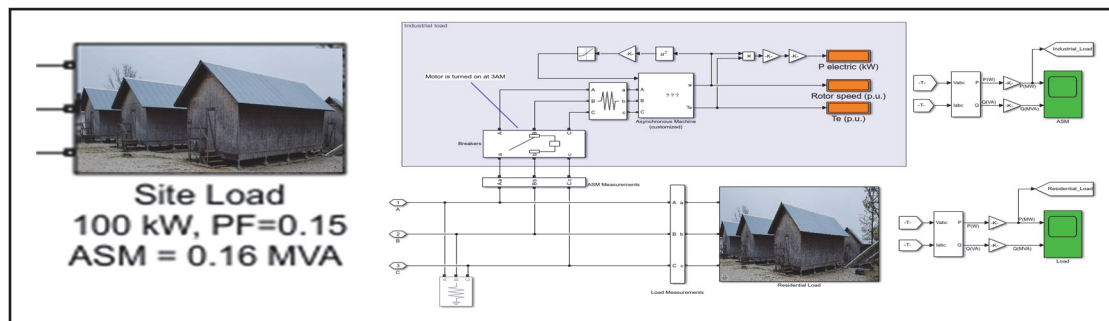

5.3.2 Recommended V2G voltage and frequency ride-through

The AMMPS generators can ride through severe voltage and frequency events, so the voltage and frequency tripping points of these generators should be set less restrictive than the PV array or V2G charger. As the AMMPS also dominates the grid voltage and frequency behaviors, and the PV and V2G are grid following, a ride-through voltage and frequency must be set for the PV and V2G to provide reliable operation.

The most common trip limits set into inverters are UL1741. The following Tables show the UL1741 disconnection points programmed into most inverters over 30 kW and anticipated to be enabled in most commercial

inverters. The inverters in the MATLAB model have frequency and voltage trip setpoints set at these values. See Table 5-2 and 5-3 for details.

Table 5-2. PV and V2G ride-through % base setpoints.

Voltage range (% base)	Clearing time (sec)
V<50%	0.16
50%<V<88%	2.00
110%<V<120%	1.00
V>120%	0.16

Table 5-3. PV and V2G ride-through Hz setpoints.

Frequency range (Hz)	Clearing time (sec)
Freq>61.8 Hz	0.16
Freq > 61 Hz	180
Freq<59 Hz	180
Freq<57 Hz	0.16

Therefore, to ensure proper coordination, the AMMPS generators should have voltage and frequency setpoints set as shown in Table 5-4 and 5-5.

Table 5-4. Generator ride-through % base setpoints.

Voltage range (% base)	Clearing time (sec)
V<50	1.16
50<V<88	3.00
110<V<120	2.00
V>120	1.16

Table 5-5. Generator ride-through Hz setpoints.

Frequency range (Hz)	Clearing time (sec)
Freq>60.5	1.16
Freq<59.8	101
Freq<57	1.16

5.4 Test plan to evaluate V2G performance

This section of the roadmap provides a test plan for demonstrating a V2G system within a tactical microgrid environment. The plan can validate that an electric vehicle is providing energy support to critical loads. The test plan can also validate the simultaneous interoperation of the EV with other generation sources while being dispatched as either a load or a generation source as needed to support efficient operation of the microgrid.

The test plan reflects the tactical microgrid model's manufacturer-agnostic and technology focus. The test plan can gauge a technology's ability to

support energy resilience for future use cases evaluated in the living laboratory. The test plan is designed to establish a baseline of the tactical microgrid consisting of AMMPS generators and site loading to quantify how those components respond to system anomalies, followed by integrating one V2G vehicle charging system, and repeating system anomalies to analyze which systems drop offline. The test plan assumes an operator dashboard previously provided to verify generator operation in a microgrid environment can be used for testing purposes.

The test plan includes establishing a microgrid operation baseline followed by connecting a 50-kW V2G system to be operated at four power levels (25% charge, 75% charge, 25% discharge, 75% discharge), inducing the same anomalies used for the baseline test at each power level. See Tables 5-6 and 5-7 for details.

Table 5-6. Test plan.

Step No.	Step Description	Use Case	V2G Setting	Load Bank Setting	Check
PRE	Visual Inspection to confirm: Fluids, warm engines	Baseline	N/A	N/A	
PRE	Verify all generators are off and ESTOPPED	Baseline	N/A	N/A	
PRE	Confirm IPD load bank, generator, and bus ports are all open	Baseline	N/A	N/A	
PRE	Confirm Site Loads and IPD load ports are open	Baseline	N/A	N/A	
PRE	Confirm all breakers on IPDs are open	Baseline	N/A	N/A	
PRE	Confirm all generators are ESTOPPED and stopped	Baseline	N/A	N/A	
PRE	Confirm all IPD bus and generator breakers/contactors are open	Baseline	N/A	N/A	
PRE	Confirm all generators are connected to IPDs generator ports per the configuration to be tested	Baseline	N/A	N/A	
PRE	Confirm V2G is connected to an IPD#1 load port	Baseline	N/A	N/A	
PRE	Confirm the load bank is connected to an IPD#2 load port	Baseline	N/A	N/A	
1	Hearing and eye protection on all participants	Baseline	N/A	N/A	
2	Start and close CB on Generator 1 (G1)	Baseline	N/A	N/A	
3	Confirm G1 MCCB closed on IPD1	Baseline	N/A	N/A	
4	Close 200A bus breaker for IPD1	Baseline	N/A	N/A	

Step No.	Step Description	Use Case	V2G Setting	Load Bank Setting	Check
5	Energize all bus ring and generator ports	Baseline	N/A	N/A	
6	Start and synchronize G1	Baseline	N/A	N/A	
7	Start and close CB on Generator 2 (G2)	Baseline	N/A	N/A	
8	Confirm G2 MCCB closed on IPD2	Baseline	N/A	N/A	
9	Close 200A bus breaker for IPD2	Baseline	N/A	N/A	
10	Energize all bus ring and generator ports	Baseline	N/A	N/A	
11	Start and synchronize G2	Baseline	N/A	N/A	
12	Set Load bank to 0 kW	Baseline	N/A	0 kW	
13	Close load port on IPD2	Baseline	N/A	0 kW	
14	Set Load bank to 60 kW	Baseline	N/A	60 kW	Observe frequency depression
15	Simultaneously adjust sourcing machines to achieve 60 Hz and equal load balance (achieve both control objectives simultaneously)	Baseline	N/A	60 kW	Note inter-dependencies between generator speed setpoints, power outputs, and system frequency
16	Open G1 port on IPD1	Baseline	N/A	60 kW	Islanding G1 – Observe no instabilities and load sharing continues
17	Close G1 port on IPD1	Baseline	N/A	60 kW	Reconnecting G1, G2 via IPD1 and IPD2
18	Open G2 port on IPD2	Baseline	N/A	60 kW	Islanding G2 – Observe no instabilities and load sharing continues
19	Close G2 port on IPD2	Baseline	N/A	60 kW	Reconnecting G1, G2 via IPD1 and IPD2
20	Close V2G port on IPD1	Baseline	N/A	60 kW	Observe system voltage and frequency stability
21	Set V2G charging at 12.5 kW (25% load)	Baseline	Charging 12.5 kW	60 kW	Observe system voltage and frequency stability
22	Set V2G charging at 37.5 kW (75% load)	Baseline	Charging 37.5kW	60 kW	Observe system voltage and frequency stability
23	Set V2G charging at 0 kW	Baseline	Charging 0 kW	60 kW	Observe system voltage and frequency stability
24	Set V2G discharging at 12.5 kW (25% load)	Baseline	Discharging 12.5 kW	60 kW	Observe system voltage and frequency stability
25	Set V2G discharging at 37.5 kW (75% load)	Baseline	Discharging 37.5 kW	60 kW	Observe system voltage and frequency stability
26	Open G1 port on IPD1	Sudden Generation Decrease	Discharging 37.5 kW	60 kW	Observe system voltage and frequency stability
27	Close G1 port on IPD1	Sudden Generation Increase	Discharging 37.5 kW	60 kW	Observe system voltage and frequency stability and V2G operational status
28	Open G2 port on IPD2	Sudden Generation Decrease	Discharging 37.5 kW	60 kW	Observe system voltage and frequency stability and V2G operational status

Step No.	Step Description	Use Case	V2G Setting	Load Bank Setting	Check
29	Close G2 port on IPD2	Sudden Generation Increase	Discharging 37.5 kW	60 kW	Observe system voltage and frequency stability and V2G operational status
30	Set V2G charging to 50 kW (100%)	Sudden Load Increase	Charging 50 kW	60 kW	Observe system voltage and frequency stability and V2G operational status
31	Decrease Load Bank from 50 kW to 0 kW	Sudden Load Decrease	Charging 50 kW	0 kW	Observe system voltage and frequency stability and V2G operational status
32	Decrease G1 to 0 kW	Sudden Generation Decrease	Charging 50 kW	0 kW	Observe system voltage and frequency stability and V2G operational status
33	Increase G1 to 50 kW	Sudden Generation Increase	Charging 50 kW	0 kW	Observe system voltage and frequency stability and V2G operational status
34	Increase Load Bank from 0 kW to 50 kW	Sudden Load Increase	Charging 50 kW	50 kW	Observe system voltage and frequency stability and V2G operational status
35	Decrease G1 to 0 kW	Sudden Generation Decrease	Charging 50 kW	50 kW	Observe system voltage and frequency stability and V2G operational status
36	Increase G1 to 50 kW	Sudden Generation Increase	Charging 50 kW	50 kW	Observe system voltage and frequency stability and V2G operational status
37	Set V2G for discharging at 40 kW	Sudden Generation Increase	Discharging 40 kW	50 kW	Observe system voltage and frequency stability and V2G operational status
38	Increase Load Bank from 50 kW to 100 kW	Sudden Load Increase	Discharging 40 kW	100 kW	Observe system voltage and frequency stability and V2G operational status
39	Decrease Load Bank from 100 kW to 50 kW	Sudden Load Decrease	Discharging 40 kW	50 kW	Observe system voltage and frequency stability and V2G operational status
40	Set V2G to charge at 0 kW	Test End	0 kW	50 kW	
41	Set Load bank to 0 kW	Test End	0 kW	0 kW	
42	Open both bus ports A&B on IPD1	Test End	0 kW	0 kW	
43	Open both bus ports A&B on IPD2	Test End	0 kW	0 kW	
44	Reset (open) all IPD breakers All load banks offline EStop all generators	Test End	0 kW	0 kW	

Table 5-7. Test plan conditions.

Test Condition	V2G Charging Steps	V2G Discharging Steps
Sudden generation decrease	32, 35	26, 28
Sudden generation increase	33, 36	27, 29, 37
Sudden load decrease	31	39
Sudden load increase	30, 34	38

The anomalies considered are a sudden loss of generation and load, and a sudden increase in generation and load. In addition, the test plan includes a sudden loss of the V2G system at 100-percent charge and discharge to evaluate system impact with the loss of the V2G resource. This manufacturer-agnostic approach focuses on generation source ability under test to consume or produce energy supporting the tactical microgrid. The test plan tests V2G charger response during charge and discharge modes for sudden increases and decreases for both generation and load (Figure 5-6).

Figure 5-6. Test plan configuration.

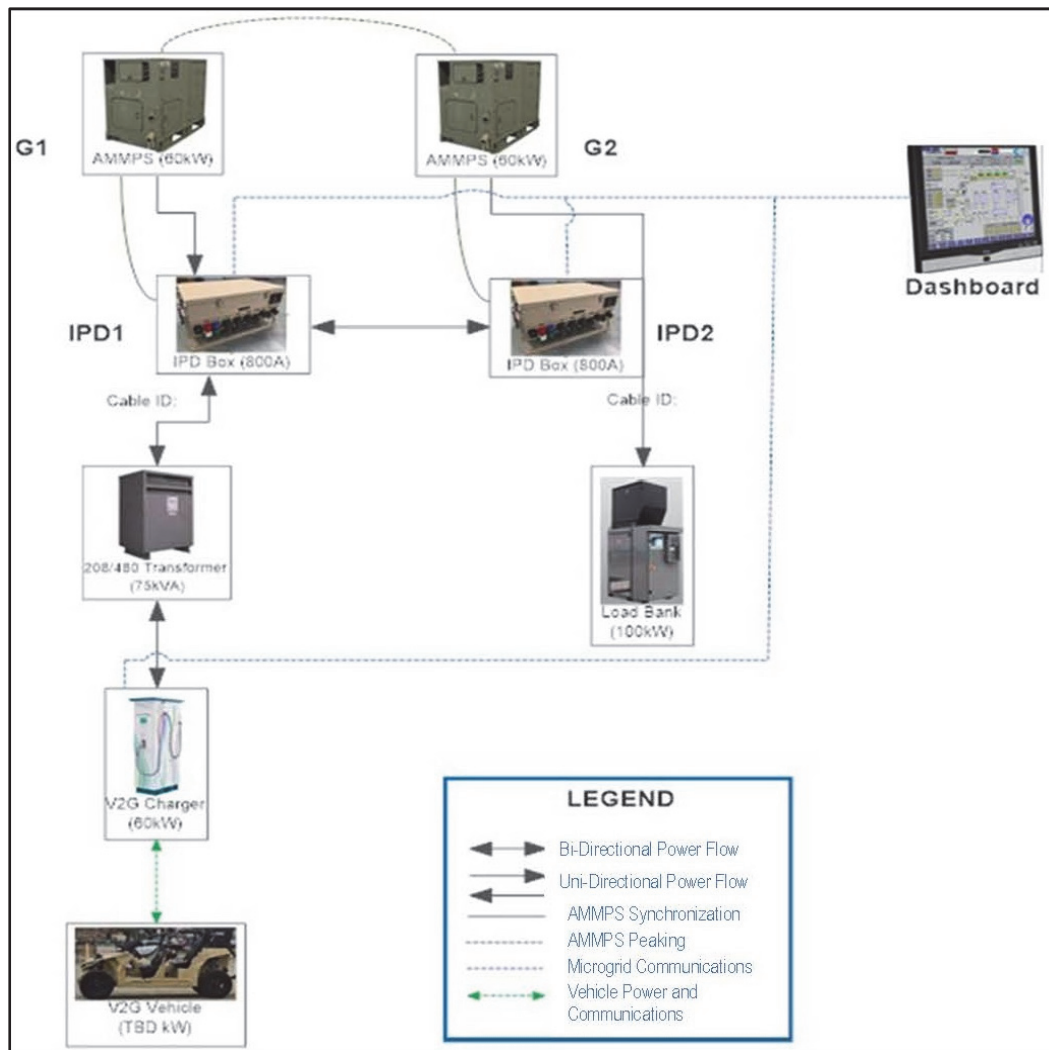

5.5 Tactical microgrid model with Coritech V2G charger

The Coritech VGI-30-DC-CHA fast charger was selected based on program objectives and site requirements. The VGI-30-DC-CHA fast charger is

CHAdEMO compliant and is suitable for integrating into a tactical microgrid because it:

- Has an AC voltage configuration that easily integrates into the planned 208-VAC microgrid distribution system with a COTS step-down transformer
- Is specifically designed for fast charging and discharging of a CHAdEMO-compliant vehicle
- Uses open protocols to interface with an overarching controller to monitor and control the charging and discharging rates of the EV
- Uses open protocols, commonly used to interface with EVs, including the Nissan LEAF
- Is designed to U.S. standards applicable to V2G charging systems and distributions systems rated for use in the U.S.
- Is designed to operate outdoors.

Modeling results demonstrated that this Coritech V2G charger will interoperate with the military legacy equipment that make up the CBITEC tactical microgrid. Anticipated voltage and frequency variations of the AMMPS generators, produced by the sudden increases or decreases in load or generation, are not expected to cause nuisance trips for the charger.

The IPD developed by HG Engineers, combined with the wireless mesh network and the Modbus protocol, provides a baseline for system communication requirements and future device integration and interoperability. The 3e-523-3 wireless access points manufactured by 3e TI Technology International and the established wireless mesh network at CBITEC are cyber secure and already approved for use on a SIPRNet.

Future research recommendations regarding the development of the CBITEC tactical microgrid are as follows: complete a detailed design of the tactical microgrid, document IPD and hardware settings for interconnecting the microgrid assets and include hardware-in-the-loop modeling and testing to improve simulation accuracy, and support control algorithm development.

5.6 Interoperability and standards gap analysis

Electrical utilities require compliance with the UL1741 standard, which requires generation sources to disconnect from the electrical grid during a

grid outage. The goal of this requirement is to mitigate the risk of personnel tasked to restore grid operations. Devices that are UL1741 compliant, including V2G fast chargers, are required to disconnect based on voltage and frequency deviations as identified in the UL1741 standard. The CBITEC tactical microgrid model validated that UL1741 compliant devices will nuisance trip in an AMMPS-based microgrid, based upon default trip settings. Recommended solutions to overcome this gap in standards include use of the CHAdeMO standard for a proof-of-concept demonstration and adjusting trip settings for AMMPS generators and V2G inverters to allow ride-through. Future demonstrations should consider utilization of purpose-built power converter/energy storage systems for tactical microgrids using open standards (Modbus, CANbus) to monitor and control equipment interoperability.

6 Summary

The CBITEC Living Laboratory is the convergence of two distinct but overlapping areas of research: (1) a sensed living laboratory to assess the performance of autonomous transport vehicles and (2) an interoperable living laboratory to assess V2G charging in a tactical microgrid.

The research outcomes and project deliverables provide the roadmap for the living laboratory as demonstrated in Figures 6-1, 6-2, 6-3 and 6-4.

Figure 6-1. Roadmap for the sensor plan for CBITEC and TA231.

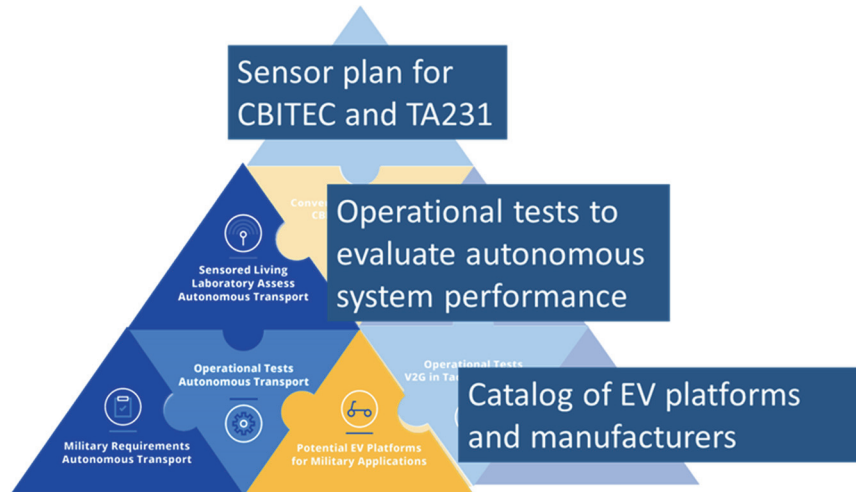

Figure 6-2. Roadmap for the Coritech V2G charging station.

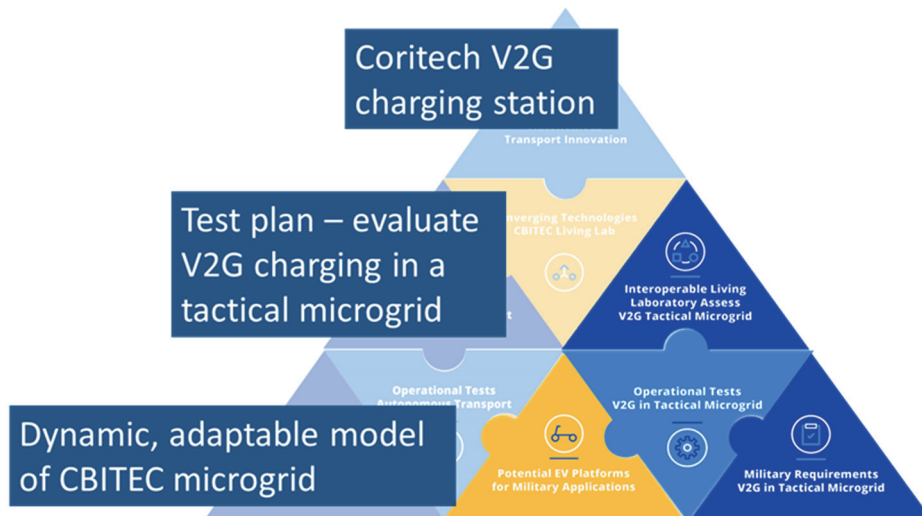

Figure 6-3. Roadmap for the autonomous electric and tactical microgrid technologies.

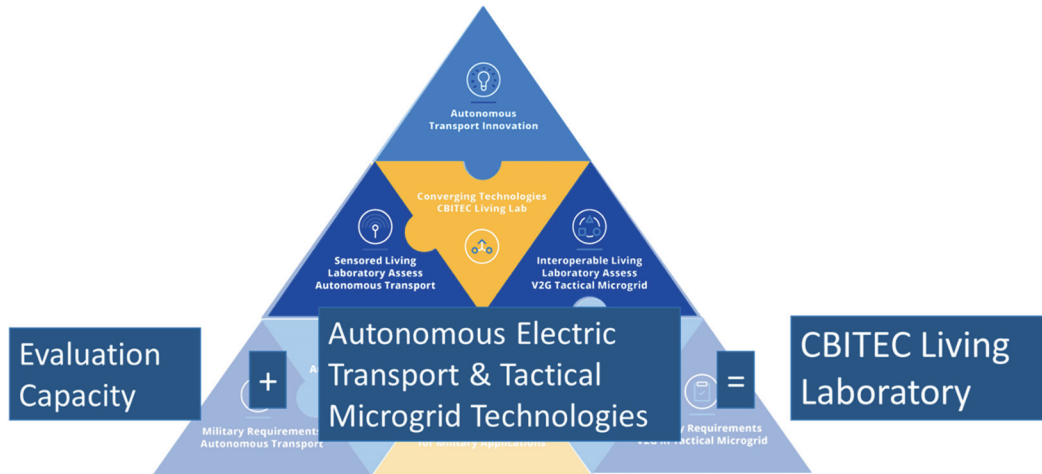
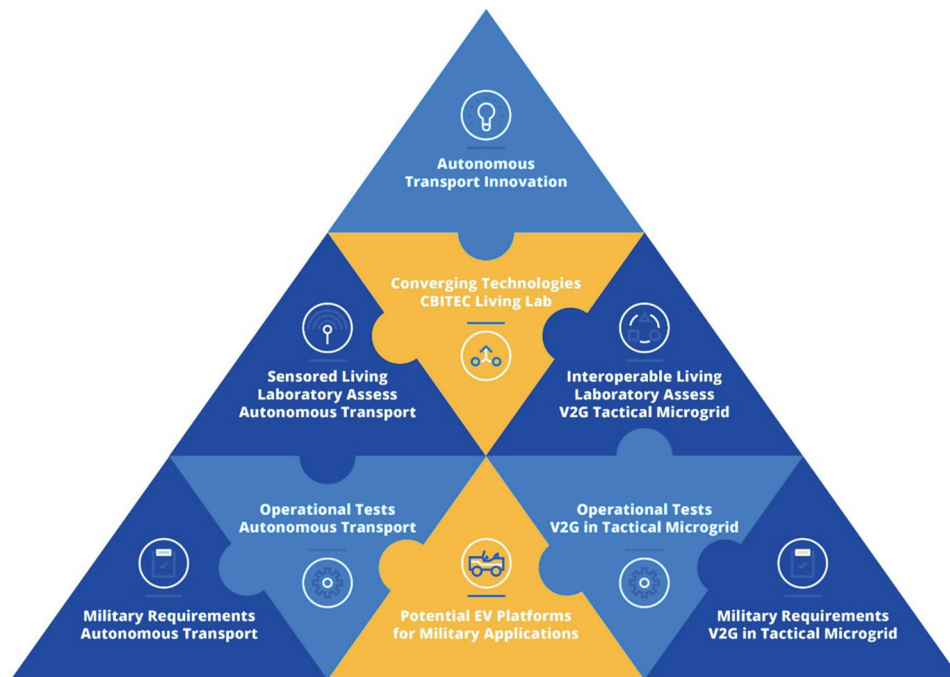

Figure 6-4. Roadmap for autonomous transport innovation.



The Paragon team has developed the roadmap for an innovative sensed, living laboratory that can evaluate emerging electric transport vehicles, vehicle autonomy, V2G charging, and microgrid technologies. The fundamental basis of the living laboratory is to serve as a testbed to facilitate joint research and evaluation of autonomous EVs and bi-directional-vehicle charging in a real-world, non-hostile environment. The living laboratory will leverage government and industry technical expertise to

accelerate technological advancement and innovation. The collaborative environment between the Paragon and CERL teams culminated in information sharing and open innovation across technology borders that might otherwise be siloed. The living laboratory is therefore also a platform for collaborative innovation by leaders in these fields.

Bibliography

110th Congress. "TITLE XIII—SMART GRID." Energy Independence and Security Act of 2007 [Public Law No: 110-140]. 2017. pp. 293–294. <https://www.congress.gov/110/plaws/publ140/PLAW-110publ140.pdf>.

"2018 ERDC BROAD AGENCY ANNOUNCEMENT (BAA), CERL-4 and CERL-6 U.S. Army Corps of Engineers, USACE ITL, GSL, EL, CHL, Vicksburg, MS." Federal Business Opportunities, FBO-5916, Solicitation W912HZ-18-BAA-01. 2018. <https://www.fbo.gov/spg/USA/COE/329/W912HZ-18-BAA-01/listing.html>.

"CERL Missions." U.S. Army Corps of Engineers Engineer Research and Development Center Construction Engineering Research Lab. 2021. www.erd.usace.army.mil/Locations/CERL/Missions.aspx.

Cyber & Infrastructure Security Agency. "Critical Infrastructure Sectors." U.S. Department of Homeland Security. 2019. www.cisa.gov/critical-infrastructure-sectors.

"Energy Security & Sustainability (ES2) Strategy." U.S. Army. 2015. <https://api.army.mil/e2/c/downloads/394128.pdf>.

General Mark Milley, Army Chief of Staff, Honorable Mark Esper, Secretary of the Army. 2019. "Army 2028 Mission and Vision Statement." pp. 7.

GridWise™ Architecture Council. 2005. "GridWise Architecture Council Interoperability Constitution Whitepaper." GridWise™ Architecture Council. https://www.gridwiseac.org/pdfs/interoperability_path_whitepaper_v1_o.pdf.

Henry, Capt. Matthew P. "Autonomous Transportation: Combat Power in the 21st Century." U.S. Army. 2018. army.mil/article/213078/autonomous_transportation_combat_power_in_the_21st_century.

Lafontaine, Dan. "Army takes key step in enabling interoperability of multinational power systems." CCDC C5ISR Center Public Affairs. 2019. https://www.army.mil/article/223713/army_takes_key_step_in_enabling_interoperability_of_multinational_power_systems.

Vehicle-Grid Integration Communications Protocol Working Group. "DRIVE OIR Vehicle-Grid Integration Working Group." California Public Utilities Commission. 2021. www.cpuc.ca.gov/vgi/.

REPORT DOCUMENTATION PAGE

Form Approved
OMB No. 0704-0188

Public reporting burden for this collection of information is estimated to average 1 hour per response, including the time for reviewing instructions, searching existing data sources, gathering and maintaining the data needed, and completing and reviewing this collection of information. Send comments regarding this burden estimate or any other aspect of this collection of information, including suggestions for reducing this burden to Department of Defense, Washington Headquarters Services, Directorate for Information Operations and Reports (0704-0188), 1215 Jefferson Davis Highway, Suite 1204, Arlington, VA 22202-4302. Respondents should be aware that notwithstanding any other provision of law, no person shall be subject to any penalty for failing to comply with a collection of information if it does not display a currently valid OMB control number. PLEASE DO NOT RETURN YOUR FORM TO THE ABOVE ADDRESS.

1. REPORT DATE (DD-MM-YYYY) September 2021			2. REPORT TYPE Final Technical Report (TR)		3. DATES COVERED (From - To)	
4. TITLE AND SUBTITLE Autonomous Transport Innovation (ATI): Integration of Autonomous Electric Vehicles into a Tactical Microgrid			5a. CONTRACT NUMBER W9132T19C0003		5b. GRANT NUMBER	
			5c. PROGRAM ELEMENT		5d. PROJECT NUMBER 6LKD1G	
			5e. TASK NUMBER		5f. WORK UNIT NUMBER 6LKD1G	
6. AUTHOR(S) Angela Rolufs, Amelia Trout, Kevin Palmer, Clark Boriack, Bryan Brillhart and Annette L. Stumpf			7. PERFORMING ORGANIZATION NAME(S) AND ADDRESS(ES) U.S. Army Engineer Research and Development Center (ERDC) Construction Engineering Research Laboratory (CERL) PO Box 9005, Champaign, IL 61826-9005		8. PERFORMING ORGANIZATION REPORT NUMBER ERDC/CERL TR-21-21	
9. SPONSORING / MONITORING AGENCY NAME(S) AND ADDRESS(ES) Headquarters, U.S. Army Corps of Engineers 441 G St., NW Washington, DC 20314-1000			10. SPONSOR/MONITOR'S ACRONYM(S) HQUSACE		11. SPONSOR/MONITOR'S REPORT NUMBER(S)	
12. DISTRIBUTION / AVAILABILITY STATEMENT Approved for public release; distribution is unlimited.						
13. SUPPLEMENTARY NOTES						
14. ABSTRACT The objective of the Autonomous Transport Innovation (ATI) technical research program is to investigate current gaps and challenges then develop solutions to integrate emerging electric transport vehicles, vehicle autonomy, vehicle-to-grid (V2G) charging and microgrid technologies with military legacy equipment. The ATI research area objectives are to: identify unique military requirements for autonomous transportation technologies; identify currently available technologies that can be adopted for military applications and validate the suitability of these technologies to close need gaps; identify research and operational tests for autonomous transport vehicles; investigate requirements for testing and demonstrating of bidirectional vehicle charging within a tactical environment; develop requirements for a sensed, living laboratory that will be used to assess the performance of autonomous innovations; and integrate open standards to promote interoperability and broad-platform compatibility. The research performed resulted in an approach to develop a sensed, living laboratory with operational testing capability to assess the safety, utility, interoperability, and resiliency of autonomous electric transport and V2G technologies in a tactical microgrid. The living laboratory will support research and assessment of emerging technologies and determine the prospect for implementation in defense transport operations and contingency base energy resilience.						
15. SUBJECT TERMS Automated vehicles—Technology; Electric Vehicles—Technology; Microgrids (Smart power grids); Transportation; Safety						
16. SECURITY CLASSIFICATION OF:			17. LIMITATION OF ABSTRACT SAR	18. NUMBER OF PAGES 55	19a. NAME OF RESPONSIBLE PERSON	
a. REPORT Unclassified	b. ABSTRACT Unclassified	c. THIS PAGE Unclassified			19b. TELEPHONE NUMBER (include area code)	