



# AFRL/RQ & AFLCMC/XZ CONTRIBUTIONS TO GMGW-2 CASE 3: OPAM-1 PARAMETRIC REMESHING PARTICIPANT ID 5

2ND AIAA GEOMETRY AND MESH GENERATION WORKSHOP  
JANUARY 5-6, 2019  
SAN DIEGO, CA

**MICHAEL T. FREDE AND SCOTT E. SHERER**  
AEROSPACE SYSTEMS DIRECTORATE

**JAMES "BEN" LEWIS**  
AIR FORCE LIFE CYCLE MANAGEMENT CENTER

---

(Case Number 88ABW-2018-6310, 18 Dec 2018)

DISTRIBUTION STATEMENT A. Approved for public release. Distribution is unlimited.

## OUTLINE

- Background
  - Tools/Approach
  - User Background
  - Geometry Import and Preparation
  - Mesh Generation
- Surface Components
  - Fuselage
  - Wing
  - Vertical/Horizontal Tails
  - Pod/Pylon
- Design Iterations/Mesh Evaluation
  - Case 3a (baseline)
  - Case 3b (wide body)
  - Case 3c (increased wing sweep)
  - Case 3d (relocate pylon/pod)
  - Case 3e (narrow pod/short pylon)
- Gridding Issues and Challenges
- Future Topics
- Conclusions / Summary

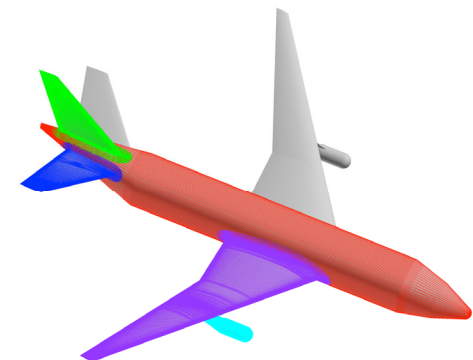
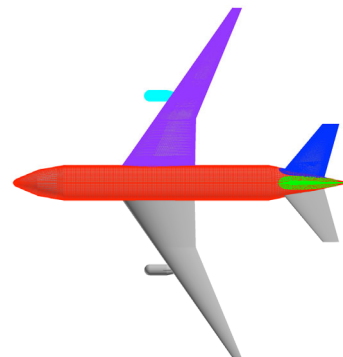
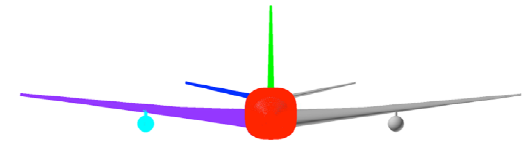
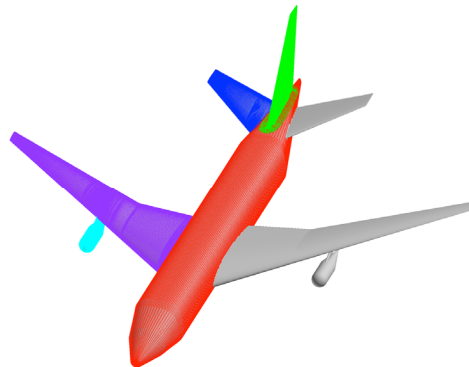

# BACKGROUND

## BACKGROUND

- Approach - Structured overset grids developed using parameterized scripts
- User Experience
  - Two “expert” users, one of which is currently using tools on a daily basis on complex configurations
  - One “novice” user looking to develop more experience with structured overset grid generation
- Goals
  - Further expert users’ experience with writing and employing scripts on full aircraft configurations
  - Refine techniques to generate grids in a “design” environment
  - Evaluate as a training case to expose new (and future) users to application of tools on realistic problem
- Geometry Import and Preparation
  - Process
    - Normal process is CADFIX -> STL -> TRI -> Grid generation
    - Analytically defined surfaces here so geometry prep was minimal
  - Difficulties
    - One of the CGT built-in scripts had an issue due to it being employed in a non-standard way and will be discussed later
  - Modifications
    - Some minor modifications to geometry due to differences between analytic definition and provided CAD file (details in Backup slides)

## BACKGROUND

- Mesh Generation
  - Process – Chimera Grid Tools for grid generation and PEGASUS 5.2b for overset grid connectivity and hole cutting (NASA)
    - TCL scripts written to analytically define all geometry
    - All grids generated analytically except for collar grids, which were typically projected onto the analytic grids of the components that the collar spanned
  - Difficulties
    - Very powerful process for generating geometry and grids that can be modified parametrically, but there is a steep learning curve
    - Initial scripts can be time consuming to write

```

48 set Par(ds,az)           0.025
49 set Par(geom,height)    15
50 set Par(ds,length,center) 0.05
51 set Par(ds,length,end)  0.005
52 set Par(ds,length,cap)  0.01
53 set Par(sr,height)      1.1
54
55 set Par(geom,angley)     45.
56 set Par(geom,anglex)    45.
57
    
```

← Parameterization of key variables

Utilization of existing  
functionality for CGT  
Script Library →

```

...
127 # Make initial curve of sphere
128 CreateCurve 3 p3d curve.1 $dim_lat 0.0 $pi "$Par(geom,radius)*cos(t)"
129 # Convert to multiple-grid and then to unformatted
130 P3Ds2m curve.1 curve.2
131 P3DForm2Unform curve.2 curve.1
132
133 # Revolve curve about x-axis by 360 degrees to generate geometry
134 GedRevolve curve.1 sphere.1 x 360. 1 $dim_long [list 1]
...
    
```

# SURFACE COMPONENTS

# FUSELAGE

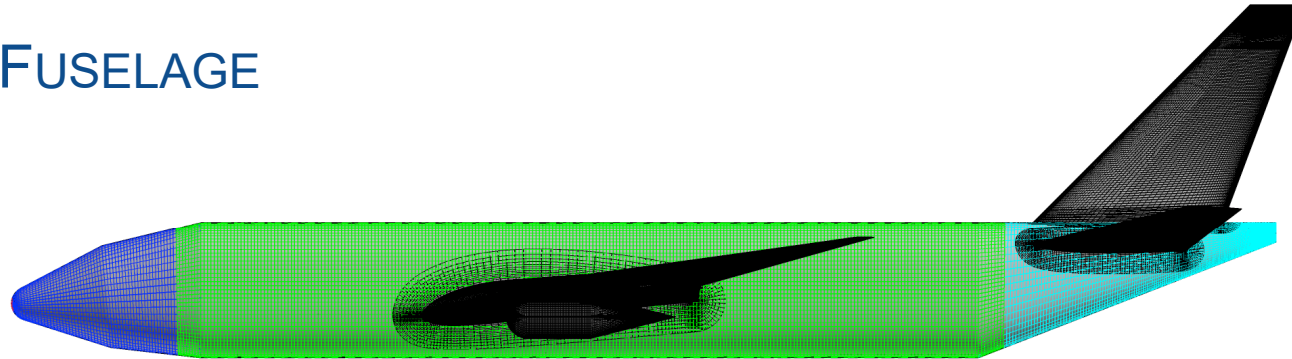

Blue nose grid expands as it reaches fuselage,  
Green grid halves the spacing to maintain aspect ratio  
Teal grid doubles spacing in transition from fuselage to tail

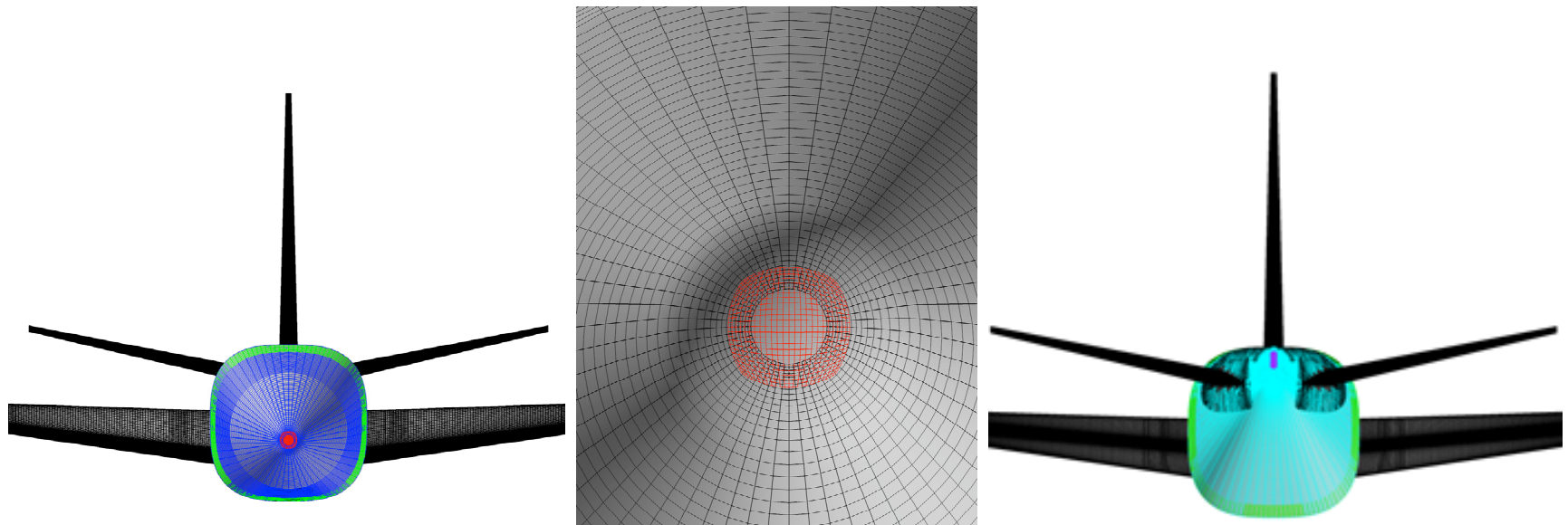

Red nose cap grid grows until spacing approximately matches blue grid

WINGS

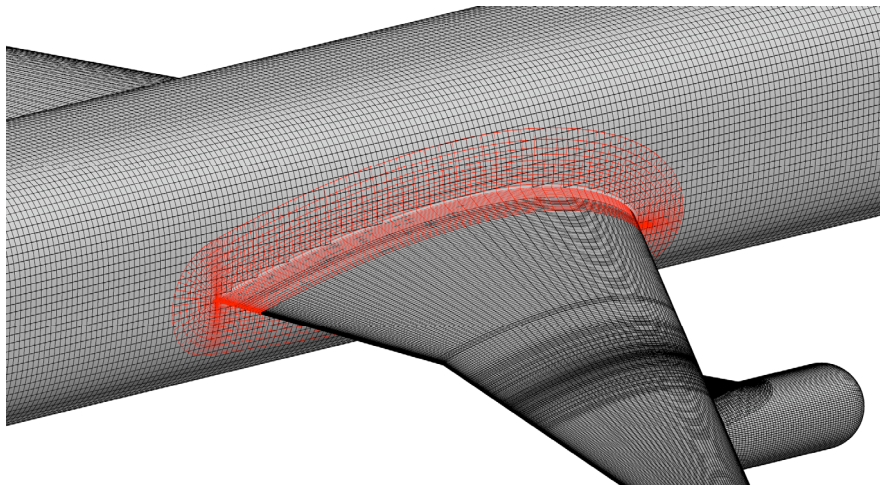
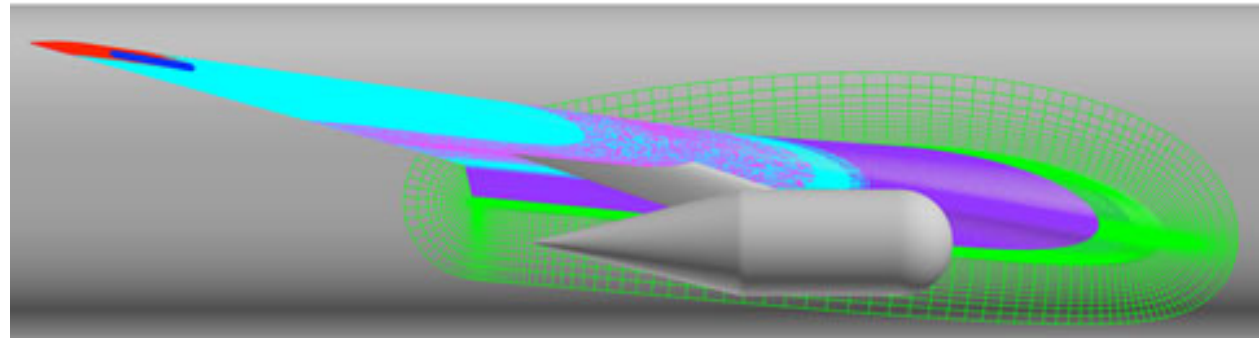
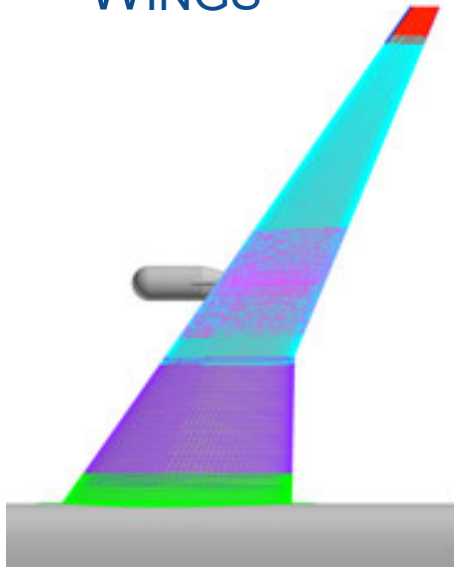

- Inboard, outboard and collar grids
- Variable-position refined grid to align pylon/wing spacing
- Multiple grids make up wing-tip system (next slide)

## WING TIP

Typical wing tip topology has highly skewed cells in corner

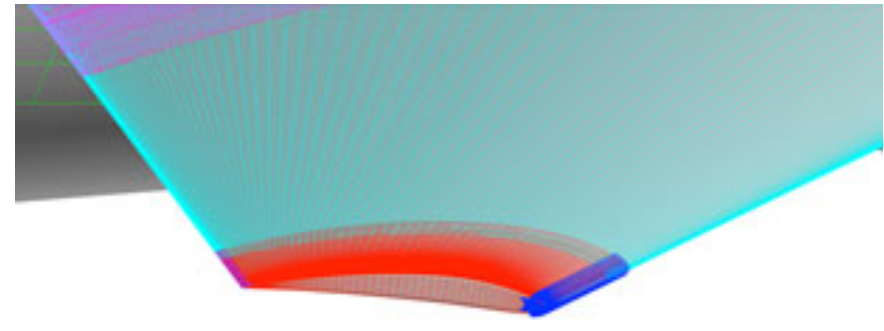
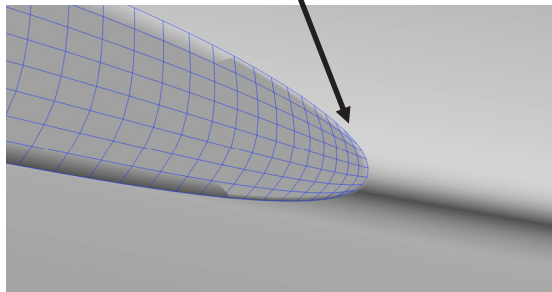

Three grids make up wing tips

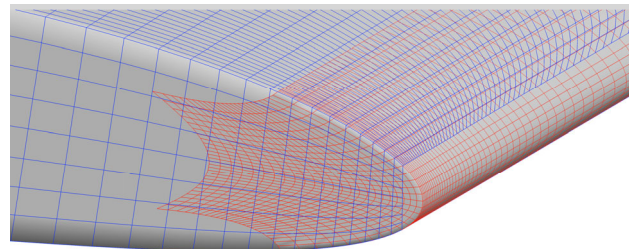

- Can also be used in combination with attached LE and TE grids and then grown on the upper and lower surfaces to form a single grid covering the wing tip similar to below
- Growing onto surface tends to follow curvature of that surface, creating a grid that pulls away from the LE

## HORIZONTAL AND VERTICAL TAILS

- Inboard, tip (LE, TE wrap-around)
- Part of collar grid projected onto tail surface and part projected onto fuselage
- Same topology used on vertical and both horizontal tails (same basic topology as full wing-grid)

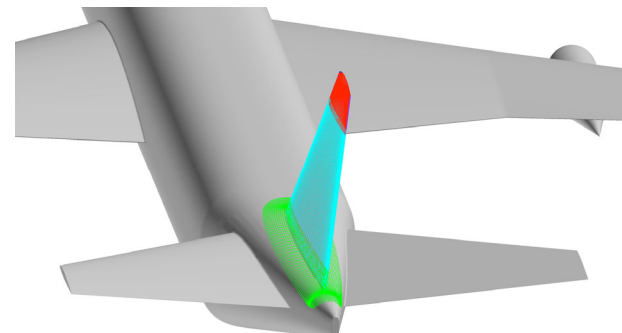
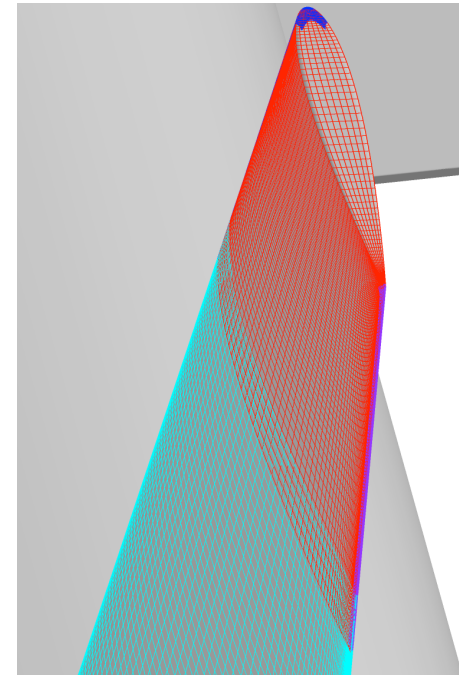
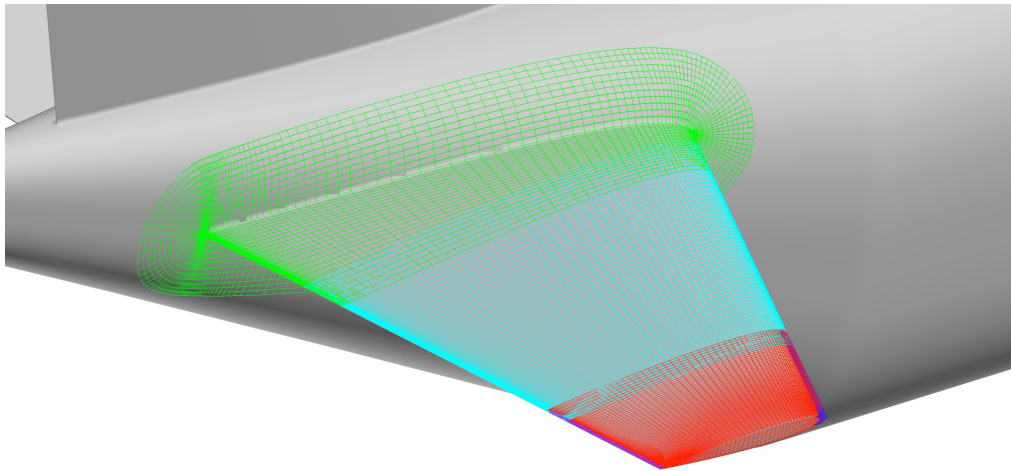

POD/PYLON

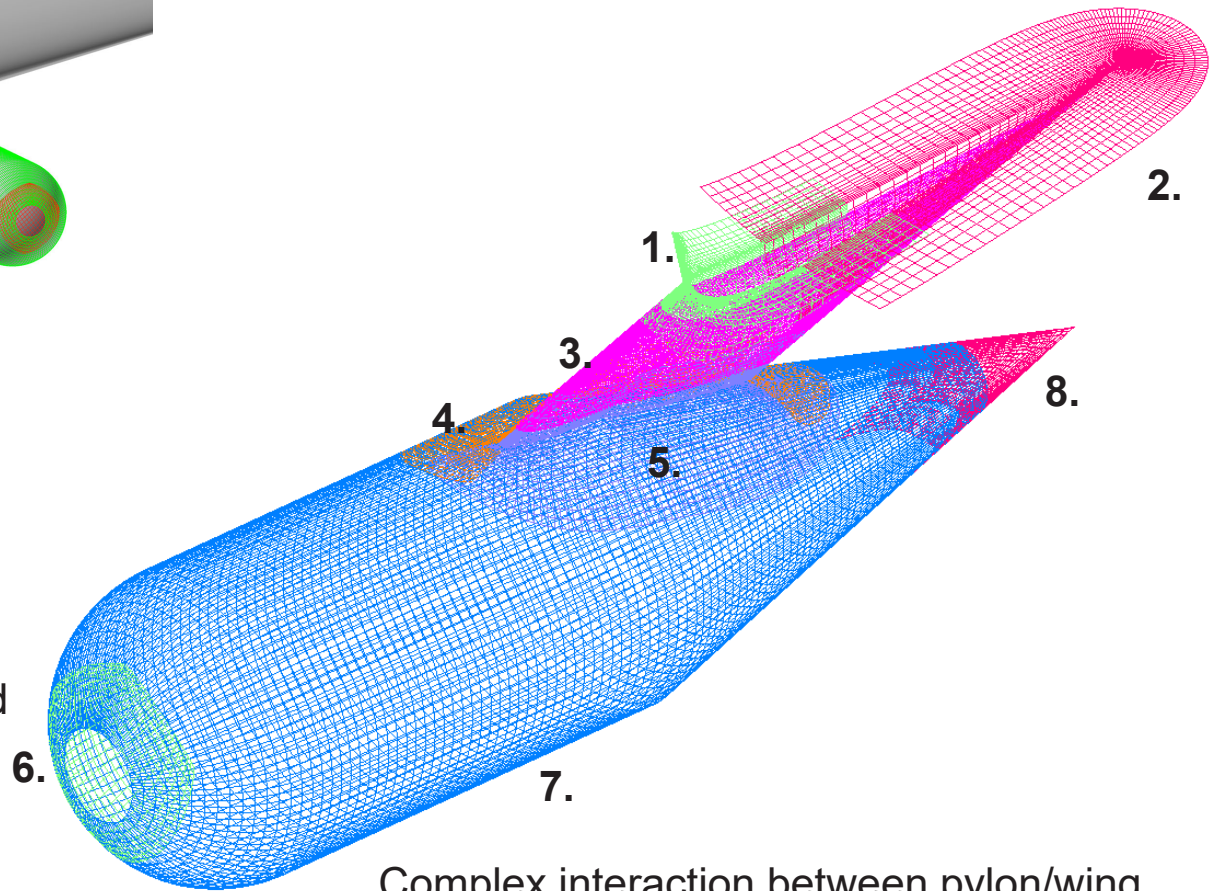
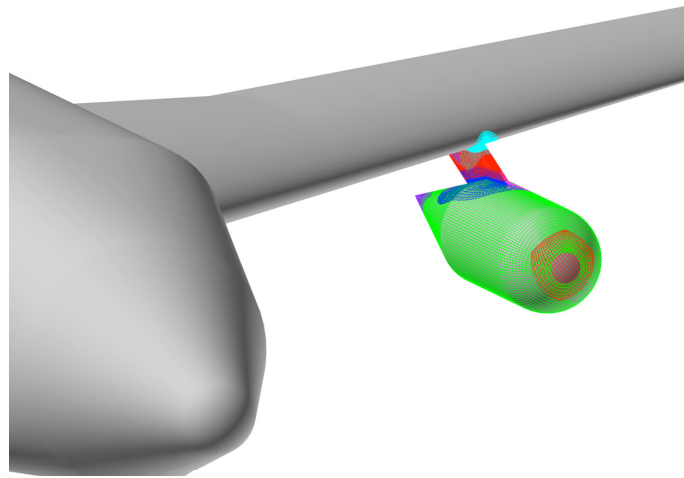

- 1. LE collar grid pylon / wing
- 2. TE collar grid pylon / wing
- 3. Pylon grid
- 4. Starboard collar grid pylon / pod
- 5. Port collar grid pylon / pod
- 6. LE Pod cap grid
- 7. Pod body grid
- 8. TE Pod cap grid

Complex interaction between pylon/wing and pylon/pod required collar grid to be split into multiple components

# DESIGN ITERATIONS

## CASE 3A - BASELINE

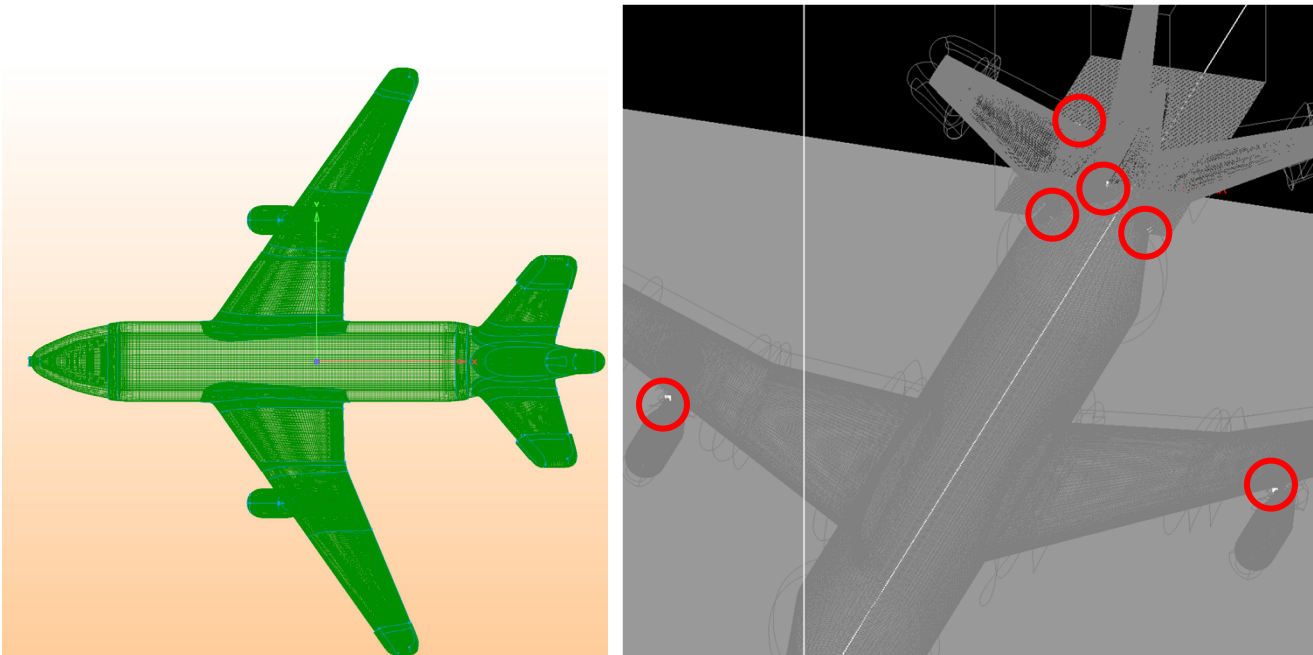

- 52 overset volume grids
  - 279 overlapping surface grids
  - 40.3M cells
- 12 orphans

### Cell count

	Selection	Entire Grid
<b>Connectors</b>		
Total Cells	49,584	49,584
Total Points	49,384	49,384
<b>Domains</b>		
Triangles	0	0
Quads	2,479,648	2,479,648
Total Cells	2,479,648	2,479,648
Total Points	2,476,095	2,476,095
<b>Blocks</b>		
Tets	0	0
Pyramids	0	0
Prisms	0	0
Hexes	40,268,928	40,268,928
Total Cells	40,268,928	40,268,928
Total Points	41,440,705	41,440,705

Close

# CASE 3A - BASELINE

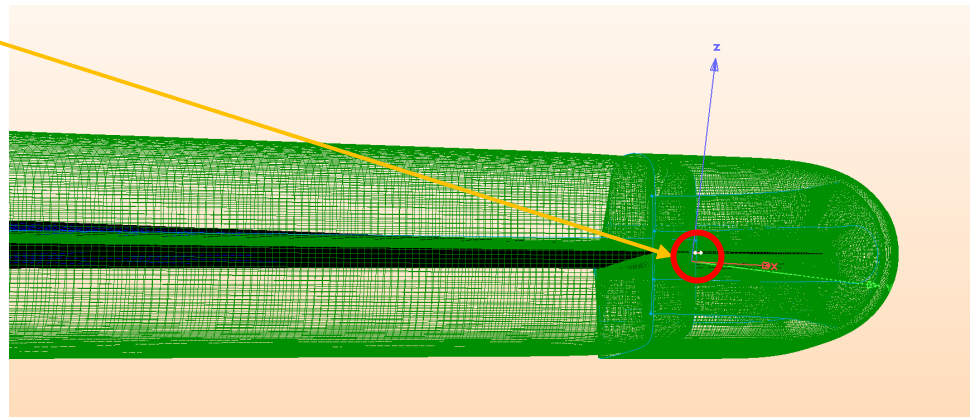
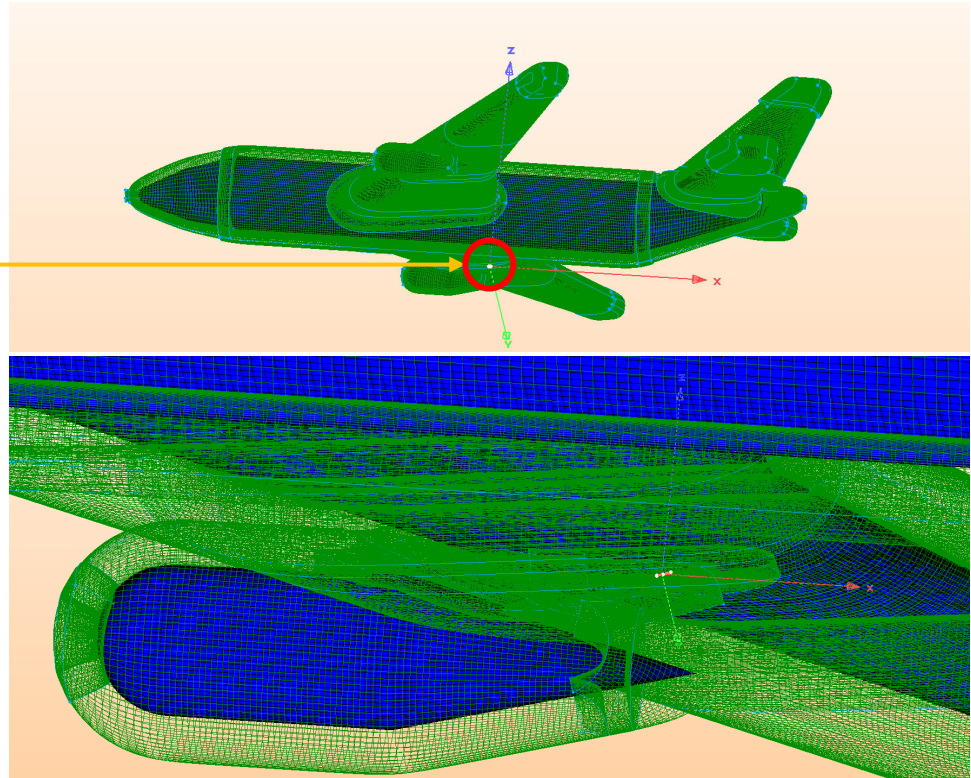
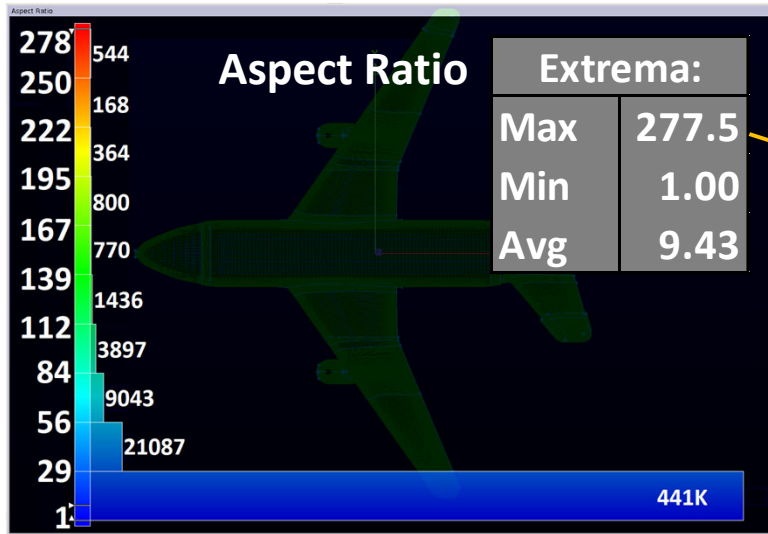
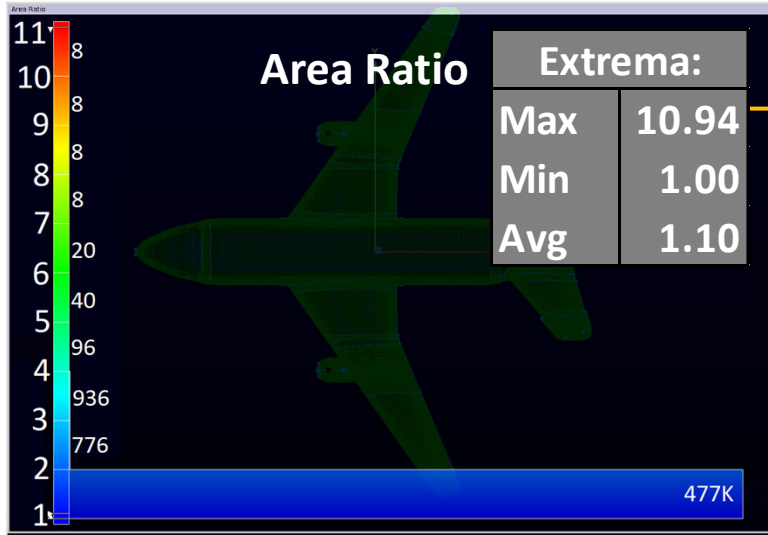

# CASE 3A - BASELINE

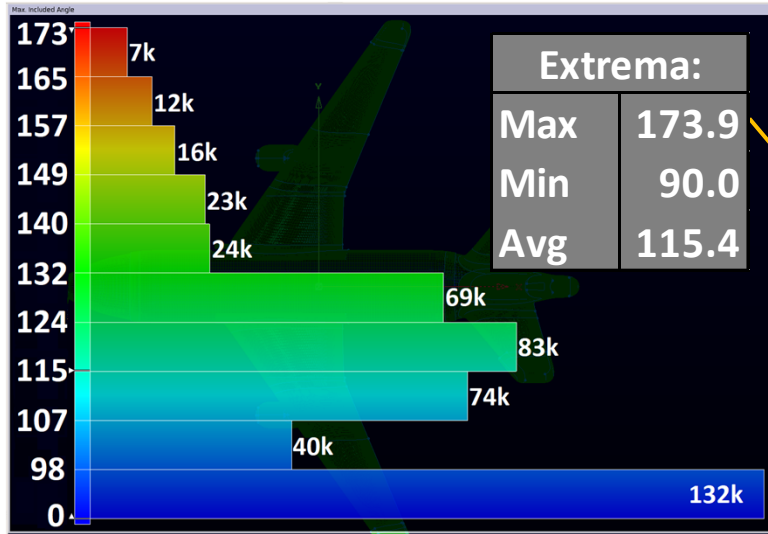

Max Included Angle

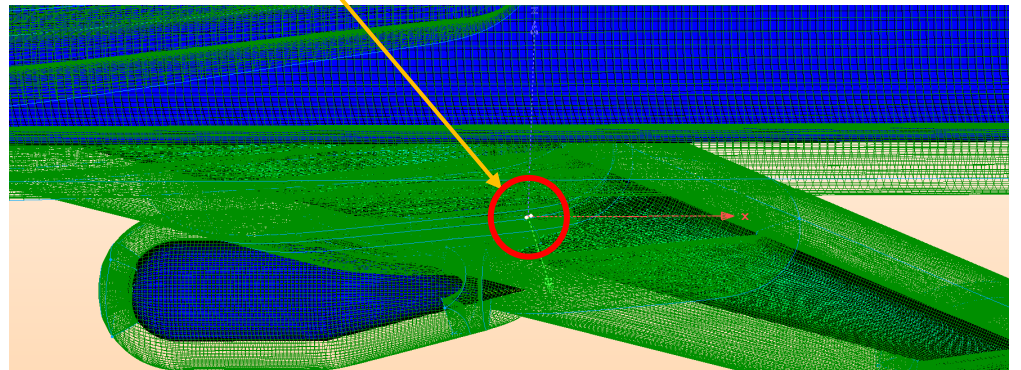
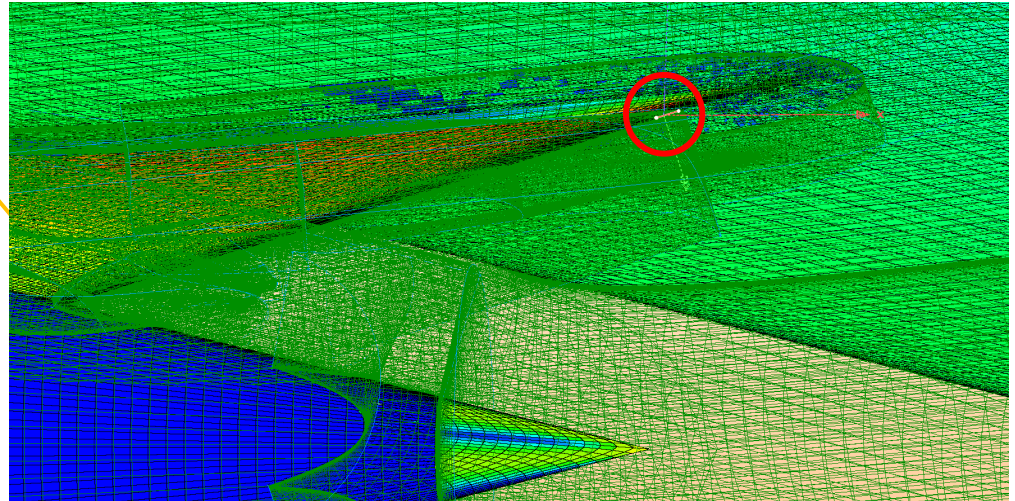
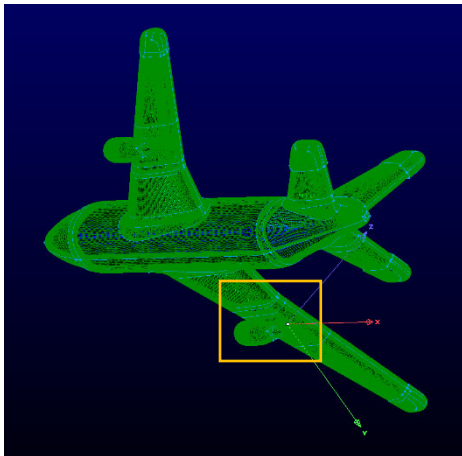

# CASE 3A - BASELINE

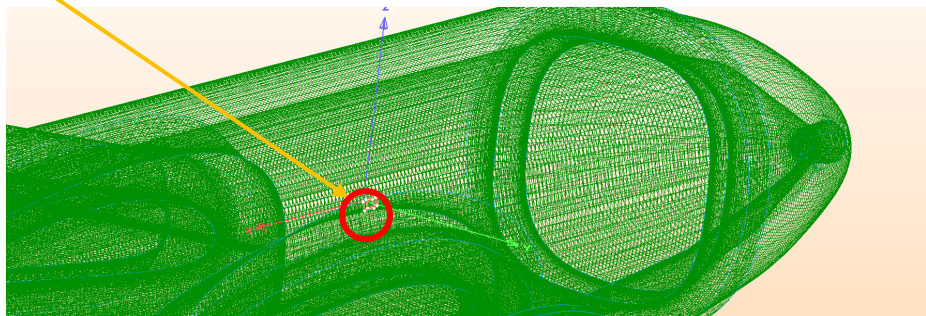
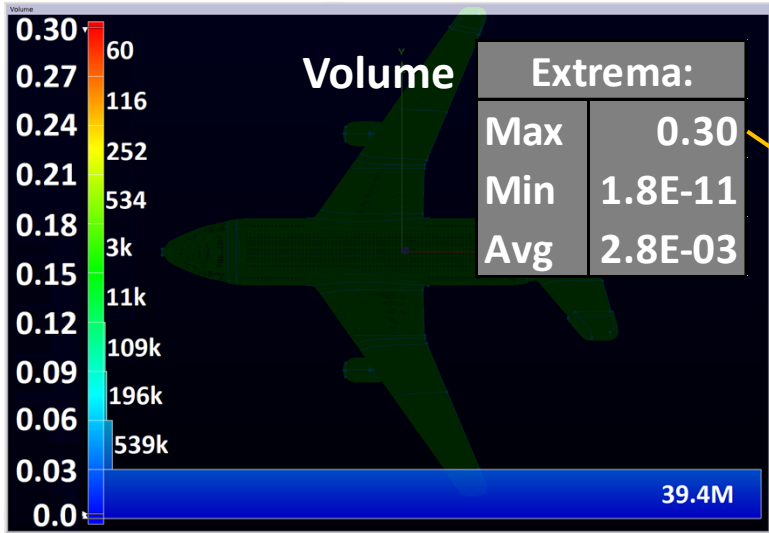
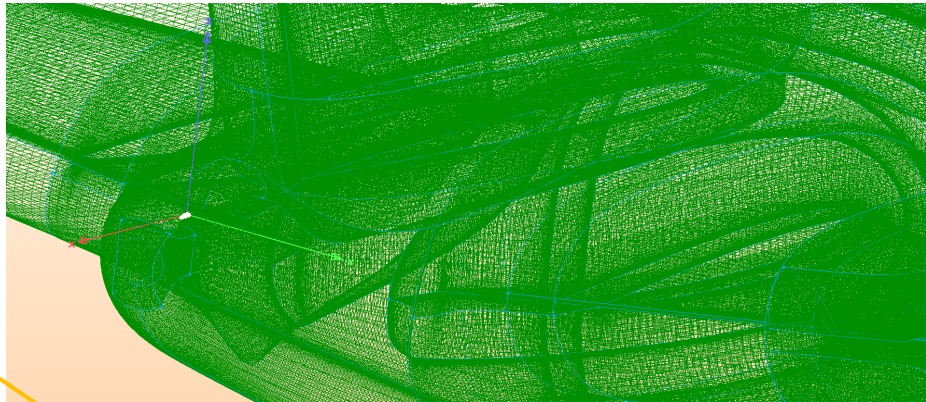
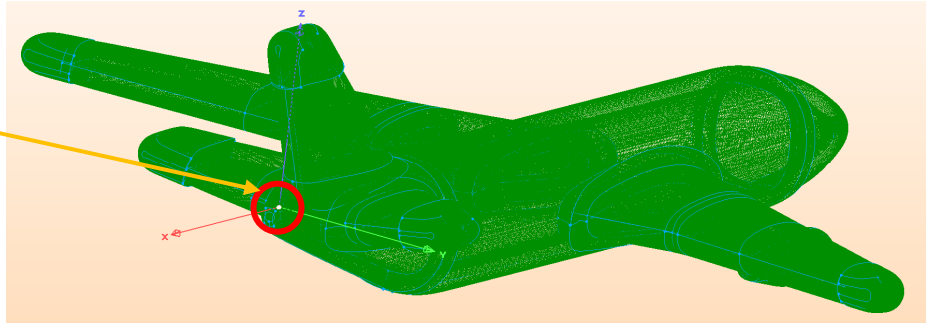
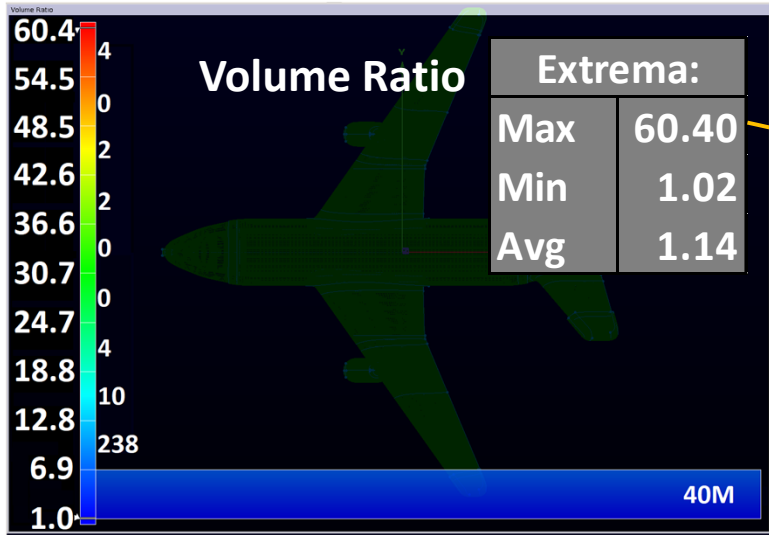

# CASE 3A - BASELINE

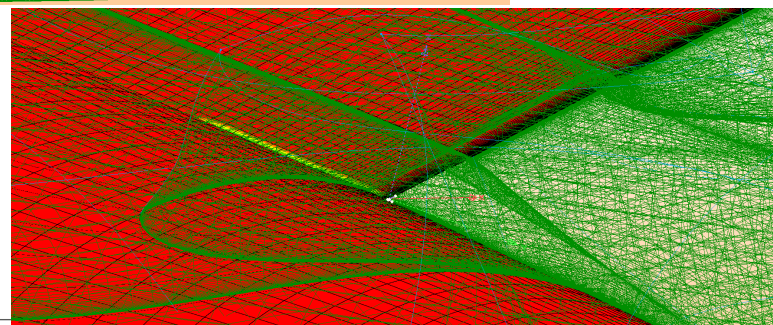
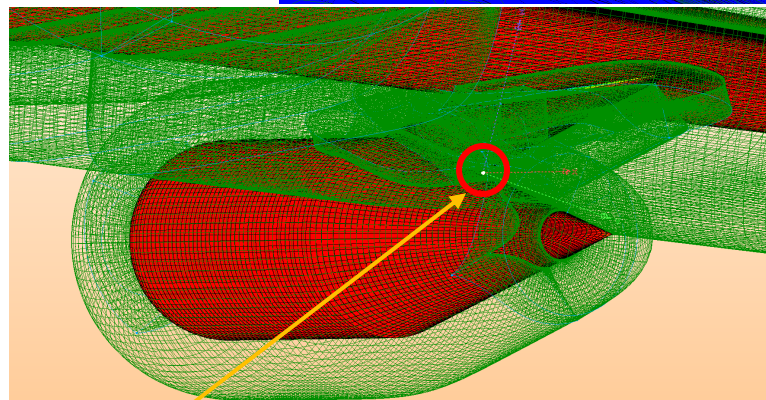
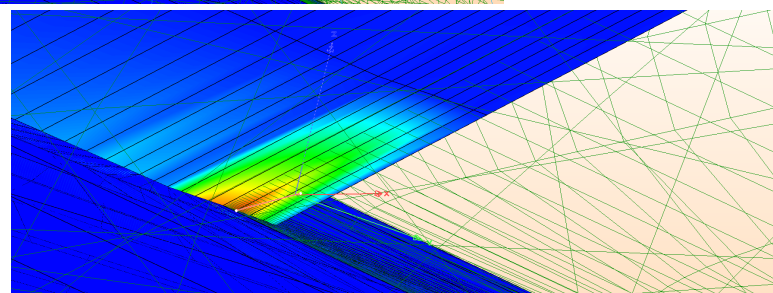
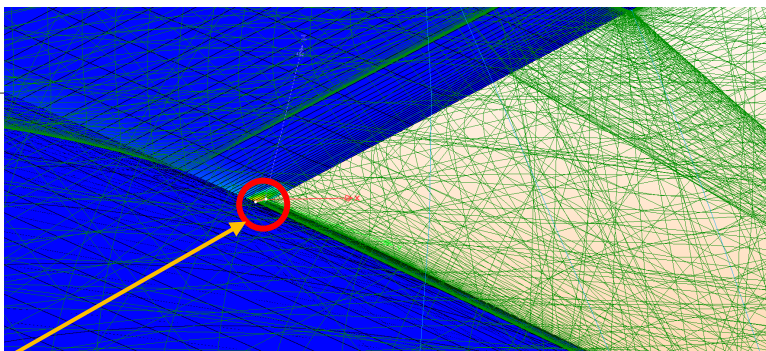
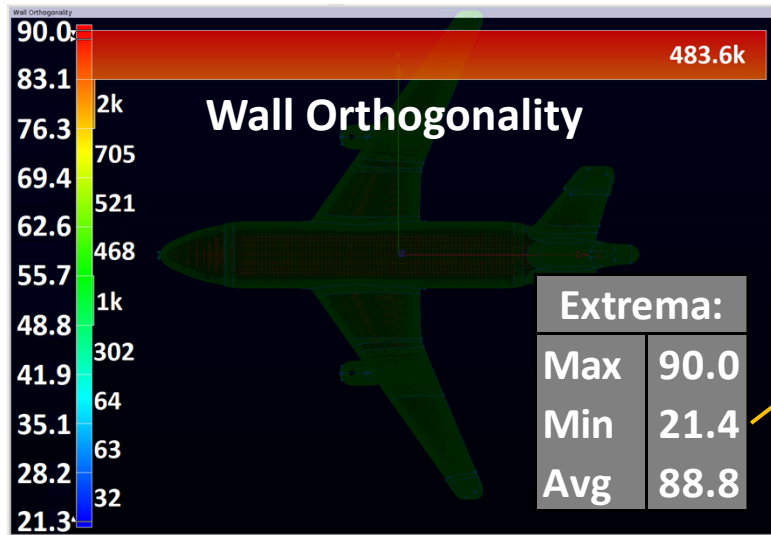
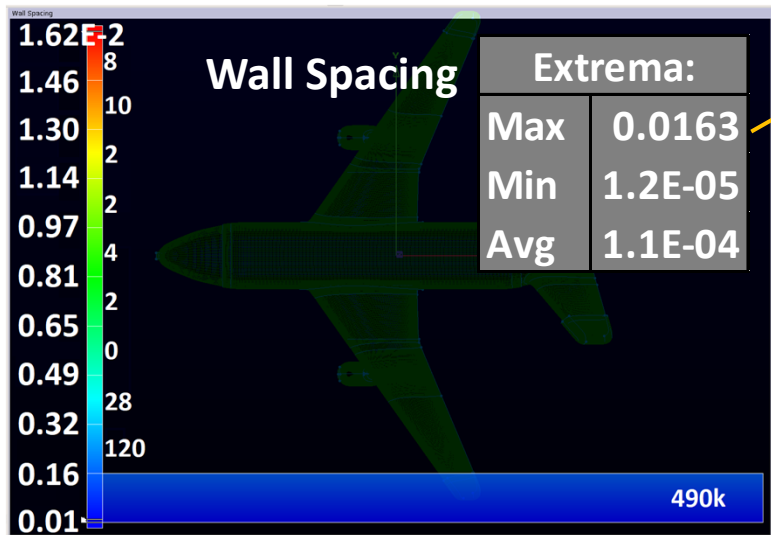

# CASE 3A – VARIATION FROM STEP GEOMETRY FILE

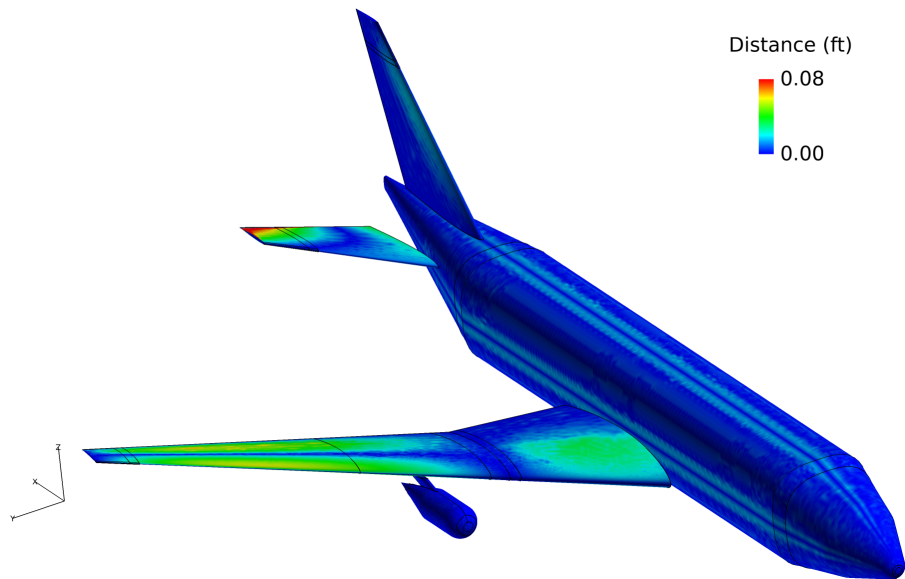

Difference in structured surface grid points from underlying tessellated STL file derived from CAD STEP file using CADFIX

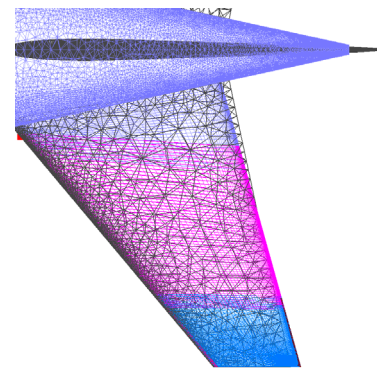

Error in vertical tail due to discrepancy between analytic description and STEP file

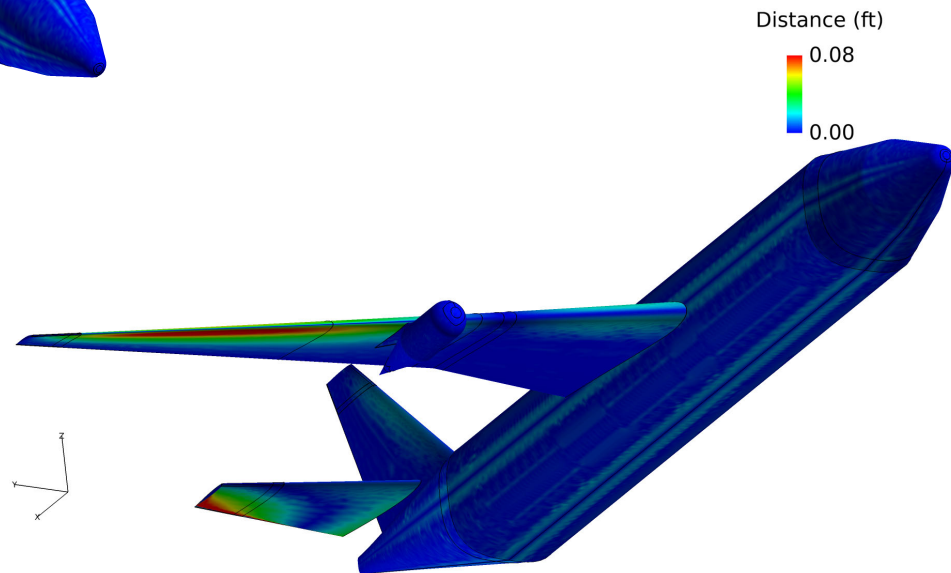

## CASE 3B – WIDE BODY

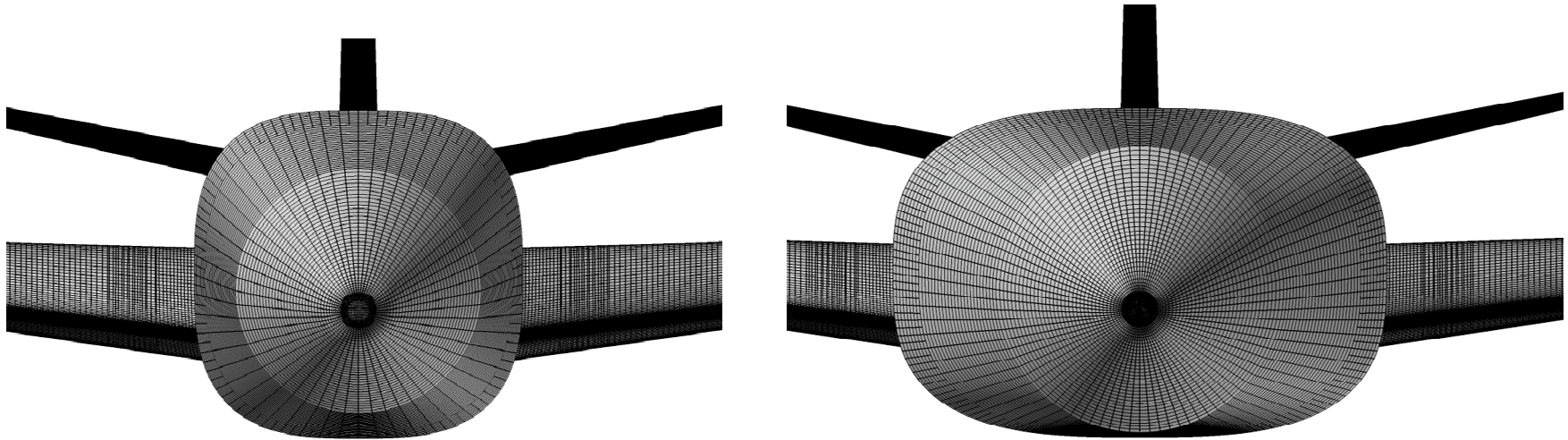

- 52 overset volume grids
  - 279 overlapping surface grids
  - 41.07M cells
- 5 orphans

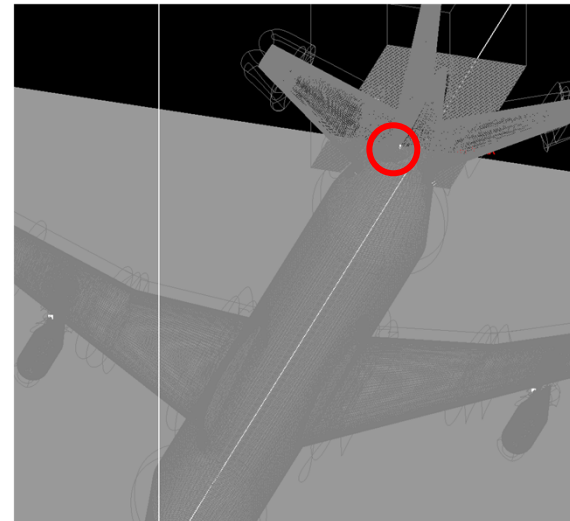

# CASE 3B – WIDE BODY

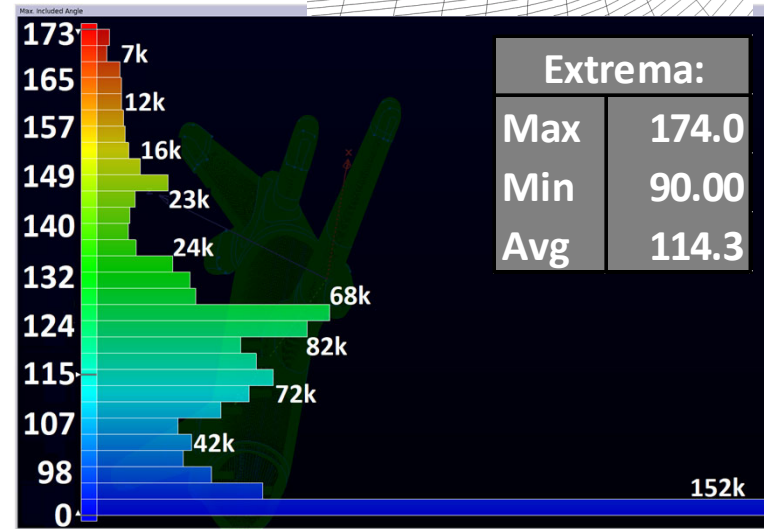
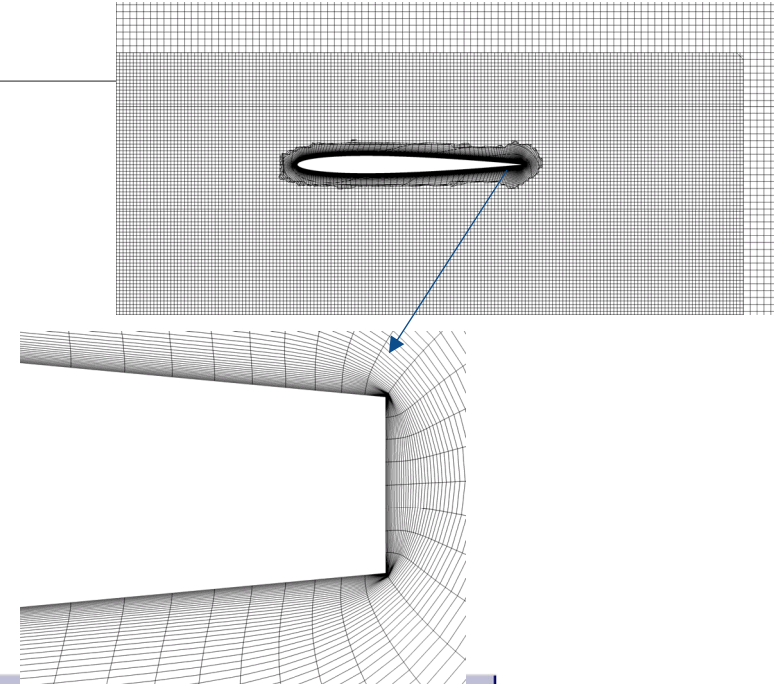
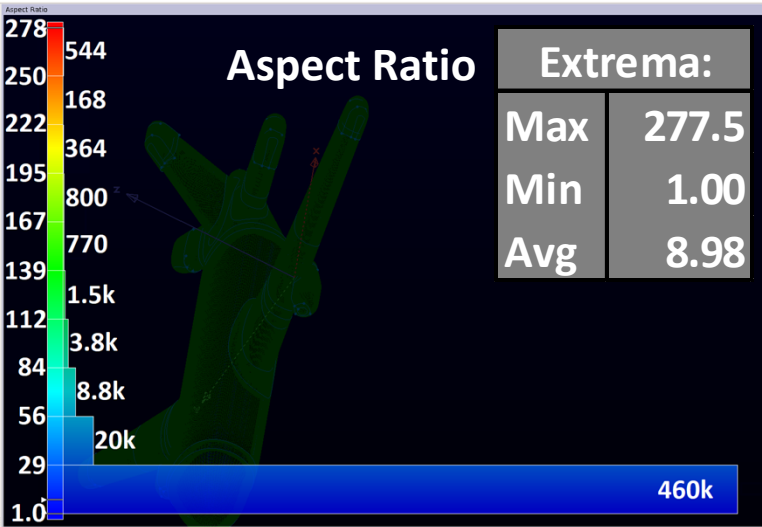

- Maximum Included Angle comes from volume grids generated just below non-negative Jacobians

# CASE 3B – WIDE BODY

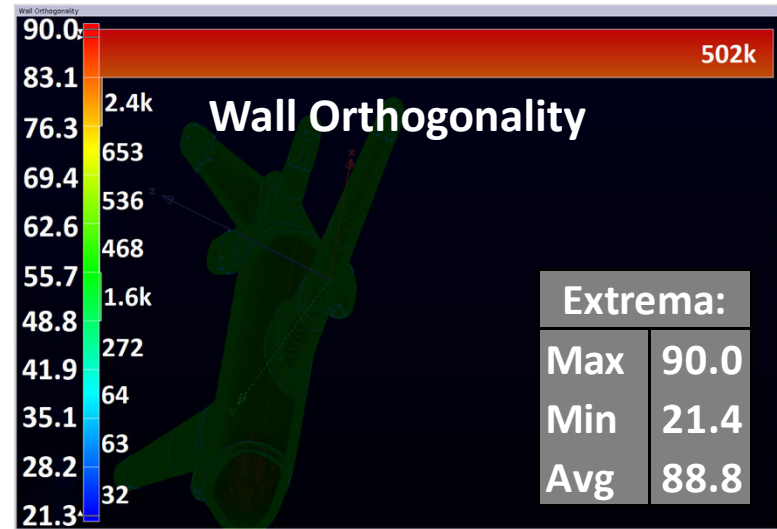
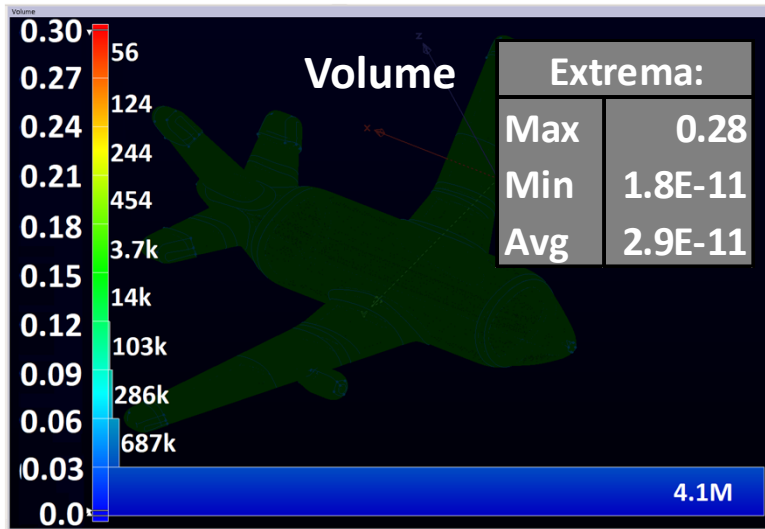
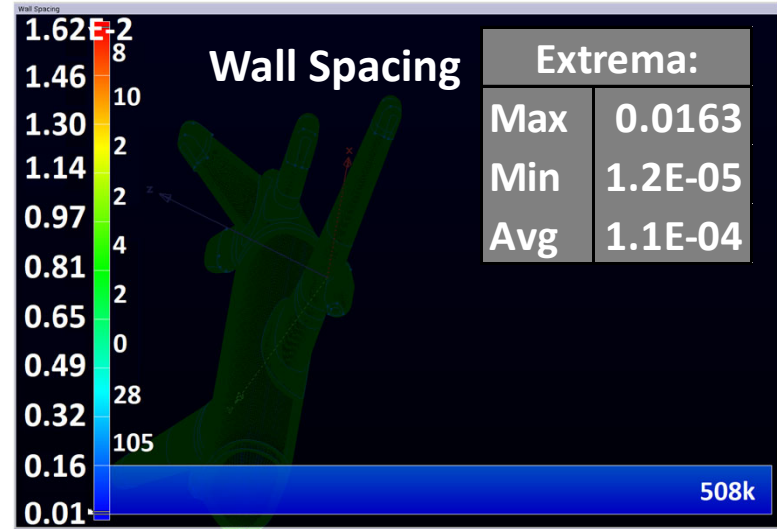
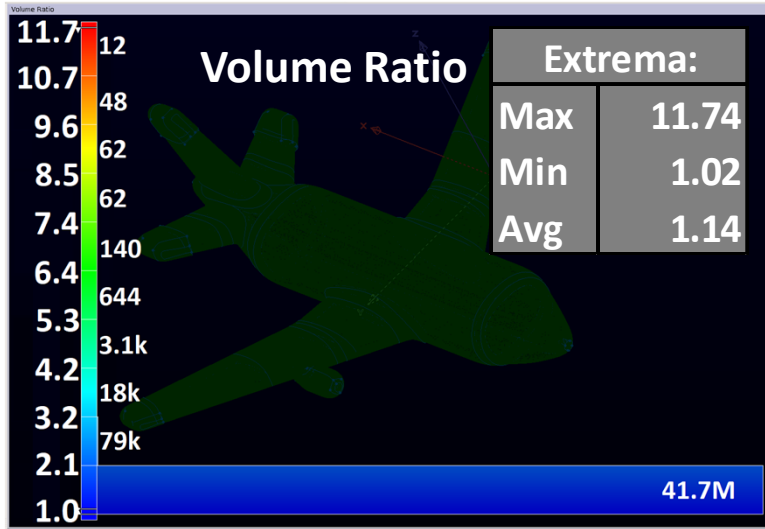

## CASE 3A → 3B PROCESS MODIFICATIONS

- Initially used AUTOCUT within Pegasus but was not consistent between parametric changes, leaving numerous orphans. Went to manual defn. of HCUTS
- Required changes to the number of points around the body to maintain reasonable spacing (points were selected as parameterized quantity rather than spacing criteria)

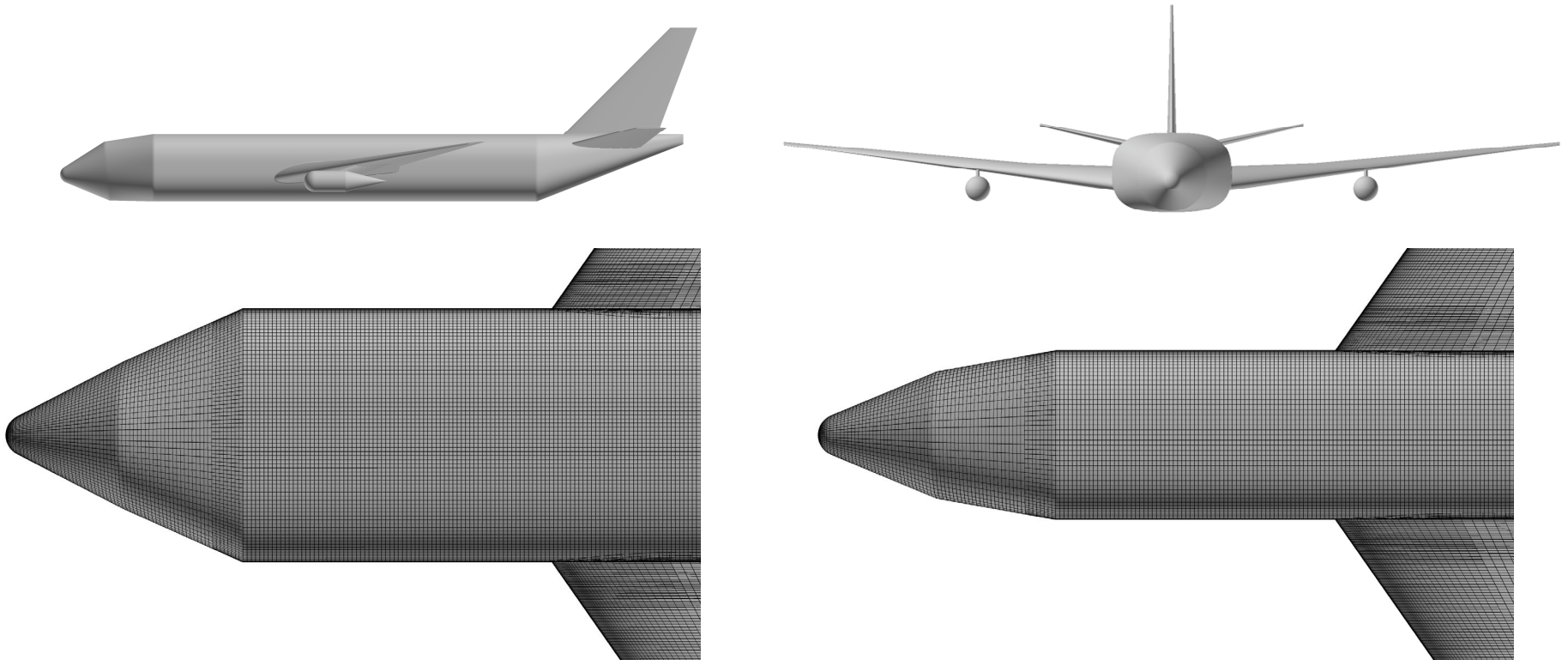

## CASE 3C – INCREASE WING SWEEP

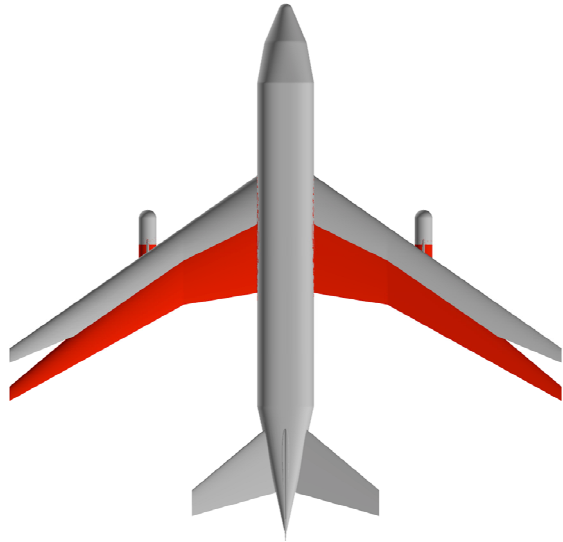

- 52 overset volume grids
  - 279 overlapping surface grids
  - 41.07M cells
- 10 orphans

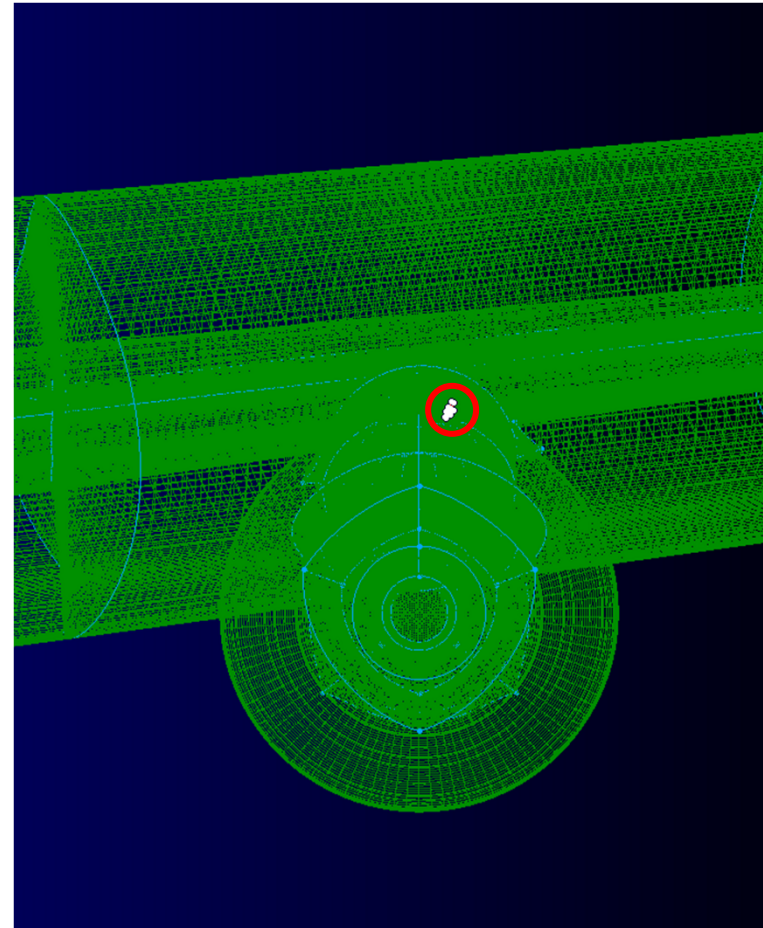

# CASE 3C – INCREASE WING SWEEP

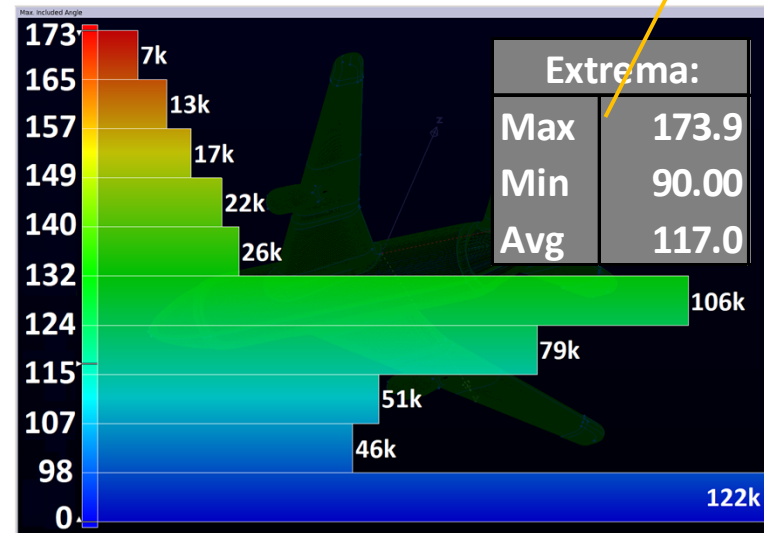
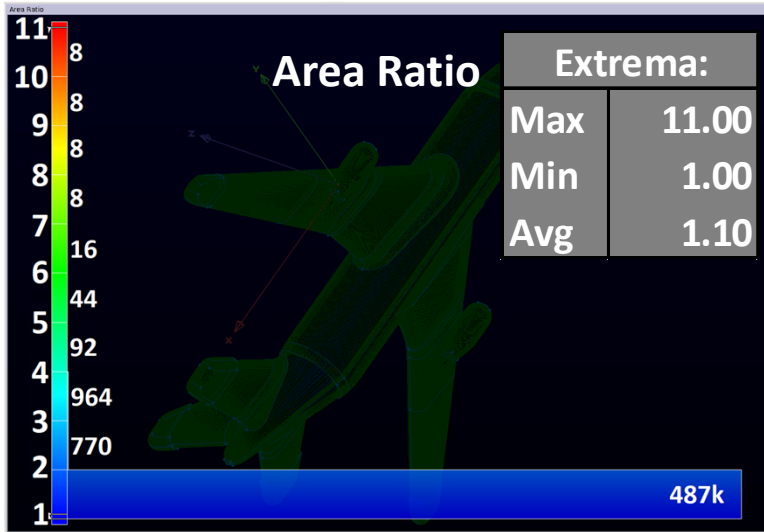
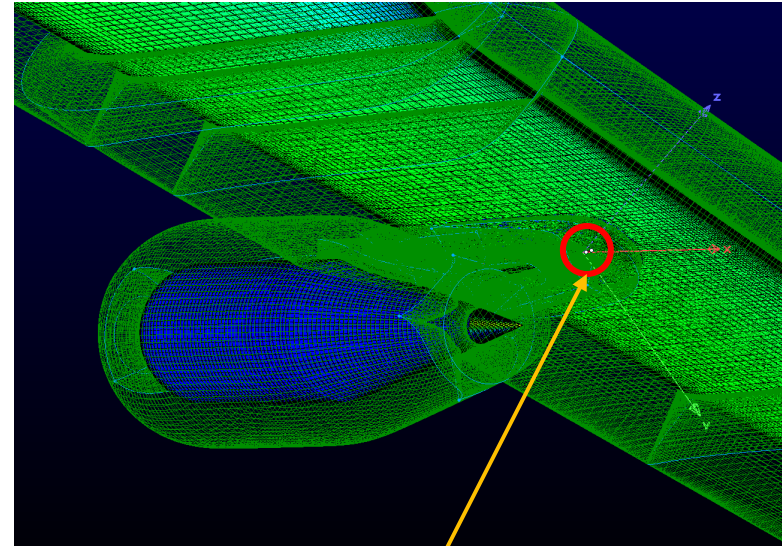

- Maximum Included Angle has similarly high values near corners where volume grids "kink"

# CASE 3C – INCREASE WING SWEEP

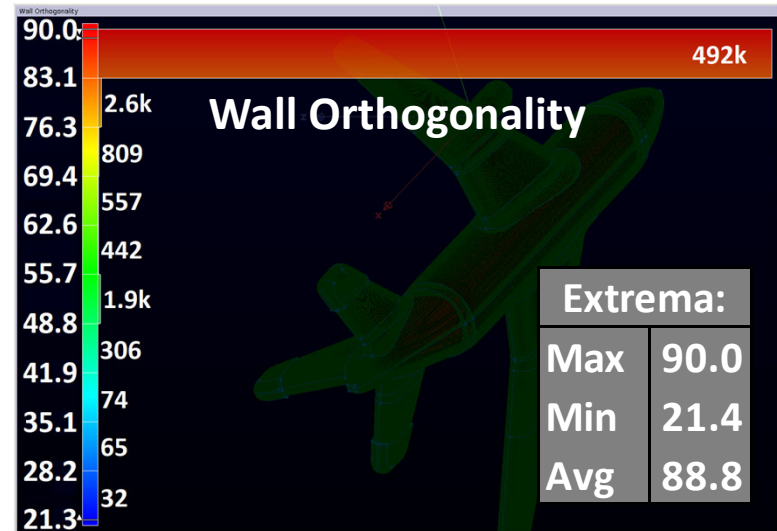
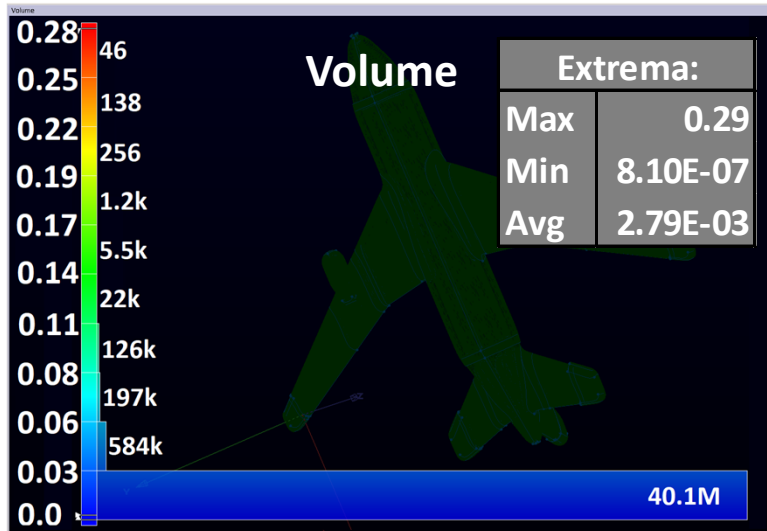
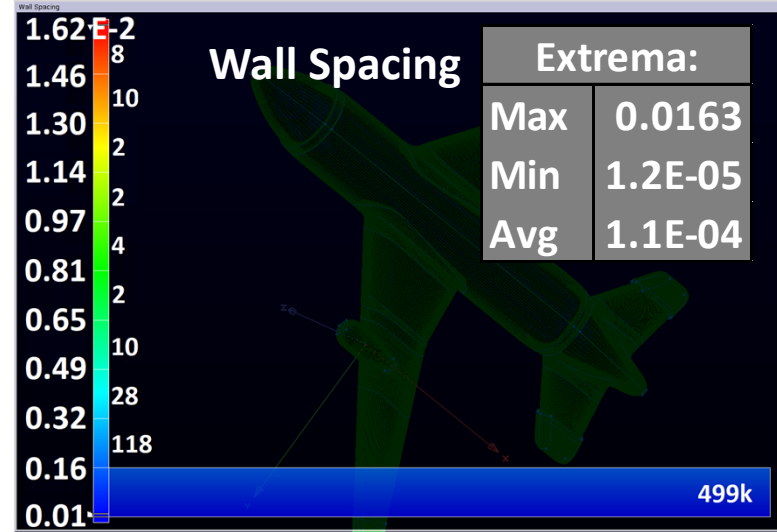
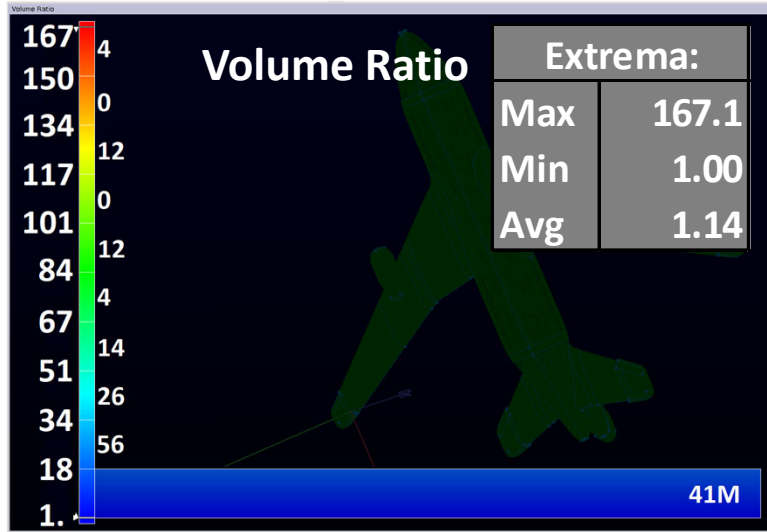

## CASE 3A → 3C PROCESS MODIFICATIONS

- Input parameters changes to account for new wing sweep
- Adjusted smoothing and splay in volume grid for wing collar

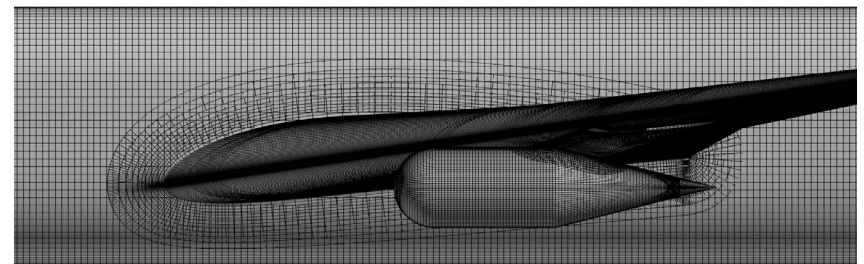
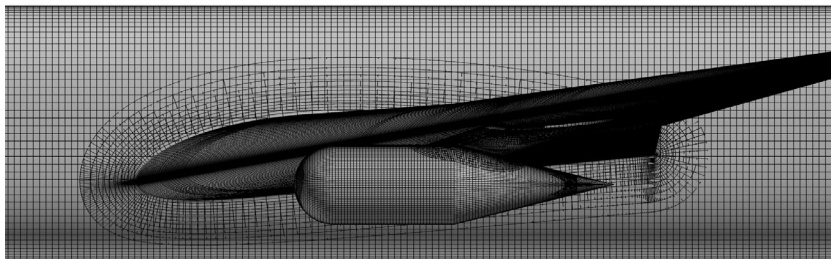
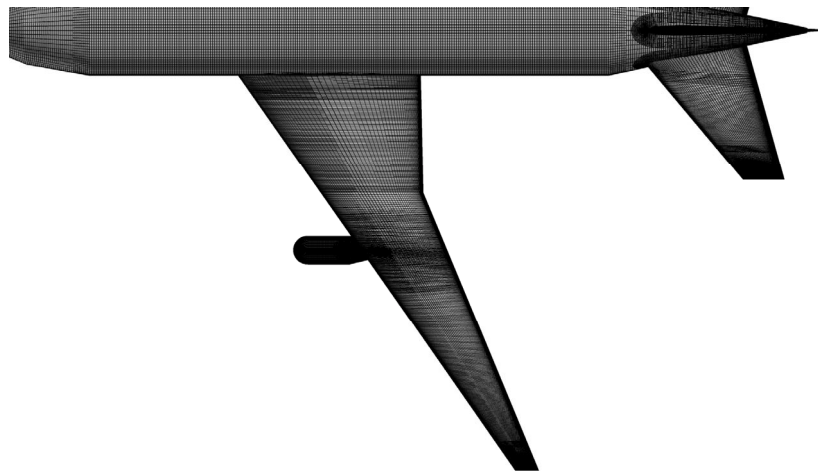
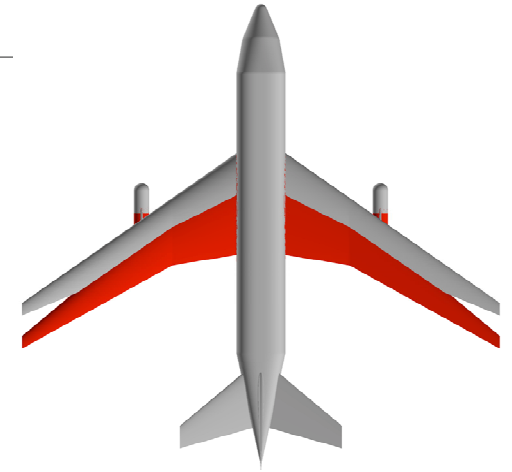

## CASE 3D – RELOCATE PYLON/POD

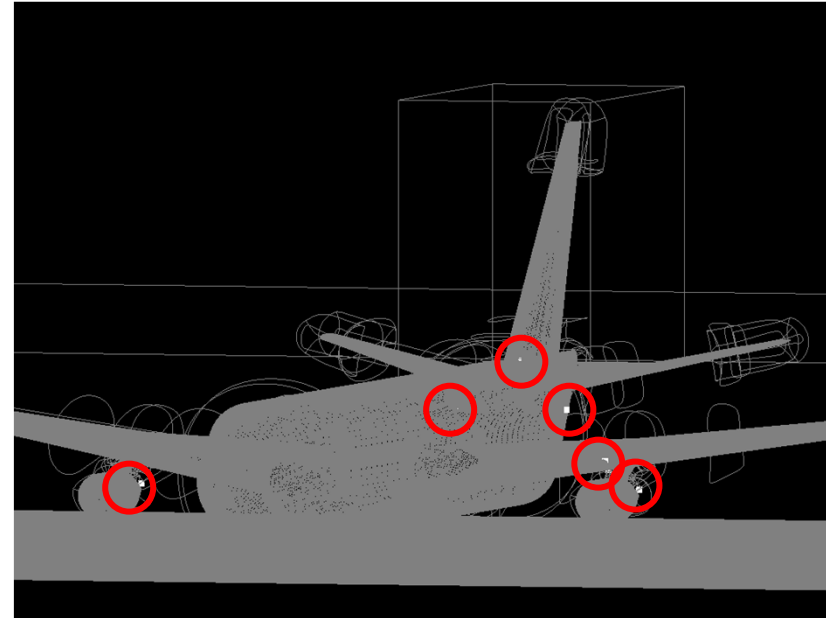
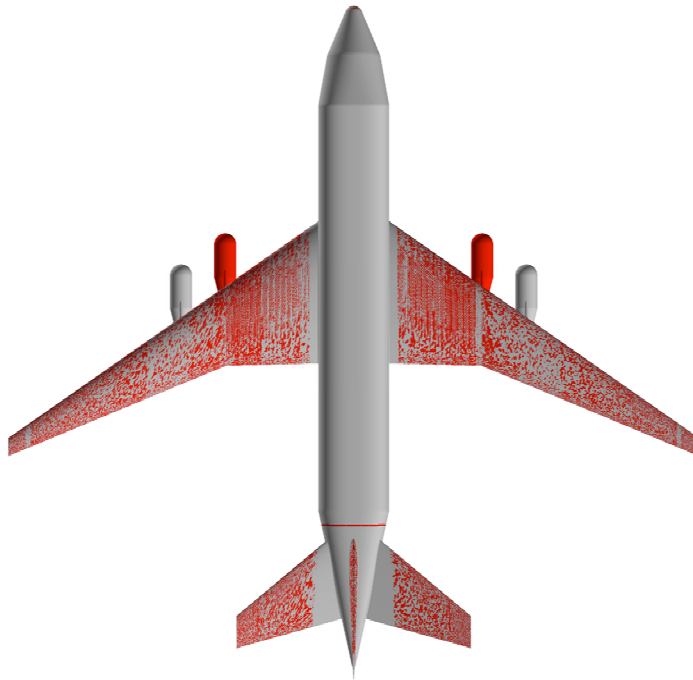

- 52 overset volume grids
  - 279 overlapping surface grids
  - 40.4M cells
- 12 orphans

# CASE 3D – RELOCATE PYLON/POD

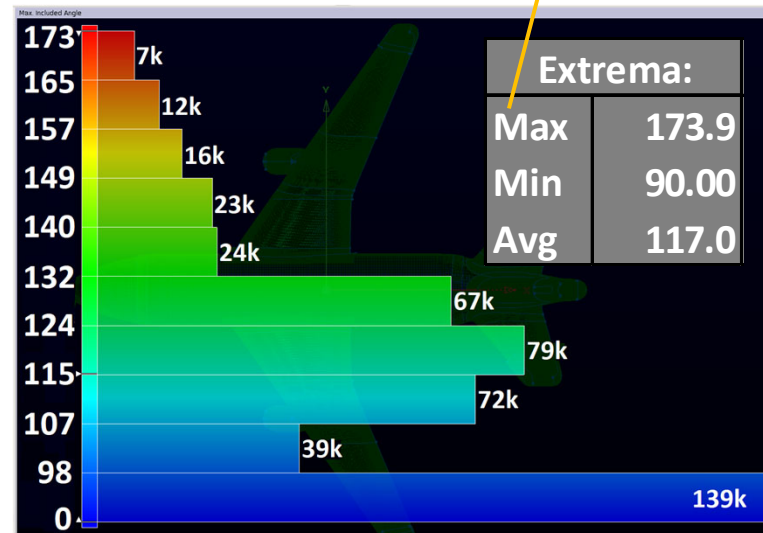
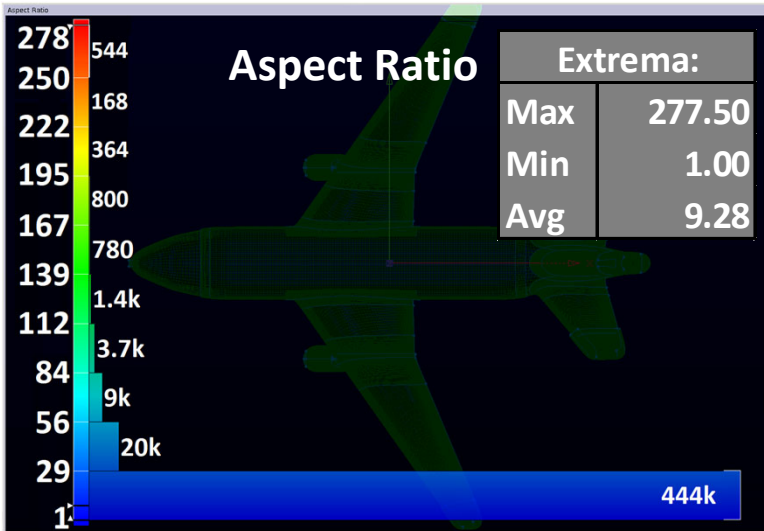
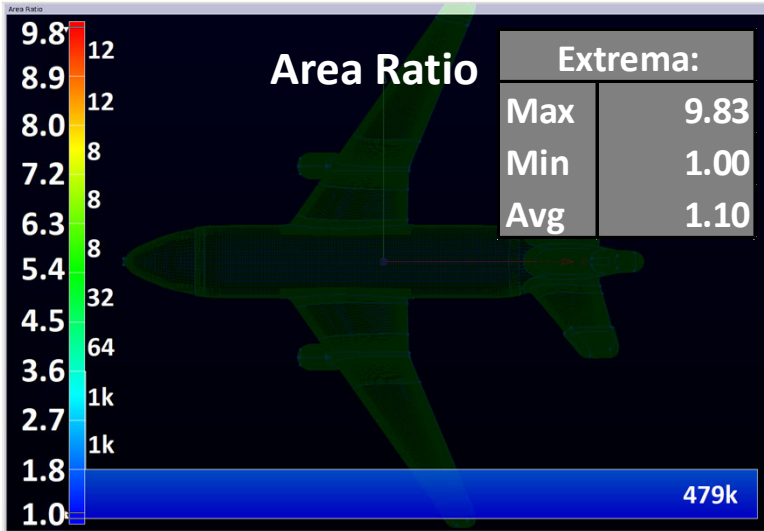
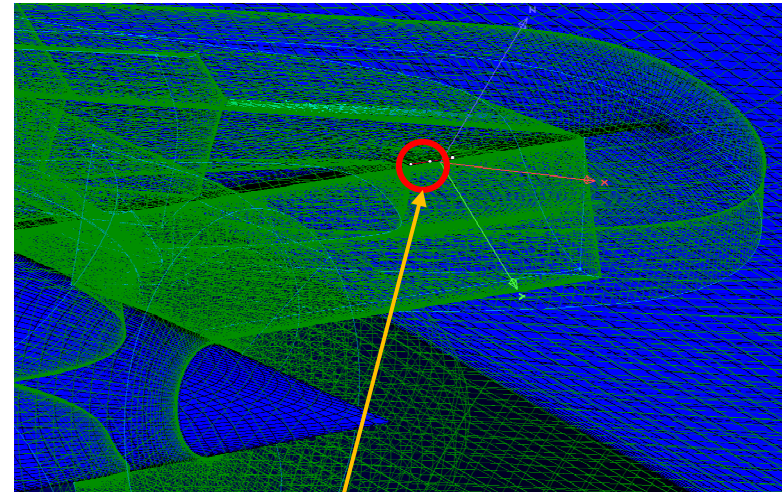

- Similar high Maximum Included Angle around corners

# CASE 3D – RELOCATE PYLON/POD

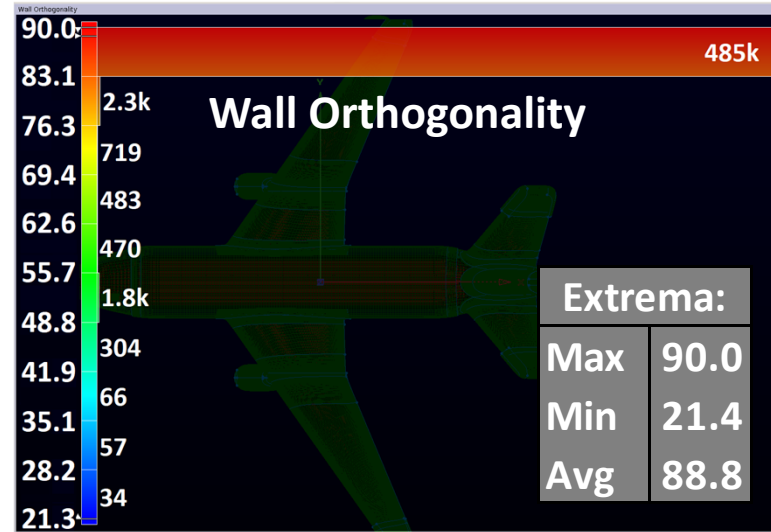
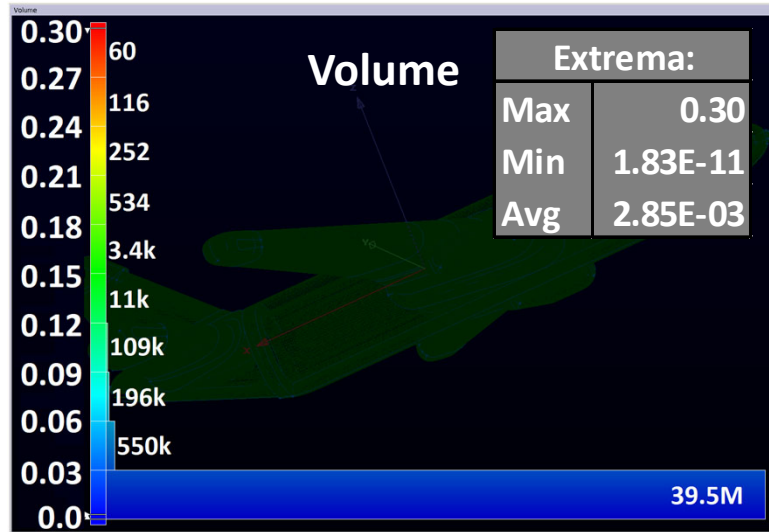
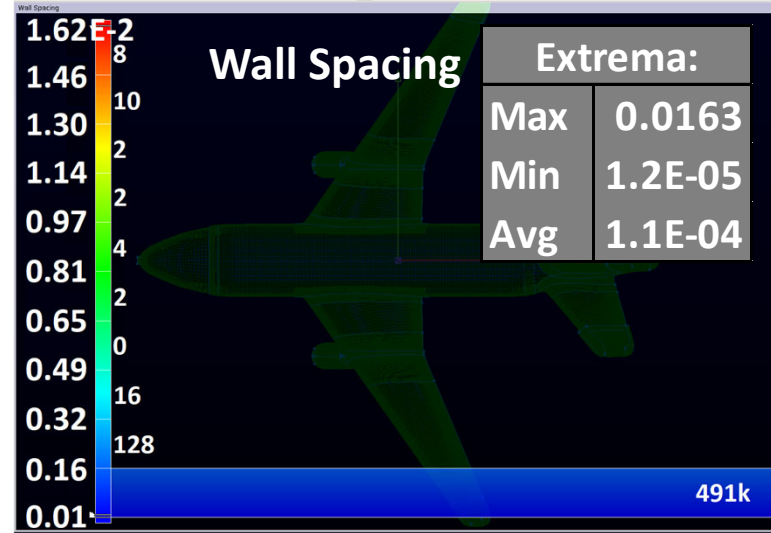
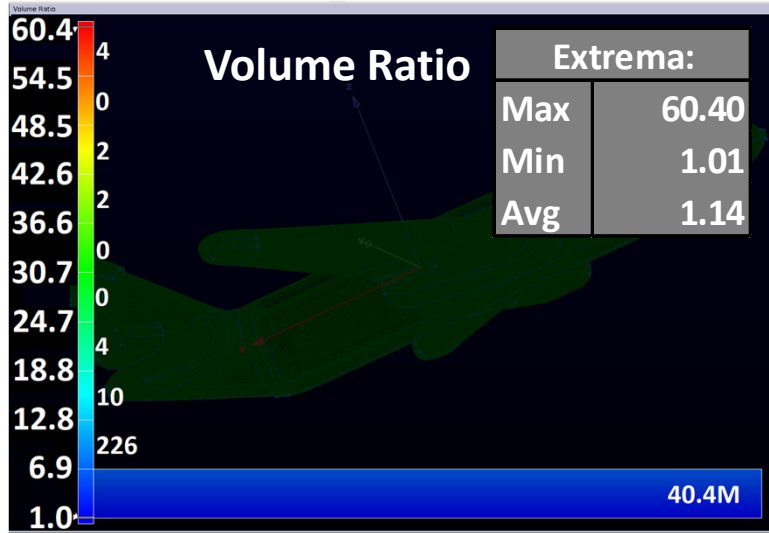

## CASE 3A → 3D PROCESS MODIFICATIONS

- Did NOT require changes to the system of scripts, just to the pylon/pod location parameter

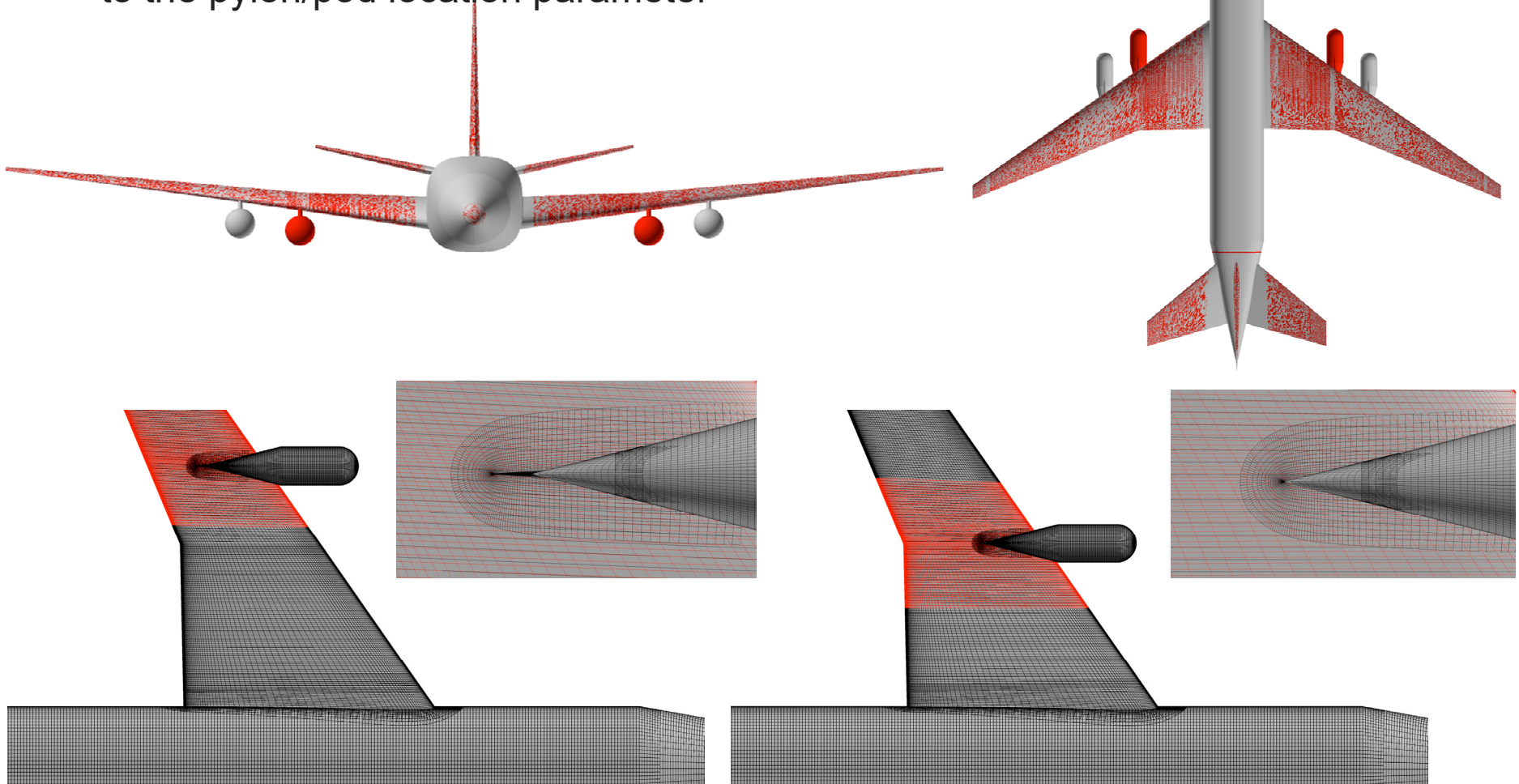

## CASE 3E - NARROW POD/SHORT PYLON

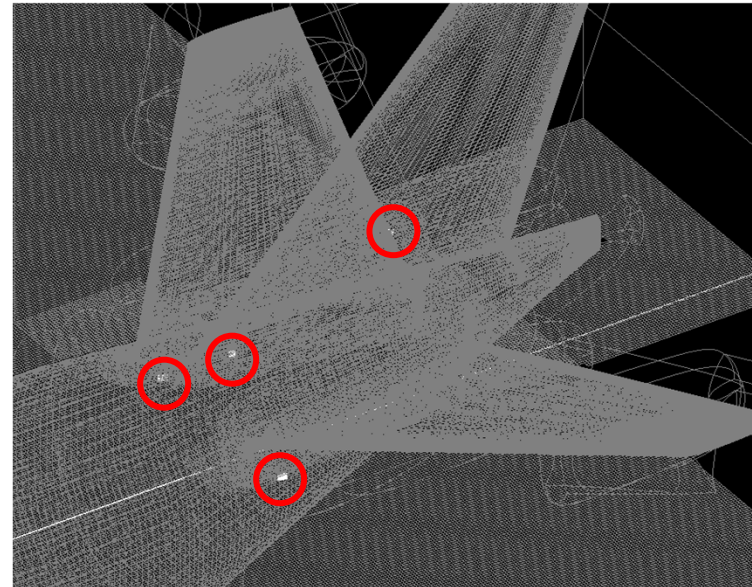
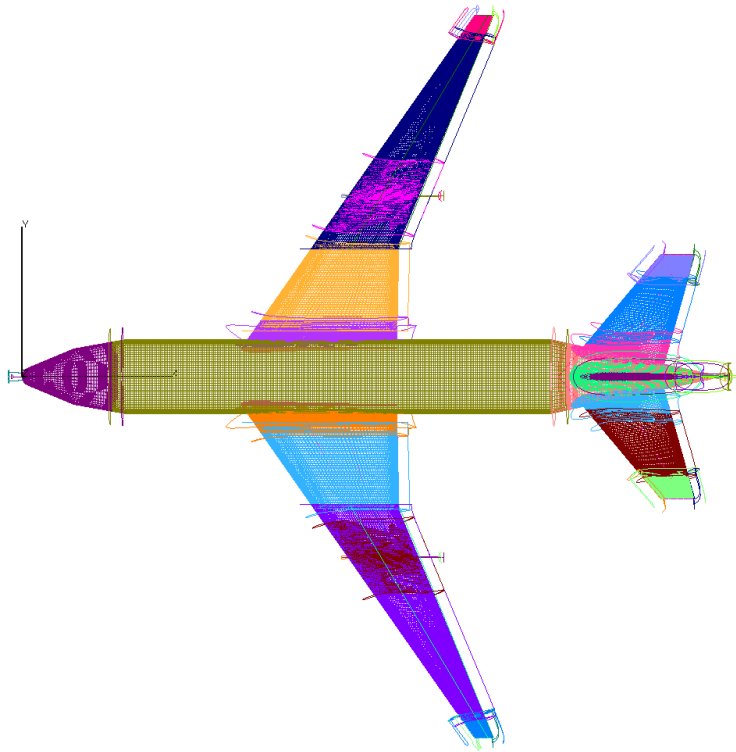

- 50 overset volume grids
  - 269 overlapping surface grids
  - 557,840 quads
  - 47.1M cells
- 8 orphans

# CASE 3E - NARROW POD/SHORT PYLON

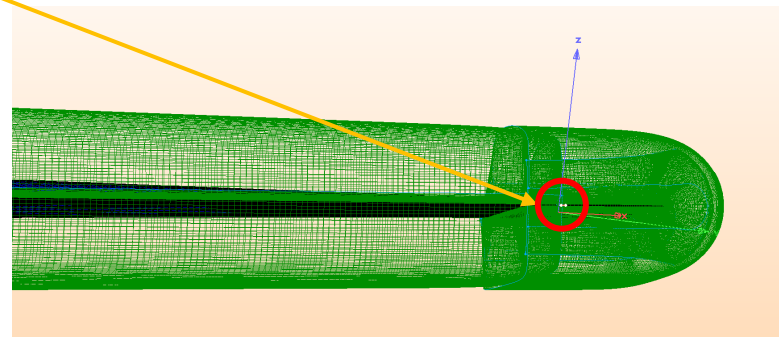
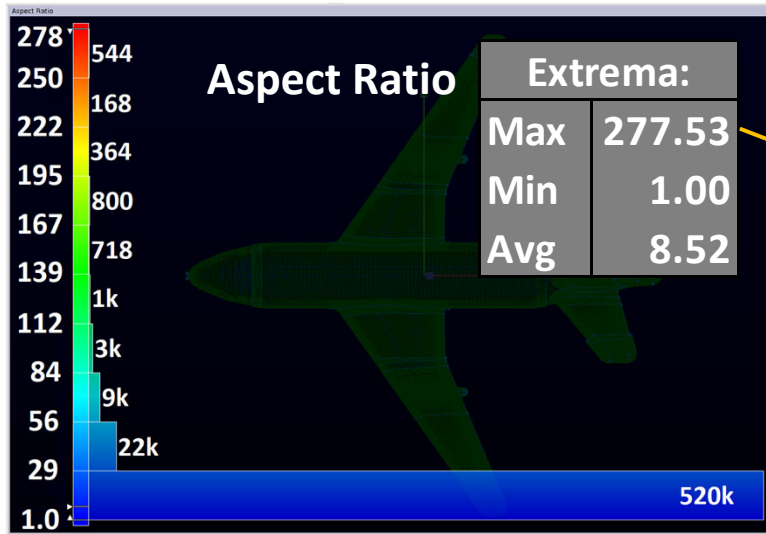
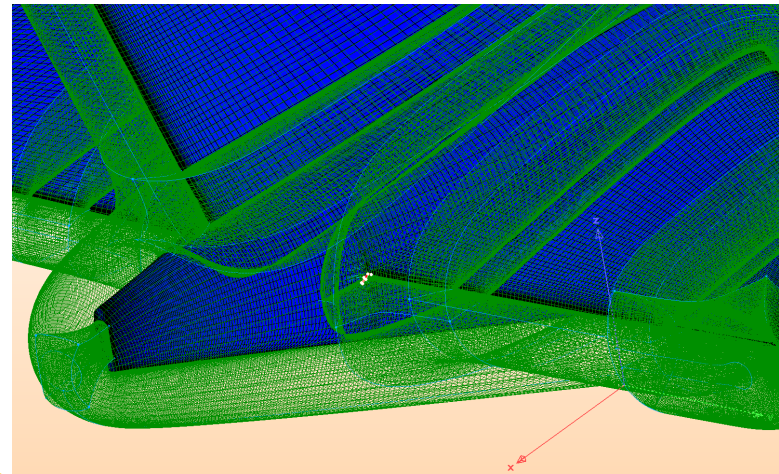
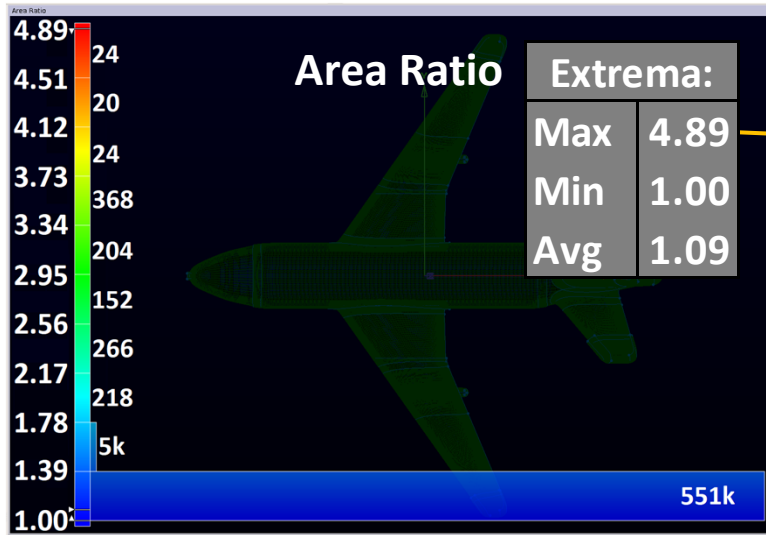
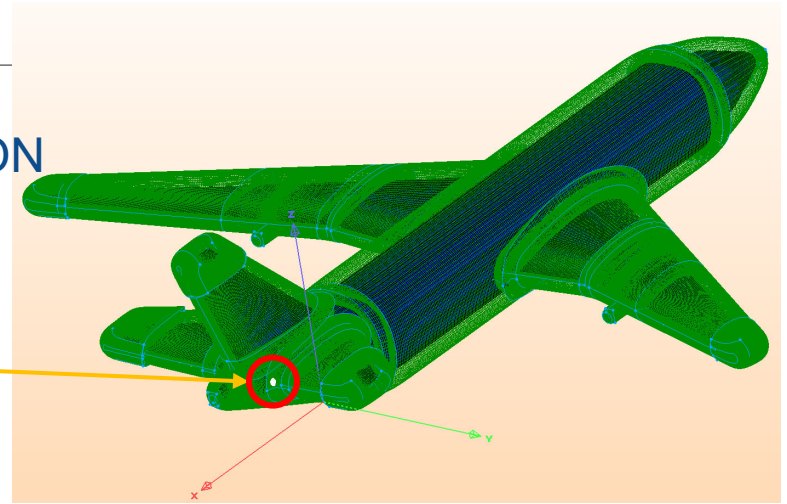

# CASE 3E - NARROW POD/SHORT PYLON

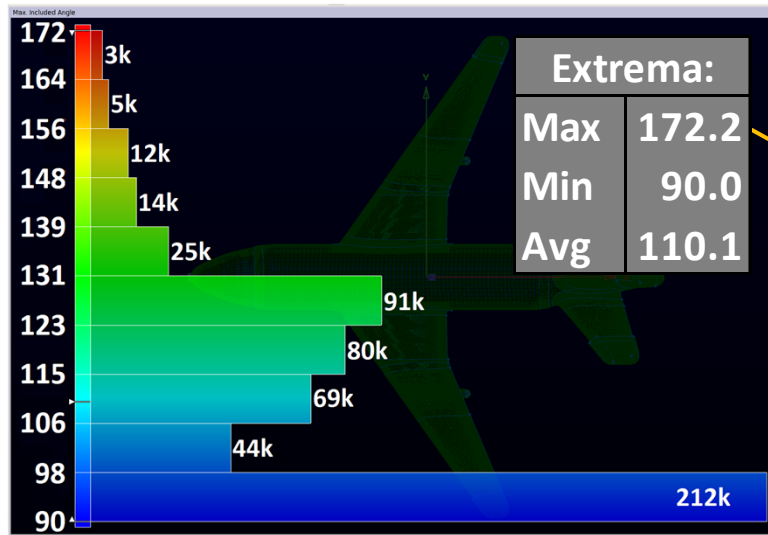

Max Included Angle

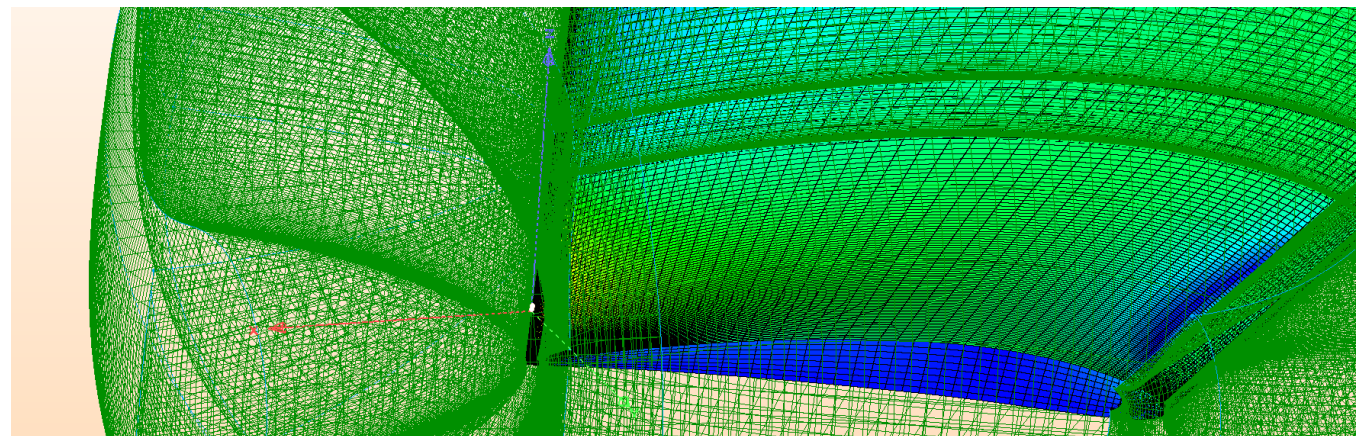
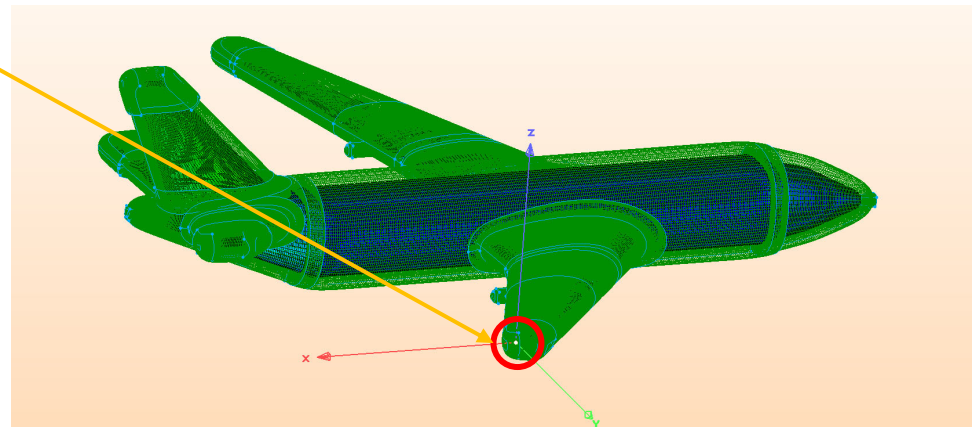

# CASE 3E - NARROW POD/SHORT PYLON

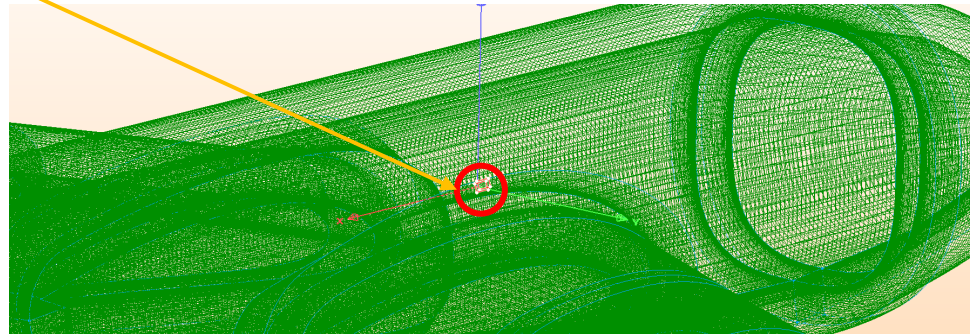
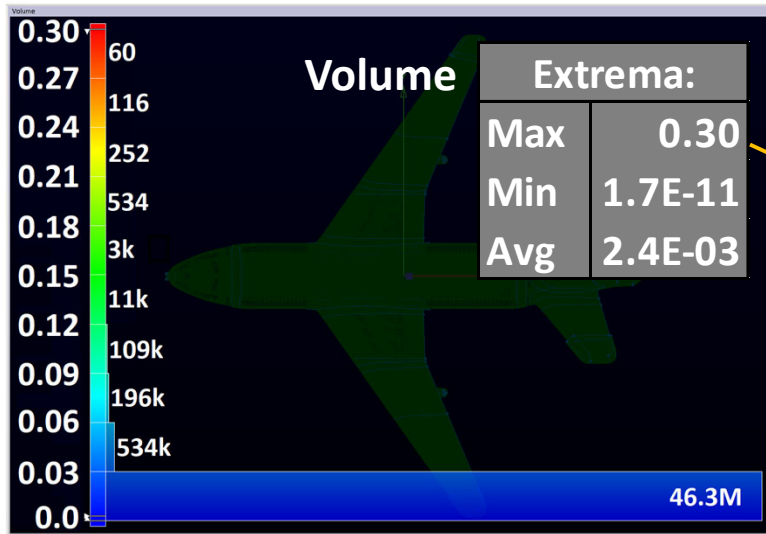
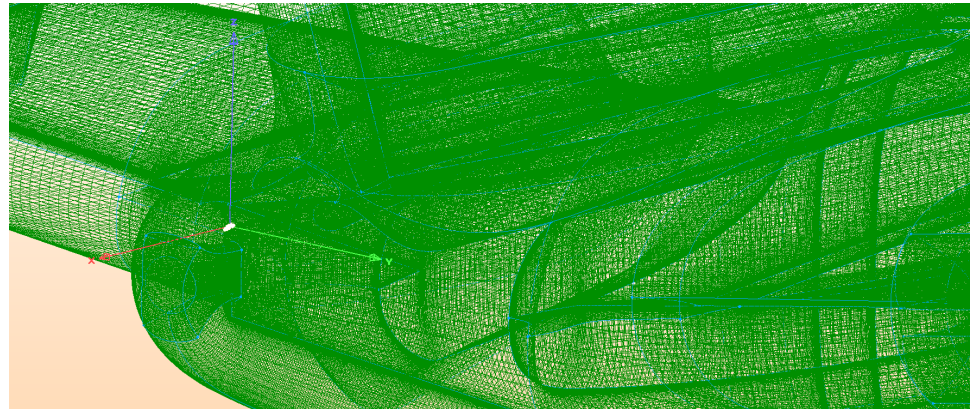
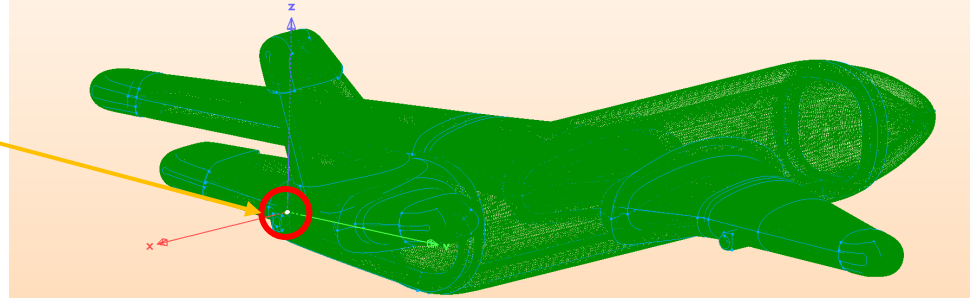
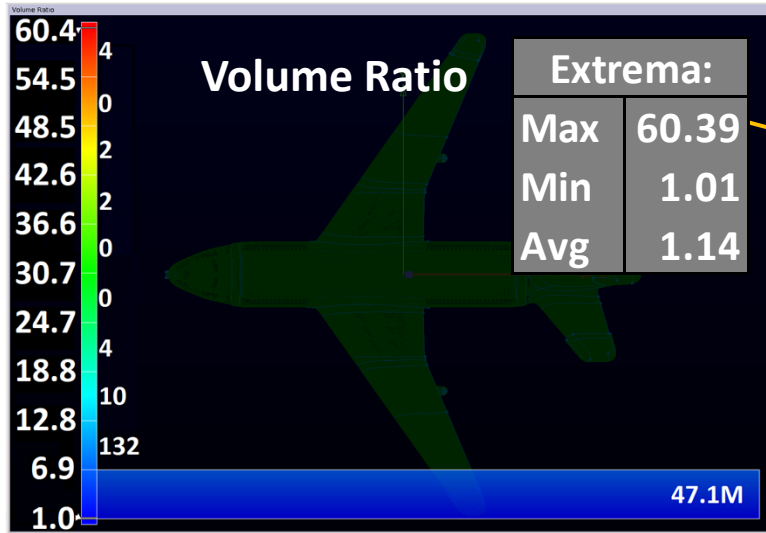

# CASE 3E - NARROW POD/SHORT PYLON

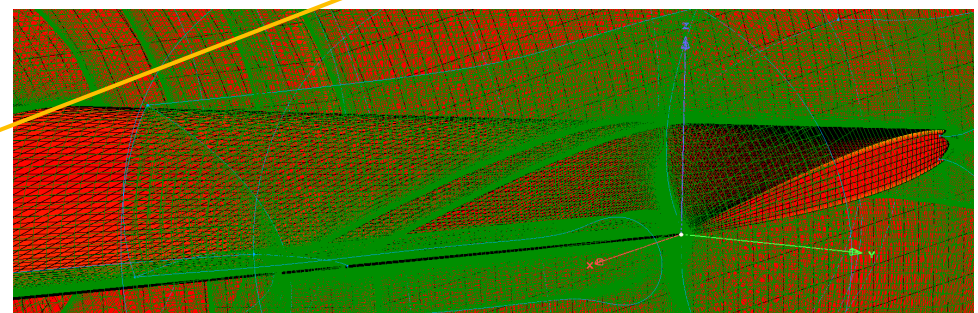
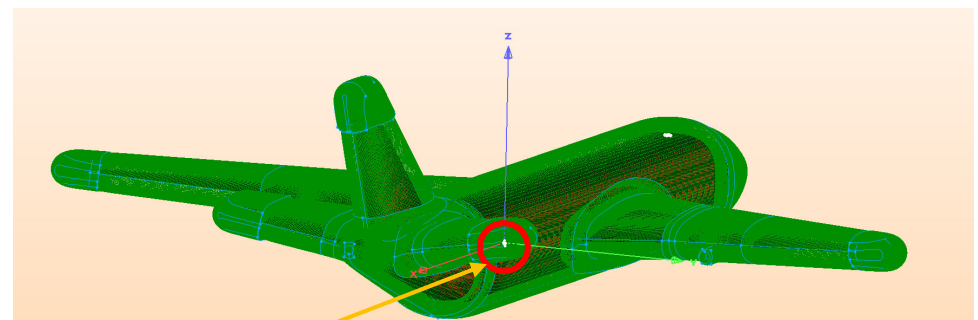
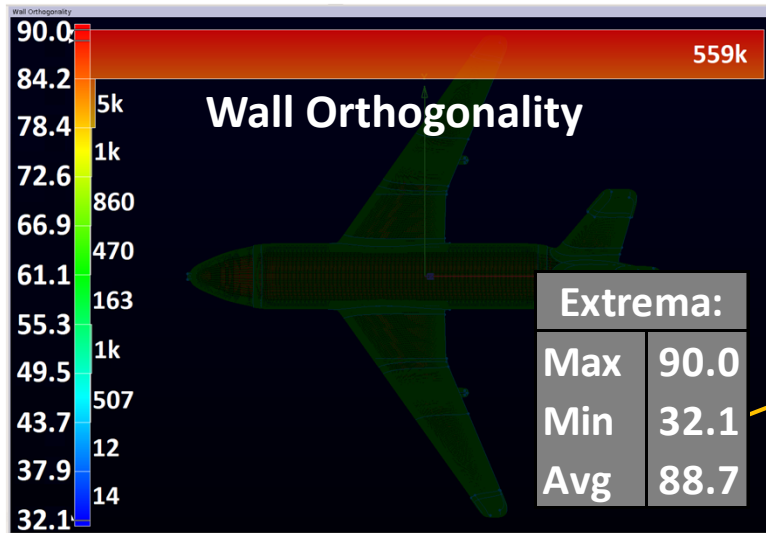
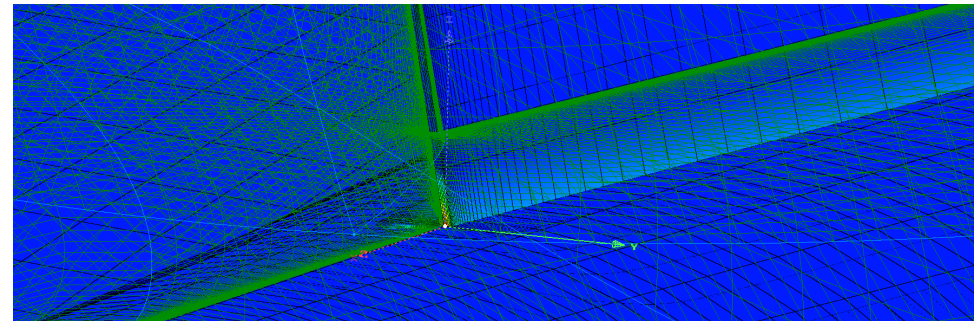
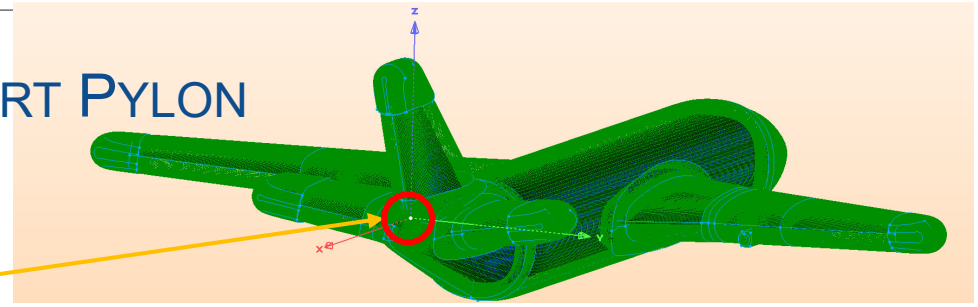
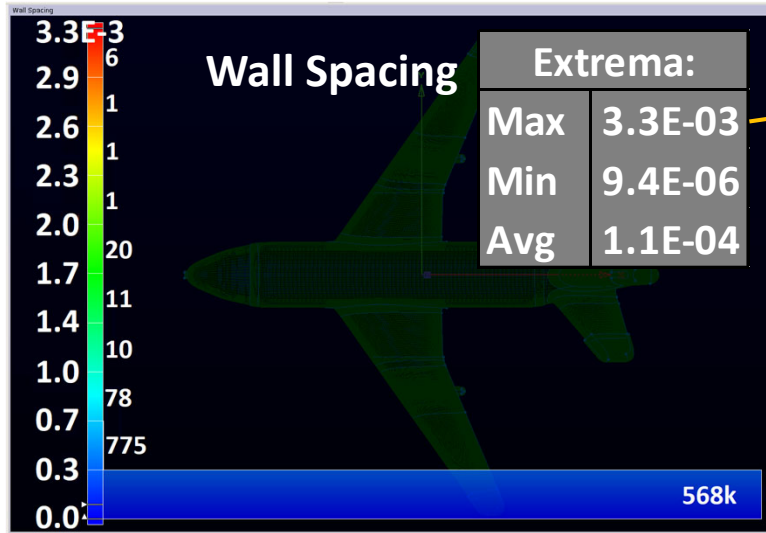

## CASE 3E - NARROW POD/SHORT PYLON

- Required an entire overhaul of pod mesh generation due to large change in geometry
- Other grids were generated using existing scripts

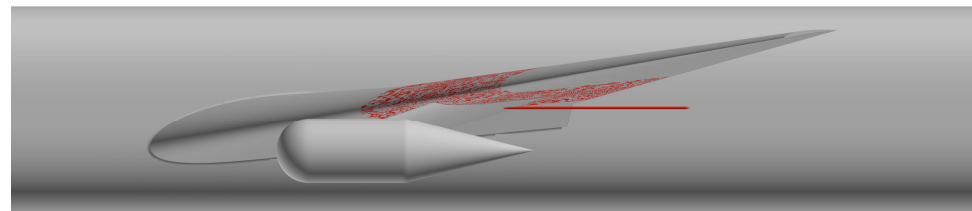
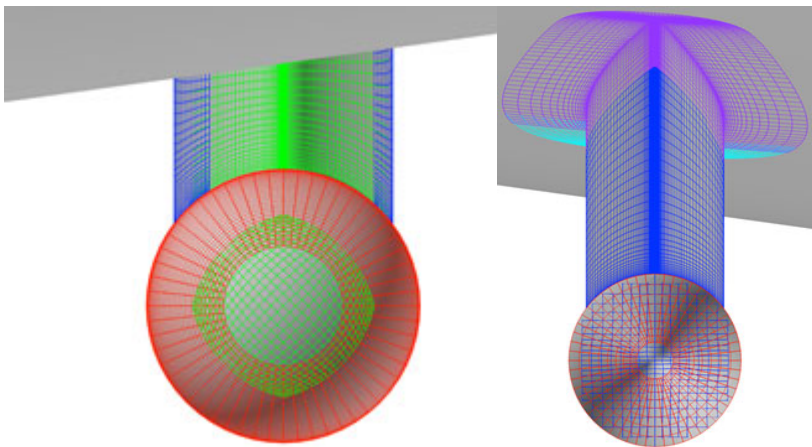
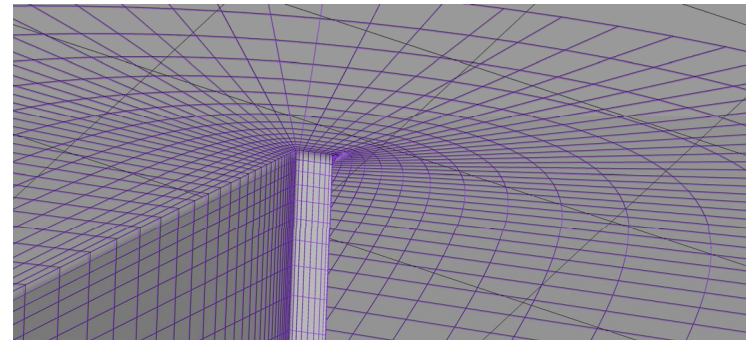
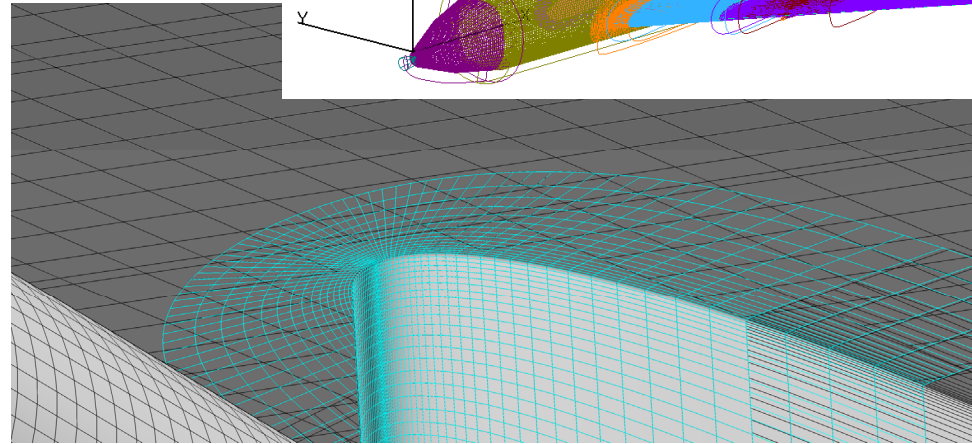
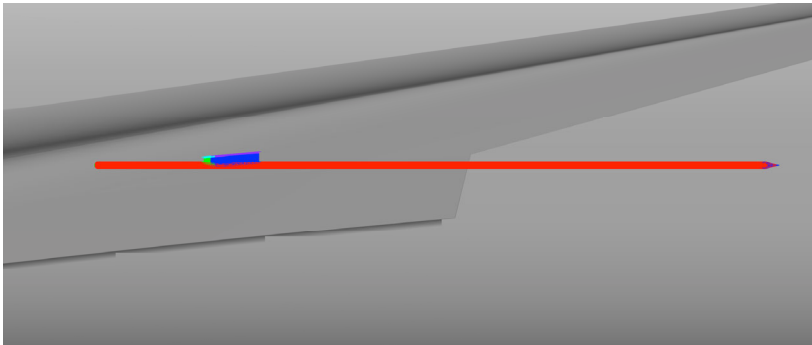
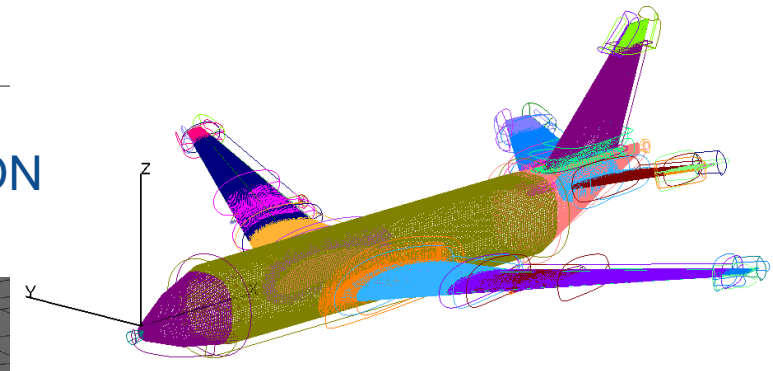

# GRIDDING ISSUES AND CHALLENGES

## ISSUES

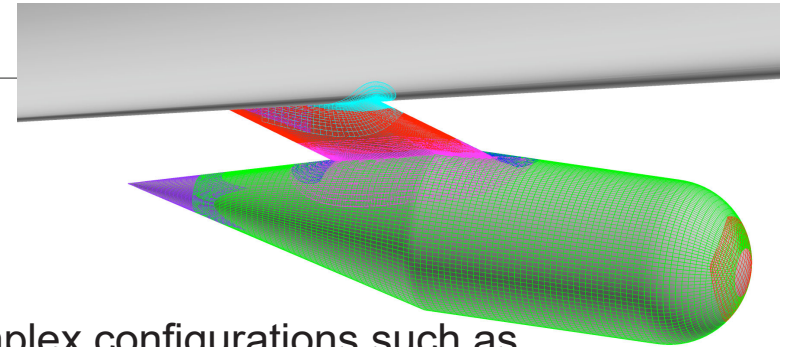

- Collar grids very difficult to generate around complex configurations such as pylon/wing/pod interaction regions
- Required considerable user interaction to get grid parameters set such that valid grid volumes generated
- Grid parameters very sensitive to grid resolution/geometry modifications (requires modifications of scripts)
- For particularly complex configurations, collar grids may have to be broken up in circumferential direction in order to relax constraints on volume grids

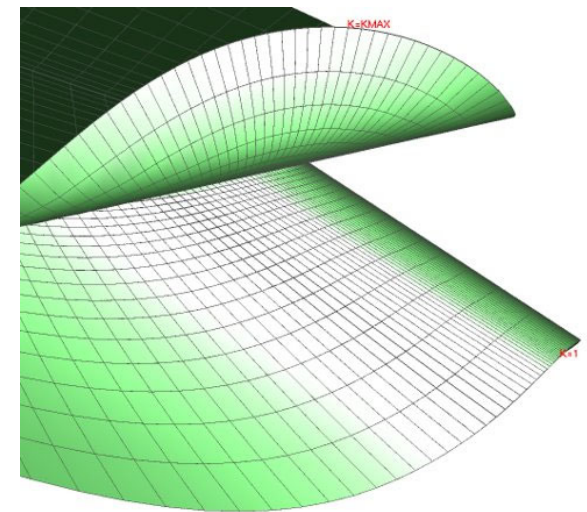
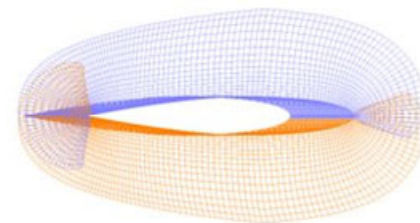
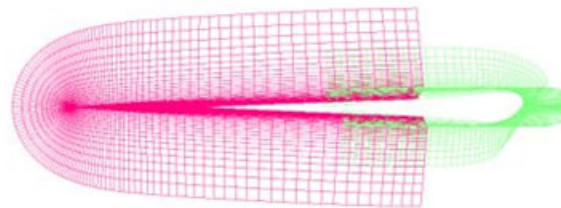
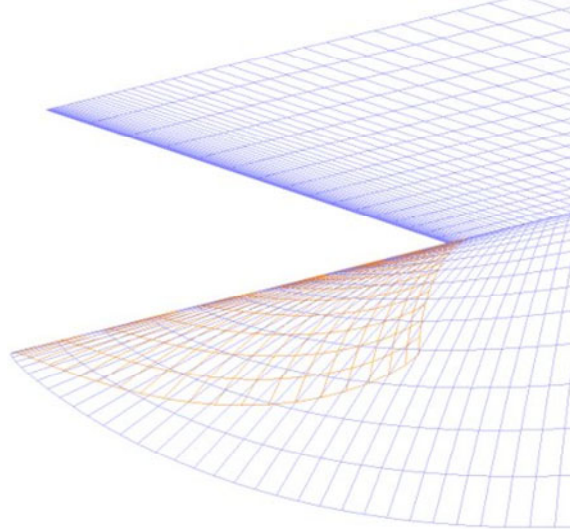

# ISSUES

Spacing on Body Super Ellipse

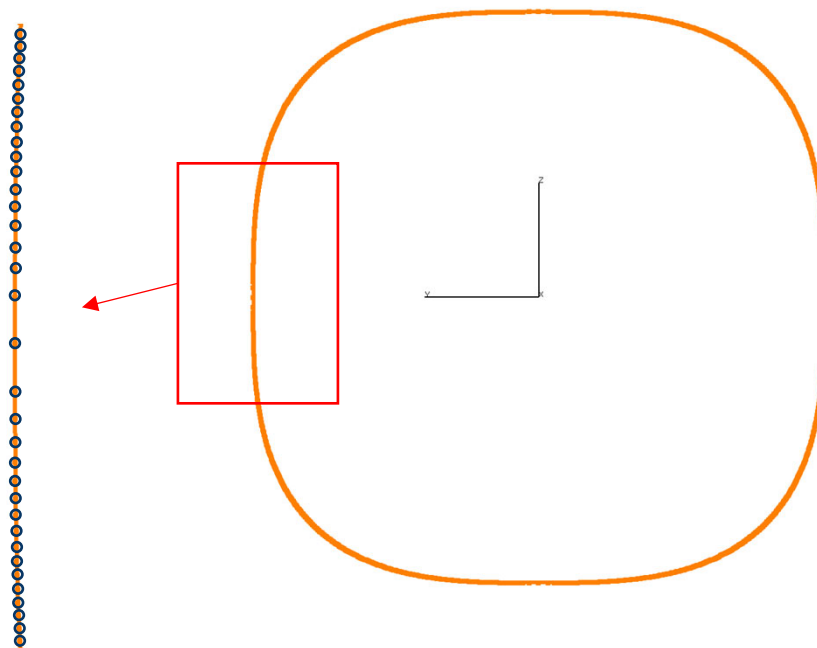

Spacing on Wing Leading Edge

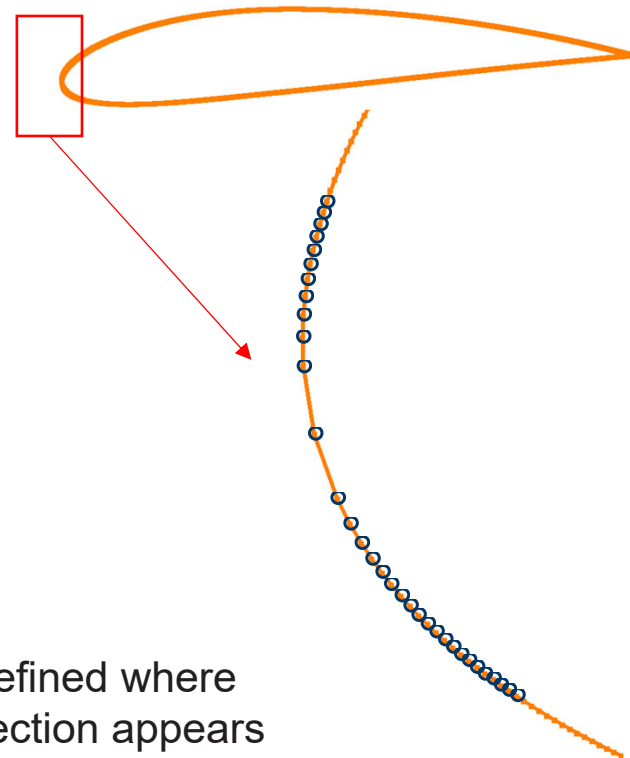

Spacing on lines making up body become less refined where the slope increases. The step taken in the y-direction appears to remain fixed while the spacing the z-direction changes.

## ISSUES

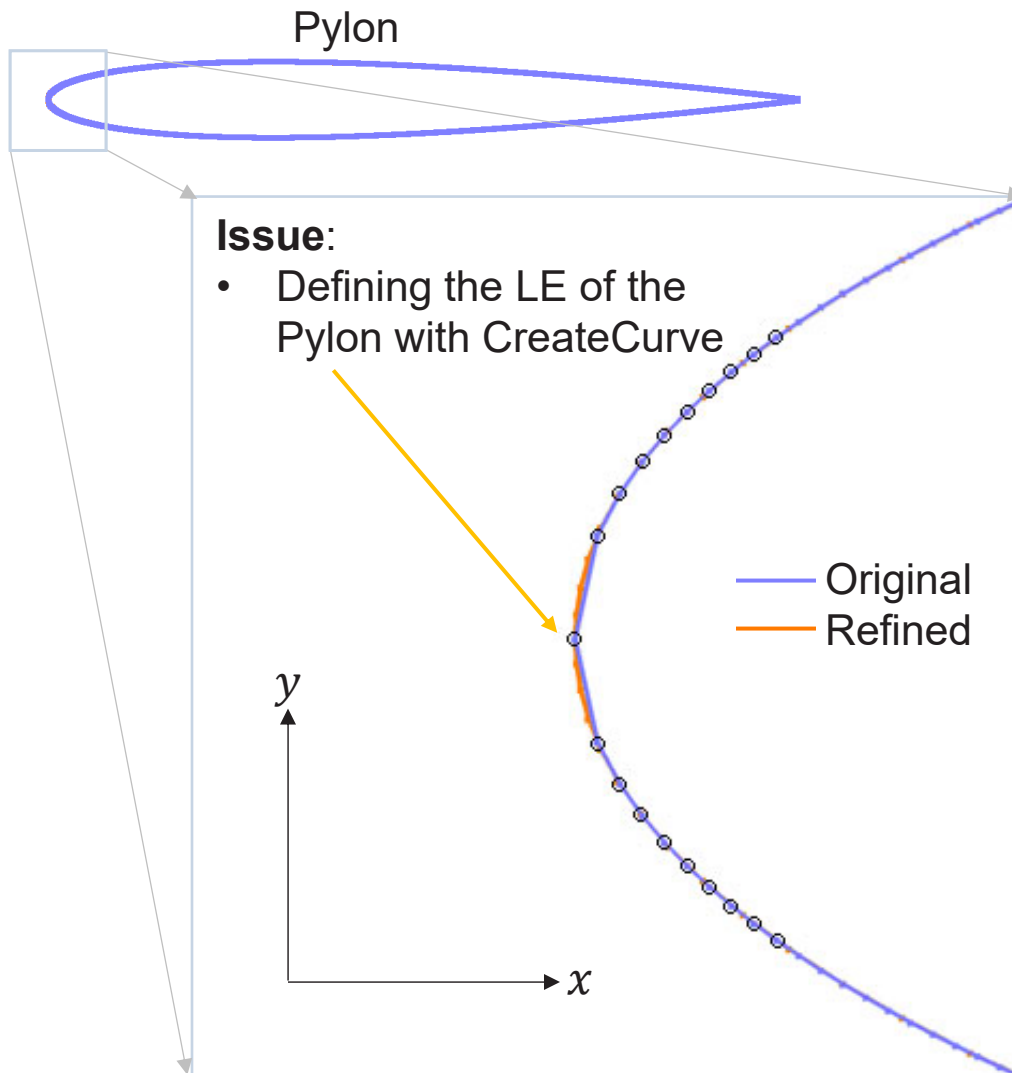
**Solution:**

1. Break CreateCurve into two sections:
  - a.  $0 \leq x \leq 0.025$
  - b.  $0.025 \leq x \leq 1$
2. Concatenate two curves
3. Snap to redistribute points to reasonable spacing

## ISSUES

### Issue:

- Fixed TE spacing constraint
- Surface grid “kinks” in region of TE

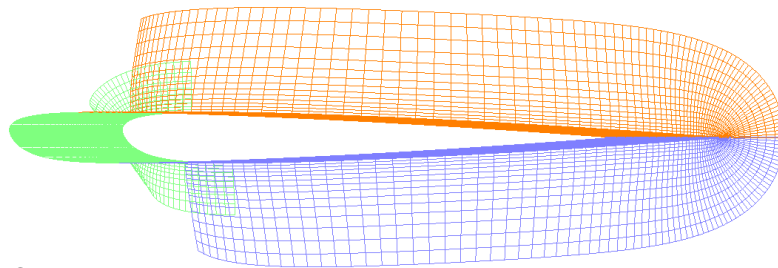

### Solution:

- Consistent spacing transition
- LE and TE collar grids

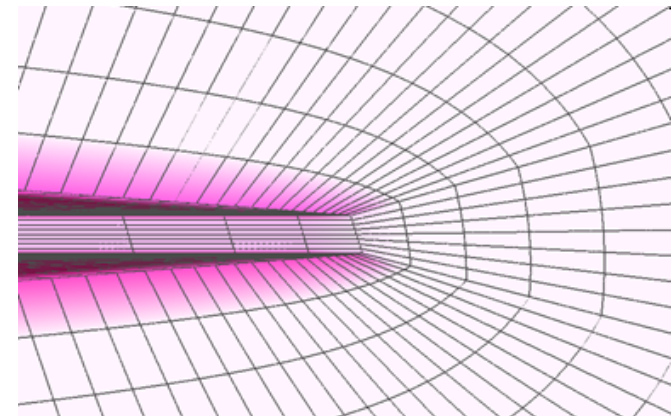
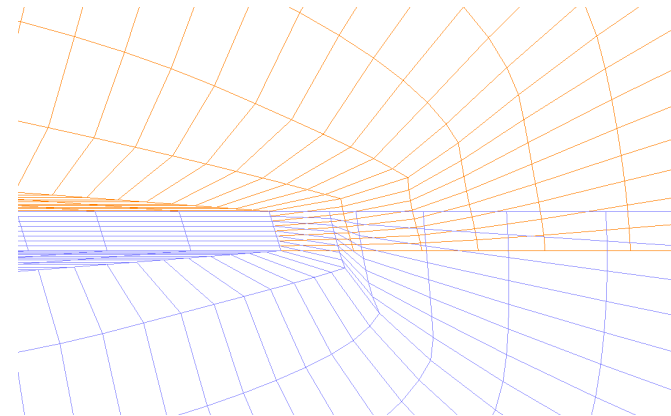
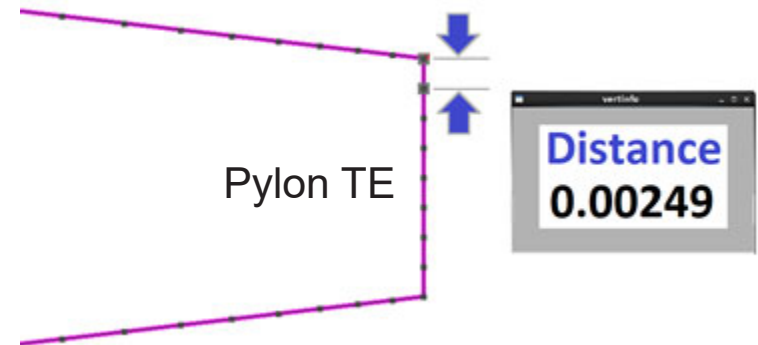
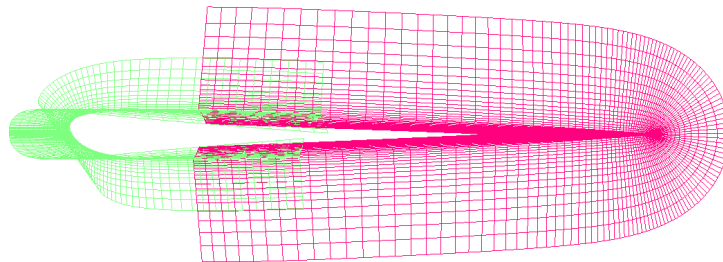

## ISSUES

**Issue:** Spacing transition between Wing ( $\sim 0.5$  ft) to Pylon ( $\sim 0.0025$  ft at TE) grid.

**Solution:** Overset collar grids, and refine Wing spacing in region of the Pod.

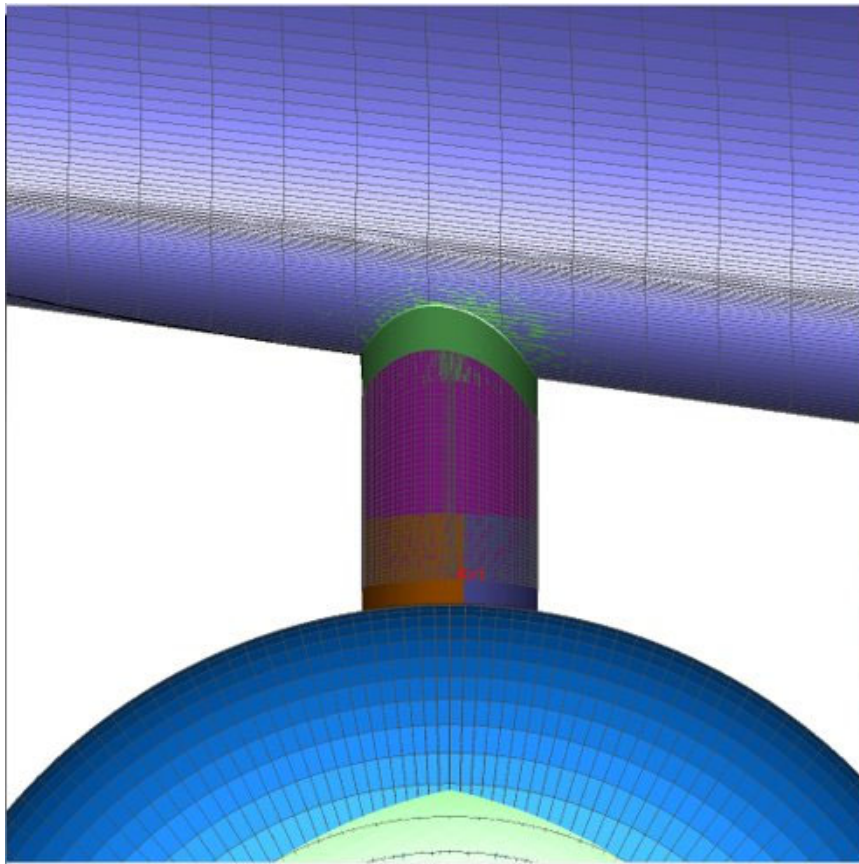

Original

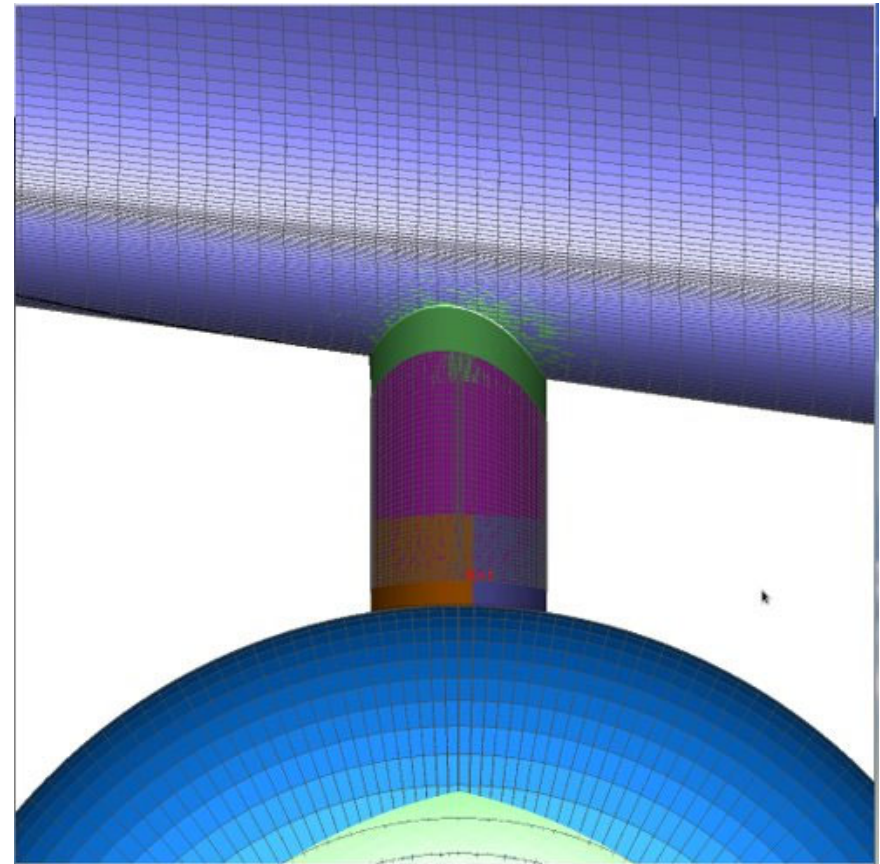

Refined

# FUTURE TOPICS

## FUTURE TOPICS

- “Automatic” structured overset grid generation process
  - CGT developers are working on process to generate surface grids automatically
  - Approach was presented at 2018 Overset Grid Symposium and further development scheduled to be shown at AIAA Aviation 2019 meeting
- Need for parallel grid generation capability for CGT to make use of multi-core desktop workstations
- Tool to sort/orient seam curves in a consistent manner to facilitate the reuse of scripts when dealing with non-analytic, CAD-based design iterations

# CONCLUSIONS / SUMMARY

## CONCLUSIONS / SUMMARY

- Structured overset grids generated for GMGW-2 Case 3 geometry
- Grids were generated using scripts using NASA's Chimera Grid Tools package
- Problem served as a nice benchmark problem for evaluation of grid generation tools/techniques as well as serving as training case for newer users
- Small modifications were required to some scripts due to changes in design variables and/or topology, but most scripts were reusable from design change to design change
- Some issues were encountered with mathematical geometry definitions which should be rectified before GMGW-3 (see backup slides)
- Issues encountered with grid generation approach include
  - Small number of orphans generated with PEGASUS software
  - Difficulty in building collar grids around pylon/pod
  - CGT's "CreateCurve" script using coordinate distances rather than arc length

# QUESTIONS?

# BACK-UP SLIDES

# ISSUES WITH PROBLEM DESCRIPTION

# FUSELAGE

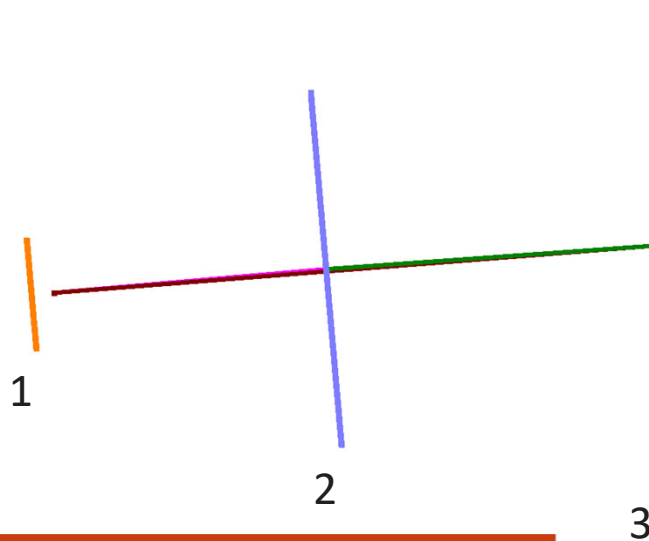
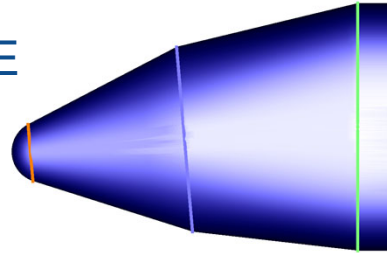

- Section 2 is midway between the nose tip and Section 3, NOT midway between Section 1 and Section 3 as defined.
- The center point of Section 1 is where the tangency occurs, NOT at the center of the sphere.
- With centers of Sections 1 and 2 known, the slope from 1 to 2 was calculated, but one could also have found the slope from 1 to 3 or 2 to 3 since they should lie on the same line according to the definitions but do not actually in the file.
- Radius of Section 2 gets larger in Case 3b with no notification (7.5ft to 8.75ft)

## Fuselage Construction Notes

- Constructed by the fusion of a sphere at the nose and a ruled surface between 5 super-ellipses
  - section 1 is a circle that is tangent to the nose sphere
  - section 2 is a circle whose center is midway between sections 1 and 3 and which is inclined to be perpendicular to the line connecting the centers of section 1 and 3
  - section 3 is a super-ellipse at the forward end of the mid-fuselage, centered at (fwdLength, 0, 0)
  - section 4 is a super-ellipse at the rearward end of the mid-fuselage, centered at (fwdLength+midLength, 0, 0)
  - section 5 is a super-ellipse at the tail, centered at (fwdLength+midLength+aftLength, 0, aftCenter)
- The nose sphere is centered at (noseRad, 0, noseHeight)

# FUSELAGE

## Design Parameters with Baseline Values: Fuselage

```

fuse:noseRad      2.5  # nose radius
fuse:fdwLength    28  # length of forward fuselage
fuse:noseHeight   -2  # zloc of center of nose

fuse:midLength    115  # length of mid fuselage
fuse:midWidth     20  # width of mid fuselage
fuse:midHeight    20  # height of mid fuselage
fuse:power        3    # super-ellipse power of mid and aft fuselage

fuse:aftLength    44  # length of aft fuselage
fuse:aftWidth     1    # width of aft fuselage
fuse:aftHeight    3    # height of aft fuselage
fuse:aftCenter    8.5 # zloc of aft fuselage
    
```

The super-ellipse is defined by

$$y = \pm \text{width} \times \cos^{2/n}(\theta)$$

$$z = \pm \text{height} \times \sin^{2/n}(\theta)$$

for  $0 \leq \theta \leq 2\pi$ .

Note that if  $n = 2$ , the normal circular ellipse results

- The width and height are actually half the of values shown in the text

# HORIZONTAL TAIL

```
# make horizontal tail
IFTHEN makeHtailOml EQ 1
# compute horizontal tail critical locations / dimensions
SET span sqrt(vtail:area*vtail:aspect)
SET chordr 2*vtail:area/span/(1+vtail:taper)
SET chordt chordr*vtail:taper
SET htail_xtip htail:xroot+span*tand(htail:sweep)
SET htail_ytip -span
SET htail_ztip htail:zroot+span*tand(htail:dihedral)

# lay out left horizontal tail
MARK
UDPRIM naca thickness htail:thick sharpTE SHARP_TE
ROTATEX 90 0 0
SCALE chordr
TRANSLATE htail:xroot 0 htail:zroot

UDPRIM naca thickness htail:thick sharpTE SHARP_TE
ROTATEX 90 0 0
SCALE chordt
TRANSLATE htail_xtip htail_ytip htail_ztip
```

htail:area	810	# htail area
htail:aspect	4.15	# htail aspect ratio
htail:taper	0.33	# htail taper ratio
htail:sweep	40	# htail sweep
htail:dihedral	12	# htail dihedral
htail:thick	0.08	# htail thickness
htail:xroot	145	# xloc of root LE
htail:zroot	5	# zloc of root LE
vtail:area	610	# vtail area
vtail:aspect	1.80	# vtail aspect ratio
vtail:taper	0.28	# vtail taper ratio
vtail:sweep	45	# vtail sweep
vtail:thick	0.08	# vtail thickness
vtail:xroot	150	# xloc of root LE
vtail:zroot	9	# zloc of root LE

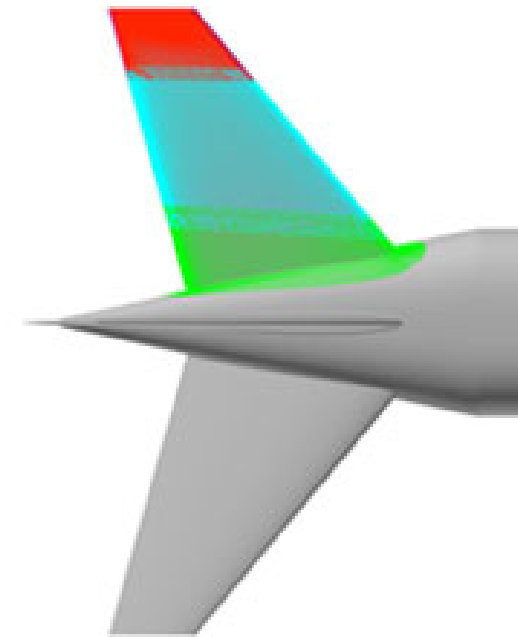

- Vertical Tail values used within the Horizontal Tail definitions
- Span calculation for Vertical Tail is actually semi-span

# ADDITIONAL SURFACE COMPONENT IMAGES

WINGS

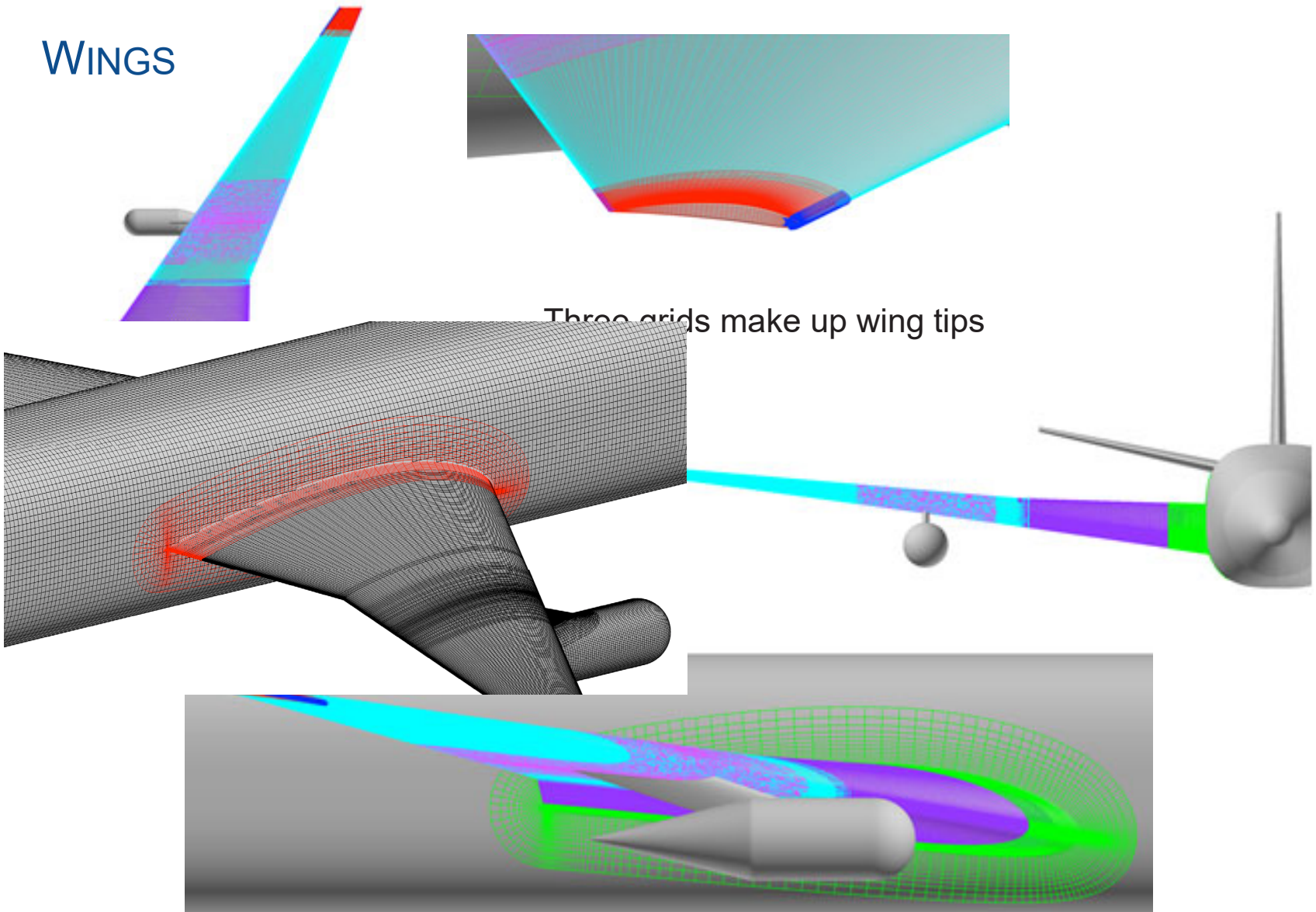

# WINGS

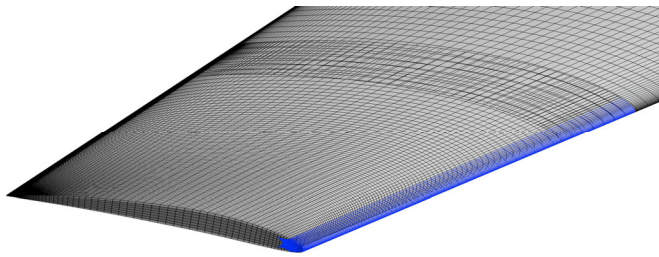

Leading Edge

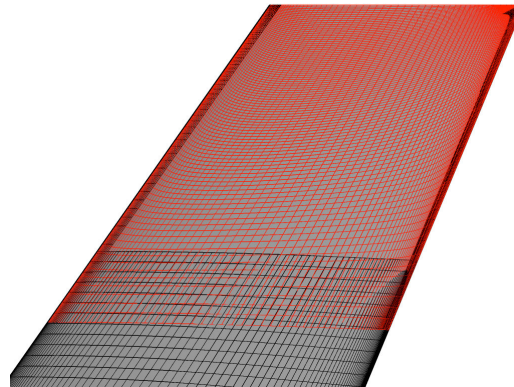

Wing Tip C-grid

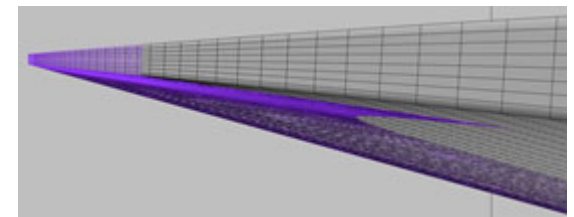
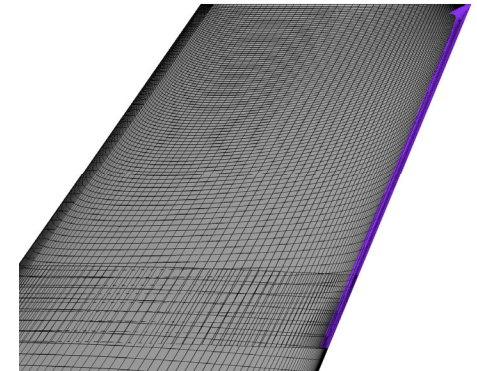

Trailing Edge

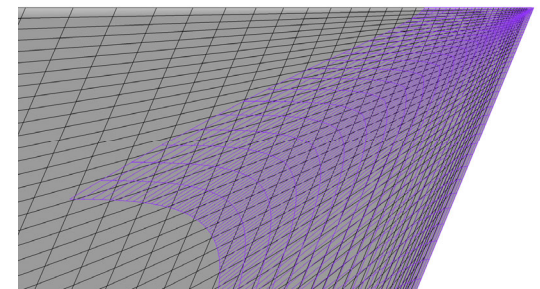
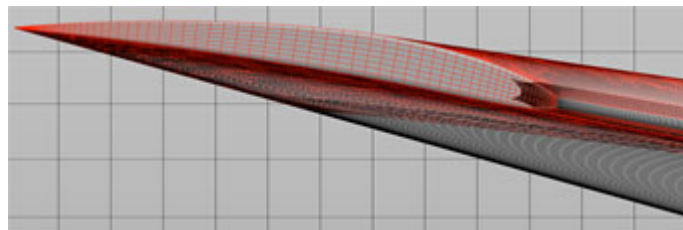
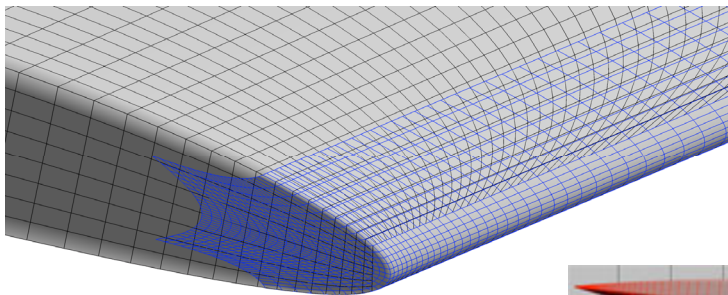

## WING TIP

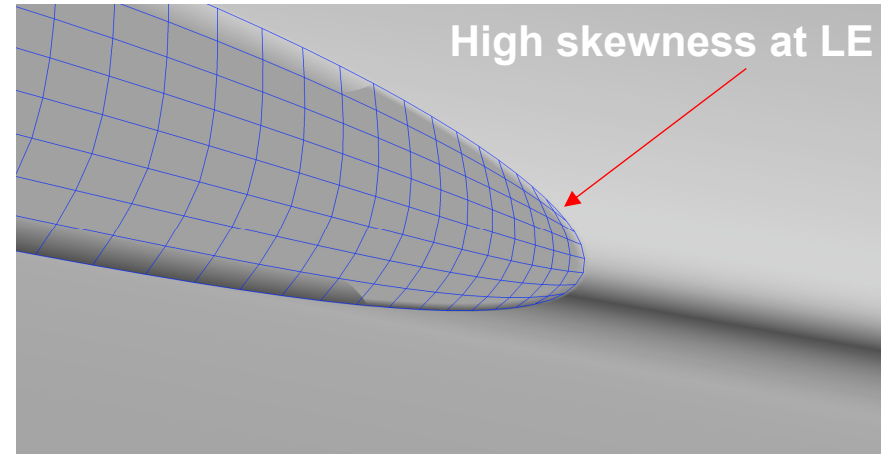
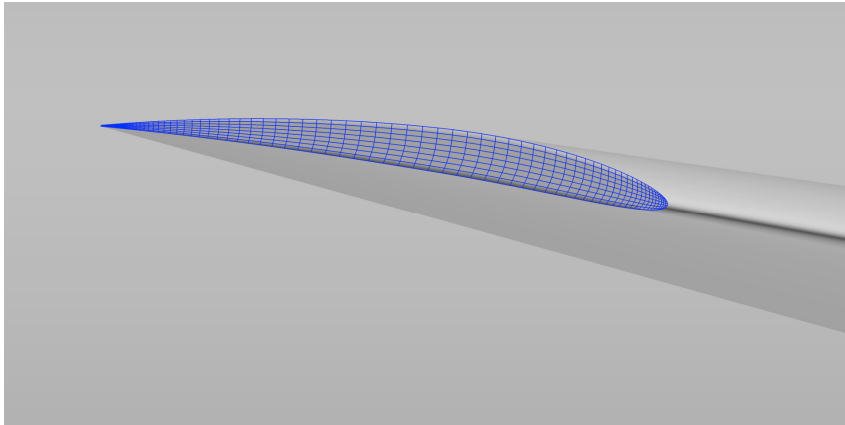

- Can use this grid as a cap for a cap/collar but collar will likely have highly skewed elements as well near corners
- Can also be used in combination with attached LE and TE grids and then grown on the upper and lower surfaces to form a single grid covering the wing tip similar to below
- Growing onto surface tends to follow curvature of that surface, creating a grid that pulls away from the LE (blue)

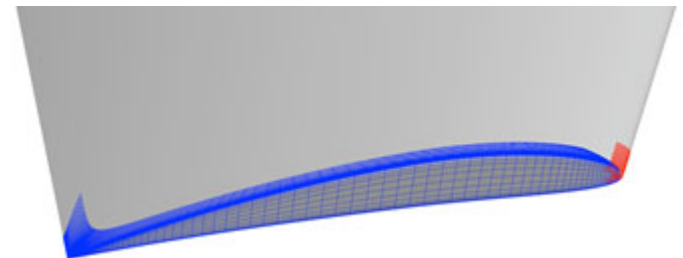
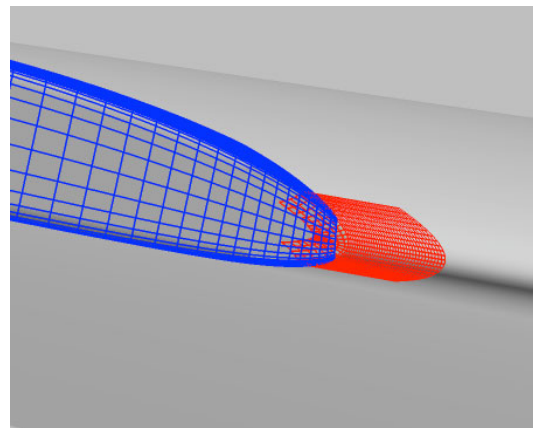
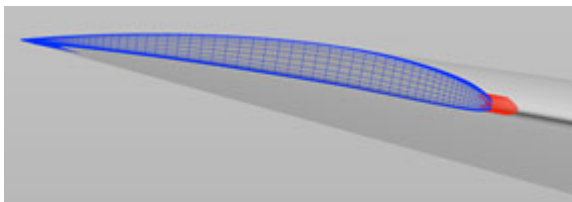

## WING/FUSELAGE COLLAR

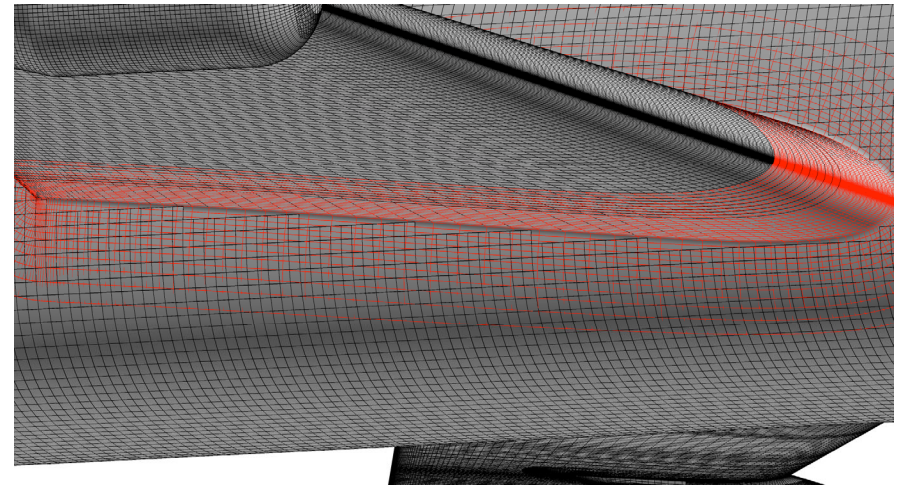
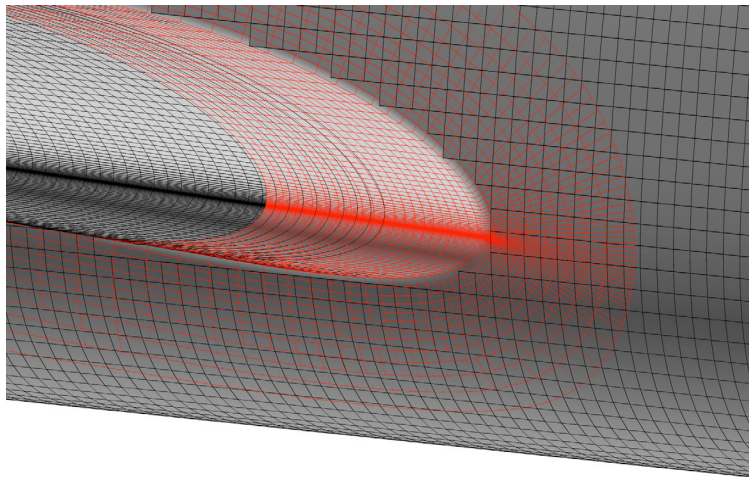
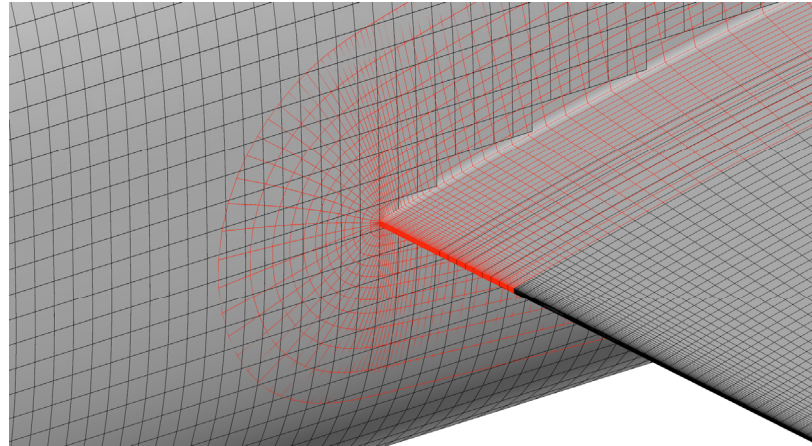

# HORIZONTAL TAILS

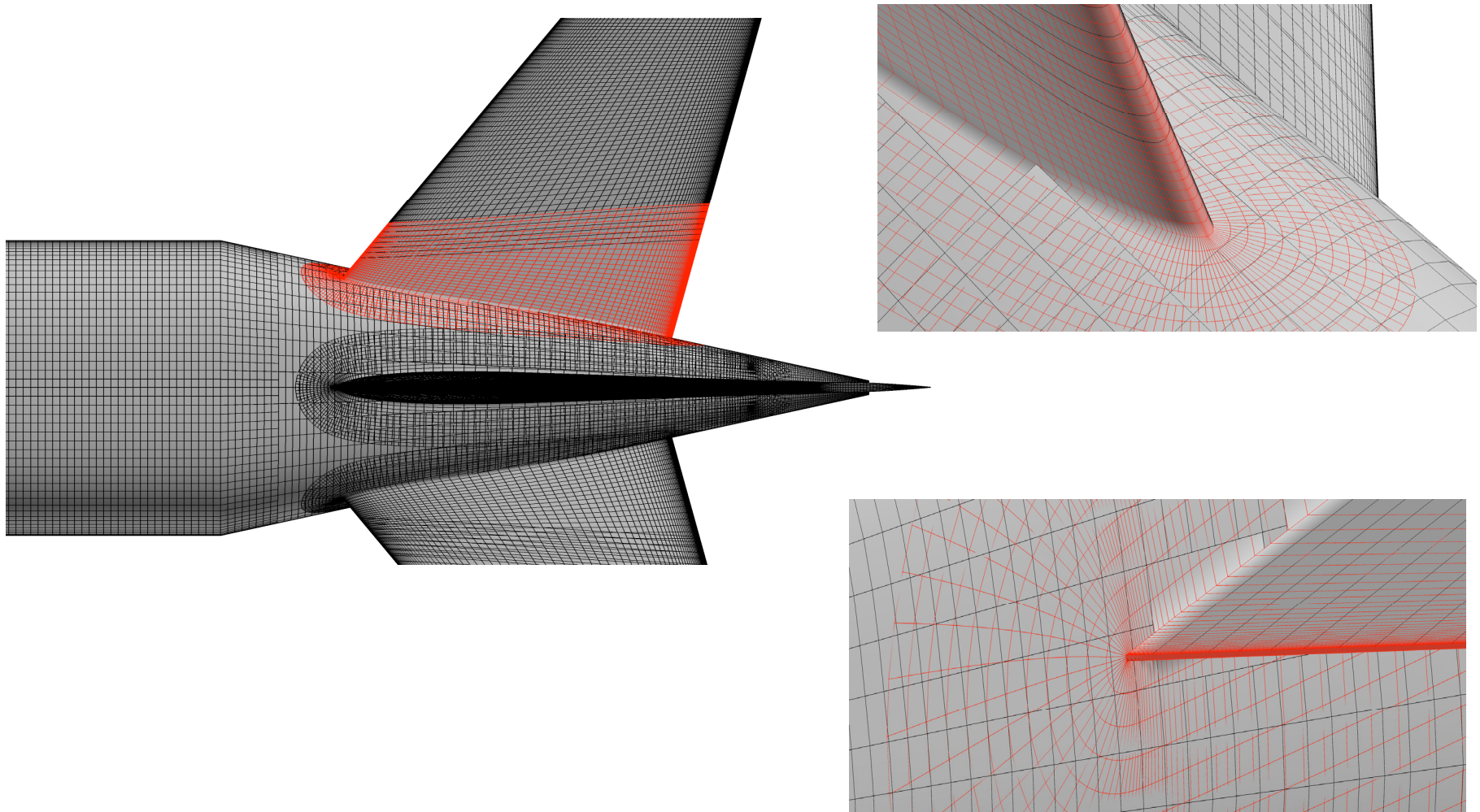

# VERTICAL TAIL

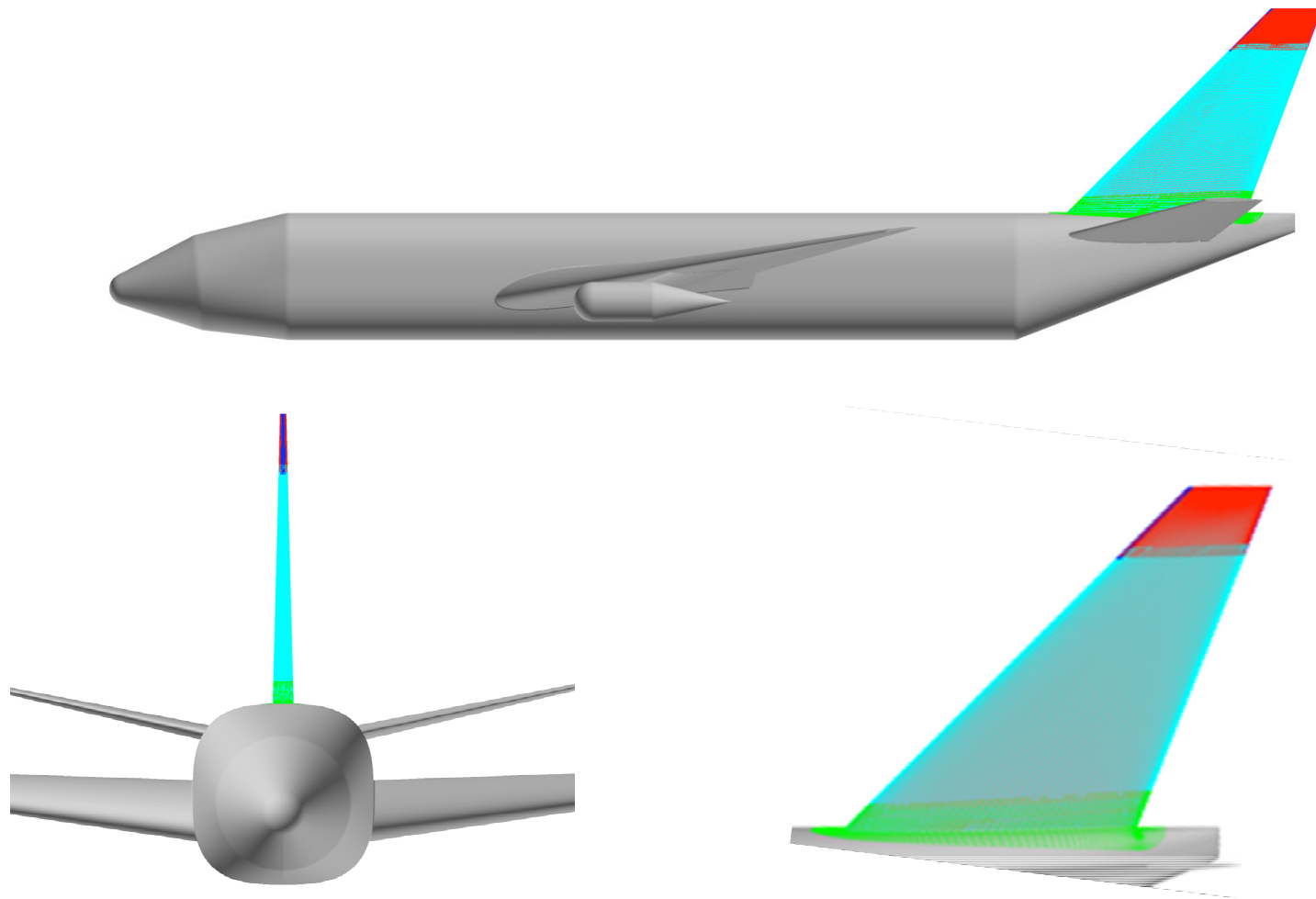

## VERTICAL TAIL

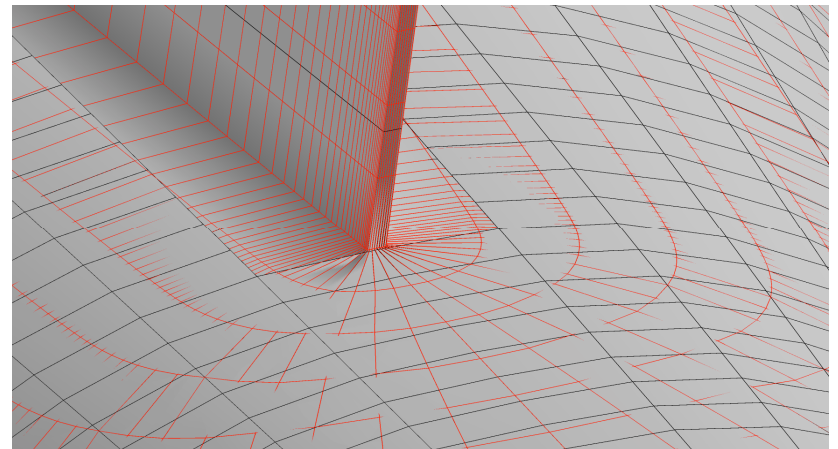
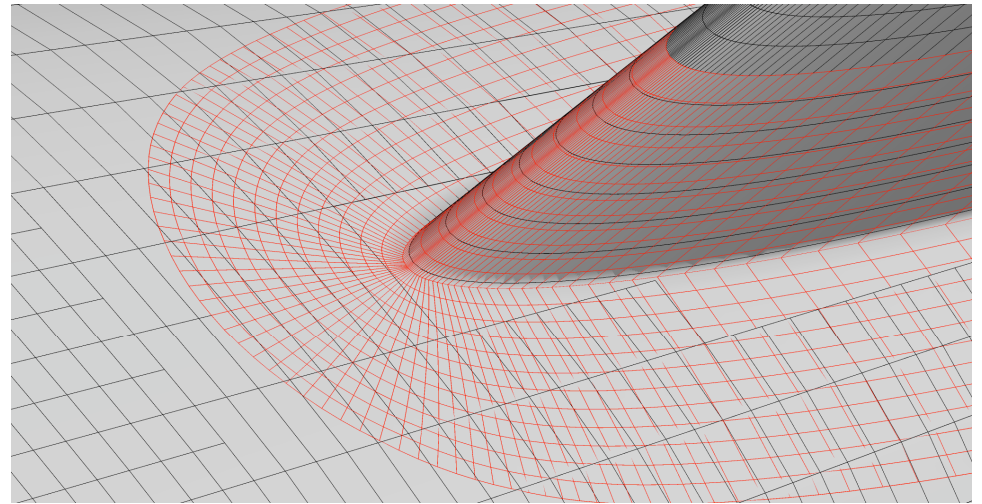
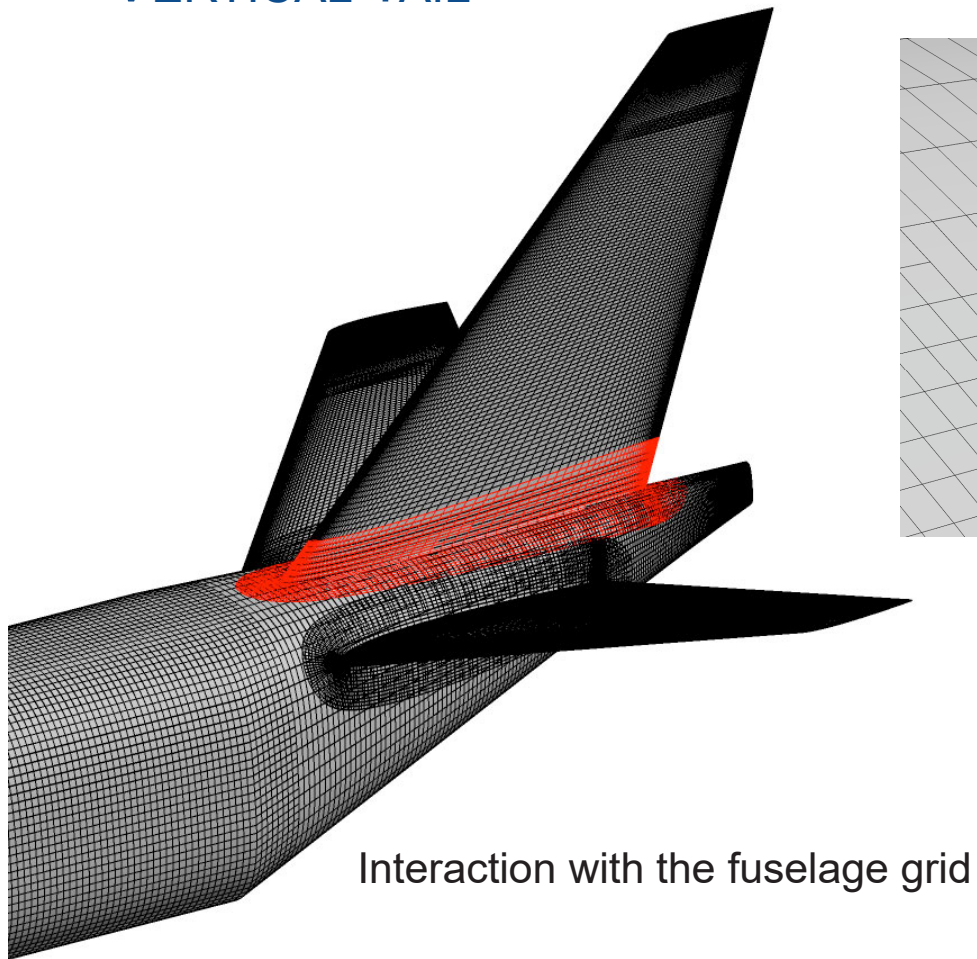

Interaction with the fuselage grid